

**3GPP TSG-RAN WG2
Berlin, 25th to 28th May 99**

TSGR2#4(99)354

Agenda Item: 4.2 (Permanent documents)

Source: Editor

Title: 25.302, Services provided by the Physical Layer, V2.0.1

Document for: Approval

Summary of modifications :

This document was updated with the new 3GPP template.
Some changes were made following comments received from the editor of S1.01, related to evolutions in WG1, and also some editorial modifications.

**3rd Generation Partnership Project (3GPP);
Technical Specification Group (TSG) RAN;
Working Group 2 (WG2);**

Services provided by the Physical Layer



The present document has been developed within the 3rd Generation Partnership Project (3GPP™) and may be further elaborated for the purposes of 3GPP.

The present document has not been subject to any approval process by the 3GPP Organisational Partners and shall not be implemented.

This Specification is provided for future development work within 3GPP only. The Organisational Partners accept no liability for any use of this Specification.

Specifications and reports for implementation of the 3GPP™ system should be obtained via the 3GPP Organisational Partners' Publications Offices.

Reference

<Workitem> (<Shortfilename>.PDF)

Keywords

Digital cellular telecommunications system,
Universal Mobile Telecommunication System
(UMTS), UTRA, IMT-2000

3GPP

Postal address

Office address

Internet

secretariat@3gpp.org
Individual copies of this deliverable
can be downloaded from
<http://www.3gpp.org>

Copyright Notification

No part may be reproduced except as authorized by written permission.
The copyright and the foregoing restriction extend to reproduction in all media.

©
All rights reserved.

Contents

1	Scope	5
2	References	5
3	Definitions and Abbreviations	5
3.1	Definitions	5
3.2	Abbreviations	6
4	Interfaces to the physical layer	8
4.1	Interface to MAC	8
4.2	Interface to RRC	8
5	Services and functions of the physical layer	9
5.1	General	9
5.2	Overview of L1 functions	9
5.3	L1 interactions with L2 retransmission functionality	9
6	Model of physical layer of the UE	10
6.1	Uplink models	10
6.2	Downlink models	11
6.3	Relay link Model	12
7	Formats and configurations for L1 data transfer	12
7.1	General concepts about Transport Channels	12
7.1.1	Transport Block	13
7.1.2	Transport Block Size	13
7.1.3	Transport Block Set Size	13
7.1.4	Transmission Time Interval	13
7.1.5	Transport Format	14
7.1.6	Transport Format Set	14
7.1.7	Transport Format Combination	14
7.1.8	Transport Format Combination Set	15
7.1.9	Transport Format Indicator (TFI)	15
7.1.10	Transport Format Combination Indicator (TFCI)	16
7.2	Types of Transport Channels	16
7.3	Slotted Mode	18
8	Primitives of the physical layer	19
8.1	Generic names of primitives between layers 1 and 2	19
8.1.1	MPHY-CONNECT	19
8.1.2	MPHY-DISCONNECT	19
8.1.3	MPHY-DATA	19
8.1.4	MPHY-STATUS	20
8.2	Generic names of primitives between layers 1 and 3	20
8.2.1	STATUS PRIMITIVES	20
8.2.2	CONTROL PRIMITIVES	21
8.3	Parameter definition	22
8.3.1	Received transmission quality parameters	22
8.3.2	Radio link to be reported	22

8.3.3	Error code	22
8.3.4	Physical channel description	22
8.3.5	Action	22
9	Radio Frame transmission	22
9.1	Downlink Frame format	22
9.2	Uplink Frame format	22
9.3	Order of bit transmission	22
10	History	24

Intellectual Property Rights

Foreword

This Technical Specification has been produced by the 3GPP.

The contents of the present document are subject to continuing work within the TSG and may change following formal TSG approval. Should the TSG modify the contents of this TS, it will be re-released by the TSG with an identifying change of release date and an increase in version number as follows:

Version 3.y.z

where:

- x the first digit:
 - 1 presented to TSG for information;
 - 2 presented to TSG for approval;
 - 3 Indicates TSG approved document under change control.
- y the second digit is incremented for all changes of substance, i.e. technical enhancements, corrections, updates, etc.
- z the third digit is incremented when editorial only changes have been incorporated in the specification;

1 Scope

The present document is a technical specification of the services provided by the physical layer of UTRA to upper layers.

2 References

References may be made to:

- a) specific versions of publications (identified by date of publication, edition number, version number, etc.), in which case, subsequent revisions to the referenced document do not apply;
- b) all versions up to and including the identified version (identified by "up to and including" before the version identity);
- c) all versions subsequent to and including the identified version (identified by "onwards" following the version identity); or
- d) publications without mention of a specific version, in which case the latest version applies.

A non-specific reference to an ETS shall also be taken to refer to later versions published as an EN with the same number.

- [1] ETSI UMTS 23.10 : UMTS Access Stratum Services and Functions
- [2] 3GPP [TS 25.301](#) ~~RAN S2.01~~ : Radio Interface Protocol Architecture
- [3] [3GPP TS 25.212](#) ~~ETSI UMTS XX.04~~: UTRA FDD multiplexing, channel coding and interleaving description
- [4] [3GPP TS 25.222](#) ~~ETSI UMTS XX.10~~: UTRA TDD multiplexing, channel coding and interleaving description

3 Definitions and Abbreviations

3.1 Definitions

See [3] for a definition of fundamental concepts and vocabulary.

3.2 Abbreviations

ARQ	Automatic Repeat Request
BCCCH	Broadcast Control Channel
BCH	Broadcast Channel
C-	Control-
CC	Call Control
CCCH	Common Control Channel
CCH	Control Channel
CCTrCH	Coded Composite Transport Channel
CN	Core Network
CRC	Cyclic Redundancy Check
DC	Dedicated Control (SAP)
DCA	Dynamic Channel Allocation
DCCH	Dedicated Control Channel
DCH	Dedicated Channel
DL	Downlink
DRNC	Drift Radio Network Controller
DSCH	Downlink Shared Channel
DTCH	Dedicated Traffic Channel
FACH	Forward Link Access Channel
FAUSCH	Fast Uplink Signalling Channel
FCS	Frame Check Sequence
FDD	Frequency Division Duplex
GC	General Control (SAP)
HO	Handover
ITU	International Telecommunication Union
kbps	kilo-bits per second
L1	Layer 1 (physical layer)
L2	Layer 2 (data link layer)
L3	Layer 3 (network layer)
LAC	Link Access Control
LAI	Location Area Identity
MAC	Medium Access Control
MM	Mobility Management
Nt	Notification (SAP)
OCCCH	ODMA Common Control Channel
ODCCH	ODMA Dedicated Control Channel
ODCH	ODMA Dedicated Channel
ODMA	Opportunity Driven Multiple Access
ORACH	ODMA Random Access Channel
ODTCH	ODMA Dedicated Traffic Channel
PCCH	Paging Control Channel
PCH	Paging Channel
PDU	Protocol Data Unit
PHY	Physical layer
PhyCH	Physical Channels
RACH	Random Access Channel
RLC	Radio Link Control
RNC	Radio Network Controller
RNS	Radio Network Subsystem
RNTI	Radio Network Temporary Identity
RRC	Radio Resource Control
SAP	Service Access Point
SCCH	Synchronization Control Channel
SCH	Synchronization Channel
SDU	Service Data Unit
SRNC	Serving Radio Network Controller
SRNS	Serving Radio Network Subsystem
TCH	Traffic Channel

TDD	Time Division Duplex
TFCI	Transport Format Combination Indicator
TFI	Transport Format Indicator
TMSI	Temporary Mobile Subscriber Identity
TPC	Transmit Power Control
U-	User-
UE	User Equipment
UE _R	User Equipment with ODMA relay operation enabled
UL	Uplink
UMTS	Universal Mobile Telecommunications System
URA	UTRAN Registration Area
UTRA	UMTS Terrestrial Radio Access
UTRAN	UMTS Terrestrial Radio Access Network

4 Interfaces to the physical layer

The physical layer (layer 1) is the lowest layer in the OSI Reference Model and it supports all functions required for the transmission of bit streams on the physical medium.

The physical layer interfaces the Medium Access Control (MAC) Layer and the Radio Resource Control (RRC) Layer as depicted in figure 2.1.

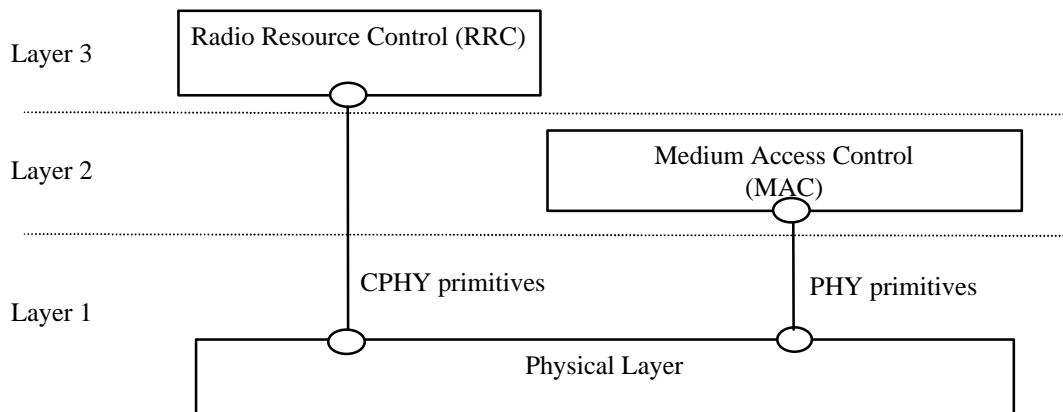

Figure 1 : Interfaces with the Physical Layer

4.1 Interface to MAC

The physical layer interfaces the MAC entity of layer 2.. Communication between the Physical Layer and MAC is in an abstract way performed by means of PHY-primitives defined which do not constrain implementations.

NOTE: The terms physical layer and layer 1, will be used synonymously in this description.

The PHY-primitives exchanged between the physical layer and the data link layer provide the following functions:

- transfer of transport blocks over the radio interface
- indicate the status of the layer 1 to layer 2

4.2 Interface to RRC

The physical layer interfaces the RRC entity of layer 3 in the UE and in the network.

Communication is performed in an abstract way by means of CPHYMPH-primitives. They do not constrain implementations.

The CPHYMPH-primitives exchanged between the physical layer and the Network layer provide the following function:

- control of the configuration of the physical layer

The currently identified exchange of information across that interface have only a local significance to the UE or Network.

5 Services and functions of the physical layer

5.1 General

The physical layer offers data transport services to higher layers. The access to these services is through the use of transport channels via the MAC sub-layer. The characteristics of a transport channel are defined by its transport format (or format set), specifying the physical layer processing to be applied to the transport channel in question, such as ~~outer coding and interleaving (if any), and~~ inner channel coding and interleaving, and any service-specific rate matching as needed.

The physical layer operates exactly according to the L1 radio frame timing. A transport block is defined as the data accepted by the physical layer to be jointly encoded. The transmission block timing is then tied exactly to this L1 frame timing, e.g. every transmission block is generated precisely every 10ms, or a multiple of 10 ms.

A UE can set up multiple transport channels simultaneously, each having own transport characteristics (e.g. offering different error correction capability). Each transport channel can be used for information stream transfer of one radio bearer or for layer 2 and higher layer signalling messages.

The multiplexing of these transport channels onto the same or different physical channels is carried out by L1. In addition, the Transport Format Combination Indication field (TFCI) shall uniquely identify the transport format used by each transport channel of the Coded Composite Transport Channel within the current radio frame.

5.2 Overview of L1 functions

The physical layer performs the following main functions:

- FEC encoding/decoding of transport channels
- Measurements and indication to higher layers (e.g. FER, SIR, interference power, transmission power, etc...)
- Macrodiversity distribution/combining and soft handover execution
- Error detection on transport channels
- Multiplexing of transport channels and demultiplexing of coded composite transport channels
- Rate matching
- Mapping of coded composite transport channels on physical channels
- Modulation and spreading/demodulation and despreading of physical channels
- Frequency and time (chip, bit, slot, frame) synchronization
- Closed-loop power control
- Power weighting and combining of physical channels
- RF processing

5.3 L1 interactions with L2 retransmission functionality

Provided that the RLC PDUs are mapped one-to-one onto the Transport Blocks, Error indication may be provided by L1 to L2. For that purpose, the L1 CRC can be used for individual error indication of each RLC PDU. The L1 CRC will then serve multiple purposes:

- Error indication for uplink macro diversity selection combining (L1)
- Frame error indication for speech services
- Quality indication
- Error indication for L2 retransmissions

~~For Transport Channels using outer coding (RS coding) information from the RS decoder may be used for error indication for the purpose of L2 re-transmissions.~~

As a conclusion, L1 needs to give an error indication to L2 for each erroneous Transport Block delivered.

6 Model of physical layer of the UE

6.1 Uplink models

Figure 2 shows models of the UE's physical layer in the uplink for both FDD and TDD mode. It shows two models: DCH model and RACH model. Only one type of transport channel is used at a time by one UE. Hence, both models are not in use simultaneously within one UE. More details can be found in [3] and [4].

Editors note: Models for uplink transport channels currently marked ffs will be necessary if these channels are included in the description.

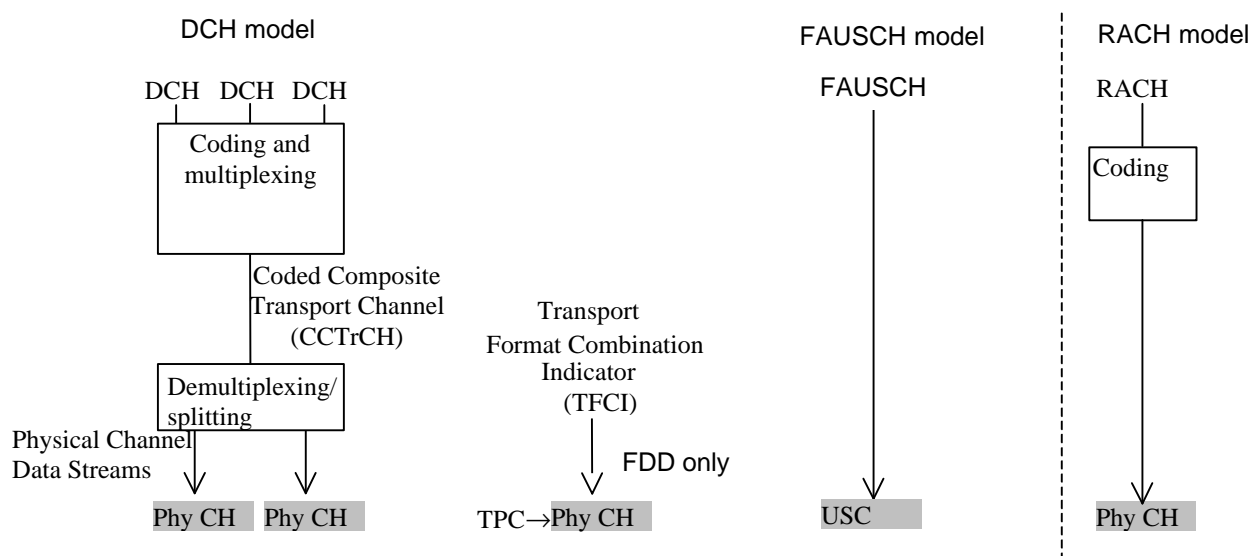

Figure 2: Model of the UE's physical layer – uplink

The DCH model shows that one or several DCHs can be processed and multiplexed together by the same coding and multiplexing unit. The detailed functions of the coding and multiplexing unit are not defined in this document but in [XX.04 \[1\] \[3\]](#) and [XX.10 \[2\] \[4\]](#). The single output data stream from the coding and multiplexing unit is denoted *Coded Composite Transport Channel (CCTrCH)*.

The data stream of the CCTrCH is fed to a data demultiplexing/splitting unit that demultiplexes/splits the CCTrCH's data stream onto one or several *Physical Channel Data Streams*.

Editors's note: The term "splitting" used for above function in FDD mode has been replaced by "demultiplexing/splitting". The intention of using the term splitting is to express that this function is performed on bit level not on some block level. The term demultiplexing/splitting shall cover both cases, block or bit level demultiplexing, where block lengths larger than 1 bit may be applied in the TDD mode. This needs to be confirmed by the L1 group

The current configuration of the coding and multiplexing unit is either signalled to, or optionally blindly detected by, the network for each 10 ms frame. If the configuration is signalled, it is represented by the *Transport Format Combination Indicator (TFCI)* bits. Note that the TFCI signalling only consists of pointing out the current transport format combination within the already configured transport format combination set. In the uplink there is only one TFCI representing the current transport formats on all DCHs of one CCTrCH simultaneously. In FDD mode, the physical channel data stream carrying the TFCI is mapped onto the physical channel carrying the power control bits and the pilot.

For the FAUSCH, there is no coding, since the FAUSCH is only used for the transmission of a reservation request by sending an up-link signalling code (USC) at the time-offset allocated for the specific UE during the 10 ms frame. Due to the fixed time-offset allotted to a specific UE, the FAUSCH is a dedicated control channel.

The model for the RACH case shows that RACH is the only common type transport channel in the uplink. RACHs are always mapped one-to-one onto physical channels, i.e. there is no physical layer multiplexing of RACH. Service multiplexing is handled by the MAC layer.

6.2 Downlink models

Figure 3 and Figure 4 show the model of the UE's physical layer for the downlink in FDD and TDD mode, respectively. Note that there is a different model for each transport channel type.

Editors note: Models for downlink transport channels currently marked ffs will be necessary if these channels are included in the description.

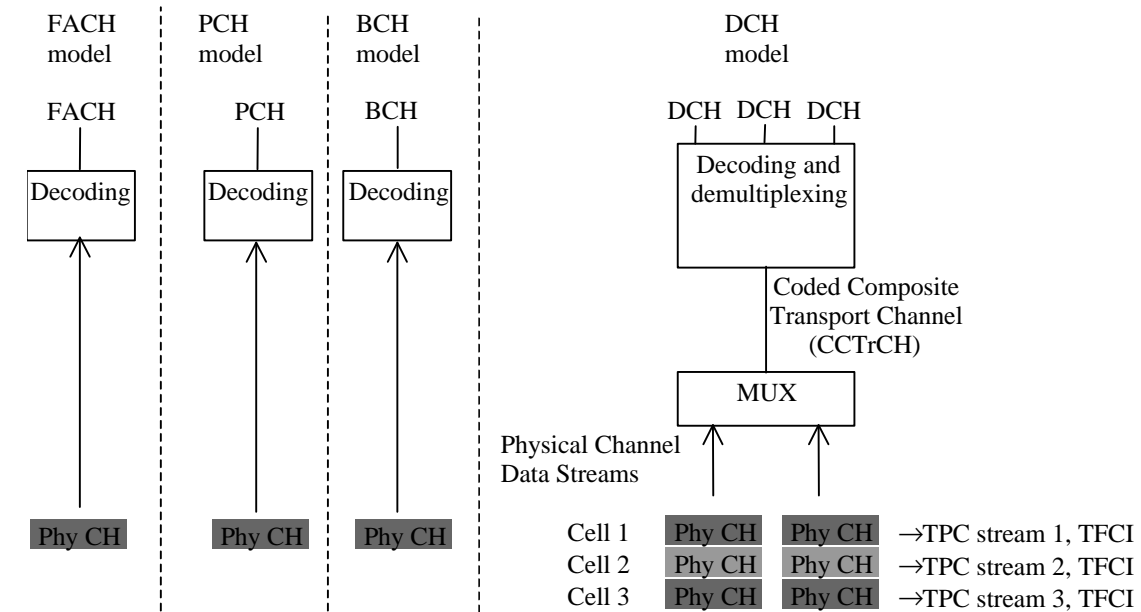

Figure 3: Model of the UE's physical layer – downlink FDD mode

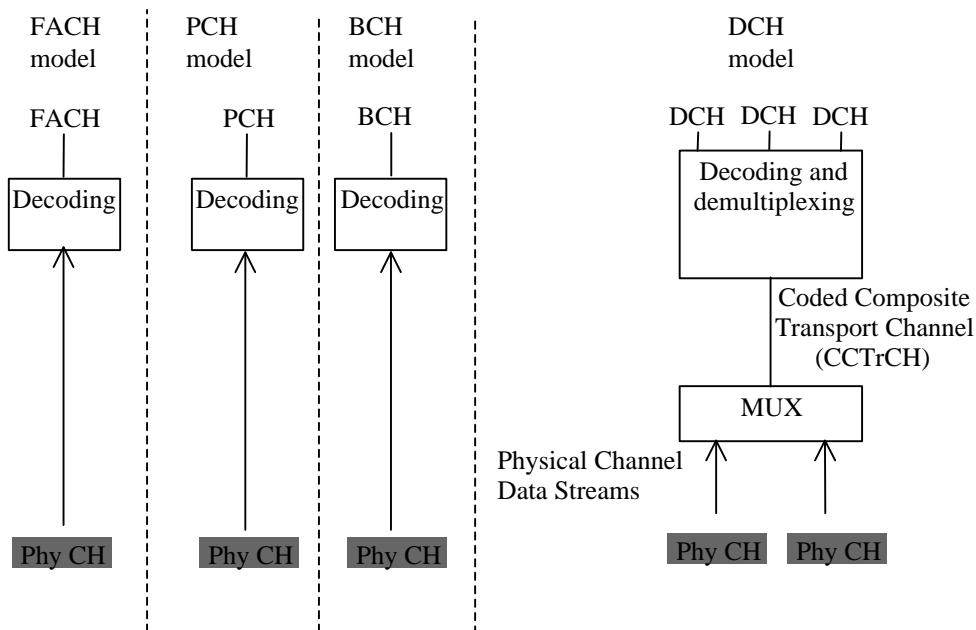

Figure 4: Model of the UE's physical layer – downlink TDD mode

For the DCH case, the mapping between DCHs and physical channel data streams works in the same way as for the uplink. Note however, that the number of DCHs, the coding and multiplexing etc. may be different in uplink and downlink.

In the FDD mode, the differences are mainly due to the soft and softer handover. Further, the pilot, TPC bits and TFCI are time multiplexed onto the same physical channel(s) as the DCHs. Further, the definition of physical channel data stream is somewhat different from the uplink.

Note that it is logically one and the same physical data stream in the active set of cells, even though physically there is one stream for each cell. The same processing and multiplexing is done in each cell. The only difference between the cells is the actual codes, and these codes correspond to the same spreading factor.

The physical channels carrying the same physical channel data stream are combined in the UE receiver, excluding the pilot, and in some cases the TPC bits. TPC bits received on certain physical channels may be combined provided that UTRAN has informed the UE that the TPC information on these channels is identical.

The downlink models for the BCH, PCH and FACH show that BCH, PCH and FACH are always mapped one-to-one onto physical channels, i.e. there is no physical layer multiplexing of BCH, PCH and FACH. Service multiplexing is handled by the MAC layer. Note, in the TDD mode there is the SCH in addition (not shown in Figure 4).

6.3 Relay link Model

The Relay link applies to the TDD mode only. The applicability to the FDD mode is FFS.

Figure 4 illustrates the model of the UE's physical layer for the TDD mode.

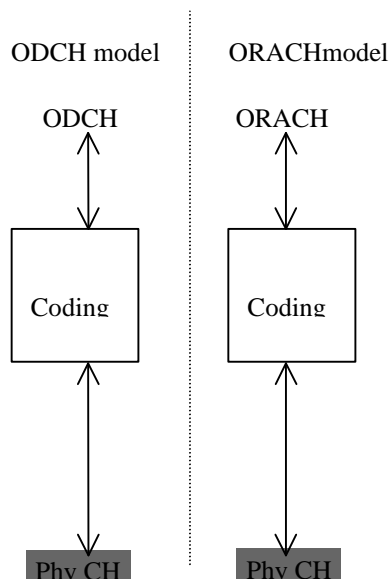

Figure 5 : Model of the UE's physical layer - relay link TDD mode.

The ORACH is a channel used within UE's to transmit and receive probing messages, and also to transmit and receive small packets of information. The ODCH is used to transmit larger amounts of data over a number of hops between UE's.

7 Formats and configurations for L1 data transfer

7.1 General concepts about Transport Channels

Layer 2 is responsible for the mapping of data onto L1 via the L1/L2 interface that is formed by the transport channels. In order to describe how the mapping is performed and how it is controlled, some definitions and terms are required.

The required definitions are given in the following sections. Note that the definitions are generic for all transport channel types, i.e. not only for DCHs.

All Transport Channels are defined as unidirectional (i.e. uplink, downlink, or relay-link). This means that a UE can have simultaneously (depending on the services and the state of the UE) one or several transport channels in the downlink, and one or more Transport Channel in the uplink.

7.1.1 Transport Block

This is the basic unit exchanged between L1 and MAC, for L1 processing.

A Transport Block typically corresponds to an RLC PDU or corresponding unit. In the TDD mode it may possibly also be formed by a MAC peer-to-peer message. Layer 1 adds a CRC for each Transport Block.

Transport Block Set This is defined as a set of Transport Blocks which are exchanged between L1 and MAC at the same time instance using the same transport channel.

7.1.2 Transport Block Size

This is defined as the number of bits in a Transport Block.

7.1.3 Transport Block Set Size

This is defined as the number of bits in a Transport Block Set.

7.1.4 Transmission Time Interval

This is defined as the inter-arrival time of Transport Block Sets, i.e. the periodicity at which a Transport Block Set is transferred by the physical layer. It is always a multiple of the minimum interleaving period (e.g. 10ms, the length of one Radio Frame).

Figure 6 shows an example where Transport Block Sets, at certain time instances, are exchanged between MAC and L1 via three parallel transport channels. Each Transport Block Set consists of a number of Transport Blocks. The Transmission Time Interval, i.e. the time between consecutive deliveries of data between MAC and L1, is also illustrated. Last, the case when the last Transport Block is smaller than the allowed size is shown, with the topmost Transport Block being partially empty.

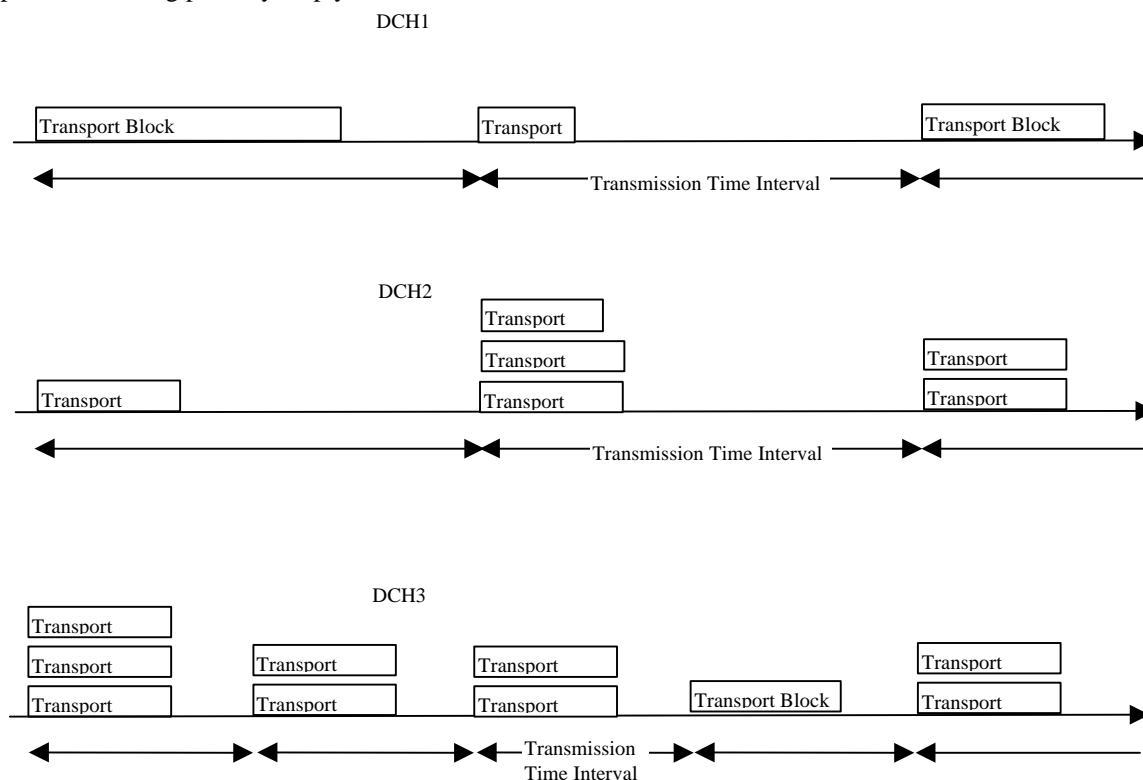

Figure 6. Exchange of data between MAC and L1

7.1.5 Transport Format

This is defined as a format offered by L1 to MAC (and vice versa) for the delivery of a Transport Block Set during a Transmission Time Interval on a Transport Channel. The Transport Format constitutes of two parts – one *dynamic* part and one *semi-static* part.

Attributes of the dynamic part are:

- Transport Block Size
- Transport Block Set Size
- Transmission Time Interval (option for TDD only)

Attributes of the semi-static part are:

- Transmission Time Interval (mandatory for FDD, optional for the dynamic part of TDD NRT bearers)
- Type of channel coding
 - Outer coding (e.g. Reed Solomon)
 - Outer interleaving (depth of the outer interleaving in radio frames)
 - Inner coding
 - Inner interleaving (depth of the inner interleaving in radio frames)
- Rate matching

In the following example, the Transmission time Interval is seen as a semi-static part

Example:

- Dynamic part: {320 bits, 640 bits}, Semi-static part: {10ms, Inner coding only, repeat 1/12 of the bits}

7.1.6 Transport Format Set

This is defined as the set of Transport Formats associated to a Transport Channel.

The semi-static parts of all Transport Formats are the same within a Transport Format Set.

Effectively the first two attributes of the dynamic part form the instantaneous bit rate on the Transport Channel. Variable bit rate on a Transport Channel may, depending on the type of service which is mapped onto the transport channel, be achieved by changing between each Transmission Time Interval one of the following:

1. the Transport Block Size only
2. the Transport Block Set Size only
3. both the Transport Block Size and the Transport Block Set Size

Example 1:

- Dynamic part: {20 bits, 20 bits}; {40 bits, 40 bits}; {80 bits, 80 bits}; {160 bits, 160 bits}
- Semi-static part: {10ms, Inner coding only, repeat 1/12 of the bits}

Example 2:

- Dynamic part: {320 bits, 320 bits}; {320 bits, 640 bits}; {320 bits, 1280 bits}
- Semi-static part: {10ms, Inner coding only, repeat 1/12 of the bits}

The first example may correspond to a Transport Channel carrying a speech service, requiring blocks delivered on a constant time basis. In the second example, which illustrates the situation where a non-real time service is carried by the Transport Channel, the number of blocks delivered per Transmission Time Interval varies between the different Transport Formats within the Transport Format Set. Referring to Figure 6, the Transport Block Size is varied on DCH1 whereas the Transport Block Set Size is fix. That is, a Transport Format Set where the dynamic part has a variable Transport Block Size has been assigned for DCH1. On DCH2 and DCH3 it is instead the Transport Block Set Sizes that are varied. That is, the dynamic parts of the corresponding Transport Format Sets include variable Transport Block Set Sizes.

7.1.7 Transport Format Combination

The layer 1 multiplexes one or several Transport Channels, and for each Transport Channel, there exists a list of transport formats (Transport Format Set) which are applicable. Nevertheless, at a given point of time, not all combinations may be submitted to layer 1 but only a subset, the Transport Format Combination. This is defined as an

authorised combination of the combination of currently valid Transport Formats that can be submitted simultaneously to the layer 1 for transmission on a Coded Composite Transport Channel of a UE, i.e. containing one Transport Format from each Transport Channel.

Example:

DCH1: Dynamic part: {20 bits, 20 bits}, Semi-static part: {10ms, Inner coding only, repeat 1/12 of the bits}

DCH2: Dynamic part: {320 bits, 1280 bits}, Semi-static part: {10ms, Inner coding only, puncture 1/14 of the bits}

DCH3: Dynamic part: {320 bits, 320 bits}, Semi-static part: {40ms, Outer coding, repeat 1/20 of the bits}

7.1.8 Transport Format Combination Set

This is defined as a set of Transport Format Combinations on a Coded Composite Transport Channel.

Example:

Dynamic part:

Combination 1: DCH1: {20 bits, 20 bits}, DCH2: {320 bits, 1280 bits}, DCH3: {320 bits, 320 bits}

Combination 2: DCH1: {40 bits, 40 bits}, DCH2: {320 bits, 1280 bits}, DCH3: {320 bits, 320 bits}

Combination 3: DCH1: {160 bits, 160 bits}, DCH2: {320 bits, 320 bits}, DCH3: {320 bits, 320 bits}

Semi-static part:

DCH1: {10ms, Inner coding only, repeat 1/12 of the bits}

DCH2: {10ms, Inner coding only, puncture 1/14 of the bits}

DCH3: {40ms, Outer coding, repeat 1/20 of the bits}

The Transport Format Combination Set is what is given to MAC for control. However, the assignment of the Transport Format Combination Set is done by L3. When mapping data onto L1, MAC chooses between the different Transport Format Combinations given in the Transport Format Combination Set. Since it is only the dynamic part that differ between the Transport format Combinations, it is in fact only the dynamic part that MAC has any control over.

The semi-static part, together with the target value for the L1 closed loop power control, correspond to the service attributes:

- Quality (e.g. BER)
- Transfer delay

These service attributes are then offered by L1. However, it is L3 that guarantees that the L1 services are fulfilled since it is in charge of controlling the L1 configuration, i.e. the setting of the semi-static part of the Transport Formats. Furthermore, L3 controls the target for the L1 closed loop power control through the outer loop power control (which actually is a quality control rather than a power control).

Note that a Transport Format Combination Set need not contain all possible Transport Format Combinations that can be formed by Transport Format Sets of the corresponding Transport Channels. It is only the allowed combinations that are included. Thereby a maximum total bit rate of all transport channels of a Code Composite Transport Channel can be set appropriately. That can be achieved by only allowing Transport Format Combinations for which the included Transport Formats (one for each Transport Channel) do not correspond to high bit rates simultaneously.

The selection of Transport Format Combinations can be seen as a fast part of the radio resource control. The dedication of these fast parts of the radio resource control to MAC, close to L1, means that the flexible variable rate scheme provided by L1 can be fully utilised. These parts of the radio resource control should be distinguished from the slower parts, which are handled by L3. Thereby the bit rate can be changed very fast, without any need for L3 signalling.

7.1.9 Transport Format Indicator (TFI)

The TFI is a label for a specific transport format within a transport format set. It is used in the inter-layer communication between MAC and L1 each time a transport block set is exchanged between the two layers on a transport channel.

7.1.10 Transport Format Combination Indicator (TFCI)

This is a representation of the current Transport Format Combination.

There is a one-to-one correspondence between a certain value of the TFCI and a certain Transport Format Combination. The TFCI is used in order to inform the receiving side of the currently valid Transport Format Combination, and hence how to decode, de-multiplex and deliver the received data on the appropriate Transport Channels.

MAC indicates the TFI to Layer 1 at each delivery of Transport Block Sets on each Transport Channel. Layer 1 then builds the TFCI from the TFIs of all parallel transport channels of the UE, processes the Transport Blocks appropriately and appends the TFCI to the physical control signalling. Through the detection of the TFCI the receiving side is able to identify the Transport Format Combination. For FDD, in case of limited Transport Format Combination Sets the TFCI signalling may be omitted, instead relying on blind detection. Nevertheless, from the assigned Transport Format Combinations, the receiving side has all information it needs in order to decode the information and transfer it to MAC on the appropriate Transport Channels.

The multiplexing and exact rate matching patterns follow predefined rules and may therefore be derived (given the Transport Format Combinations) by transmitter and receiver without signalling over the radio interface.

When the meaning of the TFCI field needs to be reconfigured, two procedures can be used depending on the level of reconfiguration:

- **Complete reconfiguration of TFCI:** In this procedure all TFCI values are reinitialized and new values are defined instead. The complete reconfiguration requires an explicit synchronization between the UE and UTRAN regarding when the reconfiguration becomes valid.
- **Incremental reconfiguration of TFCI:** In this procedure, a part of the TFCI values before and after the reconfiguration remain identical (note that this must be true for at least a TFCI that carry the signaling connection). This procedure supports addition, removal or redefinition of TFCI values. This procedure does not require an explicit execution time.

7.2 Types of Transport Channels

A general classification of transport channels is into two groups:

- common channels (where there is a need for in-band identification of the UEs when particular UEs are addressed) and
- dedicated channels (where the UEs are identified by the physical channel, i.e. code and frequency)

Common transport channel types are:

1. Random Access Channel(s) (RACH) characterized by:

- existence in uplink only,
- limited data field. The exact number of allowed bits is FFS.
- collision risk,
- open loop power control,
- requirement for in-band identification of the UEs.

2. ODMA Random Access Channel(s) (ORACH) characterized by:

- used in TDD mode only (FDD is for FFS)
- existence in relay-link
- collision risk,
- open loop power control,
- no timing advance control
- requirement for in-band identification of the UE.

3. Forward Access Channel(s) (FACH) characterized by:

- existence in downlink only,
- possibility to use beam forming,
- possibility to use slow power control,
- possibility to change rate fast (each 10ms),
- lack of fast power control and
-

4. Broadcast Channel (BCH) characterized by:

- existence in downlink only,
- low fixed bit rate and
- requirement to be broadcast in the entire coverage area of the cell.

5. Paging Channel (PCH) characterized by:

- existence in downlink only,
- possibility for sleep mode procedures and
- requirement to be broadcast in the entire coverage area of the cell.

6. Synchronisation channel (SCH) characterised by :

- existence in TDD and downlink only
- low fixed bit rate
- requirement to be broadcast in the entire coverage area of the cell

7. Downlink Shared Channel(s) (DSCH) characterised by:

- existence in downlink only,
- possibility to use beamforming,
- possibility to use slow power control,
- possibility to use fast power control, when associated with dedicated channel(s)
- possibility to be broadcast in the entire cell
- always associated with another channel (DCH or DSCH Control Channel).

8. DSCH Control Channel characterised by:

- existence in downlink only,
- possibility to use beam forming,
- possibility to use slow power control,
- lack of fast power control and
-

Editor's note: It is for further study whether or not the DSCH Control Channel needs to be regarded as separate transport channel type from FACH. Seen from the upper layers, the current requirements are identical to a FACH, but some extra L1 information (e.g.TPC bits) may lead to a different physical channel.

1. Uplink Shared channel (USCH) characterised by:

- used in TDD only
- existence in uplink only,
- possibility to use beam forming,
- possibility to use power control,

- possibility to change rate fast

Dedicated transport channel types are:

1. Dedicated Channel (DCH) characterized by:

- existing in uplink or downlink
- possibility to use beam forming,
- possibility to change rate fast (each 10ms),
- fast power control and
- inherent addressing of UEs.

2. Fast Uplink Signaling Channel (FAUSCH) to allocate, in conjunction with FACH, dedicated channels; the FAUSCH is characterized by:

- existing in uplink only,
- inherent addressing of a UE by a unique time-offset (indicating to a UE when to send an uplink signalling code, USC) related to the beginning of the 10 ms frame,
- allowing for a UE to notify (by sending an USC) a request for a DCH, the allocation of which is messaged via the FACH. No further information is conveyed via the FAUSCH,
- applicability for TDD mode is FFS.

3. ODMA Dedicated Channel (ODCH) characterized by:

- used in TDD mode only (FDD is for FFS),
- possibility to use beam forming,
- possibility to change rate fast (each 10ms),
- closed loop power control,
- closed loop timing advance control,
- temporary addressing of UE.

To each transport channel (except for the FAUSCH, since it only conveys a reservation request), there is an associated Transport Format (for transport channels with a fixed or slow changing rate) or an associated Transport Format Set (for transport channels with fast changing rate).

7.3 Slotted Mode

Slotted Mode is defined as the mechanism whereby certain idle periods are created in downlink radio frames so that the UE can perform measurement reports during these periods (more details can be found in [3]). Applicability to uplink is FFS.

Slotted Mode is obtained by layer 2 using transport channels provided by the layer 1 as follows :

- Slotted Mode is controlled by the RRC layer which configures the layer 2 and the physical layer
- The number of occurrences of slotted frames is controlled by RRC, and can be modified by RRC signalling
- Layer 2 instructs every Transmission Time Interval the Layer 1 on whether slotted mode should be applied for a given Transport Format Combination Set. The instruction may indicate also the type of slotted mode (beginning, middle or end of the frame).
- The slotting can be either cyclic (typically for circuit services) or a-periodic (typically for NRT services)
- It is under the responsibility of the layer 2 if necessary to either buffer some layer 2 PDUs (typically at the RLC layer for NRT services) or to rate adapt the data flow (similarly to GSM) so that there is no loss of data because of slotted mode. This will be service dependant and controlled by the RRC layer.

Primitives of the physical layer

The Physical layer interacts with other entities as illustrated in figure 2.1. The interactions with the MAC layer and the RRC layer are shown in terms of primitives where the primitives represent the logical exchange of information and control between the physical layer and higher layers. They do not specify or constrain implementations. For the physical layer two sets of primitives are defined:

* **Primitives between layer 1 and 2:**

PHY - Generic name - Type: Parameters.

* **Primitives between layer 1 and the RRC entity:**

CPHY - Generic name - Type: Parameters.

8.1 Generic names of primitives between layers 1 and 2

Editor's note : the following list of primitives contains the first part of the generic primitives between the physical layer and upper layers. It is not complete yet. Further primitives will be incorporated when the modelling of the physical layer is further refined. In particular, most of the parameters to the primitives are FFS.

8.1.1 PHY-CONNECT

Note: This primitive is FFS. It could potentially be used by MAC for activating reception of the physical channel that carries DSCH if MAC signalling is used for DSCH resource allocation, i.e. in the case of MAC signalling on a DSCH control channel (c.f. Case B in S2.01). Will there be additional use for it in the TDD mode?

The PHY-CONNECT primitives are used to request activation of the physical layer connection or to confirm that the physical layer connection has been activated.

Primitives: request, confirm.

Request parameters:

- FFS

Confirm parameters:

- FFS

8.1.2 PHY-DISCONNECT

Note: This primitive is FFS. It could potentially be used by MAC for de-activating reception of the physical channel that carries DSCH if MAC signalling is used for DSCH resource allocation, i.e. in the case of MAC signalling on a DSCH control channel (c.f. Case B in S2.01). Will there be additional use for it in the TDD mode?

The PHY-DISCONNECT primitives are used to request deactivation of the physical layer connection or to indicate that the physical layer connection has been deactivated.

Primitives: request, indication (FFS)

Request parameters:

- FFS

Indication Parameters

- FFS

8.1.3 PHY-DATA

The PHY-DATA primitives are used to request and indicate SDUs used for Layer 2 peer to peer communications passed to and from the physical layer. One PHY-DATA primitive is submitted every Transmission Time Interval for each Transport Channel.

Primitives: request, indication.

Parameters:

- TFI
- Type of slotted mode (e.g. no slotting, slotting of beginning/middle/end of frame)
- Transport Block Set
- CRC check result (indication only)
- FFS

8.1.4 PHY-STATUS

The PHY-STATUS primitive can be used by the layer 1 to notify higher layers of an event which has occurred.

Primitives: indication

Parameters

- Event value
 3. Maximum transmission power has been reached
- Transmission power
 4. Allowable transmission power has been reached
 5. Average transmission power is below allowable transmission power

8.2 Generic names of primitives between layers 1 and 3

8.2.1 STATUS PRIMITIVES

8.2.1.1 CPHY-Sync

This primitive is used for L1 to indicate to RRC that synchronisation of a certain physical channel has been done in the receiver.

Primitives:

CPHY-Sync-IND

Parameters:

FFS

8.2.1.2 CPHY-Out-of-Sync

Primitive sent from L1 to RRC indicating that synchronisation of a previously configured connection has been lost in the receiver.

Primitives:

CPHY-Out-of-Sync-IND

Parameters:

FFS

8.2.1.3 CPHY-Measurement

The Request primitive is used for RRC to configure L1 measurements. The Indication primitive is used to report the measurement result from L1 to RRC.

Primitives:

CPHY-Measurement-REQ

CPHY-Measurement-IND

[Note: The need for a CPHY-Measurement CNF is FFS.]

Parameters:

Transmission quality parameters

FFS

8.2.1.4 CPHY-ERROR

The CPHY-ERROR primitive is used to indicate to the management entity that an error has occurred as a result of a physical layer fault.

Primitives: indication

Indication Parameters

- Error Code

8.2.2 CONTROL PRIMITIVES

8.2.2.1 CPHY-TrCH-Config

This primitive is used for setting up and configuring a transport channel, and also to modify an existing transport channel.

Primitives:

CPHY-TrCH-Config-REQ

CPHY-TrCH-Config-CNF

Parameters:

FFS

8.2.2.2 CPHY-TrCH-Release

This primitive is used for releasing a transport channel.

Primitives:

CPHY-TrCH-Release-REQ

CPHY-TrCH-Release-CNF

Parameters:

FFS

8.2.2.3 CPHY-Setup

The Request primitive is sent from RRC to L1 for establishment of a Radio link to a certain UE. The Confirm primitive is returned from L1 to RRC when the Radio link is established. In case L1 is unable to execute the request, this is indicated in the confirm primitive.

Primitives:

CPHY-Setup-REQ

CPHY-Setup-CNF

Parameters:

Physical channel description

8.2.2.4 CPHY-Release

The Request primitive is sent from RRC to L1 for release of a Radio link to a certain UE. The Confirm primitive is returned from L1 to RRC when the radio link is released.

Primitives:

CPHY-Release-REQ

CPHY-Release-CNF

Parameters:

FFS

8.2.2.5 CPHY-Modify

The Request primitive is sent from RRC to L1 for modification of a Radio link to a certain UE. The Confirm primitive is returned from L1 to RRC when the radio link is modified. In case L1 is unable to execute the request, this is indicated in the confirm primitive.

Primitives:

CPHY-Modify-REQ

CPHY-Modify-CNF

Parameters:

Physical channel description

8.3 Parameter definition

8.3.1 Received transmission quality parameters

	Request	Indication
Radio link list	-	-
SIR threshold	-	
FER threshold	-	
SIR measured		-
FER measured		-

8.3.2 Radio link to be reported

8.3.3 Error code

ffs

8.3.4 Physical channel description

	Primary SCH	Secondary SCH	Primary CCPCH	Secondary CCPCH	PRACH	DPCH
Radio frequency	-					-
Primary Synchronisation code	-					
Secondary Synchronisation code		-				
Scrambling code			-	-	-	-
Channelisation code			-	-	-	-
Available Access slot					-	
Transmission Power level					-	
Preamble signature					-	
Frame Offset				-		-

8.3.5 Action

	Primary SCH	Secondary SCH	Primary CCPCH	Secondary CCPCH	PRACH	DPCH
Activate Radio link	-	-	-	-	-	-
Deactivate Radio link	-	-	-	-	-	-

9 Radio Frame transmission

9.1 Downlink Frame format

9.2 Uplink Frame format

9.3 Order of bit transmission

Annex A: Example of table that describes a Transport Format Set

The following table describes the characterisation of a Transport Format Set. The possible values for the attributes will be defined by the L1 experts group based on the requirements identified by the L23 experts group. Note that the allowed Transport Format Combinations are not described here, and will need to be covered also.

		Attribute values
Dynamic part	Transport Block Size	list of values
	Transport Block Set Size	list of values
	Transmission Time Interval (option for TDD only)	list of values
Semi-static part	Transmission Time Interval (FDD, option for TDD NRT bearers)	Value
	Type of channel coding	Value
	Outer coding	Value
	Outer interleaving	Value
	Inner coding	Value
	Inner interleaving	Value
	Rate matching	Value

10History

Document history		
Date	Version	Comment
January 1999	0.0.0	Starting point based on UMTS YY.02 V1.2.0 (ETSI SMG2/UMTS-L23 60/99)
January 1999	0.0.1	version after TSG RAN WG2 #1 based on the agreed changes after review of Tdoc TSG RAN WG2 025/99.
March 1999	0.1.0	Same as version 0.0.1 with changes approved. Format has been updated according to 3GPP template.
April 1999	0.1.1	version after TSG RAN WG2 #2 based on agreed changes proposed by Tdoc TSG RAN WG2 151/99
April 1999	0.1.2	Re-issue (application of Tdoc TSG RAN WG2 187/99)
April 1999	0.2.0	version based on agreed changes proposed by Tdocs TSG RAN WG2 298/99 & 318/99.
April 1999	0.3.0	version after TSG RAN WG2 #3. Slight editorial changes. Document approved by TSG RAN WG3.
April 1999	2.0.0	Endorsed by TSG-RAN as TS 25.302 V2.0.0
Rapporteur for TS 25.302 is :		
Pierre Lescuyer Nortel Networks Tel: +33 1 39 44 44 86 Fax: +33 1 39 44 50 02 email: lescuyc@nortelnetworks.com		
This document is written in Microsoft Word version 6.0.		