

Berlin/Germany

August 22nd – 25th, 2000

Agenda Item: Correction to R'99

Source: Siemens AG, Mitsubishi Electric

Title: CR026r2 for TS25.221

Document for: Approval

Summary

CR026r1 has already been approved at WG1#14 in Oulu/Finland. A Rev2 of this CR is necessary for consistency reasons with CR031 to 25.221, if the later is accepted. The only difference between Rev1 and Rev2 of CR026 occurs in section 5.6.1 on midamble allocation for DL physical channels, where the proposed

"For DL physical channels that are located in the same time slot as the P-CCPCH, midambles shall be allocated by default, using the association for burst type 1 and K=8 midambles."

is not included any more in Rev2. The same statement, but with a wording slightly changed, is already introduced by CR031 to 25.221 to the corresponding section.

| | | | |
|---|--|--|--|
| CHANGE REQUEST | | | Please see embedded help file at the bottom of this page for instructions on how to fill in this form correctly. |
| 25.221 | CR | 026r2 | Current Version: 3.3.0 |
| GSM (AA.BB) or 3G (AA.BBB) specification number ↑ | | ↑ CR number as allocated by MCC support team | |
| For submission to: RAN#9 <small>list expected approval meeting # here</small> | for approval <input checked="" type="checkbox"/> | for information <input type="checkbox"/> | strategic <input type="checkbox"/> (for SMG use only) non-strategic <input type="checkbox"/> |

Form: CR cover sheet, version 2 for 3GPP and SMG The latest version of this form is available from: <ftp://ftp.3gpp.org/Information/CR-Form-v2.doc>

Proposed change affects: (U)SIM ME UTRAN / Radio Core Network
(at least one should be marked with an X)

Source: Siemens AG, Mitsubishi Electric **Date:** 22/08/00

Subject: Some corrections for TS25.221

Work item:

| | | | |
|------------------|--|-----------------|--|
| Category: | F Correction <input checked="" type="checkbox"/> A Corresponds to a correction in an earlier release <input type="checkbox"/> B Addition of feature <input type="checkbox"/> C Functional modification of feature <input type="checkbox"/> D Editorial modification <input type="checkbox"/> | Release: | Phase 2 <input type="checkbox"/> Release 96 <input type="checkbox"/> Release 97 <input type="checkbox"/> Release 98 <input type="checkbox"/> Release 99 <input checked="" type="checkbox"/> Release 00 <input type="checkbox"/> |
|------------------|--|-----------------|--|

(only one category shall be marked with an X)

Reason for change:

The following changes are included in this CR:

- Removal of a remaining reference to ODMA
- Correction of the PI to bit mapping and aligning terminology with WG2/WG3
- Alignment with FDD regarding 'Indicator Channel' Terminology
- Extension of Abbreviations and References
- Correction of Multiframe Structures in Annex
- Correction of UL TS format numbering
- Correction of DTrCH mapping
- Correction of a reference to TS25.302
- Modification of SCH figure

Clauses affected: 3; 4; 5.2.2.3.2; 5.3.1.3; 5.3.4; 5.3.7; 5.5.2; 5.6.1; 6; Annex B

| | | | |
|------------------------------|---|--|--|
| Other specs affected: | Other 3G core specifications <input type="checkbox"/> Other GSM core specifications <input type="checkbox"/> MS test specifications <input type="checkbox"/> BSS test specifications <input type="checkbox"/> O&M specifications <input type="checkbox"/> | → List of CRs: → List of CRs: → List of CRs: → List of CRs: → List of CRs: | |
|------------------------------|---|--|--|

Other comments:



<----- double-click here for help and instructions on how to create a CR.

2 References

The following documents contain provisions which, through reference in this text, constitute provisions of the present document.

- References are either specific (identified by date of publication, edition number, version number, etc.) or non-specific.
- For a specific reference, subsequent revisions do not apply.
- For a non-specific reference, the latest version applies.

- [1] 3G TS 25.201: "Physical layer - general description".
- [2] 3G TS 25.211: "Physical channels and mapping of transport channels onto physical channels (FDD)".
- [3] 3G TS 25.212: "Multiplexing and channel coding (FDD)".
- [4] 3G TS 25.213: "Spreading and modulation (FDD)".
- [5] 3G TS 25.214: "Physical layer procedures (FDD)".
- [6] 3G TS 25.215: "Physical layer – Measurements (FDD)".
- [7] 3G TS 25.222: "Multiplexing and channel coding (TDD)".
- [8] 3G TS 25.223: "Spreading and modulation (TDD)".
- [9] 3G TS 25.224: "Physical layer procedures (TDD)".
- [10] 3G TS 25.225: "Physical layer – Measurements (TDD)".
- [11] 3G TS 25.301: "Radio Interface Protocol Architecture".
- [12] 3G TS 25.302: "Services Provided by the Physical Layer".
- [13] 3G TS 25.401: "UTRAN Overall Description".
- [14] 3G TS 25.402: "Synchronisation in UTRAN, Stage 2".
- [15] 3G TS 25.304: "-UE Procedures in Idle Mode and Procedures for Cell Reselection in Connected Mode".
- [16] [3G TS 25.427: "UTRAN Iur and Iub interface user plane protocols for DCH data streams".](#)

3 Abbreviations

For the purposes of the present document, the following abbreviations apply:

| | |
|--------------------------|---|
| BCH | Broadcast Channel |
| CCPCH | Common Control Physical Channel |
| CCTrCH | Coded Composite Transport Channel |
| CDMA | Code Division Multiple Access |
| DPCH | Dedicated Physical Channel |
| DRX | Discontinuous Reception |
| DSCH | Downlink Shared Channel |
| FACH | Forward Access Channel |
| FDD | Frequency Division Duplex |
| FEC | Forward Error Correction |
| GP | Guard Period |
| GSM | Global System for Mobile Communication |
| NRT | Non-Real Time |
| OVSF | Orthogonal Variable Spreading Factor |
| P-CCPCH | Primary CCPCH |
| PCH | Paging Channel |
| PDSCH | Physical Downlink Shared Channel |
| PDU | Protocol Data Unit |
| PI | Paging Indicator (value calculated by higher layers) |
| PICH | Pageing Indicator Channel |
| P_q | Paging Indicator (indicator set by physical layer) |
| PRACH | Physical Random Access Channel |
| PUSCH | Physical Uplink Shared Channel |
| RACH | Random Access Channel |
| RLC | Radio Link Control |
| RF | Radio Frame |
| RT | Real Time |
| S-CCPCH | Secondary CCPCH |
| SCH | Synchronisation Channel |
| SFN | Cell System Frame Number |
| TCH | Traffic Channel |
| TDD | Time Division Duplex |
| TDMA | Time Division Multiple Access |
| TrCH | Transport Channel |
| UE | User Equipment |
| USCH | Uplink Shared Channel |

4 Services offered to higher layersTransport channels

4.1 Transport channels

Transport channels are the services offered by layer 1 to the higher layers. A transport channel is defined by how and with what characteristics data is transferred over the air interface. A general classification of transport channels is into two groups:

- Dedicated Channels, using inherent addressing of UE
- Common Channels, using explicit addressing of UE if addressing is needed

General concepts about transport channels are described in [\[12\]3GPP RAN TS 25.302 \(L2 specification\)](#).

4.1.1 Dedicated transport channels

The Dedicated Channel (DCH) is an up- or downlink transport channel that is used to carry user or control information between the UTRAN and a UE.

4.1.2 Common transport channels

There are six types of transport channels: BCH, FACH, PCH, RACH, USCH, DSCH

4.1.2.1 BCH - Broadcast Channel

The Broadcast Channel (BCH) is a downlink transport channel that is used to broadcast system- and cell-specific information.

4.1.2.2 FACH – Forward Access Channel

The Forward Access Channel (FACH) is a downlink transport channel that is used to carry control information to a mobile station when the system knows the location cell of the mobile station. The FACH may also carry short user packets.

4.1.2.3 PCH – Paging Channel

The Paging Channel (PCH) is a downlink transport channel that is used to carry control information to a mobile station when the system does not know the location cell of the mobile station.

4.1.2.4 RACH – Random Access Channel

The Random Access Channel (RACH) is an up link transport channel that is used to carry control information from mobile station. The RACH may also carry short user packets.

4.1.2.5 USCH – Uplink Shared Channel

The uplink shared channel (USCH) is an uplink transport channel shared by several UEs carrying dedicated control or traffic data.

4.1.2.6 DSCH – Downlink Shared Channel

The downlink shared channel (DSCH) is a downlink transport channel shared by several UEs carrying dedicated control or traffic data.

4.2 Indicators

Indicators are means of fast low-level signalling entities which are transmitted without using information blocks sent over transport channels. The meaning of indicators is implicit to the receiver.

The indicator(s) defined in the current version of the specifications are: [Paging Indicator](#).

5.2.2.3.2 Uplink timeslot formats

The uplink timeslot format depends on the spreading factor, midamble length and on the number of the TFCI bits. Due to TPC, different amount of bits are mapped to the two data fields. The timeslot formats are depicted in the table 4b.

Table 4b: Timeslot formats for the Uplink

| Slot Format # | Spreading Factor | Midamble length (chips) | N _{TFCI} (bits) | N _{TPC} (bits) | Bits/slot | N _{Data/Slot} (bits) | N _{data/data field(1)} (bits) | N _{data/data field(2)} (bits) |
|-----------------|------------------|-------------------------|--------------------------|-------------------------|-----------|-------------------------------|--|--|
| 0 | 16 | 512 | 0 | 0 | 244 | 244 | 122 | 122 |
| 51 | 16 | 512 | 0 | 2 | 244 | 242 | 122 | 120 |
| 26 | 16 | 512 | 4 | 2 | 244 | 238 | 120 | 118 |
| 37 | 16 | 512 | 8 | 2 | 244 | 234 | 118 | 116 |
| 48 | 16 | 512 | 16 | 2 | 244 | 226 | 114 | 112 |
| 59 | 16 | 512 | 32 | 2 | 244 | 210 | 106 | 104 |
| 640 | 16 | 256 | 0 | 0 | 276 | 276 | 138 | 138 |
| 745 | 16 | 256 | 0 | 2 | 276 | 274 | 138 | 136 |
| 846 | 16 | 256 | 4 | 2 | 276 | 270 | 136 | 134 |
| 947 | 16 | 256 | 8 | 2 | 276 | 266 | 134 | 132 |
| 108 | 16 | 256 | 16 | 2 | 276 | 258 | 130 | 128 |
| 119 | 16 | 256 | 32 | 2 | 276 | 242 | 122 | 120 |
| 1220 | 8 | 512 | 0 | 0 | 488 | 488 | 244 | 244 |
| 1325 | 8 | 512 | 0 | 2 | 488 | 486 | 244 | 242 |
| 1426 | 8 | 512 | 4 | 2 | 488 | 482 | 242 | 240 |
| 1527 | 8 | 512 | 8 | 2 | 488 | 478 | 240 | 238 |
| 1628 | 8 | 512 | 16 | 2 | 488 | 470 | 236 | 234 |
| 1729 | 8 | 512 | 32 | 2 | 488 | 454 | 228 | 226 |
| 1830 | 8 | 256 | 0 | 0 | 552 | 552 | 276 | 276 |
| 1935 | 8 | 256 | 0 | 2 | 552 | 550 | 276 | 274 |
| 2036 | 8 | 256 | 4 | 2 | 552 | 546 | 274 | 272 |
| 2137 | 8 | 256 | 8 | 2 | 552 | 542 | 272 | 270 |
| 2238 | 8 | 256 | 16 | 2 | 552 | 534 | 268 | 266 |
| 2339 | 8 | 256 | 32 | 2 | 552 | 518 | 260 | 258 |
| 2440 | 4 | 512 | 0 | 0 | 976 | 976 | 488 | 488 |
| 2545 | 4 | 512 | 0 | 2 | 976 | 974 | 488 | 486 |
| 2646 | 4 | 512 | 4 | 2 | 976 | 970 | 486 | 484 |
| 2747 | 4 | 512 | 8 | 2 | 976 | 966 | 484 | 482 |
| 2848 | 4 | 512 | 16 | 2 | 976 | 958 | 480 | 478 |
| 2949 | 4 | 512 | 32 | 2 | 976 | 942 | 472 | 470 |
| 3050 | 4 | 256 | 0 | 0 | 1104 | 1104 | 552 | 552 |
| 3155 | 4 | 256 | 0 | 2 | 1104 | 1102 | 552 | 550 |
| 3256 | 4 | 256 | 4 | 2 | 1104 | 1098 | 550 | 548 |
| 3357 | 4 | 256 | 8 | 2 | 1104 | 1094 | 548 | 546 |
| 3458 | 4 | 256 | 16 | 2 | 1104 | 1086 | 544 | 542 |
| 3559 | 4 | 256 | 32 | 2 | 1104 | 1070 | 536 | 534 |
| 3660 | 2 | 512 | 0 | 0 | 1952 | 1952 | 976 | 976 |
| 3765 | 2 | 512 | 0 | 2 | 1952 | 1950 | 976 | 974 |
| 3866 | 2 | 512 | 4 | 2 | 1952 | 1946 | 974 | 972 |
| 3967 | 2 | 512 | 8 | 2 | 1952 | 1942 | 972 | 970 |
| 4068 | 2 | 512 | 16 | 2 | 1952 | 1934 | 968 | 966 |
| 4169 | 2 | 512 | 32 | 2 | 1952 | 1918 | 960 | 958 |
| 4270 | 2 | 256 | 0 | 0 | 2208 | 2208 | 1104 | 1104 |
| 4375 | 2 | 256 | 0 | 2 | 2208 | 2206 | 1104 | 1102 |
| 4476 | 2 | 256 | 4 | 2 | 2208 | 2202 | 1102 | 1100 |
| 4577 | 2 | 256 | 8 | 2 | 2208 | 2198 | 1100 | 1098 |
| 4678 | 2 | 256 | 16 | 2 | 2208 | 2190 | 1096 | 1094 |
| 4779 | 2 | 256 | 32 | 2 | 2208 | 2174 | 1088 | 1086 |

| Slot Format # | Spreading Factor | Midamble length (chips) | N _{TFCI} (bits) | N _{TPC} (bits) | Bits/slot | N _{Data/Slot} (bits) | N _{data/data field(1)} (bits) | N _{data/data field(2)} (bits) |
|---------------|------------------|-------------------------|--------------------------|-------------------------|-----------|-------------------------------|--|--|
| 4880 | 1 | 512 | 0 | 0 | 3904 | 3904 | 1952 | 1952 |
| 4985 | 1 | 512 | 0 | 2 | 3904 | 3902 | 1952 | 1950 |
| 5086 | 1 | 512 | 4 | 2 | 3904 | 3898 | 1950 | 1948 |
| 5187 | 1 | 512 | 8 | 2 | 3904 | 3894 | 1948 | 1946 |
| 5288 | 1 | 512 | 16 | 2 | 3904 | 3886 | 1944 | 1942 |
| 5389 | 1 | 512 | 32 | 2 | 3904 | 3870 | 1936 | 1934 |
| 5490 | 1 | 256 | 0 | 0 | 4416 | 4416 | 2208 | 2208 |
| 5595 | 1 | 256 | 0 | 2 | 4416 | 4414 | 2208 | 2206 |
| 5696 | 1 | 256 | 4 | 2 | 4416 | 4410 | 2206 | 2204 |
| 5797 | 1 | 256 | 8 | 2 | 4416 | 4406 | 2204 | 2202 |
| 5898 | 1 | 256 | 16 | 2 | 4416 | 4398 | 2200 | 2198 |
| 5999 | 1 | 256 | 32 | 2 | 4416 | 4282 | 2192 | 2190 |

5.3.1.3 P-CCPCH Training sequences

The training sequences, i.e. midambles, as described in subclause 5.2.3 are used for the P-CCPCH. For those timeslots in which the P-CCPCH is transmitted, the midambles $m^{(1)}$, and $m^{(2)}$, ~~$m^{(9)}$ and $m^{(10)}$~~ are reserved for P-CCPCH in order to support Block STTD antenna diversity and the beacon function, see 5.4 and 5.5. The use of midambles depends on whether Block STTD is applied to the P-CCPCH:

- If no antenna diversity is applied to P-CCPCH, $m^{(1)}$ is used and $m^{(2)}$ is left unused;
- If Block STTD antenna diversity is applied to P-CCPCH, $m^{(1)}$ is used for the first antenna and $m^{(2)}$ is used for the diversity antenna.

~~The midambles $m^{(9)}$ and $m^{(10)}$ are always left unused in the P-CCPCH time slots.~~

5.3.4 The synchronisation channel (SCH)

In TDD mode code group of a cell can be derived from the synchronisation channel. In order not to limit the uplink/downlink asymmetry the SCH is mapped on one or two downlink slots per frame only.

There are two cases of SCH and P-CCPCH allocation as follows:

Case 1) SCH and P-CCPCH allocated in TS#k, $k=0\dots14$

Case 2) SCH allocated in two TS: TS#k and TS#k+8, $k=0\dots6$; P-CCPCH allocated in TS#k.

The position of SCH (value of k) in frame can change on a long term basis in any case.

Due to this SCH scheme, the position of P-CCPCH is known from the SCH.

Figure 14 is an example for transmission of SCH, $k=0$, of Case 2.

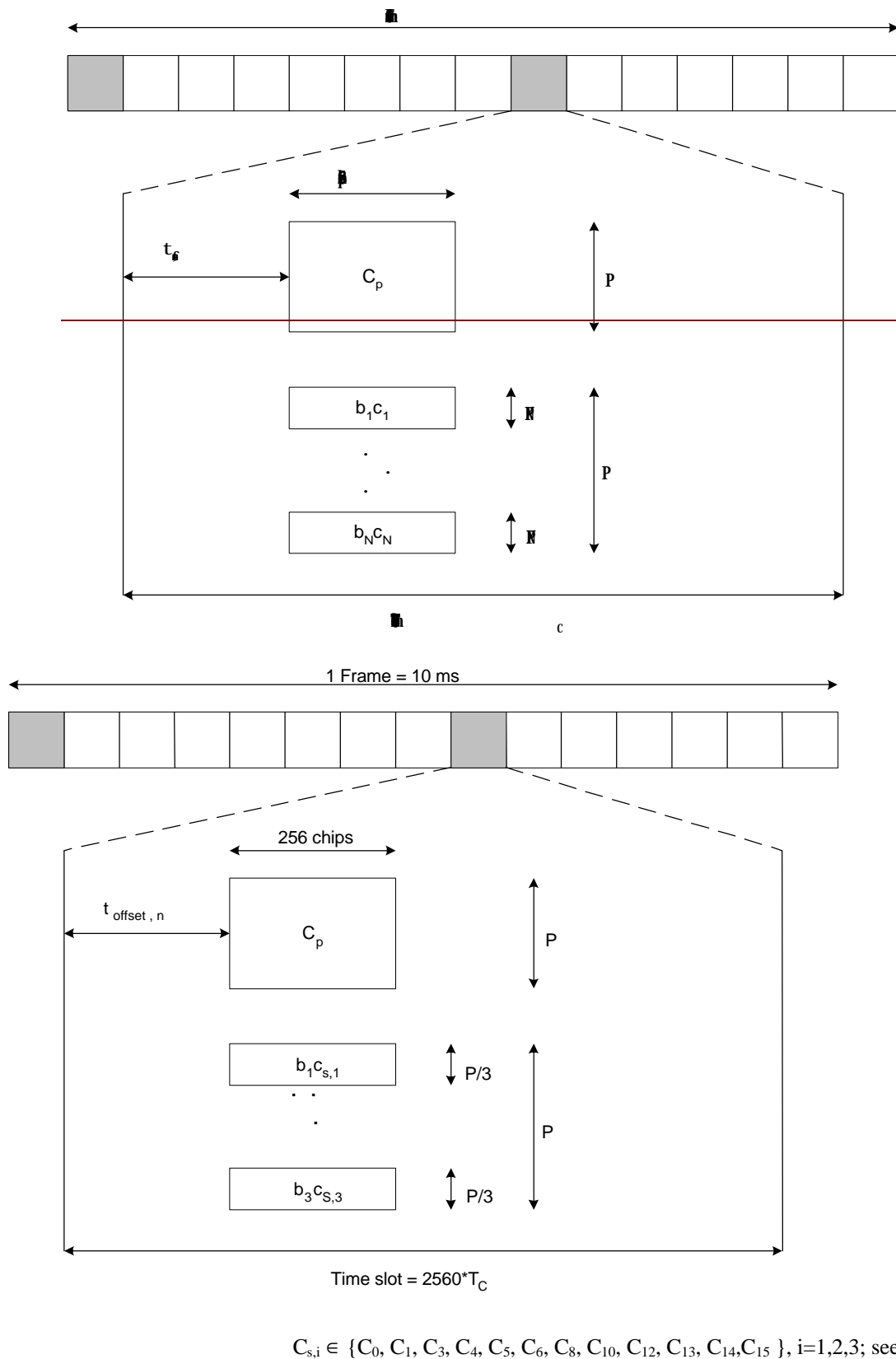

Figure 14: Scheme for Synchronisation channel SCH consisting of one primary sequence C_p and $N=3$ parallel secondary sequences $C_{s,i}$ in slot k and $k+8$ (example for $k=0$ in Case 2)

(example for $k=0$ in Case 2)

As depicted in figure 14, the SCH consists of a primary and three secondary code sequences with 256 chips length. The primary and secondary code sequences are defined in [8] clause 7 'Synchronisation codes'.

Due to mobile to mobile interference, it is mandatory for public TDD systems to keep synchronisation between base stations. As a consequence of this, a capture effect concerning SCH can arise. The time offset t_{offset} enables the system to overcome the capture effect.

The time offset t_{offset} is one of 32 values, depending on the cell parameter, thus on the code group of the cell, cf. 'table 6 Mapping scheme for Cell Parameters, Code Groups, Scrambling Codes, Midambles and t_{offset} ' in [8]. Note that the cell parameter will change from frame to frame, cf. 'Table 7 Alignment of cell parameter cycling and system frame number' in [8], but the cell will belong to only one code group and thus have one time offset t_{offset} . The exact value for t_{offset} , regarding column 'Associated t_{offset} ' in table 6 in [8] is given by:

$$\begin{aligned} t_{\text{offset},n} &= n \cdot T_c \left\lfloor \frac{2560 - 96 - 256}{31} \right\rfloor \\ &= n \cdot 71T_c ; \quad n = 0, \dots, 31 \end{aligned}$$

Please note that $\lfloor x \rfloor$ denotes the largest integer number less or equal to x and that T_c denotes the chip duration.

5.3.7 The Paging Indicator Channel (PICH)

The Paging Indicator Channel (PICH) is a physical channel used to carry the Paging Indicators (PI). The PICH is always transmitted at the same reference power level as the P-CCPCH.

Figure 15 depicts the structure of a PICH burst and the numbering of the bits within the burst. The same burst type is used for the PICH in every cell. N_{PIB} bits in a normal burst of type 1 or 2 are used to carry the Paging Indicators, where N_{PIB} depends on the burst type: $N_{PIB}=240$ for burst type 1 and $N_{PIB}=272$ for burst type 2. The bits $b_{N_{PIB}}, \dots, b_{N_{PIB}+3}$ adjacent to the midamble are reserved for possible future use. They shall be set to 0 and transmitted with the same power as the Paging Indicator carrying bits.

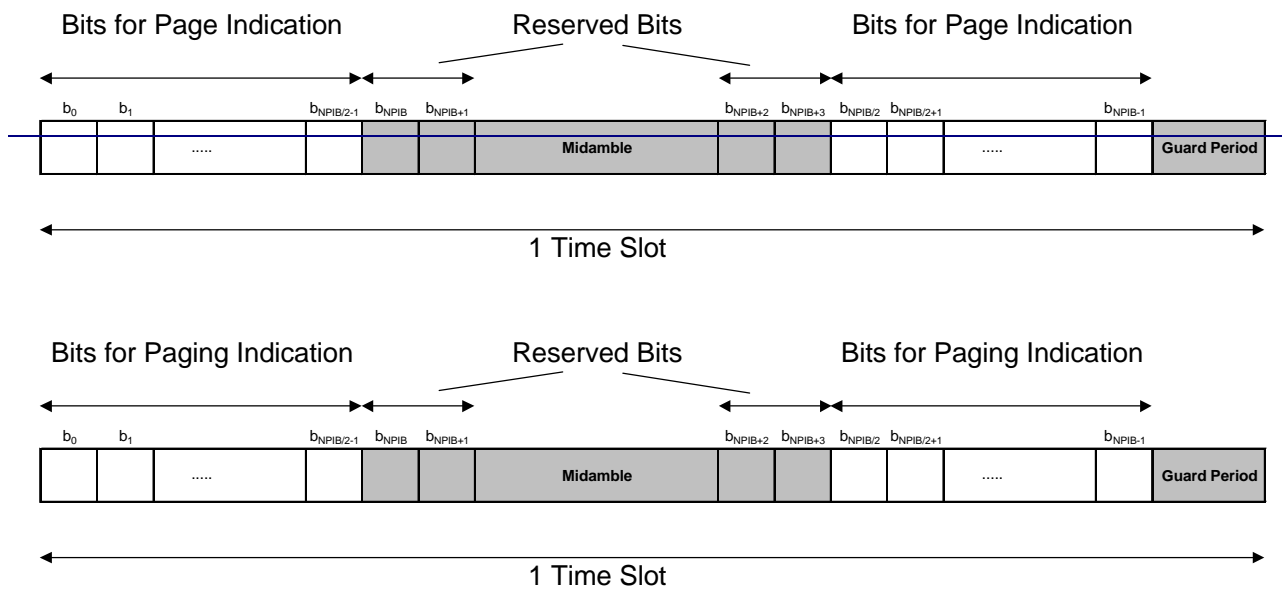

Figure 15: Transmission and numbering of Paging Indicator carrying bits in a PICH burst

In each time slot, N_{PI} paging indicators are transmitted, using of length $L_{PI}=42$, $L_{PI}=84$ or $L_{PI}=168$ bits/symbols are transmitted in one time slot. L_{PI} is called the paging indicator length. The number of paging indicators N_{PI} per time slot is given by the paging indicator length the number L_{PI} of bits for the page indicators and the burst type, which are both known by higher layer signalling. In table 8 this number is shown for the different possibilities of burst types and paging indicator lengths.

Table 8: Number N_{PI} of paging indicators per time slot for the different burst types and paging indicator lengths L_{PI}

| | $L_{PI}=42$ | $L_{PI}=84$ | $L_{PI}=168$ |
|--------------|-------------|-------------|--------------|
| Burst Type 1 | $N_{PI}=60$ | $N_{PI}=30$ | $N_{PI}=15$ |
| Burst Type 2 | $N_{PI}=68$ | $N_{PI}=34$ | $N_{PI}=17$ |

As shown in figure 16, the Paging Indicators of N_{PICH} consecutive frames form a PICH block, N_{PICH} is configured by higher layers. Thus, $N_P=N_{PICH} \cdot N_{PI}$ Paging Indicators are transmitted in each PICH block.

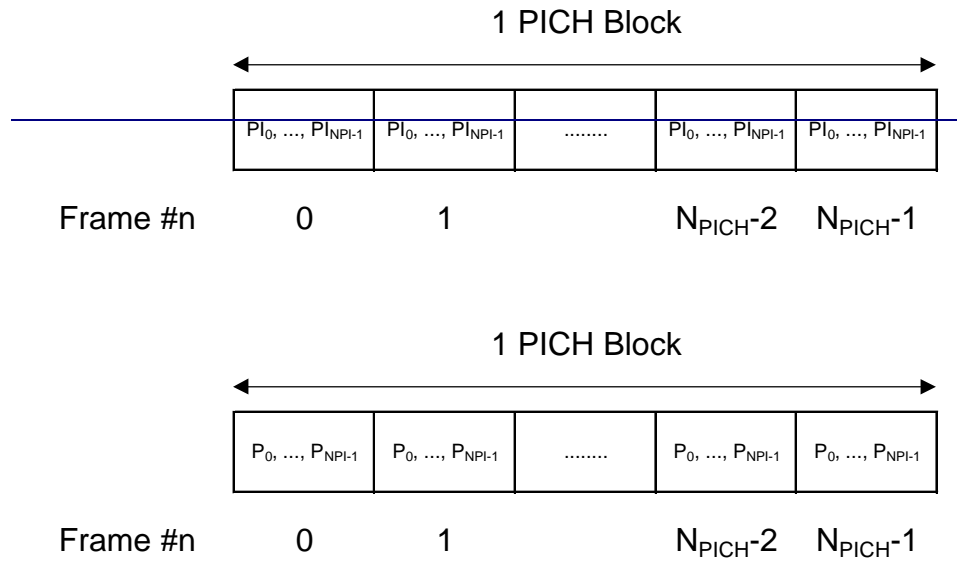

Figure 16: Structure of a PICH block

The value PI ($PI = 0, \dots, N_{PI}-1$) calculated by higher layers for use for a certain UE, see [15], is associated mapped to the paging indicator P_{pq} in the n th frame of one PICH block, where $p-q$ is given by

$$p-q = PI \bmod N_{PI}$$

and n is given by

$$n = PI \text{ div } N_{PI}$$

The PI bitmap in the PCH data frames over I_{ub} contains indication values for all possible higher layer PI values, see [16]. Each bit in the bitmap indicates if the paging indicator P_q associated with that particular PI shall be set to 0 or 1. Hence, the calculation in the formulas above is to be performed in Node B to make the association between PI and P_q .

The paging indicator P_{pq} in one time slot is mapped to the bits $\{b_{L_{PI} \cdot pq}, \dots, b_{L_{PI} \cdot pq + L_{PI} - 1}, b_{N_{PI}B/2 + L_{PI} \cdot pq}, \dots, b_{N_{PI}B/2 + L_{PI} \cdot pq + L_{PI} - 1}\}$ within this time slot, as exemplary shown in figure 17. Thus, half of the L_{PI} symbols used for each paging indicator are transmitted in the first data part, and the other half of the L_{PI} symbols are transmitted in the second data part.

The coding of the paging indicator P_q is given in [7].

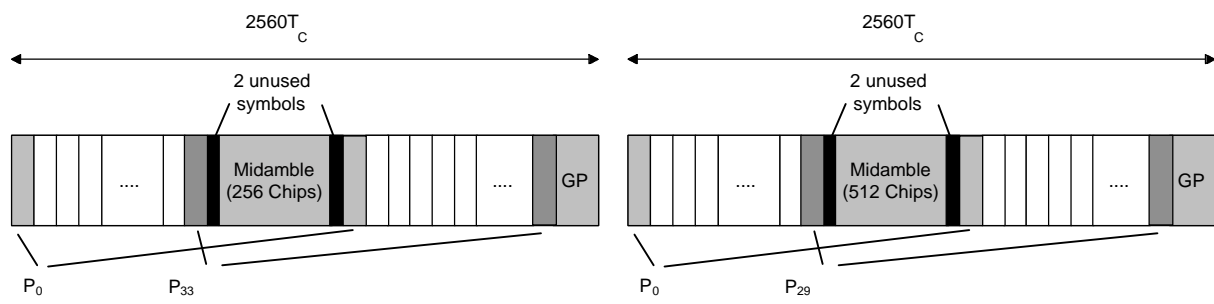

Figure 17: Example of mapping of paging indicators on PICH bits for $L_{PI}=4$

5.5.2 Physical characteristics of the beacon function

The physical channels providing the beacon function:

- are transmitted with reference power;
- are transmitted without beamforming;
- use burst type 1;
- use midamble $m_{\#}^{(1)}$ and $m^{(2)}$ exclusively in this time slot; and
- midambles $m_{\#}^{(9)}$ and $m^{(10)}$ are always left unused in this time slot, if 16 midambles are allowed in that cell.

Note that in the time slot where the P-CCPCH is transmitted only the midambles $m^{(1)}$ to $m^{(8)}$ shall be used, see 5.6.1. Thus, midambles $m^{(9)}$ and $m^{(10)}$ are always left unused in this time slot.

The reference power corresponds to the sum of the power allocated to both midambles $m_{\#}^{(1)}$ and $m^{(2)}$. Two possibilities exist:

- If no Block STTD antenna diversity is applied to P-CCPCH, all the reference power of any physical channel providing the beacon function is allocated to $m^{(1)}$.
- If Block STTD antenna diversity is applied to P-CCPCH, for any physical channel providing the beacon function midambles $m^{(1)}$ and $m^{(2)}$ are each allocated half of the reference power. Midamble $m^{(1)}$ is used for the first antenna and $m^{(2)}$ is used for the diversity antenna. Block STTD encoding is used for the data in P-CCPCH, see [9]; for all other physical channels identical data sequences are transmitted on both antennas.

5.6.1 Midamble Allocation for DL Physical Channels

Physical channels providing the beacon function shall always use the reserved midambles [m^{\(1\)}](#) and [m^{\(2\)}](#), see 5.4. For all other DL physical channels the midamble allocation is signalled or given by default.

6 Mapping of transport channels to physical channels

This clause describes the way in which transport channels are mapped onto physical resources, see figure 187.

| Transport Channels | Physical Channels |
|--------------------|---|
| DCH | Dedicated Physical Channel (DPCH) |
| BCH | Primary Common Control Physical Channel (P-CCPCH) |
| FACH | Secondary Common Control Physical Channel (S-CCPCH) |
| PCH | |
| RACH | Physical Random Access Channel (PRACH) |
| ORACH* | |
| USCH | Physical Uplink Shared Channel (PUSCH) |
| DSCH | Physical Downlink Shared Channel (PDSCH) |
| | Paging Indicator Channel (PICH) |
| | Synchronisation Channel (SCH) |

Figure 17 **Figure 18:** Transport channel to physical channel mapping

6.1 Dedicated Transport Channels

A dedicated transport channel is mapped onto one or more physical channels. An interleaving period is associated with each allocation. The frame is subdivided into slots that are available for uplink and downlink information transfer. The mapping of transport blocks on physical channels is described in TS 25.222 ("multiplexing and channel coding").

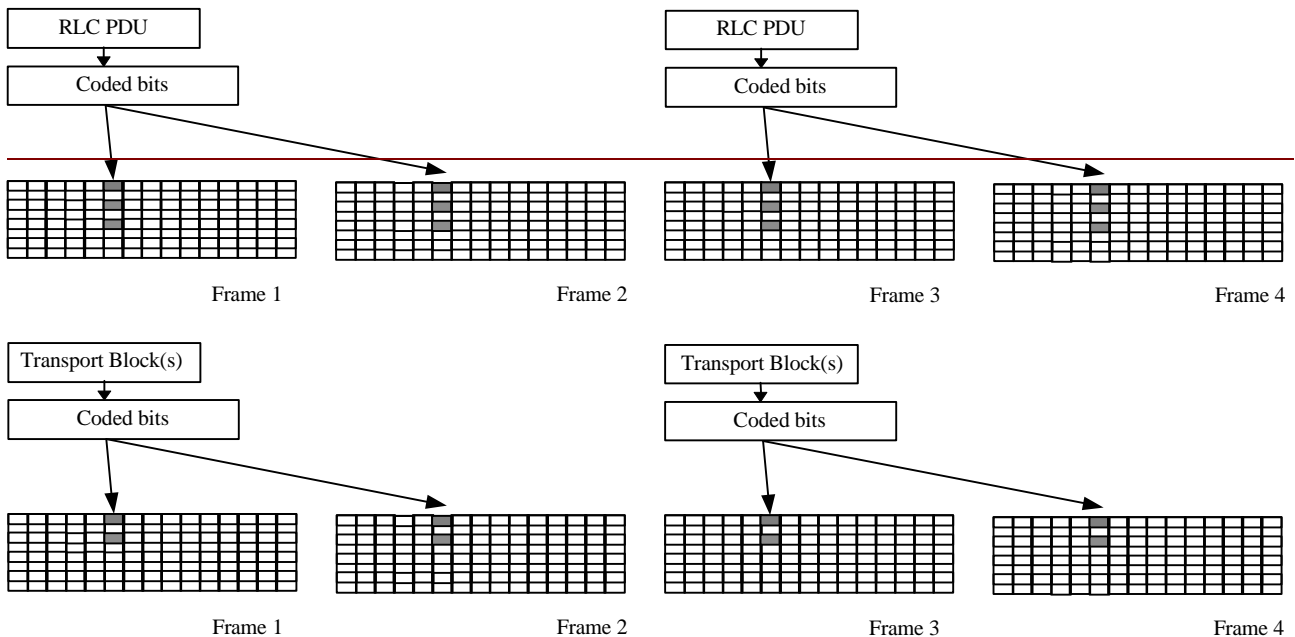

Figure 198: Mapping of **Transport Blocks** PDU onto the physical bearer

For NRT packet data services, shared channels (USCH and DSCH) can be used to allow efficient allocations for a short period of time.

6.2 Common Transport Channels

6.2.1 The Broadcast Channel (BCH)

The BCH is mapped onto the P-CCPCH. The secondary SCH indicates in which timeslot a mobile can find the P-CCPCH containing BCH. ~~If the broadcast information requires more resources than provided by the P-CCPCH, the BCH in P-CCPCH will comprise a pointer to additional S-CCPCH resources for FACH in which this additional broadcast information shall be sent.~~

6.2.2 The Paging Channel (PCH)

The PCH is mapped onto one or several S-CCPCHs so that capacity can be matched to requirements. The location of the PCH is indicated on the BCH. It is always transmitted at a reference power level.

To allow an efficient DRX, the PCH is divided into PCH blocks, each of which comprising N_{PCH} paging sub-channels. N_{PCH} is configured by higher layers. Each paging sub-channel is mapped onto 2 consecutive PCH frames within one PCH block. Layer 3 information to a particular UE is transmitted only in the paging sub-channel, that is assigned to the UE by higher layers, see [15]. The assignment of UEs to paging sub-channels is independent of the assignment of UEs to page indicators.

6.2.2.1 PCH/PICH Association

As depicted in figure 2019, a paging block consists of one PICH block and one PCH block. If a **pPaging i**Indicator in a certain PICH block is set to '1' it is an indication that UEs associated with this **pPaging i**Indicator shall read their corresponding paging sub-channel within the same paging block. The value $N_{GAP} > 0$ of frames between the end of the PICH block and the beginning of the PCH block is configured by higher layers.

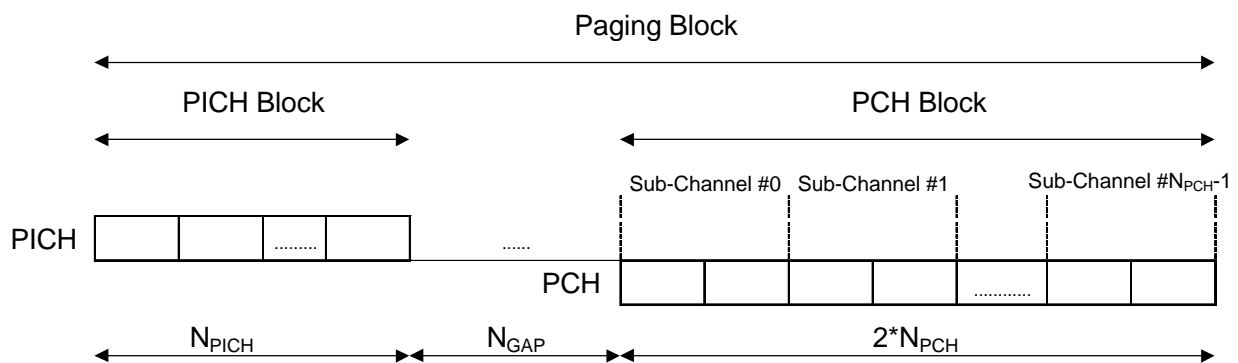

Figure 2019: Paging Sub-Channels and Association of PICH and PCH blocks

Annex B (Informative): CCPCH Multiframe Structure

In the following figures B.1 to B.3 some examples for Multiframe Structures on Primary and Secondary CCPCH are given. The figures show the placement of Common Transport Channels on the Common Control Physical Channels. Additional S-CCPCH capacity can be allocated on other codes and timeslots of course, e.g. FACH capacity is related to overall cell capacity and can be configured according to the actual needs. Channel capacities in the annex are derived using bursts with long midambles (Burst format 1). Every TrCH-box in the figures is assumed to be valid for two frames (see row 'Frame #'), i.e. the transport channels in CCPCHs have an interleaving time of 20msec.

The actual CCPCH Multiframe Scheme used in the cell is described and broadcast on BCH. Thus the system information structure has its roots in this particular transport channel and allocations of other Common Channels can be handled this way, i.e. by pointing from BCH.

| | | | | | | | | | | | | | | | | | | | | | | | | | | | | | | | | | | | | | | |
|---------------------------------|-----|-----|-----|-----|----------------------------------|-------|-------|-------|-------|--------------|-------|-------|-------|-------|----------------|-------|-------|-------|-------|----------------|-------|-------|-------|-------|-------|-------|-------|-------|-------|-------|-------|-------|-------|-------|-------|-------|--|--|
| Frame # | 0-1 | 2-3 | 4-5 | 6-7 | 8-9 | 10-11 | 12-13 | 14-15 | 16-17 | 18-19 | 20-21 | 22-23 | 24-25 | 26-27 | 28-29 | 30-31 | 32-33 | 34-35 | 36-37 | 38-39 | 40-41 | 42-43 | 44-45 | 46-47 | 48-49 | 50-51 | 52-53 | 54-55 | 56-57 | 58-59 | 60-61 | 62-63 | 64-65 | 66-67 | 68-69 | 70-71 | | |
| CCPCHs in TS k, Code 0 | | | | | | | | | | | | | | | | | | | | | | | | | | | | | | | | | | | | | | |
| CCPCHs in TS k+8, Co 0 | | | | | | | | | | | | | | | | | | | | | | | | | | | | | | | | | | | | | | |
| BCH transporting BCCH 2,71 kbps | | | | | FACH transporting BCCH 2,71 kbps | | | | | PCH 13,5kbps | | | | | PICH 2,71 kbps | | | | | FACH 27,1 kbps | | | | | | | | | | | | | | | | | | |

Figure B.1: Example for a multiframe structure for CCPCHs that is repeated every 72th frame

| | | | | | | | | | | | | | | | | | | | | | | | | | | | | | | | | | | | | | | |
|---------------------------------|-----|-----|-----|-----|----------------------------------|-------|-------|-------|-------|--------------|-------|-------|-------|-------|----------------|-------|-------|-------|-------|----------------|-------|-------|-------|-------|-------|-------|-------|-------|-------|-------|-------|-------|-------|-------|-------|-------|--|--|
| Frame # | 0-1 | 2-3 | 4-5 | 6-7 | 8-9 | 10-11 | 12-13 | 14-15 | 16-17 | 18-19 | 20-21 | 22-23 | 24-25 | 26-27 | 28-29 | 30-31 | 32-33 | 34-35 | 36-37 | 38-39 | 40-41 | 42-43 | 44-45 | 46-47 | 48-49 | 50-51 | 52-53 | 54-55 | 56-57 | 58-59 | 60-61 | 62-63 | 64-65 | 66-67 | 68-69 | 70-71 | | |
| CCPCHs in TS k, Code 0 | | | | | | | | | | | | | | | | | | | | | | | | | | | | | | | | | | | | | | |
| CCPCHs in TS k, Code n | | | | | | | | | | | | | | | | | | | | | | | | | | | | | | | | | | | | | | |
| CCPCHs in TS k+8, Co 0 | | | | | | | | | | | | | | | | | | | | | | | | | | | | | | | | | | | | | | |
| BCH transporting BCCH 2,71 kbps | | | | | FACH transporting BCCH 2,71 kbps | | | | | PCH 13,5kbps | | | | | PICH 2,71 kbps | | | | | FACH 51,5 kbps | | | | | | | | | | | | | | | | | | |

Figure B.2: Example for a multiframe structure for CCPCHs that is repeated every 72th frame, n=1...7

| | | | | | | | | | | | | | | | | | | | | | | | | | | | | | | | | | | | | | | |
|---------------------------------|-----|-----|-----|-----|-----------------------------------|-------|-------|-------|-------|--------------|-------|-------|-------|-------|----------------|-------|-------|-------|-------|----------------|-------|-------|-------|-------|-------|-------|-------|-------|-------|-------|-------|-------|-------|-------|-------|-------|--|--|
| Frame # | 0-1 | 2-3 | 4-5 | 6-7 | 8-9 | 10-11 | 12-13 | 14-15 | 16-17 | 18-19 | 20-21 | 22-23 | 24-25 | 26-27 | 28-29 | 30-31 | 32-33 | 34-35 | 36-37 | 38-39 | 40-41 | 42-43 | 44-45 | 46-47 | 48-49 | 50-51 | 52-53 | 54-55 | 56-57 | 58-59 | 60-61 | 62-63 | 64-65 | 66-67 | 68-69 | 70-71 | | |
| CCPCHs in TS k, Code 0 | | | | | | | | | | | | | | | | | | | | | | | | | | | | | | | | | | | | | | |
| CCPCHs in TS k+8, Co 0 | | | | | | | | | | | | | | | | | | | | | | | | | | | | | | | | | | | | | | |
| BCH transporting BCCH 2,71 kbps | | | | | FACH transporting BCCH 1,355 kbps | | | | | PCH 13,5kbps | | | | | PICH 2,71 kbps | | | | | FACH 28,5 kbps | | | | | | | | | | | | | | | | | | |

Figure B.3: Example for a multiframe structure for CCPCHs that is repeated every 72th frame

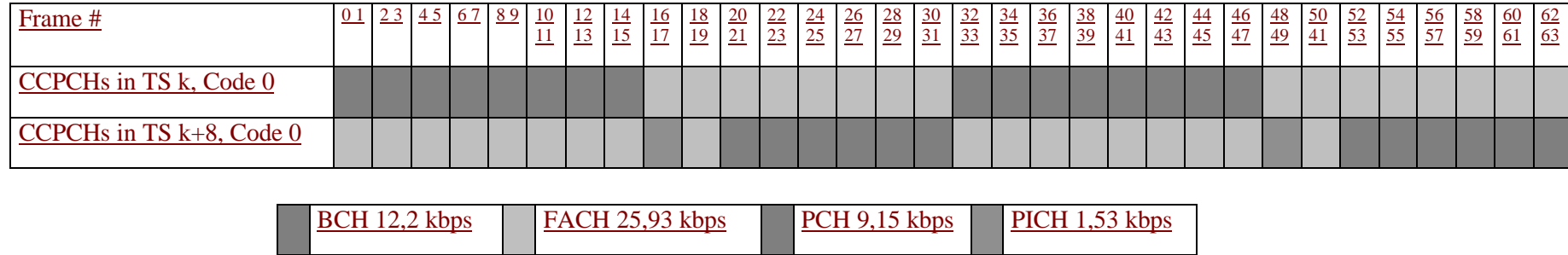

Figure B.1: Example for a multiframe structure for CCPCHs and PICH that is repeated every 64th frame

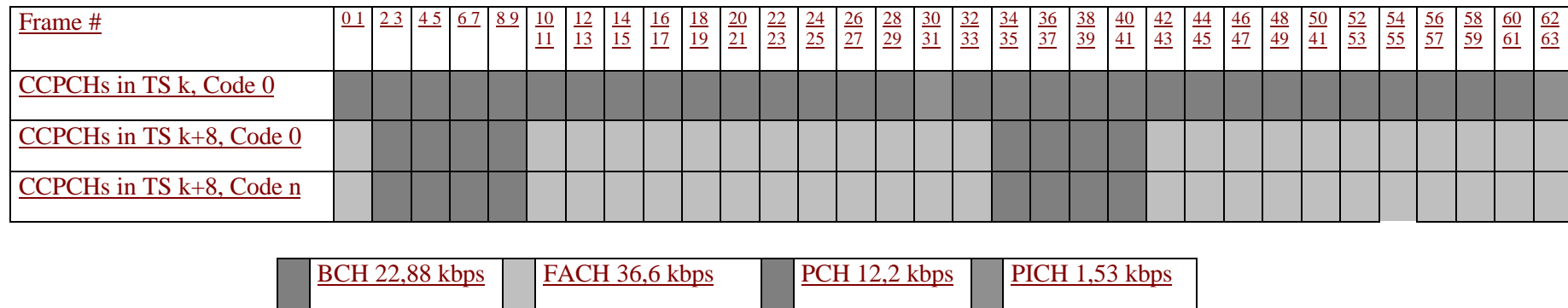

Figure B.2: Example for a multiframe structure for CCPCHs and PICH that is repeated every 64th frame, n=1...7

