

**Agenda item:** AH99

**Source:** Ericsson

**Title:** CR 25.212-088r1: Clarifications to TS 25.212

**Document for:** Decision

---

This CR proposes some smaller clarifications to TS 25.212 as follows:

- 4.2.7 Editorial change: Remove the underlined style of  $Np_{i,l}^{TTI,m}$ .
- 4.2.7.2.1.1: Correction of the section title. Compressed mode by higher layer scheduling is only defined for flexible positions of TrCHs.
- 4.2.9.2: Change the sentence about 2<sup>nd</sup> DTX insertion for compressed frames using puncturing and fixed positions. There is no need to insert – due to compressed mode – 2<sup>nd</sup> DTX indication, since p-bits are used.
- 4.2.10: Remove index  $i$  from Physical channel segmentation description. Physical channel segmentation is done after TrCH multiplexing, so there is no need to use the index  $i$  which is normally indexing the TrCH number.
- 4.3.3 and 4.3.4: Clarify the order of TFCI encoding. LSBs should be depicted on the right hand side in the figures, as usually done in binary notations.

The proposed changes for TS 25.212 are contained in the attached CR.



## 4.2.7 Rate matching

Rate matching means that bits on a transport channel are repeated or punctured. Higher layers assign a rate-matching attribute for each transport channel. This attribute is semi-static and can only be changed through higher layer signalling. The rate-matching attribute is used when the number of bits to be repeated or punctured is calculated.

The number of bits on a transport channel can vary between different transmission time intervals. In the downlink the transmission is interrupted if the number of bits is lower than maximum. When the number of bits between different transmission time intervals in uplink is changed, bits are repeated or punctured to ensure that the total bit rate after TrCH multiplexing is identical to the total channel bit rate of the allocated dedicated physical channels.

If no bits are input to the rate matching for all TrCHs within a CCTrCH, the rate matching shall output no bits for all TrCHs within the CCTrCH and no uplink DPDCH will be selected in the case of uplink rate matching.

### Notation used in subclause 4.2.7 and subclauses:

$N_{i,j}$ : For uplink: Number of bits in a radio frame before rate matching on TrCH  $i$  with transport format combination  $j$ .

For downlink: An intermediate calculation variable (not an integer but a multiple of 1/8).

$N_{i,l}^{TTI}$ : Number of bits in a transmission time interval before rate matching on TrCH  $i$  with transport format  $l$ .  
Used in downlink only.

$\Delta N_{i,j}$ : For uplink: If positive - number of bits that should be repeated in each radio frame on TrCH  $i$  with transport format combination  $j$ .

If negative - number of bits that should be punctured in each radio frame on TrCH  $i$  with transport format combination  $j$ .

For downlink : An intermediate calculation variable (not an integer but a multiple of 1/8).

$\Delta N_{i,l}^{TTI}$ : If positive - number of bits to be repeated in each transmission time interval on TrCH  $i$  with transport format  $l$ .

If negative - number of bits to be punctured in each transmission time interval on TrCH  $i$  with transport format  $l$ .

Used in downlink only.

$Np_{i,l}^{TTI,m}$ ,  $m=0$  to  $(F_{max}/F_i) - 1$ : Positive or null: number of bits to be removed in TTI number  $m$  within the largest TTI, to create the required gaps in the compressed radio frames of this TTI, in case of compressed mode by puncturing, for TrCH  $i$  with transport format  $l$ . In case of fixed positions and compressed mode by puncturing, this value is noted  $Np_{i,max}^{TTI,m}$  since it is calculated for all TrCH with their maximum number of bits; thus it is the same for all TFCs

Used in downlink only.

$Np_{i,l}^n$ ,  $n=0$  to  $F_{max}-1$ : Positive or null: number of bits, in radio frame number  $n$  within the largest TTI, corresponding to the gap for compressed mode in this radio frame, for TrCH  $i$  with transport format  $l$ . The value will be null for the radio frames not overlapping with a transmission gap. In case of fixed positions and compressed mode by puncturing, this value is noted  $Np_{i,max}^n$  since it is calculated for all TrCHs with their maximum number of bits; thus it is the same for all TFCs

Used in downlink only.

$N_{TGL}[k]$ ,  $k=0$  to  $F_{max}-1$ : Positive or null: number of bits in each radio frame corresponding to the gap for compressed mode for the CCTrCH.

- $RM_i$ : Semi-static rate matching attribute for transport channel  $i$ .  $RM_i$  is provided by higher layers or takes a value as indicated in section 4.2.13.
- $PL$ : Puncturing limit for uplink. This value limits the amount of puncturing that can be applied in order to avoid multicode or to enable the use of a higher spreading factor. Signalled from higher layers.
- $N_{data,j}$ : Total number of bits that are available for the CCTrCH in a radio frame with transport format combination  $j$ .
- $I$ : Number of TrCHs in the CCTrCH.
- $Z_{i,j}$ : Intermediate calculation variable.
- $F_i$ : Number of radio frames in the transmission time interval of TrCH  $i$ .
- $F_{max}$ : Maximum number of radio frames in a transmission time interval used in the CCTrCH :

$$F_{max} = \max_{1 \leq i \leq I} F_i$$

- $n_i$ : Radio frame number in the transmission time interval of TrCH  $i$  ( $0 \leq n_i < F_i$ ).
- $q$ : Average puncturing or repetition distance (normalised to only show the remaining rate matching on top of an integer number of repetitions). Used in uplink only.
- $P1_F(n_i)$ : The column permutation function of the 1<sup>st</sup> interleaver,  $P1_F(x)$  is the original position of column with number  $x$  after permutation.  $P1$  is defined on table 3 of section 4.2.5.2 (note that the  $P1_F$  is self-inverse). Used for rate matching in uplink only.
- $S[n]$ : The shift of the puncturing or repetition pattern for radio frame  $n_i$  when  $n = P1_{F_i}(n_i)$ . Used in uplink only.
- $TF_i(j)$ : Transport format of TrCH  $i$  for the transport format combination  $j$ .
- $TFS(i)$ : The set of transport format indexes  $l$  for TrCH  $i$ .
- $TFCS$ : The set of transport format combination indexes  $j$ .
- $e_{ini}$ : Initial value of variable  $e$  in the rate matching pattern determination algorithm of subclause 4.2.7.5.
- $e_{plus}$ : Increment of variable  $e$  in the rate matching pattern determination algorithm of subclause 4.2.7.5.
- $e_{minus}$ : Decrement of variable  $e$  in the rate matching pattern determination algorithm of subclause 4.2.7.5.
- $b$ : Indicates systematic and parity bits
- $b=1$ : Systematic bit.  $x_k$  in subclause 4.2.3.2.1.
- $b=2$ : 1<sup>st</sup> parity bit (from the upper Turbo constituent encoder).  $z_k$  in subclause 4.2.3.2.1.
- $b=3$ : 2<sup>nd</sup> parity bit (from the lower Turbo constituent encoder).  $z'_k$  in subclause 4.2.3.2.1.

The \* (star) notation is used to replace an index  $x$  when the indexed variable  $X_x$  does not depend on the index  $x$ . In the left wing of an assignment the meaning is that " $X_* = Y$ " is equivalent to "for all  $x$  do  $X_x = Y$ ". In the right wing of an assignment, the meaning is that " $Y = X_*$ " is equivalent to "take any  $x$  and do  $Y = X_x$ ".

The following relations, defined for all TFC  $j$ , are used when calculating the rate matching parameters:

$$Z_{0,j} = 0$$

$$Z_{i,j} = \left[ \frac{\left( \left( \sum_{m=1}^i RM_m \times N_{m,j} \right) \times N_{data,j} \right)}{\sum_{m=1}^I RM_m \times N_{m,j}} \right] \text{ for all } i = 1 \dots I \quad (1)$$

$$\Delta N_{i,j} = Z_{i,j} - Z_{i-1,j} - N_{i,j} \text{ for all } i = 1 \dots I$$

4.2.7.2.1.1 Calculation of  $\Delta N_{i,max}$  for normal mode and compressed mode by ~~higher-layer scheduling and~~ spreading factor reduction

First an intermediate calculation variable  $N_{i,*}$  is calculated for all transport channels  $i$  by the following formula:

$$N_{i,*} = \frac{1}{F_i} \times \left( \max_{l \in TFS(i)} N_{i,l}^{TTI} \right)$$

In order to compute the  $\Delta N_{i,l}^{TTI}$  parameters for all TrCH  $i$  and all TF  $l$ , we first compute an intermediate parameter  $\Delta N_{i,max}$  by the following formula, where  $\Delta N_{i,*}$  is derived from  $N_{i,*}$  by the formula given at subclause 4.2.7:

$$\Delta N_{i,max} = F_i \times \Delta N_{i,*}$$

If  $\Delta N_{i,max} = 0$  then, for TrCH  $i$ , the output data of the rate matching is the same as the input data and the rate matching algorithm of subclause 4.2.7.5 does not need to be executed. In this case we have :

$$\forall l \in TFS(i) \Delta N_{i,l}^{TTI} = 0$$

If  $\Delta N_{i,max} \neq 0$  the parameters listed in subclauses 4.2.7.2.1.3 and 4.2.7.2.1.4 shall be used for determining  $e_{ini}$ ,  $e_{plus}$ , and  $e_{minus}$  and  $\Delta N_{i,l}^{TTI}$ .

#### 4.2.9.2 2<sup>nd</sup> insertion of DTX indication bits

The DTX indication bits inserted in this step shall be placed at the end of the radio frame. Note that the DTX will be distributed over all slots after 2<sup>nd</sup> interleaving.

The bits input to the DTX insertion block are denoted by  $s_1, s_2, s_3, \dots, s_S$ , where  $S$  is the number of bits from TrCH multiplexing. The number of PhCHs is denoted by  $P$  and the number of bits in one radio frame, including DTX indication bits, for each PhCH by  $R$ .

In normal mode  $R = \frac{N_{data,*}}{P} = 15 \times (N_{data1} + N_{data2})$ , where  $N_{data1}$  and  $N_{data2}$  are defined in [2].

For compressed mode,  $N'_{data,*}$  is defined as  $N'_{data,*} = P \times 15 \times (N'_{data1} + N'_{data2})$ .  $N'_{data1}$  and  $N'_{data2}$  are the number of bits in the data fields of the slot format used for the current compressed mode, i.e. slot format A or B as defined in [2] corresponding to the Spreading Factor and the number of transmitted slots in use.

In ~~ease of frames~~ compressed ~~mode~~ by puncturing and ~~when~~ fixed positions ~~are used~~, ~~no~~ DTX shall be inserted ~~until~~  ~~$N'_{data,*}$  bits~~, since the exact room for the gap is already reserved thanks to the earlier insertion of the p-bits. ~~Therefore R is defined as  $R = N'_{data,*} / P$ .~~

In ~~frames~~ compressed ~~mode~~ by higher layer scheduling, additional DTX with respect to normal mode shall be inserted if the transmission time reduction ~~by higher layer scheduling~~ does not exactly create a transmission gap of the desired *TGL*. The number of bits available to the CCTrCH in one radio frame in compressed mode by SF reduction and by

higher layer scheduling is denoted by  $N_{data,*}^{cm}$  and  $R = \frac{N_{data,*}^{cm}}{P}$ .

For the transmission time reduction by SF/2 method in compressed mode  $N_{data,*}^{cm} = \frac{N'_{data,*}}{2}$

For compressed mode by higher layer scheduling the exact value of  $N_{data,*}^{cm}$  is dependent on the *TGL* which is signalled from higher layers. It can be calculated as  $N_{data,*}^{cm} = N'_{data,*} - N_{TGL}$ .

$N_{TGL}$  is the number of bits that are located within the transmission gap and defined as:

$$N_{TGL} = \begin{cases} \frac{TGL}{15} \times N'_{data,*}, & \text{if } N_{first} + TGL \leq 15 \\ \frac{15 - N_{first}}{15} \times N'_{data,*}, & \text{in first frame if } N_{first} + TGL > 15 \\ \frac{TGL - (15 - N_{first})}{15} \times N'_{data,*}, & \text{in second frame if } N_{first} + TGL > 15 \end{cases}$$

$N_{first}$  and *TGL* are defined in subclause 4.4.

The bits output from the DTX insertion block are denoted by  $w_1, w_2, w_3, \dots, w_{(PR)}$ . Note that these bits are four valued in case of compressed mode by puncturing, and three valued otherwise. They are defined by the following relations:

$$w_k = s_k \quad k = 1, 2, 3, \dots, S$$

$$w_k = \mathbf{d} \quad k = S+1, S+2, S+3, \dots, P \times R$$

where DTX indication bits are denoted by  $\mathbf{d}$ . Here  $s_k \in \{0, 1, p\}$  and  $\mathbf{d} \notin \{0, 1\}$ .

## 4.2.10 Physical channel segmentation

When more than one PhCH is used, physical channel segmentation divides the bits among the different PhCHs. The bits input to the physical channel segmentation are denoted by  $x_1, x_2, x_3, \dots, x_X$ , where  $X$  is the number of bits input to the physical channel segmentation block. The number of PhCHs is denoted by  $P$ .

The bits after physical channel segmentation are denoted  $u_{p1}, u_{p2}, u_{p3}, \dots, u_{pU}$ , where  $p$  is PhCH number and  $U$  is the number of bits in one radio frame for each PhCH, i.e.  $U = (X - N_{TGL}) / P$  for compressed mode by puncturing, and  $U = \frac{X}{P}$  otherwise. The relation between  $x_k$  and  $u_{pk}$  is given below.

For all modes, some bits of the input flow are mapped to each code until the number of bits on the code is  $U$ . For modes other than compressed mode by puncturing, all bits of the input flow are taken to be mapped to the codes. For compressed mode by puncturing, only the bits of the input flow not corresponding to bits  $p$  are taken to be mapped to the codes, each bit  $p$  is removed to ensure creation the gap required by the compressed mode, as described below.

Bits on first PhCH after physical channel segmentation:

$$u_{1,k} = x_{i,f(k)} \quad k = 1, 2, \dots, U$$

Bits on second PhCH after physical channel segmentation:

$$u_{2,k} = x_{i,f(k+U)} \quad k = 1, 2, \dots, U$$

...

Bits on the  $P^{\text{th}}$  PhCH after physical channel segmentation:

$$u_{P,k} = x_{i,f(k+(P-1) \times U)} \quad k = 1, 2, \dots, U$$

where  $f$  is such that :

- for modes other than compressed mode by puncturing,  $x_{i,f(k)} = x_{i,k}$ , i.e.  $f(k) = k$ , for all  $k$ .
- for compressed mode by puncturing, bit  $u_{1,1}$  corresponds to the bit  $x_{i,k}$  with smallest index  $k$  when the bits  $p$  are not counted, bit  $u_{1,2}$  corresponds to the bit  $x_{i,k}$  with second smallest index  $k$  when the bits  $p$  are not counted, and so on for bits  $u_{1,3}, \dots, u_{1,U}, u_{2,1}, u_{2,2}, \dots, u_{2,U}, \dots, u_{P,1}, u_{P,2}, \dots, u_{P,U}$ .



### 4.3.3 Coding of Transport-Format-Combination Indicator (TFCI)

The TFCI is encoded using a (32, 10) sub-code of the second order Reed-Muller code. The coding procedure is as shown in figure 9.

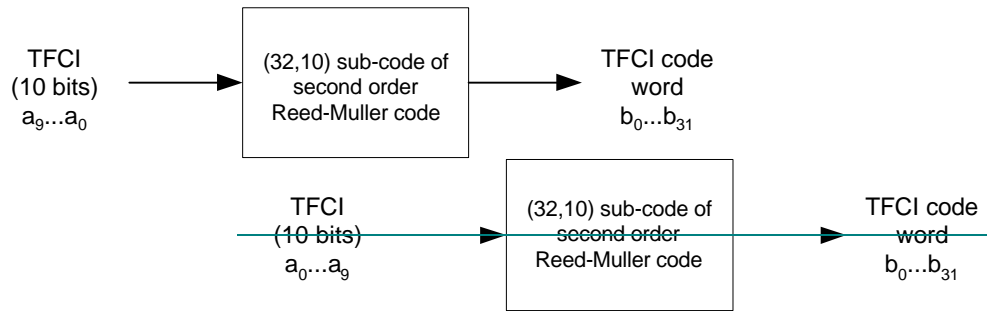

	$M_{i,0}$	$i_{i,1}$	$M$	$M_{i,3}$	$i_{i,4}$	$M$	$M_{i,6}$	$i_{i,7}$	$M$	$M_{i,9}$
0	1		0	0		1	0		0	0
	0	1		0	0		1	0		0
2		1	0		0	1		0	0	
3	0		1	0		1	1		1	1
	1	0		0	0		0	0		1
5		1	1		0	1		0	1	
6	1		1	0		1	0		0	0
	0	0		1	0		0	1		0
8		0	0		0	1		1	1	
9	0		0	1		1	1		1	1
	1	1		1	0		0	0		1
11		0	1		0	1		1	1	
12	1		1	1		1	0		0	1
	0	1		1	0		1	0		1
14		1	1		0	1		1	1	
15	1		0	0		1	1		0	0
	0	1		0	1		1	1		1
17		1	0		1	1		0	1	
18	0		1	0		1	0		1	1
	1	0		0	1		0	1		1
20		1	1		1	1		0	1	
21	1		1	0		1	0		1	1
	0	0		1	1		0	1		0
23		0	0		1	1		1	0	
24	0		0	1		1	1		1	0
	1	1		1	1		1	0		1
26		0	1		1	1		0	1	
27	1		1	1		1	1		0	0
	0	1		1	1		1	1	1	
29	1		1	1		1	1		1	1
	0	0		0	0		0	0		0
31		0	0		1	1		0	0	

Let's define the TFCI as  $a_0, a_1, a_2, a_3, a_4, a_5, a_6, a_7, a_8, a_9$  ( $a_0$  is LSB and  $a_9$  is MSB). The information bits shall correspond to the TFC index (expressed in unsigned binary form) defined by the RRC layer to reference the TFC of the CCTrCH in the associated DPCH radio frame.

The output code word bits  $b_i$  are given by:

$$b_i = \sum_{n=0}^{M-1} (a_n \times M^n) \quad 2$$

The bits are denoted by  $b_k$   $k = 0, 1, \dots, 31$ .

normal mode and 16 encoded TFCI bits per slot in compressed mode. Mapping of repeated bits to slots is explained in 4.3.5.

### Operation of Transport-format-combination indicator (TFCI) in Mode

relevant for TFCI activity indication is not transmitted from every slot. The use of such a functionality shall be

TFCI in figure 10.

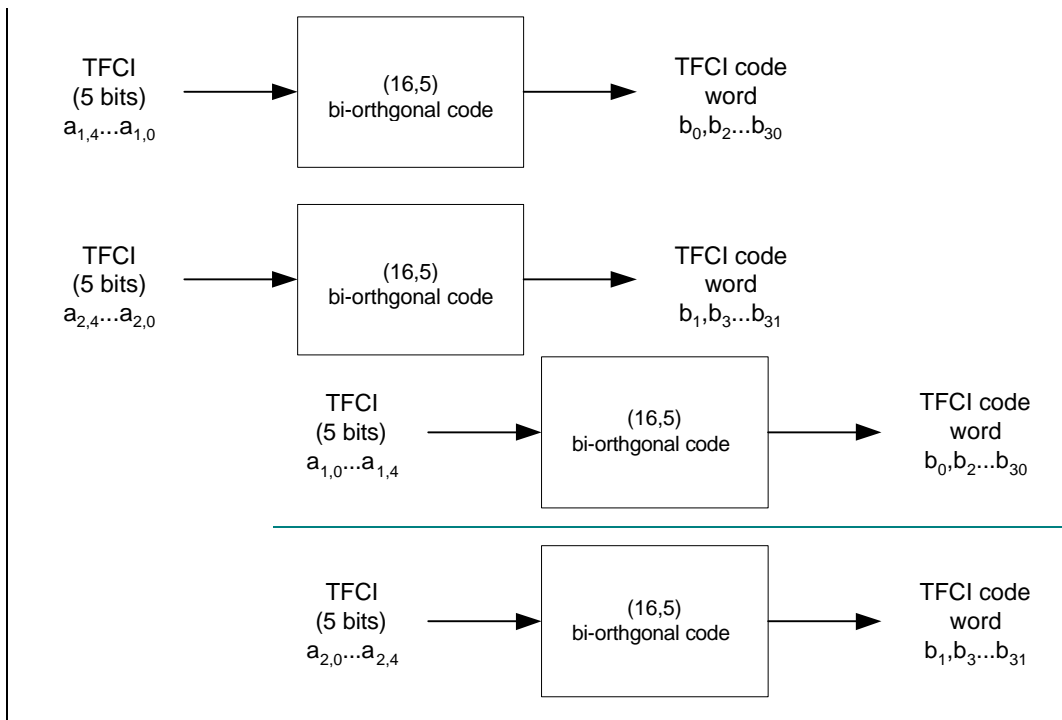

**Figure 10: Channel coding of split mode TFCI information bits**

The code words of the (16,5) bi-orthogonal code are linear combinations of 5 basis sequences as defined in table 8.

**8: sequences for (16,5) TFCI code**

	$M_{i,0}$	$i_{i,1}$	$M$	$M_{i,3}$	$i_{i,4}$
0	1	0	0	0	1
1	0	1	0	0	1
2	1	1	0	0	1
3	0	0	1	0	1
4	1	0	1	0	1
5	0	1	1	0	1
6	1	1	1	0	1
7	0	0	0	1	1
8	1	0	0	1	1
9	0	1	0	1	1
10	1	1	0	1	1
11	0	0	1	1	1
12	1	0	1	1	1
13	0	1	1	1	1
14	1	1	1	1	1
15	0	0	0	0	1

Let's define a first set of TFCI information bits as  $a_{1,0}, a_{1,1}, a_{1,2}, a_{1,3}, a_{1,4}$  ( $a_{1,0}$  is LSB and  $a_{1,4}$  is MSB). This set of TFCI information bits shall correspond to the TFC index (expressed in unsigned binary form) defined by the RRC layer to reference the TFC of the DCH CCTrCH in the associated DPCH radio frame.

Let's define a second set of TFCI information bits as  $a_{2,0}, a_{2,1}, a_{2,2}, a_{2,3}, a_{2,4}$  ( $a_{2,0}$  is LSB and  $a_{2,4}$  is MSB). This set of TFCI information bits shall correspond to the TFC index (expressed in unsigned binary form) defined by the RRC layer to reference the TFC of the associated DSCH CCTrCH in the corresponding PDSCH radio frame.

The output code word bits  $b_k$  are given by:

$$b_{2i} = \sum_{n=0}^4 (a_{1,n} \times M_{i,n}) \bmod 2; \quad b_{2i+1} = \sum_{n=0}^4 (a_{2,n} \times M_{i,n}) \bmod 2$$

where  $i = 0, \dots, 15$ .

The output bits are denoted by  $b_k, k = 0, 1, 2, \dots, 31$ .