

**Source:** Siemens AG  
**Title:** TDD related changes for TR25.944  
**Document for:** Approval

---

## **Introduction**

In RAN#7, it was endorsed to change TR25.944 to align with “Typical radio parameter sets” from ISG (ISG document). According to the endorsement and the changes, made in the FDD part of the document, this document clarifies the changes in the TDD part of the TR. Error corrections are clarified in this document, also. The detailed revisions are clarified in the CR.

## **Overview of the changes in the TDD Part of the TR25.944**

### Section 4.2.1.2 Example for PCH and FACH

- Transport block size, Transport block set size, and coding are changed according to the ISG document.
- Number of TrBks for transport block concatenation is clarified in the figure.
- Errors concerning the number of bits in case of no transport block are corrected.
- Stand-alone mapping of PCH/FACH removed

### Section 4.2.1.4.1.1 Example for 3.4 kbps data

- Data rate is changed to 3.4 kbps according to the ISG document.
- Transport block size and Transport block set size are changed according to the ISG document.
- Number of TrBks for transport block concatenation is clarified in the figure.

### Section 4.2.1.4.1.2 Example for 12.2 kbps data

- Transport block size and Transport block set size are changed according to the ISG document.
- CRC parity bit attachment for 0 bit transport block is clarified in table 4.
- Numbers for TrCHs are changed from #1, 2, and 3 to #a, b and c. And Numbers after radio frame segmentation are changed from #1a, 1b, 2a, 2b, 3a and 3c to #1a, 2a, 1b, 2b, 1c and 2c in order to align with other figures, i.e. integer numbers after radio frame segmentation show frame number in a TTI.

### Section 4.2.1.4.1.3 Example for 28.8/57.6 kbps data

- New section. This example is corresponding to streaming 28.8/57.6 kbps RABs

### Section 4.2.1.4.1.4 Example for 64/128/144 kbps packet data, and Section 4.2.1.4.1.5 Example for 384 kbps packet data

- Transport block size, Transport block set size and TTI are changed according to the ISG document.
- Number of TrBks for transport block concatenation is clarified in the figure.
- 144 kbps packet data is added according to the ISG document.
- 384 kbps packet data is moved to the new section 4.2.1.4.1.5 since code block segmentation is applied only to 384 kbps packet data.
- Errors concerning the number of bits in case of no transport block are corrected.

### Section 4.2.1.4.2.1 Example for Stand-alone mapping of 3.4 kbps data

- Data rate is changed to 3.4 kbps according to the ISG document.

### Section 4.2.1.4.2.2 Example for multiplexing of 12.2 kbps data and 3.4 kbps data

- Data rate is changed to 3.4 kbps according to the ISG document.

### Section 4.2.1.4.2.3 Example for multiplexing of 28.8/57.6 kbps data and 3.4 kbps data

- New section. This example is corresponding to multiplexing of streaming 28.8/57.6 kbps RABs and DCCH.

#### Section 4.2.1.4.2.4 Example for multiplexing of 64/128/144/384 kbps packet data and 3.4 kbps data

- 144 kbps packet data is added according to the ISG document.
- Data rate is changed to 3.4 kbps according to the ISG document.
- TTI for packet is changed from 10 ms to 20 ms according to the ISG document.
- $N_{data1}$  and  $N_{data2}$  in the table are corrected.

#### Section 4.2.1.4.2.4 Example for multiplexing of 64 kbps data and 3.4 kbps data

- Data rate is changed to 3.4 kbps according to the ISG document.

#### Section 4.2.1.4.2.5 Example for multiplexing of 12.2 kbps data , 64/128/144/384 kbps packet data and 3.4 kbps data

- New section. This example is corresponding to multiplexing of AMR speech, 64/128/144/384 kbps packet and DCCH.

#### Section 4.2.2.1 Example for RACH

- Table for Transport block size, CRC, etc are added according to the ISG document.
- Transport block multiplexing is deleted according to the ISG document.
- Code block segmentation is deleted according to the ISG document.

#### Section 4.2.2.2.1 Example for Stand-alone mapping of 3.4 kbps data

- Data rate is changed to 3.4 kbps according to the ISG document.

#### Section 4.2.2.2.2 Example for multiplexing of 12.2 kbps data and 3.4 kbps data

- Data rate is changed to 3.4 kbps according to the ISG document.

#### Section 4.2.2.2.3 Example for multiplexing of 28.8/57.6 kbps data and 3.4 kbps data

- New section. This example is corresponding to multiplexing of streaming 28.8/57.6 kbps RABs and DCCH.

#### Section 4.2.2.2.4 Example for multiplexing of 64/128/144/384 kbps packet data and 3.4 kbps data

- 144 kbps packet data is added according to the ISG document.
- Data rate is changed to 3.4 kbps according to the ISG document.
- TTI for packet is changed from 10 ms to 20 ms according to the ISG document.

#### Section 4.2.2.2.5 Example for multiplexing of 64 kbps data and 3.4 kbps data

- Data rate is changed to 3.4 kbps according to the ISG document.



## 4.2 TDD mode

### 4.2.1 Downlink

#### 4.2.1.1 BCH

**Table 16: Parameters for BCH**

Transport block size	246 bits
CRC	16 bits
Coding	CC, coding rate = 1/2
TTI	20 ms
Midamble	512 chips
Codes and time slots	SF = 16 x 1 x 1 time slot
TFCI	0 bit
TPC	0 bit

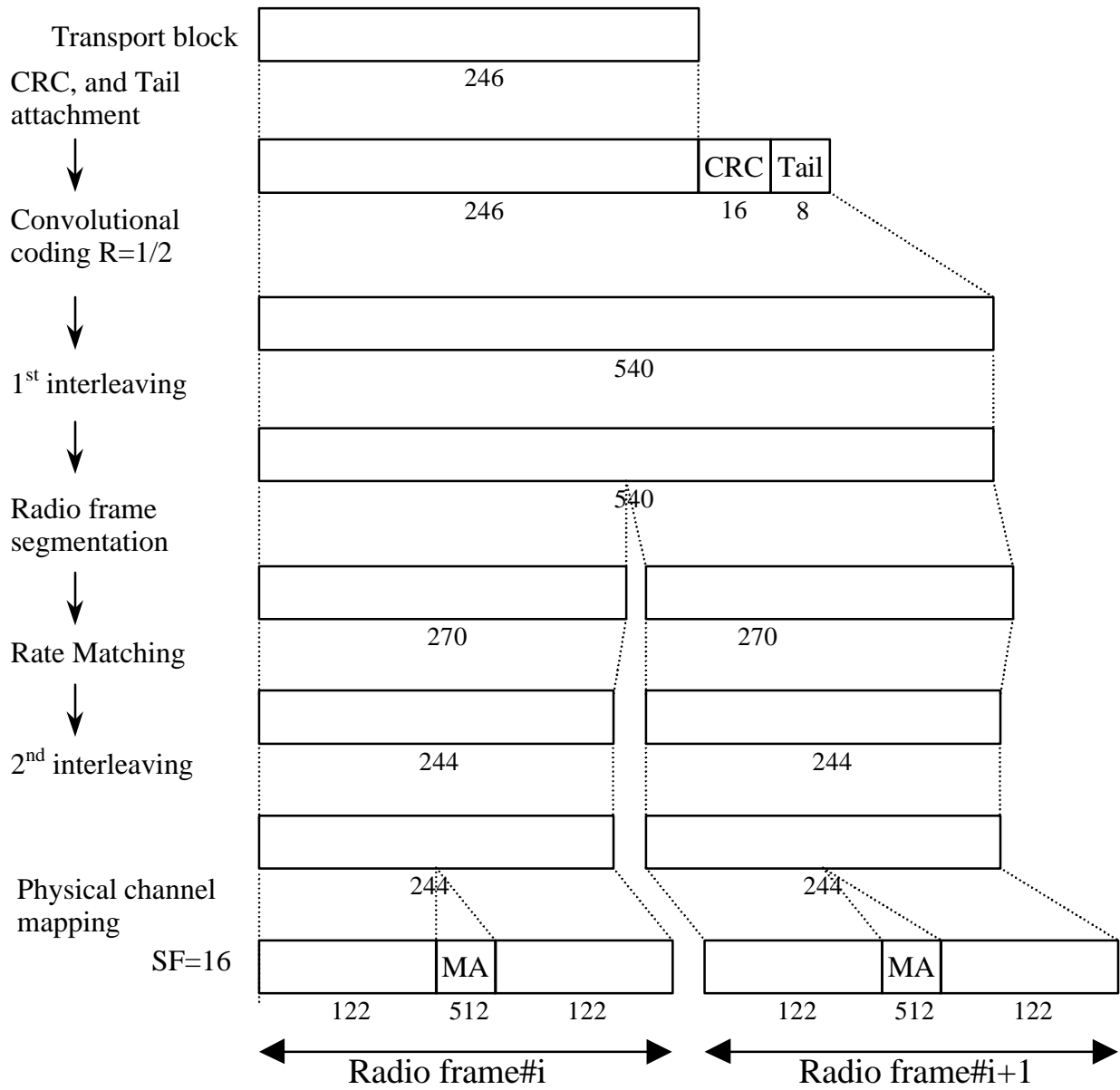
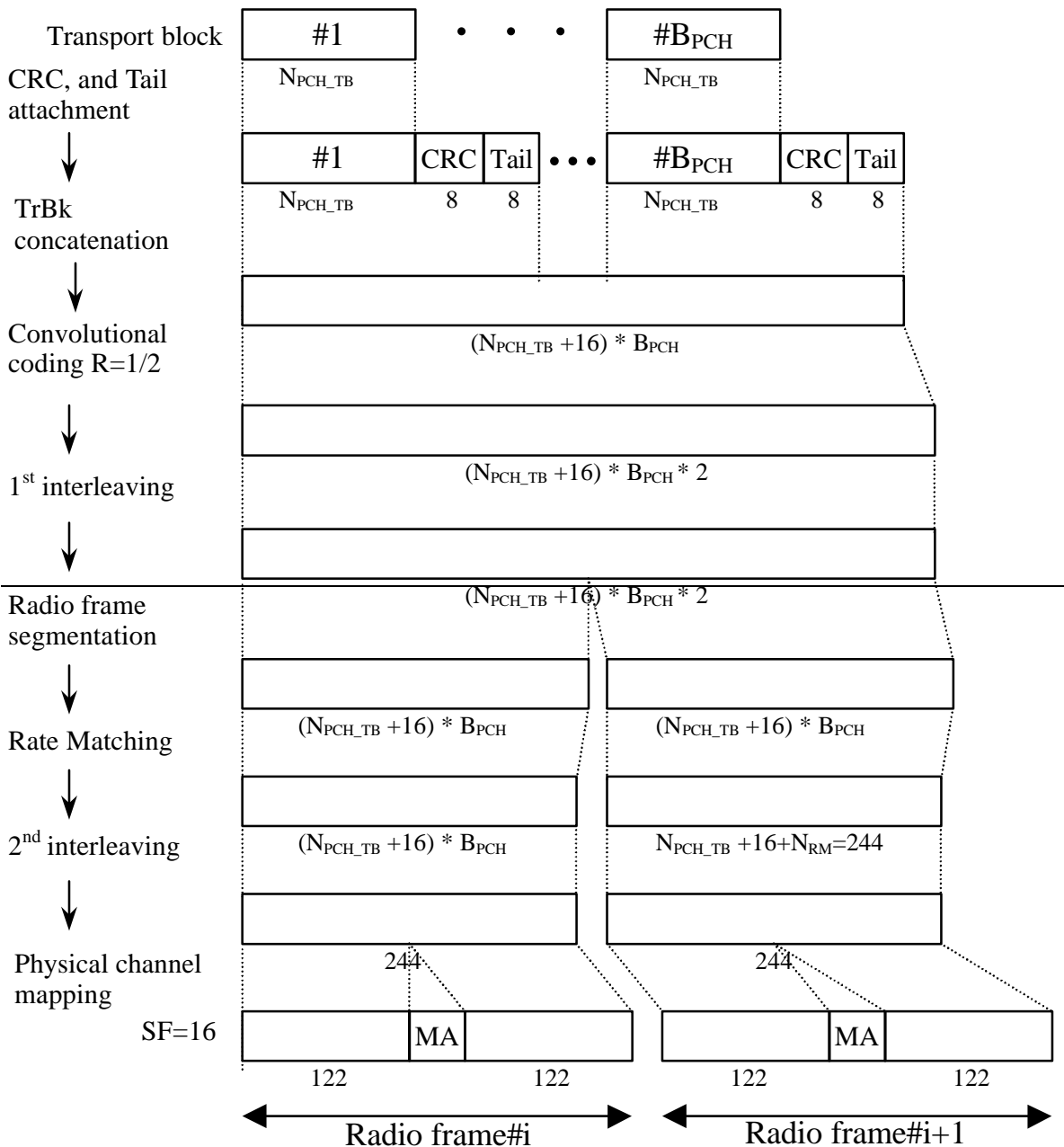

Figure 20: Channel coding for BCH

## 4.2.1.2 Example for PCH and FACH

Table 17: Parameters for PCH and FACH

Transport block size	PCH	$N_{PCH}=64$ or $240$ bits
	FACH1	360 bits
	FACH2	168 bits
Transport block set size	PCH	$64 \cdot B_{PCH}$ or $240 \cdot B_{PCH}$ bits ( $B_{PCH}=0,1$ )
	FACH1	$360 \cdot B_{FACH1}$ bits ( $B_{FACH1}=0,1$ )
	FACH2	$168 \cdot B_{FACH2}$ bits ( $B_{FACH2}=0,1,2,3$ )
GRC		8 bits
Coding	PCH, FACH2	CC, coding rate = 1/2
	FACH1	TC
TTI		20-10 ms
Midamble		512 chips
Codes and time slots		SF = 16 x 1 x 1 time slot
TFCI		0-16 bit
TPC		0 bit



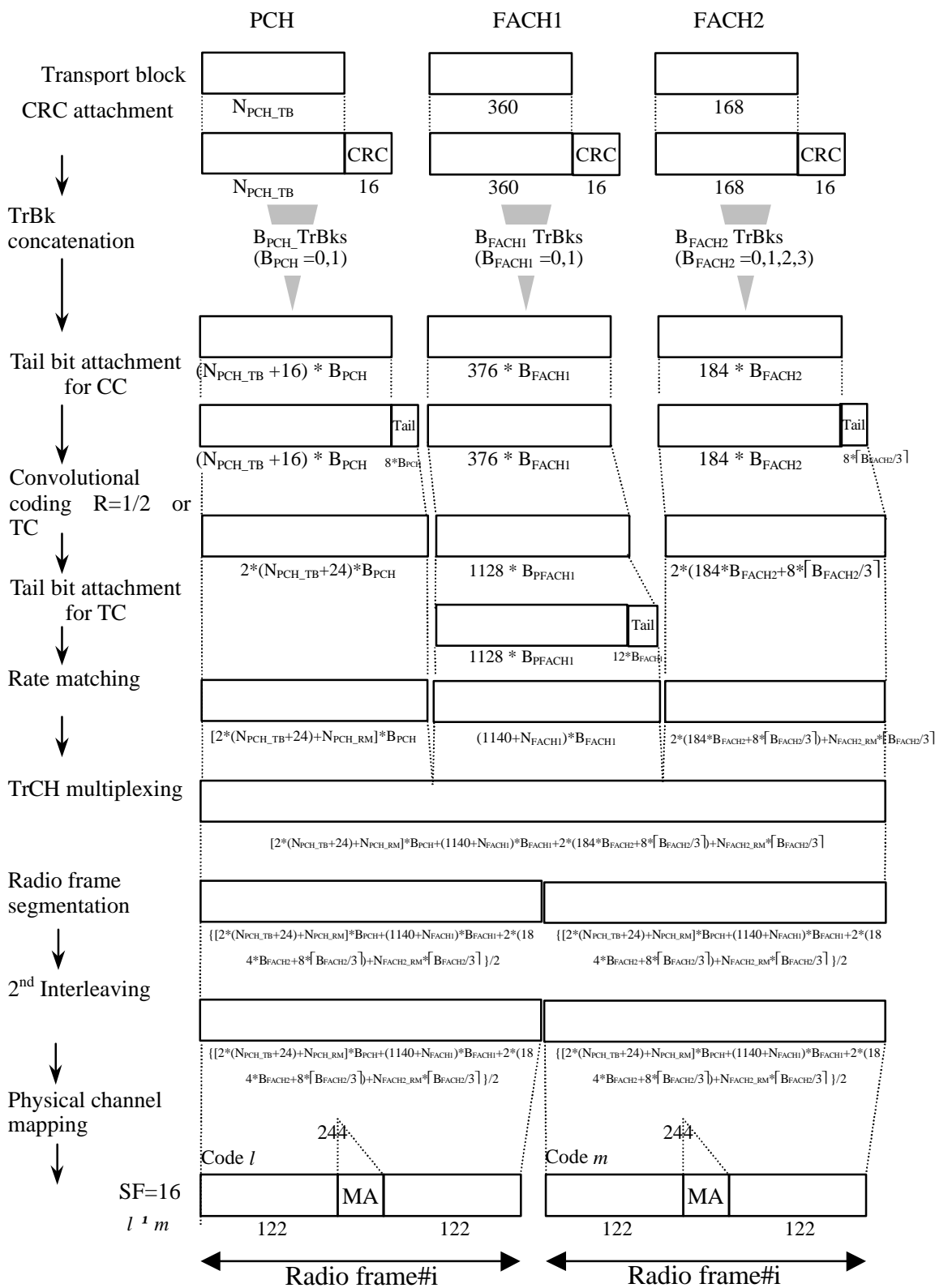

Figure 21: Channel coding and multiplexing example for PCH and FACH



4.2.1.3 Example for FACH

**Table 18: Parameters for FACH**

CRC	8-bits
Coding	CC, coding rate = 1/2
T <sub>T</sub>	20 ms
Midamble	512 chips
Codes and time slots	SF = 16 x 1 x 1 time slot
TFGI	0-bit
TPC	0-bit

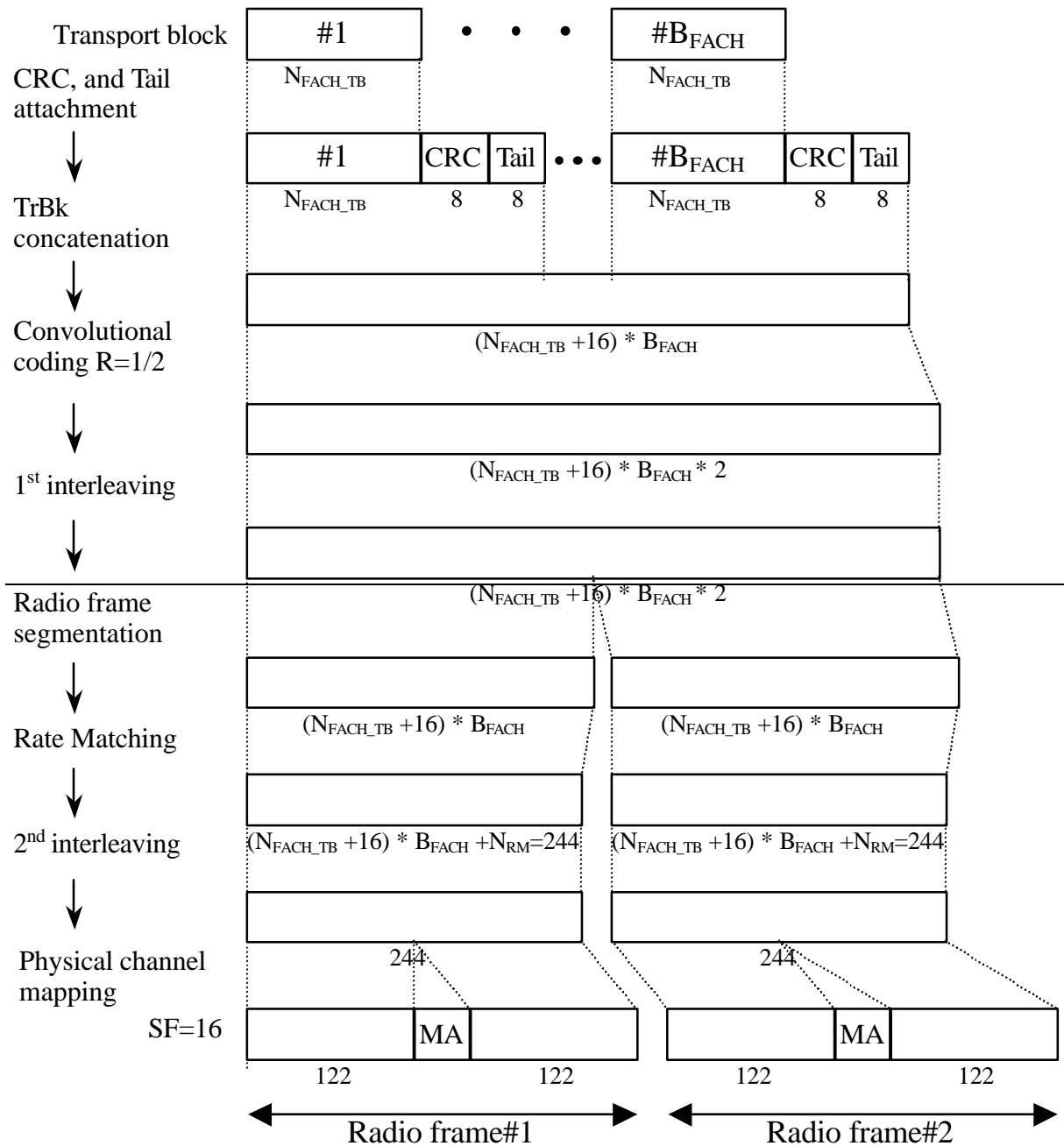

**Figure 22: Channel coding and multiplexing example for FACH**

4.2.1.4 Example for DCH

4.2.1.4.1 DCH-> Radio frame segmentation

4.2.1.4.1.1 Example for 23.4 kbps data

NOTE: This example can be applied to DCCH.

NOTE: In this example, it is assumed that maximum data rate of RLC payload is 3.4kbps, and that MAC and RLC overhead in a transport block is 12 bits.

Table 19: Parameter examples for 23.4 kbps data

Transport block size	96-148 bits
Transport block set size	96-148*B bits (B=0,1)
CRC	16 bits
Coding	CC, coding rate = 1/3
TTI	40 ms

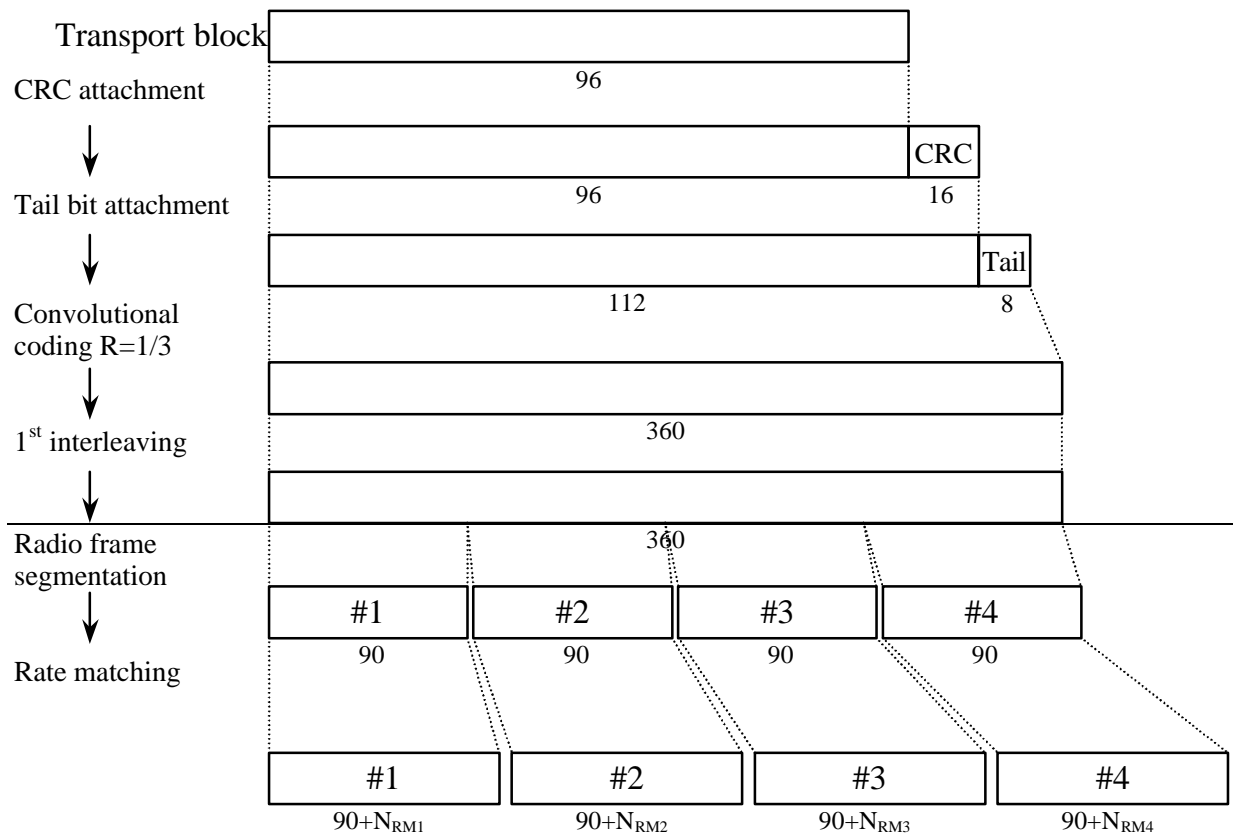

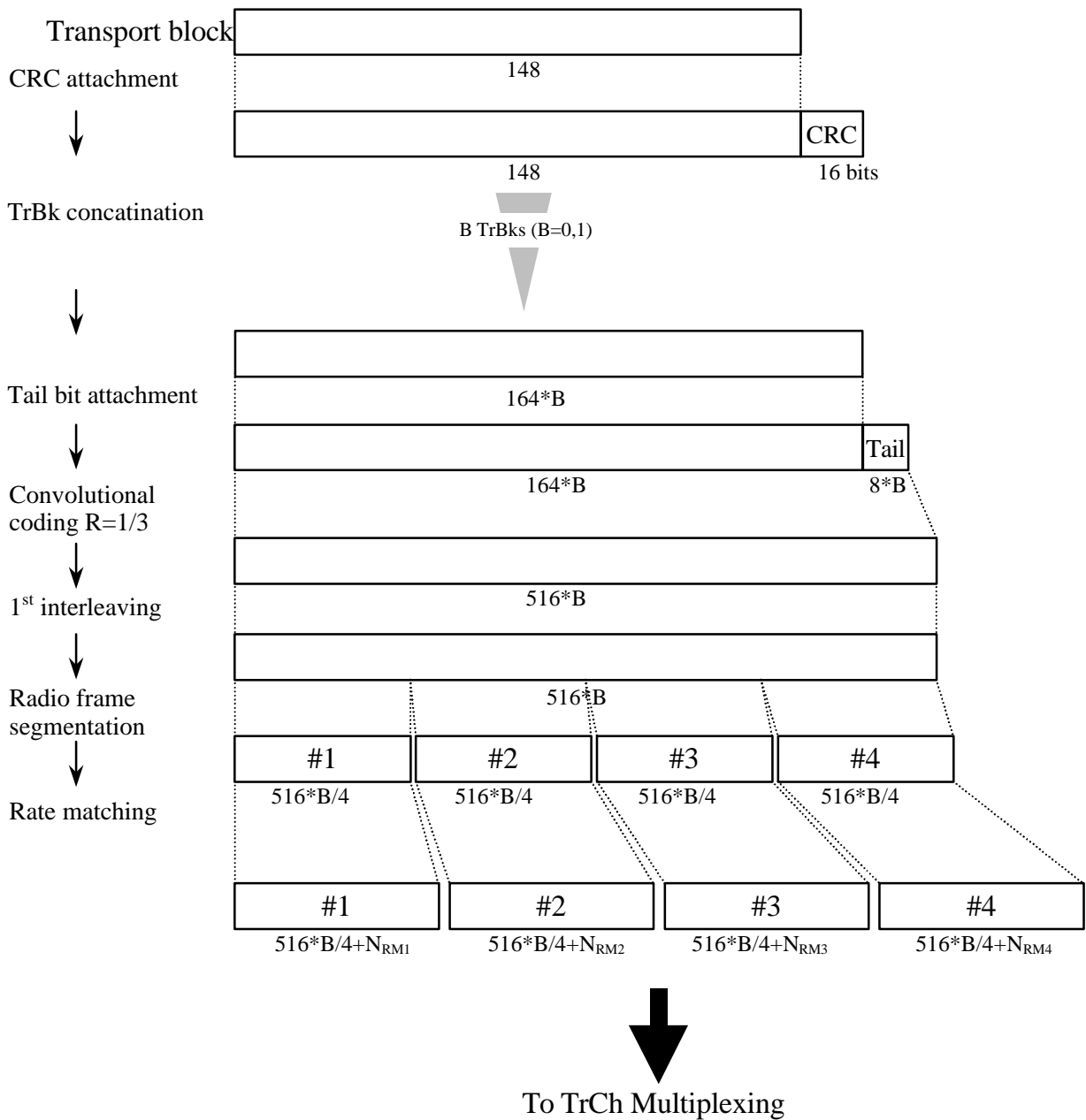

Figure 23: Channel coding and multiplexing example for 23.4 kbps data

## 4.2.1.4.1.2 Example for 12.2 kbps data

NOTE: This example can be applied to AMR speech.

**Table 20: Parameter examples for 12.2 kbps data**

The number of TrChs		3
Transport block size	TrCH#a	$N_{TrCHa} = 0, 39 \text{ or } 81, 103, \text{ and } 60$ bits
	TrCH#b	$N_{TrCHb} = 0 \text{ or } 103$ bits
	TrCH#c	$N_{TrCHc} = 0 \text{ or } 60$ bits
Transport block set size	#1	$N_{TrCHa}=81, N_{TrCHb}=103, N_{TrCHc}=60$ bits
	#2	$N_{TrCHa}=39, N_{TrCHb}=0, N_{TrCHc}=0$ bits
	#3	$N_{TrCHa}=0, N_{TrCHb}=0, N_{TrCHc}=0$ bits
CRC		12 bits (attached only to TrCh#1a)
CRC parity bit attachment for 0 bit transport block		Applied only to TrCH#a
Coding TTI		CC, coding rate = 1/3 for TrCh#1a, 2b coding rate = 1/2 for TrCh#3c 20 ms

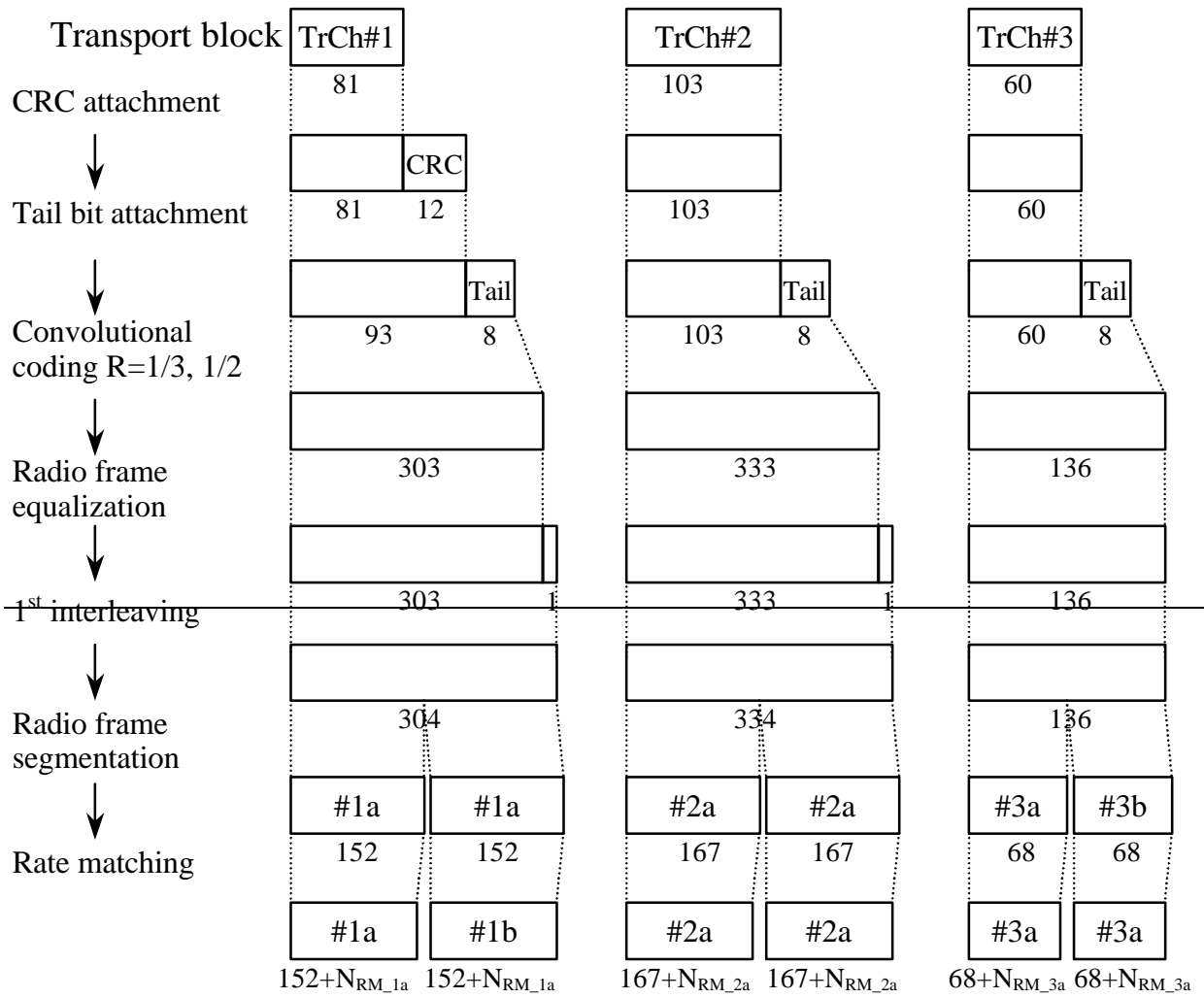

To TrCh Multiplexing

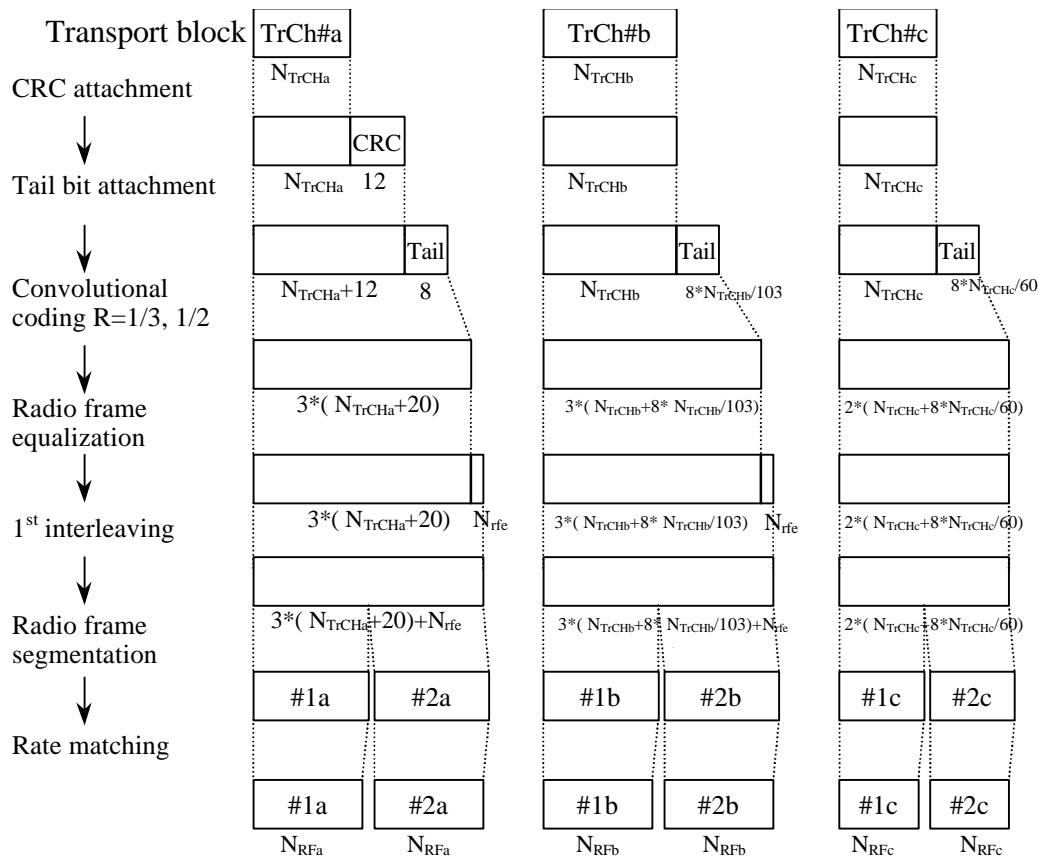

$$\begin{aligned}
 N_{RFa} &= [3*(N_{TrCHa}+20)+N_{RMa}+N_{rfe}]/2 \\
 N_{RFb} &= [3*(N_{TrCHb}+8*N_{TrCHb}/103)+N_{RMb}+N_{rfe}]/2 \\
 N_{RFc} &= [2*(N_{TrCHc}+8*N_{TrCHc}/60)+N_{RMc}]/2
 \end{aligned}$$

To TrCh Multiplexing

**\* CRC and tail bits for TrCH#a is attached even if  $N_{TrCHa}=0$  bits since CRC parity bit attachment for 0 bit transport block is applied.**

Figure 24: Channel coding and multiplexing example for 12.2 kbps data

4.2.1.4.1.3 Example of 28.8/57.6 kbps data

NOTE: This example can be applied to Modem or FAX.

**Table XX: Parameters for 28.8/57.6 kbps data**

The number of TrChs		1
Transport block size		576 bits
Transport block set size	28.8 kbps	576*B bits (B=0, 1, 2)
	57.6 kbps	576*B bits (B=0, 1, 2, 3, 4)
CRC		16 bits
Coding		Turbo coding, coding rate = 1/3
TTI		40 ms

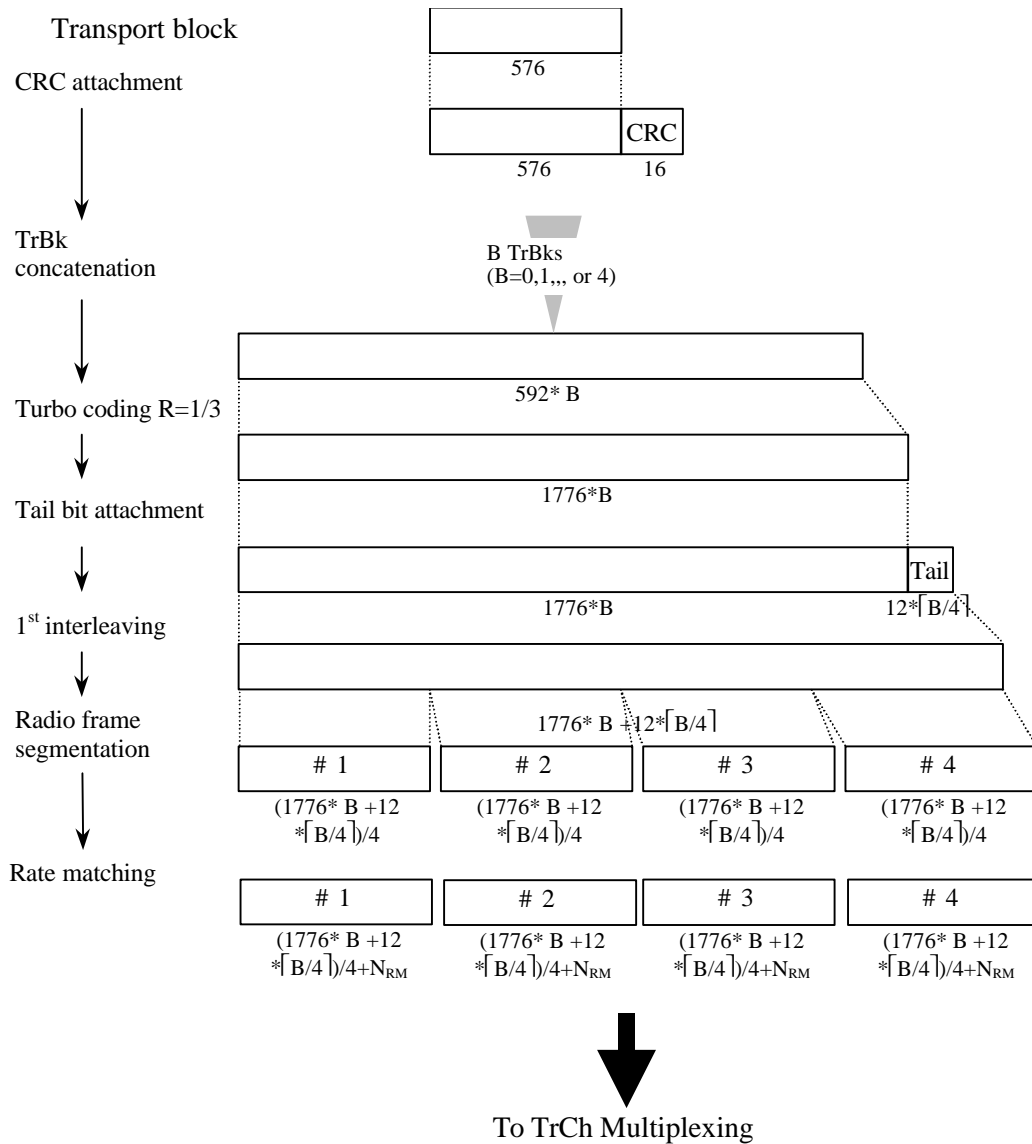

**Figure XX: Channel coding and multiplexing example for 28.8/57.6 kbps data**

## 4.2.1.4.1.34 Example of 64/128/384-144 kbps packet data

NOTE: In this example it is assumed, that maximum data rate of RLC payload is 64/128/144 kbps, and MAC and RLC overhead in a transport block is 16 bits.

**Table 21: Parameters for 64/128/144-384 kbps packet data**

The number of TrChs		1
Transport block size		336 bits
Transport block	64 kbps	1280 bits
Size: S	128 kbps	2560 bits
	384 kbps	3840 bits
Transport block set size	64 kbps	4280336*B bits (B = 0, 1, 2, 4)
	128 kbps	2560336*B bits (B = 0, 1, 2, 4, 8)
	384-144 kbps	3840336*B bits (B = 0, 1, 2, 4, 8, 9)
Code block	64 kbps	4
Segmentation: C	128 kbps	4
	384 kbps	1 (B = 0, 1) or 2 (B = 2)
CRC		16 bits
Coding		Turbo coding, coding rate = 1/3
TTI		20 ms



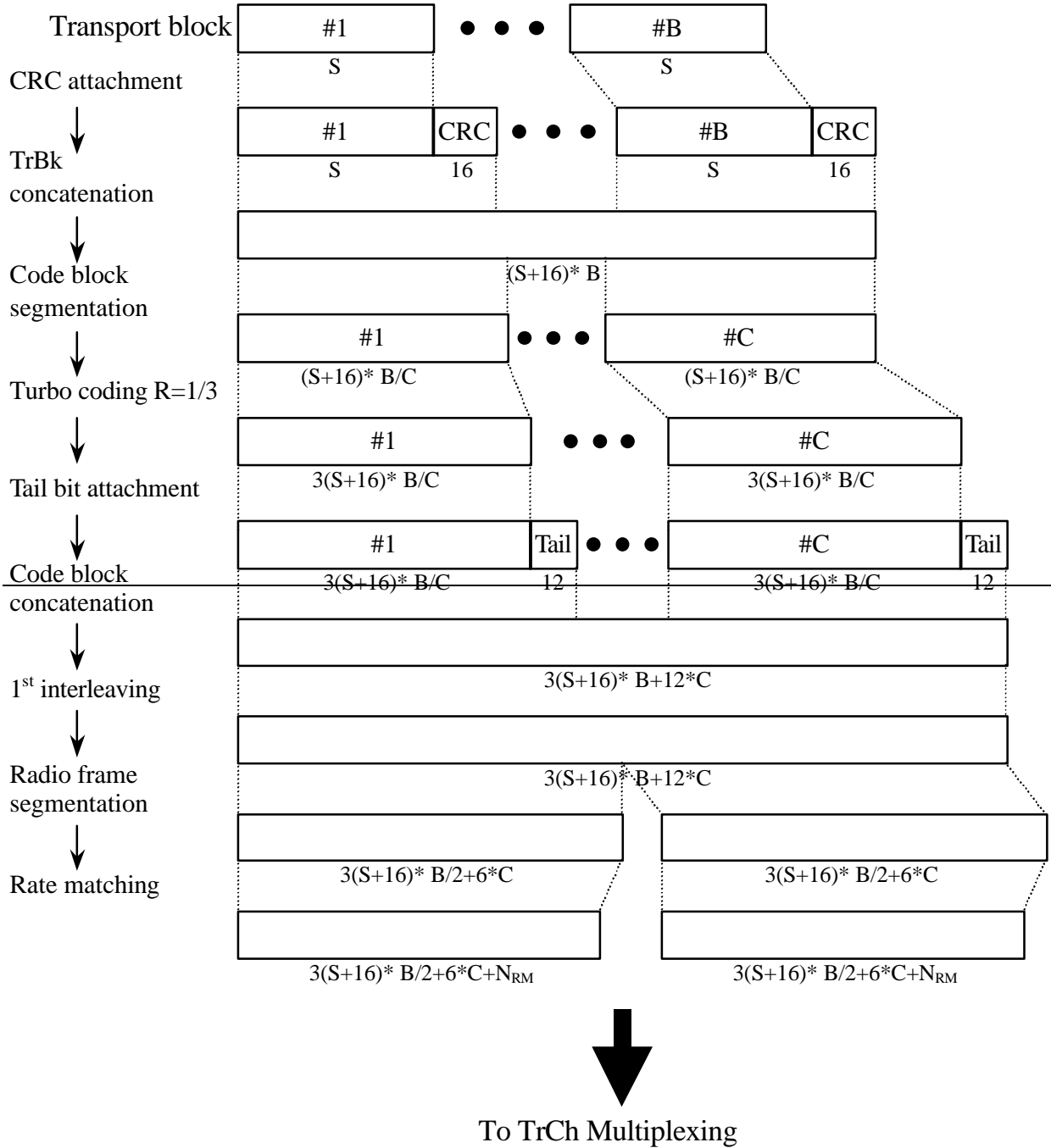

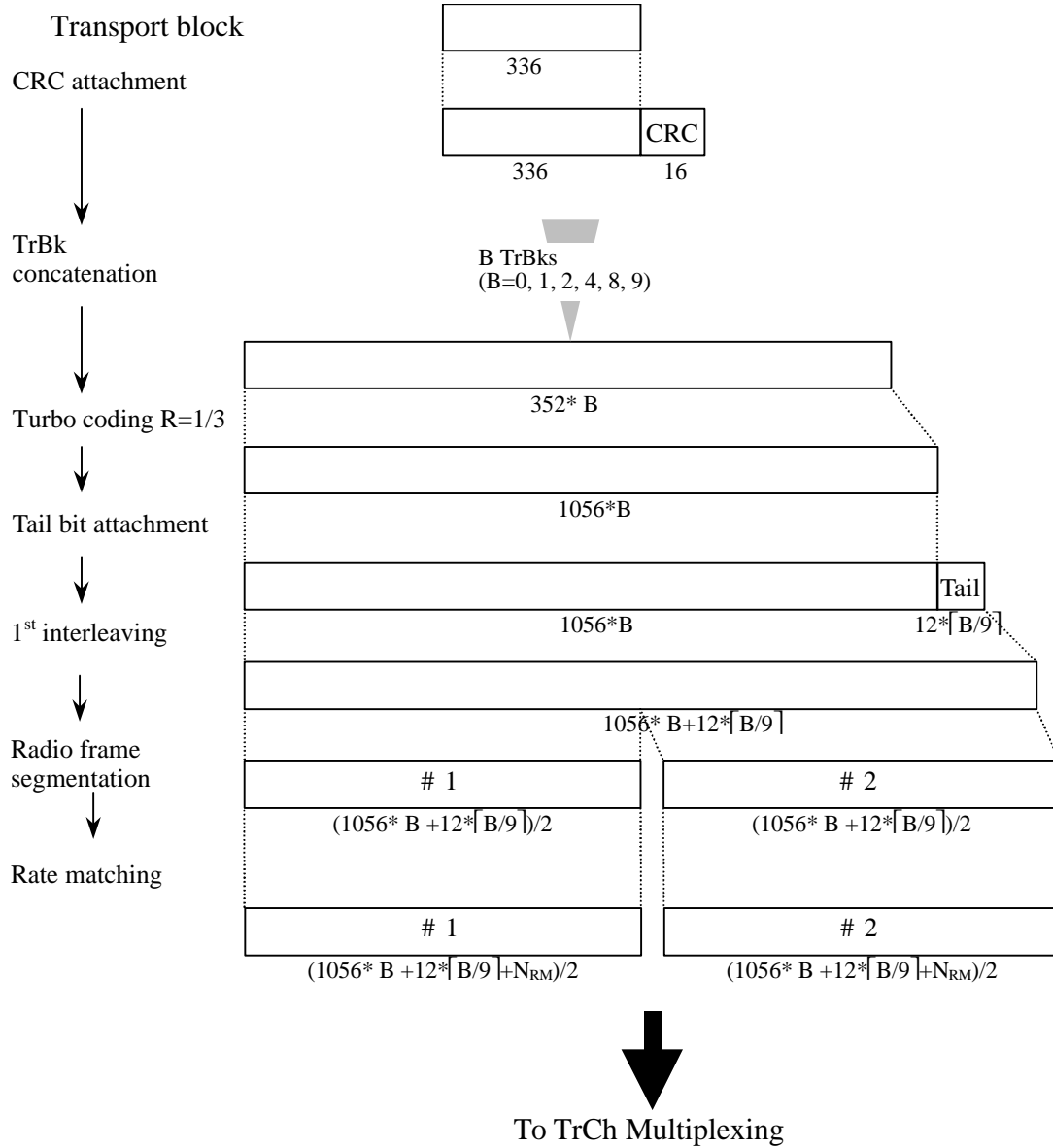

Figure 25: Channel coding and multiplexing example for 64/128/384-144 kbps packet data

## 4.2.1.4.1.4 Example of 384 kbps packet data

NOTE: In this example it is assumed, that the maximum data rate of RLC payload is 384 kbps, and MAC and RLC overhead in a transport block is 16 bits.

**Table 21: Parameters for 384 kbps packet data**

The number of TrChs	1
Transport block size	336 bits
Transport block set size	$336 * B$ bits ( $B = 0, 1, 2, 4, 8, 12$ for TTI=10ms, $B=0,1,2,4,8,12,24$ for TTI=20ms)
CRC	16 bits
Coding	Turbo coding, coding rate = 1/3
TTI	10 or 20 ms

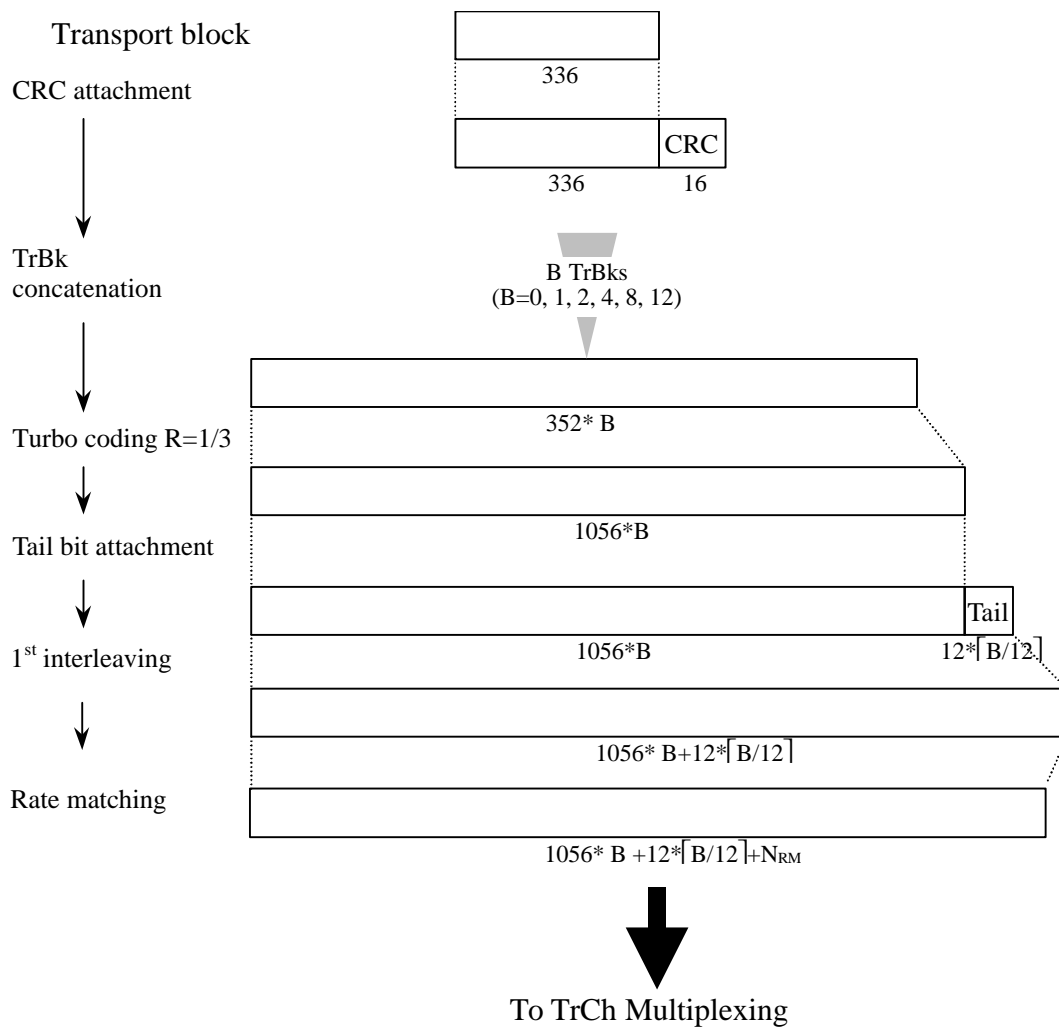
**Figure 25: Channel coding and multiplexing example for 384 kbps packet data in case of TTI=10ms**

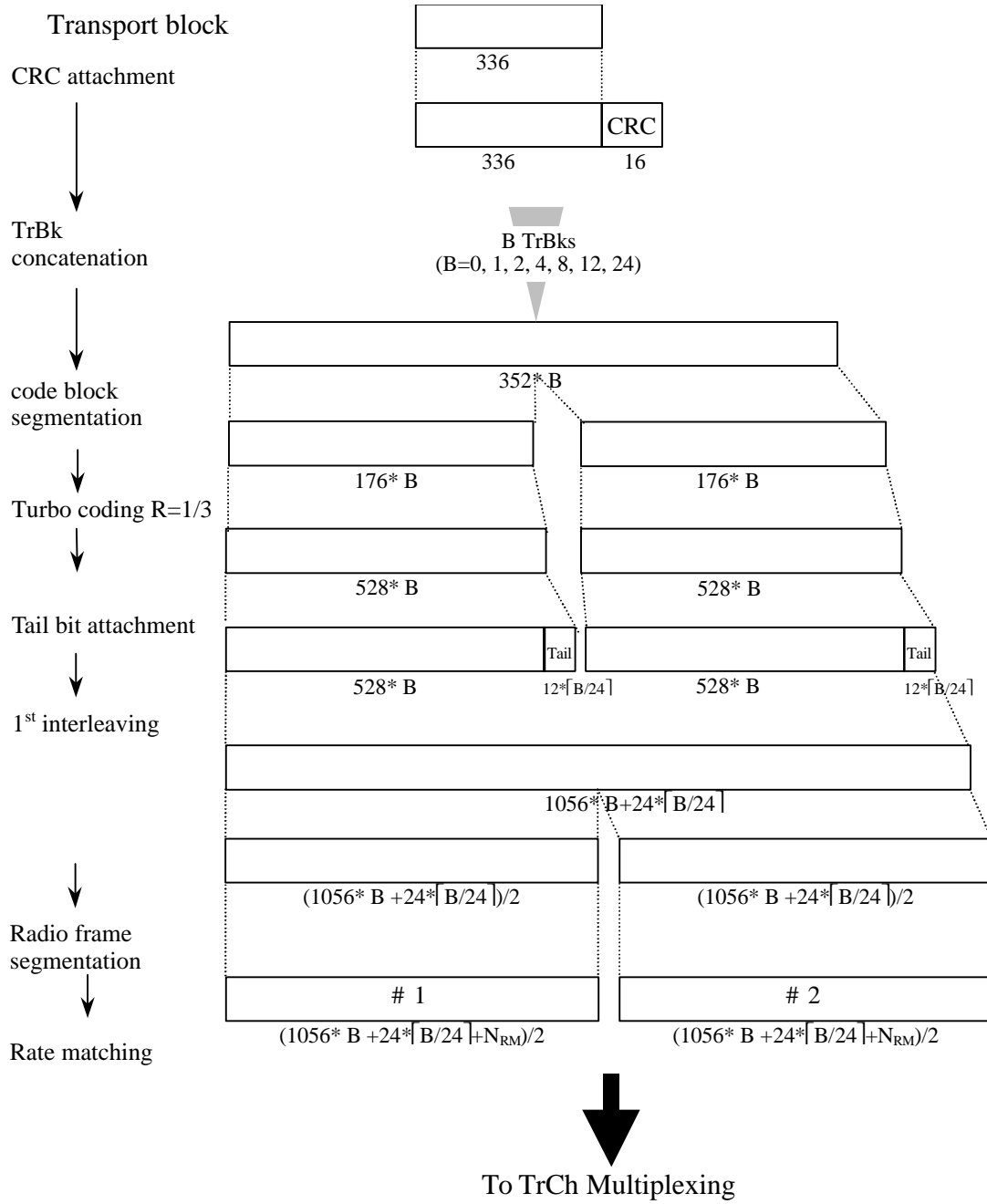

**Figure 25: Channel coding and multiplexing example for 384 kbps packet data in case of TTI=20ms**

4.2.1.4.1.4 Example for 64 kbps data

NOTE: This example can be applied to ISDN service.

**Table 22: Parameters for 64 kbps data**

The number of TrChs	1
Transport block size	<del>4280</del> 640 bits
Transport block set size	<del>4280</del> 4*640 bits
CRC	16 bits
Coding	Turbo coding, coding rate = 1/3
TTI	<del>20</del> 40 ms

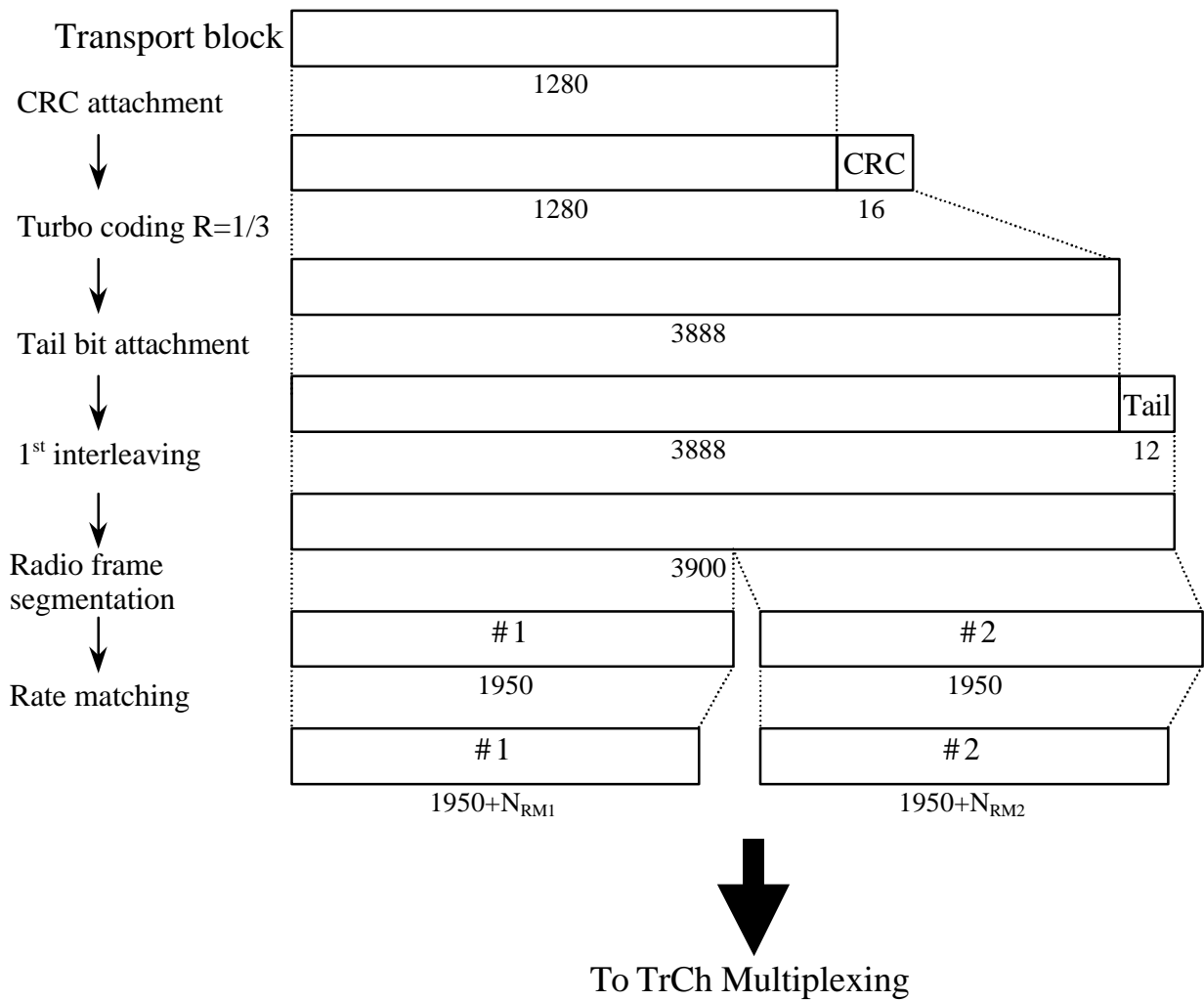

**Figure 26: Channel coding and multiplexing example for 64 kbps data**

4.2.1.4.2 TrCH multiplexing -> Physical channel mapping

4.2.1.4.2.1 Example for Stand-alone mapping of 23.4 kbps data

NOTE: This example can be applied to Stand-alone mapping of DCCH.

Table 23 shows example of physical channel parameters for Stand-alone mapping of 23.4 kbps data.

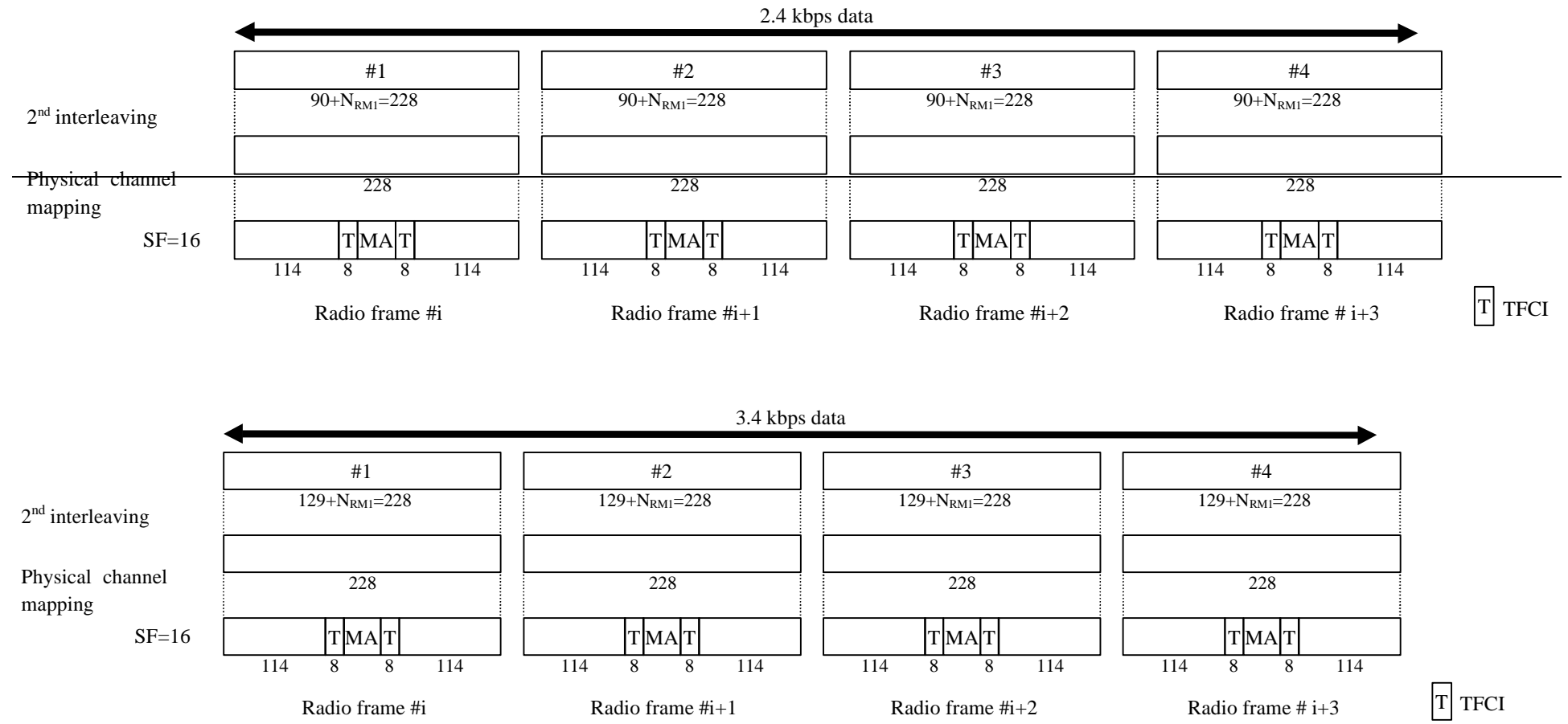

Figure 27: Channel coding and multiplexing example for Stand-alone mapping of 23.4 kbps data

**Table 23: Physical channel parameters for Stand-alone mapping of 23.4 kbps data**

Midamble	512 chips
Codes and time slots	SF16 x 1 code x 1 time slot
TFCI	16 bits per user
TPC	0 bit

4.2.1.4.2.2 Example for multiplexing of 12.2 kbps data and ~~23~~3.4 kbps data

NOTE: This example can be applied to multiplexing AMR speech and DCCH.



3G 25.944 Version 3.1.0 (2000-06)

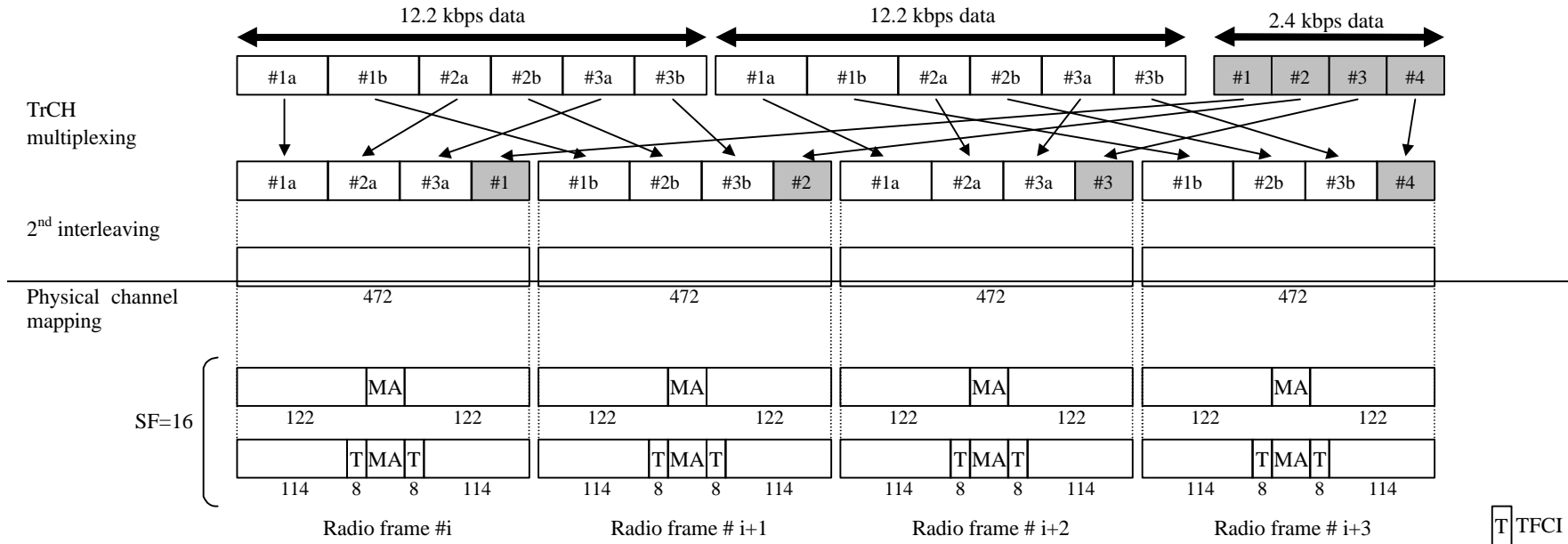

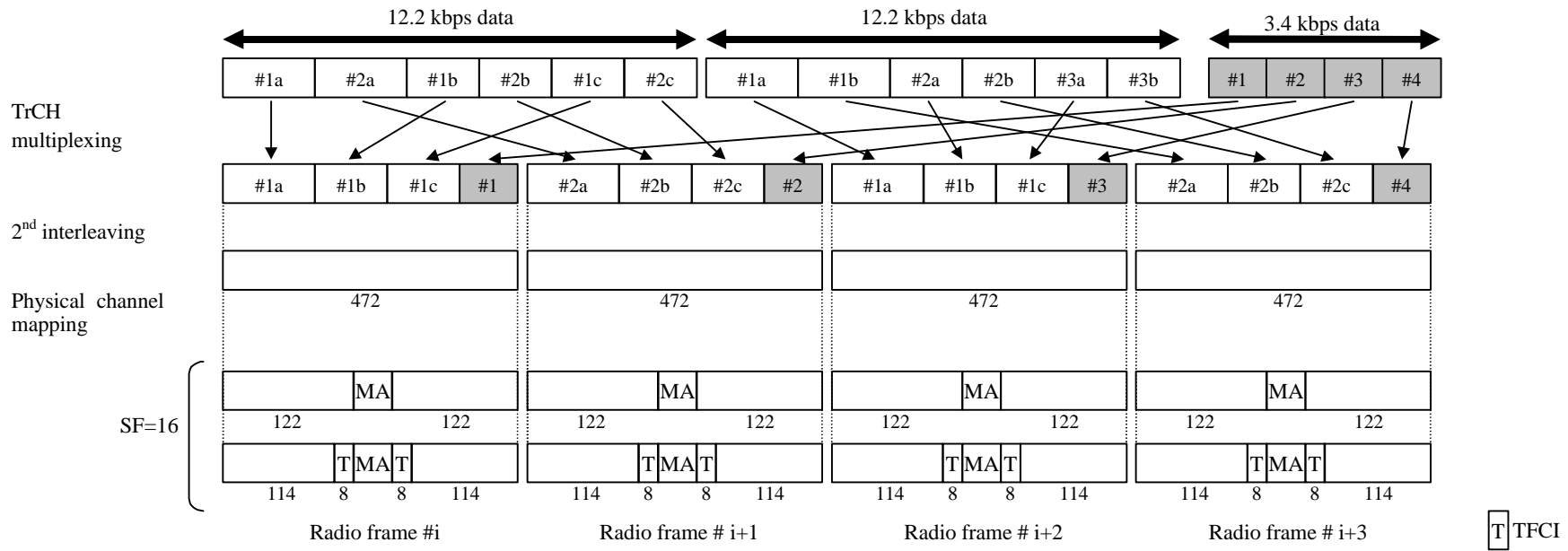

Figure 28: Channel coding and multiplexing example for multiplexing of 12.2 kbps data and 3.4 kbps data

Table 24: Physical channel parameters for multiplexing of 12.2 kbps data and 3.4 kbps data

Midamble	512 chips
Codes and time slots	SF16 x 2 code x 1 time slot
TFCI	16 bits per user
TPC	0 bit

4.2.1.4.2.3 Example for multiplexing of 28.8/57.6 kbps data 3.4 kbps data

NOTE: This example can be applied to multiplexing of Modem/FAX and DCCH.

Table XX shows example of physical channel parameters for multiplexing of 28.8/57.6 kbps data and 3.4 kbps data.

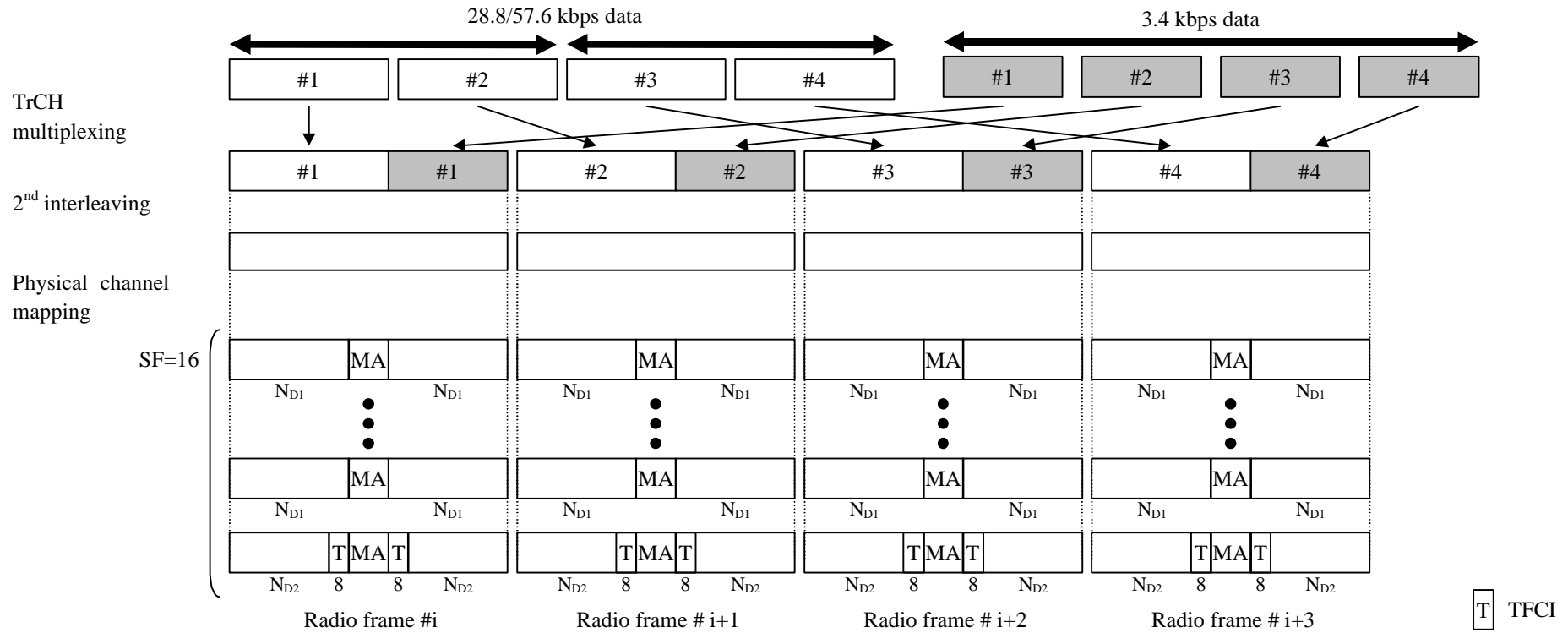

Figure 29: Channel coding and multiplexing example for multiplexing 28.8/57.6 kbps data and 3.4 kbps data

**Table 25: Physical channel parameters for multiplexing of 28.8/57.6 kbps packet data and 3.4 kbps data**

<u>Midamble</u>	<u>28.8/57.6 kbps</u>	<u>512 chips</u>
<u>N<sub>D1</sub>, N<sub>D2</sub></u>	<u>28.8/57.6 kbps</u>	<u>122 bits, 114 bits</u>
<u>Code &amp; time</u>	<u>28.8 kbps</u>	<u>SF16 x 2 codes x 1 time slot</u>
<u>slots</u>	<u>57.6 kbps</u>	<u>SF16 x 4 codes x 1 time slot</u>
<u>TFCI</u>		<u>16 bits per user</u>
<u>TPC</u>		<u>0 bit</u>

4.2.1.4.2.3 Example for multiplexing of 64/128/144/384 kbps packet data and 32.4 kbps data

NOTE: This example can be applied to multiplexing 64/128/144/384 kbps packet data and DCCH.

Table 25 shows example of physical channel parameters for multiplexing of 64/128/144/384 kbps packet data and 23.4 kbps data.

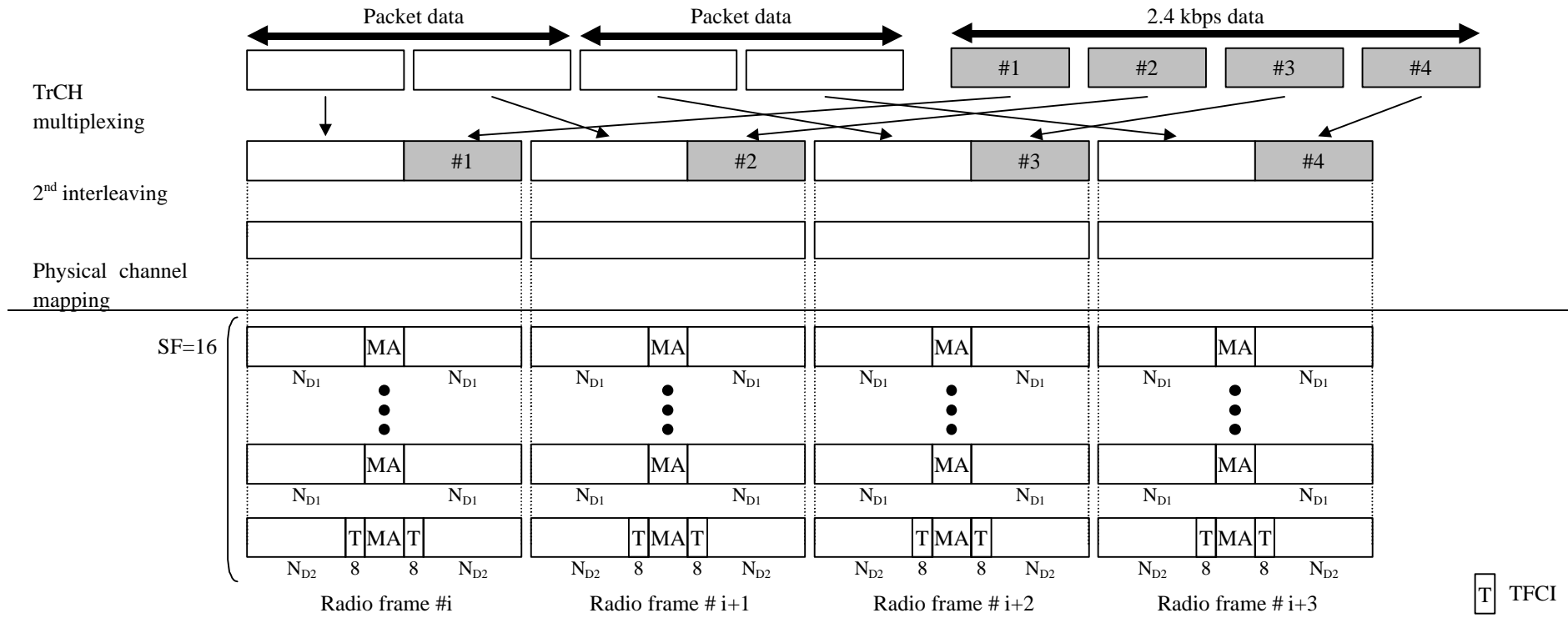

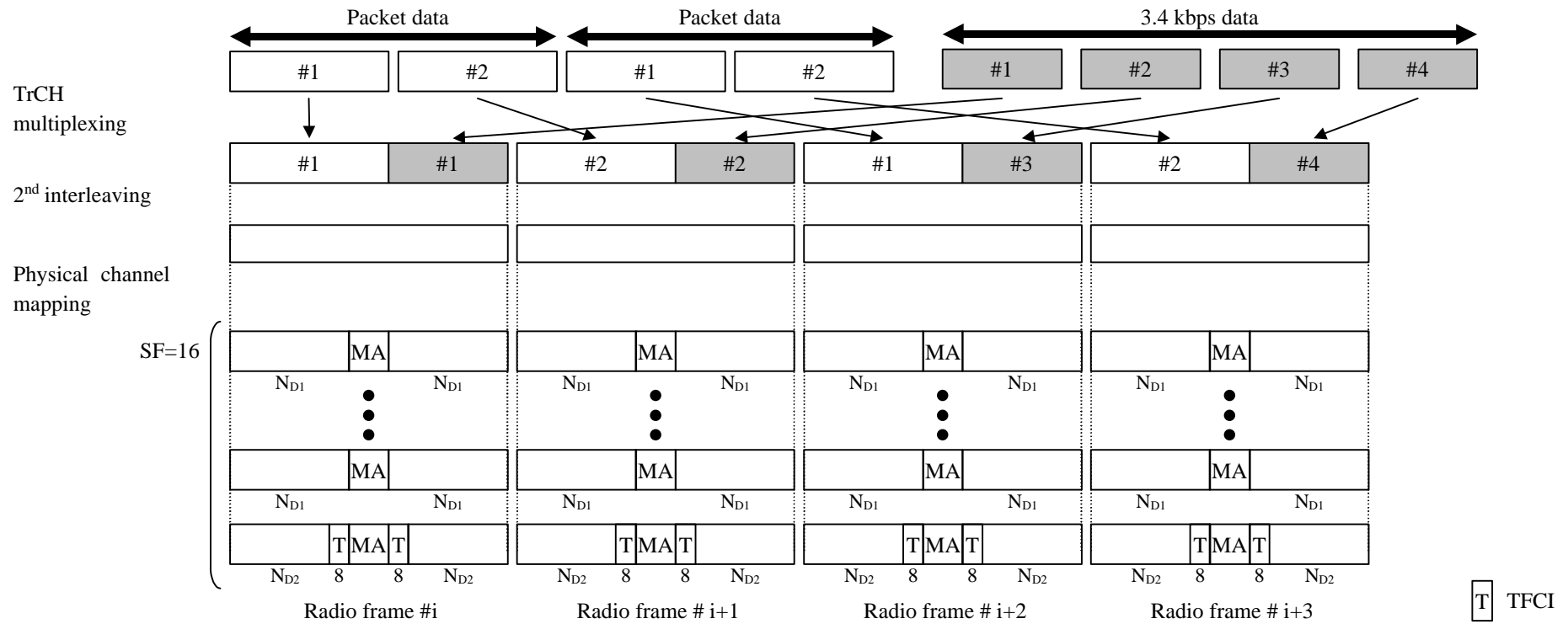

Figure 29: Channel coding and multiplexing example for multiplexing of 64/128/384-144 kbps packet data and 23.4 kbps data

Table 25: Physical channel parameters for multiplexing of 64/128/144/384 kbps packet data and 23.4 kbps data

Midamble	64 kbps	512 chips
	128 & 144 & 384 kbps	256 chips
$N_{D1}, N_{D2}$	64 kbps	122 bits, 114 bits
	128 & 144 & 384 kbps	138 bits, 130 bits
Code & time slots	64 kbps	SF16 x 5 codes x 1 time slot
	128 kbps	SF16 x 98 codes x 1 time slot
	144 kbps	SF16 x 9 codes x 1 time slot
	384 kbps	SF16 x 8 codes x 3 time slots
TFCI	16 bits per user	
TPC	0 bit	

4.2.1.4.2.4 Example for multiplexing of 64 kbps data and 23.4 kbps data

NOTE: This example can be applied to multiplexing ISDNs data and DCCH.

Table 26 shows example of physical channel parameters for multiplexing of ~~64/128/384~~ kbps ~~packet~~-data and 32.4 kbps data.



3G 25.944 Version 3.1.0 (2000-06)

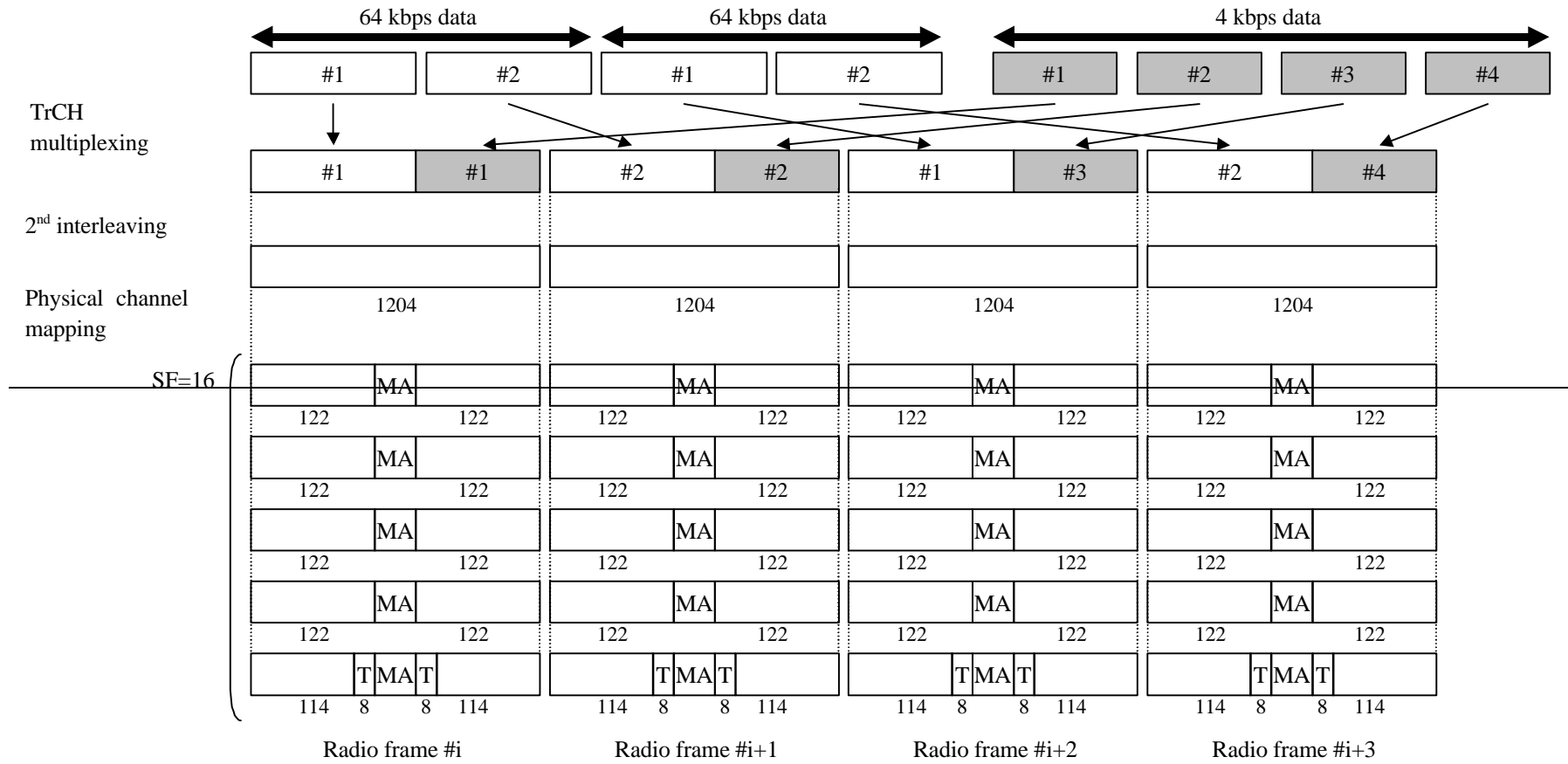

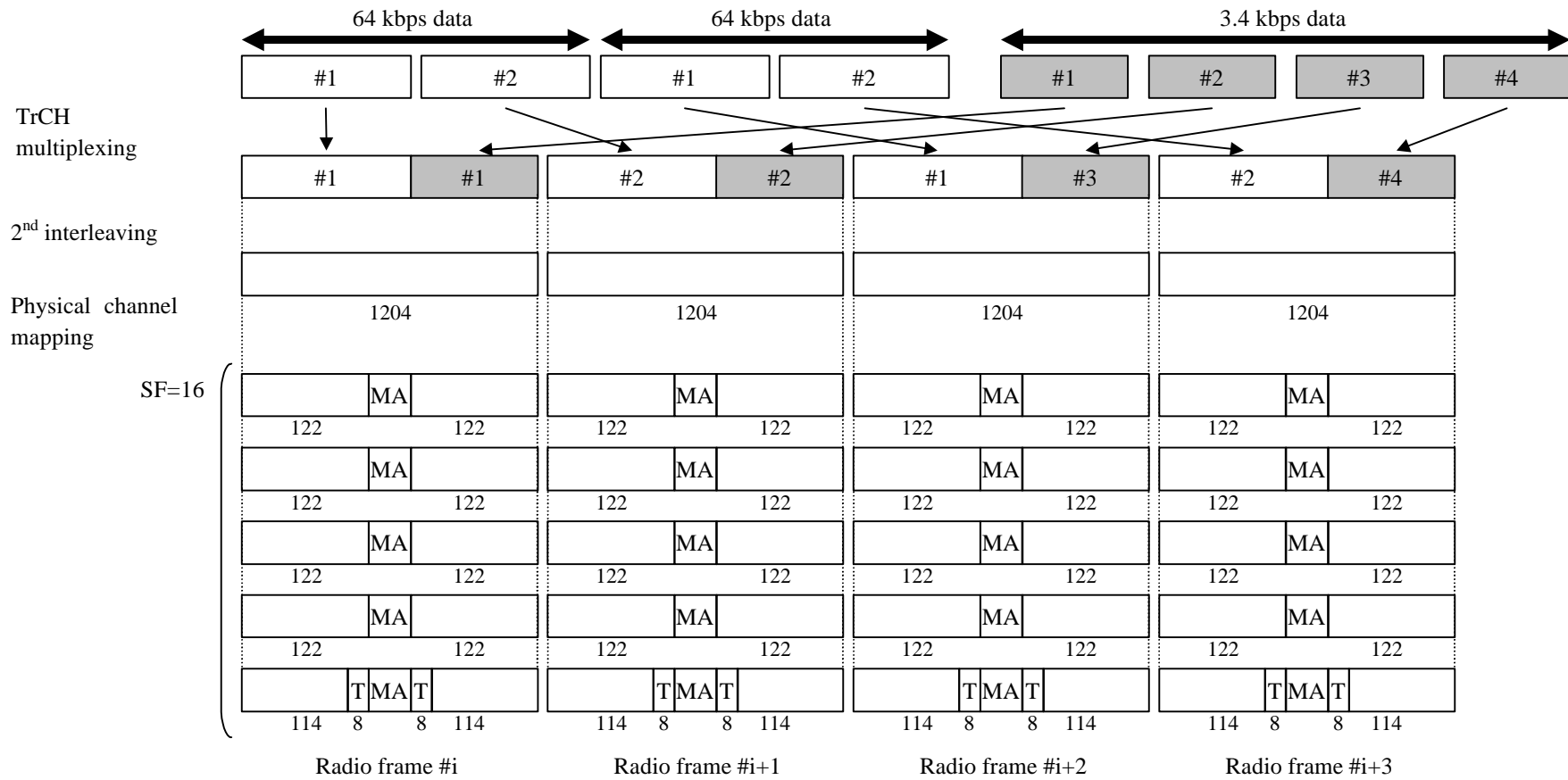

Figure 30: Channel coding and multiplexing example for multiplexing of 64/128/384\_kbps packet data and 3.4 kbps data

Table 26: Physical channel parameters for multiplexing of 64/128/384 kbps packet data and 3.4 kbps data

Midamble	512 chips
Code & time slots	SF16 x 5 codes x 1 time slot
TFCI	16 bits per user
TPC	0 bit

4.2.1.4.2.4 Example for multiplexing of 12.2 kbps data, 64/128/144/384 kbps packet data and 3.4 kbps data

NOTE: This example is corresponding to multiplexing of AMR speech, 64/128/144/384 kbps packet and DCCH.

Table 26 shows example of physical channel parameters for multiplexing of 12.2 kbps data, 64/128/144/384 kbps packet data and 3.4 kbps data.

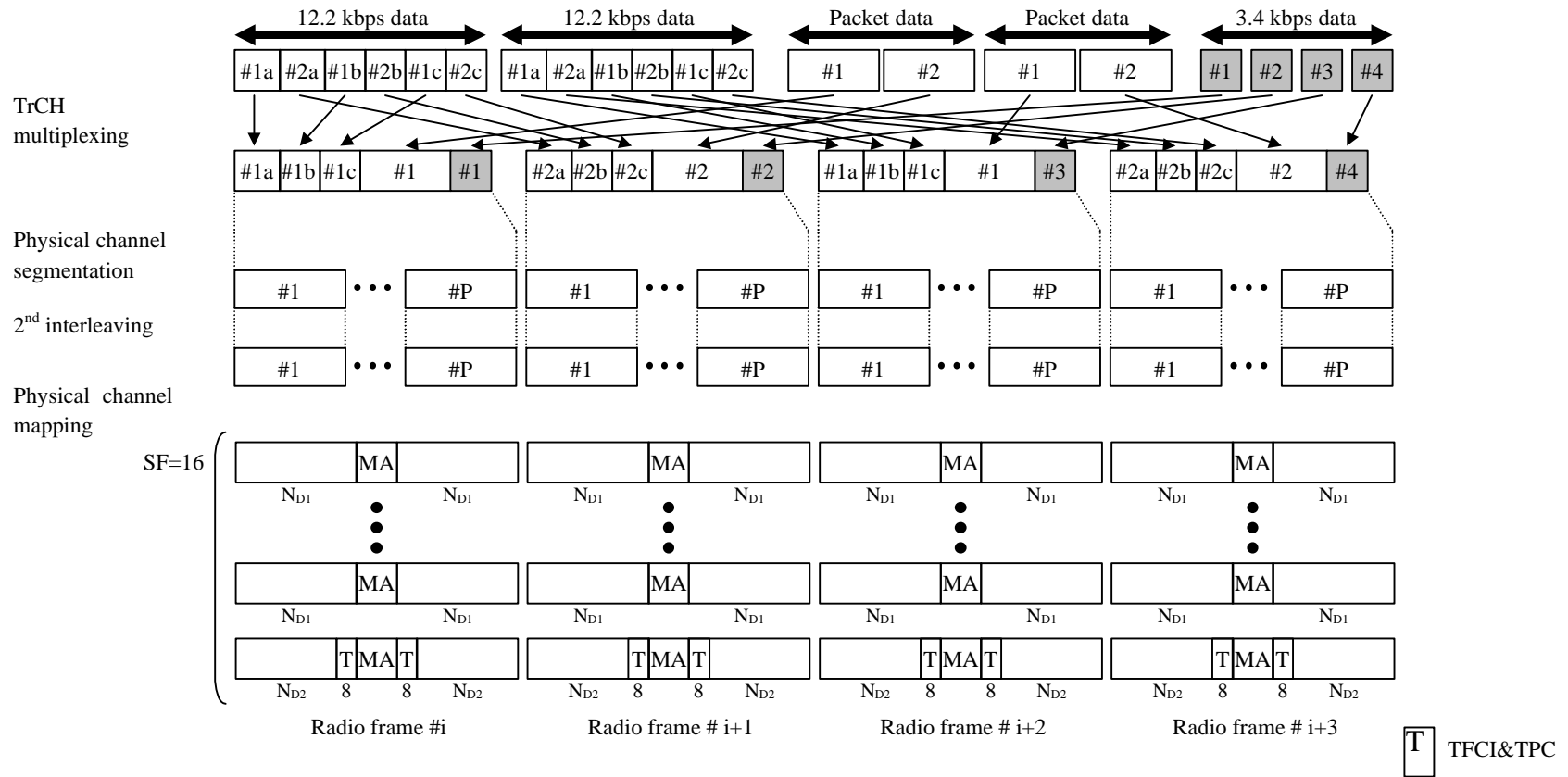

Figure 30: Channel coding and multiplexing example for multiplexing of 12.2 kbps data, 64/128/144/384 kbps packet data and 3.4 kbps data

Table 26: Physical channel parameters for multiplexing of 12.2 kbps data, 64/128/144/384 kbps packet data and 3.4 kbps data

3G 25.944 Version 3.1.0 (2000-06)

<u>Data rate (kbps)</u>	<u>No. of timeslots</u>	<u>No. of physical channels with SF16 per used TS</u>	<u>Midamble length</u>	<u>N<sub>TFCI</sub></u>	<u>N<sub>TPC</sub></u>
<u>64</u>	<u>1</u>	<u>5</u>	<u>512 chips</u>	<u>16</u>	<u>0</u>
<u>128</u>	<u>1</u>	<u>8</u>	<u>256 chips</u>	<u>16</u>	<u>0</u>
<u>144</u>	<u>1</u>	<u>9</u>	<u>256 chips</u>	<u>16</u>	<u>0</u>
<u>384</u>	<u>3</u>	<u>8</u>	<u>256 chips</u>	<u>16</u>	<u>0</u>

## 4.2.2 Uplink

### 4.2.2.1 RACH

**Table 27: Parameters for RACH**

Transport block size	$N_{RACH}=168$ or 360 bits
CRC	<del>8</del> 16 bits
Coding	CC, coding rate = 1/2
TTI	10 ms
Midamble	512 chips
Codes and time slots	SF = 16 x 1 x 1 time slot <u>or</u> SF = 8 x 1 x 1 time slot
TFCI	0 bit
TPC	0 bit

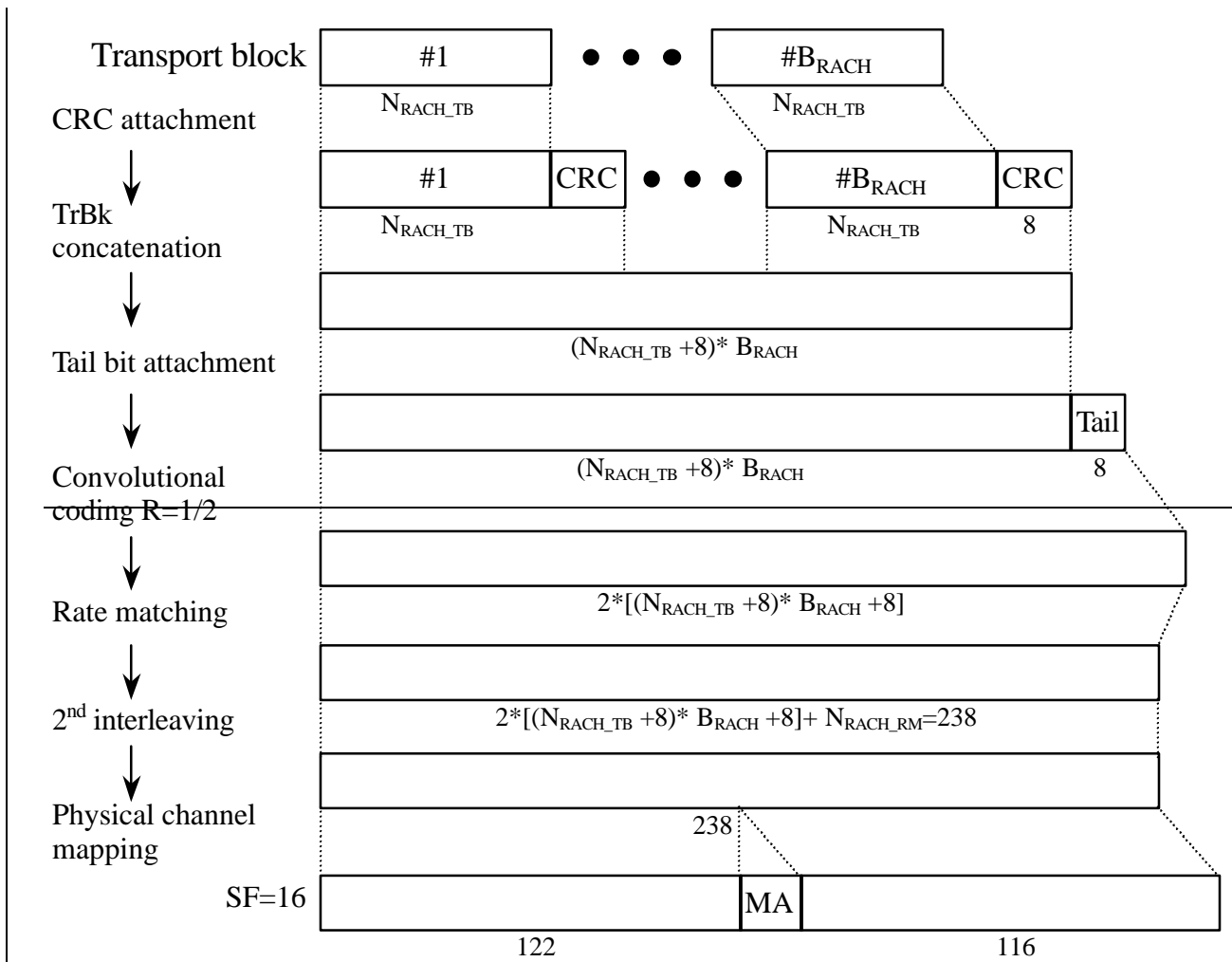

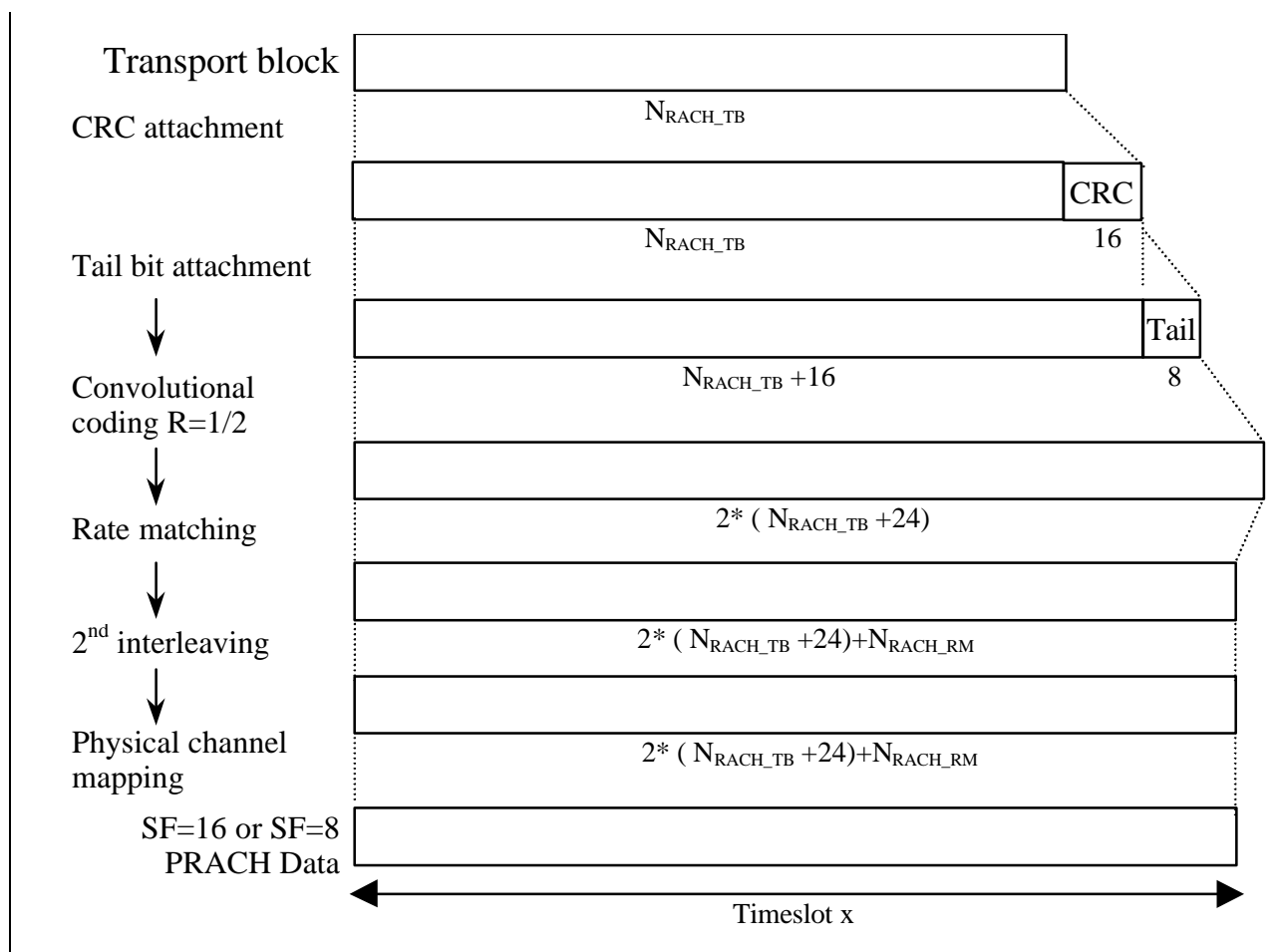

Figure 31: Channel coding and multiplexing example for RACH

## 4.2.2.2 Example for DCH

### 4.2.2.2.1 DCH-> Radio frame segmentation

See 4.2.1.4.2.



#### 4.2.2.2.2 TrCH multiplexing -> Physical channel mapping

##### 4.2.2.2.2.1 Example for Stand-alone mapping of 2.4 kbps data

NOTE: This example can be applied to Stand-alone mapping of DCCH.

Table 28 shows example of physical channel parameters for Stand-alone mapping of 2.4 kbps data.

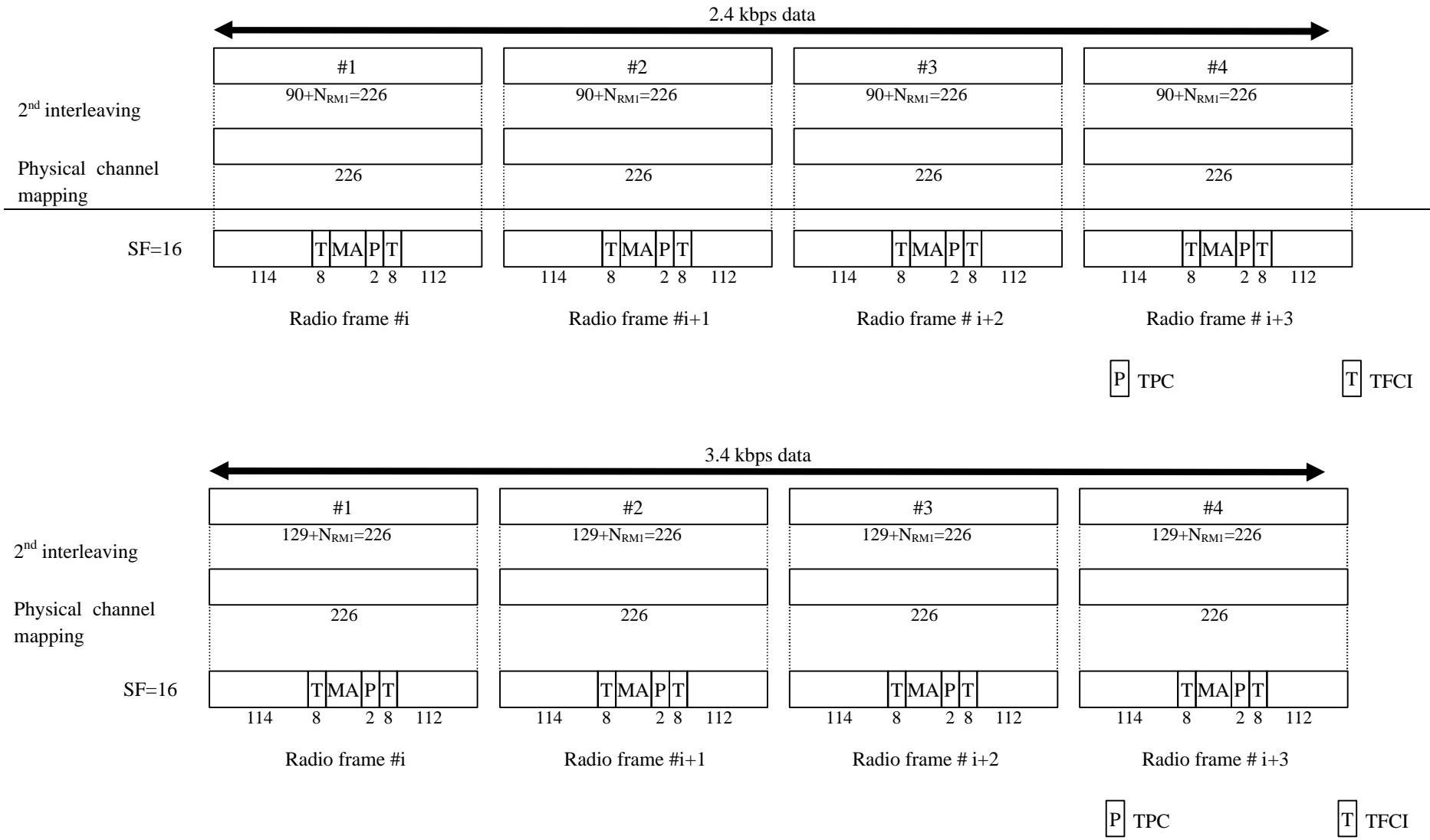

Figure 32: Channel coding and multiplexing example for Stand-alone mapping of 2.4 kbps data

**Table 28: Physical channel parameters for Stand-alone mapping of 2.4 kbps data**

Midamble	512 chips
Codes and time slots	SF16 x 1 code x 1 time slot
TFCI	16 bits per user
TPC	2-bit

4.2.2.2.2.2 Example for multiplexing of 12.2 kbps data and 23.4 kbps data

NOTE: This example can be applied to multiplexing AMR speech and DCCH.

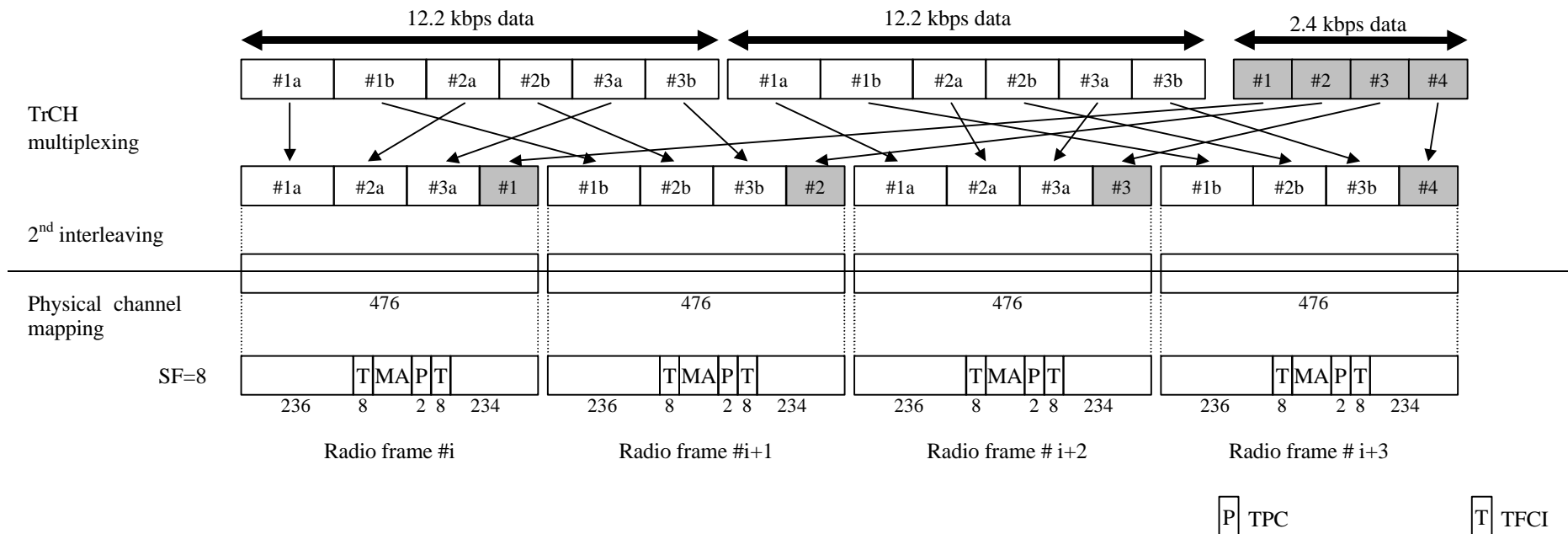

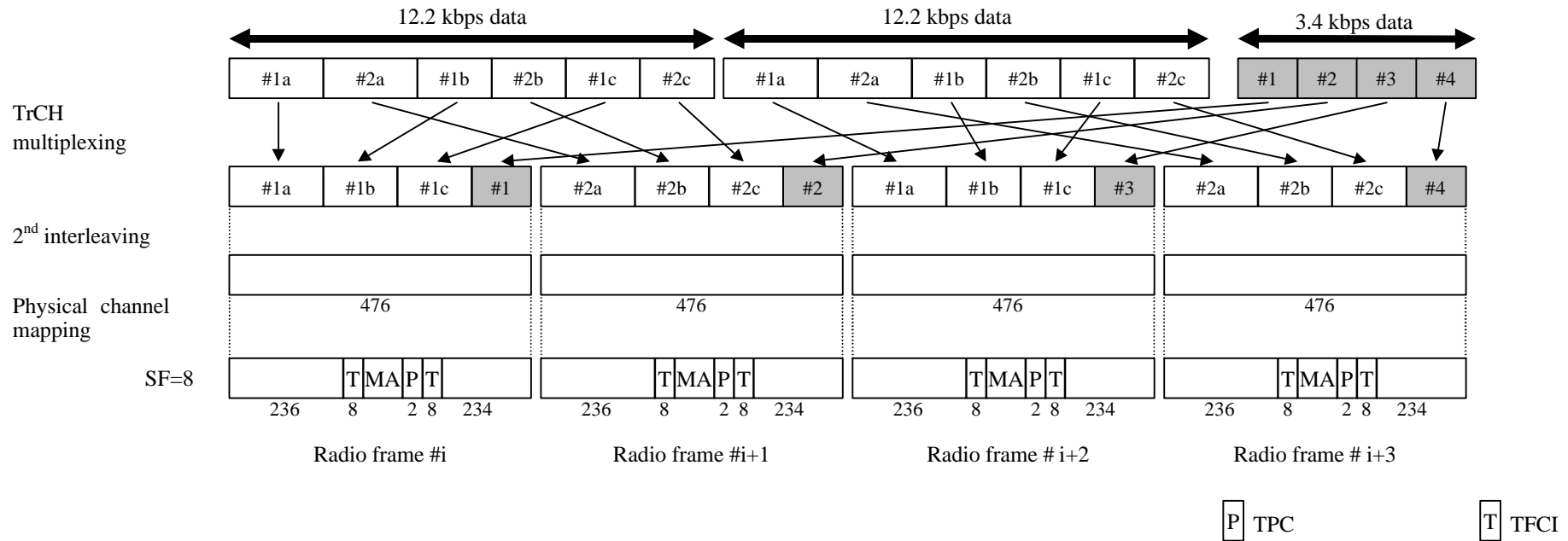

Figure 33: Channel coding and multiplexing example for multiplexing of 12.2 kbps data and 3.4 kbps data

Table 29: Physical channel parameters for multiplexing of 12.2 kbps data and 3.4 kbps data

Midamble	512 chips
Codes and time slots	SF8 x 1 code x 1 time slot
TFCI	16 bits per user
TPC	2 bit

4.2.2.2.3 Example for multiplexing of 28.8/57.6 kbps data and 3.4 kbps data

NOTE: This example can be applied to multiplexing of Modem/FAX and DCCH.

Table 30 shows example of physical channel parameters for multiplexing of 28.8/57.6 kbps data and 3.4 kbps data.

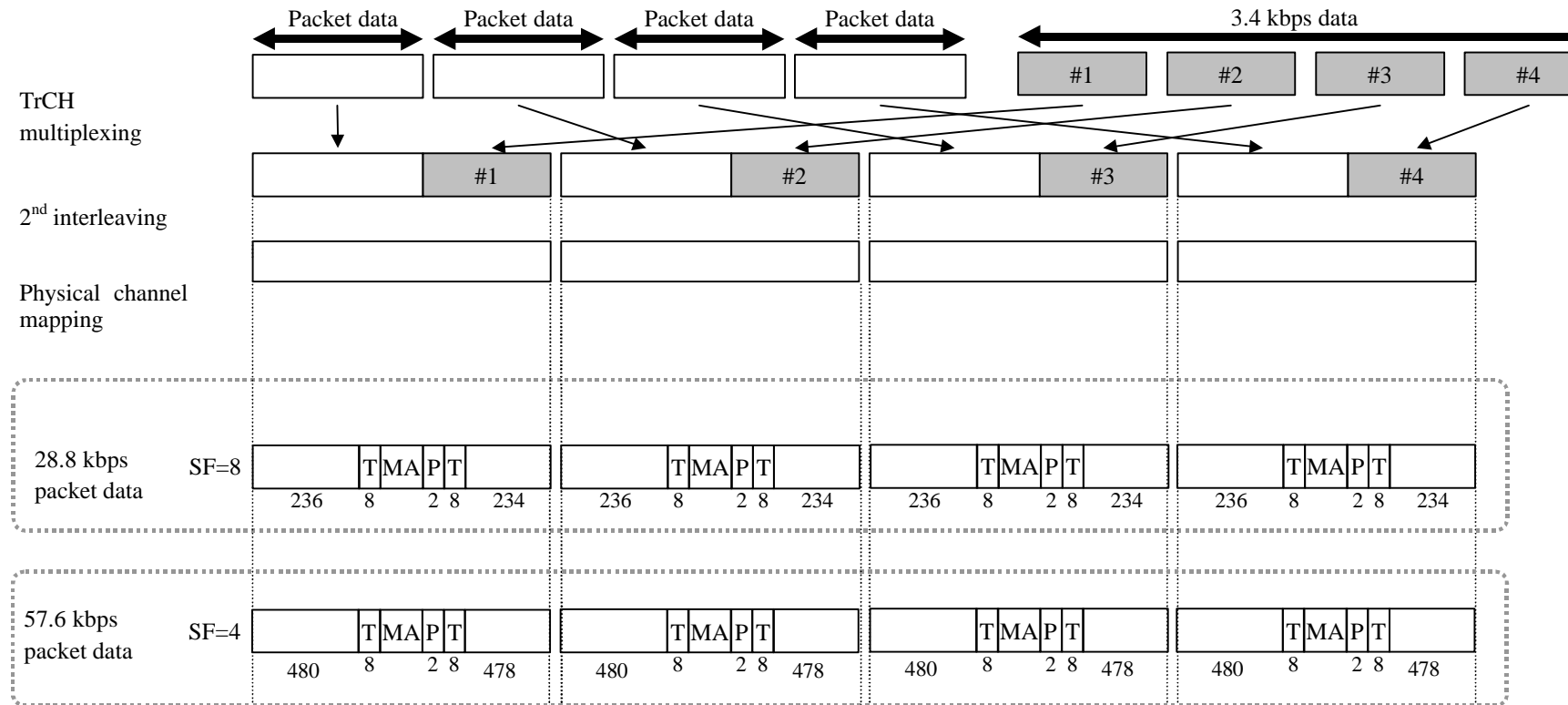

Figure 34: Channel coding and multiplexing example for multiplexing of 28.8/57.6 kbps data and 3.4 kbps data

**Table 30: Physical channel parameters for multiplexing of 28.8/57.6 kbps data and 3.4 kbps data**

Midamble	28.8/57.6 kbps	512 chips
Codes & time slots	28.8 kbps	(SF4 x 1 code) x 1 time slot
	57.6 kbps	(SF2 x 1 code) x 1 time slot
TFCI	16 bits per user	
TPC	2 bit	



4.2.2.2.2.3 Example for multiplexing of 64/128/144/384 kbps packet data and 23.4 kbps data

NOTE: This example can be applied to multiplexing 64/128/144/384 kbps packet data and DCCH.

Table 30 shows example of physical channel parameters for multiplexing of 64/128/144/384 kbps packet data and 23.4 kbps data.

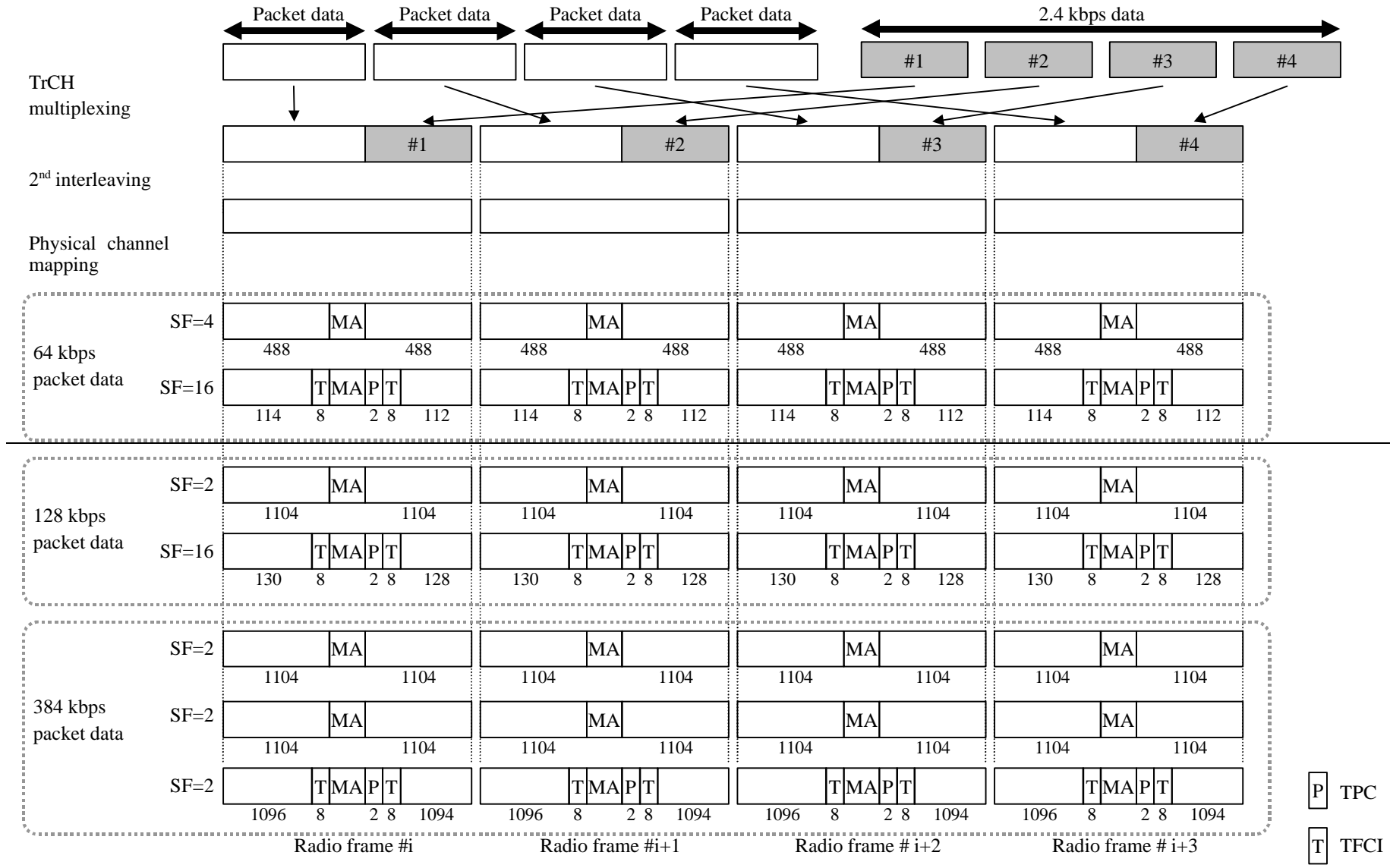

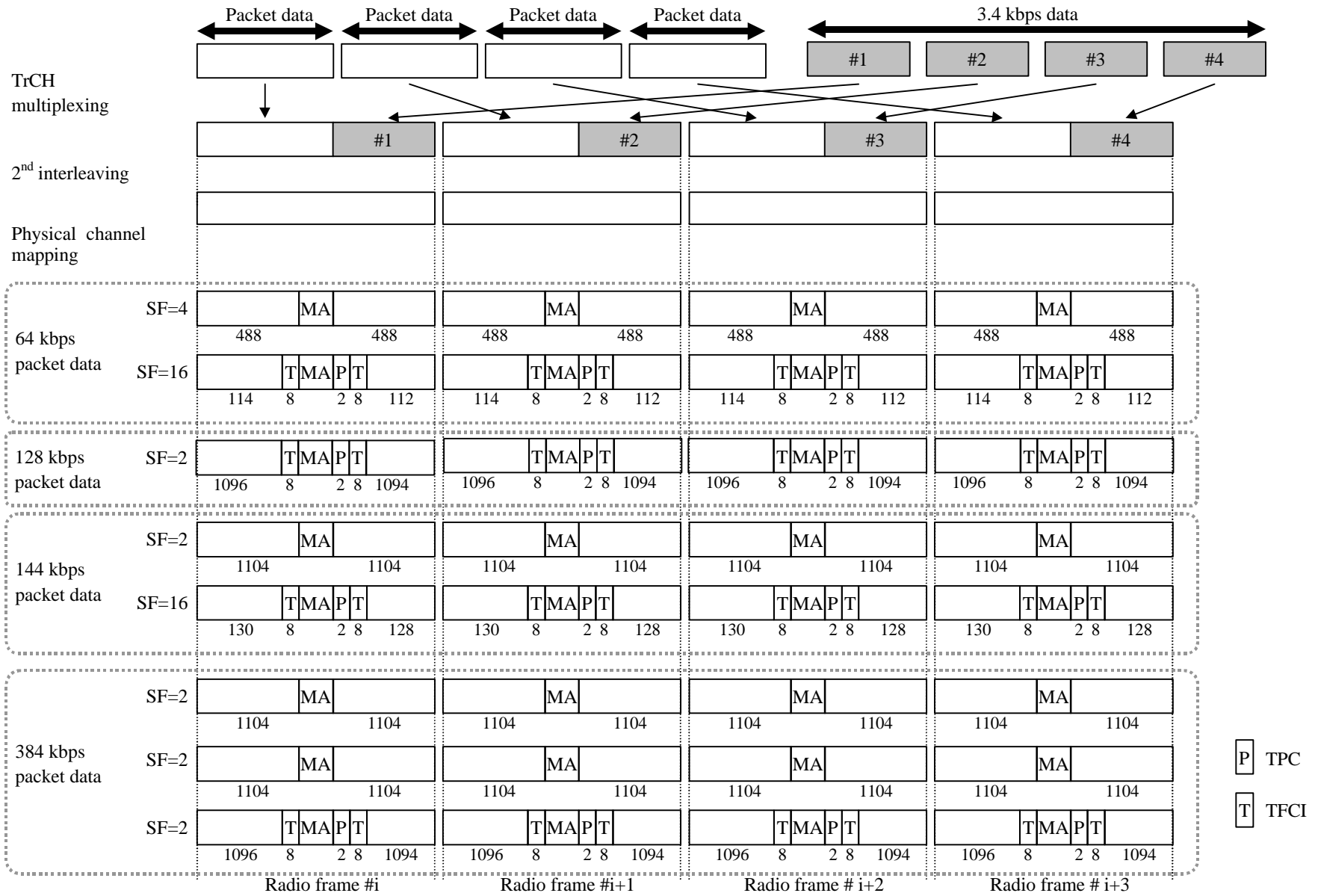

Figure 34: Channel coding and multiplexing example for multiplexing of 64/128/144/384 kbps packet data and 3.4 kbps data

**Table 30: Physical channel parameters for multiplexing of 64/128/144/384 kbps packet data and 23.4 kbps data**

Midamble	64 kbps	512 chips
	128 & 144 & 384 kbps	256 chips
Codes & time slots	64 kbps	{{(SF16 x 1 code) + (SF4 x 1 code)} x 1 time slot
	128 kbps	{{(SF16 x 1 code) + (SF2 x 1 code)} x 1 time slot
	144 kbps	{{(SF16 x 1 code) + (SF2 x 1 code)} x 1 time slot
	384 kbps	SF2 x 1 code x 3 time slot
TFCI		16 bits per user
TPC		2 bit

NOTE: As an additional example, physical channels can also be mapped without using multicode per timeslot, e.g.:

for 64kbps: (SF16 x 1 code x 1 timeslot) + (SF4x 1 code x 1 timeslot)

for 64kbps: (SF2 x 1 code x 1 timeslot)

for ~~128kbps~~144kbps: (SF16 x 1 code x 1 timeslot) + (SF2x 1 code x 1 timeslot)

for ~~128kbps~~144kbps: (SF1 x 1 code x 1 timeslot)

#### 4.2.2.2.2.4 Example for multiplexing of 64 kbps data and ~~23.4~~ kbps data

NOTE: This example can be applied to multiplexing ISDNs data and DCCH.

Table 31 shows example of physical channel parameters for multiplexing of ~~64/128/384~~ kbps packet data and ~~23.4~~ kbps data.

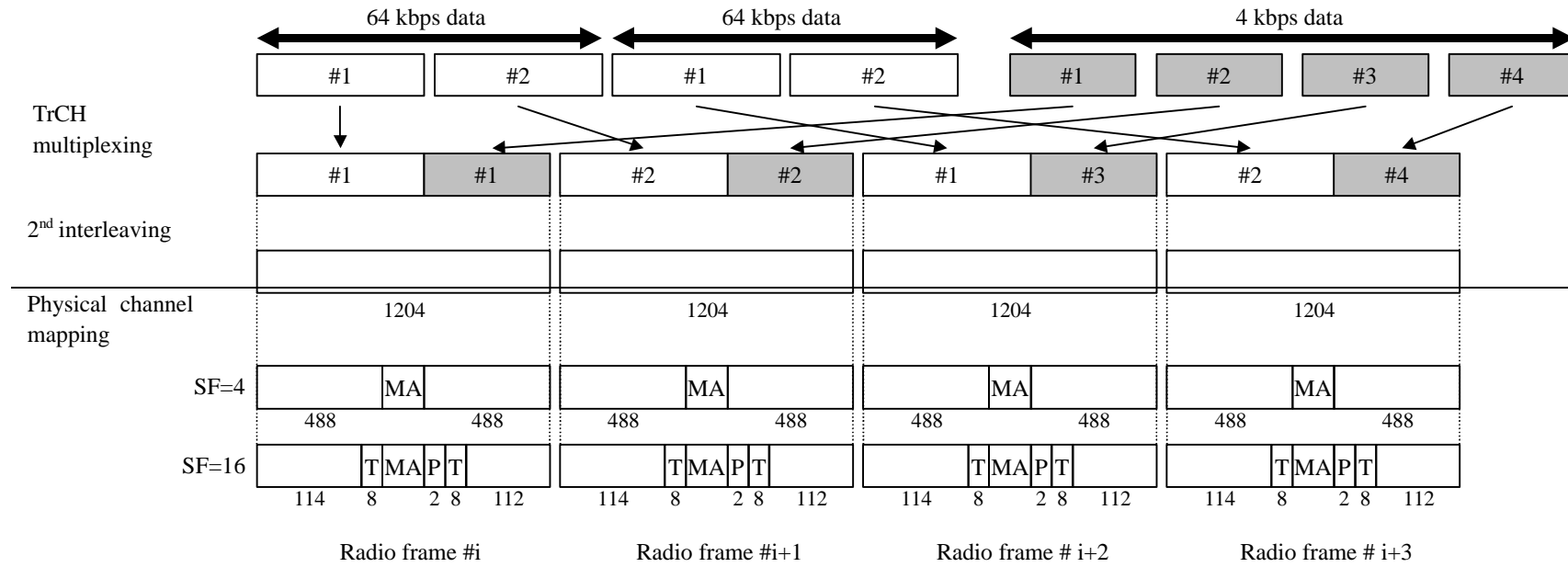

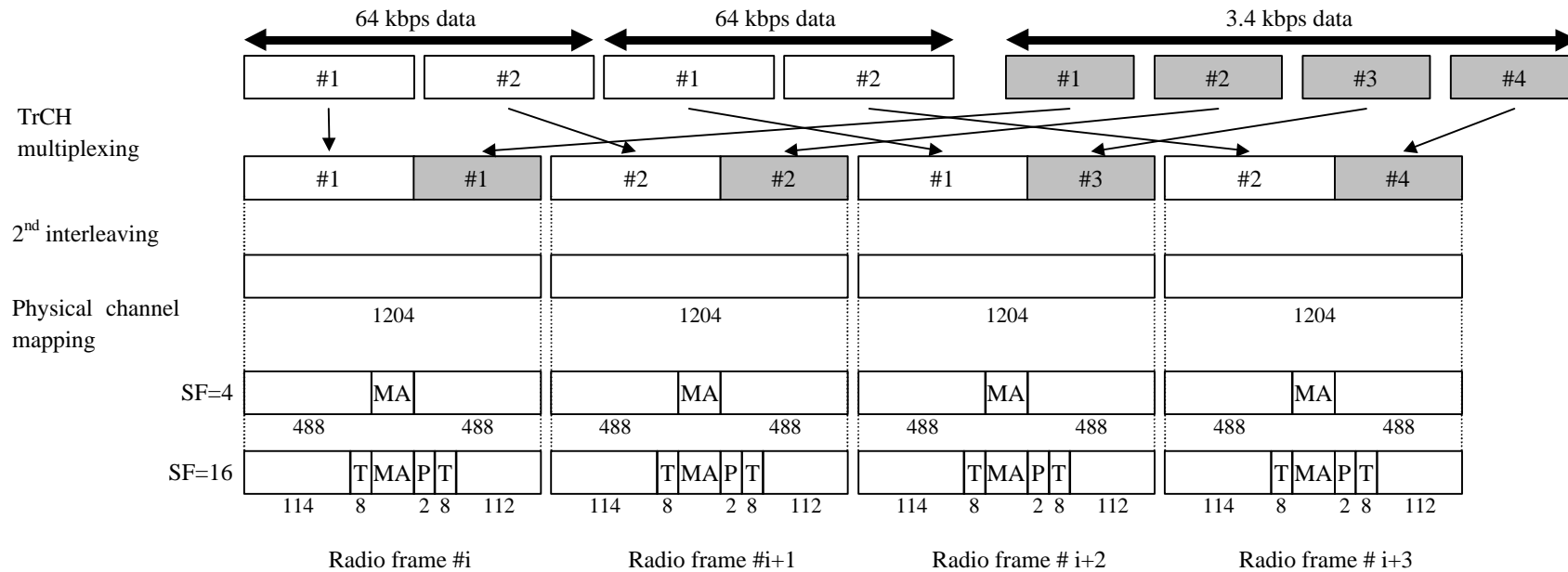

Figure 35: Channel coding and multiplexing example for multiplexing of 64 kbps packet data and 3.4 kbps data

Table 31: Physical channel parameters for multiplexing of 64 kbps packet data and 3.4 kbps data

Midamble	512 chips
Codes & time slots	$\{(SF16 \times 1 \text{ code}) + (SF4 \times 1 \text{ code})\} \times 1 \text{ time slot}$
TFCI	16 bits per user
TPC	2 bit

NOTE: As an additional example, physical channels can also be mapped without using multicode per timeslot, e.g.

for 64kbps:  $(SF16 \times 1 \text{ code} \times 1 \text{ timeslot}) + (SF4 \times 1 \text{ code} \times 1 \text{ timeslot})$

for 64kbps:  $(SF2 \times 1 \text{ code} \times 1 \text{ timeslot})$