

Agenda item: AH 14
Source: SAMSUNG Electronics Co., Philips
Title: Enhanced CPCH with Channel Assignment
Document for: Decision

1. Introduction

Common Packet Channel (CPCH) has been proposed and adopted as a working assumption for the efficient packet communication over uplink common channels [1, 2]. There have been many discussions related to the CPCH procedure. During the discussions, some inefficiency of the DCH/CPCH resource usage with current CPCH procedure has been pointed out and a couple of proposals to enhance the efficiency has been proposed [3, 4].

The inefficiency mainly comes from the resource allocation scheme in current CPCH procedure, that is, the UE determines the DCH/CPCH pair number and UTRAN does not have the ability to schedule the DCH/CPCH resource. In the current scheme, UTRAN can only send ACK or NAK for the transmission of CPCH that the mobile selects. Therefore, it is possible that CPCH cannot be assigned even if UTRAN has available resources.

In this paper, we propose a new CPCH procedure to enhance the resource usage efficiency in CPCH scheme. In the proposed CPCH procedure, the UTRAN decides the resource allocation for the DCH/CPCH pair and therefore achieve maximum efficiency in CPCH related resource usage. We also present the detailed channel assignment structure and the performance result with proposed scheme.

2. Current CPCH procedure

2.1 Current CPCH Procedure

The current CPCH procedures are showed in Figure 1. According to current working assumption in [1], the characteristics of CPCH procedure can be summarised as follows.

- UE determines the DCH/CPCH pair number for burst data transmission by selecting AP and CD preamble.

- UTRAN can decide only the ACK or NAK according to its resource occupancy status for the requested DCH/CPCH pair number.
- There is no freedom for UTRAN to manage the DCH/CPCH channel resource in the present scheme.

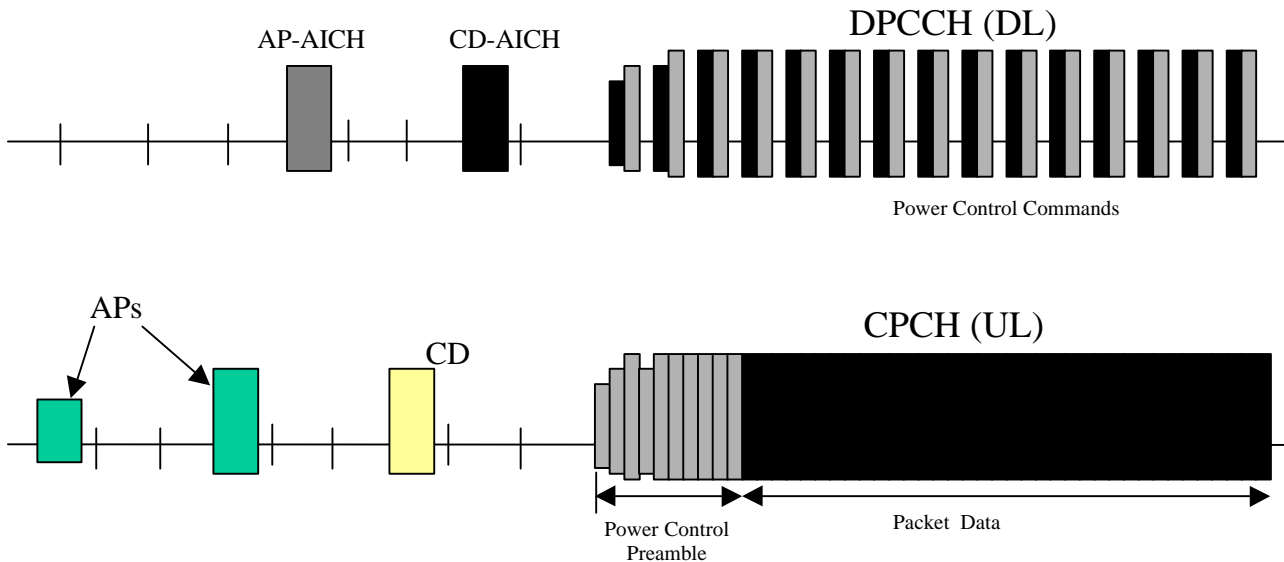

Figure 1. Current CPCH Procedure

2.2 Problem in Current CPCH Related Resource Allocation Schemes.

The main reason for the inefficiency can be summarised as follows.

- If UE chooses the DCH/CPCH pair randomly and UTRAN can only send an ACK/NCK for this, the blocking probability increases when there are many occupied CPCH channels in the reverse link. If the DCH/CPCH pair that the UE chooses is already used by other UE, UTRAN cannot assign other channel resources to the UE even though there are other channel resources available. This happens more frequently as the number of used CPCH increases in the reverse link and degrades the efficiency of CPCH utilisation.
- Above problem is due to the fact that UTRAN cannot allocate the CPCH related resources to the UE's

3. Enhanced CPCH procedure

3.1 Proposed CPCH Procedure

Figure 2 shows the proposed CPCH procedure. This is described here in outline. Some parameters, for example, the maximum number of re-transmissions may need to be defined in addition.

- (1) UE sends the acquisition preamble that is similar to RACH preamble. In the case of CPCH's with different bit rates being available, there may be a defined mapping between preambles and CPCH bit rates.
- (2) Detecting the acquisition preamble that UE sent, UTRAN decides the ACK or NAK according to the loading condition of reverse link and the UTRAN resource occupancy status of DCH/CPCH pairs. Then, UTRAN sends the ACK/NAK through AP-AICH.
 - ACK : one or more DCH/CPCH pairs are available and can be assigned to the UE
 - NAK : currently no DCH/CPCH pair is available for the UE
- (3) UE detects the AP-AICH and does as follows depending on the detected AP-AICH.
 - If no signal is detected in the AP-AICH, UE waits a time period $\tau_{P,P}$ and send the AP with increased power.
 - If NAK is received from the AP-AICH, UE stops transmission and waits some time periods and begins new CPCH procedure from (1).
 - If ACK is received from the AP-AICH, UE continue the CPCH procedure of (4).
- (4) UE selects a CD signature and transmit the CD preamble to the base station.
- (5) UTRAN detects the CD preamble and sends back the CD signature in CD-AICH. At the same time, UTRAN sends the DCH/CPCH pair number through Channel Assignment AICH (CA-AICH) to indicate the channel number to be used for CPCH. The channel assignment is sent in the signature form as used in AICH. Up-link CPCH and DCH for the CPCH are one-to-one mapped and can be assigned by assigning only DCH.
- (6) UE detects the CD-AICH and CA-AICH. If the returned CD signature does not match the original one, UE stops transmission and begins a new CPCH procedure. If the returned CD number matches to the signature that UE sent in the CD preamble, UE receives the CA signature and starts to transmit the burst data through the assigned CPCH while controls its transmit power according to PCB from the DCH.

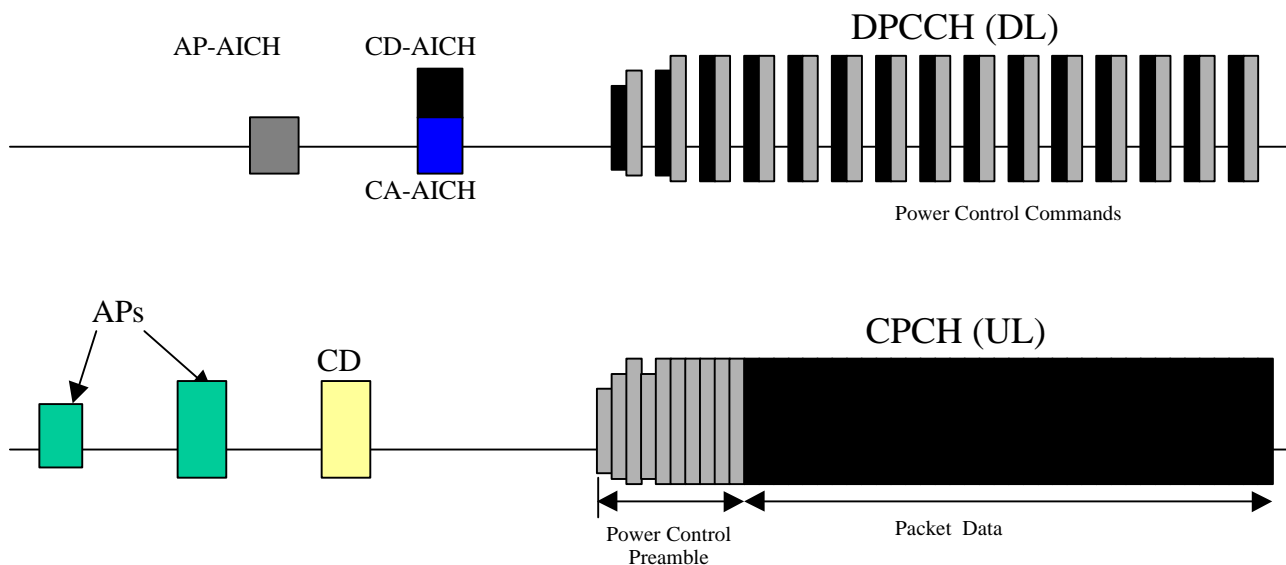

Figure 2 Proposed CPCH Procedure

3.2 Signature mapping for CD-AICH and CA-AICH

Almost nothing has been discussed for the CA-AICH signature. In [5], it was proposed to use the currently defined RACH/AICH signatures (orthogonal Gold code) for CA-AICH. But, there is a basic difference in assumption between AP-AICH and CA-AICH. In case of AP-AICH (for RACH), UTRAN returns the signature that UE sent in the access preamble. Therefore, UE knows which signature will be returned and needs to detect only one signature that UE sent in the RACH preamble.

In case of CA-AICH, UTRAN can send one signature among multiple and UE doesn't know which signature UTRAN will send. So, UE should detect multiple signatures to get the channel assignment information. This can increase UE receiver complexity. So, an efficient signature structure is necessary to reduce the computation and complexity of UE.

We propose to use Hadamard function for CA-AICH signature instead of Orthogonal Gold code. Table 1 shows the proposed CD/CA-AICH signature. If 8 signatures are assigned for CD-AICH (can be extended to 16 by multiplication by +1 or -1), then up to 8 signatures can be assigned for the CA-AICH and the +1/-1 sign can be used to indicate up to 16 CPCH related resource allocations. This mapping avoids the possible need to transmit a signature and its inverse at the same time.

i	W_I															
1	A	A	A	A	A	A	A	A	A	A	A	A	A	A	A	A
2	A	-A	A	-A	A	-A	A	-A	A	-A	A	-A	A	-A	A	-A
3	A	A	-A	-A	A	A	-A	-A	A	A	-A	-A	A	A	-A	-A
4	A	-A	-A	A	A	-A	-A	A	A	-A	-A	A	A	-A	-A	A
5	A	A	A	A	-A	-A	-A	-A	A	A	A	A	-A	-A	-A	-A
6	A	-A	A	-A	-A	A	-A	A	A	-A	A	-A	-A	A	-A	A
7	A	A	-A	-A	-A	-A	A	A	A	A	-A	-A	-A	-A	A	A
8	A	-A	-A	A	-A	A	A	-A	A	-A	-A	A	-A	A	A	-A
9	A	A	A	A	A	A	A	A	-A	-A	-A	-A	-A	-A	-A	-A
10	A	-A	A	-A	A	-A	A	-A	-A	A	-A	A	-A	A	-A	A
11	A	A	-A	-A	A	A	-A	-A	-A	-A	A	A	-A	-A	A	A
12	A	-A	-A	A	A	-A	-A	A	-A	A	A	-A	-A	A	A	-A
13	A	A	A	A	-A	-A	-A	-A	-A	-A	-A	-A	A	A	A	A
14	A	-A	A	-A	-A	A	-A	A	-A	A	-A	A	A	-A	A	-A
15	A	A	-A	-A	-A	-A	A	A	-A	-A	A	A	A	A	-A	-A
16	A	-A	-A	A	-A	A	A	-A	-A	A	A	-A	A	-A	-A	A

Table 1. Proposed CD/CA-AICH signature.

The proposed signature is designed to reduce the complexity of UE by FHT (Fast Hadamard Transform). One important thing is that CA-AICH doesn't use all the signatures. In that case, the complexity of UE can be decrease further by an efficient signature selection. For example, UTRAN can support 4, 8, 16 CPCH's. In that case, the system may need only 2, 4, 8 signature. The order that assigns the signature to CPCH is as follows

- [S1, S9] up to 2 signatures
- [S1, S5, S9, S13] up to 4 signatures
- [S1, S3, S5, S7, S9, S11, S13, S15] up to 8 signatures

For example, following signatures are assigned when 4 signatures are assigned for CPCH.

- A A A A A A A A A A A A A A A A (Signature 1)
- A A A A -A -A -A -A A A A A -A -A -A -A (Signature 5)
- A A A A A A A A A -A -A -A -A -A -A -A -A (Signature 9)
- A A A A -A -A -A -A -A -A -A -A A A A A (Signature 13)

Looking above signatures, it can be observed that the symbols are repeated 4 times. So, UE can use length 4 FHT after adding repeated 4 symbols. By using the property of repetition, UE can decrease the complexity further.

A mapping between CD-AICH signature and the CD preamble is necessary. It is possible that only a portion of CD preamble is used. In that case, false detection probability of CD-AICH can be decreased a little by an efficient signature mapping. As an example, assume that only 2 CD preamble is used. Two possible signature mappings for two CD preamble are {S2, S4} and {S2, -S2}. The distance between signature S2 and S4 is 8 symbols while the distance between signature S2 and -S2 is 16. By assigning CD-AICH signature as {S2, -S2, S4, -S4, ...}, a potential gain can be achieved in terms of false detection probability.

3.3 Advantage of Proposed CPCH Procedure

- UTRAN can allocate and control the available resource for the CPCH. This scheme maximises resource usage efficiency.
- UE does not need to monitor the channel occupancy of each CPCH before the CPCH transmission, but the proposed procedure can easily be combined some possible form of monitoring of CPCH status.

4. Conclusions

In this paper, we proposed a new CPCH procedure for enhanced resource allocation. A Channel Assignment AICH (CA-AICH) is transmitted with the CD-AICH. UTRAN can assign the DCH/CPCH pair to the UE by transmitting a signature that is mapped to DCH/CPCH pair. With this scheme we can maximise the efficiency of CPCH.

References

- [1] GBT/ Tdoc 592: CPCH physical layer procedures
- [2] GBT/Tdoc 594: Overview of System-wide CPCH Access procedures
- [3] Interdigital Comm. Corp./Tdoc816: CPCH Channel Allocation
- [4] Samsung Electronics Co./Tdoc906: Enhanced CPCH Procedure
- [5] Philips/TdocABC: Enhanced CPCH with status monitoring and code assignment

(contact) Hichan Moon (Samsung), E-mail: hcmoon@telecom.samsung.co.kr

Tim Mouldsley (Philips), Email: mouldsley@prl.research.philips.com