

Changes to CR 071 in TP-040049 (T2-040123)

CR-Form-v7

CHANGE REQUEST

⌘ **23.040 CR 071** ⌘ rev **1** ⌘ Current version: **6.2.0** ⌘

For **HELP** on using this form, see bottom of this page or look at the pop-up text over the ⌘ symbols.

Proposed change affects: UICC apps ME Radio Access Network Core Network

| | | | |
|--|---|--|---|
| Title: | ⌘ Procedure for confirming the existence of an SMS interworking agreement | | |
| Source: | ⌘ T2 | | |
| Work item code: | ⌘ TEI6 Date: ⌘ 19/02/2004 | | |
| Category: | ⌘ C Release: ⌘ Rel-6 | | |
| | <table border="0"> <tr> <td style="vertical-align: top;"> <p><i>Use <u>one</u> of the following categories:</i></p> <p>F (correction)</p> <p>A (corresponds to a correction in an earlier release)</p> <p>B (addition of feature),</p> <p>C (functional modification of feature)</p> <p>D (editorial modification)</p> <p>Detailed explanations of the above categories can be found in 3GPP TR 21.900.</p> </td> <td style="vertical-align: top; padding-left: 20px;"> <p><i>Use <u>one</u> of the following releases:</i></p> <p>2 (GSM Phase 2)</p> <p>R96 (Release 1996)</p> <p>R97 (Release 1997)</p> <p>R98 (Release 1998)</p> <p>R99 (Release 1999)</p> <p>Rel-4 (Release 4)</p> <p>Rel-5 (Release 5)</p> <p>Rel-6 (Release 6)</p> </td> </tr> </table> | <p><i>Use <u>one</u> of the following categories:</i></p> <p>F (correction)</p> <p>A (corresponds to a correction in an earlier release)</p> <p>B (addition of feature),</p> <p>C (functional modification of feature)</p> <p>D (editorial modification)</p> <p>Detailed explanations of the above categories can be found in 3GPP TR 21.900.</p> | <p><i>Use <u>one</u> of the following releases:</i></p> <p>2 (GSM Phase 2)</p> <p>R96 (Release 1996)</p> <p>R97 (Release 1997)</p> <p>R98 (Release 1998)</p> <p>R99 (Release 1999)</p> <p>Rel-4 (Release 4)</p> <p>Rel-5 (Release 5)</p> <p>Rel-6 (Release 6)</p> |
| <p><i>Use <u>one</u> of the following categories:</i></p> <p>F (correction)</p> <p>A (corresponds to a correction in an earlier release)</p> <p>B (addition of feature),</p> <p>C (functional modification of feature)</p> <p>D (editorial modification)</p> <p>Detailed explanations of the above categories can be found in 3GPP TR 21.900.</p> | <p><i>Use <u>one</u> of the following releases:</i></p> <p>2 (GSM Phase 2)</p> <p>R96 (Release 1996)</p> <p>R97 (Release 1997)</p> <p>R98 (Release 1998)</p> <p>R99 (Release 1999)</p> <p>Rel-4 (Release 4)</p> <p>Rel-5 (Release 5)</p> <p>Rel-6 (Release 6)</p> | | |

| | |
|-----------------------------|---|
| Reason for change: ⌘ | <p>Operators that do not have a reciprocal commercial agreement for SMS interworking, such as the SMS interworking agreement defined by GSM-A, may want to control SMS traffic flow between their respective networks. However, this is not always possible when the terminating operator is based in a country that provides mobile number portability (MNP). An originating operator from outside a portability cluster is unable to determine whether the terminating UE has been ported out from a terminating Operator with which the originating operator has an SMS interworking agreement, to another Operator with which the originating operator has no commercial SMS interworking agreement. The current specification does not specify any procedures for controlling SMS traffic in such a case. Operators prefer to guard short messages before they are submitted to SC rather than after submission in order to avoid the SC having to handle undeliverable short messages and to allow a failure report to be send to the originating UE.</p> |
| Summary of change: ⌘ | <p>SMS-IWMSC/GMSC sends the MAP_SendRoutingInforForSM (SRIforSM) in Short Message mobile originated procedure when the terminated UE is in a country that provides Mobile Number Portability. <u>In other words, SMS-IWMSC may retrieve the MSISDN from TPDU in order to interrogate the HLR.</u> This procedure ensures that the IMSI for the terminated UE can be identified. The SMS-IWMSC/GMSC uses the IMSI to check whether the operator to which the terminated UE subscribes has an SMS interworking agreement. If the existence of an SMS interworking agreement is confirmed, then the Short message mobile originated procedure will be successful. If not, the procedure will fail.</p> |

Consequences if not approved: ☼ SMS traffic cannot be blocked even though the originating operator does not want to transfer SMS to an operator with which it has no commercial SMS interworking agreement.

Clauses affected: ☼ 5.2.2, 8.2.2, 9, 10.2, 11.3

Other specs affected:

| Y | N |
|---|---|
| | X |
| | X |
| | X |

☼ Other core specifications ☼
☼ Test specifications ☼
☼ O&M Specifications ☼

Other comments: ☼ GSM-A IREG requests to standarize the solution of checking an SMS interworking agreement.
This procedure is ~~applied when the SMS-GMSC is integrated with the SMS-WMSC, and~~ considered smaller impact so that no stage 3 work is needed.

***** First modified section *****

5.2 Routing requirements

5.2.1 Mobile terminated short message

The SC sends the short message to the SMS-GMSC. The SMS-GMSC interrogates the HLR to retrieve routing information necessary to forward the short message, and then sends the message to the relevant MSC or SGSN, transiting other networks if necessary. The MSC or SGSN then sends the short message to the MS.

5.2.2 Mobile originated short message

The MS sends the short message to the MSC or the SGSN. The MS shall always address the required SC by an E.164 [17] address. The visited PLMN shall route the message to the appropriate SMS-IW MSC in the SC's PLMN, transiting other networks if necessary.

As an operator option, the SMS-GIWMSC may interrogate the HLR to retrieve the recipient's IMSI in order to check that an SMS Interworking agreement, exists between the two networks. It is noted that this optional procedure is applied when the SMS-GMSC is integrated with the SMS-IW MSC.

***** Second modified section *****

8.2 Node functionality related to SM MO

8.2.1 Functionality of the MSC

When receiving a short message TPDU from the MS, the MSC is responsible for the following operations:

- reception of the short message TPDU (see 3GPP TS 24.011 [13]);
- retrieving information from the VLR ("sendInfoForMO-SMS", see clause 10); the MSISDN of the MS and, when appropriate, error information. The retrieval of information from the VLR is followed by the VLR investigating the MNRF (to be used in the alerting procedure, see clause 10)

if errors are indicated by the VLR:

- returning the appropriate error information to the MS in a failure report (negative outcome of "sendInfoForMO-SMS" see clauses 10 and 11);

if no errors are indicated by the VLR:

- inspection of the RP-DA parameter;

if parameters are incorrect:

- returning the appropriate error information to the MS in a failure report (see 3GPP TS 24.011 [13]);

if no parameter errors are found:

NOTE: The SMS-IW MSC may be identical to the MSC.

- transferring the short message TPDU to the SMS-IW MSC ("forwardShortMessage", see clause 10).

When receiving the report of the short message from the SMS-IWMSC (positive or negative outcome of the "forwardShortMessage", see clause 10), the MSC is responsible for the following operations:

- relaying the report to the MS (see 3GPP TS 24.011 [13]).

8.2.2 Functionality of the SMS-IWMSC

When receiving a short message TPDU from the MSC or SGSN ("forwardShortMessage", see clause 10), the SMS-IWMSC is responsible for the following operations:

- reception of the short message TPDU;
- optionally, interrogating the HLR ("sendRoutingInfoForShortMsg", see clause 10); retrieving the recipient's IMSI in order to check for the existence of an SMS Interworking agreement before establishing a link with the addressed SC;

if HLR returns error information:

- returning the appropriate error information to the MSC or SGSN in a failure report (negative outcome of "forwardShortMessage", see clause 10);

if no errors are indicated by the HLR:

- inspecting the IMSI parameter and ignoring the other routing information;

if the received parameter is unacceptable to the SMS-IWMSC (due to lack of an SMS Interworking agreement):

- returning SM Delivery Failure with indication: invalid SME-address to the MSC or SGSN;

if the parameter is acceptable to the SMS-IWMSC (due to the existence of an SMS Interworking agreement) or the SMS-IWMSC didn't apply the optional HLR interrogation:

- establishing, where necessary, a link with the addressed SC (see clause 5);
- transferring the short message TPDU to the SC (if the address is valid).

If a report associated with the short message is received from the SC, the SMS-IWMSC is responsible for the following operations:

- relaying of the report to the MSC or SGSN (positive or negative outcome of "forwardShortMessage", see clause 10).

If a report associated with the short message is not received from the SC before a timer expires or if the SC address is invalid, the SMS-IWMSC is responsible for the following operations:

- returning the appropriate error information to the MSC or SGSN in a failure report (negative outcome of "forwardShortMessage", see clause 10).

The value of the timer is dependent on the protocol between the SC and the SMS-IWMSC.

8.2.3 Functionality of the SGSN

When receiving a short message TPDU from the MS, the SGSN is responsible for the following operations:

- reception of the short message TPDU (see 3GPP TS 24.011 [13]);
- inspection of the RP-DA parameter;

if parameters are incorrect:

- returning the appropriate error information to the MS in a failure report (see 3GPP TS 24.011 [13]);

if no parameter errors are found:

- transferring the short message TPDU to the SMS-IWMSC ("forwardShortMessage", see clause 10).

When receiving the report of the short message from the SMS-IWMSC (positive or negative outcome of the "forwardShortMessage", see clause 10), the SGSN is responsible for the following operations:

- relaying the report to the MS (see 3GPP TS 24.011 [13]).

8.2.x — Functionality of the SMS-IWMSC/GMSC

When receiving a short message TPDU from the MSC or SGSN ("forwardShortMessage", see clause 10), the SMS-IWMSC/GMSC is optionally responsible for the following operations

— interrogating the HLR ("sendRoutingInfoForShortMsg", see clause 10); retrieving the recipient's IMSI in order to check for the existence of an SMS Interworking agreement before establishing a link with the addressed SC;

if HLR returns error information:

— returning the appropriate error information to the MSC or SGSN in a failure report (negative outcome of "forwardShortMessage", see clause 10);

if no errors are indicated by the HLR:

— inspecting the IMSI parameter and ignoring the other routing information;

if the received parameter is unacceptable to the SMS-IWMSC/GMSC (due to lack of an SMS Interworking agreement):

— returning the appropriate error information to the MSC or SGSN in a failure report (negative outcome of "forwardShortMessage", see clause 10);

if the parameter is acceptable to the SMS-IWMSC/GMSC (due to the existence of an SMS Interworking agreement):

— establishing, where necessary, a link with the addressed SC (see clause 5);

— transferring the short message TPDU to the SC (if the address is valid);

The operations after transferring the short message TPDU to the SC are same as the functionality of the SMS-IWMSC (see clause 8.2.2);

***** Third modified section *****

9 Protocols and protocol architecture

The protocol layers of the SMS are structured as shown in figure 7.

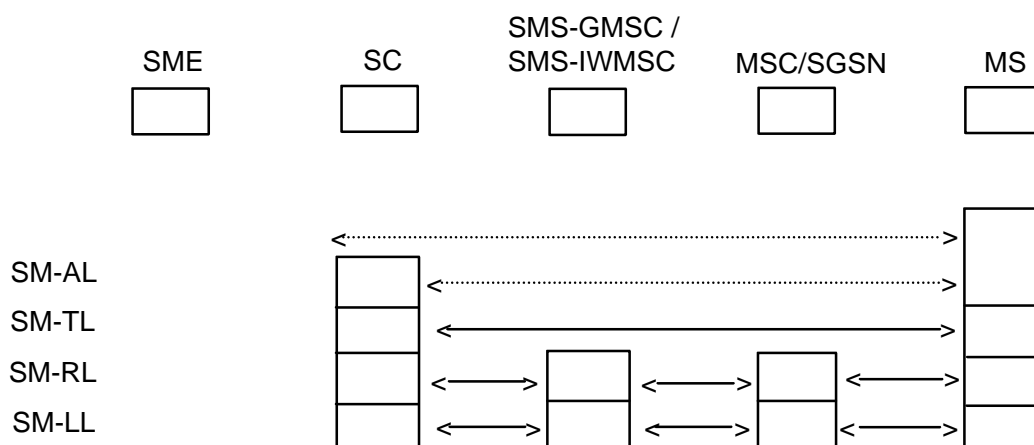

Figure 7: Protocol layer overview for the Short Message Service

The present document specifies the protocol at the SM-TL, the service offered by the SM-TL at the MS and the SC, and the service offered by the SM-RL at the SC.

Note that while normally SM-TL terminates at the SC in SM MO, the SMS-IWMSC may inspect TP-DA in SMS-SUBMIT for the purpose of checking the existence of an ~~an~~ SMS interworking agreement (see clause 8.2.2).

****** Fourth modified section ******

10.2 Short message mobile originated

The entities involved in this procedure is depicted in figure 17.

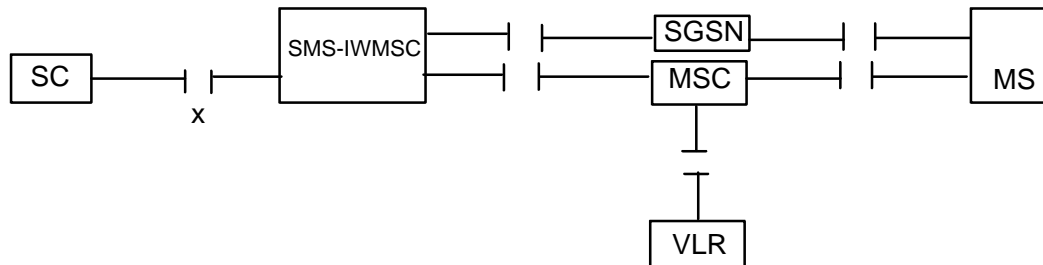

Figure 17: Interfaces involved in the Short message mobile originated procedure

GSM TS 43.002 [5]. X is the interface between an MSC or an SGSN and an SC as defined in clause 5.

Note that since the short message mobile originated procedure covers the functionality required at SM-RL for transferring TPDU from SC to MS, the procedure described covers both short message (SMS-SUBMIT) and command (SMS-COMMAND) transfer. The term "short message transfer" therefore in this clause, covers both cases.

In figure 18, sequence diagrams for the following basic situations of short message mobile terminated transfer attempt:

- Successful short message transfer;
- Short message transfer attempt failing due to error at the MSC or SGSN;
- Short message transfer attempt failing due to negative outcome of VLR information retrieval;
- Short message transfer attempt failing due to error at the SMS-IWMSC;
- Short message transfer attempt failing due to error at the SC.
- [Short Message transfer attempt Successful due to the existence of an SMS Interworking agreement](#)
- [Short Message transfer attempt failing due to non-existence of an SMS Interworking agreement.](#)
- [Short Message transfer attempt failing due to negative outcome of HLR information retrieval.](#)

References to the relevant specifications of the different operations are given in clause 4.

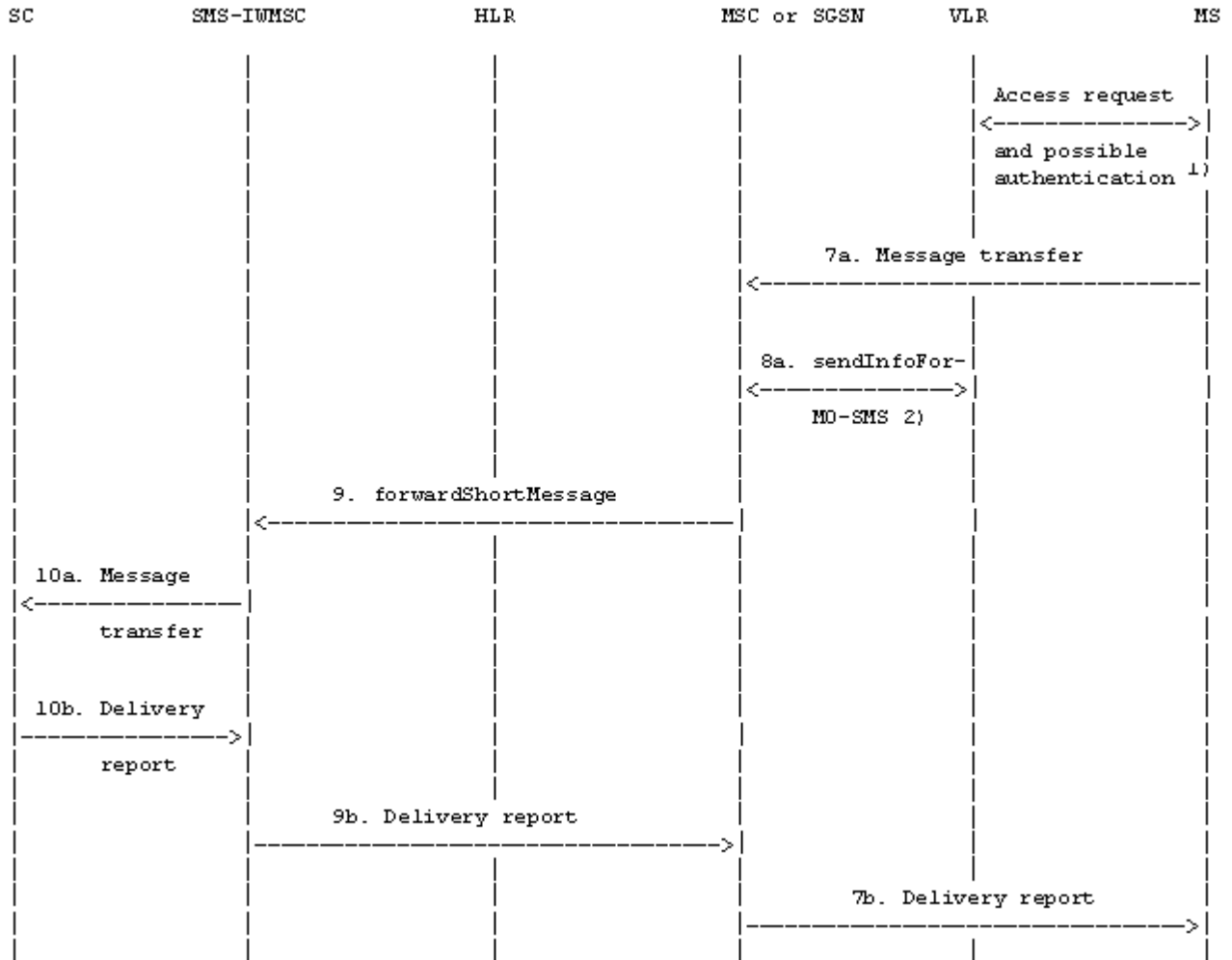

→ : Operation invocation or message transfer
 ↔ : Successful operation invocation or message transfer including report

NOTE 1): Described in [12] and 3GPP TS 29.002 [15].

NOTE 2): This operation is not used by the SGSN.

Figure 18a): Successful short message transfer attempt

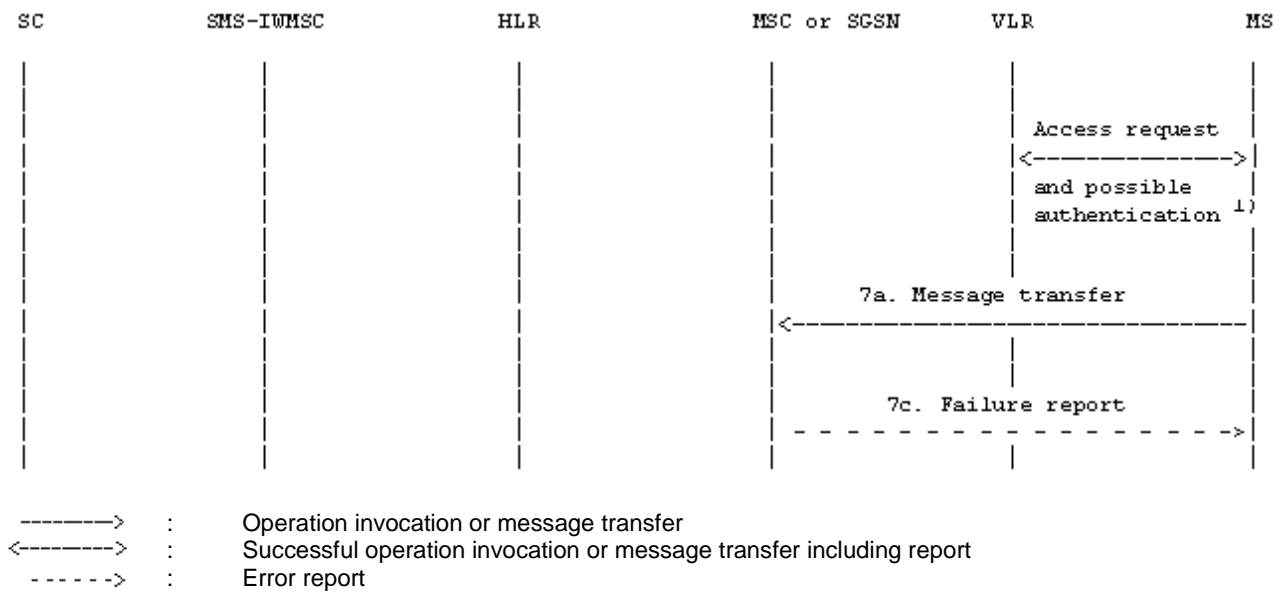

NOTE 1): Described in GSM 44.008 [12] and 3GPP TS 29.002 [15].

Figure 18b): Short message transfer attempt failing due to error at the MSC or SGSN

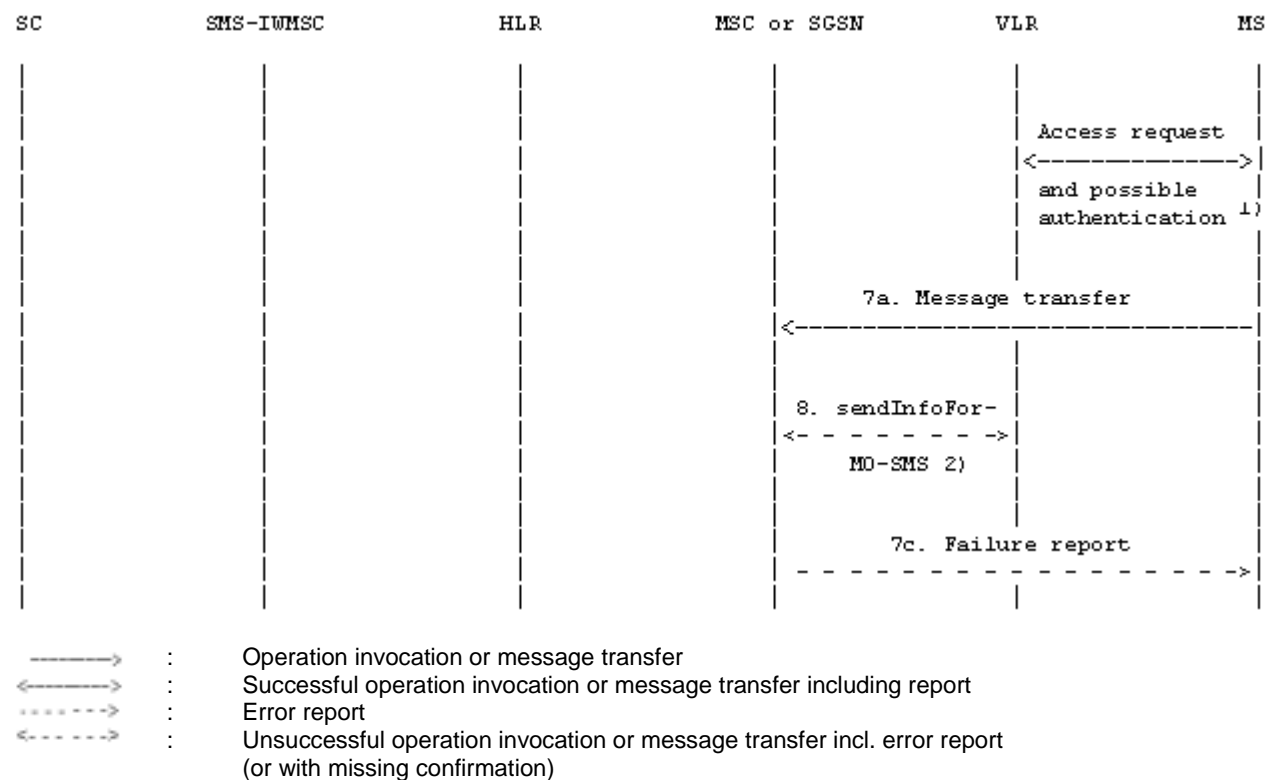

NOTE 1): Described in GSM 44.008 [12] and 3GPP TS 29.002 [15].

NOTE 2): This operation is not used by the SGSN.

Figure 18c): Short message transfer attempt failing due to negative outcome of VLR information retrieval

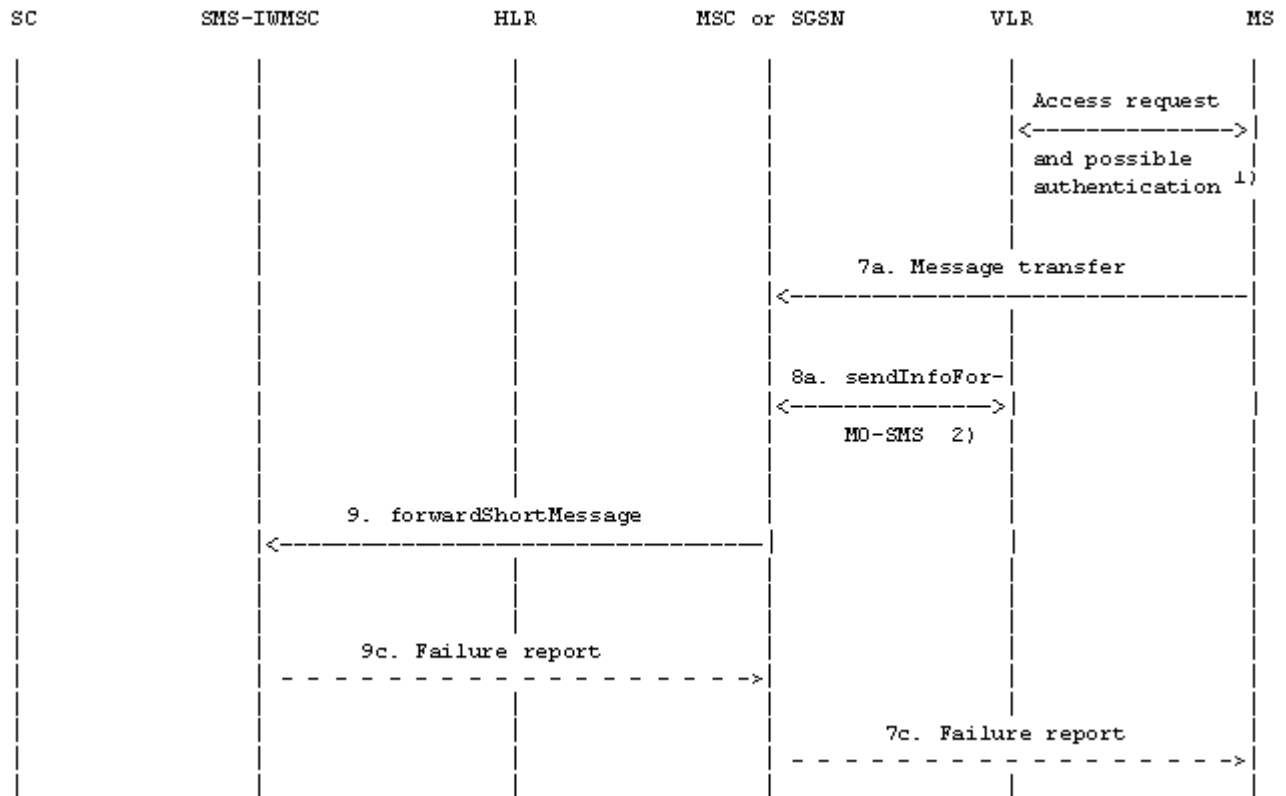

- > : Operation invocation or message transfer
- <-----> : Successful operation invocation or message transfer including report
- - - - -> : Error report

NOTE 1): Described in GSM 44.008 [12] and 3GPP TS 29.002 [15].

NOTE 2): This operation is not used by the SGSN.

Figure 18d): Short message transfer attempt failing due to error at the SMS-IW MSC

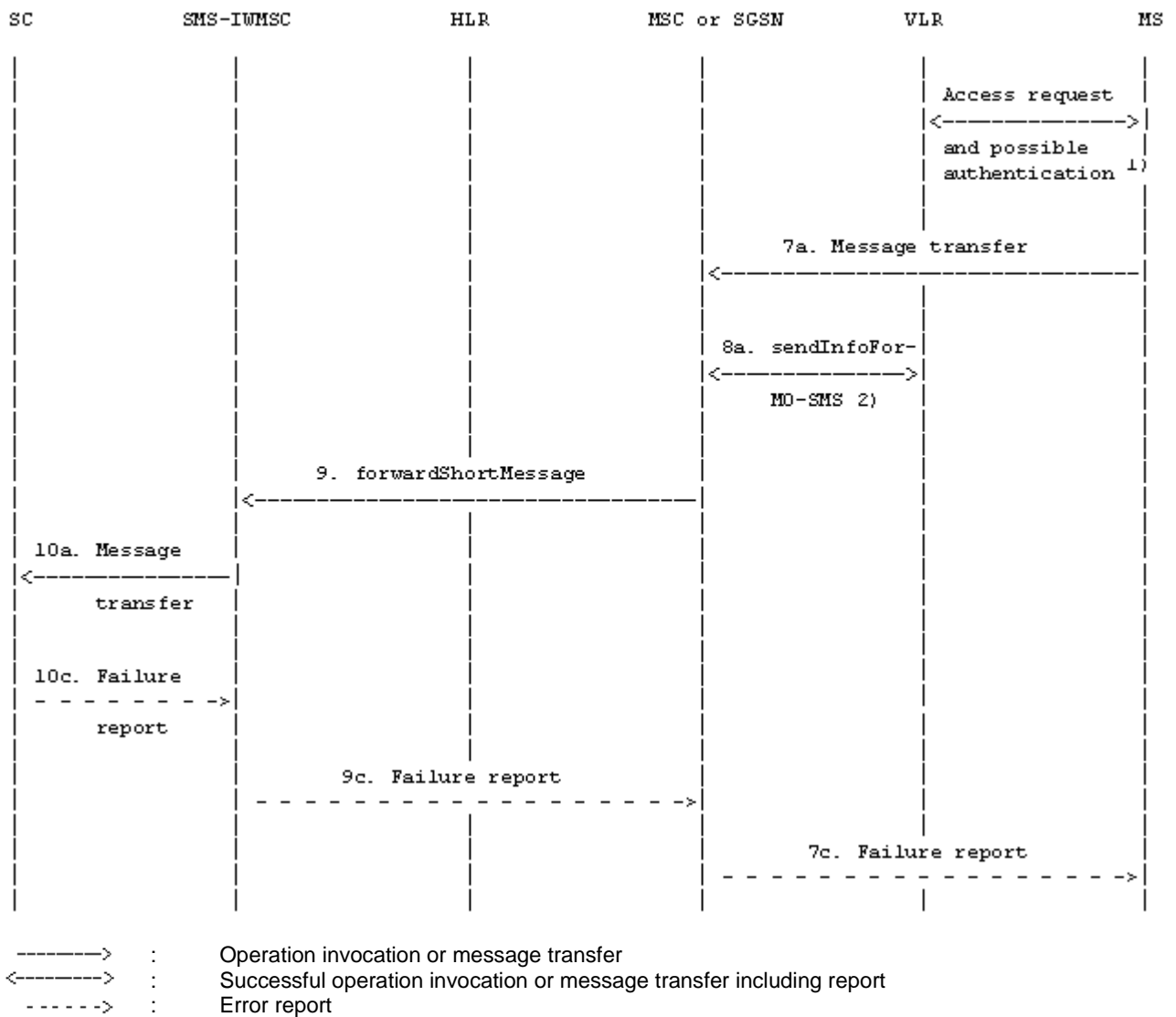

NOTE 1): Described in GSM 44.008 [12] and 3GPP TS 29.002 [15].

NOTE 2): This operation is not used by the SGSN.

Figure 18e): Short message transfer attempt failing due to error at the SC

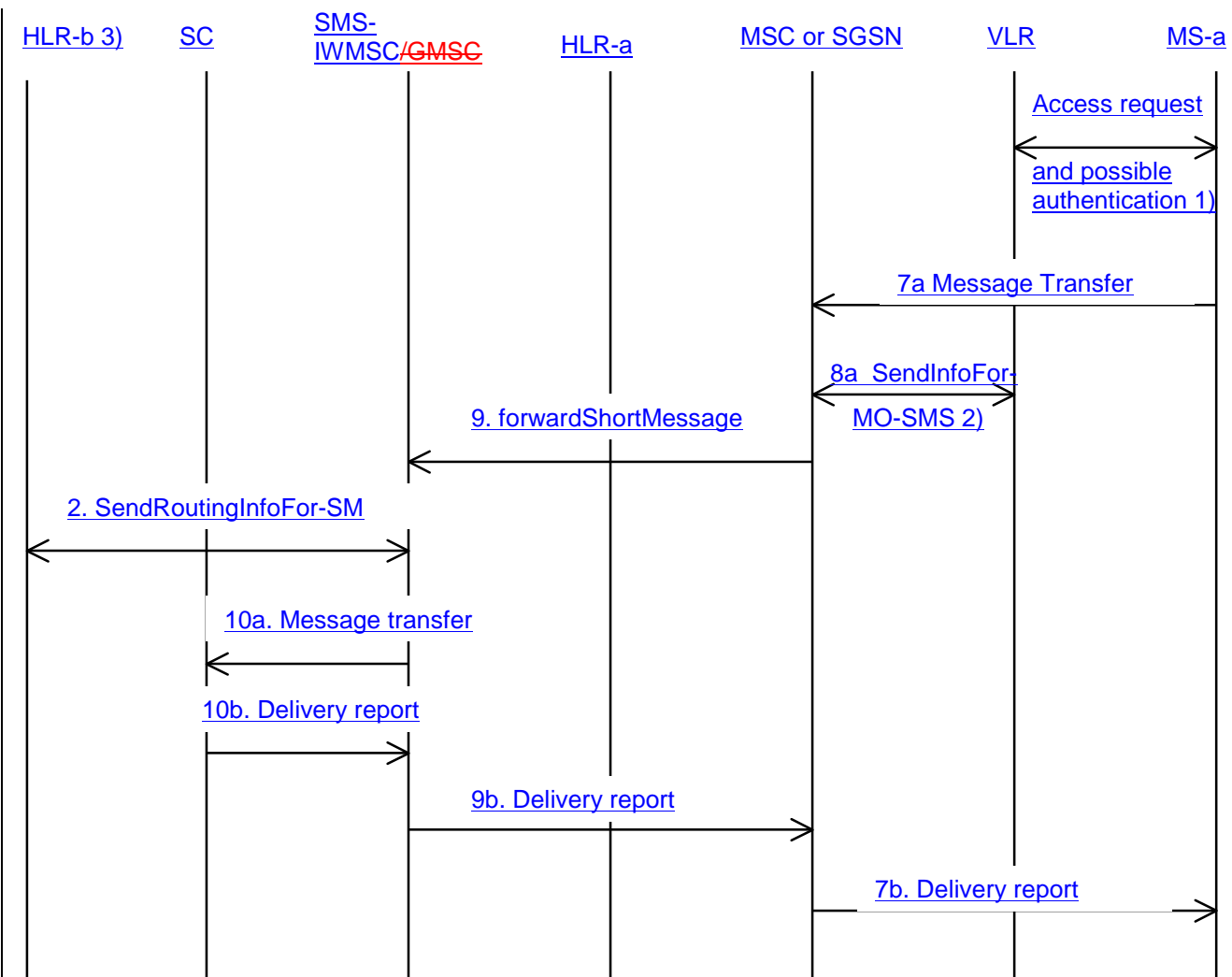

→ : Operation invocation or message transfer
 ← : Successful operation invocation or message transfer including report

NOTE 1): Described in TS 44.008 [12] and TS 29.002 [15].
 NOTE 2): This operation is not used by the SGSN.
 NOTE 3): HLR that terminated user belongs to.

After completing operation 2, SMS-IWMSC/GMSC could check whether SMS interworking agreement exists or not based on IMSI. In this figure 18f case, there is an SMS interworking agreement between operators.

Figure 18f): Short Message transfer Successful due to the existence of an SMS Interworking agreement

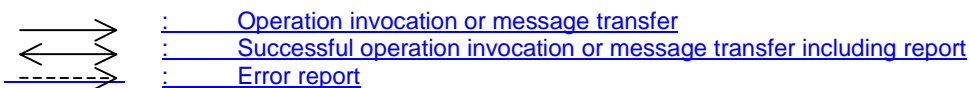
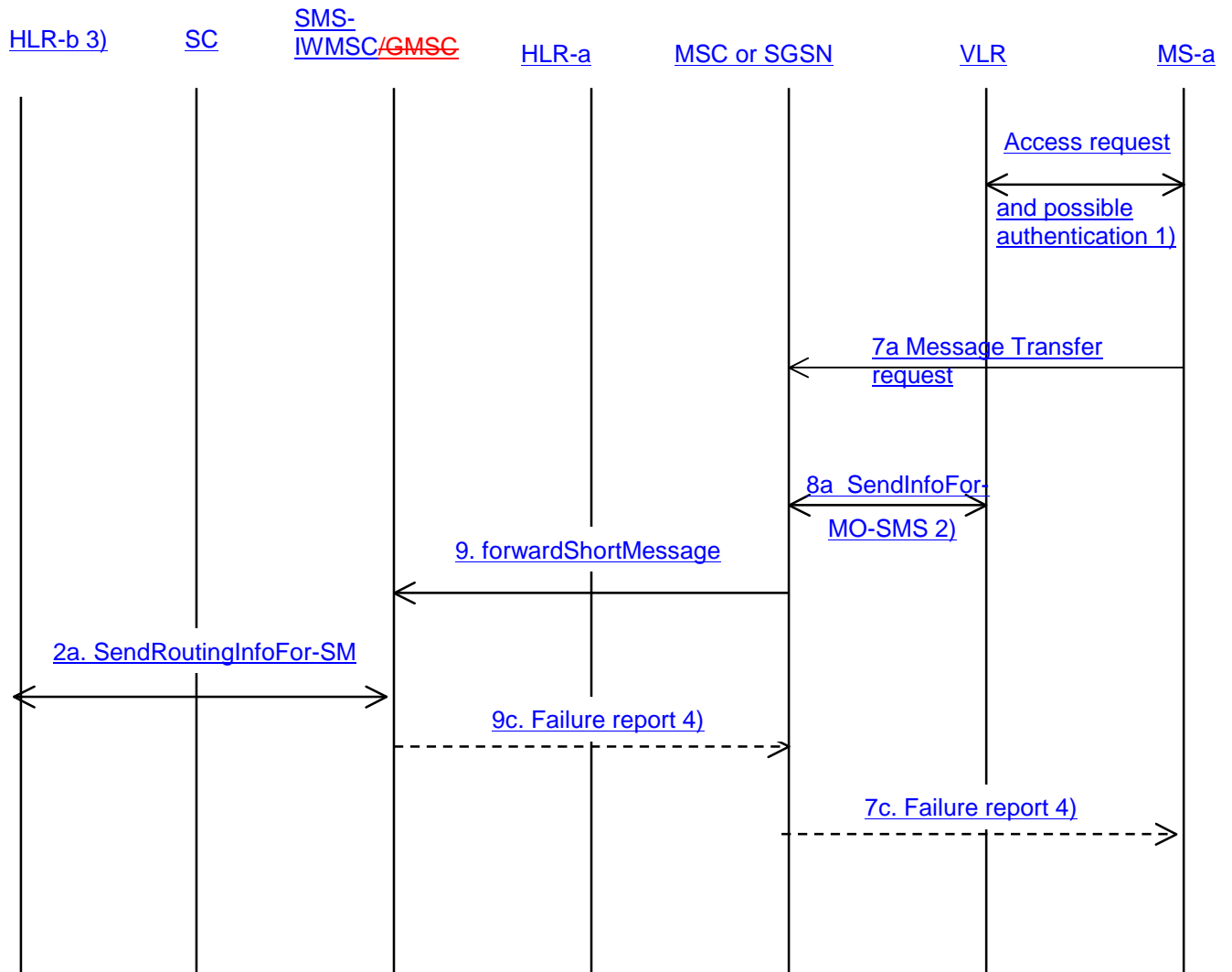

NOTE 1): Described in TS 44.008 [12] and TS 29.002 [15].

NOTE 2): This operation is not used by the SGSN.

NOTE 3): HLR that terminated user belongs to.

NOTE 4): The lack of an SMS interworking agreement can not be conveyed in the Failure Report as a specific indication.

After completing operation 2, SMS-IW MSC/GMSC could check whether SMS interworking agreement exists or not based on IMSI. In this figure18g case, there is no SMS Interworking agreement between operators.

Figure 18g): Short Message transfer attempt failing due to non-existence of an SMS Interworking agreement.

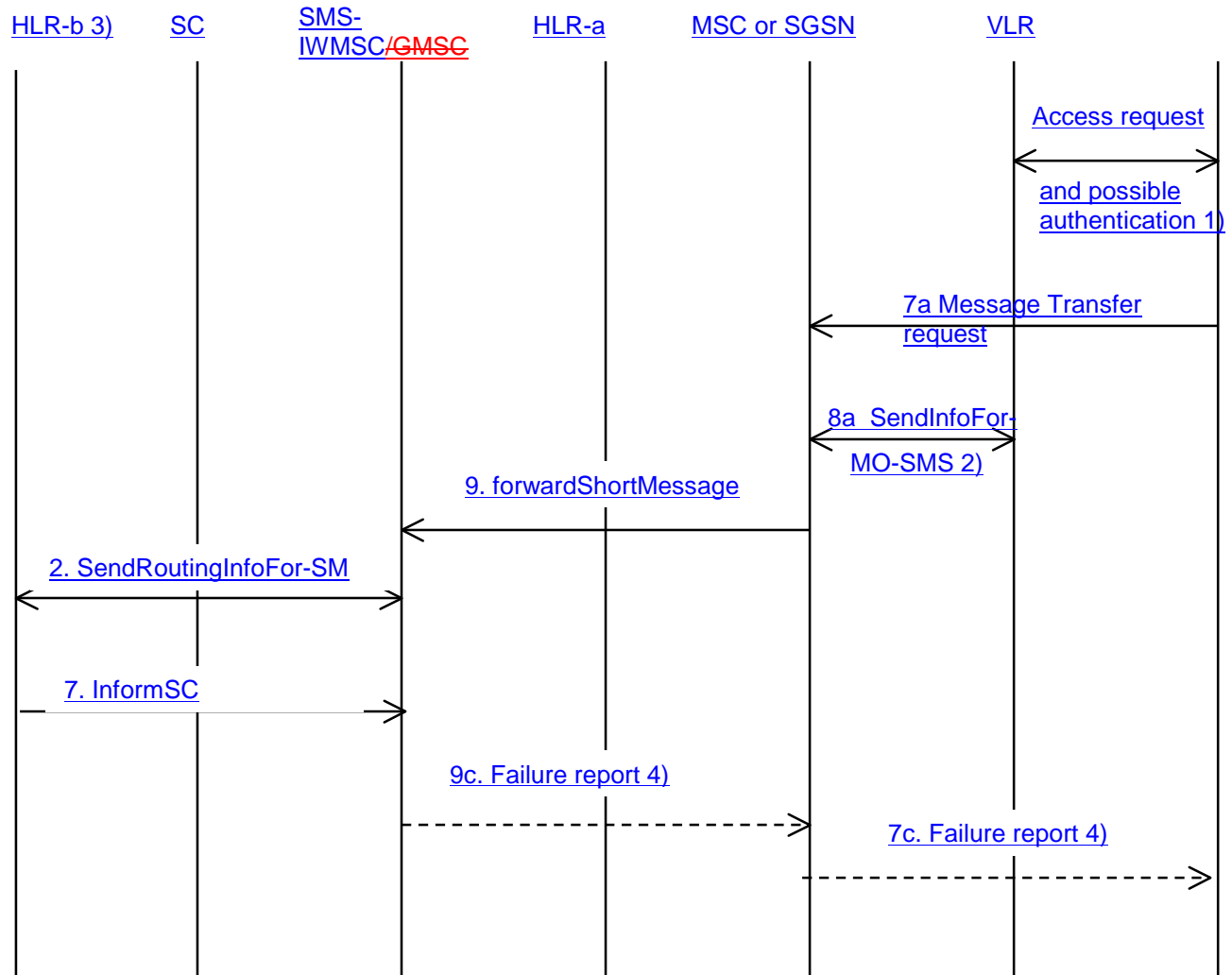

: Operation invocation or message transfer
 : Successful operation invocation or message transfer including report
 : Error report

NOTE 1): Described in TS 44.008 [12] and TS 29.002 [15].

NOTE 2): This operation is not used by the SGSN.

NOTE 3): HLR that terminated user belongs to.

NOTE 4): The lack of an SMS interworking agreement can not be conveyed in the Failure Report as a specific indication.

If SMS-IWMSC/GMSC receives an informSC Message, then this message shall be ignored by the SMS-IWMSC/GMSC.

Figure 18h: Short Message transfer attempt failing due to negative outcome of HLR information retrieval.

If a failure report is indicated by the HLR after invocation of the "sendRoutingInfoForShortMsg" operation, the SMS-IWMSC/GMSC shall return the appropriate error information to the MSC/SGSN with the error cause coded as specified in TS-29.002 [15] follows::

| <u>Return error from SendRoutingInfoForSM</u> | <u>Error mapping to ForwardShortMessage</u> |
|---|---|
| <u>system Failure</u> | <u>system Failure</u> |
| <u>data Missing</u> | <u>system Failure</u> |
| <u>Unexpected Data Value</u> | <u>system Failure</u> |
| <u>facility Not supported</u> | <u>SM Delivery Failure</u> |
| | <u>cause: invalid SME-address</u> |
| <u>unknown Subscriber</u> | <u>SM Delivery Failure</u> |
| | <u>cause: invalid SME-address</u> |
| <u>teleservice Not provisioned</u> | <u>SM Delivery Failure</u> |
| | <u>cause: invalid SME-address</u> |
| <u>Call barred</u> | <u>SM Delivery Failure</u> |
| | <u>cause: invalid SME-address</u> |
| <u>Absent Subscriber SM</u> | <u>SM Delivery Failure</u> |
| | <u>cause: invalid SME-address</u> |

Operation 2: sendRoutingInfoForShortMsg.

The operation is an interrogation of the HLR by the SMS-IWMSC/~~GMSC~~ to retrieve information necessary to forward the short message.

The outcome of the operation comprises either success, where the result contains the IMSI for terminated UE, or failure, which may be caused by several reasons.

Operation 7: Message transfer MS -> MSC or MS -> SGSN.

The operation is used to transfer a short message from the MS to the MSC or to the SGSN.

Operation 8: sendInfoForMO-SMS.

The operation provides a means for the MSC to verify from the VLR that the mobile originated short message transfer does not violate supplementary services invoked or restrictions imposed using the network feature Operator Determined Barring.

A successful VLR response carries the MSISdn of the originating MS being transferred to the SC at SM-RL.

NOTE: This operation is not used by SGSN.

Operation 9: forwardShortMessage.

The operation provides a means for the MSC or for the SGSN to transfer a short message to the SMS-IWMSC.

The procedure is required if the serving MSC or SGSN cannot access the SC directly, e.g. because it has no connection to SC (see clause 5).

The procedure works in tandem with the forwarding of the short message from the SMS-IWMSC to the SC. Thus, the outcome of the operation comprises either success, i.e. that the message has been delivered to the SC; or a failure that may be caused by several reasons, e.g. failure in the transfer MSC --> SMS-IWMSC or SGSN --> SMS-IWMSC, SC does not comply.

Operation 10: Message transfer SMS-IWMSC -> SC.

The operation is used to transfer a short message from an SMS-IWMSC to an SC, and consists of:

- the transfer of a message containing the TPDU from the SMS-IWMSC to the SC (see "10a. Message transfer" in figure 18); and
- the return of either a "Failure report" (see 10c. in figure 18) or a "Delivery report" (see 10b. in figure 18).

"Failure report" is returned to the MS when the SMS-IWMSC has received indication from the network or the SC that the procedure was unsuccessful.

****** Fifth modified section ******

11.3 Mobile Originated short message transfer

If errors are indicated by the VLR after invocation of the "sendInfoForMO-SMS" operation.(see clause 10), the MSC shall return the appropriate error information to the MS in a failure report (i.e. a RP-ERROR message) containing the following error cause:

| Return error from SendInfoForMO-SMS | Cause value in the RP-ERROR message |
|-------------------------------------|--------------------------------------|
| DataMissing | 38 Network out of order |
| UnexpectedDataValue | 38 Network out of order |
| TeleserviceNotProvisioned | 50 Requested facility not subscribed |
| CallBarred | |
| - barringServiceActive | 10 Call barred |
| - operatorBarring | 8 Operator determined barring |

NOTE: The coding and the use of the RP-ERROR message is specified in 3GPP TS 24.011 [13]. The operation SendInfoForMO-SMS is not used by the SGSN.

If errors are indicated by the SMS-IWMSC (negative outcome of the "forwardShortMessage),) the MSC or the SGSN shall send a failure report (i.e. a RP-ERROR message) to the MS, with the error cause coded as follows:

| Return error from ForwardShortMessage | Cause value in the RP-ERROR message |
|--|---------------------------------------|
| DataMissing | 38 Network out of order |
| FacilityNotSupported | 69 Requested facility not implemented |
| UnexpectedDataValue | 38 Network out of order |
| SM-DeliveryFailure cause: unknownSC | 1 Unassigned number |
| SM-DeliveryFailure cause: SC-Congestion | 42 Congestion |
| SM-DeliveryFailure cause: invalidSME-Addr ¹⁾ | 21 Short message transfer rejected |
| SM-DeliveryFailure cause: subscriberNotSC-Subscriber | 28 Unidentified subscriber |
| Local or lower layer failure (e.g. reject condition, timer expired or transaction abort) | 38 Network out of order |

¹⁾ [This cause includes the case when the outcome of optional HLR interrogation is unacceptable \(see clause 8.2.2\)](#)

NOTE: The coding and the use of the RP-ERROR message is specified in 3GPP TS 24.011 [13].

****** End of Modifications ******