

Source: T1
Title: TS 34.122 "Terminal Conformance Specification; Radio Transmission and Reception (TDD)" v2.0.0
Agenda item: 6.1
Document for: Approval

Presentation of Specification to TSG or WG

Presentation to: TSG T Meeting # 8
Document for presentation: TS 34.122 Version 2.0.0
Source: TSG T WG1
Presented for: Approval

Abstract of document:

Terminal Conformance Specifications; Radio transmission and reception (TDD)

Containing test specifications about

- Transmitter Characteristics
- Receiver Characteristics
- Performance Requirements
- Requirements for support of RRM

Core specification for this document are:

- TS25.102 (UTRA (UE) TDD; Radio Transmission and Reception)
- TS 25.123 (Requirements for Support of Radio Resource Management (TDD))

Serving specifications for this document are:

- TS34.109 (Terminal logical test interface (FDD/TDD))
- TS 34.108 (Common Test Environment)

Peer specifications with respect to this document are:

- TS 34.121 (Terminal Conformance Specifications; Radio Transmission and Reception (FDD))
- TS 25.142 (Base Station Conformance Testing (TDD))
- TS 25.141 (Base Station Conformance Testing (FDD))

Changes since last presentation to **TSG T Meeting # 7:**

Summary of the major changes towards version 1.3.0:

Inputs from T1RF #11 (Munich)

- User Equipment maximum output power
- Uplink Power control / initial accuracy
- Uplink Power control / differential accuracy, controlled input
- Transmit on/off time mask

Agreed CRs to TS 102

- CR 15 Description of signal levels for Receiver Characteristics
- CR 17 Spurious emissions
- CR 18 Performance requirements for BS transmit diversity
- CR 19 Correction for UE TDD Blocking requirements
- CR 20 Correction to UL Power control “differential accuracy”, measured input
- CR 21 Clarification of ACLR
- CR 22 Clock Accuracy
- CR 23 Peak Code Domain Error
- CR 24 Modulation Accuracy
- CR 25 Out of Synch handling of UE in TS 25.102

Summary of the major changes towards v1.4.0:

Inputs from T1RF #12 (Yokohama)

5.4.3 Transmit off power

Changes according to RAN4 #12 (Turku)

- Correction of DL measurement channels for TDD
- Reference Measurement Channel for UE PCDE in TDD mode
- Correction for 25.102 concerning uplink power control
- Performance requirements with TFCI decoding for TDD UE
- UE P-CCPCH BLock STTD performance requirements
- Clarification on PCDE

Summary of the major changes towards v1.5.0:

Current state:

Item	Estimated Level of Completeness	State of the corespecs 25.102
5. Transmitter Characteristics	85%	90%
6. Receiver Characteristics	90%	90%
7. Performance Requirements	90%	90%
Annexes	80%	90%
Requirements for Support of Radio Resource Management (TDD)	0%	State of corespec 25.123 50%

Outstanding Issues:

Coverage of 25.123 core specifications

Confidence level for statistical measurements

Requirements for test equipment, measurement uncertainties

Additional conditions (frequency range, battery, environmental conditions)

Contentious Issues:

Little support from the serving specifications (34.108 and 34.109) for 34.122

3G TS 34.122 V2.0.0 (2000-06)

Technical Specification

The present document has been developed within the 3rd Generation Partnership Project (3GPP™) and may be further elaborated for the purposes of 3GPP.

**3rd Generation Partnership Project;
Technical Specification Group Terminal;
Terminal Conformance Specification;
Radio transmission and reception (TDD)
(Release 1999)**

The present document has not been subject to any approval process by the 3GPP Organisational Partners and shall not be implemented.



This Specification is provided for future development work within 3GPP only. The Organisational Partners accept no liability for any use of this Specification. Specifications and reports for implementation of the 3GPP™ system should be obtained via the 3GPP Organisational Partners' Publications Offices.



Keywords

Testing, UMTS

3GPP

Postal address

3GPP support office address

650 Route des Lucioles - Sophia Antipolis
Valbonne - FRANCE
Tel.: +33 4 92 94 42 00 Fax: +33 4 93 65 47 16

Internet

<http://www.3gpp.org>

Copyright Notification

No part may be reproduced except as authorized by written permission.
The copyright and the foregoing restriction extend to reproduction in all media.

© 2000, 3GPP Organizational Partners (ARIB, CWTS, ETSI, T1, TTA, TTC).
All rights reserved.

Contents

Foreword	10
1 Scope.....	11
2 References.....	11
3 Definitions, abbreviations and equations	11
3.1 Definitions	11
3.2 Abbreviations.....	11
3.3 Equations	12
4 Frequency bands and channel arrangement	12
4.1 General.....	12
4.2 Frequency bands	12
4.3 TX–RX frequency separation	12
4.4 Channel arrangement	13
4.4.1 Channel spacing	13
4.4.2 Channel raster.....	13
4.4.3 Channel number	13
5 Transmitter Characteristics	13
5.1 General.....	13
5.2 User Equipment maximum output power	13
5.2.1 Definition and applicability.....	13
5.2.2 Conformance requirements	14
5.2.3 Test purpose	14
5.2.4 Method of test	14
5.2.4.1 Initial conditions.....	14
5.2.4.2 Procedure.....	15
5.2.5 Test Requirements.....	15
5.3 Frequency Stability	15
5.3.1 Definition and applicability.....	15
5.3.2 Conformance requirements	15
5.3.3 Test purpose	15
5.3.4 Method of test	16
5.3.4.1 Initial conditions	16
5.3.4.2 Procedure.....	16
5.3.5 Test Requirements.....	16
5.4 Output Power Dynamics	16
5.4.1 Uplink power control	16
5.4.1.1 Initial accuracy	16
5.4.1.1.1 Definition and applicability	16
5.4.1.1.2 Conformance requirements	17
5.4.1.1.3 Test purpose.....	17
5.4.1.1.4 Method of test	17
5.4.1.1.4.1 Initial conditions.....	17
5.4.1.1.4.2 Procedure.....	17
5.4.1.1.5 Test requirements.....	17
5.4.1.2 Differential accuracy, controlled input	18
5.4.1.2.1 Definition and applicability	18
5.4.1.2.2 Conformance requirements	18
5.4.1.2.3 Test purpose.....	18
5.4.1.2.3 Method of test	18
5.4.1.2.3.1 Initial conditions.....	18
5.4.1.2.3.2 Procedure.....	19
5.4.1.2.4 Test requirements.....	19
5.4.2 Minimum transmit power.....	19
5.4.2.1 Definition and applicability.....	19
5.4.2.2 Conformance requirements.....	19

5.4.2.3	Test purpose	19
5.4.2.4	Method of test.....	20
5.4.2.4.1	Initial conditions	20
5.4.2.4.2	Procedure	20
5.4.2.5	Test requirements	20
5.4.3	Transmit OFF power	20
5.4.3.1	Definition and applicability	20
5.4.3.2	Conformance requirements.....	20
5.4.3.3.	Test purpose	20
5.4.3.4.	Method of test.....	20
5.4.3.5.	Test requirements	20
5.4.4.	Transmit ON/OFF Time mask	21
5.4.4.1.	Definition and applicability	21
5.4.4.2.	Conformance Requirements	21
5.4.4.3.	Test Purpose	21
5.4.4.4.	Method of test.....	21
5.4.4.4.1.	Initial conditions	21
5.4.4.4.2.	Procedure	22
5.4.4.5.	Test requirements	22
5.4.5	Out-of-synchronisation handling of output power	22
5.4.5.1	Requirement	22
5.5	Output RF spectrum emissions	23
5.5.1	Occupied bandwidth.....	23
5.5.1.1	Definition and applicability	23
5.5.1.2	Conformance requirements.....	23
5.5.1.3	Test purpose	23
5.5.1.4	Method of test.....	24
5.5.1.4.1	Initial conditions	24
5.5.1.4.2	Procedure	24
5.5.1.5	Test requirements	24
5.5.2	Out of band emission.....	24
5.5.2.1	Spectrum emission mask	24
5.5.2.1.1	Definition and applicability	24
5.5.2.1.2	Conformance requirements	24
5.5.2.1.3	Test purpose.....	25
5.5.2.1.4	Method of test	25
5.5.2.1.5	Test requirements.....	25
5.5.2.2	Adjacent Channel Leakage power Ratio (ACLR)	25
5.5.2.2.1	Definition and applicability	25
5.5.2.2.2	Conformance requirements	25
5.5.2.2.3	Test purpose.....	26
5.5.2.2.4	Method of test	26
5.5.2.2.5	Test requirements.....	26
5.5.3	Spurious emissions.....	26
5.5.3.1	Definition and applicability	26
5.5.3.2	Conformance requirements.....	27
5.5.3.3	Test purpose	27
5.5.3.4	Method of test.....	27
5.5.3.4.1	Initial conditions	27
5.5.3.4.2	Procedure	27
5.5.3.5	Test requirements	27
5.6	Transmit Intermodulation	28
5.6.1	Definition and applicability.....	28
5.6.2	Conformance requirements	28
5.6.3	Test purpose	28
5.6.4	Method of test	28
5.6.4.1	Initial conditions.....	28
5.6.4.2	Procedure.....	28
5.6.5	Test requirements	29
5.7	Transmit Modulation	29
5.7.1	Error Vector Magnitude	29
5.7.1.1	Definition and applicability	29

5.7.1.2	Conformance requirements.....	29
5.7.1.3	Test purpose	29
5.7.1.4	Method of test.....	29
5.7.1.4.1	Initial conditions	29
5.7.1.4.2	Procedure	29
5.7.1.5	Test requirements	29
5.7.2	Peak code domain error.....	30
5.7.2.1	Definition and applicability.....	30
5.7.2.2	Conformance Requirement.....	30
5.7.2.3	Test purpose	30
5.7.2.4	Method of test.....	30
5.7.2.4.1	Initial conditions	30
5.7.2.4.2	Procedure	30
5.7.2.5	Test requirements	30
6	Receiver Characteristics	31
6.1	General.....	31
6.2	Reference sensitivity level.....	31
6.2.1	Definition and applicability.....	31
6.2.2	Conformance requirements	31
6.2.3	Test purpose	31
6.2.4	Method of test	32
6.2.4.1	Initial conditions.....	32
6.2.4.2	Procedure.....	32
6.2.5	Test requirements	32
6.3	Maximum Input Level.....	32
6.3.1	Definition and applicability.....	32
6.3.2	Conformance requirements	32
6.3.3	Test purpose	32
6.3.4	Method of test	32
6.3.4.1	Initial conditions.....	32
6.3.4.2	Procedure.....	33
6.3.5	Test requirements	33
6.4	Adjacent Channel Selectivity (ACS).....	33
6.4.1	Definition and applicability.....	33
6.4.2	Conformance requirements	33
6.4.3	Test purpose	33
6.4.4	Method of test	34
6.4.4.1	Initial conditions.....	34
6.4.4.2	Procedure.....	34
6.4.5	Requirements.....	34
6.5	Blocking Characteristics	34
6.5.1	Definition and applicability.....	34
6.5.2	Conformance requirements	34
6.5.3	Test purpose	35
6.5.4	Method of test	35
6.5.4.1	Initial conditions.....	35
6.5.4.2	Procedure.....	35
6.5.5	Test requirements	36
6.6	Spurious Response.....	36
6.6.1	Definition and applicability.....	36
6.6.2	Conformance requirements	36
6.6.3	Test purpose	36
6.6.4	Method of test	37
6.6.4.1	Initial conditions.....	37
6.6.4.2	Procedure.....	37
6.6.5	Test requirements	37
6.7	Intermodulation Characteristics.....	37
6.7.1	Definition and applicability.....	37
6.7.2	Conformance requirements	37
6.7.3	Test purpose	37
6.7.4	Method of test	38

6.7.4.1	Initial conditions	38
6.7.4.2	Procedure	38
6.7.5	Test requirements	38
6.8	Spurious Emissions	38
6.8.1	Definition and applicability	38
6.8.2	Conformance requirements	38
6.8.3	Test purpose	38
6.8.4	Method of test	39
6.8.4.1	Initial conditions	39
6.8.4.2	Procedure	39
6.8.5	Test requirements	39
7	Performance Requirements	39
7.1	General	39
7.2	Demodulation in static propagation conditions	39
7.2.1	Demodulation of DCH	39
7.2.1.1	Definition and applicability	39
7.2.1.2	Conformance requirements	39
7.2.1.3	Test purpose	40
7.2.1.4	Method of test	40
7.2.1.4.1	Initial conditions	40
7.2.1.4.2	Procedure	40
7.2.1.5	Test requirements	40
7.3	Demodulation of DCH in multipath fading conditions	41
7.3.1	Multipath fading Case 1	41
7.3.1.1	Definition and applicability	41
7.3.1.2	Conformance requirements	41
7.3.1.3	Test purpose	41
7.3.1.4	Method of test	41
7.3.1.4.1	Initial conditions	41
7.3.1.4.2	Procedure	42
7.3.1.5	Test requirements	42
7.3.2	Multipath fading Case 2	42
7.3.2.1	Definition and applicability	42
7.3.2.2	Conformance requirement	42
7.3.2.3	Test purpose	42
7.3.2.4	Method of test	43
7.3.2.4.1	Initial conditions	43
7.3.2.4.2	Procedure	43
7.3.2.5	Test requirements	43
7.3.3	Multipath fading Case 3	43
7.3.3.1	Definition and applicability	43
7.3.3.2	Conformance requirements	43
7.3.3.3	Test purpose	44
7.3.3.4	Method of test	44
7.3.3.4.1	Initial conditions	44
7.3.3.4.2	Procedure	44
7.3.3.5	Test requirements	44
7.4	Base station transmit diversity mode	44
7.4.1	Demodulation of BCH in Block STTD mode	44
7.4.1.1	Conformance requirements	44
8	Requirements for Support of RRM	46
8.1	General	46
8.2	Idle Mode Tasks	46
8.2.1	Introduction	46
8.2.2	RF Cell Selection Scenario	46
8.2.2.1	Requirements for Cell Selection single carrier single cell case	46
8.2.2.2	Requirements for Cell Selection multicarrier carrier multi cell case	46
8.2.3	RF Cell Re-Selection Scenario	46
8.2.3.1	Requirements for Cell Re-Selection single carrier multi cell case	46
8.2.4	PLMN Selection and Re-Selection Scenario	46

8.2.5	Location Registration Scenario	46
8.3	RRC Connection mobility.....	46
8.3.1	Handover.....	46
8.3.1.1	Introduction	46
8.3.1.2	Handover 3G to 3G	46
8.3.1.2.1	TDD/TDD Handover	46
8.3.1.2.2	TDD/FDD Handover	46
8.3.1.3	Handover 3G to 2G	46
8.3.1.3.1	Handover to GSM	46
8.3.2	Radio Link Management.....	46
8.3.2.1	Link adaptation.....	46
8.3.3	Cell Update	46
8.3.4	URA Update.....	46
8.4	RRC Connection Control.....	47
8.4.1	Radio Access Bearer Control	47
8.5	Dynamic Channel Allocation.....	47
8.6	Timing characteristics.....	47
8.6.1	Timing Advance (TA) Requirements.....	47
8.7	Measurements Performance Requirements.....	47
8.7.1	Measurements Performance for UE	47
	Annex A (informative): Connection Diagrams	48
	Annex B (normative) Global In-Channel TX-Test	54
B.1	General.....	54
B.2	Definition of the process.....	54
B.2.1	Basic principle.....	54
B.2.2	Output signal of the TX under test	54
B.2.3	Reference signal	54
B.2.4	void	54
B.2.5	Classification of measurement results	54
B.2.6	Process definition to achieve results of type "deviation"	55
B.2.7	Process definition to achieve results of type "residual"	55
B.2.7.1	Error Vector Magnitude (EVM).....	56
B.2.7.2	Peak Code Domain Error (PCDE)	56
B.3	Notes.....	57
	Annex C (normative): Measurement channels.....	59
C.1	General.....	59
C.2	UL Reference measurement channels.....	59
C.2.1	UL reference measurement channel (12.2 kbps).....	59
C.2.2	UL multi code reference measurement channel (12.2 kbps).....	60
C.2.3	UL reference measurement channel (64 kbps).....	61
C.2.4	UL reference measurement channel (144 kbps).....	62
C.2.5	UL reference measurement channel (384 kbps).....	63
C.3	DL Reference measurement channels.....	64
C.3.3	DL reference measurement channel (12.2 kbps).....	64
C.3.2	DL reference measurement channel (64 kbps).....	65
C.3.3	DL reference measurement channel (144 kbps).....	66
C.3.4	DL reference measurement channel (384 kbps).....	67
C.3.5	BCH reference measurement channel	68
	Annex D (normative): Propagation conditions	69
D.1	Test Environments.....	69
D.2	Propagation Conditions.....	69
D.2.1	Static propagation condition.....	69
D.2.2	Multi-path fading propagation conditions	69
	Annex E (normative): Common RF test conditions.....	70
E.1	General.....	70
E.2	Connection Set-up	70
E.3	During connection	70
E.3.1	Measurement of Tx Characteristics.....	70
E.3.2	Measurement of Rx Characteristics	71

E.3.3 Measurement of Performance requirements..... 71

Annex F (normative): Requirements of Test Equipment 72

F.1 General..... 72

F.2 Acceptable uncertainty of measurement equipment 72

F.3 Interpretation of measurement results..... 72

Annex G (normative): Environmental conditions..... 73

G.1 General..... 73

G.2 Environmental requirements..... 73

G.2.1 Temperature 73

G.2.2 Voltage 73

G.2.3 Vibration 73

Annex H (normative): Terminal Baseline and Service Implementation Capabilities (TDD) 75

H.1 Baseline Implementation Capabilities: 75

H.2 Service Implementation Capabilities: 75

Foreword

This Technical Specification (TS) has been produced by the 3rd Generation Partnership Project (3GPP).

The contents of the present document are subject to continuing work within the TSG and may change following formal TSG approval. Should the TSG modify the contents of the present document, it will be re-released by the TSG with an identifying change of release date and an increase in version number as follows:

Version x.y.z

where:

- x the first digit:
 - 1 presented to TSG for information;
 - 2 presented to TSG for approval;
 - 3 or greater indicates TSG approved document under change control.
- y the second digit is incremented for all changes of substance, i.e. technical enhancements, corrections, updates, etc.
- z the third digit is incremented when editorial only changes have been incorporated in the document.

1 Scope

This present document specifies the measurement procedure for the conformance test of the mobile station that contain transmitting characteristics, receiving characteristics and performance requirements and requirements for support of RRM (Radio Resource Management) in TDD mode.

2 References

The following documents contain provisions which, through reference in this text, constitute provisions of the present document.

- References are either specific (identified by date of publication, edition number, version number, etc.) or non-specific.
- For a specific reference, subsequent revisions do not apply.
- For a non-specific reference, subsequent revisions do apply.

[1] 3GPP TS 25.102: "UE Radio transmission and reception (TDD)".

Note: The current version reflects 3GPP TS 25.102 version 3.2.0

In addition CRs agreed on RAN4 level (Meeting #13, Turku, Finland, May 2000) are taken into account

[2] 3GPP TS 25.123: "Requirements for Support of Radio Resource Management (TDD)".

[3] 3GPP TS 34.108 "Common Test Environments for User Equipment (UE) Conformance Testing"

[4] 3GPP TS 34.109: "Logical Test Interface; Special conformance testing functions".

[5] 3GPP TS 25.224 Physical Layer Procedures (TDD)

[6] 3GPP TR 21.905: "Vocabulary for 3GPP Specifications".

[7] 3GPP TR 25.990: "Vocabulary".

[8] ITU-R Recommendation SM.328-9: "Spectra and bandwidth of emissions".

3 Definitions, abbreviations and equations

Definitions, symbols, abbreviations and equations used in the present document are listed in TR 21.905 [6] and TR 25.990 [7].

3.1 Definitions

For the purpose of the present document, the following additional definitions apply:

Average power: [TBD]

3.2 Abbreviations

For the purpose of the present document, the following additional abbreviations apply.

AFC	Automatic Frequency Control
ATT	Attenuator
EVM	Error Vector Magnitude
FFS	For Further Study

HYB	Hybrid
OBW	Occupied Bandwidth
OCNS	Orthogonal Channel Noise Simulator, a mechanism used to simulate the users or control signals on the other orthogonal channels of a downlink.
PCDE	Peak Code Domain Error
PRBS	Pseudo Random Bit Sequence
SS	System Simulator
TBD	To Be Defined
TS	Time Slot
RRC	Root-Raised Cosine

3.3 Equations

For the purpose of the present document, the following additional equations apply.

I_{BTS}	Interference signal power level at BTS in dBm, which is broadcasted on BCH
I_{oac}	The power spectral density of the adjacent frequency channel as measured at the UE antenna connector.
$\frac{\sum DPCH_Ec}{I_{or}}$	The ratio of the sum of DPCH_Ec for one service in case of multicode to the total transmit power spectral density of the downlink at the BS antenna connector

4 Frequency bands and channel arrangement

4.1 General

The information presented in this section is based on a chip rate of 3.84 Mcps.

NOTE: Other chip rates may be considered in future releases.

4.2 Frequency bands

UTRA/TDD is designed to operate in the following bands;

- a) 1900 – 1920 MHz: Uplink and downlink transmission
2010 – 2025 MHz: Uplink and downlink transmission
- b)* 1850 – 1910 MHz: Uplink and downlink transmission
1930 – 1990 MHz: Uplink and downlink transmission
- c)* 1910 – 1930 MHz: Uplink and downlink transmission

* Used in ITU Region 2.

Additional allocations in ITU region 2 are for further study.

Deployment in existing or other frequency bands is not precluded.

The co-existence of TDD and FDD in the same bands is still under study in RAN WG4.

4.3 TX–RX frequency separation

No TX-RX frequency separation is required as Time Division Duplex (TDD) is employed. Each TDMA frame consists of 15 timeslots where each timeslot can be allocated to either transmit or receive.

4.4 Channel arrangement

4.4.1 Channel spacing

The nominal channel spacing is 5 MHz, but this can be adjusted to optimise performance in a particular deployment scenario.

4.4.2 Channel raster

The channel raster is 200 kHz, which means that the carrier frequency must be a multiple of 200 kHz.

4.4.3 Channel number

The carrier frequency is designated by the UTRA absolute radio frequency channel number (UARFCN). The value of the UARFCN in the IMT2000 band is defined as follows:

$$N_f = 5 * (F - \text{MHz}) \quad 0.0 \text{ MHz} \leq F \leq 3276.6 \text{ MHz} \quad \text{where } F \text{ is the carrier frequency in MHz}$$

5 Transmitter Characteristics

5.1 General

Transmitting performance test of the UE is implemented during communicating with the SS via air interface. The procedure is uses normal call protocol until the UE is communicating on traffic channel basically. (Refer to TS 34.108 [3] Common Test Environments for User Equipment (UE) Conformance Testing) On the traffic channel, the UE provides special function for testing that is called Logical Test Interface and the UE is tested using this function. (Refer to TS 34.109 [4] Logical Test Interface; Special conformance testing functions).

Unless detailed the transmitter characteristic are specified at the antenna connector of the UE. For UE with integral antenna only, a reference antenna with a gain of 0 dBi is assumed. Transmitter characteristics for UE(s) with multiple antennas/antenna connectors are for further study.

The UE antenna performance has a significant impact on system performance, and minimum requirements on the antenna efficiency are therefore intended to be included in future versions of this specification. It is recognized that different requirements and test methods are likely to be required for the different types of UE.

The common RF test conditions are defined in annex E, and each test conditions in this Chapter should refer annex E. Individual test conditions are defined in the paragraph of each test.

5.2 User Equipment maximum output power

5.2.1 Definition and applicability

The maximum output power and its tolerance are defined according to the Power Class of the UE.

The **output power**, P_{out} , of the UE is the power when averaged (in the sense of thermal power) over the useful part of the TS at the maximum power control setting delivered in to a load with resistance equal to the nominal load impedance.

The requirements in this test apply to all UTRA – TDD- UEs

Notes copied from TS 25.102 clause 6.2.1 :

1. The maximum output power refers to.....

2. For multi-code operation the maximum output power will be reduced by the difference of peak to average ratio between single and multi-code transmission.
3. The tolerance of the maximum power is below the prescribed value even at the multi-code transmission mode
4. For UE using directive antennas for transmission, a class dependent limit will be placed on the maximum EIRP (Equivalent Isotropic Radiated Power).

5.2.2 Conformance requirements

The error of the UE maximum output power shall not exceed the tolerance shown in Tables 5.2.2 a and b for single and multi-code.

Table 5.2.2.a: Maximum Output Power single code

Power Class	Maximum output power	Tolerance
1		
2	+24 dBm	+1dB /-3dB
3	+21 dBm	+2dB /-2dB
4		

Table 5.2.2.b: Maximum Output Power multi code

Power Class	Maximum output power	Tolerance
1		
2	[] dBm	+1dB /-3dB
3	[] dBm	+2dB /-2dB
4		

The reference for this requirement is 25.102 clause 6.2.

5.2.3 Test purpose

For the following reasons:

Limit interference.

Verify that the maximum output power is achievable.

It is the purpose of the test to verify that the UE's maximum output power is within its tolerance limits under all environmental conditions.

5.2.4 Method of test

5.2.4.1 Initial conditions

- (1) Connect the SS to the UE antenna connector as shown in Figure A.1.
- (2) Calls are set up according to the Generic call setup procedure using parameters as specified in Tables 5.2.4.a and b
- (3) Enter the UE into loopback test mode and start the loopback test.

Table 5.2.4.a: Test parameters for Maximum Output Power single code

Parameter	Value/description
UL Reference measurement channel	12.2kbps, according to annex C.2.1
Uplink Power Control	SS level and signalling values such that UE transmits maximum power.
Data content	real life (sufficient irregular)

Table 5.2.4.b: Test parameters for Maximum Output Power multicode

Parameter	Value/description
Reference measurement channel	Multicode 12.2kbps, according to annex C.2.2
Uplink Power Control	SS level and signalling values such that UE transmits maximum power
Data content	real life (sufficient irregular)

5.2.4.2. Procedure

- (1) Measure thermal power over the useful part of the burst.
with a measurement bandwidth of at least 5 MHz.
- (2) Average over TBD time slots.
- (3) Run step (1) and (2) for RF channels Low / Mid / High

5.2.5. Test Requirements

The output power, measured in step (2) of subclause 5.2.4.2, shall not exceed the prescribed tolerance in Table 5.2.2 a and b.

5.3 Frequency Stability

5.3.1 Definition and applicability

The frequency stability is the difference of the modulated carrier frequency between the RF transmission from the UE and the RF transmission from the BS. The UE shall use the same frequency source for both RF frequency generation and chip clocking.

The requirements of this test apply to all types of UTRA- UE.

5.3.2 Conformance requirements

The UE frequency stability shall be within ± 0.1 ppm compared to signals received from the BS.

The reference for this requirement is TS 25.102 subclause 6.3.

5.3.3 Test purpose

Reliable frequency stability of the UE's transmitter in certain tolerance limits is prerequisite for connectivity.

This test stresses the ability of the UE's receiver to derive correct frequency information from the received signal for the transmitter.

5.3.4 Method of test

5.3.4.1 Initial conditions

- (1) Connect the SS to the UE antenna connector as shown in Figure A.1.
- (2) A call is set up according to the Generic call setup procedure using parameters as specified in table 5.3.4.1.
- (3) Enter the UE into loopback test mode and start the loopback test.

Table 5.3.4.1: Test parameters for Frequency Stability

Parameter	Value/description
SS level	-105 dBm (reference sensitivity)
UL reference measurement channel	12.2kbps according to annex C.2.1.
Data content	real life (sufficient irregular)

5.3.4.2 Procedure

- (1) Measure the frequency error Δf across the TS according to annex B.
- (2) Repeat step (1) for 200 bursts (time slots).
- (3) Run Step (1) and (2) for RF channels Low /Mid/ High.

5.3.5 Test Requirements

For all measured bursts (time slots) , the frequency error, derived in subclause 5.3.4.2, shall not exceed $10E-7$.

5.4 Output Power Dynamics

Power control is used to limit the interference level.

5.4.1 Uplink power control

Uplink power control is the ability of the UE transmitter to sets its output power in accordance with measured downlink path loss, values determined by higher layer signalling and parameter α as defined in TS 25.224 [5]. The output power is defined as the average power of the transmit timeslot, and is measured with a filter that has a Root-Raised Cosine (RRC) filter response with a roll off $\alpha = 0.22$ and a bandwidth equal to the chip rate.

5.4.1.1. Initial accuracy

5.4.1.1.1. Definition and applicability

Initial Uplink power control is the ability of the UE transmitter to sets its output power in accordance with measured downlink path loss, and signalling values: I_{BTS} and Constant value, received from the BCH and applicable for the PRACH

The requirements and this test apply to all types of UTRA - UEs.

5.4.1.1.2. Conformance requirements

The UE power control, initial accuracy, is given in Table 5.4.1.1.2.

Table 5.4.1.1.2. Initial uplink power control tolerance

Normal conditions	± 9 dB
Extreme conditions	± 12 dB

The reference for this requirement is [1] TS 25.102 clause 6.4.1.1.

5.4.1.1.3. Test purpose

The power of the received signal at the UE and the BCCH information control the power of the transmitted UE signal with the target to transmit at lowest power, acceptable for proper communication.

The test stresses the ability of the receiver to measure the received power over the receiver dynamic range and to derive from this correct transmitter-power

5.4.1.1.4. Method of test

5.4.1.1.4.1. Initial conditions

Connect the SS to the MS antenna connector as shown in Figure A.1.

A call is set up according to the generic call setup procedure [3] using parameters as specified in Table 5.4.1.1.4. The RACH procedure within the call setup is used for the test.

Table 5.4.1.1.4. Test parameters for uplink Power Control

	Upper dynamic range	middle	Sensitivity level
SS transmit power	[-25 dBm]	[-65 dBm]	[-105 dBm]
Broadcasted transmit-power	[35 dBm]	[35 dBm]	[24 dBm]
Simulated path loss = Broadcasted TX – SS TX Power	[60 dB]	[100 dB]	[129 dB]
I_{BTS}	[-75]	[-100]	[-110]
Constant value	[-10 dB]	[-10 dB]	[-10 dB]
Nominal expected UE TX power	[-25dBm]	[-10dBm]	[+9dBm] ²⁾

Note 1: While the SS transmit power shall cover the UE receiver input dynamic range, the logical parameters: broadcasted transmit power, I_{BTS} , and constant value are chosen to achieve a UE TX power, located within the TX output power dynamic range of a class 3 UE.

Note 2: Nominal TX output power 9 dBm allows to check the uplink power control algorithm within the entire tolerance range (9 dBm \pm 12 dB: 9 dBm +12 dB =21 dBm = max power class 3).

5.4.1.1.4.2. Procedure

- (1) Set the SS transmit power according to table 5.4.1.1.4.
- (2) Measure the RACH output power of the UE according to Annex B.
- (3) Repeat the test for all SS transmit powers and parameters in table 5.4.1.1.4.

5.4.1.1.5. Test requirements

The deviation with respect to the nominal expected UE TX power (table 5.4.1.1.2.), derived in step 2, shall not exceed the prescribed tolerance in Table 5.4.1.1.2.

5.4.1.2. Differential accuracy, controlled input

5.4.1.2.1 Definition and applicability

Uplink power control, differential accuracy, is the ability of the UE transmitter to sets its output power in accordance with measured downlink path loss, and the signalling values: I_{BTS} , SIR_{Target} , Constant Value, received from higher layers and applicable for the DPCH.

Specifically, the uplink power control, differential accuracy, controlled input, is defined as the error in the UE transmitter power step as a result of a step in SIR_{TARGET} when the parameter $\alpha=0$, α calculated in the UE.

The requirements of this test apply to all types of UTRA -UE.

5.4.1.2.2. Conformance requirements

The step in SIR_{TARGET} shall be rounded to the closest integer dB value. The error shall not exceed the values in table 5.4.1.2.2.

Table 5.4.1.2.2.: Transmitter power step tolerance as a result of control power step

ΔSIR_{TARGET} [dB]	Transmitter power step tolerance [dB]
$\Delta SIR_{TARGET} \leq 1$	± 0.5
$1 < \Delta SIR_{TARGET} \leq 2$	± 1
$2 < \Delta SIR_{TARGET} \leq 3$	± 1.5
$3 < \Delta SIR_{TARGET} \leq 10$	± 2
$10 < \Delta SIR_{TARGET} \leq 20$	± 4
$20 < \Delta SIR_{TARGET} \leq 30$	± 6
$30 < \Delta SIR_{TARGET}$	$\pm 9^{(1)}$

(1) Value is given for normal conditions. For extreme conditions value is ± 12

The reference for this requirement is [1] TS 25.102 clause 6.4.1.2.

5.4.1.2.3. Test purpose

It is verified if the UE sets correct uplink power steps in response to steps in the signalling value SIR_{Target} , signalled via the downlink to the UE

under the following conditions: keeping the other signalling parameters constant and deactivating any influence due to varying pathloss.

5.4.1.2.3. Method of test

5.4.1.2.3.1 Initial conditions

- (1) Connect the SS to the MS antenna connector as shown in Figure A.1.
- (2) A call is set up according to the generic call setup procedure using parameters as specified in Table 5.4.1.2.4

Table 5.4.1.2.4. Test parameters for Uplink Power Control, Differential Accuracy, Controlled Input

Parameter	Value/description
UL reference measurement channel	12.2kbps according to annex C.2.1.
BS Transmit to UE Transmit delay	7 TSS--> $\alpha=0$
SSTransmit power	[-65 dBm]
Reference transmit power broadcast on BCH	[35 dBm]
I_{BTS}	[-100]
Constant value	[-10]
Data content	real life (sufficient irregular)

5.4.1.2.3.2 Procedure

Using the SIR_{Target} -value in the downlink,

cover the UE-transmitter dynamic range by commanding the UEs power with the signalling value SIR_{Target} in a step resolution (positive and negative direction) of

- 1 dB approx. 68 steps up and 68 steps down
- 2 dB approx. 34 steps up and 34 steps down
- 3 dB approx. 22 steps up and 22 steps down
- 10 dB approx. 7 steps up and 7 steps down
- 20 dB approx. 3 steps up and 3 steps down
- 30 dB approx. 2 step up and 2 step down
- maximum stepsize 1 step up and 1 step down

Measure the power according to Annex B.

5.4.1.2.4 Test requirements

For the UE output power laying between

Max Power minus tolerance and Min Power

the step response shall not exceed the prescribed tolerance in Table 5.4.1.2.2.

5.4.2 Minimum transmit power

5.4.2.1 Definition and applicability

The minimum controlled output power of the UE is when the power control setting is set to a minimum value. This is when the uplink power control indicates a minimum transmit output power is required.

The requirements of this test apply to all types of UTRA- UE.

5.4.2.2 Conformance requirements

The minimum transmit power shall be lower than or equal to -44 dBm

The reference for this requirement is TS 25.102 [1] subclause 6.4.5.1.

5.4.2.3 Test purpose

The test purpose is to verify the ability of the UE to reduce its output power to a specified value.

5.4.2.4 Method of test

5.4.2.4.1 Initial conditions

- (1) Connect the SS to the UE antenna connector as shown in Figure A.1.
- (2) A call is set up according to the Generic call setup procedure using parameters as specified in table E.3.1.2
- (3) Enter the UE into loopback test mode and start the loopback test.

5.4.2.4.2 Procedure

- (1) Configure the UE transmitter to enable power control steps of size 1 dB.
- (2) Measure power of the UE output signal over the useful part of the active time slot according to annex B.

NOTE: Annex B returns the power in the decision points (displayed as reference power and power offset). This is equivalent to thermal power at the air-interface. Insofar 5.4.2 minimum output power is consistent with 5.2 maximum output power.(3) Average over TBD time slots.

- (4) Configure the UE transmitter to enable power control steps of 2 dB and of 3 dB, respectively, and repeat steps (2) to (3).
- (5) Run step (2) to (3) for RF channels Low Mid and High.

5.4.2.5 Test requirements

For all measurements, the minimum transmit power derived in step (3), (4) and (5) of 5.4.2.4.2 shall be below the prescribed value in subclause 5.4.2.2.

5.4.3 Transmit OFF power

5.4.3.1 Definition and applicability

The transmit OFF power state is when the UE does not transmit. This parameter is defined as the maximum output transmit power within the channel bandwidth when the transmitter is OFF.

The requirements of this test apply to all types of UTRA-UE.

5.4.3.2 Conformance requirements

The transmit OFF power shall be below -65 dBm.

The reference for this requirement is TS 25.102 subclause 6.5.1.

5.4.3.3 Test purpose

refer clause 5.4.4.3.

5.4.3.4 Method of test

refer clause 5.4.4.4

5.4.3.5 Test requirements

refer clause 5.4.4.5.

5.4.4. Transmit ON/OFF Time mask

5.4.4.1. Definition and applicability

The transmit ON/OFF time mask defines the ramping time allowed for the UE between transmit OFF power and transmit ON power.

This test applies for all UTRA TTD UEs.

5.4.4.2. Conformance Requirements

The transmit power level versus time shall meet the mask specified in figure 5.4.4.2, where the transmission period refers to the burst without guard-period for a single transmission slot, and to the period from the beginning of the burst in the first transmission slot to the end of the burst without guard period in the last transmission timeslot for consecutive transmission slots.

The reference for this requirement is TS25.102 subclause 6.5.2.1.

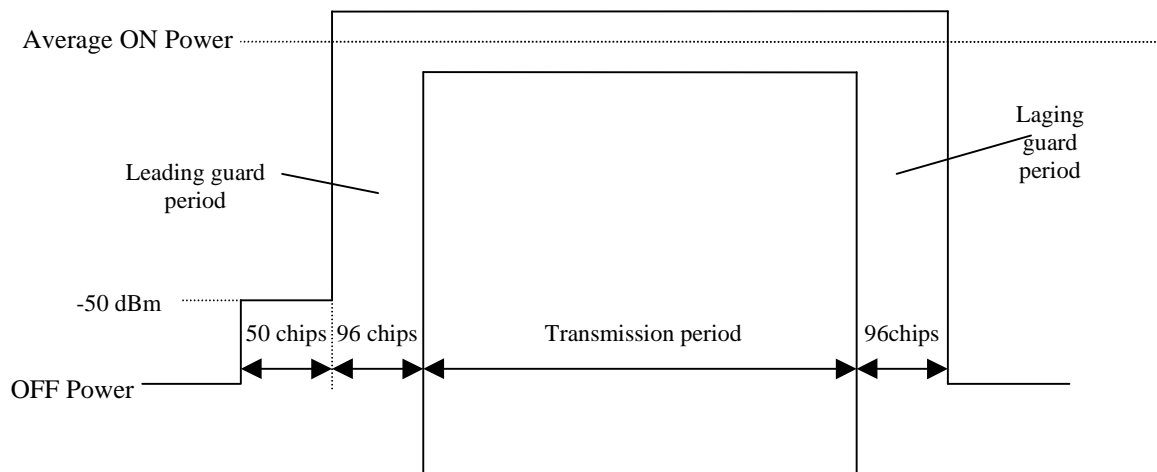

Figure 5.4.4.2: Transmit ON/OFF template

5.4.4.3. Test Purpose

It is tested if the UE TX signal uses the guard period for on-to-off and off-to-on transitions, where the time position of guard period is derived from the burst under test itself.

It is furtheron tested, if the UE TX signal is below certain limits outside transmission period and guard periods where the position in time is derived from the burst under test itself.

With this test interference to other UTRA TDD users are limited

Editor's note:

For the transmission period other tests apply.

For the absolute burst position in time other tests apply

5.4.4.4. Method of test

5.4.4.4.1. Initial conditions

Connect the SS to the UE antenna connector as shown in Figure A.1.

A call is set up according to the generic call setup procedure using parameters as specified in Table E.3.1.2.

Enter the UE into loopback test mode and start the loopback test.

5.4.4.4.2. Procedure

- (1) The time position of the midamble of the burst under test (TimeSlot s in Frame f) shall be the reference for the time position of the leading and laging guard-periods of the burst under test and, alternatively, for the equivalent guard periods of the next 2 bursts.
- (2) Record the following time periods with at least 2 samples /chip through a matched filter (RRC 0.22, BW equal to the chiprate) : TS $s-1$ and TS $s+1$ in frame f or $f+1$ or $f+2$
- (3) Calculate power samples by averaging the recorded samples of one chip duration.

5.4.4.5. Test requirements

Each power sample shall be below the limits (off Power (subclause 5.4.3.) and -50 dBm), indicated in figure 5.4.4.2.

Editor's note: In this test no power limits apply during guard period.

5.4.5 Out-of-synchronisation handling of output power

The UE shall monitor the DPCH quality in order to detect a loss of the signal on Layer 1, as specified in TS 25.224. [5] The thresholds Q_{out} and Q_{in} specify at what DPCH quality levels the UE shall shut its power off and when it may turn its transmitter on, respectively. The thresholds are not defined explicitly, but are defined by the conditions under which the UE shall shut its transmitter off and turn it on, as stated in this clause.

5.4.5.1 Requirement

The parameters in Table xx are defined using the DL reference measurement channel (12.2) kbps specified in Annex C where the CRC bits are replaced by data bits, and with static propagation conditions.

Table 5.4.5.1: DCH parameters for test of Out-of-synch handling

Parameter	Unit	Value
\hat{I}_{or}/I_{oc}	dB	-1
I_{oc}	dBm/3.84 MHz	-60
$\frac{\Sigma DPCH - E_c}{I_{or}}$	dB	See figure yy
Information Data Rate	kbps	13
TFCI	-	On

The conditions for when the UE shall shut its transmitter on and when it may turn it on are defined by the parameters in Table 5.4.5.1 together with the DPCH power level as defined in Figure 5.4.5.1.

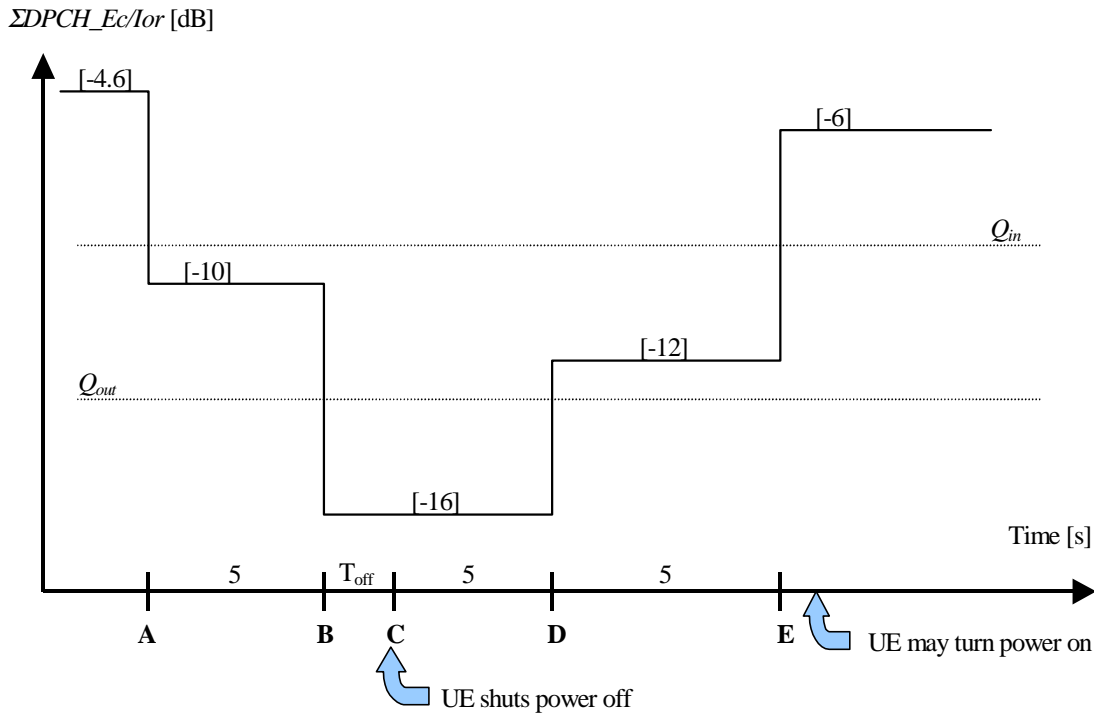

Figure 5.4.5.1. Conditions for out-of-synch handling in the UE. The indicated thresholds Q_{out} and Q_{in} are only informative.

The requirements for the UE are that:

The UE shall not shut its transmitter off before point B.

The UE shall shut its transmitter off before point C, which is $T_{off} = [200]$ ms after point B

The UE shall not turn its transmitter on between points C and E.

The UE may turn its transmitter on after point E.

5.5 Output RF spectrum emissions

5.5.1 Occupied bandwidth

5.5.1.1 Definition and applicability

Occupied bandwidth is a measure of the bandwidth containing 99% of the total integrated power for transmitted spectrum and is centered on the assigned channel frequency.

The requirements in this subclause shall apply to all types of UTRA - UE.

5.5.1.2 Conformance requirements

The occupied bandwidth shall be less than 5 MHz based on a chip rate of 3,84 Mcps.

The reference for this requirement is TS 25.102 [1] subclause 6.6.1.

5.5.1.3 Test purpose

The occupied bandwidth, defined in the Radio Regulations of the International Telecommunication Union ITU, is a useful concept for specifying the spectral properties of a given emission in the simplest possible manner; see also ITU-R Recommendation SM.328-9 [8].

The test purpose is to verify that the emission of the UE is sufficiently concentrated in the bandwidth for the service to be provided and is, therefore, not likely to create interference to other users of the spectrum beyond undue limits.

5.5.1.4 Method of test

5.5.1.4.1 Initial conditions

- (1) Connect the SS to the UE antenna connector as shown in Figure A.1.
- (2) A call is set up according to the generic call setup procedure using parameters as specified in table E.3.1.2.
- (3) Enter the UE into loopback test mode and start the loopback test.

5.5.1.4.2 Procedure

- (1) Measure the power of the transmitted signal with a measurement filter of bandwidth [30 kHz]. The characteristic of the filter shall be approximately Gaussian (typical spectrum analyzer filter). The center frequency of the filter shall be stepped in contiguous 30 kHz steps from a minimum frequency, which shall be [7,5 – 0,015] MHz below the assigned channel frequency of the transmitted signal, up to a maximum frequency, which shall be [7,5 – 0,015] MHz above the assigned channel frequency of the transmitted signal. The step duration shall be sufficient slow to capture the active TS. The measured power shall be recorded for each step.
- (2) Determine the total transmitted power by accumulating the recorded power measurements results of all steps.
- (3) Sum up the power upward from the lower boundary of the measured frequency range in '(2)' and seek the limit frequency point by which this sum becomes 0.5 % of "Total Power" and save this point as "Lower Frequency".
- (4) Sum up the power downward from the upper boundary of the measured frequency range in '(2)' and seek the limit frequency point by which this sum becomes 0.5 % of "Total Power" and save this point as "Upper Frequency".
- (5) Calculate the difference ("Upper Frequency" – "Lower Frequency" = "Occupied Bandwidth") between two limit frequencies obtained in '(4)' and '(5)'.

5.5.1.5 Test requirements

The measured Occupied Bandwidth, derived in step (5), shall not exceed 5 MHz.

5.5.2 Out of band emission

Out of band emissions are unwanted emissions immediately outside the nominal channel resulting from the modulation process and non-linearity in the transmitter but excluding spurious emissions. This out of band emission limit is specified in terms of a spectrum emission mask and adjacent channel power ratio.

5.5.2.1 Spectrum emission mask

5.5.2.1.1 Definition and applicability

The spectrum emission mask of the UE is a requirement that applies to frequencies which are between 2.5 and 12.5MHz to both sides of the carrier frequency. The out of channel emission is specified relative to the UE output power in a 3.84 MHz bandwidth.

The requirements of this test apply to all types of UTRA-UE.

5.5.2.1.2 Conformance requirements

The power of the 21dBm power class 3 UE emission shall not exceed the levels specified in table 5.5.2.1.2.

The reference for this requirement is 3G TS 25.102 clause 6.6.2.1.1

Table 5.5.2.1.2: Spectrum Emission Mask Requirement

Frequency offset from carrier • f	Minimum requirement	Measurement bandwidth
2.5 - 3.5 MHz	-35 -15*($\Delta f - 2.5$) dBc	30 kHz
3.5 - 7.5 MHz	-35- 1*($\Delta f-3.5$) dBc	1 MHz
7.5 - 8.5 MHz	-39 - 10*($\Delta f - 7.5$) dBc	1 MHz
8.5 - 12.5 MHz	-49 dBc	1 MHz

Note

1. The first and last measurement position with a 30 kHz filter is 2.515 MHz and 3.485 MHz.
2. The first and last measurement position with a 1 MHz filter is 4 MHz and 12 MHz.
3. The lower limit shall be $-50\text{dBm}/3.84\text{ MHz}$ or which ever is higher.

5.5.2.1.3 Test purpose

This test supplements Occupied Bandwidth (verifying the spectral concentration of the UE's emissions) and Adjacent Channel Leakage Ratio (simulating the perception of other UTRA receivers) in a system independent way. It is the purpose of this test to limit interferences to other systems (wideband or narrowband).

5.5.2.1.4 Method of test**5.5.2.1.4.1 Initial conditions**

- (1) Connect the SS to the UE antenna connector as shown in Figure A.1.
- (2) A call is set up according to the generic call setup procedure using parameters as specified in table E.3.1.2.
- (3) Enter the UE into loopback test mode and start the loopback test.

5.5.2.1.4.2 Procedure

- (1) Measure the power of the transmitted signal with a measurement filter of bandwidths according to table 5.5.2.1.2. The characteristic of the filter shall be approximately Gaussian (typical spectrum analyzer filter). The center frequency of the filter shall be stepped in contiguous steps according to table 5.5.2.1.2. The step duration shall be sufficient slow to capture the active TS. The measured power shall be recorded for each step.
- (2) Measure the wanted output power according to annex B.
- (3) Display the results of (1) in dBc with respect to (2).

5.5.2.1.5 Test requirements

The result 5.5.2.1.4.2. step (3) shall fulfil the requirements of table 5.5.2.1.2.

5.5.2.2 Adjacent Channel Leakage power Ratio (ACLR)**5.5.2.2.1 Definition and applicability**

Adjacent Channel Leakage power Ratio (ACLR) is the ratio of the wanted power to the power in an adjacent channel. Both the wanted power and adjacent channel power are measured with a Root-Raised Cosine (RRC) filter with roll-off $\alpha = 0.22$ and a bandwidth equal to the chip rate.

The requirements in this subclause shall apply to all types of UTRA-UE.

5.5.2.2.2 Conformance requirements

If the adjacent channel power is greater than -50dBm then the ACLR shall be better than the value specified in table 5.5.2.2.2.

The reference for this requirement is 3G TS 25.102 clause 6.6.2.2.1

Table 5.5.2.2.2: UE ACLR

Power Class	Adjacent channel	ACLR limit
2, 3	UE-channel ± 5 MHz	-33 dB
2, 3	UE-Channel ± 10 MHz	-43 dB

5.5.2.2.3 Test purpose

The test purpose is to verify the ability of the UE to limit the interference produced by the transmitted signal to other UTRA receivers operating at the first or second adjacent RF channel.

5.5.2.2.4 Method of test

5.5.2.2.4.1 Initial conditions

- (1) Connect the SS to the UE antenna connector as shown in Figure A.1.
- (2) A call is set up according to the generic call setup procedure using parameters as specified in table E.3.1.2.
- (3) Enter the UE into loopback test mode and start the loopback test.

5.5.2.2.4.2 Procedure

- (1) Measure the wanted transmitted power of the active timeslot using the method in annex B.
- (2) Average over TBD time slots.
- (3) Measure interference power at the first lower adjacent RF channel (center frequency 5 MHz below the assigned channel frequency of the transmitted signal) over the useful part of the active TS with a measurement filter that has a RRC filter response with a roll off $\alpha = 0,22$ and a bandwidth equal to the chip rate.
- (4) Average over TBD time slots.
- (5) Calculate the ACLR by
Transmitted power acc. to (2) / interference power acc. to (4).
- (6) Repeat steps (3), (4) and (5) for the second lower adjacent RF channel (center frequency 10 MHz below the assigned channel frequency of the transmitted signal) and also for the first and second upper adjacent RF channel (center frequency 5 MHz and 10 MHz, respectively).

5.5.2.2.5 Test requirements

The ACLR calculated in steps (5) and (6) of subclause 5.5.2.2.4.2 shall be equal or greater than the limits given in table 5.5.2.2.2.

5.5.3 Spurious emissions

5.5.3.1 Definition and applicability

Spurious emissions are emissions which are caused by unwanted transmitter effects such as harmonics emission, parasitic emission, intermodulation products and frequency conversion products, but exclude out of band emissions.

The frequency boundary and the detailed transitions of the limits between the requirement for out band emissions and spectrum emissions are based on ITU-R Recommendations SM.329 [8].

5.5.3.2 Conformance requirements

These requirements are only applicable for frequencies which are greater than 12.5 MHz away from the UE center carrier frequency.

The reference for this requirement is 3G TS 25.102 clause 6.6.3.1.

Table 5.5.3.2a: General Spurious emissions requirements

Frequency Bandwidth	Resolution Bandwidth	Minimum requirement
$9 \text{ kHz} \leq f < 150 \text{ kHz}$	1 kHz	-36 dBm
$150 \text{ kHz} \leq f < 30 \text{ MHz}$	10 kHz	-36 dBm
$30 \text{ MHz} \leq f < 1000 \text{ MHz}$	100 kHz	-36 dBm
$1 \text{ GHz} \leq f < 12.75 \text{ GHz}$	1 MHz	-30 dBm

Table 5.5.3.2b: Additional Spurious emissions requirements

Frequency Bandwidth	Resolution Bandwidth	Minimum requirement
$925 \text{ MHz} \leq f \leq 935 \text{ MHz}$	100 KHz	-67 dBm*
$935 \text{ MHz} < f \leq 960 \text{ MHz}$	100 KHz	-79 dBm*
$1805 \text{ MHz} \leq f \leq 1880 \text{ MHz}$	100 KHz	-71 dBm*

NOTE: The measurements are made on frequencies which are integer multiples of 200 kHz. As exceptions, up to five measurements with a level up to the applicable requirements defined in table 5.5.2.2.2. are permitted for each UARFCN used in the measurement.

5.5.3.3 Test purpose

The test purpose is to verify the ability of the UE to limit the interference caused by unwanted transmitter effects to other systems operating at frequencies which are more than 12,5 MHz away from of the UE's carrier frequency.

5.5.3.4 Method of test

5.5.3.4.1 Initial conditions

- (1) Connect the SS to the UE antenna connector as shown in Figure A.1.
- (2) A call is set up according to the generic call setup procedure using parameters as specified in table E.3.1.2.
- (3) Enter the UE into loopback test mode and start the loopback test.

5.5.3.4.2 Procedure

Measure the power of the spurious emissions applying measurement filters with bandwidths as specified in the relevant tables of 5.5.3.2. The characteristic of the filters shall be approximately Gaussian (typical spectrum analyzer filters). The center frequency of the filter shall be swept over the frequency bands as given in the tables. The sweep time shall be sufficiently low to capture the active time slots.

5.5.3.5 Test requirements

The spurious emissions measured according to subclause 5.5 .3.4.2 shall not exceed the limits specified in the relevant tables of 5.5.3.2.

5.6 Transmit Intermodulation

5.6.1 Definition and applicability

The transmit intermodulation performance is a measure of the capability of the transmitter to inhibit the generation of signals in its non linear elements caused by the presence of the wanted signal and an interfering signal reaching the transmitter via the antenna.

The UE intermodulation attenuation is defined by the ratio of the output power of the wanted signal to the output power of the intermodulation product when an interfering CW signal is added at a level below the wanted signal. Both the wanted signal power and the intermodulation product power are measured with a filter response that is root-raised cosine (RRC) with roll-off $\alpha=0.22$ and with a bandwidth equal to the chip rate.

The requirements of this test shall apply for all UTRA-UE.

5.6.2 Conformance requirements

The requirement of transmitting intermodulation for carrier spacing 5 MHz is prescribed in the table below.

The reference for this requirement is 3G TS 25.102 clause 6.7.1

Table 5.6.2: Transmit Intermodulation

Interference Signal Frequency Offset	5MHz	10MHz
Interference Signal Level	-40 dBc	
Interferer Modulation	CW	
	Note: BS Test uses a CDMA modulated signal	
Conformance Requirement	-31dBc	-41dBc

5.6.3 Test purpose

User Equipment(s) transmitting in close vicinity of each other can produce intermodulation products, which can fall into other UE, or BS receive band as an unwanted interfering signal.

It is the purpose of this test to limit interferences to the own and other systems due to intermodulation products.

5.6.4 Method of test

5.6.4.1 Initial conditions

- (1) Connect the SS and the interferer to the UE antenna connector as shown in Figure A.2.
- (2) A call is set up according to the generic call setup procedure using parameters as specified in table E.3.1.2.
- (3) Enter the UE into loopback test mode and start the loopback test.

Parameters of the interferer according to table 5.6.2.

5.6.4.2 Procedure

- (1) Measure the unwanted emissions according to 5.6.2. in a carrier offset spacing of 5 MHz and in a frequency range [5 MHz to 12.75 GHz], using an interferer +5MHz offset.

The frequency occupied by the interferer is excluded from the measurement.

- (2) Repeat (1) with the other 3 interferer-configurations (-5Mz, +10 MHz, -10 MHz).
- (3) Measure the wanted power according to annex B.

(4) Display (1) and (2) in dBc with respect to (3).

5.6.5 Test requirements

The results in (4) from subclause 5.6.4.2 shall not exceed the prescribed values in table 5.6.2.

5.7 Transmit Modulation

5.7.1 Error Vector Magnitude

5.7.1.1 Definition and applicability

The Error Vector Magnitude (EVM) is a measure of the difference between the measured waveform and the theoretical modulated waveform (the error vector). It is the square root of the ratio of the mean error vector power to the mean reference signal power expressed as a %. The measurement interval is one timeslot.

The requirement of this subclause shall apply to all types of UTRA-UE.

5.7.1.2 Conformance requirements

The Error Vector Magnitude shall not exceed 17.5 % for the parameters specified in Table 5.7.2.1.

Table 5.7.2.1.: Test parameters for Error Vector Magnitude/Peak Code Domain Error

Parameter	Unit	Level
UE Output Power	dBm	≥ -20
Operating conditions		Normal conditions
Power control step size	dB	1

The reference for this requirement is TS 25.102 [1] subclause 6.8.2.

5.7.1.3 Test purpose

The transmitter shall generate a sufficient precise waveform, to enable the receiver to achieve the specified receiver performances.

5.7.1.4 Method of test

5.7.1.4.1 Initial conditions

- (1) Connect the SS to the UE antenna connector as shown in Figure A.1.
- (2) A call is set up according to the generic call setup procedure using parameters as specified in table E.3.1.2.
- (3) Enter the UE into loopback test mode and start the loopback test.

5.7.1.4.2 Procedure

- (1) Starting from the initial conditions, measure EVM (Error Vector Magnitude) of the UE according to annex B.
- (2) Set SS-level and signalling values such that the power level of the UE is between -20 and -19 dBm
- (3) Measure EVM of the UE according to annex B.

5.7.1.5 Test requirements

The results in step (1) and (2) shall not exceed the prescribed tolerance in 5.7.1.2. for parameters specified in table 5.7.1.2.

5.7.2 Peak code domain error

5.7.2.1 Definition and applicability

The code domain error is computed by projecting the error vector power onto the code domain at a specific spreading factor. The error power for each code is defined as the ratio to the mean power of the projection onto the code, to the mean power of the composite reference waveform expressed in dB. And the Peak Code Domain Error is defined as the maximum value for Code Domain Error. The measurement interval is one timeslot.

This specification is applicable for multi-code transmission only.

The requirement of this test applies to all UTRA-UE, applicable for multi-code transmission.

5.7.2.2 Conformance Requirement

The peak code domain error shall not exceed -21 dB at spreading factor 16.

The reference for this requirement is TS 25.102 [1] subclause 6.8.3.1.

5.7.2.3 Test purpose

It is the purpose of this test to limit crosstalk among codes.

5.7.2.4 Method of test

5.7.2.4.1 Initial conditions

- (1) Connect the SS to the UE antenna connector as shown in Figure A.1.
- (2) A call is set up according to the generic call setup procedure using parameters as specified in table 5.7.2.4.1.
- (3) Enter the UE into loopback test mode and start the loopback test.

Table 5.7.2.4.1: Test parameters for Peak code Domain Error

Parameter	Value/description
Reference measurement channel	Multicode 12.2kbps, according to annex C.2.2
Uplink Power Control	SS level and signalling values such that UE transmits maximum power
Data content	real life (sufficient irregular)

5.7.2.4.2 Procedure

- (1) Starting from the initial conditions, measure peak code error(PCDE)of the UE according to annex B.
- (2) Set SS-level and signalling values such that the power level of the UE is between -20 and -19 dBm
- (3) Measure PCDE of the UE according to annex B.

5.7.2.5 Test requirements

The results in step (1) and (2) shall not exceed the prescribed tolerance in 5.7.2.2. for parameters specified in table 5.7.1.2.

6 Receiver Characteristics

6.1 General

Receiving performance test of the UE is implemented during communicating with the SS via air interface. The procedure uses normal call protocol until the UE is communicating on traffic channel basically. . (Refer to TS 34.108 [3] Common Test Environments for User Equipment (UE) Conformance Testing) On the traffic channel, the UE provides special function for testing that is described in Logical Test Interface and the UE is tested using this function. (Refer to TS 34.109 [3] Logical Test Interface (FDD/TDD) Special conformance testing functions)

Unless otherwise stated the receiver characteristics are specified at the antenna connector of the UE. For UE(s) with an integral antenna only, a reference antenna with a gain of 0 dBi is assumed. UE with an integral antenna may be taken into account by converting these power levels into field strength requirements, assuming a 0 dBi gain antenna. Receiver characteristics for UE(s) with multiple antennas/antenna connectors are for further study.

The UE antenna performance has a significant impact on system performance, and minimum requirements on the antenna efficiency are therefore intended to be included in future versions of this specification. It is recognized that different requirements and test methods are likely to be required for the different types of UE.

All the parameters in clause 6 are defined using the DL reference measurement channel (12.2 kbps) specified in subclause C.3.3.

6.2 Reference sensitivity level

6.2.1 Definition and applicability

The reference sensitivity is the minimum receiver input power measured at the antenna connector at which the BER does not exceed the specific value.

The requirements in this subclause shall apply to all types of UTRA UE.

6.2.2 Conformance requirements

For the DL reference measurement channel 12.2 kBit/s specified in annex C, the BER shall not exceed 0.001 for the parameters specified in Table 6.2.2.

Table 6.2.2. Test parameters for reference sensitivity

Parameter	Level	Unit
$\frac{\Sigma DPCH_{Ec}}{I_{or}}$	0	dB
\hat{I}_{or}	-105	dBm/3.84 MHz

The reference for this requirement is TS 25.102 [1] subclause 7.3.

6.2.3 Test purpose

The test purpose is to verify the ability of the UE to receive a prescribed test signal at the lower end of the dynamic range under defined conditions (no interference, no multipath propagation) with a BER not exceeding a specified level. This test is also used as a reference case for other tests to allow the assessment of degradations due to various sources of interference.

6.2.4 Method of test

6.2.4.1 Initial conditions

- (1) Connect the SS to the UE antenna connector as shown in Figure A.3.
- (2) A call is set up according to the Generic call setup procedure..
- (3) Enter the UE into loopback test mode and start the loopback test.
- (4) The level of SS output signal measured at the UE antenna connector shall be -105 dBm.

6.2.4.2 Procedure

- (1) Measure the BER of DCH received from the UE at the SS.

6.2.5 Test requirements

The measured BER, derived in step (1), shall not exceed 0.001.

6.3 Maximum Input Level

6.3.1 Definition and applicability

This is defined as the maximum receiver input power, measured at the antenna connector, which does not degrade the specified BER performance.

The requirements in this subclause shall apply to all types of UTRA UE.

6.3.2 Conformance requirements

The BER shall not exceed 0,001 for the parameters specified in table 6.3.2.

Table 6.3.2: Maximum input level

Parameter	Level	Unit
$\frac{\Sigma DPCH_{Ec}}{I_{or}}$	-7	dB
\hat{I}_{or}	-25	dBm/3.84 MHz

The reference for this requirement is TS 25.102 [1] subclause 7.4.

6.3.3 Test purpose

The test purpose is to verify the ability of the UE to receive a prescribed test signal at the upper end of the dynamic range under defined conditions (no interference, no multipath propagation) with BER not exceeding a specified value.

6.3.4 Method of test

6.3.4.1 Initial conditions

- (1) Connect the SS to the UE antenna connector as shown in Figure A.3.
- (2) A call is set up according to the Generic call setup procedure.

(3) Enter the UE into loopback test mode and start the loopback test.

(4) The level of SS output signal measured at the UE antenna connector shall be according to table 6.3.2.

6.3.4.2 Procedure

Measure the BER of DCH received from the UE at the SS.

6.3.5 Test requirements

The measured BER, derived in step (1), shall not exceed 0,001.

6.4 Adjacent Channel Selectivity (ACS)

6.4.1 Definition and applicability

Adjacent Channel Selectivity is a measure of a receiver's ability to receive a wanted signal at its assigned channel frequency in the presence of an adjacent channel signal.

The requirements of this test apply to all UTRA UE.

6.4.2 Conformance requirements

For the UE of power class 2 and 3, the BER shall not exceed 0,001 for parameters specified in table 6.4.2. This test condition is equivalent to the ACS value 33 dB.

Table 6.4.2: Test parameters for Adjacent Channel Selectivity

Parameter	Unit	Level
$\frac{\Sigma DPCH_Ec}{I_{or}}$	dB	0
\hat{I}_{or}	dBm/3.84 MHz	-91
I_{oac}	dBm/3.84 MHz	-52
F_{uw} offset	MHz	+5 or -5

Explanatory note:

Within the reference sensitivity BER= 0.001 corresponds to a test signal = -105 dBm/3.84 MHz and a noise level -99 dBm /3.84 MHz BW (S/I -6 dB)

Within ACS BER=0.001 is directly verified

Known from the reference sensitivity, this corresponds to S/I -6dB in the wanted BW.

As a wanted signal of -91 dBm applied, an in-channel-interfering-signal of -85 dBm can be assumed.

Verifying a filter suppression of 33 dB indirectly, an adjacent-channel-interferer of -52 dBm is needed

The reference of this requirement is TS 25.102 [1] subclause 7.5.

6.4.3 Test purpose

The test purpose is to verify the ability of the UE-receiver to sufficiently suppress the interfering signal in the channel adjacent to the wanted channel.

6.4.4 Method of test

6.4.4.1 Initial conditions

- (1) Connect the SS and the interferer to the UE antenna connector as shown in Figure A.4.
- (2) A call is set up according to the Generic call setup procedure.
- (3) Enter the UE into loopback test mode and start the loopback test.
- (4) Set the signal generator to produce an interference signal. The interference signal shall be equivalent to a continuously running wideband CDMA signal with one code and chip frequency 3.84 Mchip/s and rolloff 0.22.

6.4.4.2 Procedure

- (1) Set the interference signal 5 MHz above the assigned channel frequency of the wanted signal.
- (2) Measure the BER of the wanted signal received from the UE at the SS.
- (3) Set the interference signal 5 MHz below the assigned channel frequency of the wanted signal and repeat (2).

6.4.5 Requirements

The measured BER, derived in step (2), shall not exceed 0,001.

6.5 Blocking Characteristics

6.5.1 Definition and applicability

The blocking characteristics is a measure of the receiver ability to receive a wanted signal at its assigned channel frequency in the presence of an unwanted interferer on frequencies other than those of the spurious response or the adjacent channels without this unwanted input signal causing a degradation of the performance of the receiver beyond a specified limit.. The blocking performance shall apply at all frequencies except those at which a spurious response occur.

The requirements of this test apply to all UTRA UE

6.5.2 Conformance requirements

The BER shall not exceed 0,001 for the parameters specified in table 6.5.2a and table 6.5.2b. For table 6.5.2b up to 24 exceptions are allowed for spurious response frequencies in each assigned frequency channel when measured using a 1MHz step size for the interference signal.

The reference for this requirement is 3G TS 25.102 clause 7.6.1

Table 6.5.2a: In-band blocking

Parameter	Offset 1	Offset 2	Unit
$\frac{\Sigma DPCH - Ec}{I_{or}}$	0	0	dB
\hat{I}_{or}	<REFSENS> + 3 dB	<REFSENS> + 3 dB	dBm/3.84 MHz
$I_{blocking}$ (modulated)	-56	-44	dBm/3.84 MHz
F_{uw} offset	+10 or -10	+15 or -15	MHz

Table 6.5.2b: Out of band blocking

Parameter	Band 1	Band 2	Band 3	Unit
$\frac{\Sigma DPCH - Ec}{I_{or}}$	0	0	0	dB
\hat{I}_{or}	<REFSENS> + 3 dB	<REFSENS> + 3 dB	<REFSENS> + 3 dB	dBm/3.84 MHz
$I_{blocking} (CW)$	-44	-30	-15	dBm
F_{uw} For operation in frequency bands as defined in subclause 4.2(a)	1840 <f <1885 1935 <f <1995 2040 <f <2085	1815 <f <1840 2085 <f <2110	1 <f <1815 2110 <f <12750	MHz
F_{uw} For operation in frequency bands as defined in subclause 4.2(b)	1790 <f < 1835 2005 <f < 2050	1765 <f < 1790 2050 <f < 2075	1 <f < 1765 2075 <f < 12750	MHz
F_{uw} For operation in frequency bands as defined in subclause 4.2(c)	1850 <f < 1895 1945 <f < 1990	1825 <f < 1850 1990 <f < 2015	1 <f < 1825 2015 <f < 12750	MHz

- Note:
1. For operation referenced in 4.2(a), from 1885 <f < 1900 MHz, 1920 <f < 1935 MHz, 1995 <f < 2010 MHz and 2025 <f < 2040 MHz, the appropriate in-band blocking or adjacent channel selectivity in section 6.5.2. shall be applied.
 2. For operation referenced in 4.2(b), from 1835 <f < 1850 MHz and 1990 <f < 2005 MHz, the appropriate in-band blocking or adjacent channel selectivity in section 6.5.2. shall be applied.
 3. For operation referenced in 4.2(c), from 1895 <f < 1910 MHz and 1930 <f < 1945 MHz, the appropriate in-band blocking or adjacent channel selectivity in section 6.5.2. shall be applied.

6.5.3 Test purpose

"The test stresses the ability of the UE receiver to withstand high-level interference from unwanted signals at frequency offsets of 10 MHz or more, without undue degradation of its sensitivity."

6.5.4 Method of test

6.5.4.1 Initial conditions

- (1) Connect the SS and the interfering Signal generator to the antenna connector as shown in Figure A.5.
- (2) A call is set up according to the Generic call setup procedure (3) Enter the UE into loopback test mode and start the loopback test.

6.5.4.2 Procedure

- (1) The wanted signal frequency channel is set into the middle of the band.
- (2) The interfering Signal Generator is stepped through the frequency range indicated in table 6.5.2.a. with a step size of 1 MHz.
- (3) The interference signal shall be equivalent to a continuously running wideband CDMA signal with one code and chip frequency 3.84 Mchip/s and rolloff 0.22.

- (4) Measure the BER of the wanted signal received from the UE at the SS for each step of the interferer.
- (5) Repeat the inband blocking for wanted frequency channels low-band and high-band.
- (6) The wanted signal frequency channel is set into the middle of the band.
- (7) The interfering Signal Generator is stepped through the frequency range indicated in table 6.4.2.b. with a step size of 1 MHz.
- (8) The interference signal is a CW signal.
- (9) Measure the BER of the wanted signal received from the UE at the SS for each step of the interferer.

NOTE: Due to the large amount of time-consuming BER tests it is recommended to speed up a single BER test by reducing the 0.001-BER confidence level [10 000 bits under test or 10 errors] for screening the critical frequencies. Critical frequencies must be identified using standard BER confidence level. [30 000 bits or 30 errors].

6.5.5 Test requirements

The measured BER, derived in step (4) and (5), shall not exceed 0,001 (without exception).

The measured BER, derived in step (9), shall not exceed 0,001 except for up to 24 different frequencies of the interfering signal. These frequencies are further processed in subclause 5.6 Spurious response.

6.6 Spurious Response

6.6.1 Definition and applicability

Spurious response is a measure of the receiver's ability to receive a wanted signal on its assigned channel frequency without exceeding a given degradation due to the presence of an unwanted CW interfering signal at any other frequency at which a response is obtained i.e. for which the blocking limit is not met.

The requirements of this test apply to all types of UTRA for the UE.

6.6.2 Conformance requirements

The BER shall not exceed 0,001 for the parameters specified in table 6.6.2.

The reference for this requirement is 3G TS 25.102 clause 7.7.1

Table 6.6.2: Spurious Response

Parameter	Value	Unit
$\frac{\Sigma DPCH - Ec}{I_{or}}$	0 dB	dB
\hat{I}_o	<REFSENS> + 3 dB	dBm/3.84 MHz
$I_{\text{blocking (CW)}}$	-44	dBm
F_{uw}	Spurious response frequencies	MHz

6.6.3 Test purpose

Spurious response frequencies, identified in the blocking test, are measured against a less stringent test requirement. The test stresses the ability of the receiver to withstand high level interference signals without undue degradation of its sensitivity due to the receiver's frequency conversion concept.

6.6.4 Method of test

6.6.4.1 Initial conditions

- (1) Connect the SS and the unwanted signal to the UE antenna connector as shown in Figure A.6.
- (2) A call is set up according to the Generic call setup procedure. (3) Enter the UE into loopback test mode and start the loopback test.

6.6.4.2 Procedure

- (1) Repeat the wanted signal frequency setting from the blocking test. Set the level according to table 6.6.2.
- (2) Repeat the frequency settings of the interferer signal, at which the blocking test failed. Set the level according to table 6.6.2.
- (3) Measure the BER of DCH received from the UE at the SS for each of the settings (1) and (2).

6.6.5 Test requirements

The measured BER, derived in step (3), shall not exceed 0,001.

6.7 Intermodulation Characteristics

6.7.1 Definition and applicability

Third and higher order mixing of the two interfering RF signals can produce an interfering signal in the band of the desired channel. Intermodulation response rejection is a measure of the capability of the receiver to receive a wanted signal on its assigned channel frequency in the presence of two or more interfering signals which have a specific frequency relationship to the wanted signal.

The requirements of this test shall apply to all UTRA UE.

6.7.2 Conformance requirements

The BER shall not exceed 0,001 for the parameters specified in table 6.7.2

The reference for this requirement is 3G TS 25.102 subclause 7.8.1.

Table 6.7.2: Receive intermodulation characteristics

Parameter	Value	Unit
$\frac{\Sigma DPCH_Ec}{I_{or}}$	0	dB
\hat{I}_{or} Wanted Signal Level	<REFSENS> + 3 dB	dBm/3.84 MHz
$I_{ouw1(CW)}$	-46	dBm
$I_{ouw2(modulated)}$	-46	dBm/3.84 MHz
$F_{uw1(CW)}$	10	MHz
$F_{uw2(Modulated)}$	20	MHz

6.7.3 Test purpose

The test stresses the ability of the receiver to withstand two or more high level interference signals without undue degradation of its sensitivity due to the receiver's non-linear elements.

6.7.4 Method of test

6.7.4.1 Initial conditions

- (1) Connect the SS and the unwanted signals to the UE antenna connector as shown in Figure A.7.
- (2) A call is set up according to the Generic call setup procedure.
- (3) Enter the UE into loopback test mode and start the loopback test.

6.7.4.2 Procedure

- (1) Set the interfering signals as indicated in table 6.7.2. with positive offset with respect to the wanted signal.
- (2) Measure the BER of DCH received from the UE at the SS.
- (3) Set the interfering signals as indicated in table 6.7.2. with negative offset with respect to the wanted signal and repeat (2).

6.7.5 Test requirements

The measured BER, derived in step (2) and (3), shall not exceed 0,001.

6.8 Spurious Emissions

6.8.1 Definition and applicability

The Spurious Emissions Power is the power of emissions generated or amplified in a receiver that appear at the UE antenna connector.

The requirements of this test are applicable for all UTRA UE.

6.8.2 Conformance requirements

The power of any spurious emission shall not exceed:

Table 6.8.2.: Receiver spurious emission requirements

Band	Maximum level	Measurement Bandwidth	Note
9 kHz – 1 GHz	-57 dBm	100 kHz	
1 GHz – 1.9 GHz and 1.92 GHz – 2.01 GHz and 2.025 GHz – 2.11 GHz	-47 dBm	1 MHz	With the exception of frequencies between 12.5MHz below the first carrier frequency and 12.5MHz above the last carrier frequency used by the UE.
1.9 GHz – 1.92 GHz and 2.01 GHz – 2.025 GHz and 2.11 GHz – 2.170 GHz	-60 dBm	3.84 MHz	With the exception of frequencies between 12.5MHz below the first carrier frequency and 12.5MHz above the last carrier frequency used by the UE.
2.170 GHz – 12.75 GHz	-47 dBm	1 MHz	

The reference for this requirement is TS 25.102 [1] subclause 7.9.

6.8.3 Test purpose

The test purpose is to verify the UE's ability to limit interference caused by receiver spurious emissions to the own and the other systems. The test requirements are tighter than in 5.5.3 ((TX) Spurious Emissions) because the time of Receive-Only-Operation is generally much longer than RX-TX-Operation.

6.8.4 Method of test

6.8.4.1 Initial conditions

- (1) Connect the measurement equipment to the UE antenna connector according to figure A.8.
- (2) The measurement equipment shall measure power through
 - a 100 kHz filter with a approximately gaussian filter-characteristic (typical spectrum analyzer), or
 - a 1MHz filter with a approximately gaussian filter-characteristic (typical spectrum analyzer), or
 - a matched filter with a bandwidth equal to the chip frequency 3.84 Mchip/s and rolloff 0.22.
- (3) Enable the UE receiver and set Cell Search Mode on a PCCPCH. Since there is no down link signal, the UE should not pass the Cell Search mode.

<Editor's Note: The method to set Cell Search Mode should be defined.>

6.8.4.2 Procedure

Measure the power of spurious emissions by covering the frequency ranges of table 6.8.2. Cover the UTRA/TDD and UTRA/FDD UE receive band in contiguous steps of [200 kHz]. Cover the other frequency ranges in contiguous steps of 100 kHz. Apply the corresponding filters of table 6.8.2.. The step duration shall be sufficient slow to capture intermittent spurious emissions.

6.8.5 Test requirements

The spurious emissions shall be according to subclause 6.8.2.

7 Performance Requirements

7.1 General

The performance requirements for the UE in this section is specified for the measurement channels specified in annex C and the test environments specified in annex D.

7.2 Demodulation in static propagation conditions

7.2.1 Demodulation of DCH

7.2.1.1 Definition and applicability

The performance requirement of DCH in static propagation conditions is determined by the maximum Block Error Ratio (BLER). The BLER is specified for each individual data rate of the DCH. DCH is mapped into the Dedicated Physical Channel (DPCH).

The UE shall be tested only according to the datarates, supported. The data-rate-corresponding requirements shall apply to the UE.

7.2.1.2 Conformance requirements

For the parameters specified in table 7.2.1.2a the BLER shall not exceed the piece-wise linear BLER curve specified in table 7.2.1.2b. . These requirements are applicable for TFCS size 16.

The reference for this requirement is 3G TS 25.102 clause 8.2.1.1.

Table 7.2.1.2a: DCH parameters in static propagation conditions

Parameters	Unit	Test 1	Test 2	Test 3	Test 4
$\frac{\Sigma DPCH - E_c}{I_{or}}$	dB	-6	-3	0	0
I_{oc}	dBm/3.84 MHz	-60			
Information Data Rate	kbps	12.2	64	144	384

Table 7.2.1.2.b: Performance requirements in AWGN channel

Test Number	$\frac{\hat{I}_{or}}{I_{oc}}$ [dB]	BLER
1	0.1	10^{-2}
2	2.3	10^{-1}
	2.6	10^{-2}
3	2.2	10^{-1}
	2.4	10^{-2}
4	1.6	10^{-1}
	1.8	10^{-2}

7.2.1.3 Test purpose

While the receiver tests in clause 6 aims for the RF hardware, this performance requirement aims for the receiver's signal processing.

The test purpose is to verify the ability of the receiver to receive a predefined test signal, representing a static propagation channel for the wanted and for the co-channel signals from serving and adjacent cells, with a block error ratio (BLER) not exceeding a specified value.

7.2.1.4 Method of test

7.2.1.4.1 Initial conditions

- (1) Connect the SS, AWGN Generator and additional components to the UE antenna connector as shown in Figure A.9.
- (2) A call is set up according to the Generic call setup procedure. The characteristic of the call shall be according to the DL reference measurement channels (12.2 kbit/s)(64 kbit/s), (144 kbit/s), and (384 kbit/s) specified in annex C.
- (3) Enter the UE into loopback test mode and start the loopback test. (test 1) and/or activate the Ack/Nack test mode (test 1 to test 4).
- (4) The levels of the wanted signal and the co-channel signals are set according to table 7.2.1.2a and b.

7.2.1.4.2 Procedure

Measure the BLER of DCH received from the UE at the SS for all 4 tests.

7.2.1.5 Test requirements

The measured BLER shall not exceed the values indicated in table 7.2.1.2b.

7.3 Demodulation of DCH in multipath fading conditions

7.3.1 Multipath fading Case 1

7.3.1.1 Definition and applicability

The performance requirement of DCH is determined by the maximum Block Error Ratio (BLER). The BLER is specified for each individual data ratio of the DCH. DCH is mapped into the Dedicated Physical Channel (DPCH).

The UE shall be tested only according to the data ratios, supported. The data-ratio-corresponding requirements shall apply to the UE.

7.3.1.2 Conformance requirements

For the parameters specified in table 7.3.1.2a the BLER shall not exceed the piece-wise linear BLER curve specified in table 7.3.1.2b. . These requirements are applicable for TFCS size 16.

The reference for this requirement is 3G TS 25.102 clause 8.3.1.1.

Table 7.3.1.2a: DCH parameters in multipath Case 1 channel

Parameters	Unit	Test 1	Test 2	Test 3	Test 4
$\frac{\Sigma DPCH - E_c}{I_{or}}$	dB	-6	-3	0	0
I_{oc}	dBm/3.84 MHz	-60			
Information Data Ratio	kbps	12.2	64	144	384

Table 7.3.1.2b: Performance requirements in multipath Case 1 channel

Test Number	$\frac{\hat{I}_{or}}{I_{oc}}$ [dB]	BLER
1	13.5	10^{-2}
2	13.3	10^{-1}
	19.6	10^{-2}
3	13.3	10^{-1}
	19.7	10^{-2}
4	13.5	10^{-1}
	20.2	10^{-2}

7.3.1.3 Test purpose

While the receiver tests in clause 6 aims for the RF hardware, this performance requirement aims for the receiver's signal processing.

The test purpose is to verify the ability of the receiver to receive a predefined test signal, representing a multipath propagation channel for the wanted and for the co-channel signals from serving and adjacent cells, with a block error ratio (BLER) not exceeding a specified value.

7.3.1.4 Method of test

7.3.1.4.1 Initial conditions

- (1) Connect the SS, , the fading simulator, the AWGN generator and additional components to the UE antenna connector as shown in Figure A.10.
- (2) A call is set up according to the Generic call setup procedure. The characteristic of the call shall be according to the DL reference measurement channels (12.2 kbit/s), (64 kbit/s), (144 kbit/s), and (384 kbit/s) specified in annex C.

- (3) Enter the UE into loopback test mode and start the loopback test. (test 1) and/or activate the Ack/Nack test mode (test 1 to test 4).
- (4) The levels of the wanted signal and the co-channel signals are set according to table 7.3.1.2a and b.

7.3.1.4.2 Procedure

Measure the BLER of DCH received from the UE at the SS for all 4 tests.

7.3.1.5 Test requirements

The measured BLER shall not exceed the values indicated in table 7.3.1.2b.

7.3.2 Multipath fading Case 2

7.3.2.1 Definition and applicability

The performance requirement of DCH is determined by the maximum Block Error Ratio (BLER). The BLER is specified for each individual data rate of the DCH. DCH is mapped into the Dedicated Physical Channel (DPCH).

The UE shall be tested only according to the datarates, supported. The data-rate-corresponding requirements shall apply to the UE.

7.3.2.2 Conformance requirement

For the parameters specified in table 7.3.2.2a the BLER should not exceed the piece-wise linear BLER curve specified in table 7.3.2.2b. . These requirements are applicable for TFCS size 16.

The reference for this requirement is 3G TS 25.102 clause 8.3.2.1

Table 7.3.2.2a: DCH parameters in multipath Case 2 channel

Parameters	Unit	Test 1	Test 2	Test 3	Test 4
$\frac{\Sigma DPCH - E_c}{I_{or}}$	DB	-3	0	0	0
I_{oc}	dBm/3.84 MHz	-60			
Information Data Rate	kbps	12.2	64	144	384

Table 7.3.2.2b: Performance requirements in multipath Case 2 channel

Test Number	$\frac{\hat{I}_{or}}{I_{oc}}$ [dB]	BLER
1	5.5	10^{-2}
2	5.8	10^{-1}
	9.7	10^{-2}
3	9.5	10^{-1}
	13.2	10^{-2}
4	8.5	10^{-1}
	12.6	10^{-2}

7.3.2.3 Test purpose

While the receiver tests in clause 6 aims for the RF hardware, this performance requirement aims for the receiver's signal processing.

The test purpose is to verify the ability of the receiver to receive a predefined test signal, representing a multipath propagation channel for the wanted and for the co-channel signals from serving and adjacent cells, with a block error ratio (BLER) not exceeding a specified value.

7.3.2.4 Method of test

7.3.2.4.1 Initial conditions

- (1) Connect the SS, the fading simulator, the AWGN generator and additional components to the UE antenna connector as shown in Figure A.10.
- (2) A call is set up according to the Generic call setup procedure. The characteristic of the call shall be according to the DL reference measurement channels (12.2 kbit/s)(64 kbit/s), (144 kbit/s), and (384 kbit/s) specified in annex C.
- (3) Enter the UE into loopback test mode and start the loopback test. (test 1) and/or activate the Ack/Nack test mode (test 1 to test 4).
- (4) The levels of the wanted signal and the co-channel signals are set according to table 7.3.2.2a and b.

7.3.2.4.2 Procedure

Measure the BLER of DCH received from the UE at the SS for all 4 tests.

7.3.2.5 Test requirements

The measured BLER shall not exceed the values indicated in table 7.3.2.2b.

7.3.3 Multipath fading Case 3

7.3.3.1 Definition and applicability

The performance requirement of DCH is determined by the maximum Block Error Ratio (BLER). The BLER is specified for each individual data rate of the DCH. DCH is mapped into the Dedicated Physical Channel (DPCH).

The UE shall be tested only according to the datarates, supported. The data-rate-corresponding requirements shall apply to the UE.

7.3.3.2 Conformance requirements

For the parameters specified in table 7.3.3.2a the BLER should not exceed the piece-wise linear BLER curve specified in table 7.3.3.2b. . These requirements are applicable for TFCS size 16.

The reference for this requirement is 3G TS 25.102 clause 8.3.3.1

Table 7.3.3.2a: DCH parameters in multipath Case 3 channel

Parameters	Unit	Test 1	Test 2	Test 3	Test 4
$\frac{\Sigma DPCH - E_c}{I_{or}}$	dB	-3	0	0	0
I_{oc}	dBm/3.84 MHz	-60			
Information Data Rate	kbps	12.2	64	144	384

Table 7.3.3.2b: Performance requirements in multipath Case 3 channel

Test Number	$\frac{\hat{I}_{or}}{I_{oc}}$ [dB]	BLER
12.2 kbps	4.7	10^{-2}
64 kbps	5.2	10^{-1}
	8.4	10^{-2}
	12.1	10^{-3}
144 kbps	11.7	10^{-1}
	15.2	10^{-2}
	17.8	10^{-3}
384 kbps	8.2	10^{-1}
	11.3	10^{-2}
	13.0	10^{-3}

7.3.3.3 Test purpose

While the receiver tests in clause 6 aims for the RF hardware, this performance requirement aims for the receiver's signal processing.

The test purpose is to verify the ability of the receiver to receive a predefined test signal, representing a multipath propagation channel for the wanted and for the co-channel signals from serving and adjacent cells, with a block error ratio (BLER) not exceeding a specified value.

7.3.3.4 Method of test

7.3.3.4.1 Initial conditions

- (1) Connect the SS, the fading simulator, the AWGN generator and additional components to the UE antenna connector as shown in Figure A.10.
- (2) A call is set up according to the Generic call setup procedure. The characteristic of the call shall be according to the DL reference measurement channels (12.2 kbit/s), (64 kbit/s), (144 kbit/s), and (384 kbit/s) specified in annex C.
- (3) Enter the UE into loopback test mode and start the loopback test. (test 1) and/or activate the Ack/Nack test mode (test 1 to test 4).
- (4) The levels of the wanted signal and the co-channel signals are set according to table 7.3.3.2a and b.

7.3.3.4.2 Procedure

Measure the BLER of DCH received from the UE at the SS for all 4 tests.

7.3.3.5 Test requirements

The measured BLER shall not exceed the values indicated in table 7.3.3.2.b.

7.4 Base station transmit diversity mode

7.4.1 Demodulation of BCH in Block STTD mode

The performance requirement of BCH is determined by the maximum Block Error Rate (BLER). The BLER is specified for the BCH. BCH is mapped into the Primary Common Control Physical Channel (P-CCPCH).

7.4.1.1 Conformance requirements

For the parameters specified in Table 7.4.1.1.a the BLER should not exceed the BLER specified in Table 7.4.1.1.b

The reference for this requirement is 3G TS 25.102 clause 8.4.1.

Table 7.4.1.1.a: P-CCPCH parameters in multipath Case 1 channel

Parameters	Unit	Test 1
$\frac{P_{CCPCH} - E_c}{I_{or}}$	dB	-3
I	dBm/3.84 MHz	-60
Information Data Rate	Kbps	12.3

Table 7.4.1.1.b: Performance requirements in multipath Case 1 channel.

Test Number	$\frac{\hat{I}_{or}}{I_{oc}}$ [dB]	BLER
1	8.4	10^{-2}

-
- 8 Requirements for Support of RRM
 - 8.1 General
 - 8.2 Idle Mode Tasks
 - 8.2.1 Introduction
 - 8.2.2 RF Cell Selection Scenario
 - 8.2.2.1 Requirements for Cell Selection single carrier single cell case
 - 8.2.2.2 Requirements for Cell Selection multicarrier carrier multi cell case
 - 8.2.3 RF Cell Re-Selection Scenario
 - 8.2.3.1 Requirements for Cell Re-Selection single carrier multi cell case
 - 8.2.4 PLMN Selection and Re-Selection Scenario
 - 8.2.5 Location Registration Scenario
 - 8.3 RRC Connection mobility
 - 8.3.1 Handover
 - 8.3.1.1 Introduction
 - 8.3.1.2 Handover 3G to 3G
 - 8.3.1.2.1 TDD/TDD Handover
 - 8.3.1.2.2 TDD/FDD Handover
 - 8.3.1.3 Handover 3G to 2G
 - 8.3.1.3.1 Handover to GSM
 - 8.3.2 Radio Link Management
 - 8.3.2.1 Link adaptation
 - 8.3.3 Cell Update
 - 8.3.4 URA Update

- 8.4 RRC Connection Control
 - 8.4.1 Radio Access Bearer Control
- 8.5 Dynamic Channel Allocation
- 8.6 Timing characteristics
 - 8.6.1 Timing Advance (TA) Requirements
- 8.7 Measurements Performance Requirements
 - 8.7.1 Measurements Performance for UE

Annex A (informative): Connection Diagrams

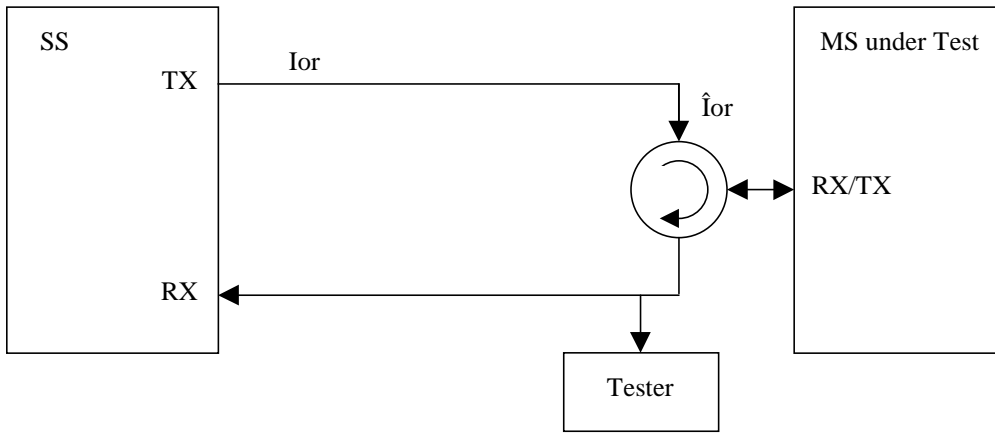

Figure A.1: Connection for Basic TX Test

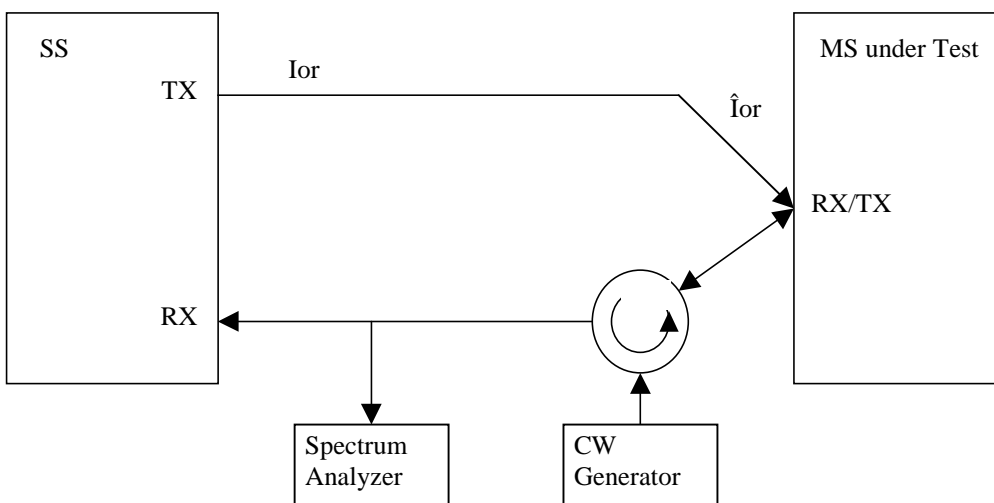

Figure A.2: Connection for TX Intermodulation Test

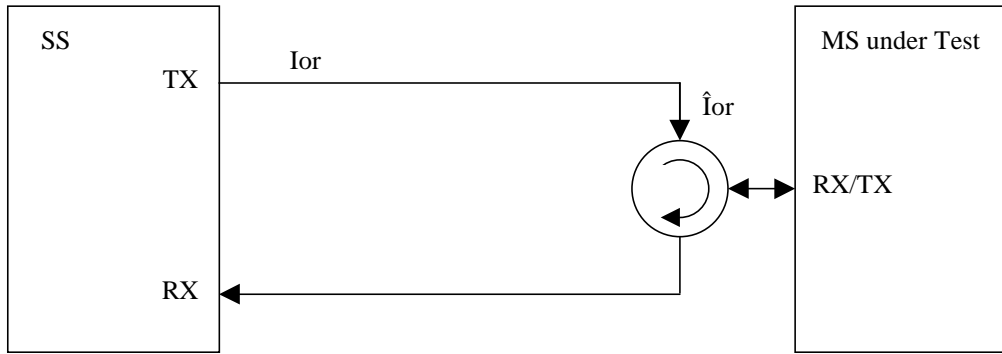

Figure A.3: Connection for Basic RX Test

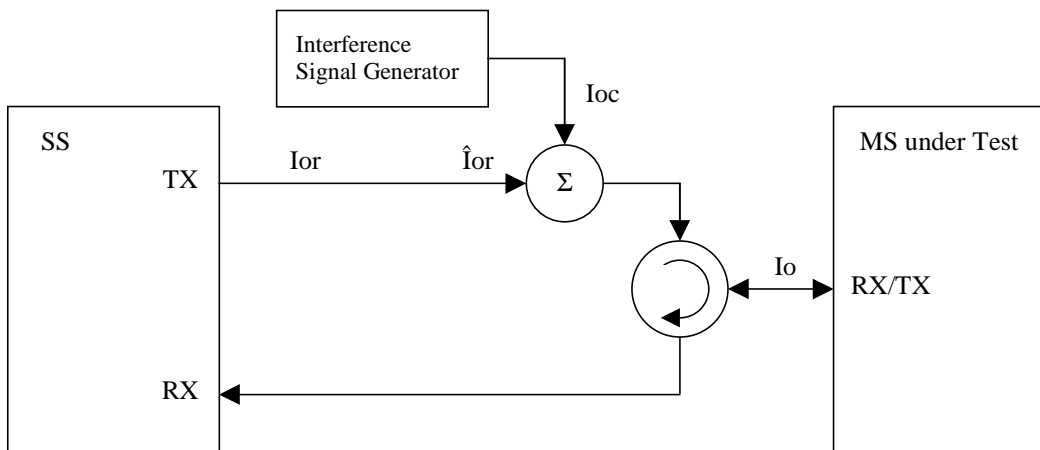

Figure A.4: Connection for RX Test with Interference

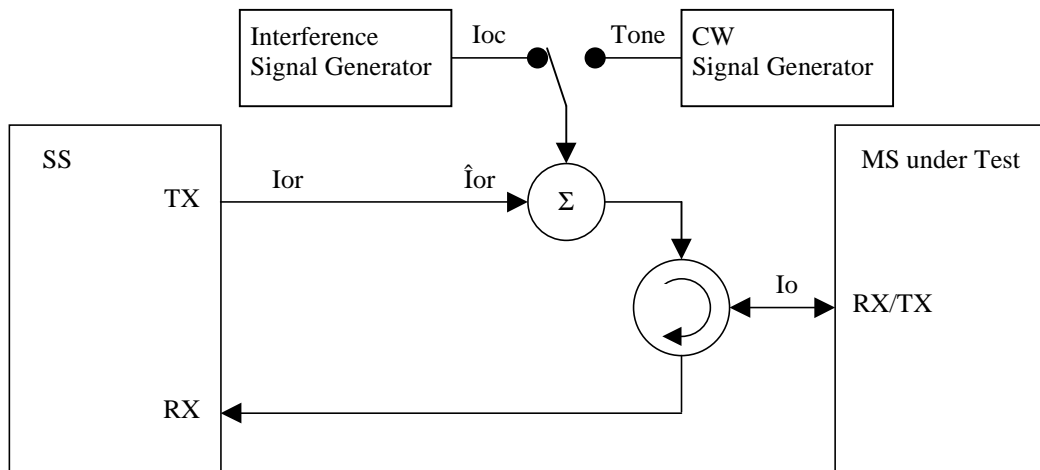

Figure A.5: Connection for RX Test with Interference or additional CW

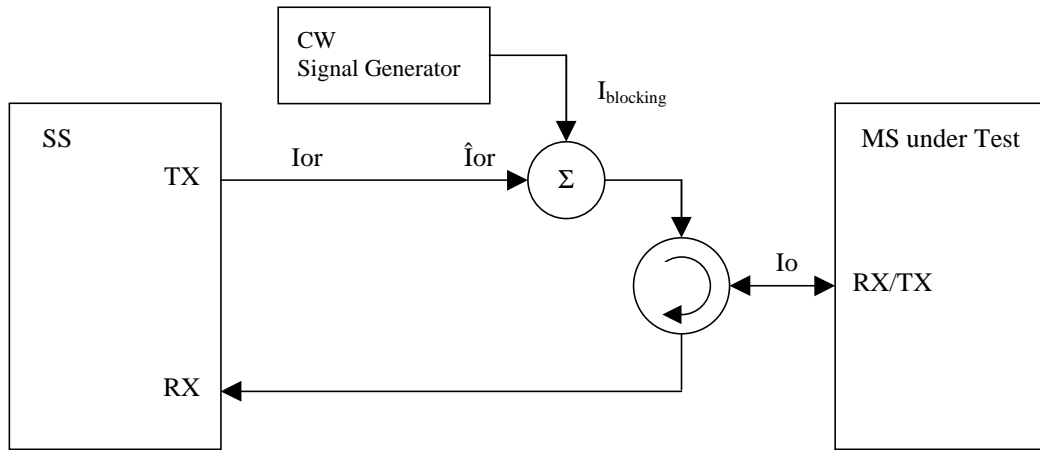

Figure A.6: Connection for RX Test with additional CW

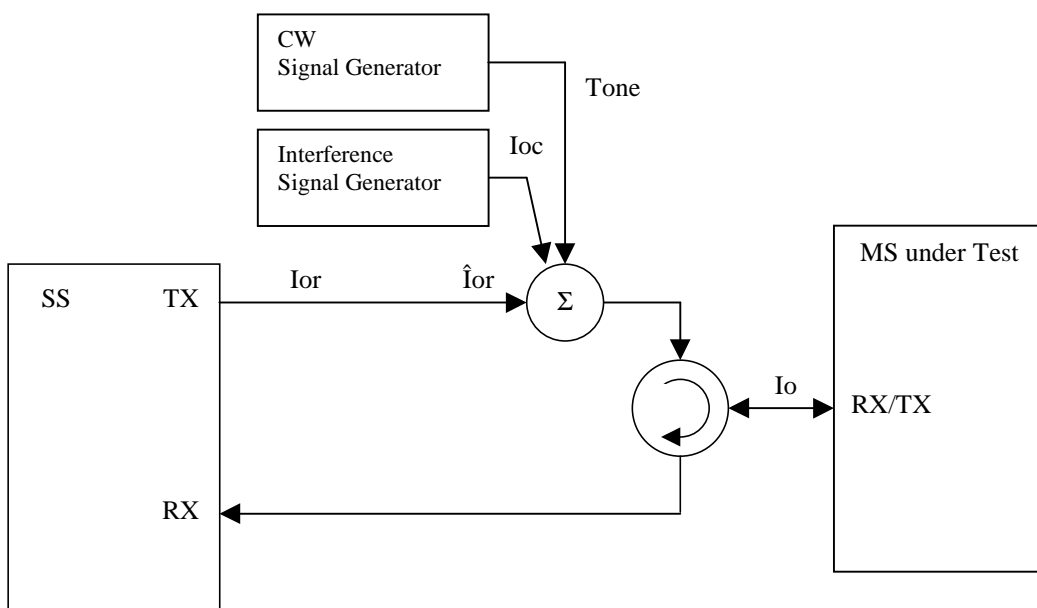

Figure A.7: Connection for RX Test with both Interference and additional CW



Figure A.8: Connection for Spurious Emission Test

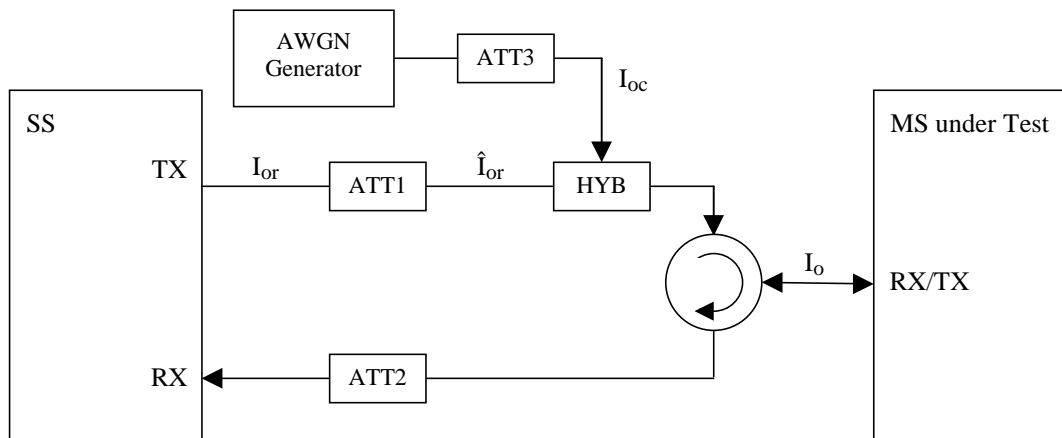

Figure A.9: Connection for Static Channel Test

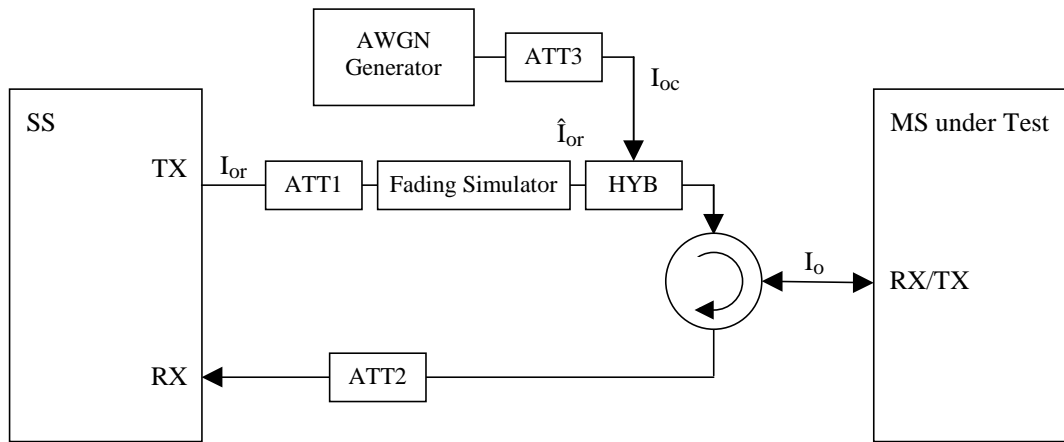

Figure A.10: Connection for Multiple Fading Channel Test

Annex B (normative) Global In-Channel TX-Test

B.1 General

The global in-channel Tx test enables the measurement of all relevant parameters that describe the in-channel quality of the output signal of the Tx under test in a single measurement process.

The objective of this Annex is to list the results that shall be available from the Global In-Channel TX-Test. To aid understanding, an example algorithmic description of the measurement process is provided. It is not intended that this particular method is required. It is however required that any algorithm that is used for In-Channel TX tests should deliver the required results with the required accuracy.

All notes referred in the various subclauses of B.2 are put together in B.3

B.2 Definition of the process

B.2.1 Basic principle

The process is based on the comparison of the actual **output signal of the TX under test**, received by an ideal receiver, with a **reference signal**, that is generated by the measuring equipment and represents an ideal error free received signal. All signals are represented as equivalent (generally complex) baseband signals.

B.2.2 Output signal of the TX under test

The output signal of the TX under test is acquired by the measuring equipment, filtered by a matched filter (RRC 0.22, correct in shape and in position on the frequency axis) and stored at one sample per chip at the Inter-Symbol-Interference free instants.

The following form represents the physical signal in the entire measurement interval:

one vector **Z**, containing $N = ns \times sf + ma$ complex samples;

with

ns: number of symbols in the measurement interval;

sf: number of chips per symbol. (sf: spreading factor) (see Note: Symbol length)

ma: number of midamble chips (only in TDD)

B.2.3 Reference signal

The reference signal is constructed by the measuring equipment according to the relevant TX specifications.

It is filtered by the same matched filter, mentioned in B.2.2., and stored at the Inter-Symbol-Interference free instants. The following form represents the reference signal in the entire measurement interval:

one vector **R**, containing $N = ns \times sf + ma$ complex samples;

ns, sf, ma: see B.2.2

B.2.4 void

B.2.5 Classification of measurement results

The measurement results achieved by the global in-channel TX test can be classified into two types:

Results of type “deviation”, where the error-free parameter has a non-zero magnitude. (These are the parameters that quantify the integral physical characteristic of the signal). These parameters are:

RF Frequency	
Power	(in case of single code)
Code Domain Power	(in case of multi code)
Timing	(only for UE)
(Additional parameters: see Note: Deviation)	

Results of type “residual”, where the error-free parameter has value zero. (These are the parameters that quantify the error values of the measured signal, whose ideal magnitude is zero). These parameters are:

Error Vector Magnitude (EVM);
Peak Code Domain Error (PCDE).
(Additional parameters: see Note residual)

B.2.6 Process definition to achieve results of type “deviation”

The reference signal (**R**; see subclause B.2.3) is varied with respect to the parameters mentioned in subclause B.2.5 under "results of type deviation" in order to achieve best fit with the recorded signal under test (**Z**; see subclause B.2.2). Best fit is achieved when the RMS difference value between the signal under test and the varied reference signal is an absolute minimum. The varied reference signal, after the best fit process, will be called **R'**.

The varying parameters, leading to **R'** represent directly the wanted results of type “deviation”. These measurement parameters are expressed as deviation from the reference value with units same as the reference value.

In case of multi code, the type-“deviation”-parameters (frequency, timing and (RF-phase)) are varied commonly for all codes such that the process returns one frequency-deviation, one timing deviation, (one RF-phase –deviation).

(These parameters are not varied on the individual codes signals such that the process returns k frequency errors... . (k: number of codes)).

The only type-“deviation”-parameters varied individually are code powers such that the process returns k code power deviations (k: number of codes).

B.2.7 Process definition to achieve results of type “residual”

The difference between the varied reference signal (**R'**; see subclause B.2.6.) and the TX signal under test (**Z**; see subclause B.2.2) is the error vector **E** versus time:

$$\mathbf{E} = \mathbf{Z} - \mathbf{R}'.$$

Depending on the parameter to be evaluated, it is appropriate to represent **E** in one of the following two different forms:

Form EVM (representing the physical error signal in the entire measurement interval)

One vector **E**, containing $N = n_s \times s_f + m_a$ complex samples;

n_s , s_f , m_a : see B.2.2

Form PCDE (derived from Form EVM by separating the samples into symbol intervals)

ns time-sequential vectors **e** with sf complex samples comprising one symbol interval.

E gives results of type “residual” applying the two algorithms defined in subclauses B 2.7.1 and B 2.7.2.

B.2.7.1 Error Vector Magnitude (EVM)

The Error Vector Magnitude EVM is calculated according to the following steps:

- (1) Take the error vector **E** defined in subclause B.2.7 (Form EVM) and calculate the RMS value of **E**; the result will be called RMS(**E**).
- (2) Take the reference vector **R** defined in subclause B.2.3 and calculate the RMS value of **R**; the result will be called RMS(**R**).
- (3) Calculate EVM according to:

$$EVM = \frac{RMS(\mathbf{E})}{RMS(\mathbf{R})} \times 100\% \quad (\text{here, EVM is relative and expressed in \%})$$

(see note TDD)

B.2.7.2 Peak Code Domain Error (PCDE)

The Peak Code Domain Error is calculated according to the following steps:

- (1) Take the error vectors **e** defined in subclause B.2.7 (Form PCDE)
- (2) Take the orthogonal vectors of the channelisation - code set **C** (all codes belonging to one spreading factor) as defined in TS 25.213 and TS 25.223 (range +1, -1). (see Note: Symbol length)
- (3) To achieve meaningful results it is necessary to descramble **e**, leading to **e'** (see Note1: Scrambling code)
- (4) Calculate the inner product of **e'** with **C**. Do this for all symbols of the measurement interval and for all codes in the code space.
This gives an array of format k x ns, each value representing an error-vector representing a specific symbol and a specific code, which can be exploited in a variety of ways.

k: number of codes

ns: number of symbols in the measurement interval

- (5) Calculate k RMS values, each RMS value unifying ns symbols within one code.
(These values can be called "*Absolute CodeEVMs*" [Volt].)
- (6) Find the peak value among the k "*Absolute CodeEVMs*".
(This value can be called "*Absolute PeakCodeEVM*" [Volt].)
- (7) Calculate PCDE according to:

$$10 \cdot \lg \frac{(\textit{Absolute PeakCodeEVM})^2}{(RMS(\mathbf{R}))^2} \quad \text{dB} \quad (\text{a relative value in dB}).$$

(see Note: Denominator)

(see Note2: Scrambling code)

(see Note IQ)

(see Note TDD)

(see Note Synch channel)

B.3 Notes

Note: Symbol length)

A general code multiplexed signal is multicode and multirate. In order to avoid unnecessary complexity, the measurement applications use a unique symbol-length, corresponding to a spreading factor, regardless of the really intended spreading factor. Nevertheless the complexity with a multicode / multirate signal can be mastered by introducing appropriate definitions.

Note: Deviation)

It is conceivable to regard more parameters as type „deviation“ e.g. Chip frequency and RF-phase.

As chip-frequency and RF-frequency are linked together by a statement in the core specifications [1] it is sufficient to process RF frequency only.

A parameter RF-phase must be varied within the best fit process (B 2.6.). Although necessary, this parameter-variation doesn't describe any error, as the modulation schemes used in the system don't depend on an absolute RF-phase.

Note: residual)

It is conceivable to regard more parameters as type „residual“ e.g. IQ origin offset. As it is not the intention of the test to separate for different error sources, but to quantify the quality of the signal, all such parameters are not extracted by the best fit process, instead remain part of EVM and PCDE.

Note: Denominator)

If the denominator stems from mutual time shifted signals of different code powers, (e.g. BS, FDD) the measurement result PCDE should be expressed absolutely instead.

Note1: Scrambling Code)

In general a TX signal under test can use more than one scrambling code. Note that PCDE is processed regarding the unused channelisation - codes as well. In order to know which scrambling code shall be applied on unused channelisation - codes, it is necessary to restrict the test conditions: TX signal under test shall use exactly one scrambling code.

Note2 Scrambling Code)

To interpret the measurement results in practice it should be kept in mind that erroneous code power on unused codes is generally de-scrambled differently under test conditions and under real life conditions, whereas erroneous code power on used codes is generally de-scrambled equally under test conditions and under real life conditions. It might be indicated if a used or unused code hits PCDE.

Note IQ)

As in FDD/uplink each code can be used twice, on the I and on the Q channel, the measurement result may indicate on which channel (I or Q) PCDE occurs.

Note TDD)

EVM covers the midamble part as well as the data part; however PCDE disregards the midamble part.

Note: Synch Channel)

A BS signal contains a physical synch channel, which is non orthogonal, related to the other DPCHs. In this context note: The code channel bearing the result of PCDE is exactly one of the DPCHs (never the synch channel). The origin of PCDE (erroneous code power) can be any DPCH and/or the synch channel.

Annex C (normative): Measurement channels

C.1 General

C.2 UL Reference measurement channels

C.2.1 UL reference measurement channel (12.2 kbps)

Parameter	
Information data rate	12.2 kbps
RU's allocated	2 RU
Midamble	512 chips
Interleaving	20 ms
Power control	2 Bit/user
TFCI	16 Bit/user
Inband signalling DCCH	2 kbps
Puncturing level at Code rate 1/3 : DCH / DCCH	5% / 0%

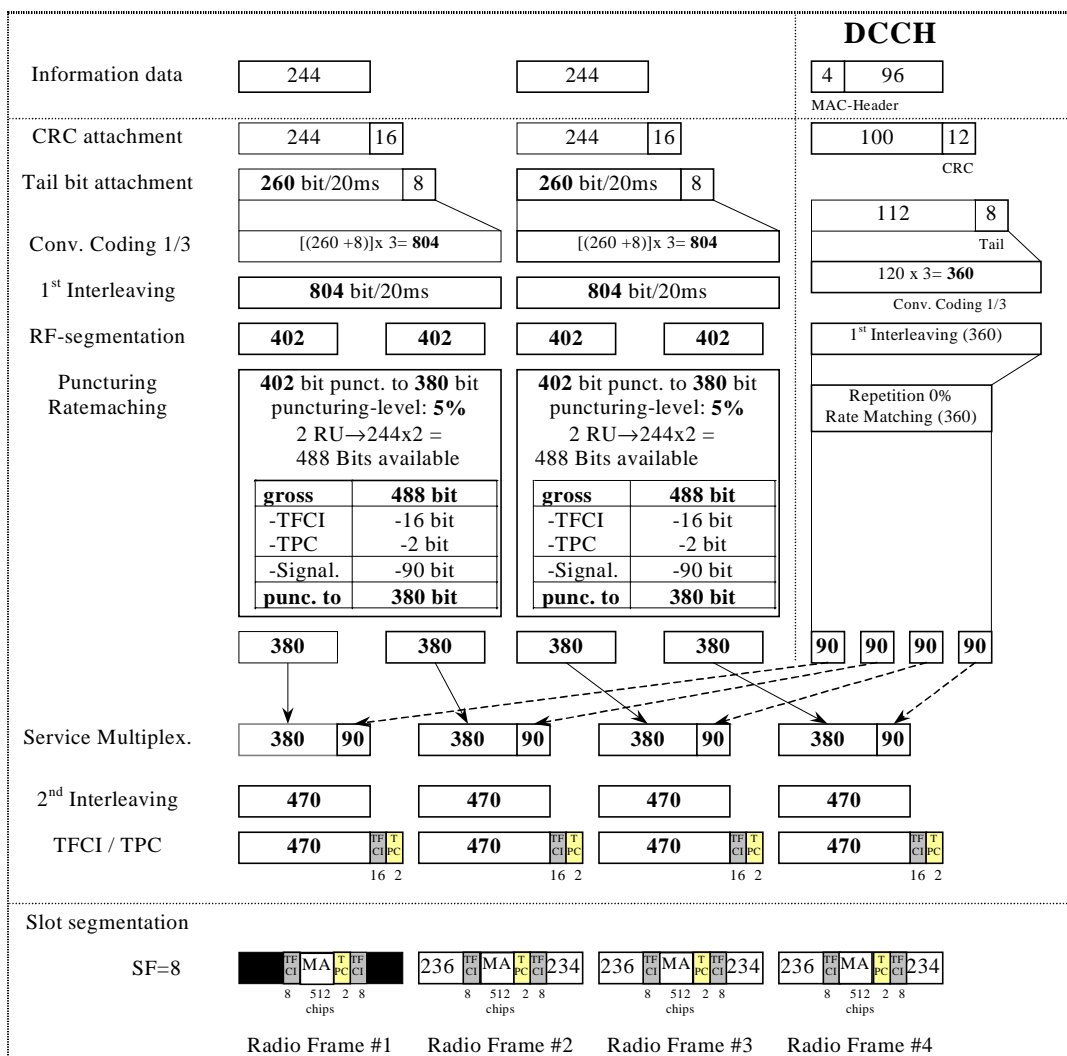

C.2.2 UL multi code reference measurement channel (12.2 kbps)

Parameter	
Information data rate	12.2 kbps
RU's allocated	2 RU
Midamble	512 chips
Interleaving	20 ms
Power control	2 Bit/user
TFCI	16 Bit/user
Inband signalling DCCH	2 kbps
Puncturing level at Code rate 1/3 : DCH / DCCH	5% / 0 %

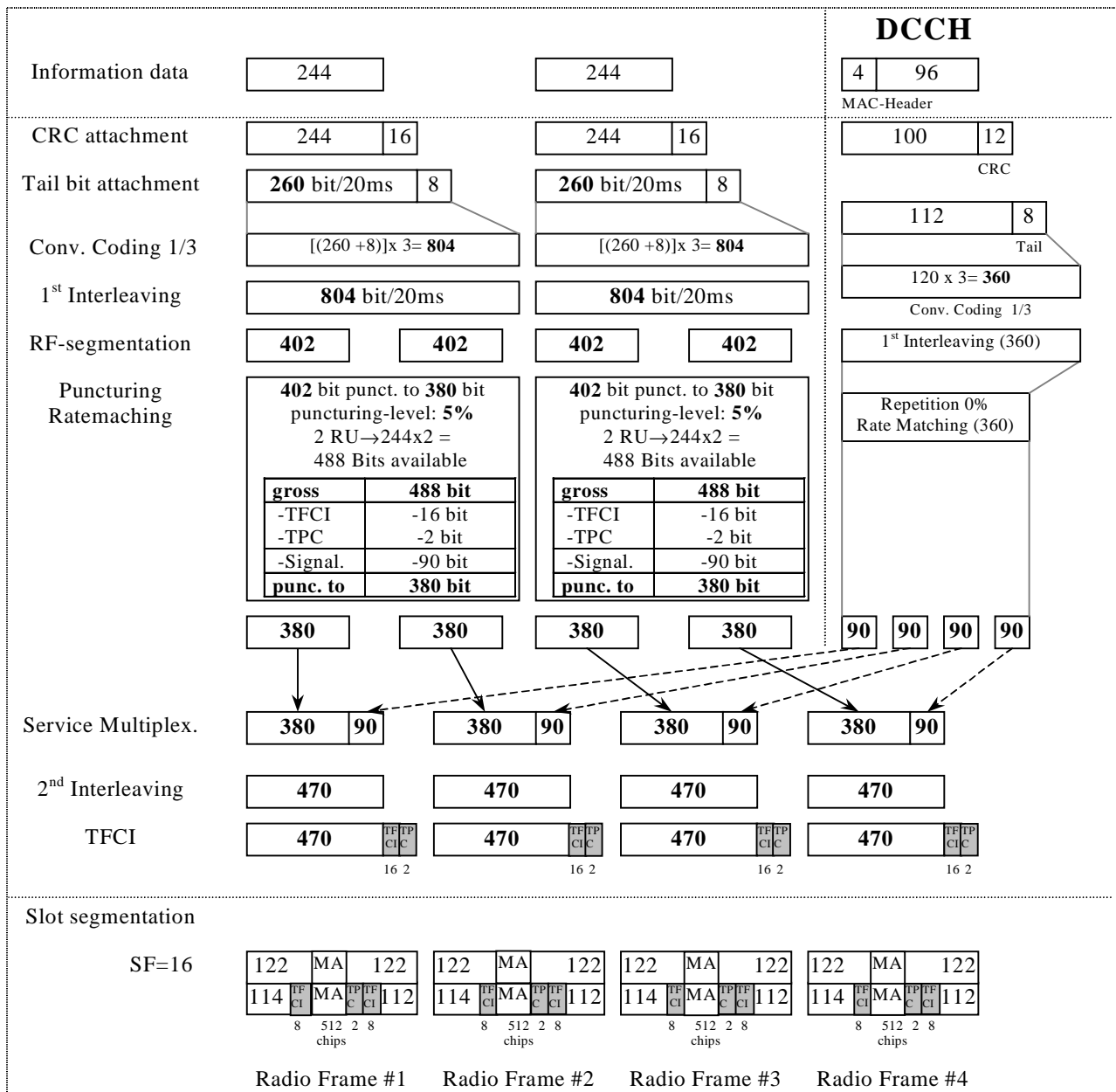

C.2.3 UL reference measurement channel (64 kbps)

Parameter	
Information data rate	64 kbps
RU's allocated	1 SF4 + 1 SF16 = 5RU
Midamble	512 chips
Interleaving	20 ms
Power control	2 Bit/user
TFCI	16 Bit/user
Inband signalling DCCH	2 kbps
Puncturing level at Code rate : 1/3 DCH / 1/2 DCCH	41.2% / 10%

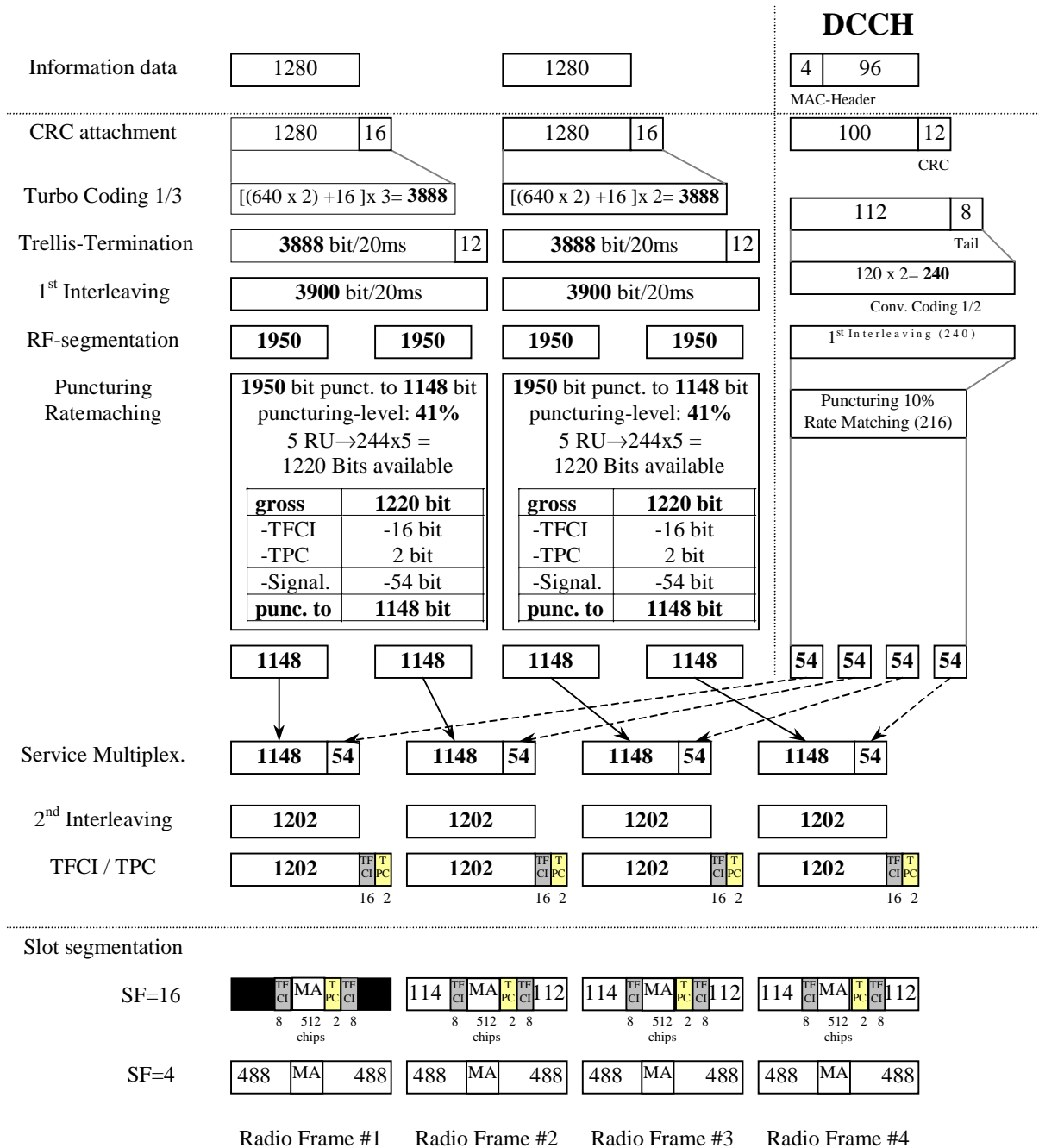

C.2.4 UL reference measurement channel (144 kbps)

Parameter	
Information data rate	144 kbps
RU's allocated	1 SF2 + 1 SF16 = 9RU
Midamble	256 chips
Interleaving	20 ms
Power control	2 Bit/user
TFCI	16 Bit/user
Inband signalling DCCH	2 kbps
Puncturing level at Code rate : 1/3 DCH / 1/2 DCCH	44.4% / 16.6%

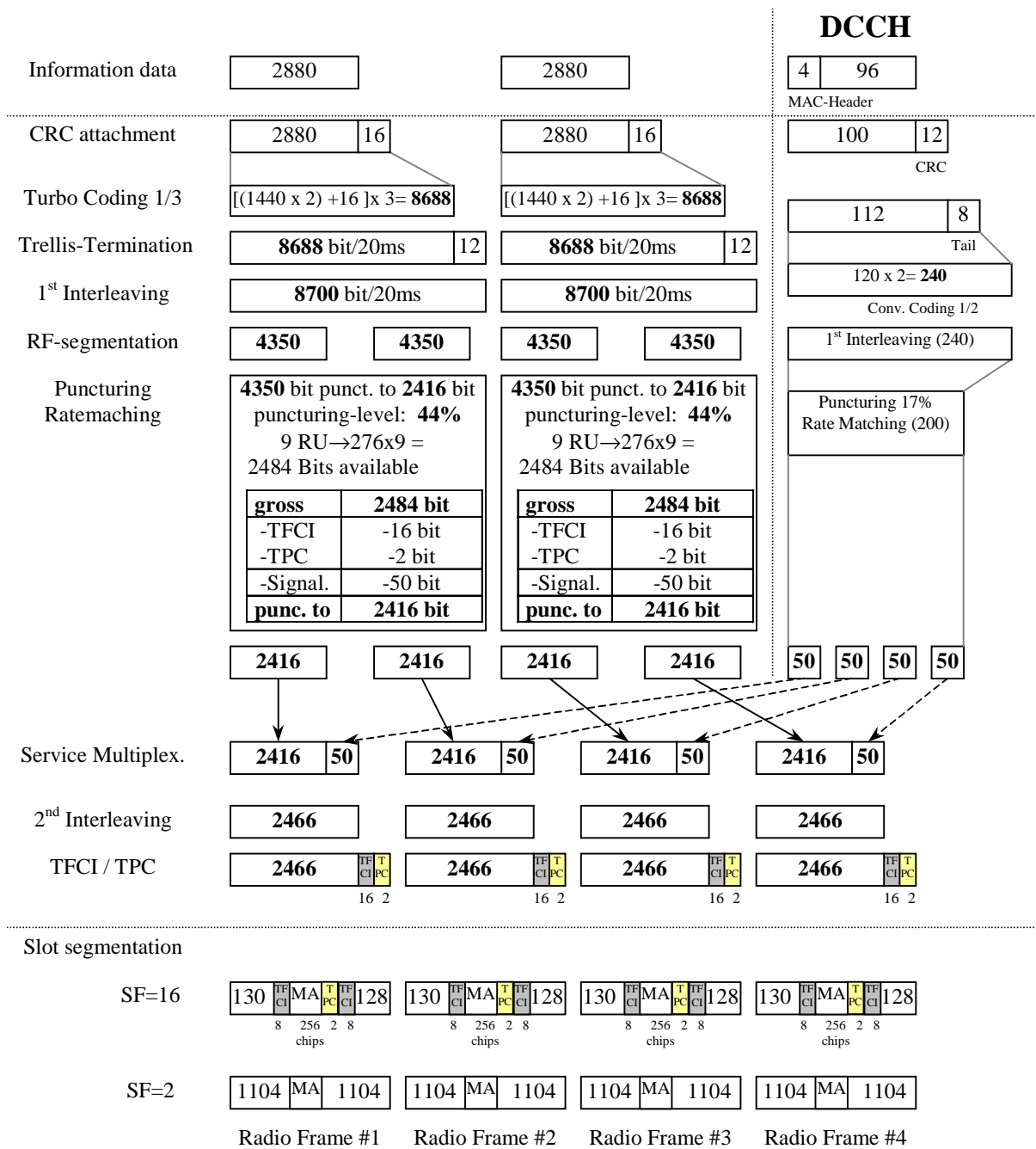

C.2.5 UL reference measurement channel (384 kbps)

Parameter	
Information data rate	384 kbps
RU's allocated	8*3TS = 24RU
Midamble	256 chips
Interleaving	20 ms
Power control	2 Bit/user
TFCI	16 Bit/user
Inband signalling DCCH	2 kbps
Puncturing level at Code rate : 1/3 DCH / 1/2 DCCH	43.4% / 15.3%

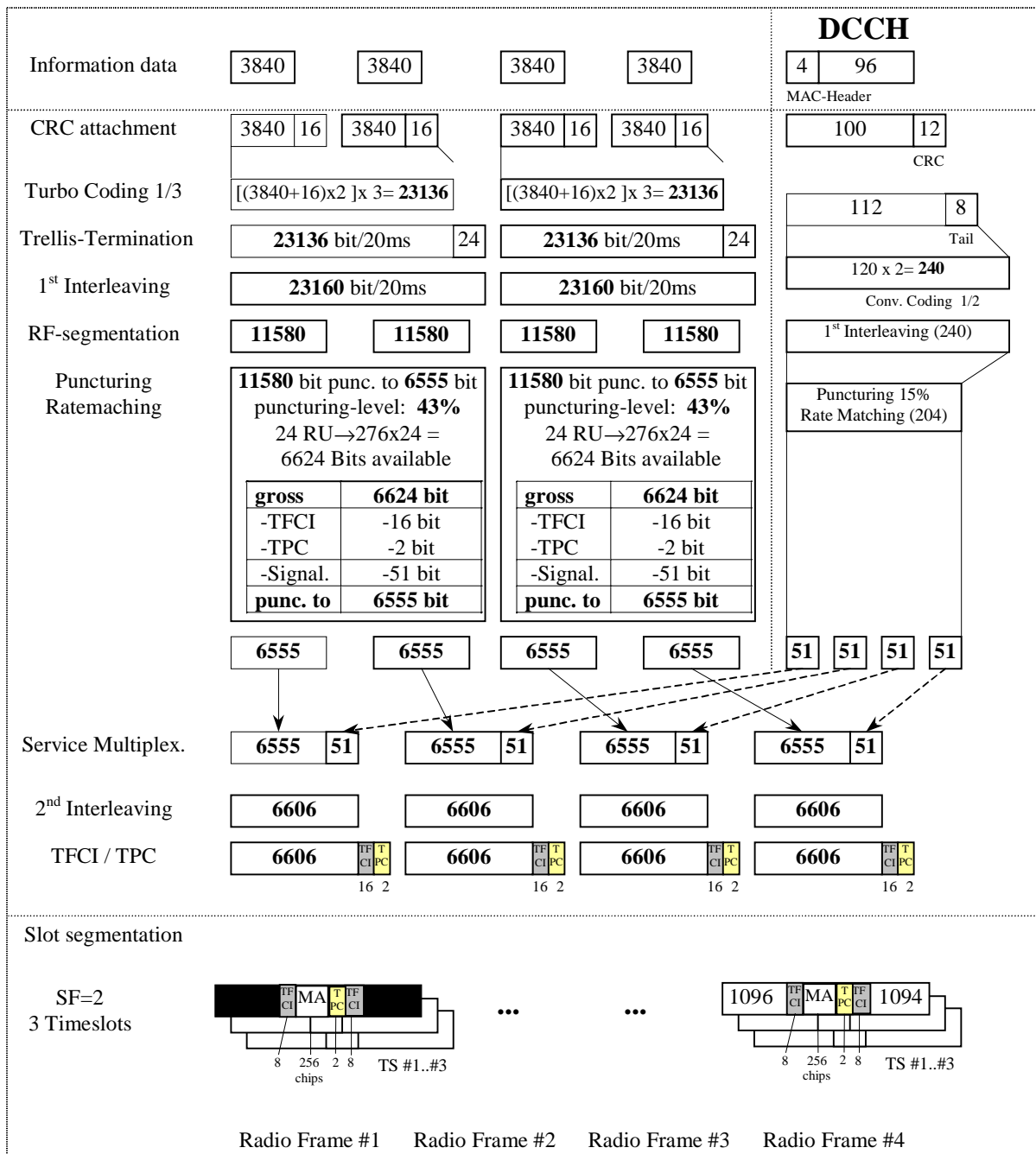

C.3 DL Reference measurement channels

C.3.3 DL reference measurement channel (12.2 kbps)

Parameter	
Information data rate	12.2 kbps
RU's allocated	2 RU
Midamble	512 chips
Interleaving	20 ms
Power control	0 Bit/user
TFCI	16 Bit/user
Inband signalling DCCH	2 kbps
Puncturing level at Code rate 1/3 : DCH / DCCH	5% / 0 %

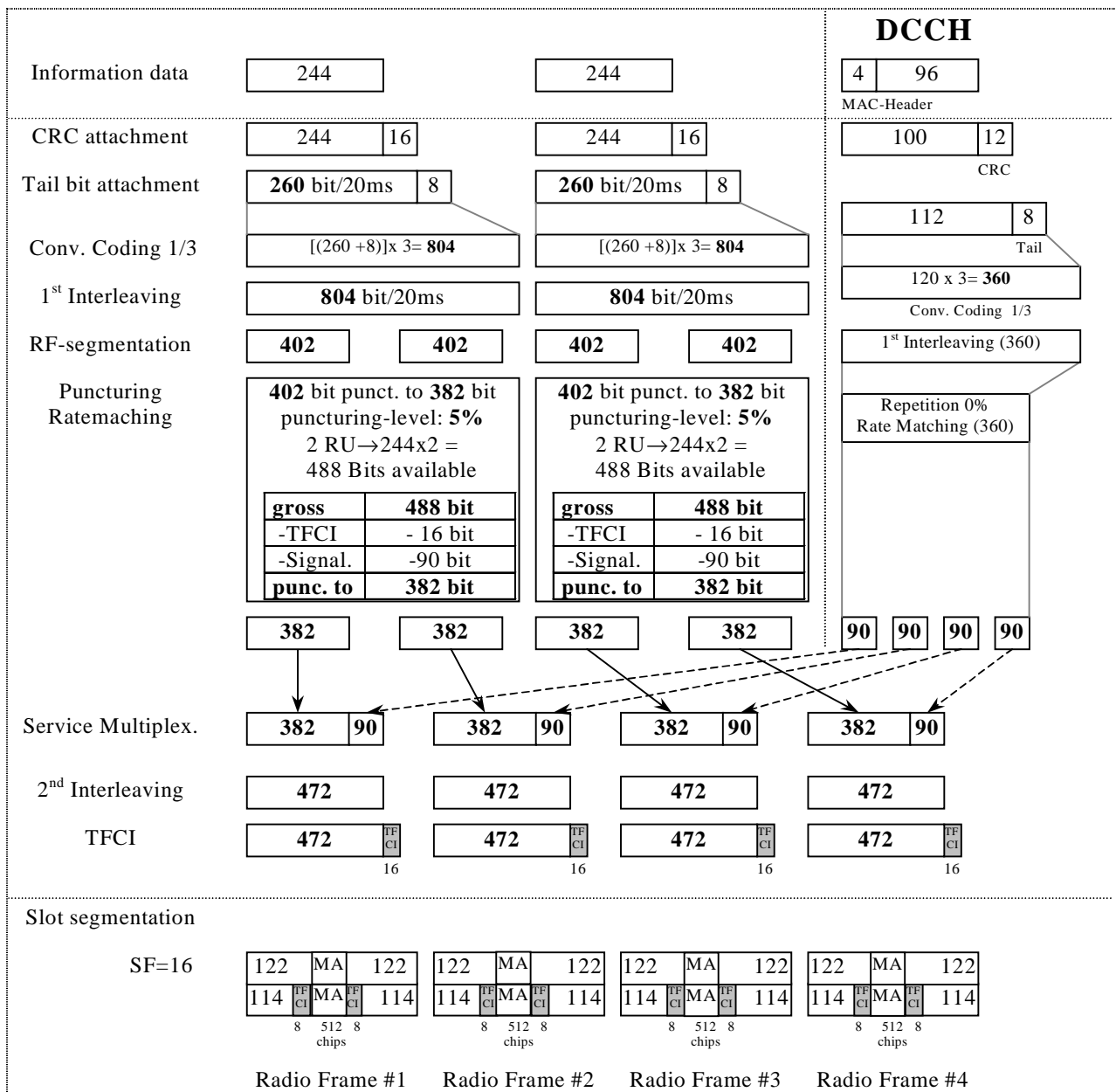

C.3.2 DL reference measurement channel (64 kbps)

Parameter	
Information data rate	64 kbps
RU's allocated	5 codes SF16 = 5RU
Midamble	512 chips
Interleaving	20 ms
Power control	0 Bit/user
TFCI	16 Bit/user
Inband signalling DCCH	2 kbps
Puncturing level at Code rate : 1/3 DCH / 1/2 DCCH	41.1% / 10%

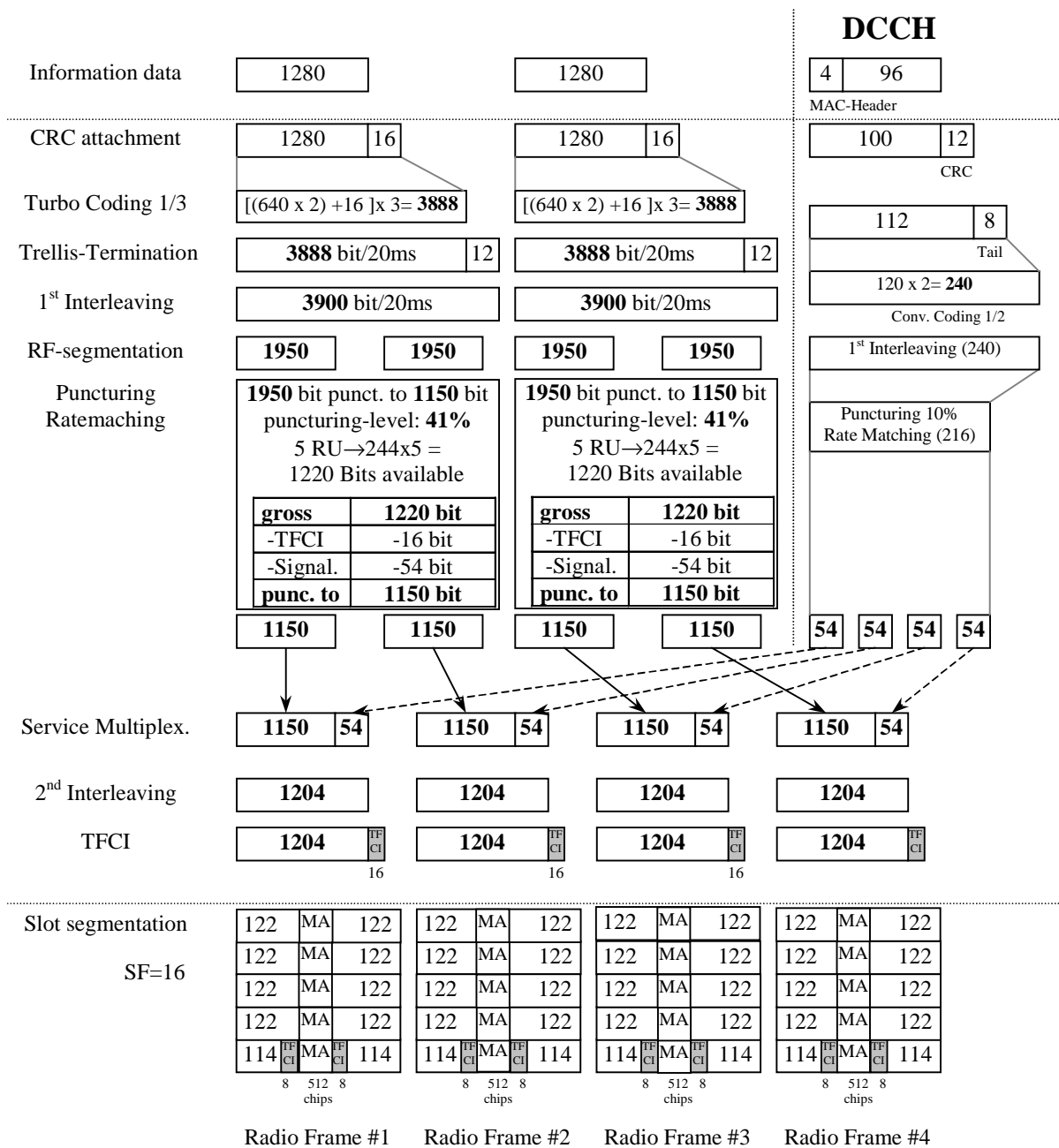

C.3.3 DL reference measurement channel (144 kbps)

Parameter	
Information data rate	144 kbps
RU's allocated	9 codes SF16 = 9RU
Midamble	256 chips
Interleaving	20 ms
Power control	0 Bit/user
TFCI	16 Bit/user
Inband signalling DCCH	2 kbps
Puncturing level at Code rate: 1/3 DCH / 1/2 DCCH	44.5% / 16.6%

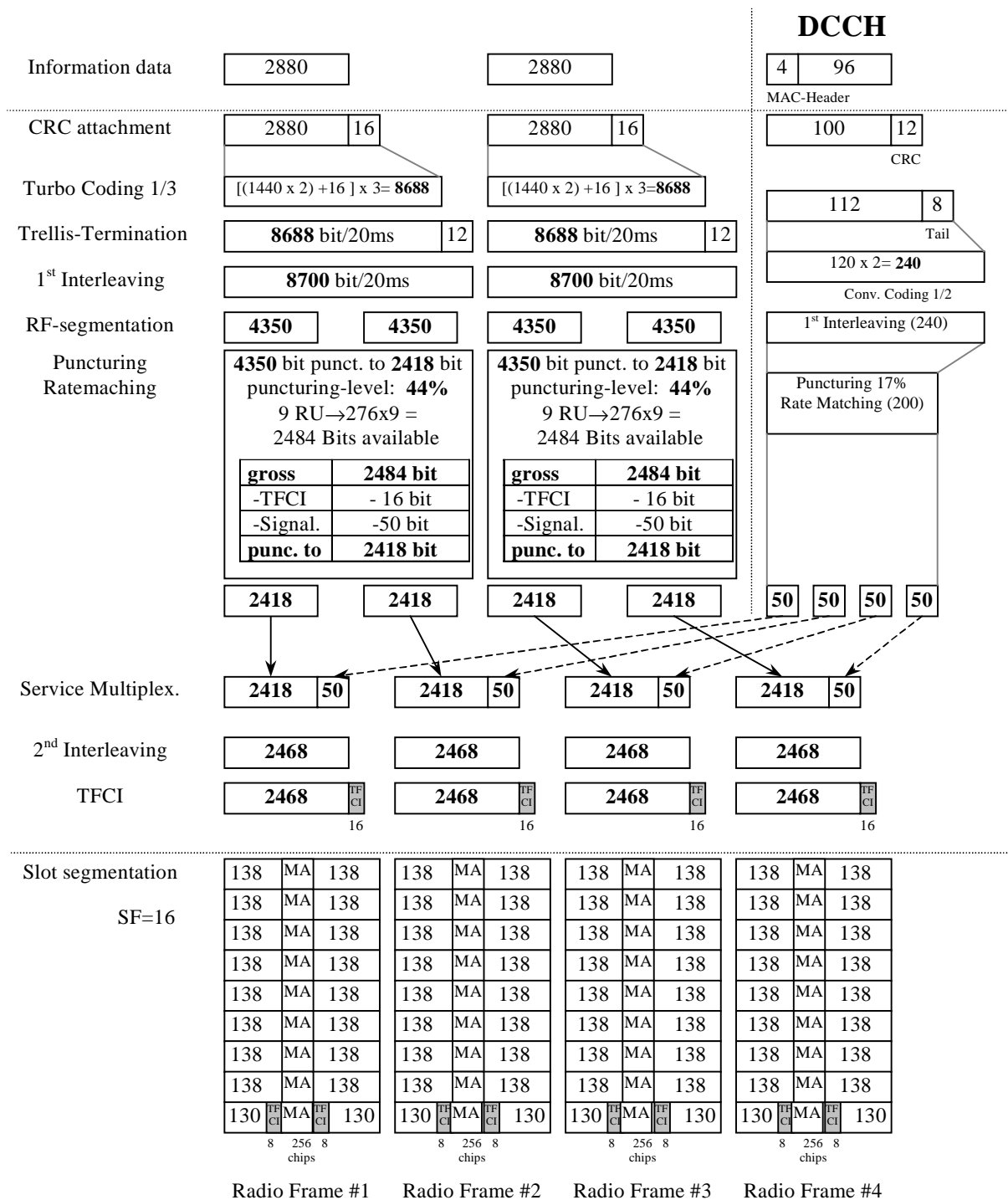

C.3.4 DL reference measurement channel (384 kbps)

Parameter	
Information data rate	384 kbps
RU's allocated	8*3TS = 24RU
Midamble	256 chips
Interleaving	20 ms
Power control	0 Bit/user
TFCI	16 Bit/user
Inband signalling DCCH	2 kbps
Puncturing level at Code rate : 1/3 DCH / 1/2 DCCH	43.4% / 15.3%

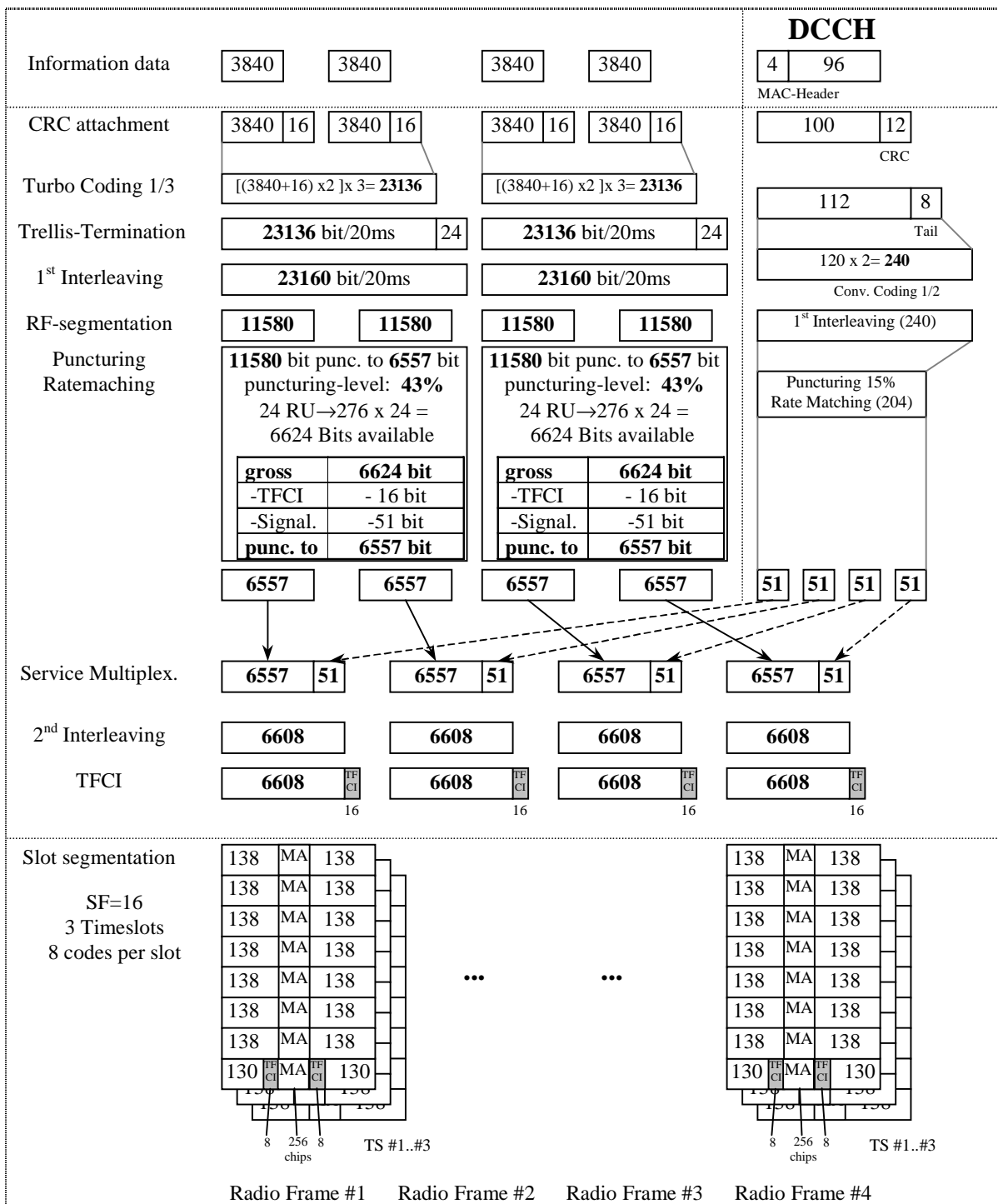

C.3.5 BCH reference measurement channel

[mapped to 1 code SF16]

Parameter	
Information data rate:	12.3 kbps
RU's allocated	1 RU
Midamble	512 chips
Interleaving	20 ms
Power control	0 bit
TFCI	0 bit
Puncturing level	10%

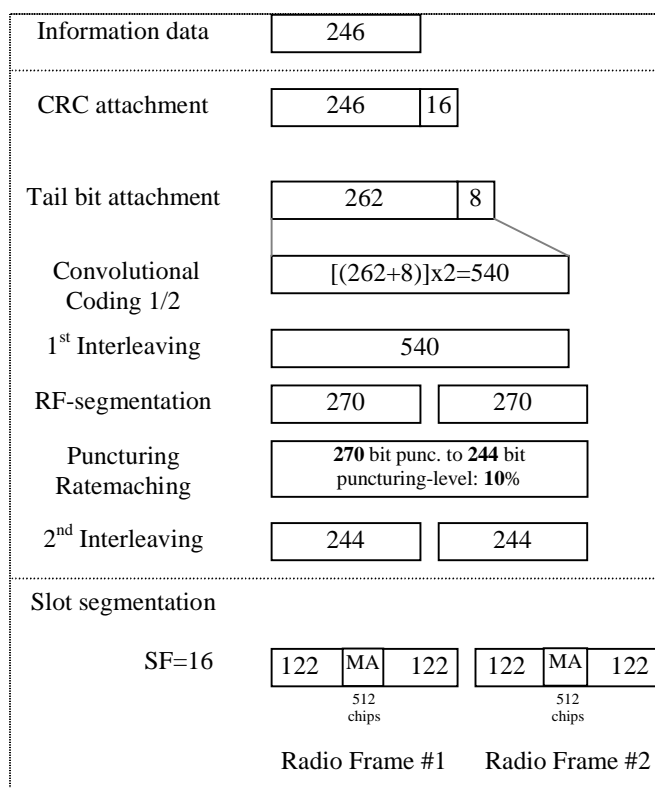

Annex D (normative): Propagation conditions

D.1 Test Environments

Table D.1 details the test services, the information data and the propagation conditions

Table D.1: Test Environments for UE Performance Specifications

Test Services	Information Data Rate	Static	Multipath Case 1	Multipath Case 2	Multipath Case 3
		Performance metric			
Paging Message			-	-	-
FACH Message			-	-	-
Circuit Switched Services	12.2 kbps	BLER <	BLER <	BLER <	BLER <
	64 kbps	BLER <	BLER <	BLER <	BLER <
	144 kbps	BLER <	BLER <	BLER <	BLER <
	384 kbps	BLER <	BLER <	BLER <	BLER <
	2048 kbps	BLER <	-	-	-
Packet Switched Data	TBD	TBD	TBD	TBD	TBD

D.2 Propagation Conditions

D.2.1 Static propagation condition

The propagation for the static performance measurement is an Additive White Gaussian Noise (AWGN) environment. No fading and multi-paths exist for this propagation model.

D.2.2 Multi-path fading propagation conditions

Table D.2 shows propagation conditions that are used for the performance measurements in multi-path fading environment. All taps have classical Doppler spectrum.

Table D.2: Propagation Conditions for Multi path Fading Environments

Case 1, speed 3km/h		Case 2, speed 3 km/h		Case 3, 120 km/h	
Relative Delay [ns]	Average Power [dB]	Relative Delay [ns]	Average Power [dB]	Relative Delay [ns]	Average Power [dB]
0	0	0	0	0	0
976	-10	976	0	260	-3
		20000	0	521	-6
				781	-9

Annex E (normative): Common RF test conditions

E.1 General

This normative annex specifies the common RF test conditions that are needed for setting a connection and channels that are needed during a connection.

E.2 Connection Set-up

Table E.2 describes the downlink Physical Channels that are required for connection set up.

Table E.2: Downlink Physical Channels required for connection set-up

Physical Channel
PSCH
PCCPCH
DPCH
PICH

E.3 During connection

The following clauses describes the uplink and downlink Physical Channels that are transmitted during a connection i.e., when measurements are done.

E.3.1 Measurement of Tx Characteristics

Table E.3.1 is applicable for measurements on the Transmitter Characteristics (Section 5) with the exception of clause 5.2 (UE maximum output power), 5.3 (Frequency Stability), 5.4.1 (Uplink Power Control). For these cases certain parameters are defined individually.

Table E.3.1.1: Common downlink test condition RF parameters

Physical Channel	Power
DPCH	-93 dBm Data content PRBS
PSCH	TBD
PCCPCH	TBD
PICH	TBD
OCNS	Nothing

Table E.3.1.2: Common TX test parameters

Parameter	Value/description
UL Reference measurement channel	12.2kbps, according to annex C.2.1
Uplink Power Control	SS level and signalling values such that UE transmits maximum power.
Data content	real life (sufficient irregular)

E.3.2 Measurement of Rx Characteristics

Table E.3.2 is applicable for measurements on the Receiver Characteristics (Section 6)

Table E.3.2: Downlink Physical Channels transmitted during a connection.

Physical Channel	Power
CPICH	TBD
PCCPCH	TBD
SCH	TBD
PICH	TBD
DPCH	TBD

E.3.3 Measurement of Performance requirements

Table E.3.3 is applicable for measurements on the Performance requirements (Section 7)

Table E.3.3: Downlink Physical Channels transmitted during a connection.

Physical Channel	Power	Note
CPICH	TBD	
PCCPCH	TBD	
SCH	TBD	
PICH	TBD	
DPCH	TBD	
OCNS	TBD	

Annex F (normative): Requirements of Test Equipment

F.1 General

[TBD]

F.2 Acceptable uncertainty of measurement equipment

[TBD]

F.3 Interpretation of measurement results

Compliance with the requirement is determined by comparing the measured value (or derived value from the measured one) with the test limit. The test limit shall be relaxed from the specified limit in the core requirement using the maximum allowed uncertainty for the test equipment as specified in subclause F.2.

The actual measurement uncertainty of the test equipment for the measurement of each parameter shall be included in the test report.

The recorded value for the test equipment uncertainty shall be, for each measurement, equal to or lower than the appropriate figure in subclause F.2 of this TS.

If the test equipment for a test is known to have a measurement uncertainty greater than that specified in subclause F.2, it is still permitted to use this apparatus provided that an adjustment is made to the measured value as follows:

The initial test limit is derived as above by relaxing the specified limit using the maximum allowed test equipment uncertainty as specified in subclause F.2. Any additional uncertainty in the test equipment over and above that specified in subclause F.2 shall be used to tighten the test limit. This procedure will ensure that test equipment not compliant with subclause F.2 does not increase the chance of passing a device under test where that device would otherwise have failed the test if test equipment compliant with subclause F.2 had been used.

Annex G (normative): Environmental conditions

G.1 General

This normative annex specifies the environmental requirements of the UE. Within these limits the requirements of this specifications shall be fulfilled.

G.2 Environmental requirements

The requirements in this clause apply to all types of UE(s)

G.2.1 Temperature

The UE shall fulfil all the requirements in the full temperature range of:

+15°C to +35°C	for normal conditions (with relative humidity of 25 % to 75 %)
-10°C to +55°C	for extreme conditions (see IEC publications 68-2-1 and 68-2-2)

Outside this temperature range the UE, if powered on, shall not make ineffective use of the radio frequency spectrum. In no case shall the UE exceed the transmitted levels as defined in TS 25.101 [1] for extreme operation.

G.2.2 Voltage

The UE shall fulfil all the requirements in the full voltage range, i.e. the voltage range between the extreme voltages.

The manufacturer shall declare the lower and higher extreme voltages and the approximate shutdown voltage. For the equipment that can be operated from one or more of the power sources listed below, the lower extreme voltage shall not be higher, and the higher extreme voltage shall not be lower than that specified below.

Power source	Lower extreme voltage	Higher extreme voltage	Normal conditions voltage
AC mains	0,9 * nominal	1,1 * nominal	nominal
Regulated lead acid battery	0,9 * nominal	1,3 * nominal	1,1 * nominal
Non regulated batteries: Leclanché / lithium Mercury/nickel & cadmium	0,85 * nominal 0,90 * nominal	Nominal Nominal	Nominal Nominal

Outside this voltage range the UE if powered on, shall not make ineffective use of the radio frequency spectrum. In no case shall the UE exceed the transmitted levels as defined in [1] TS 25.101 for extreme operation. In particular, the UE shall inhibit all RF transmissions when the power supply voltage is below the manufacturer declared shutdown voltage.

G.2.3 Vibration

The UE shall fulfil all the requirements when vibrated at the following frequency/amplitudes:

Frequency	ASD (Acceleration Spectral Density) random vibration
5 Hz to 20 Hz	0,96 m ² /s ³
20 Hz to 500 Hz	0,96 m ² /s ³ at 20 Hz, thereafter -3 dB/Octave

Outside the specified frequency range the UE, if powered on, shall not make ineffective use of the radio frequency spectrum. In no case shall the UE exceed the transmitted levels as defined in TS 25.101 [1] for extreme operation.

Annex H (normative): Terminal Baseline and Service Implementation Capabilities (TDD)

H.1 Baseline Implementation Capabilities:

Table H.1: Baseline implementation capabilities

Capability TDD	Section	UE*	Comments
Chip rate 3.84 Mcps		M	
Frequency bands: (uplink and downlink)			
1900-1920 MHz		M	
2010-2025 MHz		M	
1850-1910 MHz		M	
1930-1990 MHz		M	
1910-1930 MHz		M	
Other spectrum		O	As Declared
Carrier raster 200 kHz		M	
UE maximum output power	4.2.2	M	At least one power class

(* M = mandatory, O = optional)

- The special conformance testing functions and the logical test interface as specified in TS 34.109 [3]. This issue is currently under investigation.
- Uplink reference measurement channel 12.2 kbps (FDD), TS 25.102 [1] subclause A.2.1.
- Downlink reference measurement channel 12.2 kbps (FDD), TS 25.102 [1] subclause A.2.2.

H.2 Service Implementation Capabilities:

- Downlink reference measurement channel 64 kbps (TDD), TS 25.102 subclause A.2.3.
- Downlink reference measurement channel 144 kbps (TDD), TS 25.102 subclause A.2.4.
- Down-link reference measurement channel 384 kbps (TDD), TS 25.102 subclause A.2.5.
- BCH Reference Measurement Channel.

Annex I (informative): Change history

V0.0.0	1999-02-xx	Initial document. Except for the scope, all clauses are just blank.
V0.1.0	1999-04-13	Two reference documents are added. Other contents are not changed.
V0.0.2	1999-05-14	The document numbering was changed from TS XX.XX to iTS-T1.004. Other contents are not changed.
V0.0.3	1999-07-16	3GPP template and number
V0.0.4	1999-07-29	Version updated. Contents are not changed
V0.1.0	1999-09-09	Clause 4 filled with content according to TSG-T SWG RF #6 and with headers according to TS 25.102 V 1.3.0. Clause 5,6 and 7 filled with headers Annexes filled with headers or content
V0.2.0	1999-10-20	Subclause 4.4 filled according to TSG-T-SWG RF#6 Clauses >4.4 to 6 filled with structure and partly with content derived from TS 25.102 V2.0.0 (1999-09) Annex D (propagation..) and annex C(measurement channels) copied from TS 25.102 V2.0.0 (1999-09)
V0.2.1	1999-11-25	Updating of the format
V0.3.0	199-12-01	Clause 4 updated according to T1RF SWG #8 Meeting Results of RAN4 Meeting #8 on 4.4.1. Uplink Power Control included
V 0.4.0.	1999-12-07	Results of T1RF SWG #9 Meeting (Dec 6 and 7 only) included
V 1.0.0	1999-12-08	Content of V 0.4.0 raised to V 1.0.0 by T1#5 without change of content
V 1.1.0	2000-01-14	Changes in TS 25.102 V3.1.0 integrated Harmonisation with TS 34.121
V 1.2.0.	2000-02-16	Results of T1RF #10 included (Clause 7), RRM: Clause 8 with subclause structure created, minor editorial amendments
V1.2.1	2000-03-30	Editorial corrections
V 1.3.1	2000-04-05	Results of T1RF #11 included RAN4#11 agreed CRs included Editorial changes
V 1.4.0	2000-06-2	Results of T1RF #12 included Results of RAN4 #12 included
V 1.5.0	2000-06-6	Results of T1RF#13 included
V 2.0.0	2000-06-15	Presented to TSG-T as version 2.0.0

Editor for:

Terminal Conformance Specifications; Radio Transmission and Reception (TDD)

Thomas Maucksch

Rohde & Schwarz

Tel: +49 89 4129 2124

Fax: +49 89 4129 3443

This document is written in Microsoft® Word 97.