

**3GPP TSG-T meeting #4
Miami, Florida / USA, 17-18 June 1999**

TSG#4(99)113

**Title: TS 34.121 v1.0.0 “Technical Conformance Specification, Radio
Transmission and Reception (FDD)”**

Source: T WG1

Document for information

3G TS 34.121 V1.0.0 (1999-06)

**3rd Generation Partnership Project (3GPP)
Technical Specification Group (TSG) Terminal
Terminal Conformance Specification;
Radio transmission and reception (FDD)**



Reference

<Workitem>

Keywords

<keyword[, keyword]>

3GPP

Postal address

Office address

Internet

secretariat@3gpp.org

Individual copies of this deliverable

can be downloaded from

<http://www.3gpp.org>

Copyright Notification

Reproduction is only permitted for the purpose of standardization work undertaken within xxxx.
The copyright and the foregoing restrictions extend to reproduction in all media.

xxxxxx...xxx

All rights reserved.

Contents

Intellectual Property Rights	8
Foreword.....	8
Introduction.....	8
1 Scope	9
2 References.....	9
3 Terms and abbreviations.....	9
4 Transmitter Characteristics	14
4.1 General.....	14
4.2 Maximum Output Power.....	15
4.2.1 Definition and applicability.....	15
4.2.2 Conformance requirements	15
4.2.3 Test purpose	15
4.2.4 Method of test.....	15
4.2.4.1 Initial conditions.....	15
4.2.4.2 Procedure	16
4.2.5 Test Requirements	16
4.3 Frequency Stability	17
4.3.1 Definition and applicability.....	17
4.3.2 Conformance requirements	17
4.3.3 Test purpose	17
4.3.4 Method of test.....	17
4.3.4.1 Initial conditions.....	17
4.3.4.2 Procedure	18
4.3.5 Test Requirements	18
4.4 Output Power Dynamics in the Uplink.....	19
4.4.1 Open Loop Power Control in the Uplink	19
4.4.1.1 Definition and applicability.....	19
4.4.1.2 Conformance requirements	19
4.4.1.3 Test purpose	19
4.4.1.4 Method of test.....	19
4.4.1.4.1 Initial conditions.....	19
4.4.1.4.2 Procedure	20
4.4.1.5 Test Requirements	20
4.4.2 Closed Loop Power Control in the Uplink	21
4.4.2.1 Definition and applicability.....	21
4.4.2.2 Conformance requirements	21
4.4.2.3 Test purpose	21
4.4.2.4 Method of test.....	21
4.4.2.4.1 Initial conditions.....	21
4.4.2.4.2 Procedure	22
4.4.2.5 Test Requirements	22
4.4.3 Minimum Output Power	23
4.4.3.1 Definition and applicability.....	23
4.4.3.2 Conformance requirements	23
4.4.3.3 Test purpose	23
4.4.3.4 Method of test.....	23
4.4.3.4.1 Initial conditions.....	23

4.4.3.4.2	Procedure	23
4.4.3.5	Test Requirements	24
4.5	Transmit OFF Power	25
4.5.1	Definition and applicability.....	25
4.5.2	Conformance requirements	25
4.5.3	Test purpose	25
4.5.4	Method of test.....	25
4.5.4.1	Initial conditions.....	25
4.5.4.2	Procedure	25
4.5.5	Test Requirements	26
4.6	DTX	28
4.6.1	Definition and applicability.....	28
4.6.2	Conformance requirements	28
4.6.3	Test purpose	28
4.6.4	Method of test.....	28
4.6.4.1	Initial conditions.....	28
4.6.4.2	Procedure	29
4.6.5	Test Requirements	29
4.7	Occupied Bandwidth.....	30
4.7.1	Definition and applicability.....	30
4.7.2	Conformance requirements	30
4.7.3	Test purpose	30
4.7.4	Method of test.....	30
4.7.4.1	Initial conditions.....	30
4.7.4.2	Procedure	30
4.7.5	Test Requirements	30
4.8	Adjacent Channel Leakage Power Ratio (ACLR).....	31
4.8.1	Leakage Power due to Modulation	31
4.8.1.1	Definition and applicability.....	31
4.8.1.2	Conformance requirements	31
4.8.1.3	Test purpose	31
4.8.1.4	Method of test.....	31
4.8.1.4.1	Initial conditions.....	31
4.8.1.4.2	Procedure	32
4.8.1.5	Test Requirements	32
4.8.2	Leakage Power due to Switching.....	33
4.8.2.1	Definition and applicability.....	33
4.8.2.2	Conformance requirements	33
4.8.2.3	Test purpose	33
4.8.2.4	Method of test.....	33
4.8.2.4.1	Initial conditions.....	33
4.8.2.4.2	Procedure	34
4.8.2.5	Test Requirements	34
4.9	Spurious Emissions.....	35
4.9.1	Definition and applicability.....	35
4.9.2	Conformance requirements	35
4.9.3	Test purpose	35
4.9.4	Method of test.....	35
4.9.4.1	Initial conditions.....	35
4.9.4.2	Procedure	36
4.9.5	Test Requirements	36
4.10	Transmit Intermodulation	37
4.10.1	Definition and applicability.....	37
4.10.2	Conformance requirements	37
4.10.3	Test purpose	37

4.10.4	Method of test.....	37
4.10.4.1	Initial conditions.....	37
4.10.4.2	Procedure	38
4.10.5	Test Requirements	38
4.11	Modulation Accuracy.....	39
4.11.1	Definition and applicability.....	39
4.11.2	Conformance requirements	39
4.11.3	Test purpose	39
4.11.4	Method of test.....	39
4.11.4.1	Initial conditions.....	39
4.11.4.2	Procedure	40
4.11.5	Test Requirements	40
5	Receiver Characteristics	42
5.1	General.....	42
5.2	Reference Sensitivity Level.....	43
5.2.1	Definition and applicability.....	43
5.2.2	Conformance requirements	43
5.2.3	Test purpose	43
5.2.4	Method of test.....	43
5.2.4.1	Initial conditions.....	43
5.2.4.2	Procedure	43
5.2.5	Test Requirements	44
5.3	Maximum Input Level	45
5.3.1	Definition and applicability.....	45
5.3.2	Conformance requirements	45
5.3.3	Test purpose	45
5.3.4	Method of test.....	45
5.3.4.1	Initial conditions.....	45
5.3.4.2	Procedure	46
5.3.5	Test Requirements	46
5.4	Adjacent Channel Selectivity (ACS)	47
5.4.1	Definition and applicability.....	47
5.4.2	Conformance requirements	47
5.4.3	Test purpose	47
5.4.4	Method of test.....	47
5.4.4.1	Initial conditions.....	47
5.4.4.2	Procedure	48
5.4.5	Test Requirements	48
5.5	Blocking Characteristics	49
5.5.1	Definition and applicability.....	49
5.5.2	Conformance requirements	49
5.5.3	Test purpose	49
5.5.4	Method of test.....	49
5.5.4.1	Initial conditions.....	49
5.5.4.2	Procedure	50
5.5.5	Test Requirements	50
5.6	Spurious Response	51
5.6.1	Definition and applicability.....	51
5.6.2	Conformance requirements	51
5.6.3	The reference for this requirement is 25.101 §7.7.Test purpose.....	51
5.6.4	Method of test.....	51
5.6.4.1	Initial conditions.....	51
5.6.4.2	Procedure	51
5.6.5	Test Requirements	52

5.7	Intermodulation Characteristics	53
5.7.1	Definition and applicability.....	53
5.7.2	Conformance requirements	53
5.7.3	Test purpose	53
5.7.4	Method of test.....	53
5.7.4.1	Initial conditions.....	53
5.7.4.2	Procedure	54
5.7.5	Test Requirements	54
5.8	Spurious Emissions.....	55
5.8.1	Definition and applicability.....	55
5.8.2	Conformance requirements	55
5.8.3	Test purpose	55
5.8.4	Method of test.....	55
5.8.4.1	Initial conditions.....	55
5.8.4.2	Procedure	55
5.8.5	Test Requirements	55
5.9	RSCP Detection Range and Accuracy	56
5.9.1	Definition and applicability.....	56
5.9.2	Conformance requirements	56
5.9.3	Test purpose	56
5.9.4	Method of test.....	56
5.9.4.1	Initial conditions.....	56
5.9.4.2	Procedure	56
5.9.5	Test Requirements	57
5.10	SIR Measurement Range and Accuracy.....	58
5.10.1	Definition and applicability.....	58
5.10.2	Conformance requirements	58
5.10.3	Test purpose	58
5.10.4	Method of test.....	58
5.10.4.1	Initial conditions.....	58
5.10.4.2	Procedure	59
5.10.5	Test Requirements	59
6	<i>Performance requirements</i>	60
6.1	<i>General</i>	60
6.1.1	<i>Test Environments</i>	60
6.1.2	<i>Channel Models</i>	60
6.1.3	<i>CDMA Equations</i>	61
6.1.3.1	<i>BS or SS Transmission Power</i>	61
6.1.3.2	<i>Received Signal Strength for MS Not in Handoff (Static Channel)</i>	61
6.1.3.3	<i>Received Signal Strength for MS Not in Handoff (Non-Static Channel)</i>	62
6.1.3.4	<i>Received Signal Strength for MS in Two-Way Handover</i>	63
6.1.3.5	<i>Measurement Configurations</i>	64
6.2	<i>Demodulation in Static Channel</i>	66
6.2.1	<i>Demodulation of Paging Channel</i>	66
6.2.1.1	<i>Definition and applicability</i>	66
6.2.1.2	<i>Test Conditions and Measurement Method</i>	66
6.2.1.3	<i>Test Requirements</i>	66
6.2.2	<i>Demodulation of Forward Access Channel</i>	66
6.2.2.1	<i>Definition and applicability</i>	67
6.2.2.2	<i>Test Conditions and Measurement Method</i>	67
6.2.2.3	<i>Test Requirements</i>	67
6.2.3	<i>Demodulation of Dedicated Traffic Channel</i>	67
6.2.3.1	<i>Definition and applicability</i>	67
6.2.3.2	<i>Test Conditions and Measurement Method</i>	67

6.2.3.3	<i>Test Requirements</i>	68
6.3	<i>Demodulation of Dedicated Traffic Channel in Multipath Fading Channel</i>	69
6.3.1	<i>Single Link Performance</i>	69
6.3.1.1	<i>Definition and applicability</i>	69
6.3.1.2	<i>Test Conditions and Measurement Method</i>	69
6.3.1.3	<i>Test Requirements</i>	71
6.3.2	<i>Inter-Cell Soft Handover Performance</i>	71
6.3.2.1	<i>Definition and applicability</i>	71
6.3.2.2	<i>Test Conditions and Measurement Method</i>	71
6.3.2.3	<i>Test Requirements</i>	72
6.4	<i>Synchronization Performance</i>	73
6.4.1	<i>Search of other Cells</i>	73
6.4.1.1	<i>Definition and applicability</i>	73
6.4.1.2	<i>Test Conditions and Measurement Method</i>	73
6.4.1.3	<i>Test Requirements</i>	73
6.4.2	<i>Inter-Frequency Handover</i>	73
6.4.2.1	<i>Definition and applicability</i>	73
6.4.2.2	<i>Test Conditions and Measurement Method</i>	74
6.4.2.3	<i>Test Requirements</i>	74
6.5	<i>Timing requirements</i>	75
6.5.1	<i>Synchronization</i>	75
6.5.1.1	<i>Definition and applicability</i>	75
6.5.1.2	<i>Test Conditions and Measurement Method</i>	75
6.5.1.3	<i>Test Requirements</i>	75
6.5.2	<i>Channel Timing Dependencies</i>	75
6.5.2.1	<i>Definition and applicability</i>	75
6.5.2.2	<i>Test Conditions and Measurement Method</i>	75
6.5.2.3	<i>Test Requirements</i>	75
6.5.3	<i>Reception Timing</i>	75
6.5.3.1	<i>Definition and applicability</i>	75
6.5.3.2	<i>Test Conditions and Measurement Method</i>	76
6.5.3.3	<i>Test Requirements</i>	76
7	<i>Requirement of Test Equipment</i>	77
Annex.1	<i>Connection Diagrams</i>	78
Bibliography	81
History	82

Intellectual Property Rights

IPRs essential or potentially essential to the present document may have been declared to ETSI. The information pertaining to these essential IPRs, if any, is publicly available for **ETSI members and non-members**, and can be found in ETR 314: "*Intellectual Property Rights (IPRs); Essential, or potentially Essential, IPRs notified to ETSI in respect of ETSI standards*", which is available **free of charge** from the ETSI Secretariat. Latest updates are available on the ETSI Web server (<http://www.etsi.fr/ipr>).

Pursuant to the ETSI Interim IPR Policy, no investigation, including IRP searches, has been carried out by ETSI. No guarantee can be given as to the existence of other IPRs not referenced in ETR 314 (or the updates on <http://www.etsi.fr/ipr>) which are, or may be, or may become, essential to the present document.

Foreword

This Technical Specification has been produced by the 3rd Generation Partnership Project, Technical Specification Group Terminal, Working Group 1 / RF sub-working-group (3GPP TSG-T WG1/RF).

The contents of this TS may be subject to continuing work within the 3GPP and may change following formal TSG approval. Should the TSG modify the contents of this TS, it will be re-released with an identifying change of release date and an increase in version number as follows:

Version m.x.y

where:

m indicates [major version number]

x the second digit is incremented for all changes of substance, i.e. technical enhancements, corrections, updates, etc.

y the third digit is incremented when editorial only changes have been incorporated into the specification.

Introduction

[TBD]

1 Scope

This present document specifies the measurement procedures for the conformance test of the mobile station (MS) that contain transmitting characteristics, receiving characteristics and *performance requirements* in FDD mode.

2 References

The following documents contain provisions which, through reference in this text, constitute provisions of the present document.

- References are either specific (identified by date of publication, edition number, version number, etc.) or non-specific.
- For a specific reference, subsequent revisions do not apply.
- For a non-specific reference, subsequent revisions do apply.
- A non-specific reference to an ETS shall also be taken to refer to later versions published as an EN with the same number.

[1] 3GPP 25.101v1.2.0 "UE Radio transmission and reception (FDD)"

[2] 3GPP S25.103v0.1.0 "RF Parameters in Support of Radio Resource Management (RRM)"

[3] 3GPP ITS-T1.001v??.? "Logical Test Interface (FDD) Special conformance testing functions"

3 Terms and abbreviations

For the purpose of the present document, the following terms and abbreviations apply.

AFC	Automatic Frequency Control
ACLR	Adjacent Channel Leakage power Ratio
ACS	Adjacent Channel Selectivity
ATT	Attenuator
AWGN	Additive White Gaussian Noise
BER	Bit Error Rate
BS	Base Station
CDMA	Code-Division Multiple Access
Chip Rate	Chip rate of W-CDMA system, equals to 4.096 M chips per second.
CRC	Cyclic Redundancy Code

CW	Continuous Wave (unmodulated signal)
Data $_ E_c$	Average energy per PN chip for the DATA fields in the DPCH.
Data $\frac{E_c}{I_o}$	The ratio of the received energy per PN chip for the DATA fields of the DPCH to the total received power spectral density at the MS antenna connector.
$\frac{\text{Data } _ E_c}{I_{or}}$	The ratio of the average transmit energy per PN chip for the DATA fields of the DPCH to the total transmit power spectral density.
DCH	Dedicated Channel, which is mapped into Dedicated Physical Channel. DCH contains the data.
DL	DownLink (= forward link)
DPCH	Dedicated Physical Channel
DPCH $_ E_c$	Average energy per PN chip for DPCH.
$\frac{\text{DPCH } _ E_c}{I_{or}}$	The ratio of the received energy per PN chip of the DPCH to the total received power spectral density at the MS antenna connector.
DTX	Discontinuous Transmission
E_b	Average energy per information bit for the PCCPCH, DPCH SCCPCH, PCH, and for FACH at the MS antenna connector.
$\frac{E_b}{N_t}$	The ratio of combined received energy per information bit to the effective noise power spectral density for the PCCPCH Channel, DPCH SCCPCH, PCH, and for the FACH at the MS antenna connector. Following items are calculated as overhead: pilot, TPC, TFICI, CRC, tail, repetition, convolution coding and Turbo coding.
E_c	Average energy per PN chip.
$\frac{E_c}{I_{or}}$	The ratio of the average transmit energy per PN chip for different fields or physical channels to the total transmit power spectral density.
EIRP	Effective Isotropic Radiated Power
EVM	Error Vector Magnitude
FACH	Forward Access Channel
FDD	Frequency Division Duplexing
FER	Frame Error Rate
F_{uw}	<i>Frequency of unwanted signal</i>
HYB	Hybrid

Information Data Rate	Rate of the user information, which must be transmitted over the Air Interface. For example, output rate of the voice codec.
I_o	The total received power spectral density, including signal and interference, as measured at the MS antenna connector.
I_{oac}	The power spectral density of the adjacent frequency channel as measured at the MS antenna connector.
I_{oc}	The power spectral density of a band limited white noise source (simulating interference from other cells) as measured at the MS antenna connector.
I_{or}	The total transmit power spectral density of the Forward link at the base station or SS antenna connector.
\hat{I}_{or}	The received power spectral density of the Forward link as measured at the MS antenna connector.
MER	Message Error Rate
MS	Mobile Station
N_t	The effective noise power spectral density at the MS antenna connector.
OCNS	Orthogonal Channel Noise Simulator, a mechanism used to simulate the users or control signals on the other orthogonal channels of a Forward link.
OCNS _ E_c	Average energy per PN chip for the OCNS.
$\frac{OCNS_E_c}{I_{or}}$	The ratio of the average transmit energy per PN chip for the OCNS to the total transmit power spectral density.
PCCPCH	Primary Common Control Physical Channel
$PCCPCH \frac{E_c}{I_o}$	The ratio of the received PCCPCH energy per chip to the total received power spectral density at the MS antenna connector.
$\frac{PCCPCH_E_c}{I_{or}}$	The ratio of the average transmit energy per PN chip for the PCCPCH to the total transmit power spectral density.
Pilot _ E_c	Average energy per PN chip for the Pilot field in the DPCH.
$Pilot \frac{E_c}{I_o}$	The ratio of the received energy per PN chip for the Pilot field of the DPCH to the total received power spectral density at the MS antenna connector.
$\frac{Pilot_E_c}{I_{or}}$	The ratio of the average transmit energy per PN chip for the Pilot field of the DPCH to the total transmit power spectral density.
PN	Pseudo-random Noise

RACH	Random Access Channel
RI_E_c	Average energy per PN chip for the Rate Information field in the DPCH.
$RI \frac{E_c}{I_o}$	The ratio of the received energy per PN chip for the Rate Information field of the DPCH to the total received power spectral density at the MS antenna connector.
$\frac{RI_E_c}{I_{or}}$	The ratio of the average transmit energy per PN chip for the Rate Information field of the DPCH to the total transmit power spectral density.
RRM	Radio Resource Management
RSCP	Received Signal Code Power
RX	Receiver
SCCPCH	Secondary Common Control Physical Channel
SCCPCH_ E_c	Average energy per PN chip for SCCPCH
SIR	Signal to Interference Ratio
SS	System Simulator
TFCI	Transport Format Combination Identifier
TPC	Transmit Power Control
TPC_E_c	Average energy per PN chip for the Transmission Power Control field in the DPCH.
$TPC \frac{E_c}{I_o}$	The ratio of the received energy per PN chip for the Transmission Power Control field of the DPCH to the total received power spectral density at the MS antenna connector.
$\frac{TPC_E_c}{I_{or}}$	The ratio of the average transmit energy per PN chip for the Transmission Power Control field of the DPCH to the total transmit power spectral density.
TX	Transmitter
UARFCN	UTRA Absolute Radio Frequency Channel Number
UL	UpLink (= reverse link)
UMTS	Universal Mobile Telecommunications System
UTRA	UMTS Terrestrial Radio Access
UTRAN	UMTS Terrestrial Radio Access Network

<Editor's Note> Radio Frequency Bands specification will be inserted here.

4 Transmitter Characteristics

4.1 General

Transmitting performance test of the MS is implemented during communicating with the SS via air interface. The procedure is used normal call protocol until the MS is communicating on traffic channel basically. On the traffic channel, the MS provides special function for testing that is called Logical Test Interface and the MS is tested using this function. (Refer to iTS-T1.001 Logical Test Interface)

Transmitting or receiving bit/symbol rate for test channel is shown in Table 4.1.

Table 4.1 Bit / Symbol rate for Test Channel

Type of User Information	User bit rate	Forward DPCH symbol rate	Reverse DPCH bit rate	Remarks
Speech	12.2kbps	32ksps	64kbps	Standard Test
Circuit Switched Data	TBD	TBD	TBD	
Packet Switched Data	[16kbps]	32ksps	64kbps	Standard Test
	TBD	TBD	TBD	

4.2 Maximum Output Power

4.2.1 Definition and applicability

The maximum output power and its tolerance are defined according to the Power Class of the MS.

The maximum output power refers to the measure power when averaged over the transmit slot at the maximum power control setting.

For MS using directive antennas for transmission, a class dependent limit will be placed on the maximum Effective Isotropic Radiated Power (EIRP).

The requirements and this test apply to all types of UTRA for the MS.

4.2.2 Conformance requirements

The tolerance of the MS maximum output power shall be below the shown value in Table 4.2.1 even for the multi-code transmission mode.

<Editor's Note: This requirements feels slightly strange. Since the word "tolerance" means allowable range of errors, this should be changed as follows:

*The **error** of the MS maximum output power shall **be within** (or **not exceed**) the shown **tolerance** in Table 4.2.1 even for the multi-code transmission mode.*

In the original requirements, the case that the error equals the shown value is not allowed. On the otherhand, in the changed requirements, that case is allowed.>

Table 4.2.1 Maximum Output Power

Power Class	Maximum output power	Tolerance
1	+33 dBm	± [2] dB
2	+27 dBm	± [2] dB
3	+24 dBm	± [2] dB
4	+21 dBm	± 2 dB

The reference for this requirement is 25.101 §6.2.

4.2.3 Test purpose

To verify the error of the MS maximum output power does not exceed the prescribed tolerance in Table 4.2.1.

4.2.4 Method of test

4.2.4.1 Initial conditions

- (1) Connect the SS to the MS antenna connector as shown in Figure A.1.
- (2) A call is set up according to the Generic call setup procedure using parameters as specified in Table 4.2.2.
- (3) Enter the MS into loopback test mode and start the loopback test.

See [3] iTS-T1.001 Logical Test Interface for details regarding generic call setup procedure and loopback test.

<Editor's Note: The generic call setup procedure is currently specified in Annex A of iTS-T1.001.>

Table 4.2.2 Test parameters for Maximum Output Power

Parameter	Level / Status	Unit
\hat{I}_{or}	[-93]	dBm/4.096MHz
$\frac{\text{Perch_Ec}}{I_{or}}$	[-1]	dB
$\frac{\text{DPCH_Ec}}{I_{or}}$	[-7]	dB
Forward Channel symbol rate	[32]	ksps
Reverse Channel bit rate	[64]	kbps
User bit rate	[12.2]	kbps
Closed Power Control	Enabled	

4.2.4.2 Procedure

- (1) Set and send continuously TPC bits as '11' to the MS.
- (2) Measure the output power of the MS by Tester. The output power shall be averaged over the transmit one timeslot.

4.2.5 Test Requirements

The error of measured output power, derived in step (2), shall not exceed the prescribed tolerance in Table 4.2.1.

4.3 Frequency Stability

4.3.1 Definition and applicability

The frequency stability is the difference in modulated carrier frequency with AFC ON between the RF transmission from the MS and either:

- the RF transmission from the BS, or
- the nominal frequency for the UARFCN used.

These signals will have an apparent error due to BS frequency.

The requirements and this test apply to all types of UTRA for the MS.

4.3.2 Conformance requirements

The MS carrier frequency shall be accurate to within $\pm 0,1$ ppm, or accurate to within $\pm 0,1$ ppm compared to signals received from the BS.

The reference for this requirement is 25.101 §6.3.

4.3.3 Test purpose

To verify that the MS carrier frequency error does not exceed $\pm 0,1$ ppm.

4.3.4 Method of test

4.3.4.1 Initial conditions

- (1) Connect the SS to the MS antenna connector as shown in Figure A.1.
- (2) A call is set up according to the Generic call setup procedure using parameters as specified in Table 4.3.
- (3) Enter the MS into loopback test mode and start the loopback test.

See [3] iTS-T1.001 Logical Test Interface for details regarding generic call setup procedure and loopback test.

<Editor's Note: The generic call setup procedure is currently specified in Annex A of iTS-T1.001.>

Table 4.3 Test parameters for Frequency Stability

Parameter	Level / Status	Unit
\hat{I}_{or}	[-103]	dBm/4.096MHz
$\frac{\text{Perch_Ec}}{I_{or}}$	[-1]	dB
$\frac{\text{DPCH_Ec}}{I_{or}}$	[-7]	dB
Forward Channel symbol rate	[32]	ksps
Reverse Channel bit rate	[64]	kbps
User bit rate	[12.2]	kbps
Closed Power Control	Enabled	
AFC	ON	
Modulation	ON	

4.3.4.2 Procedure

- (1) Measure the frequency error Δf , at the MS antenna connector by Tester.
Since counter method leads an incorrect result, EVM method shall be used.

<Editor's Note> The details of this procedure should be defined.

4.3.5 Test Requirements

For all measured bursts, the frequency error, derived in step (1), shall not exceed $10E-7$.

4.4 Output Power Dynamics in the Uplink

Power control is used to limit the interference level

4.4.1 Open Loop Power Control in the Uplink

4.4.1.1 Definition and applicability

Open loop power control in the uplink is the ability of the MS transmitter to sets its output power to a specific value. This function is used for RACH transmission and based on the information from BS using BCCH and the downlink received signal power level of the PCCPCH. The information from BS includes transmission power of PCCPCH and uplink interference power level.

The requirements and this test apply to all types of UTRA for the MS.

4.4.1.2 Conformance requirements

The MS open loop power control tolerance is given in Table 4.4.1.1.

Table 4.4.1.1 Open loop power control tolerance

Normal conditions	± 9 dB
Extreme conditions	± 12 dB

The reference for this requirement is 25.101 §6.4.1.

4.4.1.3 Test purpose

To verify that the MS open loop power control tolerance does not exceed the described value shown in Table 4.4.1.1.

4.4.1.4 Method of test

4.4.1.4.1 Initial conditions

- (1) Connect the SS to the MS antenna connector as shown in Figure A.1.
- (2) A call is set up according to the Generic call setup procedure using parameters as specified in Table 4.4.1.2.
- (3) Enter the MS into loopback test mode and start the loopback test.

See [3] iTS-T1.001 Logical Test Interface for details regarding generic call setup procedure and loopback test.

<Editor's Note: The generic call setup procedure is currently specified in Annex A of iTS-T1.001.>

Table 4.4.1.2 Test parameters for Open Loop Power Control

Parameter	Level / Status	Unit
\hat{I}_{or}	[] to []	dBm/4.096MHz
$\frac{\text{Perch_Ec}}{I_{or}}$	[-1]	dB
$\frac{\text{DPCH_Ec}}{I_{or}}$	[-7]	dB
Forward Channel symbol rate	[32]	ksps
Reverse Channel bit rate	[64]	kbps
User bit rate	[12.2]	kbps
Closed Power Control	Disabled	

4.4.1.4.2 Procedure

- (1) Adjust the TX output level of the SS to obtain \hat{I}_{or} at the MS antenna connector. \hat{I}_{or} shall be selected out of the range that is shown in the table. [TBD]
- (2) Measure the output power of the MS during 1 frame at the MS antenna connector by Tester.
- (3) Repeat the above measurement several times. In this time, \hat{I}_{or} shall be varied over the range. [TBD]
- (4) RACH shall be used for this measurement.

4.4.1.5 Test Requirements

The error of measured output power, derived in step (2), shall not exceed the prescribed tolerance in Table 4.4.1.1.

4.4.2 Closed Loop Power Control in the Uplink

4.4.2.1 Definition and applicability

Closed loop power control in the uplink is the ability of the MS transmitter to adjust its output power in accordance with the TPC symbols received in the downlink.

The power control step is the minimum step change in the uplink- transmitter output power in response to a TPC message.

The requirements and this test apply to all types of UTRA for the MS.

4.4.2.2 Conformance requirements

The MS transmitter shall have the capability of setting the closed loop output power with a step size of 1 dB.

- The tolerance of the transmitter output power due to closed loop power control shall be within the range shown in Table 4.4.2.1.
- The average rate of change in mean power shall be greater than [8.0] dB per [10] slots and less than [12.0] dB per [10] slots
- Following the reception of a valid power control bit, the mean output power of the MS shall be within [0.3] dB of its final value in less than [62.5] μ s from the beginning of the next slot.

The maximum rate of change for the transmitter power control step is 1.6kHz (1/0.625msec).

Table 4.4.2.1 Transmitter power control tolerance

TPC Symbol in the forward-link	Transmitter power control range	
	Lower	Upper
11	+ [0.5]dB	+ [1.5]dB
00	- [0.5]dB	- [1.5]dB

The reference for this requirement is 25.101 §6.4.3.1.

4.4.2.3 Test purpose

To verify that the MS closed loop power control size and response is meet to the described value shown in clause 4.4.2.2.

4.4.2.4 Method of test

4.4.2.4.1 Initial conditions

- Connect the SS to the MS antenna connector as shown in Figure A.1.
- A call is set up according to the Generic call setup procedure using parameters as specified in Table 4.4.2.2.
- Enter the MS into loopback test mode and start the loopback test.

See [3] iTS-T1.001 Logical Test Interface for details regarding generic call setup procedure and loopback test.

<Editor's Note: The generic call setup procedure is currently specified in Annex A of iTS-T1.001.>

Table 4.4.2.2 Test parameters for Closed Loop Power Control

Parameter	Level / Status	Unit
\hat{I}_{or}	[-93]	dBm/4.096MHz
$\frac{\text{Perch_Ec}}{I_{or}}$	[-1]	dB
$\frac{\text{DPCH_Ec}}{I_{or}}$	[-7]	dB
Forward Channel symbol rate	[32]	ksps
Reverse Channel bit rate	[64]	kbps
User bit rate	[12.2]	kbps
Closed Power Control	Enabled	

4.4.2.4.2 Procedure

- (1) Set and send alternating TPC bits from the SS, followed by [10] consecutive '11' s TPC bits, followed by [10]
- (2) Measure the output power of the MS during every slot (0.625msec) at the MS antenna connector by Tester.
- (3) Measure the transient time from the beginning of the next slot to the time when the output power shall be within the defined tolerance of its final value.

<Editor's Note> *Test procedures for the conformance requirement (a) and (c) are not clearly specified yet. Individual power control cycles test may be unnecessary because above procedure includes the cycle verification.*

4.4.2.5 Test Requirements

- (a) For all measured slots, the difference of mean output power between the adjacent slots, derived in step (2), shall not exceed the prescribed range in Table 4.4.2.1.
- (b) For all measured cycles, the average rate of change in mean power, derived in step (2), shall be greater than [8.0] dB per [10] slots and less than [12.0] dB per [10] slots.
- (c) For all measured slots, following the reception of a valid power control bit, the mean output power of the MS, derived in step (3), shall be within [0.3] dB of its final value in less than [62.5] μ s from the beginning of the next slot.

4.4.3 Minimum Output Power

4.4.3.1 Definition and applicability

The minimum controlled output power of the MS is when the power control setting is set to a minimum value. This is when both the closed loop and open loop power control indicate a minimum transmit output power is required.

The requirements and this test apply to all types of UTRA for the MS.

4.4.3.2 Conformance requirements

The minimum transmit power shall be better than -44 dBm /4.096MHz.

The reference for this requirement is 25.101 §6.4.4.

4.4.3.3 Test purpose

To verify that the MS minimum transmit power is below -44 dBm /4.096MHz.

4.4.3.4 Method of test

4.4.3.4.1 Initial conditions

- (1) Connect the SS to the MS antenna connector as shown in Figure A.1.
- (2) A call is set up according to the Generic call setup procedure using parameters as specified in Table 4.4.3.
- (3) Enter the MS into loopback test mode and start the loopback test.

See [3] iTS-T1.001 Logical Test Interface for details regarding generic call setup procedure and loopback test.

<Editor's Note: The generic call setup procedure is currently specified in Annex A of iTS-T1.001.>

Table 4.4.3 Test parameters for Minimum Output Power

Parameter	Level / Status	Unit
\hat{I}_{or}	[-93]	dBm/4.096MHz
$\frac{Perch_Ec}{I_{or}}$	[-1]	dB
$\frac{DPCH_Ec}{I_{or}}$	[-7]	dB
Forward Channel symbol rate	[32]	ksps
Reverse Channel bit rate	[64]	kbps
User bit rate	[12.2]	kbps
Closed Power Control	Enabled	

4.4.3.4.2 Procedure

- (1) Set and send continuously TPC bits as '00' to the MS.
- (2) Measure the output power of the MS by Tester.

<Editor's Note> Both the closed loop and open loop power control indicate a minimum transmit output power is required. And the measurement period should be defined.

4.4.3.5 Test Requirements

The measured output power, derived in step (2), shall below $-44 \text{ dBm}/4.096\text{MHz}$.

4.5 Transmit OFF Power

<Editor's Note> This title should be changed to "Transmit ON/OFF Power" and this clause should be separated into two sub-clauses: "Transmit OFF Power" and "Transmit ON/OFF Time mask".

4.5.1 Definition and applicability

The transmit OFF power state is when the MS does not transmit except during uplink DTX mode. This parameter is defined as the maximum output transmit power within the channel bandwidth when the transmitter is OFF.

The requirements and this test apply to all types of UTRA for the MS.

4.5.2 Conformance requirements

The requirement for the transmit OFF power shall be better than -50 dBm /4.096 MHz.

The reference for this requirement is 25.101 §6.5.1.

4.5.3 Test purpose

To verify that the MS transmit OFF power is below -50 dBm /4.096 MHz.

4.5.4 Method of test

4.5.4.1 Initial conditions

- (1) Connect the SS to the MS antenna connector as shown in Figure A.1.
- (2) A call is set up according to the Generic call setup procedure using parameters as specified in Table 4.5.
- (3) Enter the MS into loopback test mode and start the loopback test.

See [3] iTS-T1.001 Logical Test Interface for details regarding generic call setup procedure and loopback test.

<Editor's Note: The generic call setup procedure is currently specified in Annex A of iTS-T1.001.>

Table 4.5 Test parameters for Transmit OFF Power

Parameter	Level / Status	Unit
\hat{I}_{or}	[-93]	dBm/4.096MHz
$\frac{\text{Perch_Ec}}{I_{or}}$	[-1]	dB
$\frac{\text{DPCH_Ec}}{I_{or}}$	[-7]	dB
Forward Channel symbol rate	[32]	ksps
Reverse Channel bit rate	[64]	kbps
User bit rate	[12.2]	kbps
Closed Power Control	Enabled	

4.5.4.2 Procedure

- (1) Send release message to the MS to stop transmitting.
- (2) Measure the leakage power within the transmission band from the MS by the Tester.

<Editor's Note> "Closed Power Control: Enabled" might be unnecessary in this measurement.

4.5.5 Test Requirements

The measured leakage power, derived in step (2), shall below -50 dBm/4.096MHz.

<Editor's Note> The following is an example for "Transmit ON/OFF Time mask" sub-clause.

4.5.X Transmit ON/OFF Time mask

4.5.X.1 Definition and applicability

The time mask for transmit ON/OFF defines the ramping time allowed for the MS between transmit OFF power and transmit ON power. Possible ON/OFF scenarios are RACH or uplink slotted mode

The requirements and this test apply to all types of UTRA for the MS.

4.5.X.2 Conformance requirements

The transmit power levels versus time should meet the mask specified in Figure 4.5

The reference for this requirement is 25.101 §6.5.2.

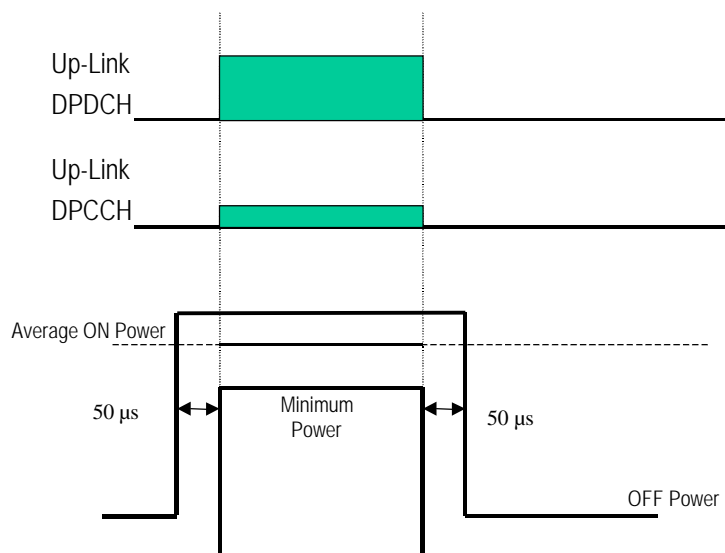

Figure 4.5 Transmit ON/OFF template

4.5.X.3 Test purpose

To verify that the MS transmit ON/OFF power levels versus time meets the described mask shown in Figure 4.5.

4.5.X.4 Method of test

4.5.X.4.1 Initial conditions

[TBD]

4.5.X.4.2 Procedure

[TBD]

4.5.X.5 Test Requirements

[TBD]

4.6 DTX

4.6.1 Definition and applicability

DTX is used to minimize the interference between MS(s) by reducing the MS transmit power when voice, user or control information is not present.

The requirements and this test apply to all types of UTRA for the MS.

4.6.2 Conformance requirements

The transmitting power ratio and the timing should be in the range indicated in Figure 4.6.

The reference for this requirement is 25.101 §6.5.3.

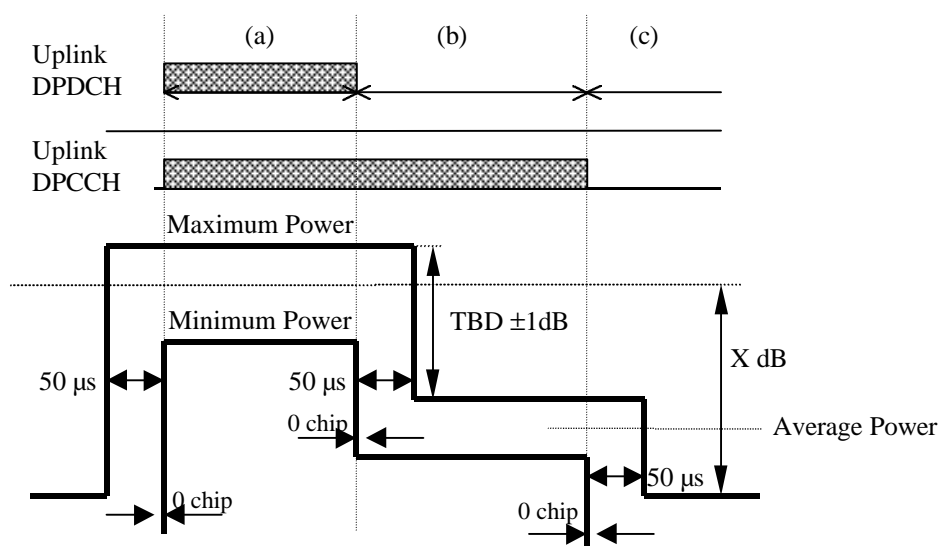

Figure 4.6 DTX template

Note

- (a) Both DPDCH and DPCCH transmission is ON in the up link.
- (b) In case of no information after (a), DPDCH transmission is OFF
- (c) In case synchronism is out of range after section (b), DPCCH transmission is OFF in up link.

4.6.3 Test purpose

To verify that the MS transmitting power ratio and the timing are in the range indicated in Figure 4.6.

4.6.4 Method of test

4.6.4.1 Initial conditions

- (1) Connect the SS to the MS antenna connector as shown in Figure A.1.

- (2) A call is set up according to the Generic call setup procedure using parameters as specified in Table 4.6.
- (3) Enter the MS into loopback test mode and start the loopback test.

See [3] iTS-T1.001 Logical Test Interface for details regarding generic call setup procedure and loopback test.

<Editor's Note: The generic call setup procedure is currently specified in Annex A of iTS-T1.001.>

Table 4.6 Test parameters for DTX

Parameter	Level / Status	Unit
\hat{I}_{or}	[-93]	dBm/4.096MHz
$\frac{Perch_Ec}{I_{or}}$	[-1]	dB
$\frac{DPCH_Ec}{I_{or}}$	[-7]	dB
Forward Channel symbol rate (PTCH)	[32]	ksps
Reverse Channel bit rate (PTCH)	[64]	kbps
Closed Power Control	Enabled	

4.6.4.2 Procedure

- (1) Measure the average output power at the antenna connector of the MS by Tester in three cases, both DPDCH and DPCCH are ON, only DPCCH is ON and both channels are OFF.

4.6.5 Test Requirements

For all measured bursts, the output power ratio and the timing, derived in step (1), shall be in the range in Figure 4.6.1.

4.7 Occupied Bandwidth

4.7.1 Definition and applicability

Occupied bandwidth is a measure of the bandwidth containing 99% of the total integrated power of the transmitted spectrum, centered on the assigned channel frequency.

The requirements and this test apply to all types of UTRA for the MS.

4.7.2 Conformance requirements

The occupied channel bandwidth is less than 5 MHz based on a chip rate of 4.096 Mcps.

The reference for this requirement is 25.101 §6.6.1.

<Editor's Note: Since a word "shall" is not used in this description, it is not clear whether this specification is mandatory or not.>

4.7.3 Test purpose

To verify that the MS occupied channel bandwidth is less than 5 MHz based on a chip rate of 4.096 Mcps.

4.7.4 Method of test

4.7.4.1 Initial conditions

[TBD]

4.7.4.2 Procedure

[TBD]

4.7.5 Test Requirements

[TBD]

4.8 Adjacent Channel Leakage Power Ratio (ACLR)

4.8.1 Leakage Power due to Modulation

4.8.1.1 Definition and applicability

ACLR due to modulation is the ratio of the transmitted power to the power measured after a receiver filter in the adjacent channel(s) in the continuous transmission mode. Both the transmitted power and the received power are measured with a filter response that is [normally rectangular] with a noise power bandwidth equal to the chip rate.

The requirements and this test apply to all types of UTRA for the MS.

4.8.1.2 Conformance requirements

Table 4.8.1 MS ACLR due to modulation

MS channel	ACLR limit
± First adjacent channel	[-] dB or -50dBm/4.096MHz which ever is higher
± Second adjacent channel	[-] dB or -50dBm/4.096MHz which ever is higher

The reference for this requirement is 25.101 §6.6.2.2.

Note

- 1) The possibility is being considered of dynamically relaxing the ACLR requirements for MS(s) under conditions when this would not lead to significant interference (with respect to other system scenario or UMTS operators). This would be carried out under network control, primarily to facilitate reduction in MS power consumption.
- 2) The ACLR value is FFS based on system scenario and implementation issues.

4.8.1.3 Test purpose

To verify that the MS ACLR due to modulation does not exceed prescribed limit shown in Table 4.8.1.

4.8.1.4 Method of test

4.8.1.4.1 Initial conditions

- (1) Connect the SS to the MS antenna connector as shown in Figure A.1.
- (2) A call is set up according to the Generic call setup procedure using parameters as specified in Table 4.8.2.
- (3) Enter the MS into loopback test mode and start the loopback test.

See [3] iTS-T1.001 Logical Test Interface for details regarding generic call setup procedure and loopback test.

<Editor's Note: The generic call setup procedure is currently specified in Annex A of iTS-T1.001.>

Table 4.8.2 Test parameters for Leakage Power due to Modulation

Parameter	Level / Status	Unit
\hat{I}_{or}	[-93]	dBm/4.096MHz
$\frac{\text{Perch_Ec}}{I_{or}}$	[-1]	dB
$\frac{\text{DPCH_Ec}}{I_{or}}$	[-7]	dB
Forward Channel symbol rate	[32]	ksps
Reverse Channel bit rate	[64]	kbps
User bit rate	[12.2]	kbps
Closed Power Control	Enabled	
DTX mode	Off	

4.8.1.4.2 Procedure

- (1) Set and send continuously TPC bits as '11' to the MS until the MS output power shall be maximum level.
- (2) Measure the power within the bandwidth of current carrier through a matched filter (RRC 0.22).
- (3) Measure the power fallen in the bandwidth of the first adjacent channels and the second adjacent channels through a matched filter (RRC 0.22).
- (4) Calculate the ratio of the power between the values measured in '(2)' and '(3)'.

4.8.1.5 Test Requirements

The measured ACLR, derived in step (3) and (4), shall not exceed the limit in Table 4.8.1.

4.8.2 Leakage Power due to Switching

<Editor's Note: This specification in the referred document 25.101 is unified with the prescribed specification of Leakage Power due to Modulation. Method of test may be different from each other.>

4.8.2.1 Definition and applicability

ACLR due to switching is the ratio of the transmitted power to the power measured after a receiver filter in the adjacent channel(s) nearby the rising or falling edge in the discontinuous transmission mode. Both the transmitted power and the received power are measured with a filter response that is [normally rectangular] with a noise power bandwidth equal to the chip rate.

The requirements and this test apply to all types of UTRA for the MS.

4.8.2.2 Conformance requirements

Table 4.8.3 MS ACLR due to switching

MS channel	ACLR limit
± First adjacent channel	[-] dB or -50dBm/4.096MHz which ever is higher
± Second adjacent channel	[-] dB or -50dBm/4.096MHz which ever is higher

The reference for this requirement is 25.101 §6.6.2.2.

Note

- 1) The possibility is being considered of dynamically relaxing the ACLR requirements for MS(s) under conditions when this would not lead to significant interference (with respect to other system scenario or UMTS operators). This would be carried out under network control, primarily to facilitate reduction in MS power consumption.
- 2) The ACLR value is FFS based on system scenario and implementation issues.

4.8.2.3 Test purpose

To verify that the MS ACLR due to switching does not exceed prescribed limit shown in Table 4.8.3.

4.8.2.4 Method of test

4.8.2.4.1 Initial conditions

- (1) Connect the SS to the MS antenna connector as shown in Figure A.1.
- (2) A call is set up according to the Generic call setup procedure using parameters as specified in Table 4.8.4.
- (3) Enter the MS into loopback test mode and start the loopback test.

See [3] iTS-T1.001 Logical Test Interface for details regarding generic call setup procedure and loopback test.

<Editor's Note: The generic call setup procedure is currently specified in Annex A of iTS-T1.001.>

Table 4.8.4 Test parameters for Leakage Power due to Switching

Parameter	Level / Status	Unit
\hat{I}_{or}	[-93]	dBm/4.096MHz
$\frac{\text{Perch_Ec}}{I_{or}}$	[-1]	dB
$\frac{\text{DPCH_Ec}}{I_{or}}$	[-7]	dB
Forward Channel symbol rate	[32]	ksps
Reverse Channel bit rate	[64]	kbps
User bit rate	[12.2]	kbps
Closed Power Control	Enabled	
DTX mode	On	

4.8.2.4.2 Procedure

- (1) Set and send continuously TPC bits as '11' to the MS until the MS output power shall be maximum level.
- (2) Measure the wanted-channel-power within the bandwidth of current carrier through a matched filter (RRC 0.22). Take the average power within the DTX switched-on frame.
- (3) Measure the power fallen in the bandwidth of the first adjacent channels and the second adjacent channels through a matched filter (RRC 0.22). The weighting method is as follows: The power samples are averaged over one symbol period. The measurement period is centered around a rising and falling edge of the DTX switched frame. Take the maximum value of the averages.
- (4) Calculate the ratio of the power between the values measured in '(2)' and '(4)'.

4.8.2.5 Test Requirements

The measured ACLR, derived in step (3) and (4), shall not exceed the limit in Table 4.8.3.

4.9 Spurious Emissions

4.9.1 Definition and applicability

Spurious emissions are emissions which are caused by unwanted transmitter effects such as harmonics emission, parasitic emission, intermodulation products and frequency conversion products, but exclude out of band emissions.

The frequency boundary and the detailed transitions of the limits between the requirement for out band emissions and spectrum emissions are based on ITU-R Recommendations SM.329.

The requirements and this test apply to all types of UTRA for the MS.

4.9.2 Conformance requirements

Table 4.9.1a Spurious emissions requirements

Frequency Bandwidth	Resolution Bandwidth	Minimum requirement
$9\text{kHz} \leq f < 150\text{kHz}$	1 kHz	-36dBm
$150\text{kHz} \leq f < 30\text{MHz}$	10 kHz	-36dBm
$30\text{MHz} \leq f < 1000\text{ MHz}$	100kHz	-36dBm
$1\text{GHz} \leq f < 11\text{GHz}$	1MHz	-30dBm

Table 4.9.1b Spurious emissions regional requirements

Frequency Bandwidth	Resolution Bandwidth	Minimum requirement
$1893.5\text{ MHz} < f < 1910\text{ MHz}$	300 kHz	-40dBm
$925\text{ MHz} < f < 935\text{ MHz}$	100 kHz	-67dBm,*
$935\text{ MHz} < f < 960\text{ MHz}$	100 kHz	-79dBm,*
$1805\text{ MHz} < f < 1880\text{ MHz}$	100 kHz	-71dBm,*

* As exceptions, up to five measurements with a level up to -36 dBm are permitted for each ARFCN used in the measurement.

The reference for this requirement is 25.101 §6.6.3.

4.9.3 Test purpose

To verify that the MS spurious emissions do not exceed described value shown in Table 4.9.1a and Table 4.9.1b.

4.9.4 Method of test

4.9.4.1 Initial conditions

- (1) Connect the SS to the MS antenna connector as shown in Figure A.1.
- (2) A call is set up according to the Generic call setup procedure using parameters as specified in Table 4.9.2.
- (3) Enter the MS into loopback test mode and start the loopback test.

See [3] iTS-T1.001 Logical Test Interface for details regarding generic call setup procedure and loopback test.

<Editor's Note: The generic call setup procedure is currently specified in Annex A of iTS-T1.001.>

Table 4.9.2 Test parameters for Spurious Emissions

Parameter	Level / Status	Unit
\hat{I}_{or}	[-93]	dBm/4.096MHz
$\frac{\text{Perch_Ec}}{I_{or}}$	[-1]	dB
$\frac{\text{DPCH_Ec}}{I_{or}}$	[-7]	dB
Forward Channel symbol rate	[32]	ksps
Reverse Channel bit rate	[64]	kbps
User bit rate	[12.2]	kbps
Closed Power Control	Enabled	

4.9.4.2 Procedure

- (1) Set and send continuously TPC bits as '11' to the MS until the MS output power shall be maximum level.
- (2) Sweep the spectrum analyzer over a frequency range and measure the average power of spurious emission.

4.9.5 Test Requirements

The measured average power of spurious emission, derived in step (2), shall not exceed the described value in Table 4.9.1a and 4.9.1b.

4.10 Transmit Intermodulation

4.10.1 Definition and applicability

The transmit intermodulation performance is a measure of the capability of the transmitter to inhibit the generation of signals in its non linear elements caused by presence of the wanted signal and an interfering signal reaching the transmitter via the antenna.

MS(s) transmitting in close vicinity of each other can produce intermodulation products, which can fall into the MS, or BS receive band as an unwanted interfering signal. The MS transmit intermodulation attenuation is defined by the ratio of the output power of the wanted signal to the output power of the intermodulation product when an interfering CW signal is added at a level below the wanted signal.

The requirements and this test apply to all types of UTRA for the MS.

4.10.2 Conformance requirements

The MS transmit intermodulation shall not exceed the described value in Table 4.10.1. Table 4.10.1 Transmit Intermodulation

CW Signal Frequency Offset from Transmitting Carrier	5MHz	10MHz
Minimum Requirement	[-35]dBc	[-45]dBc

The reference for this requirement is 25.101 §6.7.

4.10.3 Test purpose

To verify that the MS transmit intermodulation does not exceed the described value in Table 4.10.1.

4.10.4 Method of test

4.10.4.1 Initial conditions

- (1) Connect the SS to the MS antenna connector as shown in Figure A.2.
- (2) A call is set up according to the Generic call setup procedure using parameters as specified in Table 4.10.2.
- (3) Enter the MS into loopback test mode and start the loopback test.

See [3] iTS-T1.001 Logical Test Interface for details regarding generic call setup procedure and loopback test.

<Editor's Note: The generic call setup procedure is currently specified in Annex A of iTS-T1.001.>

Table 4.10.2 Test parameters for Transmit Intermodulation

Parameter	Level / Status	Unit
\hat{I}_{or}	[-93]	dBm/4.096MHz
$\frac{\text{Perch_Ec}}{I_{or}}$	[-1]	dB
$\frac{\text{DPCH_Ec}}{I_{or}}$	[-7]	dB
Forward Channel symbol rate	[32]	ksps
Reverse Channel bit rate	[64]	kbps
User bit rate	[12.2]	kbps
Closed Power Control	Enabled	

4.10.4.2 Procedure

- (1) Set and send continuously TPC bits as '11' to the MS until the MS output power shall be maximum level.
- (2) Measure the average output power of the MS by spectrum analyzer.
- (3) Set the frequency of the CW generator to the offset 1 or offset 2 as shown in Table 4.10.3.
- (4) Check around the frequency of the carrier and [3rd] IM, then measure the average power of transmitting intermodulation.
- (5) Repeat the measurement with another tone offset.

Table 4.10.3 Parameters of Interfering Signal

Tone Power	-40	dBc
Tone Offset 1 from Transmitting Carrier	5	MHz
Tone Offset 2 from Transmitting Carrier	10	MHz

4.10.5 Test Requirements

The measured average power of transmit intermodulation, derived in step (4), shall not exceed the described value in Table 4.10.1.

4.11 Modulation Accuracy

<Editor's Note> This clause should be separated into two sub-clauses: "Error Vector" and "Peak code Domain error".

4.11.1 Definition and applicability

The modulation accuracy is a measure of the difference between the measured waveform and the theoretical modulated waveform (the error vector). It is the square root of the ratio of the mean error vector power to the mean reference signal power expressed as a %. The measurement interval is one power control group (timeslot).

The requirements and this test apply to all types of UTRA for the MS.

4.11.2 Conformance requirements

The modulation accuracy shall not exceed 17.5 % based on the test parameters detailed in Table 4.11.

The reference for this requirement is 25.101 §6.8.2.

Note

- 1) Measurement channel is based on mapping of a 12.2 kbps voice channel

4.11.3 Test purpose

To verify that the MS modulation accuracy does not exceed 17.5 % based on the test parameters shown in Table 4.11.

4.11.4 Method of test

4.11.4.1 Initial conditions

- (1) Connect the SS to the MS antenna connector as shown in Figure A.1.
- (2) A call is set up according to the Generic call setup procedure using parameters as specified in Table 4.11.
- (3) Enter the MS into loopback test mode and start the loopback test.

See [3] iTS-T1.001 Logical Test Interface for details regarding generic call setup procedure and loopback test.

<Editor's Note: The generic call setup procedure is currently specified in Annex A of iTS-T1.001.>

Table 4.11 Test parameters for Modulation Accuracy

Parameter	Level / Status	Unit
\hat{I}_{or}	[-93]	dBm/4.096MHz
$\frac{\text{Perch_Ec}}{I_{or}}$	[-1]	dB
$\frac{\text{DPCH_Ec}}{I_{or}}$	[-7]	dB
Output power	[MS maximum power]	dBm
DPCCH/DPDCH	[-6]	dB
Forward Channel symbol rate	[32]	ksps
Reverse Channel bit rate	[64]	kbps
User bit rate	[12.2]	kbps
Closed Power Control	Enabled	

4.11.4.2 Procedure

- (1) Measure the EVM (Error vector magnitude), at the MS antenna connector by Tester.

4.11.5 Test Requirements

The measured EVM, derived in step (1), shall not exceed 17.5%.

<Editor's Note> The following is an example for "Peak code Domain error" sub-clause.

4.11.X Peak code Domain error

4.11.X.1 Definition and applicability

The code domain error is computed by projecting the error vector power onto the code domain at the maximum spreading factor. The error vector for each power code is defined as the ratio to the mean power of the reference waveform expressed in dB. The peak code domain error is defined as the maximum value for the code domain error. The measurement interval is one power control group (timeslot)

The requirement for peak code domain error is only applicable for multi-code transmission.

The requirements and this test apply to all types of UTRA for the MS.

4.11.X.2 Conformance requirements

The peak code domain error shall not exceed [] dB.

The reference for this requirement is 25.101 §6.8.3.

4.11.X.3 Test purpose

To verify that the MS peak code domain error does not exceed [] dB.

4.11.X.4 Method of test

4.11.X.4.1 Initial conditions

[TBD]

4.11.X.4.2 Procedure

[TBD]

4.11.X.5 Test Requirements

[TBD]

5 Receiver Characteristics

5.1 General

Receiving performance test of the MS is implemented during communicating with the SS via air interface. The procedure is used normal call protocol until the MS is communicating on traffic channel basically. On the traffic channel, the MS provides special function for testing that is called Logical Test Interface and the MS is tested using this function. (Refer to iTS-T1.001 Logical Test Interface)

Transmitting or receiving bit/symbol rate for test channel is shown in Table 5.1.

Table 5.1 Bit / Symbol rate for Test Channel

Type of User Information	User bit rate	Forward DPCH symbol rate	Reverse DPCH bit rate	Remarks
Speech	12.2kbps	32ksps	64kbps	Standard Test
Circuit Switched Data	TBD	TBD	TBD	
Packet Switched Data	[16kbps]	32ksps	64kbps	Standard Test
	TBD	TBD	TBD	

5.2 Reference Sensitivity Level

5.2.1 Definition and applicability

The static reference sensitivity is the minimum receiver input power measured at the antenna port at which the Bit Error Rate (BER) does not exceed a specific value

The requirements and this test apply to all types of UTRA for the MS.

5.2.2 Conformance requirements

The BER shall not exceed 0.001 for the parameters specified in Table 5.2.

The reference for this requirement is 25.101 §7.3.

Note

- 1) Measurement channel is based on mapping of a 12.2 kbps voice channel

5.2.3 Test purpose

To verify that the MS BER does not exceed 0.001 for the parameters specified in Table 5.2.

5.2.4 Method of test

5.2.4.1 Initial conditions

- (1) Connect the SS to the MS antenna connector as shown in Figure A.3.
- (2) A call is set up according to the Generic call setup procedure using parameters as specified in Table 5.2.
- (3) Enter the MS into loopback test mode and start the loopback test.

See [3] iTS-T1.001 Logical Test Interface for details regarding generic call setup procedure and loopback test.

<Editor's Note: The generic call setup procedure is currently specified in Annex A of iTS-T1.001.>

Table 5.2 Test parameters for Reference Sensitivity Level

Parameter	Level / Status	Unit
\hat{I}_{or}	-110	dBm/4.096MHz
$\frac{PCCPCH_Ec}{I_{or}}$	-1	dB
$\frac{DPCH_Ec}{I_{or}}$	-7	dB
Forward Channel symbol rate	[32]	ksps
Reverse Channel bit rate	[64]	kbps
User bit rate	[12.2]	kbps

5.2.4.2 Procedure

- (1) Measure the BER of DCH received from the MS at the SS.

<Editor's Note> If the MS does not provide the data transmission rate combination that UL is equal or higher than DL, the BER in DL should be measured by the MS itself and the results should be reported to the SS through UL.

5.2.5 Test Requirements

The measured BER, derived in step (1), shall not exceed 0.001.

5.3 Maximum Input Level

5.3.1 Definition and applicability

This is defined as the maximum receiver input power at the MS antenna port which does not degrade the specified BER performance.

The requirements and this test apply to all types of UTRA for the MS.

5.3.2 Conformance requirements

The BER shall not exceed 0.001 for the parameters specified in Table 5.3.

The reference for this requirement is 25.101 §7.4.

Note

- 1) Since the spreading factor is large ($10\log(\text{SF})=21\text{dB}$), the majority of the total input signal consists of the OCNS interference. <Change OCNS definition>
- 2) Measurement channel is based on mapping of a 12.2 kbps voice channel

5.3.3 Test purpose

To verify that the MS BER does not exceed 0.001 for the parameters specified in Table 5.3.

5.3.4 Method of test

5.3.4.1 Initial conditions

- (1) Connect the SS to the MS antenna connector as shown in Figure A.3.
- (2) A call is set up according to the Generic call setup procedure using parameters as specified in Table 5.3.
- (3) Enter the MS into loopback test mode and start the loopback test.

See [3] iTS-T1.001 Logical Test Interface for details regarding generic call setup procedure and loopback test.

<Editor's Note: The generic call setup procedure is currently specified in Annex A of iTS-T1.001.>

Table 5.3 Test parameters for Maximum Input Level

Parameter	Level / Status	Unit
\hat{I}_{or}	[-25]	dBm/4.096MHz
$\frac{PCCPCH_Ec}{I_{or}}$	[-10]	dB
$\frac{DPCH_Ec}{I_{or}}$	[-19]	dB
$\frac{OCNS_Ec}{I_{or}}$	[-0.52]	dB
Forward Channel symbol rate	[32]	ksps
Reverse Channel bit rate	[64]	kbps
User bit rate	[12.2]	kbps

5.3.4.2 Procedure

- (1) Measure the BER of DCH received from the MS at the SS.

<Editor's Note> If the MS does not provide the data transmission rate combination that UL is equal or higher than DL, the BER in DL should be measured by the MS itself and the results should be reported to the SS through UL.

5.3.5 Test Requirements

The measured BER, derived in step (1), shall not exceed 0.001.

5.4 Adjacent Channel Selectivity (ACS)

5.4.1 Definition and applicability

Adjacent Channel Selectivity (ACS) is a measure of a receiver's ability to receive a W-CDMA signal at its assigned channel frequency in the presence of an adjacent channel signal at a given frequency offset from the center frequency of the assigned channel. ACS is the ratio of the receive filter attenuation on the assigned channel frequency to the receive filter attenuation on the adjacent channel(s).

The requirements and this test apply to all types of UTRA for the MS.

5.4.2 Conformance requirements

The BER shall not exceed 0.001 for the parameters specified in Table 5.4.1 and Table 5.4.2.

The reference for this requirement is 25.101 §7.5.

Note

- 1) Measurement channel is based on mapping of a 12.2 kbps voice channel

<Editor's Note> The modulation and spreading of the adjacent channel signal is not clear.

5.4.3 Test purpose

To verify that the MS BER does not exceed 0.001 for the parameters specified in Table 5.4.1 and Table 5.4.2.

5.4.4 Method of test

5.4.4.1 Initial conditions

- (1) Connect the SS to the MS antenna connector as shown in Figure A.4.
- (2) A call is set up according to the Generic call setup procedure using parameters as specified in Table 5.4.1.
- (3) Enter the MS into loopback test mode and start the loopback test.

See [3] iTS-T1.001 Logical Test Interface for details regarding generic call setup procedure and loopback test.

<Editor's Note: The generic call setup procedure is currently specified in Annex A of iTS-T1.001.>

Table 5.4.1 Test parameters for Adjacent Channel Selectivity

Parameter	Level / Status	Unit
\hat{I}_{or}	[-93]	dBm/4.096MHz
$\frac{PCCPCH_Ec}{I_{or}}$	[-1]	dB
$\frac{DPCH_Ec}{I_{or}}$	[-7]	dB
Forward Channel symbol rate	[32]	ksps
Reverse Channel bit rate	[64]	kbps
User bit rate	[12.2]	kbps

5.4.4.2 Procedure

- (1) Set the parameters of the interference signal generator as shown in Table 5.4.2.
- (2) Measure the BER of DCH received from the MS at the SS.

<Editor's Note> If the MS does not provide the data transmission rate combination that UL is equal or higher than DL, the BER in DL should be measured by the MS itself and the results should be reported to the SS through UL.

Table 5.4.2 Parameters of Interference Signal

Parameter	Level / Status	Unit
I_{oac} (Interference Signal)	[-52]	dBm/4.096MHz
F_{uw} (modulated)	[±5]	MHz

5.4.5 Test Requirements

The measured BER, derived in step (1), shall not exceed 0.001.

5.5 Blocking Characteristics

5.5.1 Definition and applicability

The blocking characteristic is a measure of the receiver's ability to receive a wanted signal at its assigned channel frequency in the presence of an unwanted interferer on frequencies other than those of the spurious response or the adjacent channels, without this unwanted input signal causing a degradation of the performance of the receiver beyond a specified limit. The blocking performance shall apply at all frequencies except those at which a spurious response occur.

The requirements and this test apply to all types of UTRA for the MS.

5.5.2 Conformance requirements

The BER shall not exceed 0.001 for the parameters specified in Table 5.5.1, Table 5.5.2 and Table 5.5.3.

The reference for this requirement is 25.101 §7.6.

5.5.3 Test purpose

To verify that the MS BER does not exceed 0.001 for the parameters specified in Table 5.5.1, Table 5.5.2 and Table 5.5.3.

5.5.4 Method of test

5.5.4.1 Initial conditions

- (1) Connect the SS to the MS antenna connector as shown in Figure A.5.
- (2) A call is set up according to the Generic call setup procedure using parameters as specified in Table 5.5.1.
- (3) Enter the MS into loopback test mode and start the loopback test.

See [3] iTS-T1.001 Logical Test Interface for details regarding generic call setup procedure and loopback test.

<Editor's Note: The generic call setup procedure is currently specified in Annex A of iTS-T1.001.>

Table 5.5.1 Test parameters for blocking characteristics

Parameter	Level	Unit
$\frac{\text{PCCPCH_Ec}}{I_{\text{or}}}$	[-1]	dB
$\frac{\text{DPCH_Ec}}{I_{\text{or}}}$	[-7]	dB
\hat{I}_{or}	[-107]	dBm/4.096MHz
$I_{\text{blocking modulated}}$	[-44]	dBm/4.096MHz
Blocking offset	[>15]	MHz

Table 5.5.2 Out of band blocking

Parameter	Band 1	Band 2	Unit
$\frac{\text{PCCPCH_Ec}}{I_{\text{or}}}$	[-1]	[-1]	dB
$\frac{\text{DPCH_Ec}}{I_{\text{or}}}$	[-7]	[-7 (*)]	dB
\hat{I}_{or}	[-107]	[-107]	dBm/4.096MHz
$I_{\text{blocking tone}}$	[-30]	[-15]	dBm
Blocking offset	[2025<f<2050] [2230<f<2255]	[f<2025 f>2255]	MHz

5.5.4.2 Procedure

- (1) Set the parameters of the CW generator or the interference signal generator as shown in Table 5.5.2 and Table 5.5.3.
- (2) Measure the BER of DCH received from the MS at the SS.

<Editor's Note> If the MS does not provide the data transmission rate combination that UL is equal or higher than DL, the BER in DL should be measured by the MS itself and the results should be reported to the SS through UL.

Table 5.5.2 Parameters of In-band blocking Signal

Parameter	Level	Unit
$I_{\text{blocking modulated}}$	[-44]	dBm/4.096MHz
Blocking offset	[>15]	MHz

Table 5.5.3 Parameters of Out of band blocking Signal

Parameter	Band 1	Band 2	Unit
$I_{\text{blocking tone}}$	[-30]	[-15]	dBm
Blocking offset	[2025<f<2050] [2230<f<2255]	[f<2025 f>2255]	MHz

5.5.5 Test Requirements

The measured BER, derived in step (2), shall not exceed 0.001.

5.6 Spurious Response

5.6.1 Definition and applicability

Spurious response is a measure of the receiver's ability to receive a wanted signal on its assigned channel frequency without exceeding a given degradation due to the presence of an unwanted CW interfering signal at any other frequency at which a response is obtained i.e. for which the blocking limit is not met.

The requirements and this test apply to all types of UTRA for the MS.

5.6.2 Conformance requirements

The BER shall not exceed 0.001 for the parameters specified in Table 5.6.1 and Table 5.6.2.

5.6.3 The reference for this requirement is 25.101 §7.7. Test purpose

To verify that the MS BER does not exceed 0.001 for the parameters specified in Table 5.6.11 and Table 5.6.2.

5.6.4 Method of test

5.6.4.1 Initial conditions

- (1) Connect the SS to the MS antenna connector as shown in Figure A.6.
- (2) A call is set up according to the Generic call setup procedure using parameters as specified in Table 5.6.1.
- (3) Enter the MS into loopback test mode and start the loopback test.

See [3] iTS-T1.001 Logical Test Interface for details regarding generic call setup procedure and loopback test.

<Editor's Note: The generic call setup procedure is currently specified in Annex A of iTS-T1.001.>

Table 5.6.1 Test parameters for Spurious Response

Parameter	Level	Unit
$\frac{\text{PCCPCH_Ec}}{I_{\text{or}}}$	[-1]	dB
$\frac{\text{DPCH_Ec}}{I_{\text{or}}}$	[-7]	dB
\hat{I}_{or}	[-107]	dBm/4.096MHz
Forward Channel symbol rate	[32]	ksps
Reverse Channel bit rate	[64]	kbps
User bit rate	[12.2]	kbps

5.6.4.2 Procedure

- (1) Set the parameter of the CW generator as shown in Table 5.62.
- (2) Measure the BER of DCH received from the MS at the SS.

<Editor's Note> If the MS does not provide the data transmission rate combination that UL is equal or higher than DL, the BER in DL should be measured by the MS itself and the results should be reported to the SS through UL.

Table 5.6.2 Parameters of Spurious Signal

Parameter	Level	Unit
I _{blocking} (CW)	[-44]	dBm
fcw	Spurious response frequency	MHz

5.6.5 Test Requirements

The measured BER, derived in step (2), shall not exceed 0.001.

5.7 Intermodulation Characteristics

5.7.1 Definition and applicability

Third and higher order mixing of the two interfering RF signals can produce an interfering signal in the band of the desired channel. Intermodulation response rejection is a measure of the capability of the receiver to receive a wanted signal on its assigned channel frequency in the presence of two or more interfering signals which have a specific frequency relationship to the wanted signal.

The requirements and this test apply to all types of UTRA for the MS.

5.7.2 Conformance requirements

The BER shall not exceed 0.001 for the parameters specified in Table 5.7.1 and Table 5.7.2.

The reference for this requirement is 25.101 §7.8.

Note

- 1) Measurement channel is based on mapping of a 12.2 kbps voice channel

5.7.3 Test purpose

To verify that the MS BER does not exceed 0.001 for the parameters specified in Table 5.7.1 and Table 5.7.2.

5.7.4 Method of test

5.7.4.1 Initial conditions

- (1) Connect the SS to the MS antenna connector as shown in Figure A.7.
- (2) A call is set up according to the Generic call setup procedure using parameters as specified in Table 5.7.1.
- (3) Enter the MS into loopback test mode and start the loopback test.

See [3] iTS-T1.001 Logical Test Interface for details regarding generic call setup procedure and loopback test.

<Editor's Note: The generic call setup procedure is currently specified in Annex A of iTS-T1.001.>

Table 5.7.1 Test parameters for Intermodulation Characteristics

Parameter	Level	Unit
$\frac{\text{PCCPCH_Ec}}{I_{\text{or}}}$	[-1]	dB
$\frac{\text{DPCH_Ec}}{I_{\text{or}}}$	[-7]	dB
\hat{I}_{or}	[-107]	dBm/4.096MHz
Forward Channel symbol rate	[32]	ksps
Reverse Channel bit rate	[64]	kbps
User bit rate	[12.2]	kbps

TFCI	[On]	
------	------	--

5.7.4.2 Procedure

- (1) Set the parameters of the CW generator and interference signal generator as shown in Table 5.7.2.
- (2) Measure the BER of DCH received from the MS at the SS.

<Editor's Note> If the MS does not provide the data transmission rate combination that UL is equal or higher than DL, the BER in DL should be measured by the MS itself and the results should be reported to the SS through UL.

Table 5.7.2 Parameters of Interfering Signals

Parameter	Level	Unit
Tone Power	[-46]	dBm
Tone Offset from Receiving Carrier	[10]	MHz
I_{oc} (Interference Signal)	[-46]	dBm/4.096MHz
I_{oc} Offset from Receiving Carrier	[20]	MHz

5.7.5 Test Requirements

The measured BER, derived in step (1), shall not exceed 0.001.

5.8 Spurious Emissions

5.8.1 Definition and applicability

The spurious emissions power is the power of emissions generated or amplified in a receiver that appear at the MS antenna connector.

The requirements and this test apply to all types of UTRA for the MS.

<Editor's Note> Spurious emission is not clearly defined. (What conditions, operation mode, etc.)

5.8.2 Conformance requirements

The spurious emission shall be:

- (a) Less than -60dBm/4.096 MHz at the MS antenna connector, for frequencies within the MS receive band.
- (b) Less than -57dBm/100 kHz at the MS antenna connector, for frequencies band from 9kHz to 1GHz.
- (c) Less than -47dBm/100 kHz at the MS antenna connector, for frequencies band from 1GHz to 12.75 GHz.

The reference for this requirement is 25.101 §7.9.

5.8.3 Test purpose

To verify that the MS spurious emission meets the specifications described in clause 5.8.2.

5.8.4 Method of test

5.8.4.1 Initial conditions

- (1) Connect a spectrum analyzer (or other suitable test equipment) to the MS antenna connector as shown in Figure A.8.
- (2) Enable the MS receiver and set Cell Search Mode on a PCCPCH. Since there is no forward link signal, the MS should not pass the Cell Search mode.

<Editor's Note: The method to set Cell Search Mode should be defined.>

5.8.4.2 Procedure

- (1) Sweep the spectrum analyzer (or other suitable test equipment) over a frequency range from the lowest intermediate frequency or lowest oscillator frequency used in the receiver or 1 MHz, whichever is lowest to at least 3 times the carrier frequency.

5.8.5 Test Requirements

The all measured spurious emissions, derived in step (1), shall be:

- (a) Less than -60dBm/4.096 MHz at the MS antenna connector, for frequencies within the MS receive band.
- (b) Less than -57dBm/100 kHz at the MS antenna connector, for frequencies band from 9kHz to 1GHz.
- (c) Less than -47dBm/100 kHz at the MS antenna connector, for frequencies band from 1GHz to 12.75 GHz.

5.9 RSCP Detection Range and Accuracy

<Editor's Note> This specification may be defined by RAN4 in future???

5.9.1 Definition and applicability

[TBD]

5.9.2 Conformance requirements

[TBD]

5.9.3 Test purpose

[TBD]

5.9.4 Method of test

5.9.4.1 Initial conditions

- (1) Connect the SS to the MS antenna connector as shown in Figure A.3.
- (2) A call is set up according to the Generic call setup procedure using parameters as specified in Table 5.9.
- (3) Enter the MS into loopback test mode and start the loopback test.

See [3] iTS-T1.001 Logical Test Interface for details regarding generic call setup procedure and loopback test.

<Editor's Note: The generic call setup procedure is currently specified in Annex A of iTS-T1.001.>

Table 5.9 Test parameters for RSCP Detection Range and Accuracy

Parameter	Level / Status	Unit
\hat{I}_{or}	[-111 to -41]	dBm/4.096MHz
$\frac{Perch_Ec}{I_{or}}$	[-1]	dB
$\frac{DPCH_Ec}{I_{or}}$	[-7]	dB
Forward Channel symbol rate	[32]	ksps
Reverse Channel bit rate	[64]	kbps
User bit rate	[12.2]	kbps
TFCI	On	

5.9.4.2 Procedure

- (1) Select \hat{I}_{or} out of the range that is shown in Table 5.9.
- (2) Send the request message to the MS in order to get receiving RSCP value of the MS and then MS informs the RSCP value. Refer to iTS-T1.001 Logical Test Interface.
- (3) Repeat the above measurement several times. In this time, \hat{I}_{or} shall be varied over the range. [TBD]

5.9.5 Test Requirements

[TBD]

5.10 SIR Measurement Range and Accuracy

<Editor's Note> This test item is specified as "Closed loop power control in the downlink" in the referred document 25.101.

5.10.1 Definition and applicability

SIR measurement is the ability of the MS receiver to estimate the received SIR, compare it with the SIR target and transmit the TPC symbols in accordance to the results of this comparison.

The requirements and this test apply to all types of UTRA for the MS.

5.10.2 Conformance requirements

- (a) The accuracy for the SIR measurements shall be within the range shown in Table 5.10.1.
- (b) The range of the SIR measurement of the received signal in the downlink shall be better than shown in Table 5.10.1.

Table 5.10.1 SIR Measurement Range and Accuracy

SIR measurement accuracy	[] dB
SIR measurement range	[] dB

The reference for this requirement is 25.101 §6.4.2.1.

<Editor's Note> A time constant for SIR is specified in the referred document 25.101 as follows:

"The transmitted TPC symbols must respond to a change in the received SIR within the time period [0.625] ms".

5.10.3 Test purpose

To verify that the MS SIR measurement range and accuracy meets the specifications described in Table 5.10.1.

5.10.4 Method of test

5.10.4.1 Initial conditions

- (1) Connect the SS to the MS antenna connector as shown in Figure A.4.
- (2) A call is set up according to the Generic call setup procedure using parameters as specified in Table 5.10.2.
- (3) Enter the MS into loopback test mode and start the loopback test.

See [3] iTS-T1.001 Logical Test Interface for details regarding generic call setup procedure and loopback test.

<Editor's Note: The generic call setup procedure is currently specified in Annex A of iTS-T1.001.>

Table 5.10.2 Test parameters for SIR Measurement Range and Accuracy

Parameter	Level / Status	Unit
\hat{I}_{or}	[-69]	dBm/4.096MHz
$\frac{PCCPCH_Ec}{I_{or}}$	[-7]	dB
$\frac{DPCH_Ec}{I_{or}}$	[-1]	dB
Forward Channel symbol rate	[32]	ksps
Reverse Channel bit rate	[64]	kbps
User bit rate	[12.2]	kbps
TFCI	On	
I_{oc}	[] to []	dBm/4.096MHz

5.10.4.2 Procedure

- (1) Select I_{oc} out of the range that is shown in the table. [TBD]
- (2) Send the request message to the MS in order to get receiving SIR value of the MS and then MS informs the SIR value. Refer to iTS-T1.001 Logical Test Interface.
- (3) Repeat the above measurement several times. In this time, I_{oc} shall be varied over the range. [TBD]

5.10.5 Test Requirements

- (a) The accuracy for the SIR measurements, derived in step (2), shall not exceed the value in Table 5.10.1.
- (b) The range of the SIR measurement of the received signal in the downlink, derived in step (3), shall not less than the value in Table 5.10.1.

6 Performance requirements

<Editor's Note> This section is far from being completed.

6.1 General

6.1.1 Test Environments

MS is measured in different environments i.e., static, indoor, and outdoor to indoor and pedestrian, and vehicular environments. Each of these environments is modeled by typical channel models that are defined in Section 6.1.2.

MS shall be able to receive different channels transmitted from BS for it. These channels may have different bit rates and different BER/FER requirements. Table 6.1.1-1 describes shortly test environments.

Table 6.1.1-1 Test Environments for MS Performance Specifications

Test Services	Static	Indoor Office 3 km/h	Outdoor to Indoor and Pedestrian 3 km/h	Vehicular 120 km/h
	Information Data Rate, Performance metric	Information Data Rate, Performance metric	Information Data Rate, Performance metric	Information Data Rate, Performance metric
Paging Message	128 kbps MER 10^{-2}	-	-	-
FACH Message	128 kbps MER 10^{-2}	-	-	-
Speech	12.2 kbps BER 10^{-3}	12.2 kbps BER 10^{-3}	12.2 kbps BER 10^{-3}	12.2 kbps BER 10^{-3}
Circuit Switched Data	64, 384, 2048 kbps, BER 10^{-6}	64, 384 kbps BER 10^{-6}	64, 384 kbps BER 10^{-6}	64, 384 kbps BER 10^{-6}
Packet Switched Data	TBD	TBD	TBD	TBD

6.1.2 Channel Models

The channel model for the static performance measurement is an Additive White Gaussian Noise (AWGN) environment. No fading and multipaths exist.

Modified ITU channel models¹ are used for the performance measurements in multipath fading channels. The channel models for indoor, indoor to outdoor and pedestrian, and for vehicular environments are depicted in Table 6.1.2-1

¹ These channel models are the same that were used in simulations and evaluations of the system presented in "Japan's Proposal for Candidate Radio Transmission Technology on IMT-2000, W-CDMA, June 1998"

Table 6.1.2-1 Channel Models for Non-Static Environments

Indoor		Indoor to Outdoor and Pedestrian		Vehicular	
Relative Delay [ns]	Average Power [dB]	Relative Delay [ns]	Average Power [dB]	Relative Delay [ns]	Average Power [dB]
0	0.0	0	0.0	0	0.0
244	-9.6	244	-12.5	244	-2.4
488	-33.5	488	-24.7	488	-6.5
				732	-9.4
				976	-12.7
				1220	-13.3
				1708	-15.4
				1952	-25.4

6.1.3 CDMA Equations

The equations listed below describe the relationship between various parameters under different conditions.

6.1.3.1 BS or SS Transmission Power

Transmit power of the Base Station or Sistem Simulator is normalized to 1 and can be presented as

$$\frac{Perch_E_c}{I_{or}} + \frac{Pilot_E_c}{I_{or}} + \frac{TPC_E_c}{I_{or}} + \frac{RI_E_c}{I_{or}} + \frac{DATA_E_c}{I_{or}} + \frac{CPCH_E_c}{I_{or}} + \frac{OCNS_E_c}{I_{or}} = 1.$$

Dedicated Physical Channel consists of four different fields. Therefore, it can be shown that

$$\frac{DPCH_E_c}{I_{or}} = \frac{Pilot_E_c}{I_{or}} + \frac{TPC_E_c}{I_{or}} + \frac{RI_E_c}{I_{or}} + \frac{DATA_E_c}{I_{or}}.$$

Hence, transmit power of Base Station or SS can be presented also as

$$\frac{Perch_E_c}{I_{or}} + \frac{DPCH_E_c}{I_{or}} + \frac{CPCH_E_c}{I_{or}} + \frac{OCNS_E_c}{I_{or}} = 1.$$

6.1.3.2 Received Signal Strength for MS Not in Handoff (Static Channel)

For PCCPCH we get

$$Perch \frac{E_c}{I_o} = \frac{\frac{Perch_E_c}{I_{or}}}{\frac{I_{oc}}{\hat{I}_{or}} + 1}$$

and for a Dedicated Physical Channel

$$DPCH \frac{E_c}{I_o} = \frac{DPCH_E_c}{\frac{I_{or}}{\hat{I}_{or}} + 1}.$$

For the Common Physical Channel we get

$$CPCH \frac{E_c}{I_o} = \frac{CPCH_E_c}{\frac{I_{or}}{\hat{I}_{or}} + 1}.$$

E_b/N_t for the PCCPCH is given as

$$Perch \frac{E_b}{N_t} = \frac{Perch_E_c}{I_{or}} \times \frac{Chip Rate}{\frac{Information Data Rate}{\frac{I_{oc}}{\hat{I}_{or}}}}.$$

The same for Dedicated Traffic Channels is given as

$$DTCH \frac{E_b}{N_t} = \frac{DPCH_E_c}{I_{or}} \times \frac{Chip Rate}{\frac{Information Data Rate}{\frac{I_{oc}}{\hat{I}_{or}}}},$$

Similar equations can be derived for the Paging Channel and for the Forward Access Channel. For the Paging Channel we get

$$PCH \frac{E_b}{N_t} = \frac{CPCH_E_c}{I_{or}} \times \frac{Chip Rate}{\frac{Paging Data Rate}{\frac{I_{oc}}{\hat{I}_{or}}}},$$

and the same for FACH is given as

$$FACH \frac{E_b}{N_t} = \frac{CPCH_E_c}{I_{or}} \times \frac{Chip Rate}{\frac{Control Data Rate}{\frac{I_{oc}}{\hat{I}_{or}}}}.$$

6.1.3.3 Received Signal Strength for MS Not in Handoff (Non-Static Channel)

Let us assume that the sum of the channel tap powers is equal to one in multipath channel with L taps, i.e.,

$$\sum_{i=1}^L a_i^2 = 1,$$

where a_i represent the complex channel coefficient of the tap i . When assuming that a receiver combines all the multipaths E_b/N_t for PCCPCH is given as

$$\text{Perch} \frac{E_b}{N_t} = \frac{\text{Perch}_{-E_c}}{I_{or}} \times \frac{\text{Chip Rate}}{\text{Information Data Rate}} \times \sum_{i=1}^L \frac{a_i^2}{\frac{I_{oc}}{\hat{I}_{or}} + (1 - a_i^2)}.$$

As an example E_b/N_t for PCCPCH in Indoor channel is

$$\text{Perch} \frac{E_b}{N_t} = \frac{\text{Perch}_{-E_c}}{I_{or}} \times \frac{\text{Chip Rate}}{\text{Information Data Rate}} \times \left(\frac{0.900824}{\frac{I_{oc}}{\hat{I}_{or}} + 0.099176} + \frac{0.098773}{\frac{I_{oc}}{\hat{I}_{or}} + 0.901227} + \frac{0.000402}{\frac{I_{oc}}{\hat{I}_{or}} + 0.999598} \right).$$

Using the same assumptions, E_b/N_t for Dedicated Traffic Channels is given as

$$\text{DTCH} \frac{E_b}{N_t} = \frac{\text{DPCH}_{-E_c}}{I_{or}} \times \frac{\text{Chip Rate}}{\text{Information Data Rate}} \times \sum_{i=1}^L \frac{a_i^2}{\frac{I_{oc}}{\hat{I}_{or}} + (1 - a_i^2)}.$$

6.1.3.4 Received Signal Strength for MS in Two-Way Handover

When the received power from each cell is \hat{I}_{or} we get for each PCCPCH

$$\text{Perch} \frac{E_c}{I_o} = \frac{\frac{\text{Perch}_{-E_c}}{I_{or}}}{\frac{I_{oc}}{\hat{I}_{or}} + 2}.$$

If the power received from cell 1 and cell 2 are \hat{I}_{or1} and \hat{I}_{or2} , respectively, then

$$\text{Perch} \frac{E_c}{I_o} (\text{Cell 1}) = \frac{\frac{\text{Perch}_{-E_c}}{I_{or1}}}{\frac{I_{oc}}{\hat{I}_{or1}} + \frac{\hat{I}_{or2}}{\hat{I}_{or1}} + 1}$$

and

$$\text{Perch} \frac{E_c}{I_o} (\text{Cell 2}) = \frac{\frac{\text{Perch}_{-E_c}}{I_{or2}}}{\frac{I_{oc}}{\hat{I}_{or2}} + \frac{\hat{I}_{or1}}{\hat{I}_{or2}} + 1}.$$

Similarly,

$$DTCH \frac{E_b}{N_t} = \frac{DPCH - E_c}{I_{or}} \times \frac{\text{Chip Rate}}{\text{Information Data Rate}} \times \sum_{i=1}^L \frac{2a_i^2}{\frac{I_{oc}}{\hat{I}_{or}} + 1 + (1 - a_i^2)}$$

if the channel is non-static.

6.1.3.5 Measurement Configurations

In all measurements MS should transmit with maximum power while receiving signals from BS. Transmission Power Control is always disable during the measurements. Chip Rate is specified to be 4.096 MHz.

It is assumed that fields inside DPCH have the same energy per PN chip. Also, if the power of SCCPCH is not specified in the test parameter table, it should be set to zero. The power of OCNS should be adjusted that the power ratios (E_c/I_{or}) of all specified forward channels add up to one.

Measurement configurations for different scenarios are shown in Figure 6.1.3.5-1, Figure 6.1.3.5-2 and Figure 6.1.3.5-3.

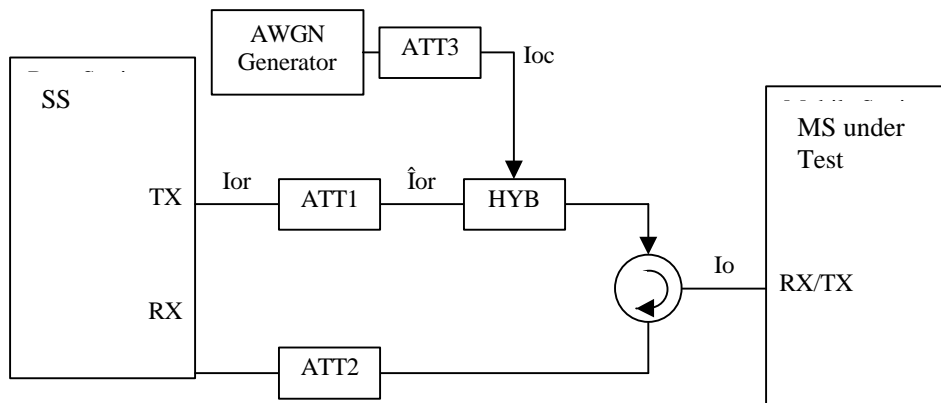

Figure 6.1.3.5-1. Measurement Configuration in Static Channel.

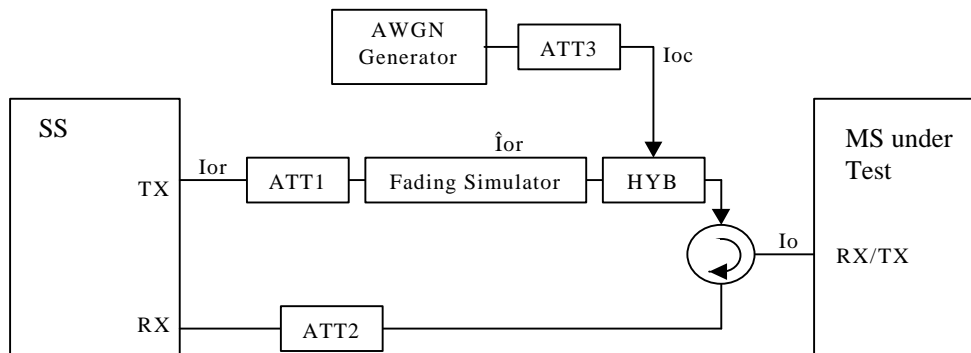

Figure 6.1.3.5-2. Measurement Configuration in Multipath Fading Channel.

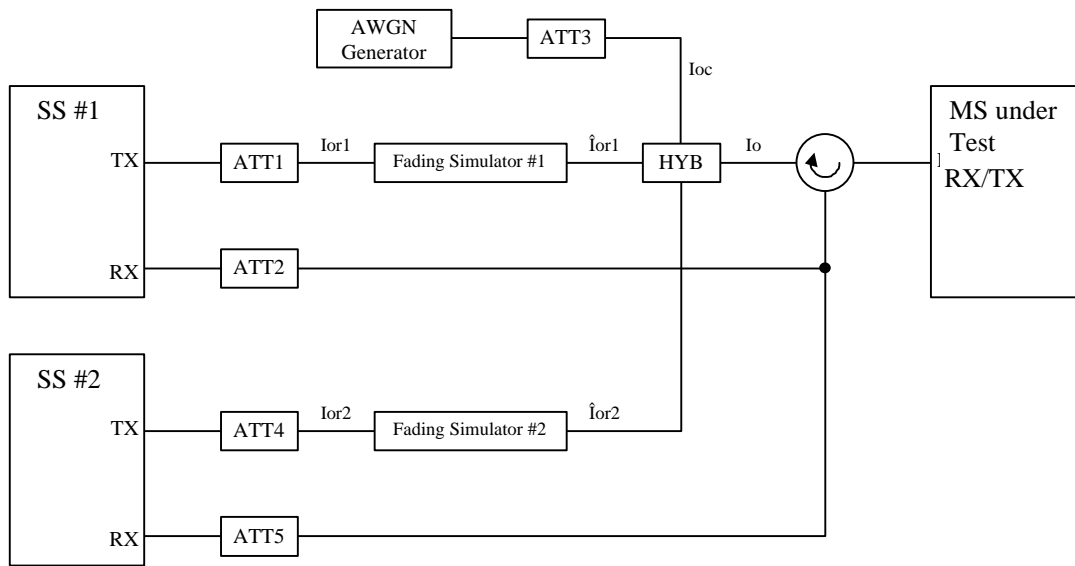

Figure 6.1.3.5-3. Measurement Configuration for Tests in Soft Handoff.

6.2 Demodulation in Static Channel

6.2.1 Demodulation of Paging Channel

6.2.1.1 Definition and applicability

The definition of this measure shall refer 3GPP S4.01A, Section 8.2.1.1 Demodulation of Paging Channel.

6.2.1.2 Test Conditions and Measurement Method

1. Connect the SS and an AWGN noise source to the MS antenna connector as shown in Figure 6.1.3.5-1.
2. Map the Paging Channel information into Common Physical Channel as specified in ARIB Volume 1.
3. Set the test parameters as specified in Table 6.2.1.2-1.
4. Send xx paging messages to MS.
5. Measure MER of received Paging messages.

Table 6.2.1.2-1. Test Parameters for Paging Channel Reception in an AWGN Channel.

Parameter	Unit	Value
$\frac{Perch_E_c}{I_{or}}$	dB	
$\frac{DPCH_E_c}{I_{or}}$	dB	
$\frac{CPCH_E_c}{I_{or}}$	dB	
\hat{I}_{or}/I_{oc}	dB	-1
I_{oc}	dBm/4.096 MHz	-60
Paging Data Rate	??	
$PCH E_b/N_t$	dB	

6.2.1.3 Test Requirements

6.2.2 Demodulation of Forward Access Channel

6.2.2.1 Definition and applicability

The definition of this measure shall refer 3GPP S4.01A, Section 8.2.2.2 Demodulation of Forward Access Channel.

6.2.2.2 Test Conditions and Measurement Method

1. Connect the SS and an AWGN noise source to the MS antenna connector as shown in Figure 6.1.3.5-1.
2. Map the Forward Access Channel information into Common Physical Channel as specified in ARIB Volume 1.
3. Set the test parameters as specified in Table 6.2.2.2-1.
4. Send xx FACH messages to MS.
5. Measure MER of received FACH messages

Table 6.2.2.2-1. Test Parameters for Forward Access Channel Reception in an AWGN Channel.

Parameter	Unit	Value
$\frac{Perch_E_c}{I_{or}}$	dB	
$\frac{DPCH_E_c}{I_{or}}$	dB	
$\frac{CPCH_E_c}{I_{or}}$	dB	
\hat{I}_{or}/I_{oc}	dB	-1
I_{oc}	dBm/4.096 MHz	-60
Control Data Rate	??	
FACH E_b/N_t	dB	

6.2.2.3 Test Requirements

6.2.3 Demodulation of Dedicated Traffic Channel

6.2.3.1 Definition and applicability

The definition of this measure shall refer 3GPP S4.01A, Section 8.2.2.3 Demodulation of Dedicated Traffic Channel.

6.2.3.2 Test Conditions and Measurement Method

1. Connect the SS and an AWGN noise source to the MS antenna connector as shown in Figure 6.1.3.5-1.
2. Set up the call.
3. Set the test parameters for test 1-8 as specified in Table 6.2.3.2-1 and Table 6.2.3.2-2.

4. Count, at the SS, the number of information bits transmitted and the number of correctly received information bits at the MS.
5. Measure BER of DCH channel.

Table 6.2.3.2-1. Test Parameters for Dedicated Traffic Channel Reception in an AWGN Channel.

Parameter	Unit	Test 1	Test 2	Test 3	Test 4
$\frac{Perch_E_c}{I_{or}}$	dB				
$\frac{DPCH_E_c}{I_{or}}$	dB				
\hat{I}_{or}/I_{oc}	dB	-1			
I_{oc}	dBm/4.096 MHz	-60			
Information Data Rate	kbps	12.2	12.2	64	64
Channel Symbol Rate	ksps	32	32	128	128
Rate Information	-	off	on	off	on
DTCH E_b/N_t	dB				

Table 6.2.3.2-2. Test Parameters for Dedicated Traffic Channel Reception in an AWGN Channel.

Parameter	Unit	Test 5	Test 6	Test 7	Test 8
$\frac{Perch_E_c}{I_{or}}$	dB				
$\frac{DPCH_E_c}{I_{or}}$	dB				
\hat{I}_{or}/I_{oc}	dB	-1			
I_{oc}	dBm/4.096 MHz	-60			
Information Data Rate	kbps	384	384	2048	2046
Channel Symbol Rate	ksps	512	512	3*1024 ²	3*1024
Rate Information	-	off	on	off	on
DTCH E_b/N_t	dB				

6.2.3.3 Test Requirements

² Multicode transmission with 3 different codes each having 1024 ksps channel symbol rate.

6.3 Demodulation of Dedicated Traffic Channel in Multipath Fading Channel

6.3.1 Single Link Performance

6.3.1.1 Definition and applicability

The definition of this measure shall refer 3GPP S4.01A, Section 8.3.1 Single Link Performance.

6.3.1.2 Test Conditions and Measurement Method

1. Connect the SS, multipath fading simulator and an AWGN noise source to the MS antenna connector as shown in Figure 6.1.3.5-2.
2. Set up the call.
3. Set the test parameters for test 1-20 as specified Table 6.3.1.2-1 to Table 6.3.1.2-4.
4. Count, at the SS, the number of information bits transmitted and the number of correctly received information bits at the MS.
5. Measure BER of DCH channel.

Table 6.3.1.2-1. Test Parameters for Dedicated Traffic Channel Reception in a Multipath Channel (Indoor Environment).

Parameter	Unit	Test 1	Test 2	Test 3	Test 4
$\frac{Perch_E_c}{I_{or}}$	dB				
$\frac{DPCH_E_c}{I_{or}}$	dB				
\hat{I}_{or}/I_{oc}	dB	5?			
I_{oc}	dBm/4.096 MHz	-60			
Information Data Rate	kbps	12.2	12.2	64	64
Channel Symbol Rate	ksps	32	32	128	128
Rate Information	-	off	on	off	on
DTCH E_b/N_t	dB				

Table 6.3.1.2-2. Test Parameters for Dedicated Traffic Channel Reception in a Multipath Channel (Indoor Environment).

Parameter	Unit	Test 5	Test 6	Test 7	Test 8
$\frac{Perch_E_c}{I_{or}}$	dB				
$\frac{DPCH_E_c}{I_{or}}$	dB				
\hat{I}_{or}/I_{oc}	dB	5?			
I_{oc}	dBm/4.096 MHz	-60			
Information Data Rate	kbps	384	384	2048	2048
Channel Symbol Rate	ksps	512	512	3*1024	3*1024
Rate Information	-	off	on	off	on
DTCH E_b/N_t	dB				

Table 6.3.1.2-3. Test Parameters for Dedicated Traffic Channel Reception in a Multipath Channel (Indoor to Outdoor and Pedestrian Environment).

Parameter	Unit	Test 9	Test 10	Test 11	Test 12	Test 13	Test 14
$\frac{Perch_E_c}{I_{or}}$	dB						
$\frac{DPCH_E_c}{I_{or}}$	dB						
\hat{I}_{or}/I_{oc}	dB	5?					
I_{oc}	dBm/4.096 MHz	-60					
Information Data Rate	kbps	12.2	12.2	64	64	384	384
Channel Symbol Rate	ksps	32	32	128	128	512	512
Rate Information	-	off	on	off	on	off	on
DTCH E_b/N_t	dB						

Table 6.3.1.2-4. Test Parameters for Dedicated Traffic Channel Reception in a Multipath Channel (Vehicular Environment).

Parameter	Unit	Test 15	Test 16	Test 17	Test 18	Test 19	Test 20
$\frac{Perch_E_c}{I_{or}}$	dB						
$\frac{DPCH_E_c}{I_{or}}$	dB						
\hat{I}_{or}/I_{oc}	dB	5?					
I_{oc}	dBm/4.096 MHz	-60					
Information Data Rate	kbps	12.2	12.2	64	64	384	384
Channel Symbol Rate	ksps	32	32	128	128	512	512
Rate Information	-	off	on	off	on	off	on
DTCH E_b/N_t	dB						

6.3.1.3 Test Requirements

6.3.2 Inter-Cell Soft Handover Performance

6.3.2.1 Definition and applicability

The definition of this measure shall refer 3GPP S4.01A, Section 8.4 Inter-Cell Soft Handover Performance.

6.3.2.2 Test Conditions and Measurement Method

1. Connect the SS, multipath fading simulator and an AWGN noise source to the MS antenna connector as shown in Figure 6.1.3.5-3.
2. Set up the call.
3. Set the test parameters for test 1-6 as specified in Table 6.3.2.2-1.
4. Count, at the SS, the number of information bits transmitted and the number of correctly received information bits at the MS.
5. Measure BER of DCH channel.

Table 6.3.2.2-1. Test Parameters for Dedicated Traffic Channel Reception in a Multipath Channel during a Soft Handoff (Vehicular Environment).

Parameter	Unit	Test 1	Test 2	Test 3	Test 4	Test 5	Test 6
$\frac{Perch_E_c}{I_{or}}$	dB						
$\frac{DPCH_E_c}{I_{or}}$	dB						
\hat{I}_{or1}/I_{oc} and \hat{I}_{or2}/I_{oc}	dB	5?					
I_{oc}	dBm/4.096 MHz	-60					
Information Data Rate	kbps	12.2	12.2	64	64	384	384
Channel Symbol Rate	ksps	32	32	128	128	512	512
Rate Information	-	off	on	off	on	off	on
DTCH E_b/N_t	dB						

6.3.2.3 Test Requirements

6.4 Synchronization Performance

6.4.1 Search of other Cells

6.4.1.1 Definition and applicability

The definition of this measure shall refer 3GPP S4.01A, Section 8.5.1.1 Search of other Cells.

6.4.1.2 Test Conditions and Measurement Method

Table 6.4.1.2-1. Test Parameters for the Search of other Cells.

Parameter	Unit	Channel 1		Channel 2	
		Time 1	Time 2	Time 1	Time 2
$\text{Perch } \frac{E_c}{I_{or}}$	dB				
\hat{I}_{or}/I_{oc}	dB				
I_{oc}	dBm/4.096 MHz	-60			
$\text{Perch } \frac{E_c}{I_o}$	dB				

1. Setup the equipment as shown in Figure 6.1.3.5-3 (without fading channel blocks)
2. Set the test parameters as specified in Table 6.4.1.2-1.
3. Turn MS on.
4. TBD

6.4.1.3 Test Requirements

6.4.2 Inter-Frequency Handover

6.4.2.1 Definition and applicability

The definition of this measure shall refer 3GPP S4.01A, Section 8.5.2 Inter-Frequency Handover.

6.4.2.2 *Test Conditions and Measurement Method*

TBD

6.4.2.3 *Test Requirements*

6.5 Timing requirements

6.5.1 Synchronization

6.5.1.1 Definition and applicability

The definition of this measure shall refer 3GPP S4.01A, Section 8.6.1 Synchronization.

6.5.1.2 Test Conditions and Measurement Method

The measuring configuration is shown in Figure 6.1.3.5-1.

6.5.1.3 Test Requirements

6.5.2 Channel Timing Dependencies

6.5.2.1 Definition and applicability

The definition of this measure shall refer 3GPP S4.01A, Section 8.6.2 Channel Timing Dependencies.

6.5.2.2 Test Conditions and Measurement Method

TBD

6.5.2.3 Test Requirements

6.5.3 Reception Timing

6.5.3.1 Definition and applicability

The definition of this measure shall refer 3GPP S4.01A, Section 8.6.3 Reception Timing.

6.5.3.2 *Test Conditions and Measurement Method*

The measuring configuration is shown in Figure 6.1.3.5-1.

6.5.3.3 *Test Requirements*

7 *Requirement of Test Equipment*

[TBD]

Annex.1 Connection Diagrams

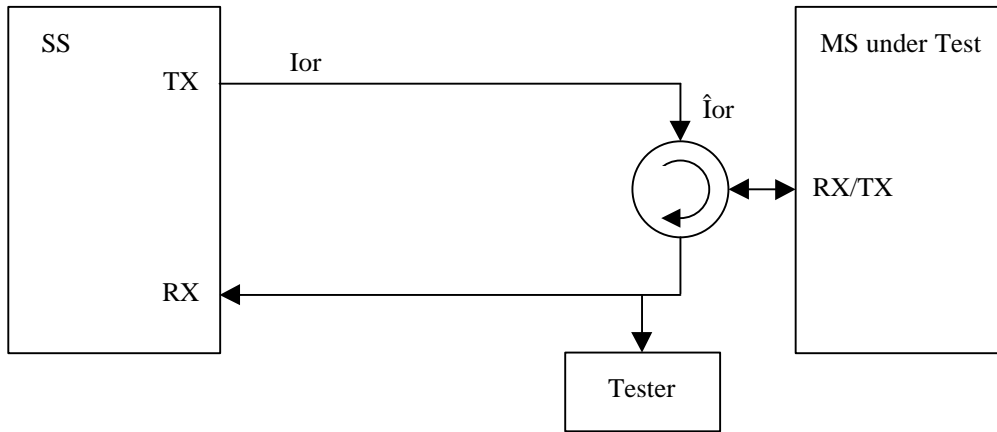

Figure A.1 Connection for Basic TX Test

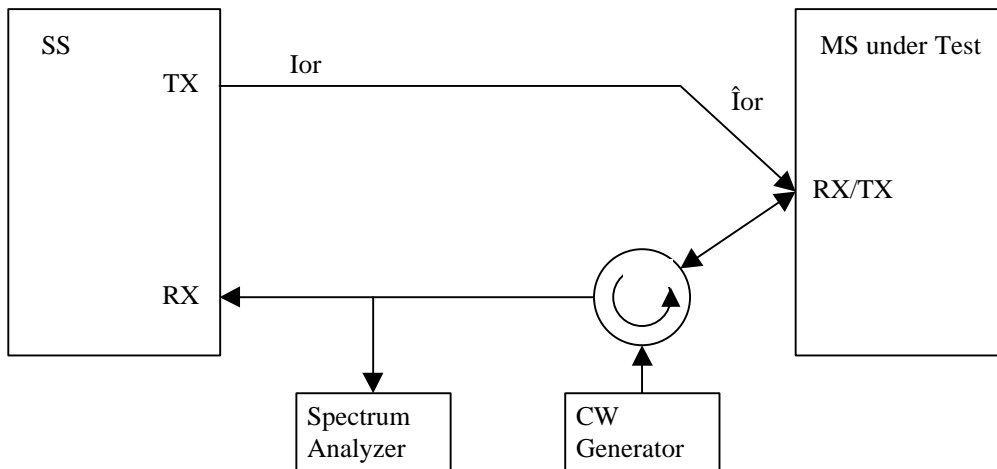

Figure A.2 Connection for TX Intermodulation Test

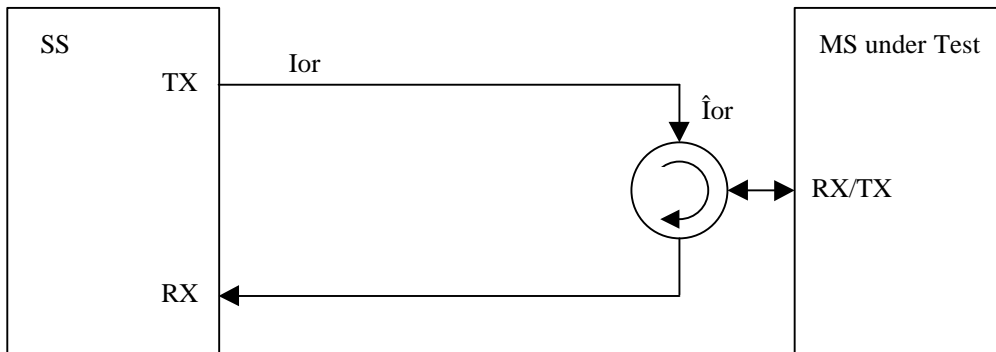

Figure A.3 Connection for Basic RX Test

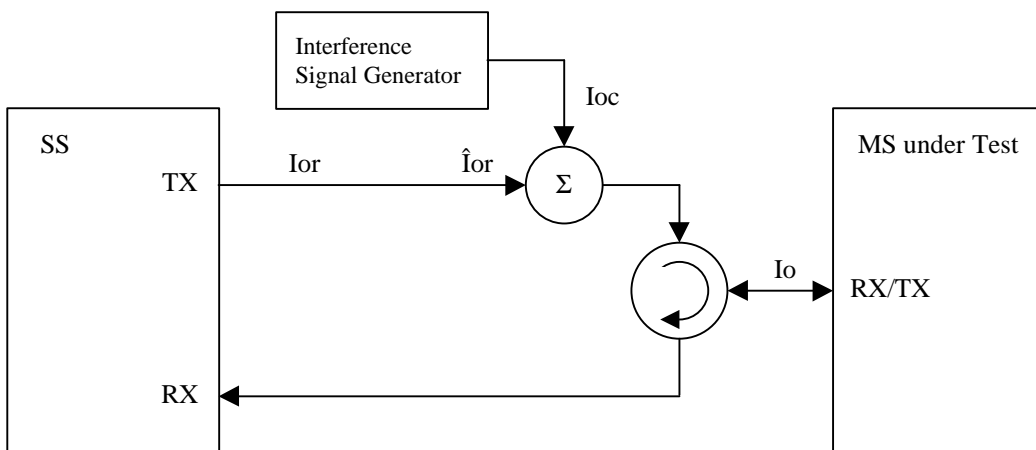

Figure A.3 Connection for RX Test with Interference

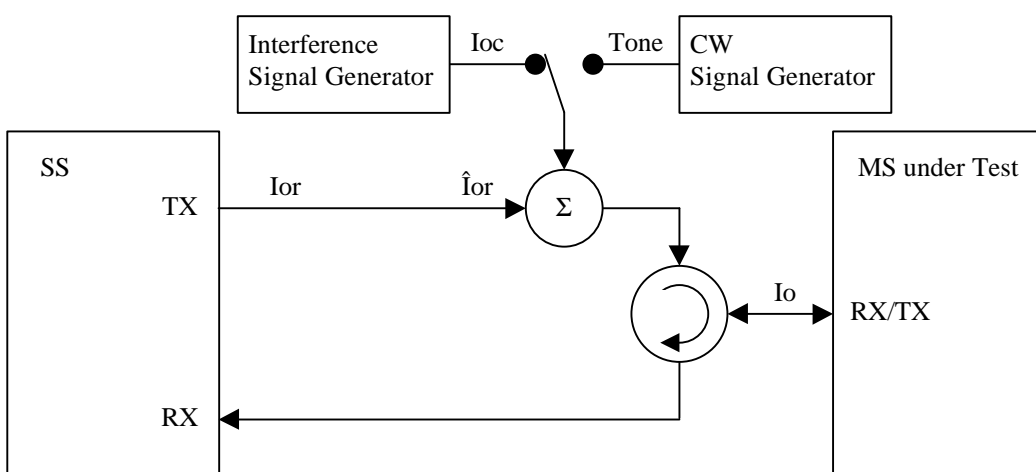

Figure A.5 Connection for RX Test with Interference or additional CW

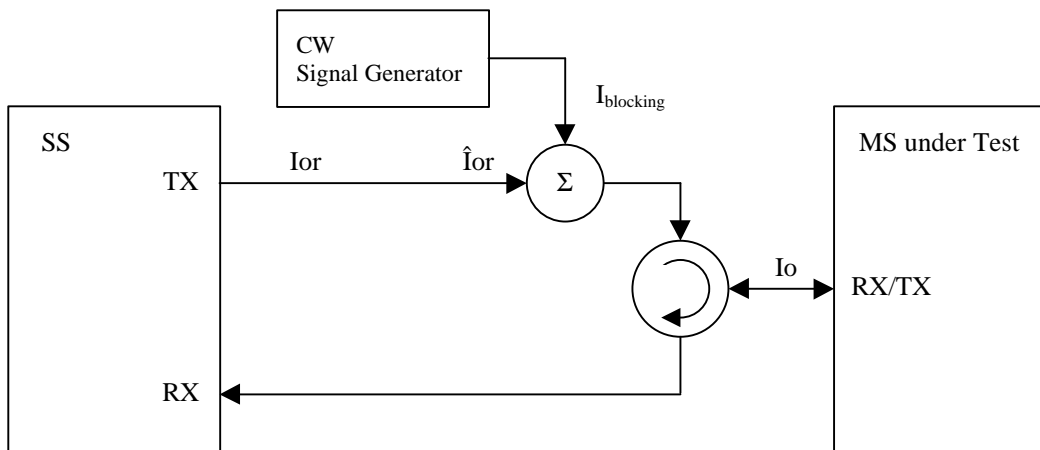

Figure A.6 Connection for RX Test with additional CW

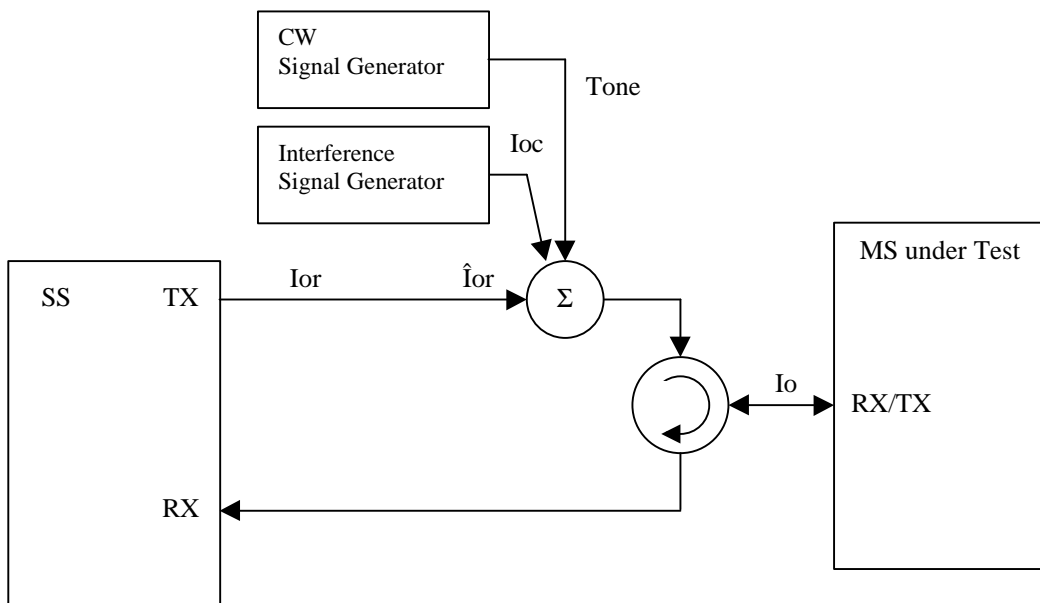

Figure A.7 Connection for RX Test with both Interference and additional CW

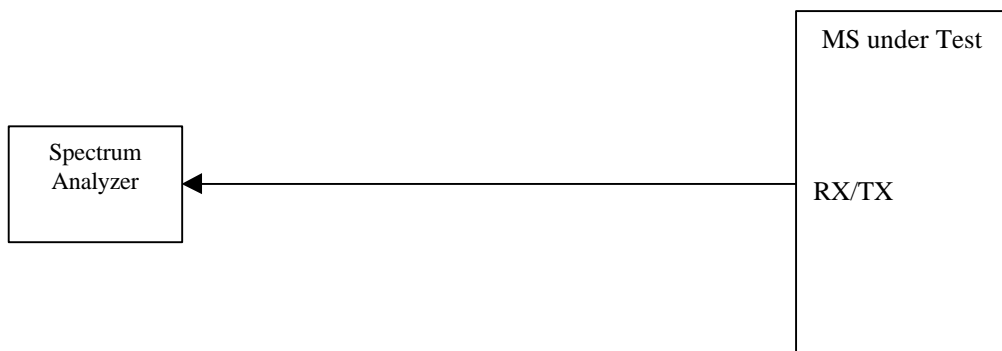

Figure A.8 Connection for Spurious Emission Test

Bibliography

The following material, though not specifically referenced in the body of the present document (or not publicly available), gives supporting information.

- <Publication>: "<Title>".

History

Document history		
version	date (yyyy-mm-dd)	comments
V0.0.0	1999-02-xx	Initial document. The contents are given from ARIB "Specification of Mobile Station for 3G Mobile System" (Ver.1.0-1.0)
V0.0.1	1999-03-26	Revised according to the results of TSG-T WG1 RF-Subgroup meeting #1 (March 10-11, 1999 Tokyo)
V1.0.0	1999-04-13	Revised from Tdoc T1R(99)022 according to the results of TSG-T WG1 RF-Subgroup meeting #2 (April 1-2, 1999 Tokyo)
V0.1.1	1999-05-14	The document numbering was changed from TS XX.XX to iTS-T1.003. The contents are revised from Tdoc T1-99040 according to the results of TSG-T1 meeting #2 and TSG-T1/RF-SWG meeting #3 (April 13-15, 1999 Paris)
V0.2.0	1999-06-14	Revised from Tdoc T1R(99)034 according to the results of TSG-T WG1 RF-Subgroup meeting #4 (May 14, 1999 Stockholm)
V1.0.0	1999-06-17	Proposal V1 to T1 Plenary
Editors for Measurement Procedures (FDD) <Editor's name> Kenji Higuchi <Editor's Company> ADVANTEST Corporation <Editor's Information> This document is written in Microsoft® Word 97.		