

3GPP TSG-SA3 Meeting #33
 Beijing, China, 10-14 May 2004

Tdoc # S3-040440

CR-Form-v7
CHANGE REQUEST
⌘ 33.234 CR CRNum ⌘ rev - ⌘ Current version: 6.0.0 ⌘

For **HELP** on using this form, see bottom of this page or look at the pop-up text over the ⌘ symbols.

Proposed change affects: UICC apps ME Radio Access Network Core Network

Title:	⌘ WLAN mechanism to allow restrictions on simultaneous sessions		
Source:	⌘ Nokia		
Work item code:	⌘ WLAN-3G interworking security	Date:	⌘ 14/05/2004
Category:	⌘ C	Release:	⌘ Rel-6
	Use <u>one</u> of the following categories:		Use <u>one</u> of the following releases:
	F (correction)		2 (GSM Phase 2)
	A (corresponds to a correction in an earlier release)		R96 (Release 1996)
	B (addition of feature),		R97 (Release 1997)
	C (functional modification of feature)		R98 (Release 1998)
	D (editorial modification)		R99 (Release 1999)
	Detailed explanations of the above categories can be found in 3GPP TR 21.900 .		Rel-4 (Release 4)
			Rel-5 (Release 5)
			Rel-6 (Release 6)

Reason for change:	⌘ If the WLAN-UE connects to multiple AAA servers, there is no need to keep the previous connection for a genuine UE. The release mechanism can also mitigate any malicious mis-use of the credential to minimum.
Summary of change:	⌘ The change is added how to handle multiple registrations of the WLAN-UE based on local policy defined for AAA server and HSS/HLR.
Consequences if not approved:	⌘ The malicious usage of radio service will not be prevented.

Clauses affected:	⌘ 6.1.1.1, 6.1.2.1										
Other specs affected:	<table border="1" style="display: inline-table; border-collapse: collapse;"> <tr> <td style="width: 20px; text-align: center;">Y</td> <td style="width: 20px; text-align: center;">N</td> </tr> <tr> <td style="text-align: center;">X</td> <td style="text-align: center;"></td> </tr> <tr> <td style="text-align: center;"></td> <td style="text-align: center;">X</td> </tr> <tr> <td style="text-align: center;"></td> <td style="text-align: center;">X</td> </tr> </table> Other core specifications	Y	N	X			X		X	⌘ 24.234	
Y	N										
X											
	X										
	X										
Other comments:	⌘										

6.1.1 USIM-based WLAN Access Authentication

USIM based authentication is a proven solution that satisfies the authentication requirements from section 4.2. This form of authentication shall be based on EAP-AKA (ref. [4]), as described in section 6.1.1.1.

Editor's note: also see section 4.2.4 on WLAN-UE Functional Split.

6.1.1.1 EAP/AKA Procedure

The EAP-AKA authentication mechanism is specified in ref. [4]. The present section describes how this mechanism is used in the WLAN-3GPP interworking scenario.

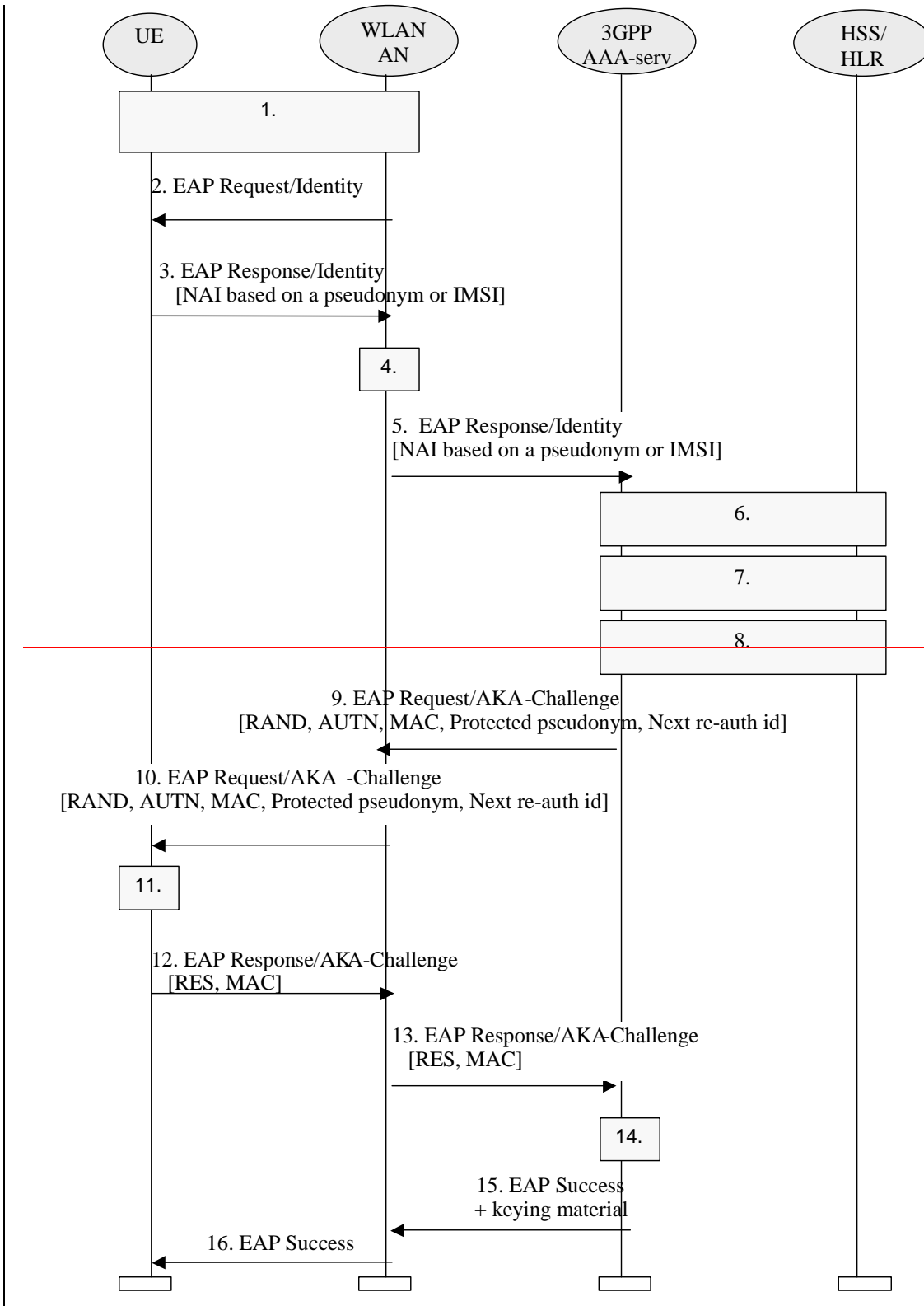

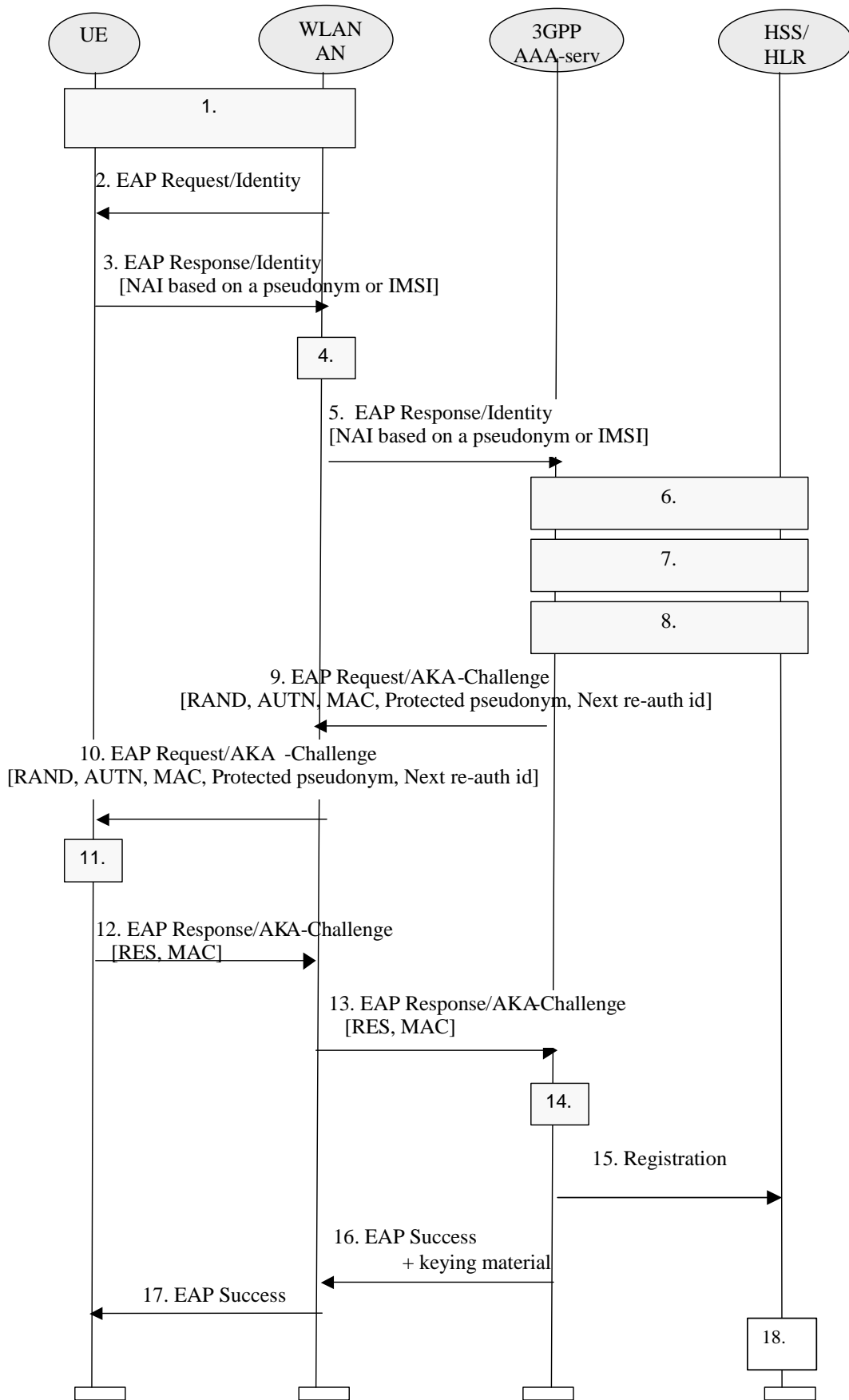

Figure 4: Authentication based on EAP AKA scheme

1. A connection is established between the WLAN-UE and the WLAN-AN, using a Wireless LAN technology specific procedure (out of scope for this specification).
2. The WLAN-AN sends an EAP Request/Identity to the WLAN-UE.

EAP packets are transported over the Wireless LAN interface encapsulated within a Wireless LAN technology specific protocol.

3. The WLAN-UE sends an EAP Response/Identity message. The WLAN-UE sends its identity complying with Network Access Identifier (NAI) format specified in RFC 2486. NAI contains either a temporary identifier (pseudonym) allocated to the WLAN-UE in previous authentication or, in the case of first authentication, the IMSI.

NOTE 1: Generating an identity conforming to NAI format from IMSI is defined in EAP/AKA [4].

4. The message is routed towards the proper 3GPP AAA Server based on the realm part of the NAI. The routing path may include one or several AAA proxies (not shown in the figure).

NOTE 2: Diameter referral can also be applied to find the AAA server.

5. The 3GPP AAA server receives the EAP Response/Identity packet that contains the subscriber identity. [The identifier of the WLAN radio network, VPLMN Identity and the MAC address of the WLAN-UE shall also be received by the 3GPP AAA server in the same message.](#)
6. 3GPP AAA Server identifies the subscriber as a candidate for authentication with EAP-AKA, based on the received identity. The 3GPP AAA Server then checks that it has an unused authentication vector available for that subscriber. If not, a set of new authentication vectors is retrieved from HSS/HLR. A mapping from the temporary identifier to the IMSI may be required.

NOTE 3: It could also be the case that the 3GPP AAA Server first obtains an unused authentication vector for the subscriber and, based on the type of authenticator vector received (i.e. if a UMTS authentication vector is received), it regards the subscriber as a candidate for authentication with EAP-AKA.

7. 3GPP AAA server checks that it has the WLAN access profile of the subscriber available. If not, the profile is retrieved from HSS. 3GPP AAA Server verifies that the subscriber is authorized to use the WLAN service.

Although this step is presented after step 6 in this example, it could be performed at some other point, however before step 14. (This will be specified as part of the Wx interface.)

8. New keying material is derived from IK and CK., cf. [4]. This keying material is required by EAP-AKA, and some extra keying material may also be generated for WLAN technology specific confidentiality and/or integrity protection.

A new pseudonym may be chosen and protected (i.e. encrypted and integrity protected) using EAP-AKA generated keying material.

9. 3GPP AAA Server sends RAND, AUTN, a message authentication code (MAC) and two user identities (if they are generated): protected pseudonym and/or re-authentication id to WLAN-AN in EAP Request/AKA-Challenge message. The sending of the re-authentication id depends on 3GPP operator's policies on whether to allow fast re-authentication processes or not. It implies that, at any time, the AAA server decides (based on policies set by the operator) to include the re-authentication id or not, thus allowing or disallowing the triggering of the fast re-authentication process.

10. The WLAN-AN sends the EAP Request/AKA-Challenge message to the WLAN-UE.

11. The WLAN-UE runs UMTS algorithm on the USIM. The USIM verifies that AUTN is correct and hereby authenticates the network. If AUTN is incorrect, the terminal rejects the authentication (not shown in this example). If the sequence number is out of synch, terminal initiates a synchronization procedure, c.f. [4]. If AUTN is correct, the USIM computes RES, IK and CK.

The WLAN UE derives required additional new keying material from the new computed IK and CK from the USIM, checks the received MAC with the new derived keying material.

If a protected pseudonym was received, then the WLAN-UE stores the pseudonym for future authentications.

12. The WLAN UE calculates a new MAC value covering the EAP message with the new keying material. WLAN-UE sends EAP Response/AKA-Challenge containing calculated RES and the new calculated MAC value to WLAN-AN.

13. WLAN-AN sends the EAP Response/AKA-Challenge packet to 3GPP AAA Server

14. 3GPP AAA Server checks the received MAC and compares XRES to the received RES. [If successful, the AAA server shall compare the MAC address, VPLMN Identity and the WLAN radio network information of the authentication exchange with the same information of the ongoing sessions. If the information is the same as with an ongoing session, then the authentication exchange is related to the ongoing session, so there is no need to do anything for the old sessions \(skip step 15\).](#)

15. [Otherwise, the AAA server considers that the authentication exchange is related to a new scenario-2 session. In this case the AAA server shall contact ~~register to~~ the HSS for a decision. The AAA server shall ~~also inform to~~ the HSS of the WLAN-UE's MAC address, the VPLMN Identity, as well as the identifier of the WLAN radio network used.](#)

16. [If all checks in step 14 are successful, then 3GPP AAA Server sends the EAP Success message to WLAN-AN. If some extra keying material was generated for WLAN technology specific confidentiality and/or integrity protection then the 3GPP AAA Server includes this keying material in the underlying AAA protocol message \(i.e. not at EAP level\). The WLAN-AN stores the keying material to be used in communication with the authenticated WLAN-UE.](#)

~~16.17.~~ WLAN-AN informs the WLAN-UE about the successful authentication with the EAP Success message. Now the EAP AKA exchange has been successfully completed, and the WLAN-UE and the WLAN-AN share keying material derived during that exchange.

18. [If the same subscriber but different MAC address, or VPLMN identity or the radio network information is received than in any ongoing session, then the registration is related to a new scenario-2 session. The HSS shall close an old scenario-2 session by indicating to the 3GPP AAA server of the old session to terminate the session, based on the policy whether simultaneous sessions are not allowed, or whether the number of allowed sessions has been exceeded.](#)

6.1.2 GSM SIM based WLAN Access authentication

SIM based authentication is useful for GSM subscribers that do not have a UICC with a USIM application. This form of authentication shall be based on EAP-SIM (ref. [5]), as described in section 6.1.2.1. This authentication method satisfies the authentication requirements from section 4.2, without the need for a UICC with a USIM application

Editor's note: Also see section 4.2.4 on WLAN UE split.

6.1.2.1 EAP SIM procedure

The EAP-SIM authentication mechanism is specified in ref. [5]. The present section describes how this mechanism is used in the WLAN-3GPP interworking scenario.

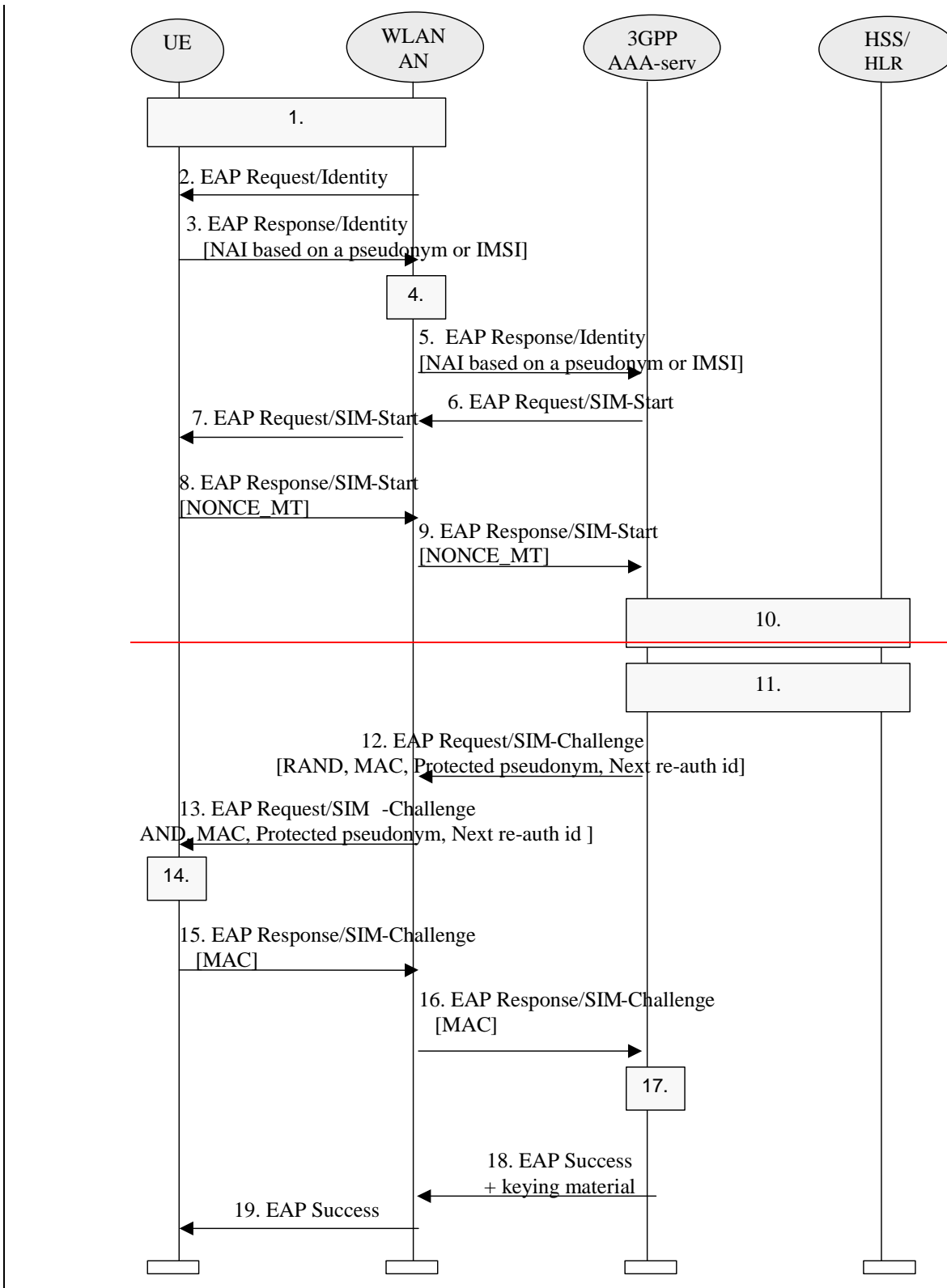

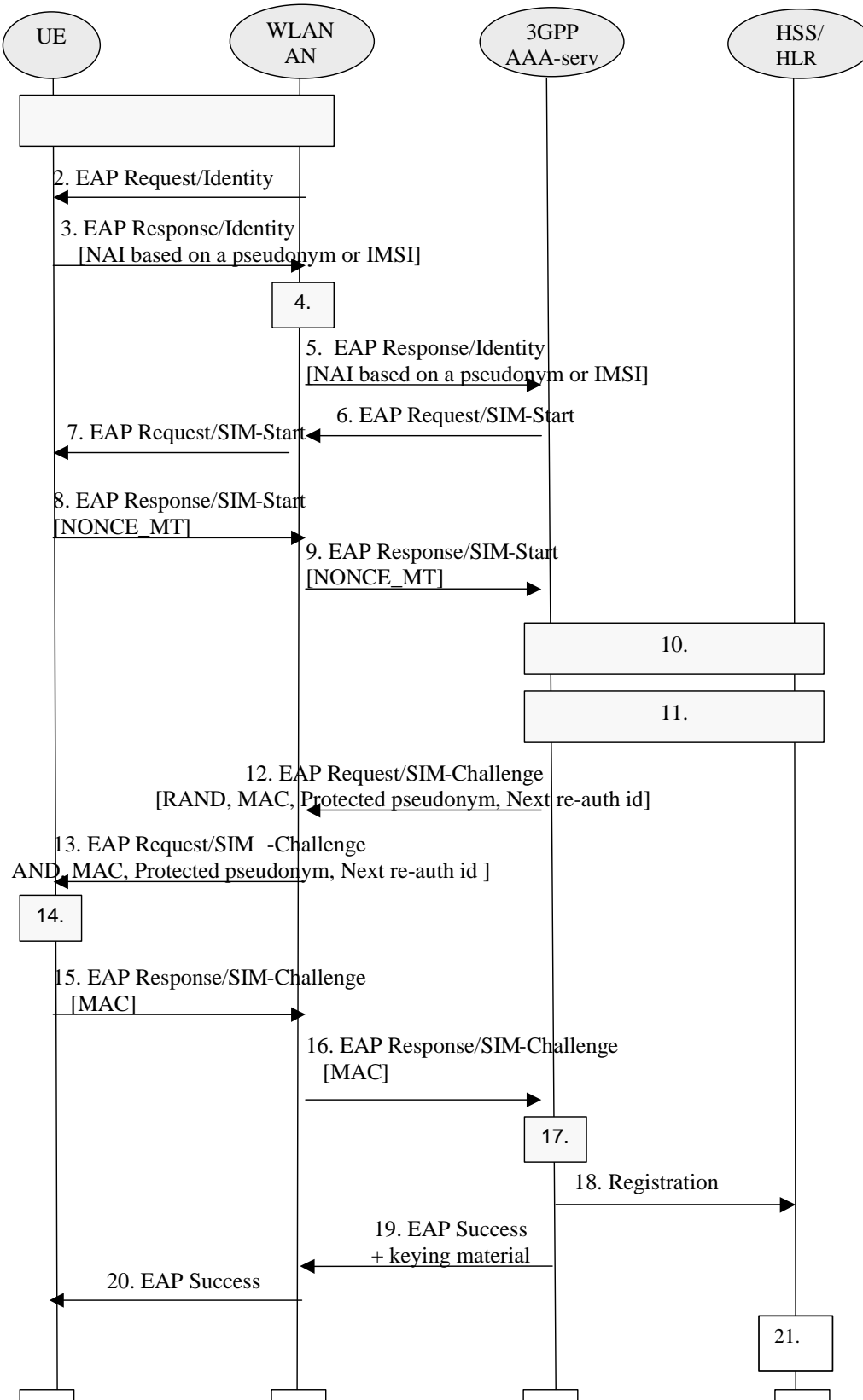

Figure 5: Authentication based on EAP SIM scheme

1. A connection is established between the WLAN-UE and the WLAN-AN, using a Wireless LAN technology specific procedure (out of scope for this specification).
2. The WLA-AN sends an EAP Request/Identity to the WLAN-UE.

EAP packets are transported over the Wireless LAN interface encapsulated within a Wireless LAN technology specific protocol.

3. The WLAN-UE sends an EAP Response/Identity message. The WLAN-UE sends its identity complying with the Network Access Identifier (NAI) format specified in RFC 2486. NAI contains either a temporary identifier (pseudonym) allocated to WLAN-UE in previous authentication or, in the case of first authentication, the IMSI.

NOTE 1: Generating an identity conforming to NAI format from IMSI is defined in EAP/SIM.

4. The message is routed towards the proper 3GPP AAA Server based on the realm part of the NAI. The routing path may include one or several AAA proxies (not shown in the figure).

NOTE 2: Diameter referral can also be applied to find the AAA server.

5. The 3GPP AAA server receives the EAP Response/Identity packet that contains the subscriber identity. [The identifier of the WLAN radio network, VPLMN Identity and the MAC address of the WLAN-UE shall also be received by the 3GPP AAA server in the same message.](#)

6. The 3GPP AAA Server, identifies the subscriber as a candidate for authentication with EAP-SIM, based on the received identity, and then it sends the EAP Request/SIM-Start packet to WLAN-AN.

NOTE 3: It could also be the case that the 3GPP AAA Server first obtains an authentication vector for the subscriber and, based on the type of authenticator vector received (i.e. if a GSM authentication vector is received), it regards the subscriber as a candidate for authentication with EAP-SIM.

7. WLAN-AN sends the EAP Request/SIM-Start packet to WLAN-UE
8. The WLAN-UE chooses a fresh random number NONCE_MT. The random number is used in network authentication.

The WLAN-UE sends the EAP Response/SIM-Start packet, containing NONCE_MT, to WLAN-AN.

9. WLAN-AN sends the EAP Response/SIM-Start packet to 3GPP AAA Server

10. The AAA server checks that it has available N unused authentication vectors for the subscriber. Several GSM authentication vectors are required in order to generate keying material with effective length equivalent to EAP-AKA. If N authentication vectors are not available, a set of authentication vectors is retrieved from HSS/HLR. A mapping from the temporary identifier to the IMSI may be required.

Although this step is presented after step 9 in this examples, it could be performed at some other point, for example after step 5, however before step 12. (This will be specified as part of the Wx interface.)

11. The AAA server checks that it has the WLAN access profile of the subscriber available. If not, the profile is retrieved from HSS/HLR. 3GPP AAA Server verifies that the subscriber is authorized to use the WLAN service.

Although this step is presented after step 10 in this example, it could performed at some other point, however before step 18. (This will be the specified as part of the Wx interface).

12. New keying material is derived from NONCE_MT and N Kc keys. This keying material is required by EAP-SIM, and some extra keying material may also be generated for WLAN technology specific confidentiality and/or integrity protection.

A new pseudonym and/or a re-authentication identity may be chosen and protected (i.e. encrypted and integrity protected) using EAP-SIM generated keying material.

A message authentication code (MAC) is calculated over the EAP message using an EAP-SIM derived key. This MAC is used as a network authentication value.

3GPP AAA Server sends RAND, MAC, protected pseudonym and re-authentication identity (the two latter in case they were generated) to WLAN-AN in EAP Request/SIM-Challenge message. The sending of the re-authentication id depends on 3GPP operator's policies on whether to allow fast re-authentication processes or

not. It implies that, at any time, the AAA server decides (based on policies set by the operator) to include the re-authentication id or not, thus allowing or disallowing the triggering of the fast re-authentication process.

13. The WLAN sends the EAP Request/SIM-Challenge message to the WLAN-UE.

14. WLAN-UE runs N times the GSM A3/A8 algorithms in the SIM, once for each received RAND.

This computing gives N SRES and Kc values.

The WLAN-UE derives additional keying material from N Kc keys and NONCE_MT.

The WLAN-UE calculates its copy of the network authentication MAC with the newly derived keying material and checks that it is equal with the received MAC. If the MAC is incorrect, the network authentication has failed and the WLAN-UE cancels the authentication (not shown in this example). The WLAN-UE continues the authentication exchange only if the MAC is correct.

The WLAN-UE calculates a new MAC with the new keying material covering the EAP message concatenated to the N SRES responses.

If a protected pseudonym was received, then the WLAN-UE stores the pseudonym for future authentications.

15. WLAN-UE sends EAP Response/SIM-Challenge containing calculated MAC to WLAN-AN.

16. WLAN-AN sends the EAP Response/SIM-Challenge packet to 3GPP AAA Server.

17. 3GPP AAA Server compares its copy of the response MAC with the received MAC. If successful, the AAA server shall compare the MAC address, VPLMN Identity and the WLAN radio network information of the authentication exchange with the same information of the ongoing sessions. If the information is the same as with an ongoing session, then the authentication exchange is related to the ongoing session, so there is no need to do anything for the old sessions (skip step 18).

18. Otherwise, the AAA server considers that the authentication exchange is related to a new scenario-2 session. In this case the AAA server shall contact the HSS/HLR for a decision. The AAA server shall inform the HSS/HLR of the WLAN-UE's MAC address, the VPLMN Identity, as well as the identifier of the WLAN radio network used.

19. If the comparison in step 17 is successful, then 3GPP AAA Server sends the EAP Success message to WLAN-AN. If some extra keying material was generated for WLAN technology specific confidentiality and/or integrity protection, then the 3GPP AAA Server includes this derived keying material in the underlying AAA protocol message. (i.e. not at EAP level). The WLAN-AN stores the keying material to be used in communication with the authenticated WLAN-UE.

~~19.~~20. WLAN-AN informs the WLAN-UE about the successful authentication with the EAP Success message. Now the EAP SIM exchange has been successfully completed, and the WLAN-UE and the WLAN_AN may share keying material derived during that exchange.

21. If the same subscriber but different MAC address, or VPLMN identity, or the radio network information is received than in any ongoing session, then the registration is related to a new scenario-2 session. The HSS/HLR shall close an old scenario-2 session by indicating to the 3GPP AAA server of the old session to terminate the session, based on whether simultaneous sessions are not allowed, or whether the number of allowed sessions has been exceeded.

NOTE 4: The derivation of the value of N is for further study.