

Title: SIM Access Profile in split WLAN-UE

Response to:

Source: 3GPP SA3

To: Bluetooth Architecture Review Board (BARB), Bluetooth CAR group and Bluetooth Security Expert Group

Cc:

Contact Person:

Name: Monica Wifvesson

Tel. Number: +46 46 193634

E-mail Address: monica.wifvesson@ericsson.com

Attachments: [S3-030689 \(TS 33.234\)](#)

[S3-030737](#)

[S3-030747](#)

[S3-030738](#)

1. Overall Description:

In the 3GPP WI WLAN Inter-working, 3GPP WG SA3 is currently developing the security architecture, trust model and security requirements for this WI in our TS 33.234 for REL-6 (see attachment S3-030689).

This TS 33.234 contains a number of definitions of the WLAN-UE. The WLAN-UE may be functionally split over several physical devices that communicate over local interfaces e.g. Bluetooth, IR or serial cable interface. As an example, the WLAN-UE may be composed of a TE (e.g. a laptop with a WLAN card) and a GSM/UMTS UE (a mobile phone), equipped with a UICC containing a SIM or USIM application, or a SIM card. The SIM or USIM is required for accessing the 3G WLAN inter-working service. The authentication and key establishment protocol used for this access is either EAP-SIM or EAP-AKA. Such a WLAN-UE may be capable of simultaneous access to both WLAN and 3GPP UMTS/GSM systems.

3GPP UMTS/GSM access

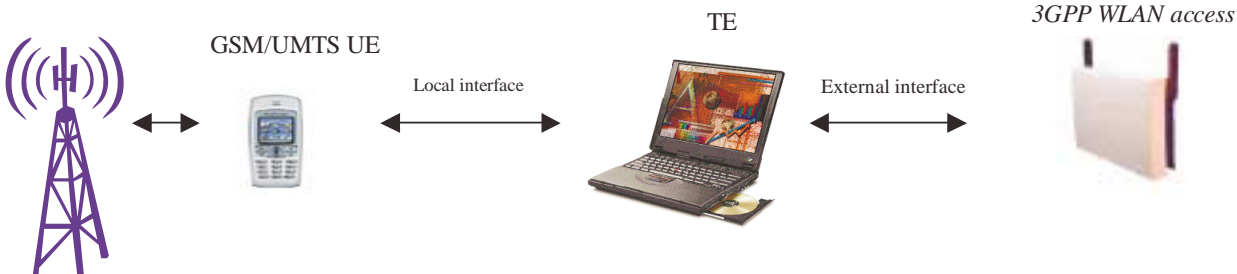

When the local interface between a GSM/UMTS UE and a TE is a Bluetooth link the SIM Access Profile can be used to get SIM access from an external device (e.g. Laptop) to a SIM or UICC inserted into a GSM/UMTS UE.

SA3 is currently investigating the requirements for this split WLAN UE and has concluded on a number of requirements in chapter 2.2 in attachment S3-030737. SA3 would like to point out though that:
-SA3 did not agree on adding a new requirement on integrity protection on the local interface between the TE and GSM/UMTS UE;

-SA3 is still discussing and has not concluded yet on the requirement on where EAP-AKA and EAP-SIM shall terminate (see attachments S3-030738 and S3-030747 for the discussions).

In the attached document S3-030747 three different alternatives were presented at SA3#31:

- Alternative 1: all functions of the EAP peer are executed on the TE, with the exception of the GSM/UMTS cryptographic algorithms on the SIM/USIM. The GSM/UMTS UE acts as a BT SIM Access Profile server, and the TE acts as a BT SIM Access Profile client. The GSM/UMTS UE does not perform any functions of an EAP peer.
- Alternative 2: all functions of the EAP peer are executed on the GSM/UMTS UE, with the exception of the GSM/UMTS cryptographic algorithms on the SIM/USIM. The TE does not perform any functions of an EAP peer.
- Alternative 3: the functional split is as follows: the SIM/USIM performs the GSM/UMTS cryptographic algorithms, the GSM/UMTS UE derives the EAP-SIM or EAP-AKA master key MK from the GSM or UMTS session keys obtained from the SIM or USIM. All the other functions of an EAP peer are performed on the TE.

SA3 identified a threat with alternative 1 described in S3-030747: an attacker obviously can get hold of the GSM or UMTS session keys, and perform attacks not only in WLAN access but also in GSM and UMTS access. Alternative 2 and 3 are foreseen as two potential solutions mitigating this attack that will be discussed further. The issue will be progressed at the next SA3 meeting. Of course SA3 welcome comments from Bluetooth on alternatives 1, 2 and 3. Note that the outcome of this discussion might produce new requirements on the SIM Access Profile protocol from SA3.

In particular, the following requirements have already been identified:

- Alternative 2: all messages of the EAP-SIM and EAP-AKA protocols need to be transferred over the BT local link.
- Alternative 3: the input parameters required for the derivation of the master key MK, as well as an indication of the protocol to be run, need to be transferred from the BT SAP client to the BT SAP server, and MK would have to be transferred in the opposite direction.

SA3 kindly asks Bluetooth for general comments on this usage model with a split WLAN UE in simultaneous WLAN and GSM/UMTS access, whether it is feasible to realise the requirements described in this document as such, and whether it is possible to specify these requirements to the SIM Access Profile: either in the next version of the SIM Access Profile; or in a new Profile developed specifically for this use case of simultaneous access to both WLAN and 3GPP systems.

SA3 is looking forward to future cooperation with Bluetooth on this issue.

2. Actions:

To WG Bluetooth.

ACTION: 3GPP WG SA3 asks Bluetooth:

1. **to provide some general comments on the usage scenario of a split WLAN UE in simultaneous WLAN and GSM/UMTS access, and also whether it is feasible to utilize the SIM Access Profile to realise the requirements described in this document.**
2. **whether Bluetooth think it's feasible in the future to realise the requirements described in this document to the next version of SIM Access Profile or a potentially new profile.**
3. **whether Bluetooth has any comments to the proposals in alternative 1, 2 and 3 in document S3-030747 related to the security concerns to terminate EAP-AKA and EAP-SIM, either in the TE or in the GSM/UMTS UE.**

3. Date of Next 3GPP TSG-SA3 Meetings:

SA3_32	9 th – 13 th February 2004	Edinburgh
SA3_33	11 th – 14 st May 2004	Beijing, China

3GPP TS 33.234 V0.67.0 (2003-0911)

Technical Specification

**3rd Generation Partnership Project;
Technical Specification Group Service and System Aspects;
3G Security;
Wireless Local Area Network (WLAN) Interworking Security;
(Release 6)**



The present document has been developed within the 3rd Generation Partnership Project (3GPP™) and may be further elaborated for the purposes of 3GPP.

The present document has not been subject to any approval process by the 3GPP Organizational Partners and shall not be implemented. This Specification is provided for future development work within 3GPP only. The Organizational Partners accept no liability for any use of this Specification. Specifications and reports for implementation of the 3GPP™ system should be obtained via the 3GPP Organizational Partners' Publications Offices.

Keywords

<keyword[, keyword]>

3GPP

Postal address

3GPP support office address

650 Route des Lucioles - Sophia Antipolis
Valbonne - FRANCE
Tel.: +33 4 92 94 42 00 Fax: +33 4 93 65 47 16

Internet

<http://www.3gpp.org>

Copyright Notification

No part may be reproduced except as authorized by written permission.
The copyright and the foregoing restriction extend to reproduction in all media.

© 2003, 3GPP Organizational Partners (ARIB, CWTS, ETSI, T1, TTA, TTC).
All rights reserved.

Contents

Foreword.....	7
Introduction.....	7
1 Scope.....	8
2 References.....	8
3 Definitions, symbols and abbreviations.....	9
3.1 Definitions.....	9
3.2 Abbreviations.....	9
4 Security Requirements for the 3GPP-WLAN Interworking.....	10
4.1 Security architecture and Roles.....	12
4.1.1 Non roaming WLAN interworking Reference Model.....	12
4.1.2 Roaming WLAN Interworking Reference Model, access to HPLMN services.....	13
4.1.3 Roaming WLAN Interworking Reference Model, access to VPLMN services.....	14
4.1.4 Network elements.....	16
4.1.5 Reference points description.....	16
4.2 Security Requirements.....	17
4.2.1 General.....	17
4.2.2 Signalling and user data protection.....	17
4.2.3 User identity privacy.....	18
4.2.4 WLAN-UE Functional Split.....	18
4.2.5 Link layer security requirements.....	19
4.2.6 UE-initiated tunneling.....	20
5 Security features.....	20
5.1 Authentication of the subscriber and the network and Key Management.....	20
5.1.1 End to End Authentication.....	20
5.1.2 Transport of authentication signalling over the WLAN Radio interface.....	21
5.1.3 Transport of authentication signalling between the WLAN access network and the 3GPP AAA proxy server.....	21
5.1.4 Transport of authentication signalling between the 3GPP AAA proxy server and the 3GPP AAA server.....	21
5.1.5 Transport of authentication signalling between the 3GPP AAA server and the HSS.....	21
5.1.6 User Identity Privacy.....	21
5.1.7 Re-authentication.....	22
5.2 Confidentiality protection.....	22
5.3 Integrity protection.....	23
5.4 Visibility and configurability.....	23
5.5 Immediate Service Termination.....	23
6 Security mechanisms.....	23
6.1 Authentication and key agreement.....	23
6.1.1 USIM-based Authentication.....	23
6.1.1.1 EAP/AKA Procedure.....	23
6.1.2 GSM SIM based authentication.....	29
6.1.3 EAP support in Smart Cards.....	35
6.1.4 Re-authentication mechanisms.....	35
6.2 Confidentiality mechanisms.....	38
6.3 Integrity mechanisms.....	38
6.4 Temporary identity management.....	38
6.4.1 Pseudonym Generation.....	38
6.4.2 Key Management.....	39
6.4.3 Impact on Permanent User Identities.....	40
6.4.4 Acknowledged Limitations.....	40
6.4.5 UE behaviour on receiving requests to send the IMSI-based user identity.....	41
A.1 IEEE.....	42
A.1.1 IEEE 802 Project.....	42

A.1.2	Authentication.....	42
A.1.3	Encryption and integrity protection.....	45
A.2	ETSI/BRAN.....	46
A.2.1	HIPERLAN/2 Security architecture.....	46
A.2.1.1	Confidentiality protection.....	47
A.2.1.2	Authentication.....	48
A.2.1.3	Integrity protection.....	48
A.2.2	Security mechanisms.....	48
A.2.2.1	Confidentiality.....	48
A.2.2.2	Authentication.....	52
A.3	IETF.....	52
A.3.1	Co-Existence of RADIUS and Diameter.....	52
A.4	Bluetooth.....	53
B.1	Trust model entities.....	54
B.2	Trust relations.....	54
C.1	Security for Public WLAN Access.....	56
C.2	Assets and Threats.....	56
C.2.1	3GPP Operator's Assets.....	56
C.2.1.1	Access to WLAN Services.....	56
C.2.1.2	Non-WLAN Assets.....	57
C.2.2	WLAN User's Assets.....	57
C.2.2.1	Access to WLAN Services.....	57
C.2.2.2	User Data and Privacy.....	57
C.2.3	WLAN Access Network Provider's Assets.....	58
C.3	Attacks.....	58
C.3.1	Attacks at the Victim's WLAN UE.....	58
C.3.2	Attacks from an Attacker's WLAN UE and/or AP.....	59
C.3.3	Attacks at the WLAN AN Infrastructure.....	59
C.3.4	Attacks Performed by Other Devices on the Internet.....	59
	Foreword.....	5
	Introduction.....	5
1	Scope.....	6
2	References.....	6
3	Definitions, symbols and abbreviations.....	7
3.1	Definitions.....	7
3.2	Abbreviations.....	7
4	Security Requirements for the 3GPP WLAN Interworking.....	8
4.1	Security architecture and Roles.....	8
4.1.1	Non-roaming WLAN interworking Reference Model.....	8
4.1.2	Roaming WLAN Interworking Reference Model, access to HPLMN services.....	9
4.1.3	Roaming WLAN Interworking Reference Model, access to VPLMN services.....	10
4.1.4	Network elements.....	11
4.1.5	Reference points description.....	11
4.2	Security Requirements.....	12
4.2.1	General.....	12
4.2.2	Signalling and user data protection.....	12
4.2.3	User identity privacy.....	13
4.2.4	WLAN UE Functional Split.....	13
4.2.4.1	General.....	13
4.2.4.2	Security requirements on local interface.....	13
4.2.4.3	Communication over local interface via a Bluetooth link.....	14
4.2.5	Link layer security requirements.....	14
4.2.5.1	Confidentiality and integrity protection of user data.....	14

4.2.5.2 Protection of signalling	14
4.2.5.2 Key distribution, key freshness validation and key ageing	14
4.2.6 UE-initiated tunneling	15
5 Security features	15
5.1 Authentication of the subscriber and the network and Key Management	15
5.1.1 End-to-End Authentication	15
5.1.2 Transport of authentication signalling over the WLAN Radio interface	15
5.1.3 Transport of authentication signalling between the WLAN access network and the 3GPP AAA proxy server	16
5.1.4 Transport of authentication signalling between the 3GPP AAA proxy server and the 3GPP AAA server	16
5.1.5 Transport of authentication signalling between the 3GPP AAA server and the HSS	16
5.1.6 User Identity Privacy	16
5.1.7 Re-authentication	16
5.2 Confidentiality protection	17
5.3 Integrity protection	17
5.4 Visibility and configurability	17
5.5 Immediate Service Termination	17
6 Security mechanisms	17
6.1 Authentication and key agreement	17
6.1.1 USIM-based Authentication	17
6.1.1.1 EAP/AKA Procedure	18
6.1.2 GSM SIM-based authentication	21
6.1.2.1 EAP SIM procedure	21
6.1.3 EAP support in Smart Cards	24
6.1.4 Re-authentication mechanisms	24
6.2 Confidentiality mechanisms	24
6.3 Integrity mechanisms	24
6.4 Temporary identity management	25
6.4.1 Pseudonym Generation	25
6.4.2 Key Management	26
6.4.3 Impact on Permanent User Identities	26
6.4.4 Acknowledged Limitations	27
6.4.5 UE behaviour on receiving requests to send the IMSI-based user identity	27
Annex A (informative): Review of the security of existing WLAN-related technologies	28
A.1 IEEE	28
A.1.1 IEEE 802 Project	28
A.1.2 Authentication	28
A.1.3 Encryption and integrity protection	31
A.2 ETSI/BRAN	32
A.2.1 HIPERLAN/2 Security architecture	32
A.2.1.1 Confidentiality protection	33
A.2.1.2 Authentication	34
A.2.1.3 Integrity protection	34
A.2.2 Security mechanisms	34
A.2.2.1 Confidentiality	34
A.2.2.2 Authentication	38
A.3 IETF	38
A.3.1 Co-Existence of RADIUS and Diameter	38

A.4—Bluetooth.....	39
Annex B (informative): Trust Model	40
B.1—Trust model entities	40
B.2—Trust relations	40
Annex C (informative): Analysis of Threats.....	41
C.1—Security for Public WLAN Access.....	41
C.2—Assets and Threats	41
C.2.1—3GPP Operator's Assets	42
C.2.1.1—Access to WLAN Services	42
C.2.1.2—Non-WLAN Assets	42
C.2.2—WLAN User's Assets	42
C.2.2.1—Access to WLAN Services	42
C.2.2.2—User Data and Privacy	43
C.2.3—WLAN Access Network Provider's Assets	43
C.3—Attacks	43
C.3.1—Attacks at the Victim's WLAN UE.....	44
C.3.2—Attacks from an Attacker's WLAN UE and/or AP	44
C.3.3—Attacks at the WLAN AN Infrastructure	45
C.3.4—Attacks Performed by Other Devices on the Internet	45
Annex D (informative): Management of sequence numbers.....	45
Annex E (informative): Change history.....	46

Foreword

This Technical Specification has been produced by the 3rd Generation Partnership Project (3GPP).

The contents of the present document are subject to continuing work within the TSG and may change following formal TSG approval. Should the TSG modify the contents of the present document, it will be re-released by the TSG with an identifying change of release date and an increase in version number as follows:

Version x.y.z

where:

- x the first digit:
 - 1 presented to TSG for information;
 - 2 presented to TSG for approval;
 - 3 or greater indicates TSG approved document under change control.
- y the second digit is incremented for all changes of substance, i.e. technical enhancements, corrections, updates, etc.
- z the third digit is incremented when editorial only changes have been incorporated in the document.

Introduction

WLAN is not a single radio technology, several different technologies fall into the category called WLAN. Existing industry standard is IEEE 802.11b operating at 2,4 GHz ISM band. New entrant for this same band is Bluetooth and technologies such as IEEE 802.11a and ETSI BRAN Hiperlan2 are being developed for the 5GHz band.

Despite the different radio technologies, all these WLAN systems are commonly used for transportation of IP datagrams. The specific WLAN technology used in each wireless IP network is not very visible for the layers above IP.

TSG SA WG3 will need to understand the models and mechanisms under which these technologies can be used to securely interwork with 3GPP networks.

1 Scope

The present document specifies the security architecture, trust model and security requirements for the interworking of the 3GPP System and WLAN Access Networks.

Recommendations of the appropriate mechanisms for user and network authentication, key management, service authorization, confidentiality and integrity protection of user and signalling data are also provided.

2 References

The following documents contain provisions which, through reference in this text, constitute provisions of the present document.

- References are either specific (identified by date of publication, edition number, version number, etc.) or non-specific.
- For a specific reference, subsequent revisions do not apply.
- For a non-specific reference, the latest version applies. In the case of a reference to a 3GPP document (including a GSM document), a non-specific reference implicitly refers to the latest version of that document *in the same Release as the present document*.

- [1] 3GPP TR 22.934: " Feasibility study on 3GPP system to Wireless Local Area Network (WLAN) interworking;".
- [2] 3GPP TR 23.934: "3GPP system to Wireless Local Area Network (WLAN) Interworking; Functional and architectural definition".
- [3] RFC 2284, March 1998, "PPP Extensible Authentication Protocol (EAP)".
- [4] draft-arkko-pppext-eap-aka-06, November 2002, "EAP AKA Authentication".
- [5] draft-haverinen-pppext-eap-sim-07, November 2002, "EAP SIM Authentication".
- [6] IEEE Std 802.11i/D2.0, March 2002, "Draft Supplement to STANDARD FOR Telecommunications and Information Exchange Between Systems - LAN/MAN Specific Requirements - Part 11: Wireless Medium Access Control (MAC) and physical layer (PHY) specifications: Specification for Enhanced Security".
- [7] RFC 2716, October 1999, "PPP EAP TLS Authentication Protocol".
- [8] SHAMAN /SHA/DOC/TNO/WP1/D02/v050, 22-June-01, "Intermediate Report: Results of Review, Requirements and Reference Architecture".
- [9] ETSI TS 101 761-1 v1.3.1B "Broadband Radio Access Networks (BRAN); HIPERLAN Type 2; Data Link Control (DLC) layer; Part 1: Basic Data Transport".
- [10] ETSI TS 101 761-2 v1.2.1C "Broadband Radio Access Networks (BRAN); HIPERLAN Type 2; Data Link Control (DLC) layer; Part 2: Radio Link Control (RLC) sublayer".
- [11] ETSI TS 101 761-4v1.3.1B "Broadband Radio Access Networks (BRAN); HIPERLAN Type 2; Data Link Control (DLC) layer; Part 4 Extension for Home Environment".
- [12] ETSI TR 101 683 v1.1.1 "Broadband Radio Access Networks (BRAN); HIPERLAN Type 2; System Overview".
- [13] 3GPP TS 23.234 "3GPP system to Wireless Local Area Network (WLAN) Interworking System Description".
- [14] RFC 2486, January 1999, "The Network Access Identifier".
- [15] RFC 2865, June 2000, "Remote Authentication Dial In User Service (RADIUS)".

- [16] RFC 1421, February 1993, "Privacy Enhancement for Internet Electronic Mail: Part I: Message Encryption and Authentication Procedures".
- [17] Federal Information Processing Standard (FIPS) draft standard, "Advanced Encryption Standard (AES)", November 2001.
- [18] 3GPP TS 23.003: "Numbering, addressing and identification".
- [19] IEEE P802.1X/D11 June 2001, "Standards for Local Area and Metropolitan Area Networks: Standard for Port Based Network Access Control".
- [20] 3GPP TR 21.905: "Vocabulary for 3GPP Specifications".
- [21] 3GPP TS 33.102: "3rd Generation Partnership Project; Technical Specification Group Services and System Aspects; 3G Security; Security Architecture".
- [22] SIM Access Profile, Interoperability Specification, version 0.95VD - d. Document no. CAR 020 SPEC/0.95cB
- [23] [draft-ietf-aaa-eap-02.txt](#), June 2003, "Diameter Extensible Authentication Protocol (EAP) Application".
- [24] [RFC 3588](#), September 2003, "Diameter base protocol".
- [25] [RFC 3576](#), July 2003, "Dynamic Authorization Extensions to Remote Authentication Dial In User Service (RADIUS)".

3 Definitions, symbols and abbreviations

3.1 Definitions

For the purposes of the present document, the following terms and definitions apply:

Data origin authentication: The corroboration that the source of data received is as claimed.

Entity authentication: The provision of assurance of the claimed identity of an entity.

Key freshness: A key is fresh if it can be guaranteed to be new, as opposed to an old key being reused through actions of either an adversary or authorised party.

WLAN coverage: an area where wireless local area network access services are provided for interworking by an entity in accordance with WLAN standards.

WLAN-UE: user equipment to access a WLAN interworking with the 3GPP system, including all required security functions.

[Editors note This WLAN-UE definition needs to be reflected in related specifications]

3.2 Abbreviations

For the purposes of the present document, the following abbreviations apply, [20] contains additional applicable abbreviations:

AAA	Authentication Authorisation Accounting
AKA	Authentication and Key Agreement
EAP	Extensible Authentication Protocol
WLAN	Wireless Local Area Network

4 Security Requirements for the 3GPP-WLAN Interworking

[Editor's note: This section shall have a description of the overall architecture for the 3G-WLAN interworking system and a list of the identified security requirements]

4.1 Security architecture and Roles

Editor's note: The network diagrams in this section are provisional and depend on the tunnel decision taken by SA2

Note: the pictures in this chapter may contain a shaded area, which surrounds the entities for scenario 3.

4.1.1 Non-roaming WLAN interworking Reference Model

The home network is responsible for access control and tunnel establishment

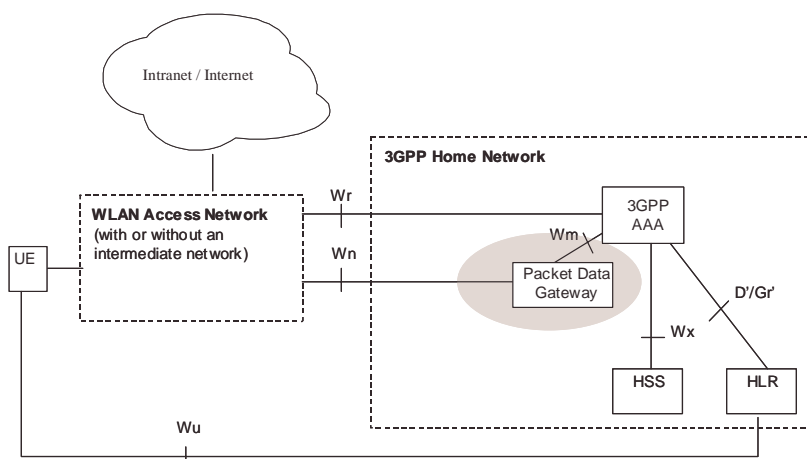

Figure 4.1 Non-roaming reference model

4.1.2 Roaming WLAN Interworking Reference Model, access to HPLMN services

The home network is responsible for access control, although the VPLMN may take part in tunnel establishment (if one of the end points is the WAG).

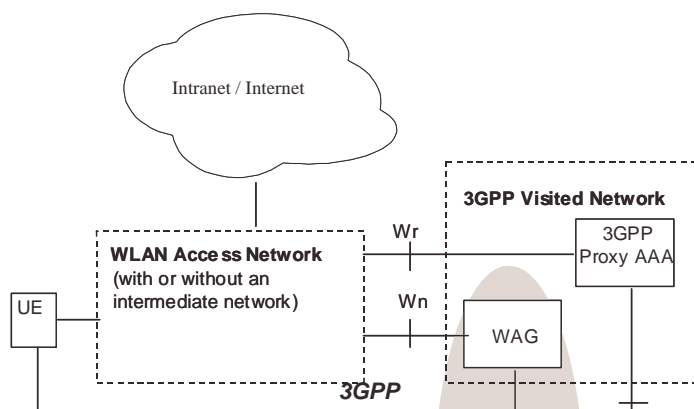

Figure 4.2 Roaming reference model, services in the HPLMN

4.1.3 ~~Roaming WLAN Interworking Reference Model, access to VPLMN services~~

~~The home network is responsible for access control, but the authorization decision of tunnel establishment will be taken by the 3GPP proxy AAA based on own information plus information received from the home network. The VPLMN will take part in tunnel establishment (either the WAG or the PDGW).~~

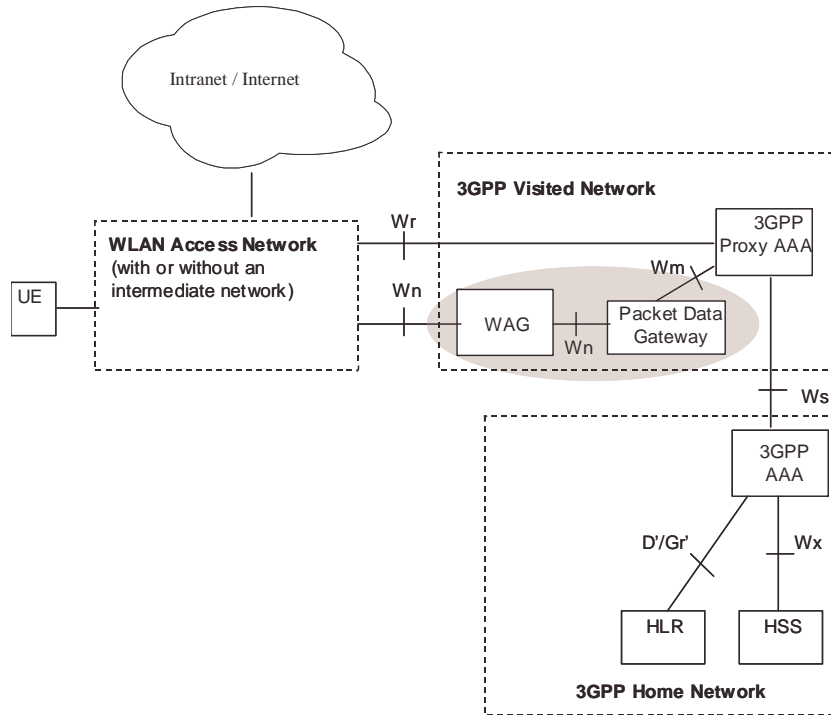

Figure 4.3 Roaming reference model, services in the VPLMN

4.1 Security architecture and Roles

Note: the pictures in this chapter may contain a shaded area, which surrounds the entities for scenario 3.

4.1.1 Non roaming WLAN interworking Reference Model

The home network is responsible for access control and tunnel establishment.

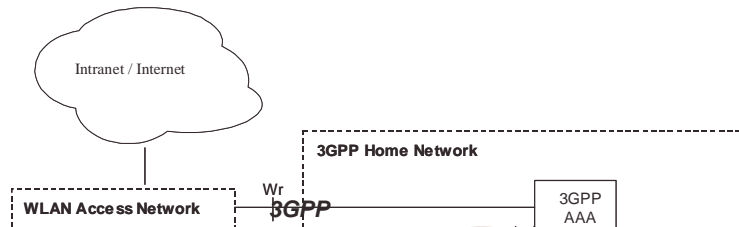

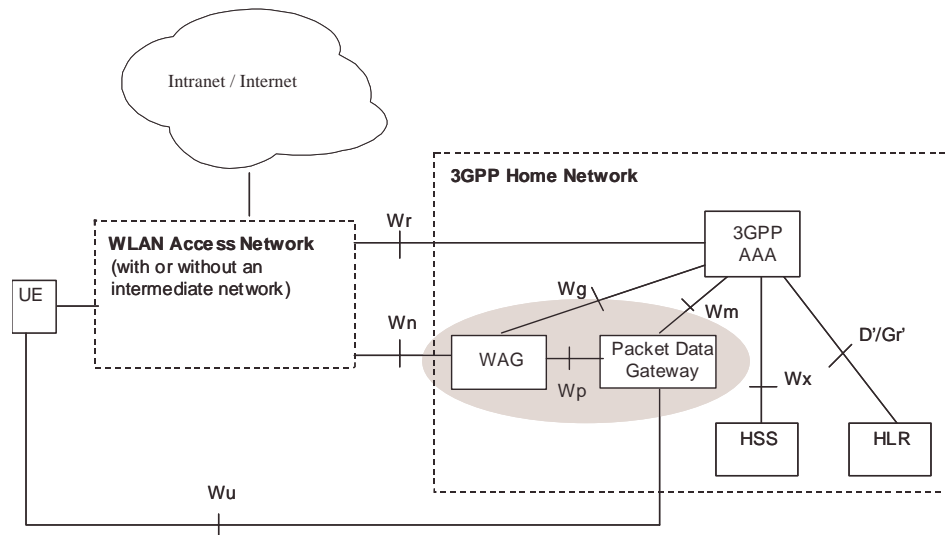
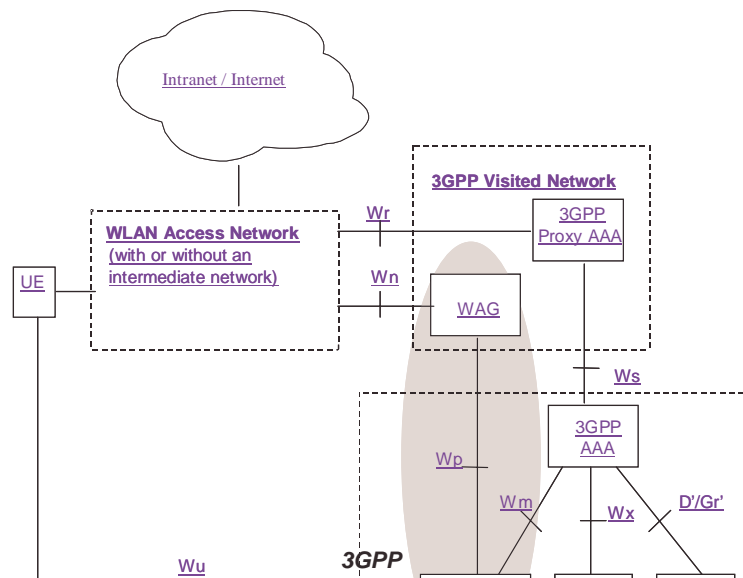

Figure 4.1 Non roaming reference model

4.1.2 Roaming WLAN Interworking Reference Model, access to HPLMN services

The home network is responsible for access control and tunnel establishment. The traffic is routed through the visited network (using the WAG).



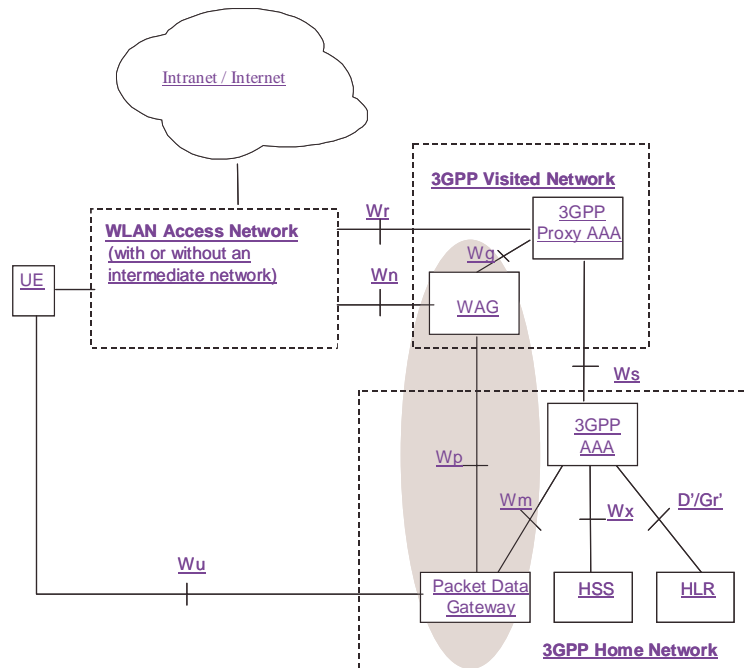
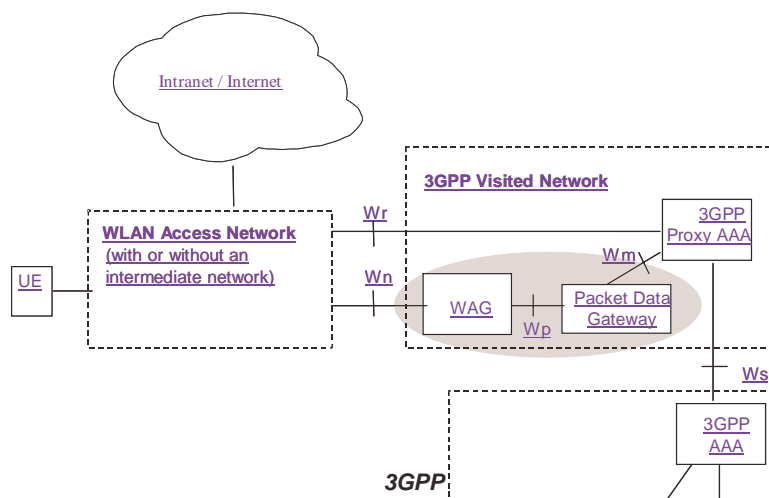

Figure 4.2 Roaming reference model, services in the HPLMN

4.1.3 Roaming WLAN Interworking Reference Model, access to VPLMN services

The home network is responsible for access control, but the authorization decision of tunnel establishment will be taken by the 3GPP proxy AAA based on own information plus information received from the home network. The VPLMN will take part in tunnel establishment (either the WAG or the PDGW).



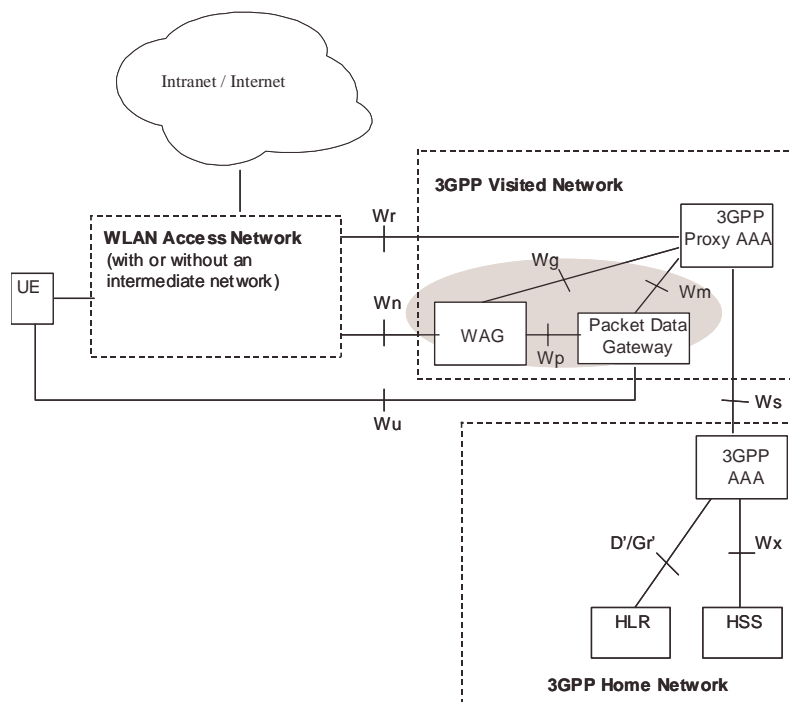

Figure 4.3 Roaming reference model, services in the VPLMN

4.1.4 Network elements

The list below describes the access control related functionality in the network elements of the 3GPP-WLAN interworking reference model:

- the **WLAN-UE**, equipped with a UICC (or SIM card), for accessing the WLAN interworking service):
 - may be capable of WLAN access only;
 - may be capable of both WLAN and 3GPP System access;
 - may be capable of simultaneous access to both WLAN and 3GPP systems;

[Editors note: definition of simultaneous access still TBA with SA1- LS in S3 030169] Reply to SA2 in S3-030188 provides some clarification

- May be a laptop computer or PDA with a WLAN card, UICC (or SIM card) card reader, and suitable software applications;
- May be functionally split over several physical devices, that communicate over local interfaces e.g. Bluetooth, IR or serial cable interface;

[Editors Note: All these alternatives must be carefully studied from a security perspective.]

- the **AAA proxy** represents a logical proxying functionality that may reside in any network between the WLAN and the 3GPP AAA Server. These AAA proxies are able to relay the AAA information between WLAN and the 3GPP AAA Server.
The number of intermediate AAA proxies is not restricted by 3GPP specifications. The AAA proxy functionality can reside in a separate physical network node, it may reside in the 3GPP AAA server or any other physical network node;
- the **3GPP AAA server** is located within the 3GPP network. The 3GPP AAA server:
 - retrieves authentication information from the HLR/HSS of the 3GPP subscriber's home 3GPP network;
 - authenticates the 3GPP subscriber based on the authentication information retrieved from HLR/HSS. The authentication signalling may pass through AAA proxies;
 - communicates authorisation information to the WLAN potentially via AAA proxies.
- The **Packet Data Gateway (PDGW)** enforces tunnel authorization and establishment with the information received from the 3GPP AAA via the Wm interface.

*Note: The **WLAN Access Gateway (WAG)** responsibilities for security issues are related to tunnel establishment but this decision is pending to be taken.*

4.1.5 Reference points description

Wr

The reference point Wr connects the WLAN Access Network to the 3GPP Network (i.e. the 3GPP AAA Proxy in the roaming case and the 3GPP AAA server in the non-roaming case). The main purpose of the protocols implementing this interfaces is to transport authentication and keying information (WLAN UE - 3GPP network), and authorization information (WLAN AN – 3GPP network). The reference point has to accommodate also legacy WLAN Access Networks and thus should be Diameter or RADIUS based.

Wx

This reference point is located between 3GPP AAA Server and HSS. The main purpose of the protocols implementing this interface is communication between WLAN AAA infrastructure and HSS, and more specifically the retrieval of authentication vectors, e.g. for USIM authentication, and retrieval of WLAN access-related subscriber information from HSS. The protocol is either MAP or Diameter based.

D'/Gr'

This optional reference point is located between 3GPP AAA Server and pre-R6 HLR/HSS. The main purpose of the protocol implementing this interface is communication between WLAN AAA infrastructure and HLR, and more specifically the retrieval of authentication vectors, e.g. for USIM authentication, from HLR.. The protocol is MAP-based.

Wn

The definition of this reference point is for further study

Wm

This reference point is located between 3GPP AAA Server and Packet Data Gateway. The functionality of this reference point is to retrieve tunnelling attributes and UE's IP configuration parameters from/via Packet Data Gateway.

Ws

The reference point Ws connects the 3GPP AAA Proxy to the 3GPP AAA Server. This interface is similar to Wr, its main purpose is to transport authentication, authorization and related information in a secure manner.

4.2 Security Requirements

4.2.1 General

- The authentication scheme shall be based on a challenge response protocol.
- All long-term security credentials used for subscriber and network authentication shall be stored on UICC or SIM card.
- Long term security credentials, which are stored on the UICC or SIM card, shall not leave the UICC or SIM card.
- Mutual Authentication shall be supported.

4.2.2 Signalling and user data protection

- The subscriber should have at least the same security level for WLAN access as for his current cellular access subscription.

- 3GPP systems should support authentication methods that support protected success/failure indications. Editors note: FFS if this is possible.
- The selected WLAN (re-) authentication mechanisms for 3GPP interworking shall provide at least the same level of security as [33.102] for USIM based access.
- The selected WLAN (re-authentication mechanism for 3GPP interworking shall provide at least the same level of security as [43.020] for SIM based access.
- Selected WLAN Authentication mechanisms for 3GPP interworking shall support agreement of session keying material.
- 3GPP systems should provide the required keying material with sufficient length and the acceptable levels of entropy as required by the WLAN subsystem

[Editors note: LS (S3-030166) sent to IEEE 802.11-task group i on their requirements over key length and entropy of keying material]

- Selected WLAN key agreement and key distribution mechanism shall be secure against man in the middle attacks.
- Protection should be provided for WLAN authentication data and keying material on the Wr, Ws and Wx interfaces.
- The WLAN technology specific connection between the WLAN-UE and WLAN AN shall be able to utilise the generated session keying material for protecting the integrity of an authenticated connection.

[Editor's note: Threats on the Wr interface are not clear yet, so protection on this interface is FFS]

4.2.3 User identity privacy

- Any secret keys used in 3G AAA servers for the generation of pseudonyms should be infeasible for an attacker to recover.
- It shall be infeasible for an attacker to recover the corresponding permanent identity, given any pseudonym(s).
- It should be infeasible for an attacker to determine whether or not two pseudonyms correspond to the same permanent identity.
- It shall be infeasible for an attacker to generate a valid pseudonym.

4.2.4 WLAN-UE Functional Split

4.2.4.1 General

In the case when the WLAN-UE, equipped with a UICC (or SIM card), for accessing the WLAN interworking service, is functionally split over several physical devices, that communicate over local interfaces e.g. Bluetooth, IR or serial cable interface, then it shall be:

- Possible to re-use existing UICC and GSM SIM cards; and

[Editor's note: The termination point of EAP is for further study e.g. if EAP-AKA and EAP-SIM shall terminate in the TE e.g. laptop computer }.

4.2.4.2 Security requirements on local interface

The security functionality required on the terminal side for WLAN-3G interworking may be split over several physical devices that communicate over local interfaces. If this is the case, then the following requirements shall be satisfied:

- Any local interface shall be protected against eavesdropping, undetected modification attacks on security-relevant information. This protection may be provided by physical or cryptographic means.

- The endpoints of a local interface should be authenticated and authorised. The authorisation may be implicit in the security set-up.
- The involved devices shall be protected against eavesdropping, undetected modification attacks on security-relevant information. This protection may be provided by physical or cryptographic means.

[Editor's note: New work item approved at SA3#28" U(SIM) Security Reuse by Peripheral Device on local Interfaces" (S3-030307). The Local interface" undetected modification" requirement - cryptographic requirement for short range e.g. Bluetooth is FFS pending the completion of this WI]

4.2.4.3 Communication over local interface via a Bluetooth link

For SIM access via a Bluetooth link, the SIM Access Profile developed in BLUETOOTH SIG forum may be used, see [2+2].

[Editor note: The version of the SIM Access Profile specification in the reference needs to be updated, if SA3 decides that a new version is required.]

4.2.5 Link layer security requirements

[Editors note: This section is FFS, LS (S3-030167) sent to SA2 group. On 1) the need for requiring 802.11i in TS 23.234. SA2 to explain the impact (if any) a change of technology from 802.11i to WPA would have on the standardisation work. 2) SA2 to study the architectural impacts of implementing protection on W interface 3) SA2 to Investigate the importance of specifying specific WLAN technologies to be used for the WLAN access network]

Most WLAN technologies provide (optional) link-layer protection of user data. Since the wireless link is likely to be the most vulnerable in the entire system, 3GPP-WLAN interworking should take advantage of the link layer security provided by WLAN technologies. The native link-layer protection can also prevent against certain IP-layer attacks.

In order to set the bar for allowed WLAN protocols, 3GPP should define requirements on link layer security. The existing and work-in-progress WLAN standards can then be evaluated based on these requirements.

Areas in which requirements should be defined are:

4.2.5.1 Confidentiality and integrity protection of user data

- Can user data be sent in the clear or is some kind of protection required?
- Is it enough to integrity protect user data or should it be encrypted as well?
- How strong must the WLAN security protocols be? Compare e.g. WEP, TKIP and CCMP in the case of 802.11 WLAN.

4.2.5.2 Protection of signalling

- What implications on 3GPP-WLAN security does it have if the WLAN control signalling is unprotected? (Currently 802.11 management frames are not protected by 802.11i).

4.2.5.2 Key distribution, key freshness validation and key ageing

- Can encryption keys generated during EAP authentication be used directly as encryption keys for the link layer or must there be a handshake between UE and AP to e.g. ensure freshness? (Like the 4-way handshake of 802.11i).
- What are the security implications of not having a UE-AP key handshake?

4.2.6 UE-initiated tunneling

The security features that are expected in a tunnel from the UE to the VPLMN or HPLMN will be:

- Data origin authentication and integrity must be supported.
- Confidentiality must be supported.
- The 3GPP network has the ultimate decision to allow tunnel establishment, based on:
 - o The level of trust in the WLAN AN and/or VPLMN
 - o The capabilities supported in the WLAN UE
 - o Whether the user is authorized or not to access the services (in the VPLMN or HPLMN) the tunnel will give access to.
- The 3GPP network, in the setup process, decides the characteristics (encryption algorithms, protocols,...) under which the tunnel will be established.

Note: Authorization for the tunnel establishment is decided by the 3GPP AAA and enforce by the PDGW or WAG. Whether this authorization information is protected or not is FFS.

Working assumptions:

1. IPsec ESP will be used to protect the tunnels between UE and PDG required by scenario 3.
2. The security mechanisms used in context with the IP tunnel in scenario 3 are to be independent of the link layer security in scenario 2. [Editors note: The independence requirement is not for security reasons. If the solution developed implies significant inefficiencies then this would be reported to SA WG2 for possible revision of this independence requirement.]
3. Further study will concentrate on IKE and IKEv2 for setting up the keys for IPsec ESP.

Further work identified for SA3

1. Define a profile of IPsec ESP for use with scenario 3.
2. Standardise the set-up of security associations for IPsec ESP between UE and PDG.

5 Security features

[Editor's note: This section shall explain the provided security features in detail]

5.1 Authentication of the subscriber and the network and Key Management

[Editor's note: This section shall deal with subscriber identity and authentication of the subscriber and Home Network/Serving Network. The authentication and key management mechanisms fulfilling the requirements in chapter 4 shall be listed here]

5.1.1 End to End Authentication

WLAN Authentication signalling is executed between WLAN-UE and 3GPP AAA Server. This authentication signalling shall be independent on the WLAN technology utilised within WLAN Access network.. WLAN authentication signalling for 3GPP-WLAN interworking shall be based on Extensible Authentication Protocol (EAP) as specified in RFC 2284 (ref. [3])

5.1.2 Transport of authentication signalling over the WLAN Radio interface

WLAN authentication signalling is carried between WLAN-UE and WLAN Access Network by WLAN Access Technology specific protocols. These WLAN technology specific protocols shall be able to meet the security requirements set for WLAN Access control in 3GPP-WLAN interworking. To ensure multi-vendor interoperability these WLAN technology specific protocols shall conform to existing standards of the specific WLAN access technology. For IEEE 802.11 type of WLAN radio interfaces the WLAN radio interface shall conform to IEEE 802.11i standard (ref. [6]).

5.1.3 Transport of authentication signalling between the WLAN access network and the 3GPP AAA proxy server

WLAN Authentication signalling shall be transported over Wr reference point by standard mechanisms, which are independent on the specific WLAN technology utilised within the WLAN Access network. The transport of Authentication signalling over Wr reference point shall be based on standard Diameter or RADIUS protocols.

5.1.4 Transport of authentication signalling between the 3GPP AAA proxy server and the 3GPP AAA server

WLAN Authentication signalling shall be transported over Ws reference point by standard mechanisms.

5.1.5 Transport of authentication signalling between the 3GPP AAA server and the HSS

WLAN Authentication signalling shall be transported over Wx reference point by standard mechanisms.

5.1.6 User Identity Privacy

User identity privacy (Anonymity) is used to avoid sending the cleartext permanent subscriber identity (NAI) and make the subscriber's connections unlinkable to eavesdroppers.

User identity privacy is based on temporary identities, or pseudonyms. The procedures for distributing, using and updating temporary identities are described in ref. [4] and [5]. Support of this feature is mandatory for implementations, but optional for use.

The AAA server generates and delivers the pseudonym to the WLAN-UE as part of the authentication process. The WLAN-UE shall not interpret the pseudonym, it will just store the received identifier and use it at the next authentication. Clause 6.4 describes a mechanism that allows the home network to include the user's identity (IMSI) encrypted within the pseudonym.

To avoid user traceability, the user should not be identified for a long period by means of the same temporary identity. On the other hand, the AAA server should be ready to accept at least two different pseudonyms, in case the WLAN-UE fails to receive the new one issued from the AAA server. The mechanism described in Clause 6.4 also includes facilities to maintain more than one allowed pseudonym.

If identity privacy is used but the AAA server cannot identify the user by its pseudonym, the AAA server requests the user to send its permanent identity. This represents a breach in the provision of user identity privacy. It is a matter of the operator's security policy whether to allow clients to accept requests from the network to send the cleartext permanent identity. If the client rejects a legitimate request from the AAA server, it will be denied access to the service.

[Editor's note: The use of PEAP with EAP/AKA and EAP/SIM is currently under consideration. If PEAP is used, the temporary identity privacy scheme provided by EAP/AKA and EAP/SIM is not needed.]

5.1.7 Re-authentication

[Editor's note: The text below requires further study—SA3 have identified areas that will need to be enhanced with further contributions from SA3 delegates. For example, the rules on the ratio between full SIM/USIM authentication and the re-authentication method and the exact details of the replay protection scheme require further study.]

"On some networks, EAP authentication may be performed frequently. For such cases, EAP SIM and EAP AKA include an optional re-authentication procedure. Re-authentication causes less load on the network and is faster to execute than the full SIM/USIM authentication procedure. Re-authentication is optional to implement for both the WLAN UE and 3GPP AAA server. On each EAP authentication, either one of the entities may also fall back on full authentication if they do not want to use re-authentication. Re-authentication is based on the keys derived on the preceding full authentication.

On re-authentication, the UE protects against replays with an unsigned 16-bit counter. The server includes an encrypted server nonce (NONCE_S) in the re-authentication request. The Message Authentication Code attribute in the client's response is calculated over NONCE_S to provide a challenge/response authentication scheme. The NONCE_S also contributes to the new session keys.

Because one of the objectives of the re-authentication procedure is to reduce load on the network, the re-authentication procedure does not require the 3GPP AAA server to contact a reliable database. Therefore, the re-authentication procedure makes use of separate re-authentication user identities. Pseudonyms and the permanent IMSI-based identity are reserved for full authentication only. The network does not need to store re-authentication identities as carefully as pseudonyms. If a re-authentication identity is lost and the network does not recognize it, the 3GPP AAA server can fall back on full authentication.

If the 3GPP server supports re-authentication, it may communicate an encrypted re-authentication identity for next re-authentication to the WLAN UE during full authentication. If the client wants to use re-authentication, it uses this re-authentication identity on next authentication."

WLAN re-authentication is performed between WLAN-UE and AAA server, through Ws and Wr interfaces.

The WLAN-AN can initiate the re-authentication process periodically. The frequency of the re-authentications is determined by a counter which normally is set by O&M procedures in the WLAN-AN but it can be sent to the WLAN-AN by the AAA server in a RADIUS or Diameter message (in the attribute Session Timeout). At reception of this attribute, the WLAN-AN may substitute the previously set counter by the received one. Nevertheless, the 3GPP network does not have the certainty that the counter sent by the AAA server is enforced by the WLAN AN, since the latter may not support this feature (the reception and acceptance of the Session Timeout attribute). In this case, the WLAN AN will discard it and trigger the re-authentications in the period set by O&M procedures as mentioned before.

The re-authentication process initiated by the WLAN-AN will be performed either with a full authentication process or with a fast re-authentication process (from now on it will be simply called re-authentication). When the process is triggered by the WLAN AN, it is the client's decision to perform either a full authentication or a re-authentication (fast). This is indicated to the WLAN AN by sending either a pseudonym (full authentication) or a re-authentication id (fast). Both processes are described in this TS.

The re-authentication process must be implemented together with the full authentication procedure, although its use is optional and depends on operators' policies. These policies depend on the level of trust of the 3GPP operator and the WLAN AN, and the possible threats detected by operator which may require a periodic refresh of keys. The full process description can be found in ref. [4] and [5].

Note: it is still pending to define how the re-authentication id is generated.

5.2 Confidentiality protection

[Editor's note: This section shall deal with what confidentiality protection that is provided between different nodes both inter domain, intra domain and the WLAN-UE. It shall justify the selected mechanisms (hop-by-hop or end-to-end) and protection at different layers]

5.3 Integrity protection

[Editor's note: This section shall deal with what integrity protection that is provided between different nodes both inter domain, intra domain and the WLAN-UE. It shall justify the selected mechanisms (hop-by-hop or end-to-end) and protection at different layers]

5.4 Visibility and configurability

[Editor's note: This section shall contain what the subscriber shall be able to configure and what is visible for the subscriber regarding the actual protection the subscriber is provided with.]

5.5 Immediate Service Termination

~~[Editor's note: This section shall deal with the network capability to terminate ongoing subscriber activities in the WLAN access when this is required due to e.g. end of subscription, expiration of charging account, detection of fraudulent activities, etc.]~~The AAA server initiates immediate service termination when some events may require stopping user's activity (end of subscription, expiration of charging account, etc.). This process can be initiated at any time by the AAA server with the Diameter command Diameter-Abort-Session-Request and Diameter-Abort-Session-Answer (the Ws interface is implemented with Diameter protocol) as specified in [24]. The AAA proxy will just forward this procedure to the WLAN AN through Wr interface if the latter supports Diameter. If it supports RADIUS, the AAA proxy will map the procedure to the RADIUS messages Disconnect-Request and Disconnect-Response as specified in [25].

6 Security mechanisms

[Editor's note: This section shall describe the security mechanisms that are provided inter domain, intra domain and to the WLAN-UE.]

6.1 Authentication and key agreement

[Editor's note: This section shall describe in detail how the authentication is performed and how the keys are derived and delivered to the different nodes.]

[Editor's note: The content of this section is directly copied from TS 23.xxx v0.1.0 and shall be reviewed by SA3]

6.1.1 USIM-based Authentication

USIM based authentication is a proven solution that satisfies the authentication requirements from section 4.2. This form of authentication shall be based on EAP-AKA (ref. [4]), as described in section 6.1.1.1.

[Editor's note: also see section 4.2.4 on WLAN-UE Functional Split]

6.1.1.1 EAP/AKA Procedure

The EAP-AKA authentication mechanism is specified in ref. [4]. The present section describes how this mechanism is used in the WLAN-3GPP interworking scenario.

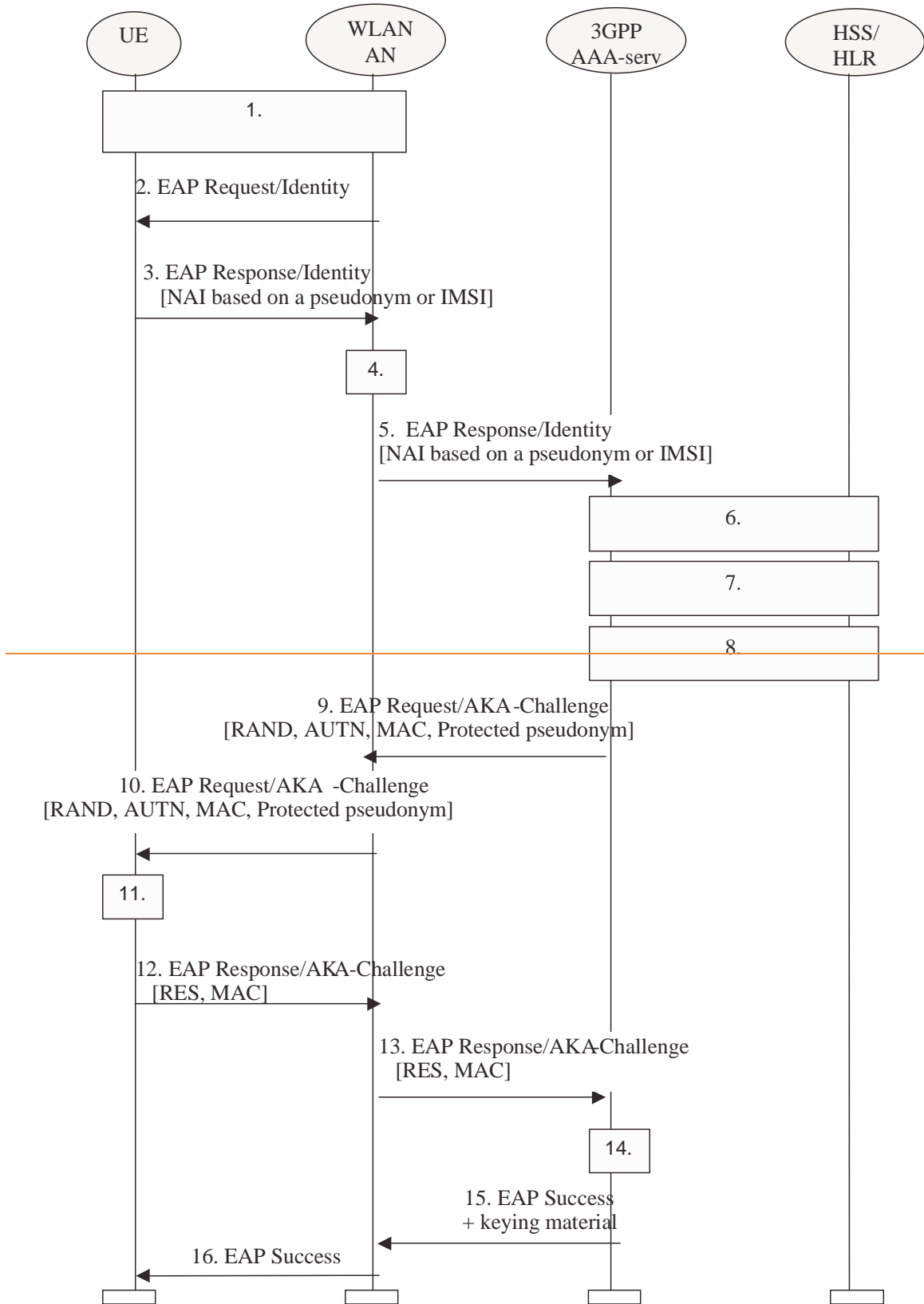

Figure 7.1: Authentication based on EAP AKA scheme

1. A connection is established between the WLAN UE and the WLAN AN, using a Wireless LAN technology specific procedure (out of scope for this specification).

- ~~2. The WLAN AN sends an EAP Request/Identity to the WLAN UE.~~
 - ~~— EAP packets are transported over the Wireless LAN interface encapsulated within a Wireless LAN technology specific protocol.~~
- ~~3. The WLAN UE sends an EAP Response/Identity message. The WLAN UE sends its identity complying with Network Access Identifier (NAI) format specified in RFC 2486. NAI contains either a temporary identifier (pseudonym) allocated to WLAN UE in previous authentication or, in the case of first authentication, the IMSI.~~

~~NOTE:— Generating an identity conforming to NAI format from IMSI is defined in EAP/AKA [4]~~
- ~~4. The message is routed towards the proper 3GPP AAA Server based on the realm part of the NAI. The routing path may include one or several AAA proxies (not shown in the figure).~~

~~NOTE:— Diameter referral can also be applied to find the AAA server.~~
- ~~5. The 3GPP AAA server receives the EAP Response/Identity packet that contains the subscriber identity.~~
- ~~6. 3GPP AAA Server identifies the subscriber as a candidate for authentication with EAP AKA, based on the received identity. The 3GPP AAA Server then checks that it has an unused authentication vector available for that subscriber. If not, a set of new authentication vectors is retrieved from HSS/HLR. A mapping from the temporary identifier to the IMSI may be required.~~

~~NOTE:— It could also be the case that the 3GPP AAA Server first obtains an unused authentication vector for the subscriber and, based on the type of authenticator vector received (i.e. if a UMTS authentication vector is received), it regards the subscriber as a candidate for authentication with EAP AKA.~~
- ~~7. 3GPP AAA server checks that it has the WLAN access profile of the subscriber available. If not, the profile is retrieved from HSS. 3GPP AAA Server verifies that the subscriber is authorized to use the WLAN service.~~
 - ~~— Although this step is presented after step 6 in this example, it could be performed at some other point, however before step 14. (This will be specified as part of the Wx interface.)~~
- ~~8. New keying material is derived from IK and CK., cf. [4]. This keying material is required by EAP AKA, and some extra keying material may also be generated for WLAN technology specific confidentiality and/or integrity protection.~~
 - ~~— A new pseudonym may be chosen and protected (i.e. encrypted and integrity protected) using EAP AKA generated keying material.~~
- ~~9. 3GPP AAA Server sends RAND, AUTN, a message authentication code (MAC) and protected pseudonym (in case it was generated) to WLAN AN in EAP Request/AKA Challenge message.~~
- ~~10. The WLAN AN sends the EAP Request/AKA Challenge message to the WLAN UE.~~
- ~~11. WLAN UE runs UMTS algorithm on the USIM. The USIM verifies that AUTN is correct and hereby authenticates the network. If AUTN is incorrect, the terminal rejects the authentication (not shown in this example). If the sequence number is out of synch, terminal initiates a synchronization procedure, c.f. [4]. If AUTN is correct, the USIM computes RES, IK and CK.~~
 - ~~— Using IK and CK the WLAN UE checks the received MAC and derives required additional keying material~~
 - ~~— If a protected pseudonym was received, then the WLAN UE stores the pseudonym for future authentications.~~
- ~~12. WLAN UE sends EAP Response/AKA Challenge containing calculated RES and a new MAC value to WLAN AN~~
- ~~13. WLAN AN sends the EAP Response/AKA Challenge packet to 3GPP AAA Server~~
- ~~14. 3GPP AAA Server checks the received MAC and compares XRES to the received RES.~~
- ~~15. If all checks in step 14 are successful, then 3GPP AAA Server sends the EAP Success message to WLAN AN. If some extra keying material was generated for WLAN technology specific confidentiality and/or integrity protection then the 3GPP AAA Server includes this keying material in the underlying AAA protocol message (i.e. not at EAP level). The WLAN AN stores the keying material to be used in communication with the authenticated WLAN UE.~~

~~16. WLAN AN informs the WLAN UE about the successful authentication with the EAP Success message. Now the EAP AKA exchange has been successfully completed, and the WLAN UE and the WLAN AN share keying material derived during that exchange.~~

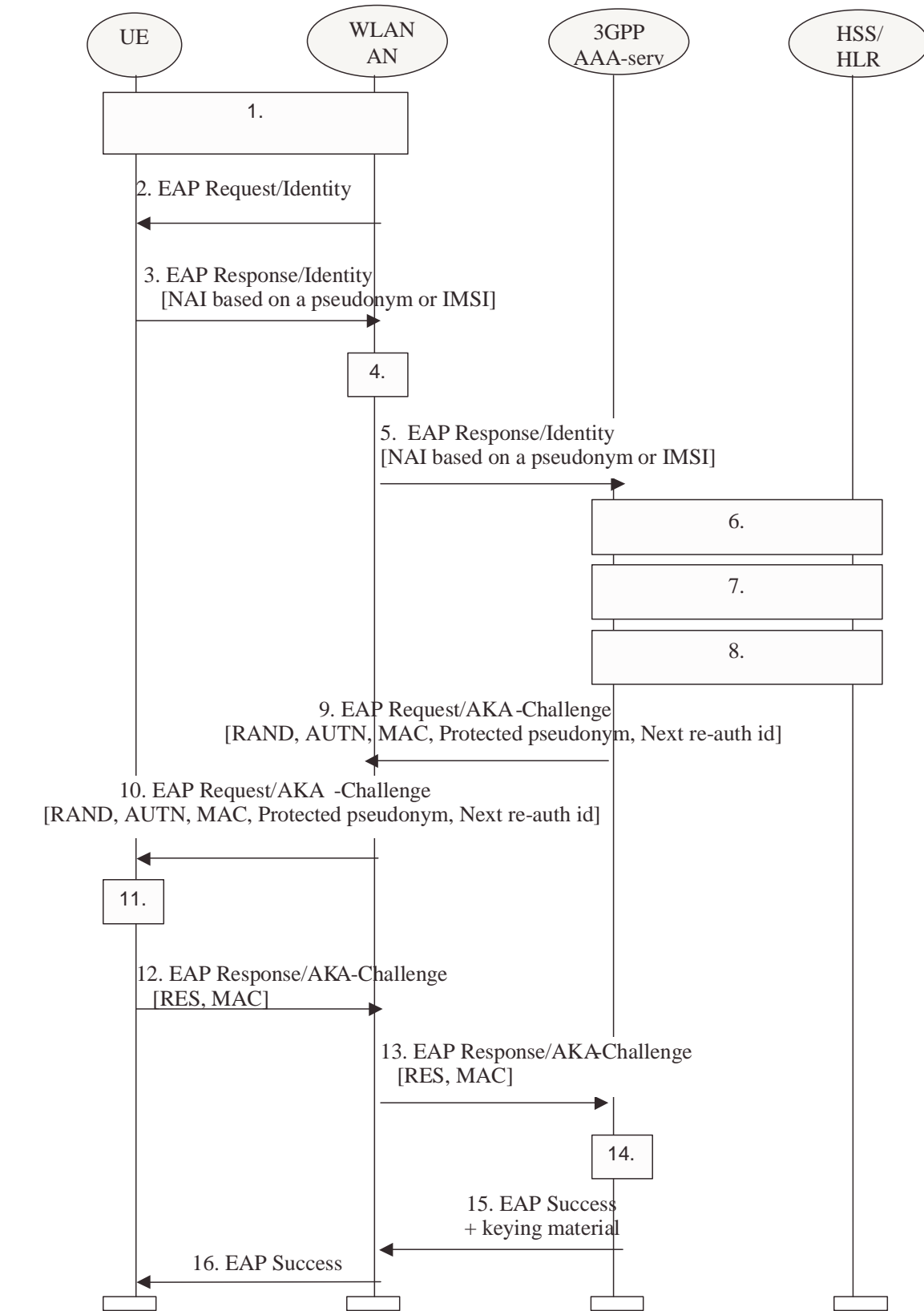

Figure 7.1: Authentication based on EAP AKA scheme

1. A connection is established between the WLAN-UE and the WLAN-AN, using a Wireless LAN technology specific procedure (out of scope for this specification).
2. The WLAN-AN sends an EAP Request/Identity to the WLAN-UE.
EAP packets are transported over the Wireless LAN interface encapsulated within a Wireless LAN technology specific protocol.
3. The WLAN-UE sends an EAP Response/Identity message. The WLAN-UE sends its identity complying with Network Access Identifier (NAI) format specified in RFC 2486. NAI contains either a temporary identifier (pseudonym) allocated to WLAN-UE in previous authentication or, in the case of first authentication, the IMSI.
NOTE: Generating an identity conforming to NAI format from IMSI is defined in EAP/AKA [4]
4. The message is routed towards the proper 3GPP AAA Server based on the realm part of the NAI. The routing path may include one or several AAA proxies (not shown in the figure).
NOTE: Diameter referral can also be applied to find the AAA server.
5. The 3GPP AAA server receives the EAP Response/Identity packet that contains the subscriber identity.
6. 3GPP AAA Server identifies the subscriber as a candidate for authentication with EAP-AKA, based on the received identity. The 3GPP AAA Server then checks that it has an unused authentication vector available for that subscriber. If not, a set of new authentication vectors is retrieved from HSS/HLR. A mapping from the temporary identifier to the IMSI may be required.
NOTE: It could also be the case that the 3GPP AAA Server first obtains an unused authentication vector for the subscriber and, based on the type of authenticator vector received (i.e. if a UMTS authentication vector is received), it regards the subscriber as a candidate for authentication with EAP-AKA.
7. 3GPP AAA server checks that it has the WLAN access profile of the subscriber available. If not, the profile is retrieved from HSS. 3GPP AAA Server verifies that the subscriber is authorized to use the WLAN service.
Although this step is presented after step 6 in this example, it could be performed at some other point, however before step 14. (This will be specified as part of the Wx interface.)
8. New keying material is derived from IK and CK., cf. [4]. This keying material is required by EAP-AKA, and some extra keying material may also be generated for WLAN technology specific confidentiality and/or integrity protection.
A new pseudonym may be chosen and protected (i.e. encrypted and integrity protected) using EAP-AKA generated keying material..
9. 3GPP AAA Server sends RAND, AUTN, a message authentication code (MAC) and two user identities (if they are generated): protected pseudonym and/or re-authentication id to WLAN-AN in EAP Request/AKA-Challenge message. The sending of the re-authentication id depends on 3GPP operator's policies on whether to allow re-authentication processes or not. It implies that, at any time, the AAA server decides (based on policies set by the operator) to include the re-authentication id or not, thus allowing or disallowing the triggering of the re-authentication process.
10. The WLAN-AN sends the EAP Request/AKA-Challenge message to the WLAN-UE.
11. WLAN-UE runs UMTS algorithm on the USIM. The USIM verifies that AUTN is correct and hereby authenticates the network. If AUTN is incorrect, the terminal rejects the authentication (not shown in this example). If the sequence number is out of synch, terminal initiates a synchronization procedure, c.f. [4]. If AUTN is correct, the USIM computes RES, IK and CK.
Using IK and CK the WLAN-UE checks the received MAC and derives required additional keying material
If a protected pseudonym was received, then the WLAN-UE stores the pseudonym for future authentications.
12. WLAN-UE sends EAP Response/AKA-Challenge containing calculated RES and a new MAC value to WLAN-AN
13. WLAN-AN sends the EAP Response/AKA-Challenge packet to 3GPP AAA Server

14. 3GPP AAA Server checks the received MAC and compares XRES to the received RES.
15. If all checks in step 14 are successful, then 3GPP AAA Server sends the EAP Success message to WLAN-AN. If some extra keying material was generated for WLAN technology specific confidentiality and/or integrity protection then the 3GPP AAA Server includes this keying material in the underlying AAA protocol message (i.e. not at EAP level). The WLAN-AN stores the keying material to be used in communication with the authenticated WLAN-UE.
16. WLAN-AN informs the WLAN-UE about the successful authentication with the EAP Success message. Now the EAP AKA exchange has been successfully completed, and the WLAN-UE and the WLAN-AN share keying material derived during that exchange.

6.1.2 GSM SIM based authentication

SIM based authentication is useful for GSM subscribers that do not have a UICC with a USIM application. This form of authentication shall be based on EAP-SIM (ref. [5]), as described in section 6.1.2.1. This authentication method satisfies the authentication requirements from section 4.2., without the need for a UICC with a USIM application

[Editor's note: also see section 4.2.4 on WLAN UE split]

6.1.2.1 EAP SIM procedure

The EAP-SIM authentication mechanism is specified in ref. [5]. The present section describes how this mechanism is used in the WLAN-3GPP interworking scenario.

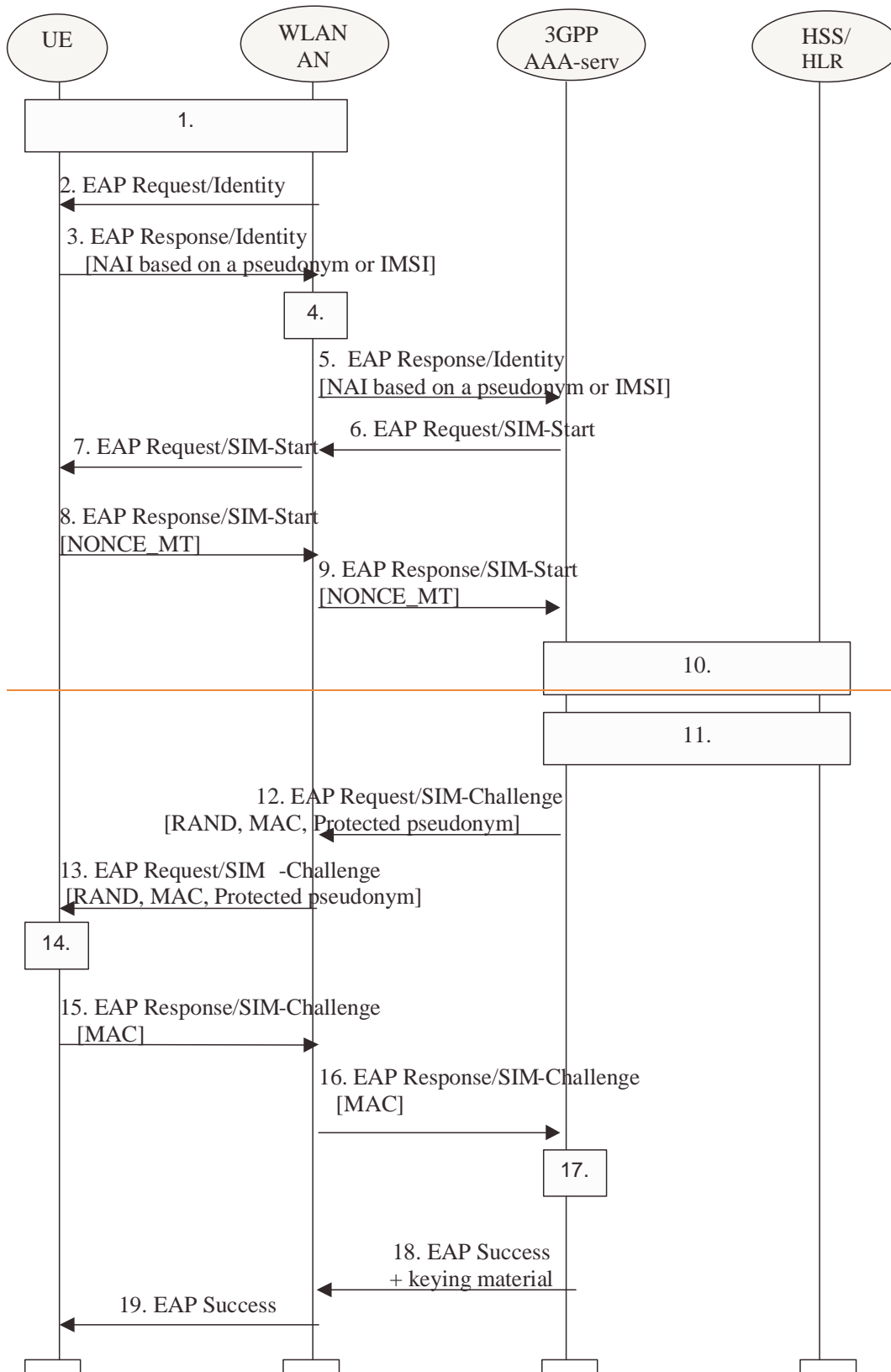

7.2: Authentication based on EAP SIM scheme

1. A connection is established between the WLAN UE and the WLAN AN, using a Wireless LAN technology specific procedure (out of scope for this specification).

~~2. The WLAN-AN sends an EAP Request/Identity to the WLAN-UE.~~

~~— EAP packets are transported over the Wireless LAN interface encapsulated within a Wireless LAN technology specific protocol.~~

~~3. The WLAN-UE sends an EAP Response/Identity message. The WLAN-UE sends its identity complying with the Network Access Identifier (NAI) format specified in RFC 2486. NAI contains either a temporary identifier (pseudonym) allocated to WLAN-UE in previous authentication or, in the case of first authentication, the IMSI.~~

~~NOTE:— Generating an identity conforming to NAI format from IMSI is defined in EAP/SIM.~~

~~4. The message is routed towards the proper 3GPP AAA Server based on the realm part of the NAI. The routing path may include one or several AAA proxies (not shown in the figure).~~

~~NOTE:— Diameter referral can also be applied to find the AAA server.~~

~~5. The 3GPP AAA server receives the EAP Response/Identity packet that contains the subscriber identity.~~

~~6. The 3GPP AAA Server, identifies the subscriber as a candidate for authentication with EAP-SIM, based on the received identity, , and then it sends the EAP Request/SIM-Start packet to WLAN-AN.~~

~~NOTE:— It could also be the case that the 3GPP AAA Server first obtains an authentication vector for the subscriber and, based on the type of authenticator vector received (i.e. if a GSM authentication vector is received), it regards the subscriber as a candidate for authentication with EAP-SIM.~~

~~7. WLAN-AN sends the EAP Request/SIM-Start packet to WLAN-UE~~

~~8. The WLAN-UE chooses a fresh random number NONCE_MT. The random number is used in network authentication.~~

~~— The WLAN-UE sends the EAP Response/SIM-Start packet, containing NONCE_MT, to WLAN-AN.~~

~~9. WLAN-AN sends the EAP Response/SIM-Start packet to 3GPP AAA Server~~

~~10. The AAA server checks that it has available N unused authentication vectors for the subscriber. Several GSM authentication vectors are required in order to generate keying material with effective length equivalent to EAP-AKA.. If N authentication vectors are not available, a set of authentication t vectors is retrieved from HSS/HLR. A mapping from the temporary identifier to the IMSI may be required.~~

~~— Although this step is presented after step 9 in this examples, it could be performed at some other point, for example after step 5, however before step 12. (This will be specified as part of the Wx interface.)~~

~~11. The AAA server checks that it has the WLAN access profile of the subscriber available. If not, the profile is retrieved from HSS/HLR. 3GPP AAA Server verifies that the subscriber is authorized to use the WLAN service.~~

~~— Although this step is presented after step 10 in this example, it could be performed at some other point, however before step 18. (This will be the specified as part of the Wx interface).~~

~~12. New keying material is derived from NONCE_MT and N Ke keys. This keying material is required by EAP-SIM, and some extra keying material may also be generated for WLAN technology specific confidentiality and/or integrity protection.~~

~~— A new pseudonym may be chosen and protected (i.e. encrypted and integrity protected) using EAP-SIM generated keying material.~~

~~— A message authentication code (MAC) is calculated over the EAP message using an EAP-SIM derived key. This MAC is used as a network authentication value.~~

~~— 3GPP AAA Server sends RAND, MAC, and protected pseudonym (in case it was generated) WLAN-AN in EAP Request/SIM-Challenge message.~~

~~13. The WLAN sends the EAP Request/SIM-Challenge message to the WLAN-UE.~~

~~14. WLAN-UE runs N times the GSM A3/A8 algorithms in the SIM, once for each received RAND.~~

~~— This computing gives N SRES and Ke values.~~

- ~~—The WLAN UE derives additional keying material from N-K_e keys and NONCE_{MT}.~~
 - ~~—The WLAN UE calculates its copy of the network authentication MAC and checks that it is equal with the received MAC. If the MAC is incorrect, the network authentication has failed and the WLAN UE cancels the authentication (not shown in this example). The WLAN UE continues the authentication exchange only if the MAC is correct.~~
 - ~~—WLAN UE calculates a new MAC covering the EAP message concatenated to the N-SRES responses.~~
 - ~~—If a protected pseudonym was received, then the WLAN UE stores the pseudonym for future authentications.~~
 - ~~15. WLAN UE sends EAP Response/SIM Challenge containing calculated MAC to WLAN AN.~~
 - ~~16. WLAN AN sends the EAP Response/SIM Challenge packet to 3GPP AAA Server.~~
 - ~~17. 3GPP AAA Server compares its copy of the response MAC with the received MAC.~~
 - ~~18. If the comparison in step 17 is successful, then 3GPP AAA Server sends the EAP Success message to WLAN AN. If some extra keying material was generated for WLAN technology specific confidentiality and/or integrity protection, then the 3GPP AAA Server includes this derived keying material in the underlying AAA protocol message. (i.e. not at EAP level). The WLAN AN stores the keying material to be used in communication with the authenticated WLAN UE.~~
 - ~~19. WLAN AN informs the WLAN UE about the successful authentication with the EAP Success message. Now the EAP SIM exchange has been successfully completed, and the WLAN UE and the WLAN AN may share keying material derived during that exchange.~~
- ~~NOTE:—The derivation of the value of N is for further study.~~

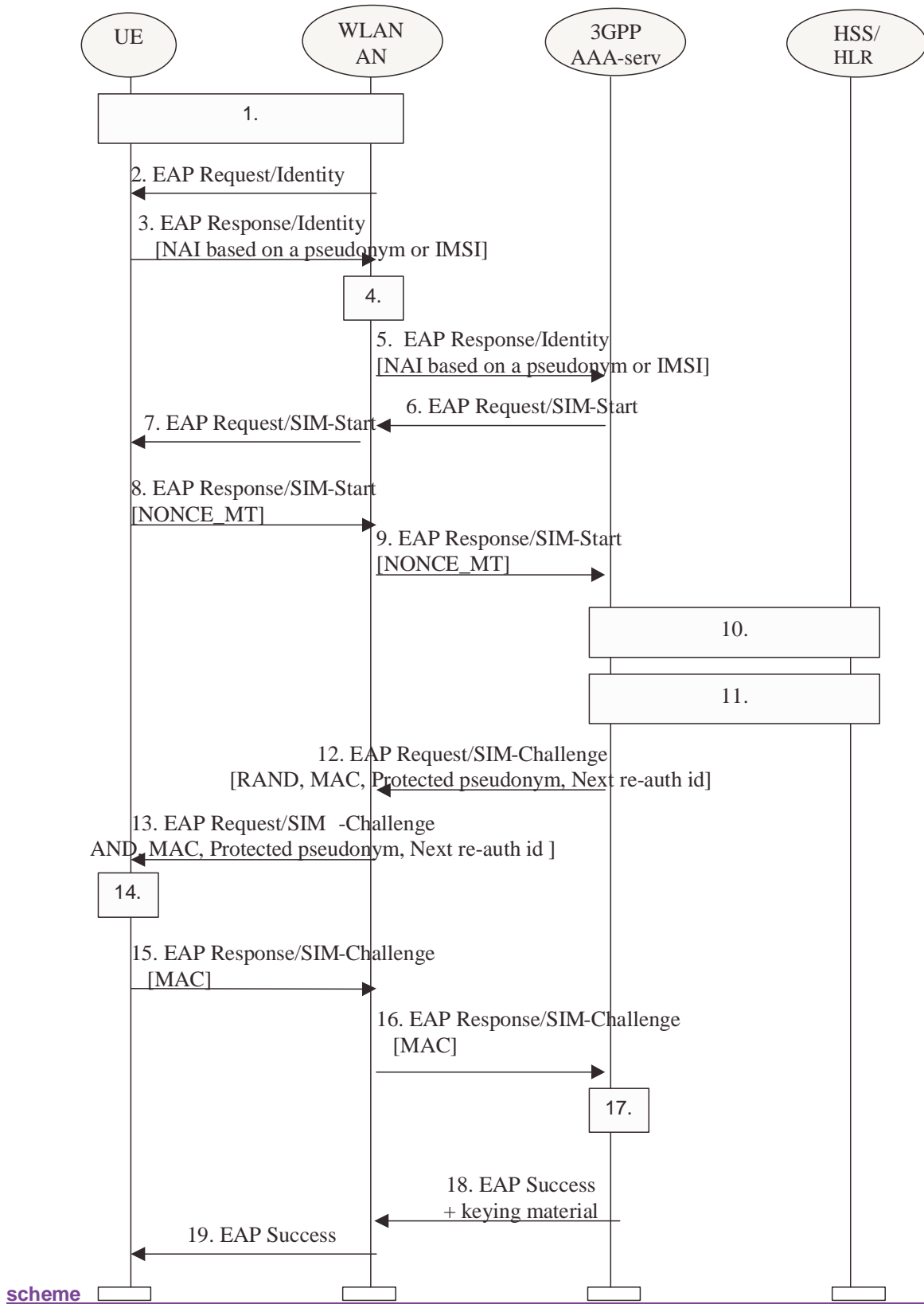

1. A connection is established between the WLAN-UE and the WLAN-AN, using a Wireless LAN technology specific procedure (out of scope for this specification).

2. The WLAN-AN sends an EAP Request/Identity to the WLAN-UE.

EAP packets are transported over the Wireless LAN interface encapsulated within a Wireless LAN technology specific protocol.

3. The WLAN-UE sends an EAP Response/Identity message. The WLAN-UE sends its identity complying with the Network Access Identifier (NAI) format specified in RFC 2486. NAI contains either a temporary identifier (pseudonym) allocated to WLAN-UE in previous authentication or, in the case of first authentication, the IMSI.

NOTE: Generating an identity conforming to NAI format from IMSI is defined in EAP/SIM.

4. The message is routed towards the proper 3GPP AAA Server based on the realm part of the NAI. The routing path may include one or several AAA proxies (not shown in the figure).

NOTE: Diameter referral can also be applied to find the AAA server.

5. The 3GPP AAA server receives the EAP Response/Identity packet that contains the subscriber identity.

6. The 3GPP AAA Server, identifies the subscriber as a candidate for authentication with EAP-SIM, based on the received identity, and then it sends the EAP Request/SIM-Start packet to WLAN-AN.

NOTE: It could also be the case that the 3GPP AAA Server first obtains an authentication vector for the subscriber and, based on the type of authenticator vector received (i.e. if a GSM authentication vector is received), it regards the subscriber as a candidate for authentication with EAP-SIM.

7. WLAN-AN sends the EAP Request/SIM-Start packet to WLAN-UE

8. The WLAN-UE chooses a fresh random number NONCE_{MT}. The random number is used in network authentication.

The WLAN-UE sends the EAP Response/SIM-Start packet, containing NONCE_{MT}, to WLAN-AN.

9. WLAN-AN sends the EAP Response/SIM-Start packet to 3GPP AAA Server

10. The AAA server checks that it has available N unused authentication vectors for the subscriber. Several GSM authentication vectors are required in order to generate keying material with effective length equivalent to EAP-AKA. If N authentication vectors are not available, a set of authentication vectors is retrieved from HSS/HLR. A mapping from the temporary identifier to the IMSI may be required.

Although this step is presented after step 9 in this examples, it could be performed at some other point, for example after step 5, however before step 12. (This will be specified as part of the Wx interface.)

11. The AAA server checks that it has the WLAN access profile of the subscriber available. If not, the profile is retrieved from HSS/HLR. 3GPP AAA Server verifies that the subscriber is authorized to use the WLAN service.

Although this step is presented after step 10 in this example, it could be performed at some other point, however before step 18. (This will be specified as part of the Wx interface).

12. New keying material is derived from NONCE_{MT} and N_{Kc} keys. This keying material is required by EAP-SIM, and some extra keying material may also be generated for WLAN technology specific confidentiality and/or integrity protection.

A new pseudonym and/or a re-authentication identity may be chosen and protected (i.e. encrypted and integrity protected) using EAP-SIM generated keying material.

A message authentication code (MAC) is calculated over the EAP message using an EAP-SIM derived key. This MAC is used as a network authentication value.

3GPP AAA Server sends RAND, MAC, protected pseudonym and re-authentication identity (the two latter in case they were generated) to WLAN-AN in EAP Request/SIM-Challenge message. The sending of the re-authentication id depends on 3GPP operator's policies on whether to allow re-authentication processes or not. It implies that, at any time, the AAA server decides (based on policies set by the operator) to include the re-authentication id or not, thus allowing or disallowing the triggering of the re-authentication process.

13. The WLAN sends the EAP Request/SIM-Challenge message to the WLAN-UE.

14. WLAN-UE runs N times the GSM A3/A8 algorithms in the SIM, once for each received RAND.

This computing gives N SRES and Kc values.

The WLAN-UE derives additional keying material from N Kc keys and NONCE_MT.

The WLAN-UE calculates its copy of the network authentication MAC and checks that it is equal with the received MAC. If the MAC is incorrect, the network authentication has failed and the WLAN-UE cancels the authentication (not shown in this example). The WLAN-UE continues the authentication exchange only if the MAC is correct.

WLAN-UE calculates a new MAC covering the EAP message concatenated to the N SRES responses.

If a protected pseudonym was received, then the WLAN-UE stores the pseudonym for future authentications.

15. WLAN-UE sends EAP Response/SIM-Challenge containing calculated MAC to WLAN-AN.

16. WLAN-AN sends the EAP Response/SIM-Challenge packet to 3GPP AAA Server.

17. 3GPP AAA Server compares its copy of the response MAC with the received MAC.

18. If the comparison in step 17 is successful, then 3GPP AAA Server sends the EAP Success message to WLAN-AN. If some extra keying material was generated for WLAN technology specific confidentiality and/or integrity protection, then the 3GPP AAA Server includes this derived keying material in the underlying AAA protocol message. (i.e. not at EAP level). The WLAN-AN stores the keying material to be used in communication with the authenticated WLAN-UE.

19. WLAN-AN informs the WLAN-UE about the successful authentication with the EAP Success message. Now the EAP SIM exchange has been successfully completed, and the WLAN-UE and the WLAN-AN may share keying material derived during that exchange.

NOTE: The derivation of the value of N is for further study.

6.1.3 EAP support in Smart Cards

[Editors note LS (S3-030187/ S1-030546) from SA1 has stated that "There are requests from operators for a secure SIM based WLAN authentication solution". SA3 has SA1 in an LS (S3-030306) if this request is confirmed. The input paper to SA3 on this can be found at:

http://www.3gpp.org/ftp/tsg_sa/WG3_Security/TSGS3_28_Berlin/Docs/ZIP/S3-030198.zip]

6.1.4 Re-authentication mechanisms

~~[Editor's note: This section shall describe the mechanisms to support the re-authentication feature described in 5.1.7]~~

When authentication processes have to be performed frequently, it can lead to a high network load specially when the number of connected users is high. Then it is more efficient to perform re-authentications. Thus the re-authentication process allows the WLAN-AN to authenticate a certain user in a lighter process than a full authentication, thanks to the re-use of the keys derived on the previous full authentication.

6.1.4.1. EAP/AKA procedure

The implementation of EAP/AKA must include the re-authentication mechanism described in this chapter, although its use is optional and depends on operator's policies. The complete procedure is defined in ref [4]. In this section it is described how the process works for WLAN-3GPP interworking.

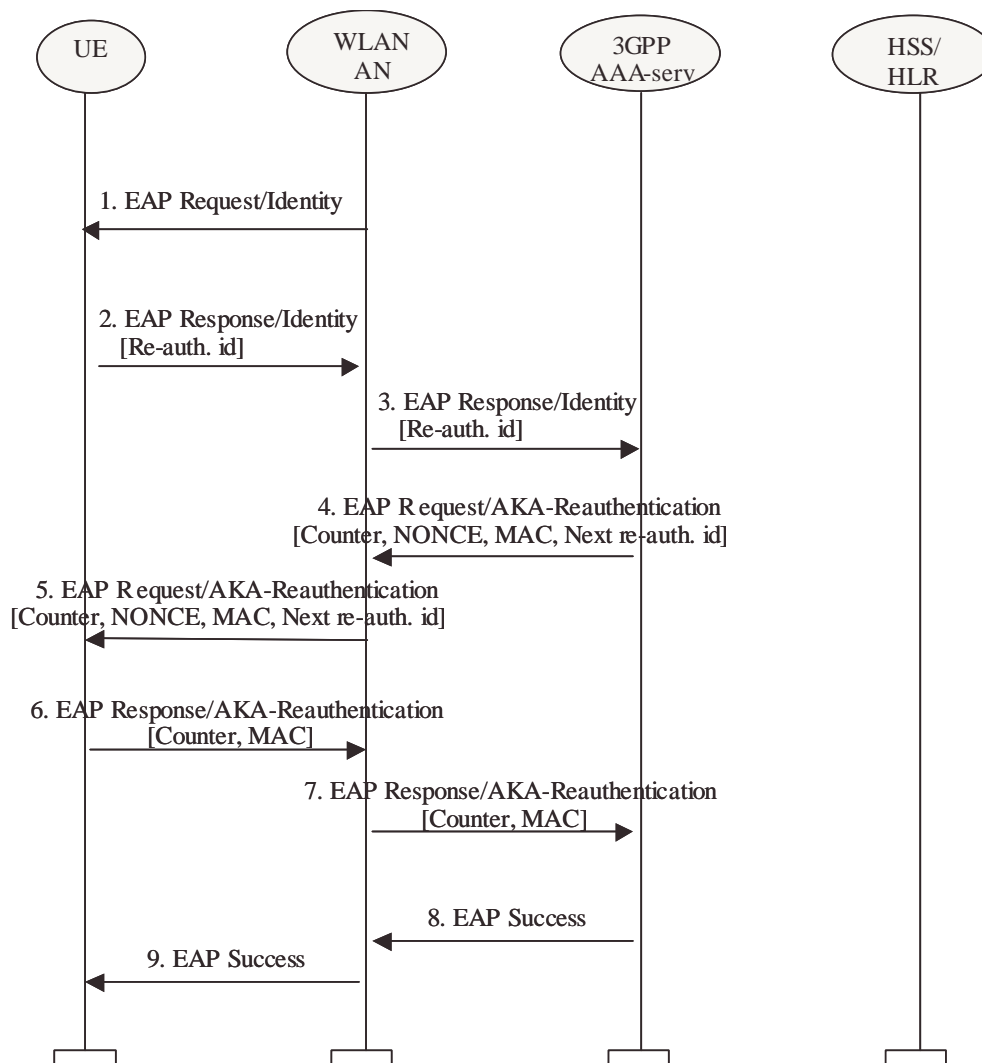

Figure 7.3 : EAP AKA Re-authentication

1. WLAN-AN sends an EAP Request/Identity to the WLAN-UE
2. WLAN-UE replies with an EAP Response/Identity containing a re-authentication identity (this identity was previously delivered by AAA server in a full authentication procedure). The WLAN-UE can take the decision of not performing a re-authentication but a full authentication. In that case, it will include a pseudonym in the message to the WLAN AN and a normal authentication process will take place.
3. The WLAN-AN forwards the EAP Response/Identity to the AAA server.
4. The AAA server initiates the Counter (which was initialized to one in the full authentication process) and sends it in the EAP Request message, together with the NONCE, the MAC (calculated over the NONCE) and a re-authentication id for a next re-authentication. If the AAA server is not able to deliver a re-authentication identity, next time the WLAN-UE will force a full-authentication (to avoid the use of the re-authentication identity more than once).
5. The WLAN-AN forwards the EAP Request message to the WLAN-UE

6. The WLAN-UE verifies that the Counter value is fresh and the MAC is correct, and it sends the EAP Response message with the same Counter value (it is up to the AAA server to step it up) and a calculated MAC.
7. The WLAN-AN forwards the response to the AAA server
8. The AAA server verifies that the Counter value is the same as it sent, and the MAC is correct, and sends an EAP Success message
9. The EAP Success message is forwarded to the WLAN-UE.

6.1.4.2. EAP/SIM procedure

The implementation of EAP/SIM must include the re-authentication mechanism described in this chapter, although its use is optional and depends on operator's policies. The complete procedure is defined in ref [4]. In this section it is described how the process works for WLAN-3GPP interworking.

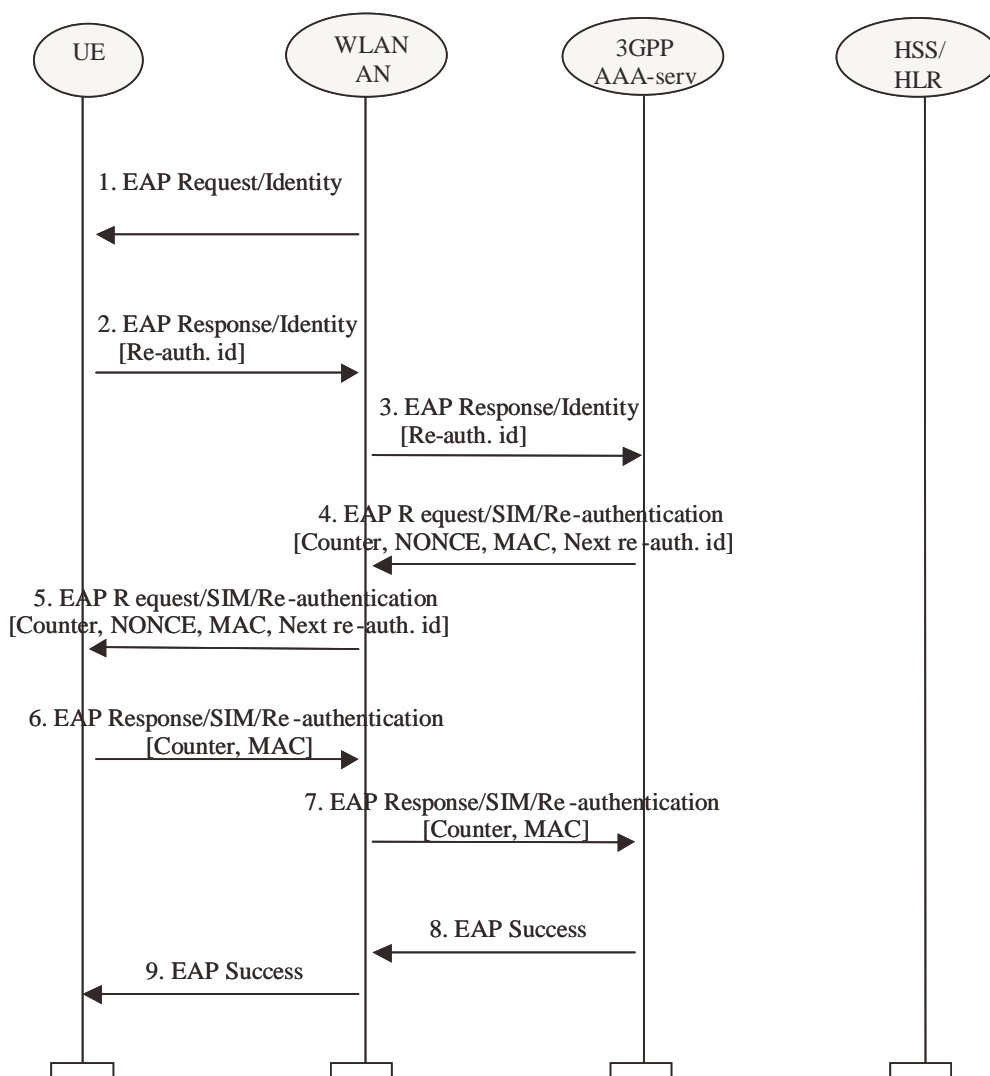

Figure 7.4 : EAP SIM Re-authentication

1. WLAN-AN sends an EAP Request/Identity to the WLAN-UE
2. WLAN-UE replies with an EAP Response/Identity containing a re-authentication identity (this identity was previously delivered by AAA server in a full authentication procedure). The WLAN-UE can take the decision of not performing a re-authentication but a full authentication. In that case, it will include a pseudonym in the message to the WLAN AN and a normal authentication process will take place.
3. The WLAN-AN forwards the EAP Response/Identity to the AAA server.
4. The AAA server initiates the Counter (which was initialized to one in the full authentication process) and sends it in the EAP Request message, together with the NONCE, the MAC (calculated over the NONCE) and a re-authentication id for a next re-authentication. If the AAA server is not able to deliver a re-authentication identity, next time the WLAN-UE will force a full-authentication (to avoid the use of the re-authentication identity more than once).
5. The WLAN-AN forwards the EAP Request message to the WLAN-UE
6. The WLAN-UE verifies that the Counter value is fresh and the MAC is correct, and it sends the EAP Response message with the same Counter value (it is up to the AAA server to step it up) and a calculated MAC.
7. The WLAN-AN forwards the response to the AAA server
8. The AAA server verifies that the Counter value is the same as it sent, and the MAC is correct, and sends an EAP Success message
9. The EAP Success message is forwarded to the WLAN-UE.

6.2 Confidentiality mechanisms

[Editor's note: This section shall deal with cipher algorithms]

6.3 Integrity mechanisms

[Editor's note: This section shall deal with integrity algorithms]

6.4 Temporary identity management

6.4.1 Pseudonym Generation

Pseudonyms are generated as some form of encrypted IMSI. Advanced Encryption Standard (AES) (see ref. [17]) in Electronic Codebook (ECB) mode of operation with 128-bit keys is used for this purpose.

In order to encrypt with AES in ECB mode, it is necessary that the length of the clear text is a multiple of 16 octets. This clear text is formed as follows:

1. A *Compressed IMSI* is created utilising 4 bits to represent each digit of the IMSI. According to ref. [18], the length of the IMSI is not more than 15 digits (numerical characters, 0 through 9). The length of the *Compressed IMSI* shall be 64 bits (8 octets), and the most significant bits will be padded by setting all the bits to 1.

E.g.: IMSI = 214070123456789 (MCC = 214 ; MNC = 07 ; MSIN = 0123456789)

Compressed IMSI = 0xF2 0x14 0x07 0x01 0x23 0x45 0x67 0x89

Observe that, at reception of a pseudonym, it is easy to remove the padding of the *Compressed IMSI* as none of the IMSI digits will be represented with 4 bits set to 1. Moreover, a sanity check should be done at reception of a pseudonym, by checking that the padding, the MCC and the MNC are correct, and that all characters are digits.

2. A *Padded IMSI* is created by concatenating an 8-octet random number to the *Compressed IMSI*.

A 128-bit secret key, K_{pseu} , is used for the encryption. The same secret key must be configured at all the WLAN AAA servers in the operator network so that any WLAN AAA server can obtain the permanent identity from a pseudonym generated at any other WLAN AAA server (see section 6.4.2).

The figure below summarises how the *Encrypted IMSI* is obtained.

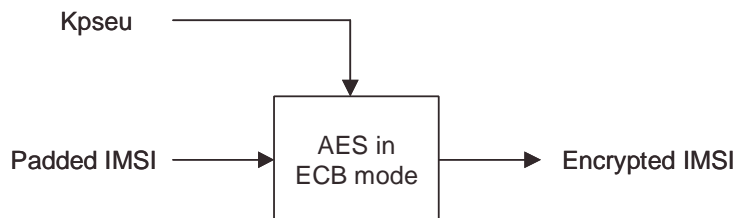

Once the *Encrypted IMSI* has been generated, the following fields are concatenated:

- *Encrypted IMSI*, so that a AAA server can later obtain the IMSI from the pseudonym.
- *Key Indicator*, so that the AAA server that receives the pseudonym can locate the appropriate key to de-encrypt the Encrypted IMSI. (See section 6.4.2.)
- *Pseudonym Tag*, used to mark the identity as a pseudonym. The tag should be different for pseudonyms generated for EAP-SIM and for EAP-AKA.

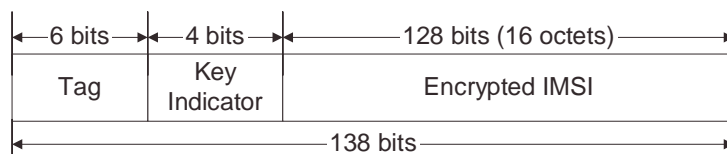

The *Pseudonym Tag* is necessary so that when a WLAN AAA receives a user identity it can determine whether to process it as a permanent or a temporary user identity. Moreover, according to EAP-SIM/AKA specifications, when the Authenticator node (i.e. the AAA server) receives a temporary user identity from which a permanent user identity cannot be successfully obtained, then the permanent user identity must be requested from the WLAN client. As the procedure to request the permanent user identity is different in EAP-SIM and EAP-AKA, the *Pseudonym Tag* must be different for EAP-SIM pseudonyms and for EAP-AKA pseudonyms, so that the AAA can determine which procedure to follow.

The last step in the generation of the pseudonym consists on converting the concatenation above to a printable string using the BASE64 method described in section 4.3.2.4 of ref. [16]. With this mechanism, each 6-bit group is used as an index into an array of 64 printable characters. As the length of the concatenation is 138 bits, the length of the resulting pseudonym is 23 characters, and no padding is necessary. Observe that the length of the *Pseudonym Tag* has been chosen to be 6 bits, so that it directly translates into one printable character after applying the transformation. Therefore, at reception of a user identity, the AAA server can recognise that it is a pseudonym for EAP-SIM or a pseudonym for EAP-AKA without performing any reverse transformation (i.e. without translating any printable character into the corresponding 6 bits).

6.4.2 Key Management

A 128-bit encryption key shall be used for the generation of pseudonyms for a given period of time determined by the operator. Once that time has expired, a new key shall be configured at all the WLAN AAA servers. The old key shall not be used any longer for the generation of pseudonyms, but the AAA servers must keep a number of suspended (old) keys for the interpretation of received pseudonyms that were generated with those old keys. The number of suspended keys kept in the AAA servers (up to 16) should be set by the operator, but it must be at least one, in order to avoid that a just-generated pseudonym becomes invalid immediately due to the expiration of the key.

Each key must have associated a Key Indicator value. This value is included in the pseudonym (see *Key Indicator* field in section 6.4.1), so that when a WLAN AAA receives the pseudonym, it can use the corresponding key for obtaining the *Padded IMSI* (and thence the Username).

If a pseudonym is sent to a WLAN client but then the user does not initiate new authentication attempts for a long period of time, the key used for the generation of that pseudonym could eventually be removed from all the WLAN AAA servers. If the user initiates an authentication attempt after that time using that old pseudonym, the receiving AAA server will not be able to recognise the pseudonym as a valid one, and it will request the permanent user identity from the WLAN client. Hence, in order to achieve that permanent user identities are used as little as possible, it is recommended that the encryption key is not renewed very often.

The configuration of the keys could be done via O&M, as shown in the figure below.

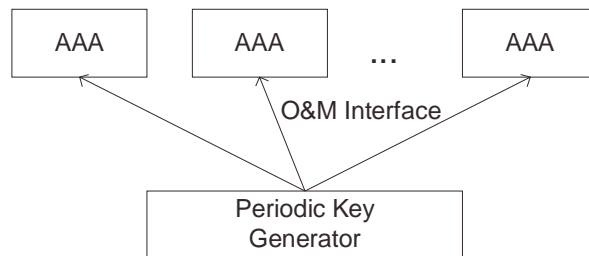

Handling of these secret keys, including generation, distribution and storage, should be done in a secure way.

6.4.3 Impact on Permanent User Identities

User identities (permanent or temporary) are sent with the form of a NAI, according to the EAP-SIM/AKA specifications, and the maximum length of a NAI that we can expect to be handled correctly by standard equipment is 72 octets (see ref. [14]). Moreover, this NAI will be transported inside the User-Name attribute of a RADIUS Access-Request, with standard length up to 63 octets (see ref. [15]). Therefore, it can be assumed that the maximum length of a WLAN user identity should be 63 octets (i.e. 63 characters).

Since the length of the pseudonym proposed in section 6.4.1 is 23 characters, the length of the realm part of any WLAN permanent user identity must always be 40 characters or less. This applies regardless of whether the length of the username part of the permanent user identity is less than 23 characters. (Note that a WLAN temporary user identity is formed as a NAI with the pseudonym as the username part and the same realm part as the permanent user identity.)

Moreover, the WLAN permanent user identities should not begin with the character resulting of the printable encoding transformation (see section 6.4.1) of the *Pseudonym Tag* used for EAP-SIM and EAP-AKA pseudonyms. This is needed so that at reception of a WLAN user identity, the AAA server can determine whether it is a permanent or a temporary user identity.

6.4.4 Acknowledged Limitations

This mechanism does not prevent forging of pseudonyms generated with keys that are no longer maintained in the AAA servers. That is, an attacker may form a pseudonym by concatenating the desired *Pseudonym Tag* and 132 bits of random information, and then applying the printable encoding transformation (see section 6.4.1). At reception of such pseudonym in a AAA server, the following cases are possible:

- The *Key Indicator* may not correspond to any key (active or suspended) maintained at the AAA server.
- If the *Key Indicator* corresponds to any of the keys maintained at the AAA server, then that key is used for the de-encryption of the *Encrypted IMSI*, but the sanity check over the padding, the MCC and the MNC would show that the IMSI is not correct.

In any case, the AAA server must interpret that the received pseudonym was generated with a key that is no longer available, and therefore it must request the permanent user identity to the WLAN client.

This could be exploited to perform DoS attacks by initiating a large amount of authentication attempts presenting different forged temporary identities. Nonetheless, the consequences of this attack should not be worse than the already possible attack of initiating a large amount of authentication attempts presenting different forged permanent identities.

6.4.5 UE behaviour on receiving requests to send the IMSI-based user identity

When the 3GPP AAA server does not recognize a temporary identifier used by the UE, the 3GPP AAA server requests the UE to send the IMSI-based user identity. The UE can operate according to one of the following three alternatives.

1. Ignore the Request: This alternative may result in deadlock situations that prevent the UE from connecting to a valid network. If this alternative is implemented, then there must be a separate mechanism available for the user to override the policy (for example to delete the stored temporary identifier, which would result in using the IMSI-based identity upon the next connection).
2. Prompt the User: In this alternative, the UE prompts the user during the EAP authentication whether to send the IMSI-based identity to the network. If the user denies sending the IMSI, then the authentication exchange is cancelled.
3. Always Send the IMSI-Based Identity: In alternative #3, the UE always sends the IMSI-based identity when requested.

The decision is UE specific and outside the scope of this specification.

Annex A (informative): Review of the security of existing WLAN-related technologies

A.1 IEEE

A.1.1 IEEE 802 Project

IEEE Project 802 develops LAN and MAN standards, mainly for the lowest 2 layers of the OSI Reference Model. IEEE 802.11 is the Wireless LAN Working Group (WG) within Project 802. The existing 802.11 standard with amendments are:

- 802.11 Wireless LAN Medium Access Control (MAC) and Physical Layer (PHY) specifications.
- 802.11a High-speed Physical Layer in the 5 GHz Band.
- 802.11b Higher-Speed Physical Layer Extension in the 2.4 GHz Band.
- 802.11d Specification for operation in additional regulatory domains.

Currently there are a number of Task Groups (TG) in the 802.11 WG that each work on new amendments to the standard:

- 802.11e Medium Access Control (MAC) Enhancements for Quality of Service (QoS).
- 802.11f Inter Access Point Protocol (IAPP). (A recommended practice, not a standard).
- 802.11g Higher-Speed Physical Layer Extension in the 2.4 GHz Band.
- 802.11h Spectrum and Power Management extensions in the 5 GHz band in Europe.
- 802.11i Specification for Enhanced Security.

Membership in IEEE 802.11 is individual (i.e. not based on company) and anyone that has been present at a certain number of meetings becomes member in the WG. Membership is required in order to get voting rights and all members have one vote (again, votes are not company based).

A.1.2 Authentication

Legacy 802.11 authentication

The 802.11-1999 authentication mechanism works at the data link layer (MAC layer). Two authentication methods exist, open system authentication and shared key authentication. Open system authentication is in principle a null authentication scheme and accepts anyone that requests authentication.

Shared key authentication is a challenge-response authentication based on a shared secret. The mobile station sends an Authentication request to the Access Point (AP). The Access Point sends a chosen plaintext string to the station and the station responds with the WEP-encrypted string. (See below for more details on WEP). If the string is correctly encrypted the AP sends an Authentication message to the station to indicate that the authentication was successful. The standard allows for up to four keys in a cell but in practice all communication parties in the cell share the same secret. Note that the authentication is not mutual, only the mobile terminals are authenticated. Shared key authentication is very weak. An attacker that listens to a successful authentication exchange will have all elements that are needed to successfully perform an authentication of his/her own, even if the shared key is unknown. Today shared key authentication is not considered useful.

IEEE 802.1X and EAP

The 802.11i Task Group (TGi) within IEEE is working on enhancements to the 802.11 security ref. [6]. It has been decided to use IEEE 802.1X as the authentication framework ref. [19]. IEEE 802.1X in turn uses the Extensible Authentication Protocol (EAP) that allows for end-to-end mutual authentication between a Mobile Station and an Authentication Server (see ref. [3]). Thus, even though 802.11i still performs access control on layer 2, the authentication message exchange is not restricted to the MAC layer but uses other IEEE standard as well as IETF standards.

IEEE 802.1X is a standard for port-based access control. IEEE 802.1X can be described to lie between the MAC layer and higher layers and takes care of filtering of frames to/from non-authenticated stations. Before authentication is completed only EAP-traffic is allowed to pass. This allows an authentication exchange to cross the Access Point before general data is allowed to pass. When the 802.1X entity in the Access Point (AP) is informed that a mobile station has successfully authenticated, the AP starts to forward data packets to/from that station.

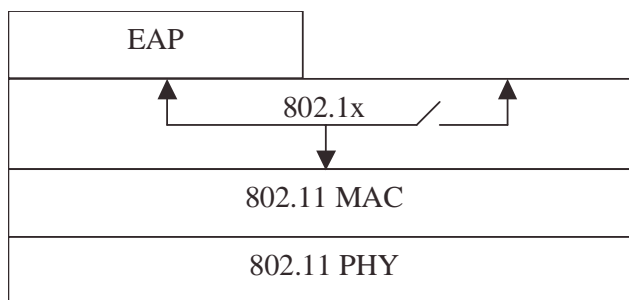

Figure A.1: IEEE 802.1X in part of protocol stack in Access Point or mobile station. EAP messages are always accepted while other packets are filtered based on authentication status

EAP allows for end-to-end authentication between a Mobile Station and an Authentication Server (AS). EAP is a generic protocol that allows different authentication mechanisms (called EAP methods) to be transported. EAP has a general part that describes the general packet format and header content. Each EAP method then has a more specific description for how the actual authentication mechanism is carried by the EAP packets. The EAP packets can then be transported over different protocols. In 802.1X a special frame format called EAP over LAN (EAPOL) is defined for sending EAP messages over 802 links. This allows EAP messages to be sent over the LAN before higher layer protocols, e.g. IP, have been initiated. Between the Access Point (AP) and the AS, EAP messages are typically encapsulated in an AAA protocol, e.g. in RADIUS or DIAMETER (see figure A.2). It is out of the scope of 802.11i to specify a certain AAA protocol. IEEE 802.11i can in principle also be used without AAA protocol if the EAP method is implemented in the AP.

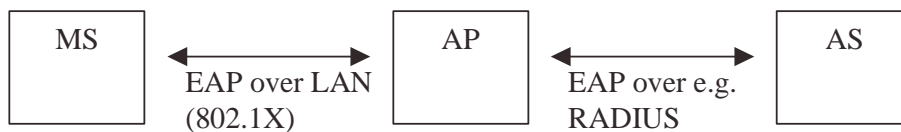

Figure A.2: Example of end-to-end authentication using EAP

Examples of EAP methods (RFCs or Internet Drafts) are:

- EAP-SIM for SIM-based authentication. (Internet Draft) (ref. [5]);
- EAP-AKA for SIM and USIM-based authentication (Internet Draft) (ref. [4]);
- EAP-TLS for certificate-based authentication (RFC) [EAP-TLS] (ref. [7]).

The actual EAP authentication takes place between the MS and the AS and is in principle transparent to the AP. The AP only has to forward EAP messages: EAPOL-encapsulated on the wireless side and e.g. RADIUS-encapsulated on the wired side. If authentication is successful, the AS sends a RADIUS-Access Accept message to the AP (in the case RADIUS is used as AAA protocol). The AP then knows that the MS has been authenticated and can start forwarding traffic to/from the MS. After reception of the Access-Accept message from the AS, the AP sends an EAP-Success message to the MS (see figure A.3).

Key management

To use an EAP method with 802.11i it is required that a 256-bit master key is established as part of the authentication process. Many EAP methods generate key material as part of the authentication (e.g. EAP-SIM, EAP-AKA, EAP-TLS) but the exact way in which the master key is generated depends on the EAP method and is outside the scope of 802.11i. After the EAP authentication is finished, both the MS and the AS will know the master key. If RADIUS is used, the AS then sends the master key to the AP as an attribute in the RADIUS-Access Accept message. The MS and AP use the master key to derive session keys for encryption and integrity protection, as specified in 802.11i. This provides unique unicast keys for each MS-AP association.

The broadcast/multicast key in a cell is generated by the AP and sent in an EAPOL-Key message (defined in 802.1X) to each station. To protect the broadcast/multicast key the EAPOL packet is encrypted with TKIP or AES (see below) using the unicast key. The AP can in principle update the broadcast/multicast key any time, e.g. when a MS leaves the cell.

It shall also be possible to use a pre-shared key instead of the EAP master key material.

Message exchange (example with RADIUS)

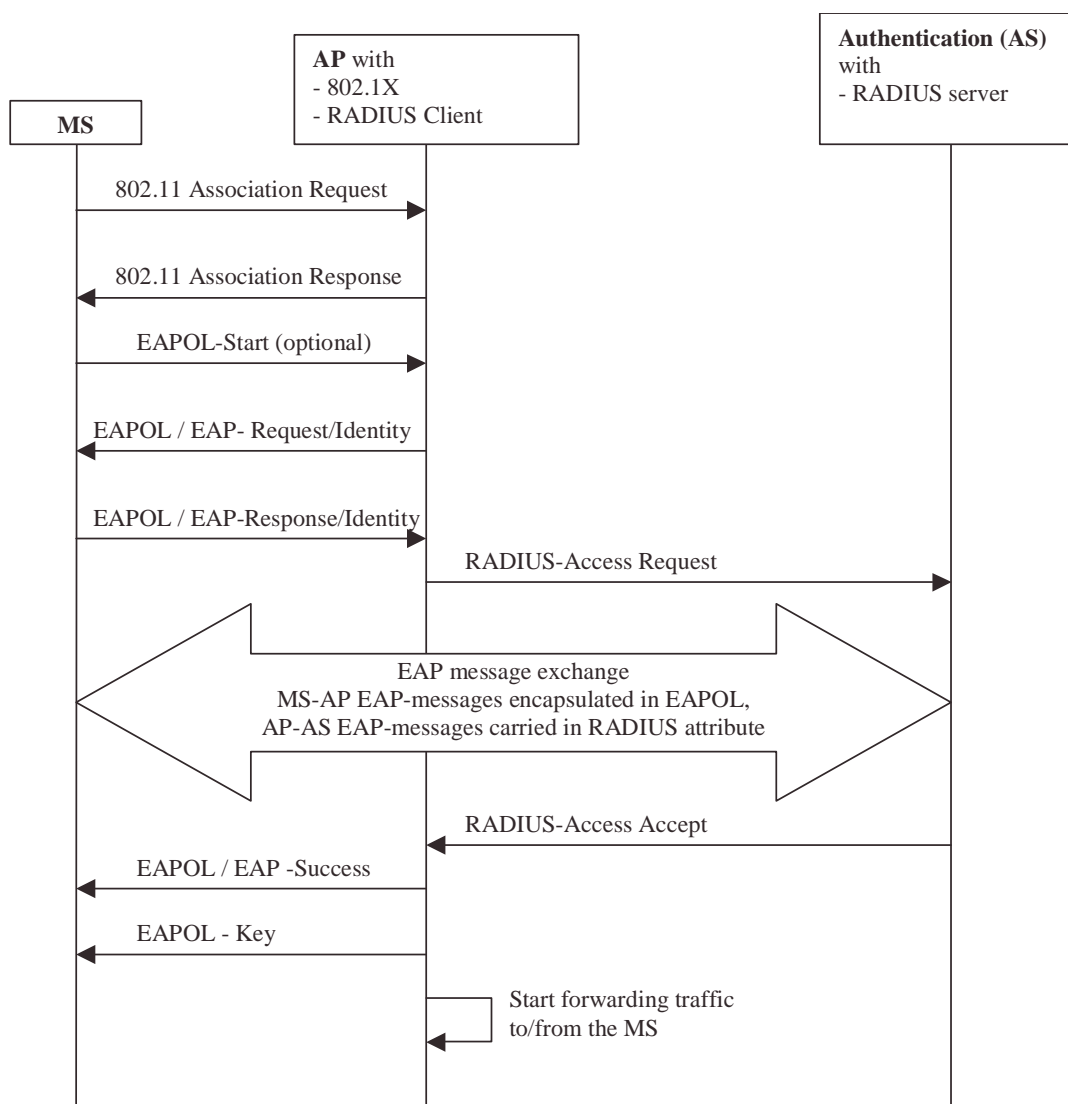

Figure A.3: General EAP authentication with 802.11i and RADIUS as AAA protocol

A.1.3 Encryption and integrity protection

The air-link protection in IEEE 802.11 occurs in the MAC layer. This means that all layer-2 data frames, including LAN broadcasts, are protected. The 802.11-1999 standard specifies the Wired Equivalent Privacy (WEP) for encryption and integrity protection. The 802.11i task group is specifying two new encryption/integrity-protection protocols, the Temporal Key Integrity Protocol (TKIP) and the Wireless Robust Authenticated Protocol (WRAP). The 802.1X/EAP authentication mechanism can in principle be used with any of the three encryption protocols but configuration can restrict the number of allowed encryption protocols in a cell.

In order to be backwards compatible, an 802.11i-capable cell could support several encryption protocols simultaneously. For example, to support legacy stations a manually configured shared WEP key may need to be used for those stations. This key will then also be used as broadcast/multicast key for 802.11i-capable stations that instead use unique pair-wise keys for unicast traffic.

WEP

The IEEE 802.11-1999 Standard specified the Wireless Equivalent Privacy (WEP). WEP uses RC4 with a 40-bit key and 24-bit initialisation vector (IV) for encryption. RC4 is a stream cipher where a seed is used as input to the RC4 PRNG which produces an output bit string that is XOR:ed with the plaintext to produce the ciphertext. For WEP the seed to the RC4 PRNG is the key concatenated with the IV. The key is shared between the communicating parties and the IV is transmitted in clear text in each packet. Message integrity is provided using a CRC checksum that is added to the payload and then encrypted together with the rest of the payload. WEP does not protect against replay.

Since the publication of the standard, several shortcomings of WEP have been discovered. Attacks to retrieve the WEP key and to modify the payload have been described. One weakness is the seed derivation. With RC4 it is important that each packet has a different RC4 seed. The RC4 seed in 802.11-1999 is constructed by concatenating the IV and the 40-bit key but the standard did not contain specifications to ensure uniqueness of <key,IV> pairs.

Today, WEP is not considered useful.

TKIP

The Temporal Key Integrity Protocol (TKIP) is a new protocol that will fix the known problems with WEP. TKIP uses the same ciphering kernel as WEP (RC4) but adds a number of functions:

- 128-bit encryption key.
- 48-bit Initialisation Vector.
- New Message Integrity Code (MIC).
- Initialisation Vector (IV) sequencing rules.
- Per-packet key mixing algorithm that provides a RC4 seed for each packet.
- Active countermeasures.

The purpose of TKIP is to provide a fix for WEP for existing 802.11b products. It is believed that essentially all existing 802.11b products can be software-upgraded with TKIP (all major 802.11 vendors participate in the 802.11i standardisation).

The TKIP MIC was designed with the constraint that it must run on existing 802.11 hardware. It does not offer very strong protection but was considered the best that could be achieved with the majority of legacy hardware. It is based on an algorithm called Michael that is a 64-bit MIC with 20-bit design strength. Details can be found in ref. [6].

The IV sequence is implemented as a monotonically incrementing counter that is unique for each key. This makes sure that each packet is encrypted with a unique <key,IV> pair, i.e. that an IV is not reused for the same key. The receiver shall also use the sequence counter to detect replay attacks. Since frames may arrive out of order due to traffic-class priority values, a replay window (16 packets) has to be used.

A number of "weak" RC4 keys have been identified for which knowledge of a few number of RC4 seed bits makes it possible to determine the initial RC4 output bits to a non-negligible probability. This makes it easier to cryptanalyze data encrypted under these keys. The per-packet mixing function is designed to defeat weak-key attacks. In WEP, the IV and the key are concatenated and then used as seed to RC4. In TKIP, the cryptographic per-packet mixing function combines the key and the IV into a seed for RC4.

Because the TKIP MIC is relatively weak, TKIP uses countermeasures to compensate for this. If the receiver detects a MIC failure, the current encryption and integrity protection keys shall not be used again. To allow a follow-up by a system administrator the event shall be logged. The rate of MIC failure must also be kept below one per minute, which means that new keys shall not be generated if the last key update due to a MIC failure occurred less than a minute ago. In order to minimize the risk of false alarms, the MIC shall be verified after the CRC, IV and other checks have been performed.

TKIP is an interim solution to support 802.11i on legacy hardware. It is not considered as secure as the AES solution (WRAP) but very much better than WEP.

WRAP (AES)

The Wireless Robust Authenticated Protocol (WRAP) is the long-term solution and is based on the Advanced Encryption Standard (AES). AES is a block cipher that can be used in different modes of operation. In 802.11i, two modes have been discussed: Offset Codebook (OCB) and Counter-mode with CBC-MAC (CCM). These two modes use AES differently to provide encryption and message integrity. OCB is a mode that provides both encryption and integrity in one run. CCM uses the Counter-mode for encryption and CBC-MAC for integrity. It is currently undecided if both or only one of the modes will be included in the final 802.11i spec. Both modes have been submitted to NIST as proposed block cipher modes.

The AES implementation requires hardware support and the majority of legacy 802.11b products will thus not be able to run WRAP.

A.2 ETSI/BRAN

A.2.1 HIPERLAN/2 Security architecture

The BRAN Hiperlan/2 (references [9], [10], [11] and [12]) protocol stack consists of a physical layer at the bottom, a DLC layer in the middle, which includes the RLC sub-layer and the convergence layer(s) at the top. The RLC sub-layer is responsible for Radio Resource Control, Association Control and Data Link Control Connection Control. The DLC take cares of error control. Between the RLC and the DLC is the Medium Access Control located per instance of AP, cf. the two figures below.

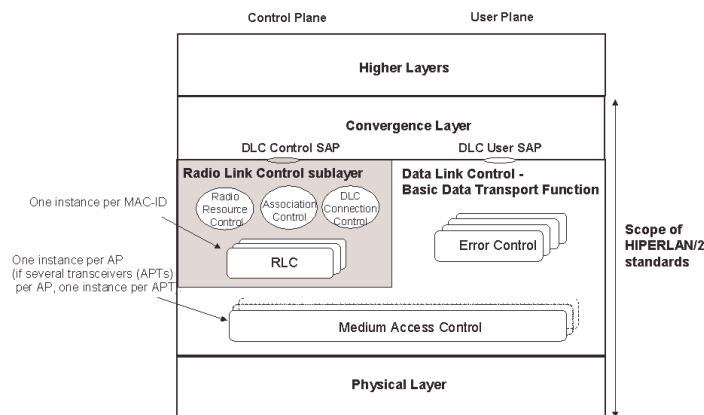

Figure A.4: Protocol stack in the AP/CC

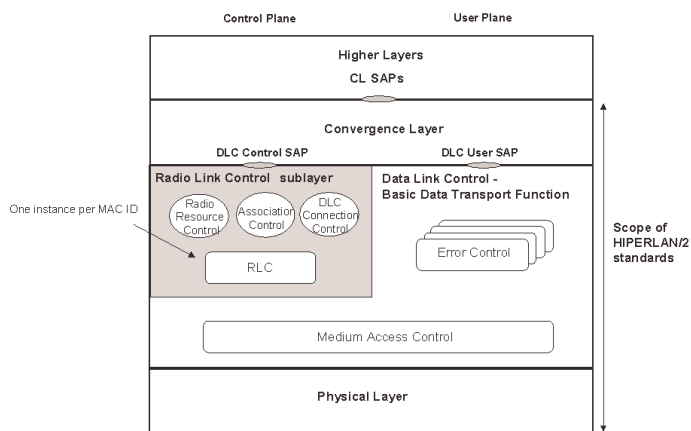

Figure A.5: Protocol stack in the MT

An AP is a device responsible for the centralized control of the resources in a radio cell and is in the most cases connected to a fixed network. A CC is a device that provides with the same functionality as an AP but is not necessarily connected to a fixed network. The term CC is normally used when the central controller and the MT functionality is located in single device.

The Association Control Function performs 1) encryption startup, 2) authentication and 3) DM Common Key Distribution (OMT/OAP) in that order, see figure below.

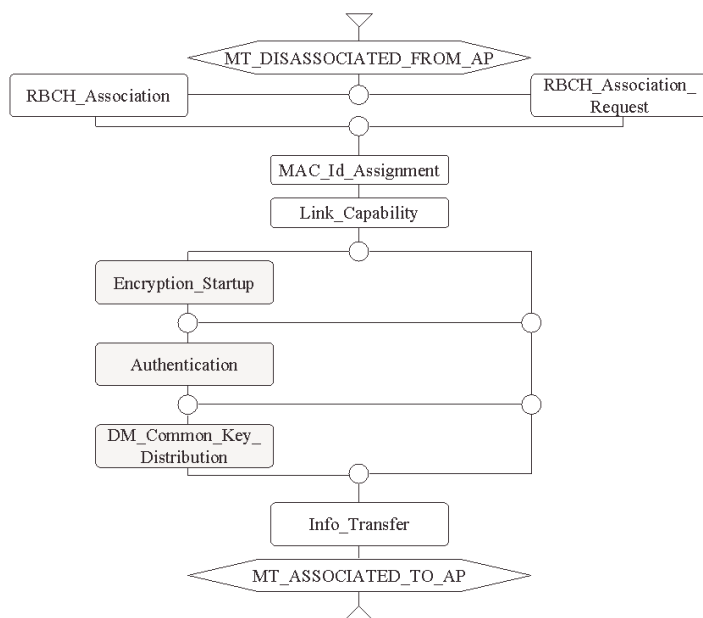

Figure A.6: The Association Control Function

A.2.1.1 Confidentiality protection

Confidentiality protection is provided for user data and part of RLC signalling. The protection can be provided between:

- 1 MT and AP/CC;
- 2 MT and MT (note that the AP has to be trusted).

The following algorithms are defined for confidentiality protection:

- 1 No-encryption;
- 2 DES, Data Encryption Standard;
- 3 Triple-DES (Optional).

A.2.1.2 Authentication

The authentication mechanism provides mutual authentication between the MT and the AP. If the authentication of the MT is successful then access to the connected fixed network is granted. It is the policy of the operator that decides whether authentication of the MT is necessary or not for access.

The authentication of the AP allows the MT to cancel an access attempt if the AP can not be proven to be authentic. The mechanism allows the MT to detect false AP. The authentication protocol is a challenge-response protocol.

Three protocols are defined, based on:

1. Pre-shared keys
 - A pre-shared key shall be at least 128 bits;
2. RSA signatures
 - Three lengths are supported: 512, 768 and 1024 bits (OAP/OMT);
3. No Authentication.

How the keys for the authentication is generated, configured, stored and fetched is out of the scope of the Hiperlan/2 standard.

Each MT will be assigned an authentication key identifier (AKI). The AKI will be sent to the AP with which the MT has a Security Association. There are six different types that can be used:

1. 48-bit IEEE address;
2. 64-bit extended IEEE address;
3. A NAI, Network Access Identifier;
4. Distinguished name;
5. Compressed type which is used when an available AKI is too long to be carried in the RLC messages;
6. Generic type, which is a non-structured octet string.

A.2.1.3 Integrity protection

No integrity mechanism is defined for HIPERLAN/2.

A.2.2 Security mechanisms

A.2.2.1 Confidentiality

Confidentiality protection can be used for Unicast, Multicast and Broadcast scenarios. In order to have Multicast and/or Broadcast confidentiality protection a Unicast encryption has to be established first. The Unicast encryption is optional to use.

The algorithms defined for confidentiality protection are:

- DES which is mandatory to implement for AP/CC and MT;
- Triple-DES (EDE mode) which is optional to implement for AP/CC and MT.

It is possible to provide confidentiality protection for the User Data Channel, User Multicast Channel, User Broadcast Channel, the Dedicated Control Channel and all LCH PDUs except the downlink RLC Broadcast Channel since it has to reach all MT's. The encryption/decryption mechanism is visualized in the figure below.

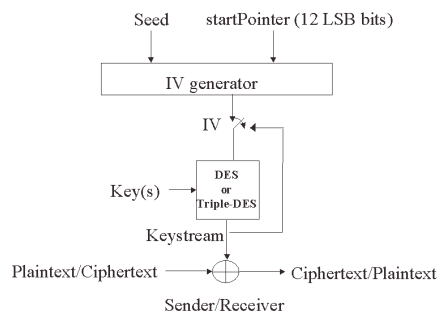

Figure A.7: The encryption/decryption function

Unicast

A Unicast security association is defined between a MT and an AP.

Calculate a Session Secret Key (SSK)

During an Encryption Startup both the MT and the AP calculate a public Diffie-Hellman value and send it to the other party.

This material is used at both sides to calculate an SSK.

Assume that the MT sends $g_x \text{ mod } n$ and the AP sends $g_y \text{ mod } n$ where

$g=2$ the generator of the group

$n=2768-2704-1+264 * \{ [2638\pi] + 149686 \}$, First Oakley Group 1 (768 bit prime)

The AP and the MT now have a shared secret: $g_{xy} \text{ mod } n$, which is the basis for calculating the Session Secret Key.

DES

DES is mandatory to implement.

SSK is defined as the most significant 8 octets defined from KeyMat where:

1. KeyMat=HMAC-MD5($g_{xy} \text{ mod } n$, 0x00)
2. KeyMat=HMAC-MD5($g_{xy} \text{ mod } n$, 0x01)
3. KeyMat=HMAC-MD5($g_{xy} \text{ mod } n$, 0x02)
4. etc.

This process ends when the SSK is found to be a non-weak and a non-semi-weak DES key.

Triple-DES

Triple-DES is optional to implement.

SSK is for this case defined as three keys k_1 , k_2 and k_3 where k_1 is taken from KeyMat= $K_1|K_2$ as the most significant 8 octets, k_2 as the next 8 octets and k_3 as the following 8 octets where:

1. $K_1 = \text{HMAC-MD5}(g_{xy} \text{ mod } n, 0x00)$ & $K_2 = \text{HMAC-MD5}(g_{xy} \text{ mod } n, K_1|0x00)$
2. $K_1 = \text{HMAC-MD5}(g_{xy} \text{ mod } n, 0x01)$ & $K_2 = \text{HMAC-MD5}(g_{xy} \text{ mod } n, K_1|0x01)$

3. $K1 = \text{HMAC-MD5}(\text{gxy mod } n, 0x02)$ & $K2 = \text{HMAC-MD5}(\text{gxy mod } n, K1|0x02)$
4. etc.

Until all three keys $k1$, $k2$ and $k3$ are unequal and that all of them are non-weak and non-semi-weak DES keys.

Multicast and Broadcast

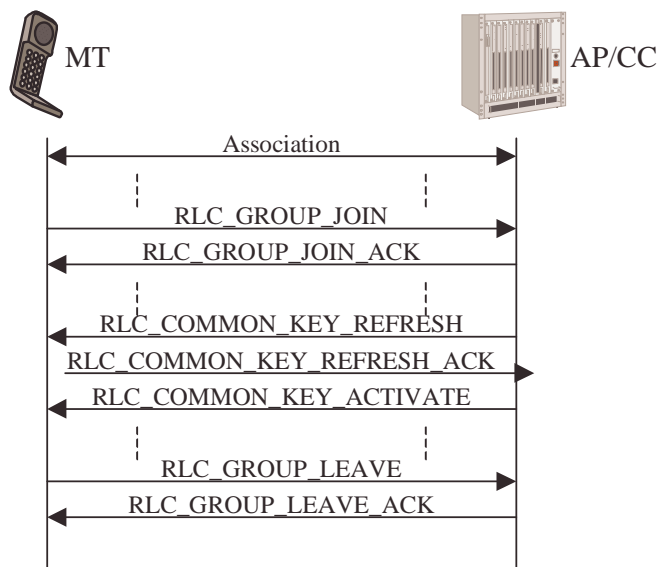

Figure A.8: A Multicast example

To join a broadcast or multicast group, the MT must first be associated with an AP/CC. There are two ways of implementing multicast:

- Using multicast MAC ID and transmitting the information once to the multicast group over the air;
- Using n times unicast, i.e. transmitting the information individually to each member of the group.

The figure above describes a scenario where the MT joins a multicast group. The MT begins with sending a join-message, to indicate what group(s) it would like to join. In this message it also specifies what encryption algorithms it supports or would like to use. The AP/CC response consists of an acknowledgment, which includes the encryption algorithm and encryption key to be used for the group(s). The AP/CC is responsible for handling the key refresh. When a MT wishes to leave a group it sends a group-leave request to the AP/CC, which the AP/CC must acknowledge.

For the broadcast scenario, similar join and leave procedures apply for the MT, as in the multicast case. Instead of sending an RLC_GROUP_JOIN request the MT sends an RLC_CL_BROADCAST_JOIN request.

Direct Link Scenario

In a direct link connection, two mobile terminals set up a direct communication channel between themselves. The data will be sent directly between the terminal, while the AP/CC still handles the control functions (see figure below). Note that when direct link is not used between two parties, all traffic must go via the AP/CC. Therefore, the direct link is a feature that helps to off-load the AP/CC, so not all traffic have to be routed through it.

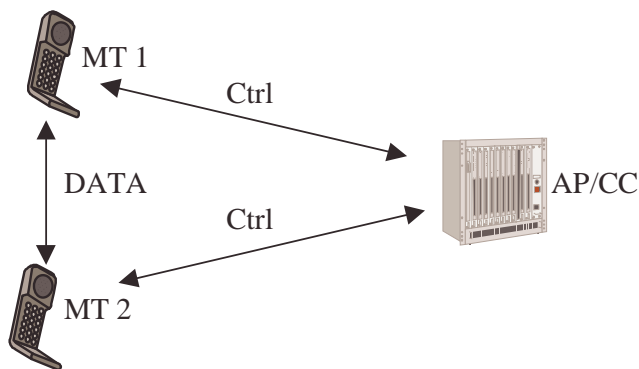

Figure A.9: The data and control flow in a direct link scenario

The figure above describes a small scenario where the AP/CC initiates a Direct Link Setup. Both terminals must be associated with the AP/CC before this can be done. The AP/CC initiates by sending the RLC_DM_SETUP message, which include information about the peer’s MAC id, common attributes etc. The AP/CC is responsible for distributing a common encryption key to the terminals and also for handling (when needed) the key refresh. To synchronize the two terminals, the AP/CC sends the RLC_DM_CONNECT_COMPLETE message.

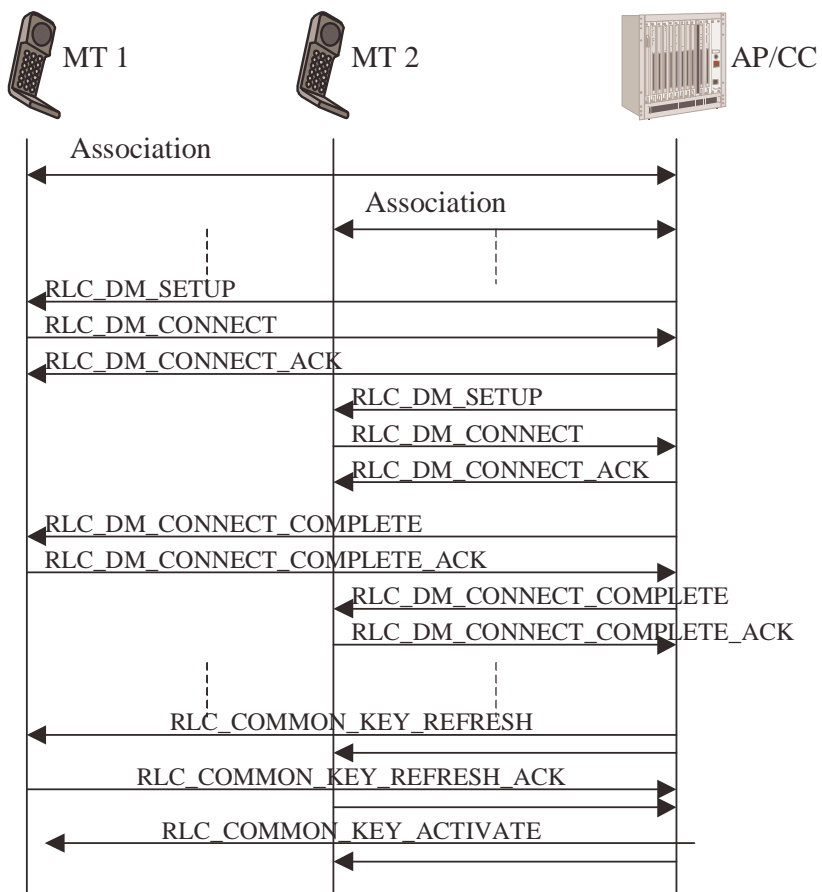

Figure A.10: AP/CC Initiated DiL setup with key refresh

A.2.2.2 Authentication

When encryption has been activated the mechanism for mutual authentication can start. Authentication with a pre-shared key is mandatory to implement and RSA based signatures are optional to implement. There are six different key identifiers and one of them is mandatory to be implemented but since all of them are optional it is a choice to choose one of them. The MT fetches the authentication key of the AP based on identities that are sent over the broadcast channels.

The MT sends a RLC_AUTHENTICATION including the type of the AKI. Upon receiving this message the AP sends a challenge to the MT. The MT calculates the response and creates a challenge to the AP. The MT sends a RLC_AUTHENTICATION_AP to the AP including the response and the challenge. The AP checks the response and if it equals the expected response the AP sends a RLC_AUTHENTICATION_ACK including the response based on the challenge sent by the MT. The MT checks the response if it is a valid one i.e. if the AP is authentic.

Since the Diffie-Hellman exchange is vulnerable to a man-in-the-middle attack this mutual authentication mechanism prevents this attack. Furthermore the proposed and selected encryption and authentication alternative is checked to prevent an attack aiming for a lower security level than requested.

The challenge response protocol is based on a good random number generator but there is no random generator specified in the standards so it is implementation specific.

Pre-shared key

The keys have to be distributed to the MTs and the APs in a secure manner. It is suggested in the standard to use this key management to business and residential environment for scalability reasons.

The responses are calculated as:

Response=HMAC-MD5(Preshared Key, AuthenticationString)

AuthenticationString = challenge [| mt_dh | ap_dh |] auth_encryption_list | auth_encr_selected

The AuthenticationString shall include the received challenge, the proposed encryption and authentication algorithms proposed by the MT and the selected encryption and authentication algorithms selected by the AP. If encryption is chosen, i.e. Encryption Startup proceeded the Authentication, then the received Diffie-Hellman public value and the sent Diffie-Hellman public value shall also be included in the AuthenticationString. The challenge is 128 bit long and the Diffie-Hellman public value is 768 bit long. The length of the pre-shared keys shall be at least 128 bit long.

RSA-based

It is suggested in the standard that a public-key certificate signed by a trusted party is an efficient way to implement this system. A PKI, Public Key Infrastructure, is needed to issue, verify and revoke public-key certificates. The signature and the verification shall be calculated by using PKCS#1 and the MD5 hash algorithm. The response is calculated as:

Response=RSASSA_PKCS_V1_5_SIGN(Private Key, AuthenticationString)

The AuthenticationString is specified in the same way as for the pre-shared key case. There are three public key lengths specified: 512, 768 and 1024 bits.

A.3 IETF

A.3.1 Co-Existence of RADIUS and Diameter

While Diameter does not share a common protocol data unit (PDU) with RADIUS [15], considerable effort has been expended in enabling backward compatibility with RADIUS, so that the two protocols may be deployed in the same network. Initially, it is expected that Diameter will be deployed within new network devices, as well as within gateways enabling communication between legacy RADIUS devices and servers. This capability, described in [223], enables Diameter support to be added to legacy networks, by addition of a gateway or proxy speaking both RADIUS [15] and Diameter [244].

RADIUS is currently widely used protocol in WLAN environments. At the same time RADIUS is missing several features, such as server initiated messages and may not operate with the highest possible security

turned on. Diameter is a better protocol, but it is not very widely deployed yet. Therefore, gradual migration from RADIUS to Diameter seems to be one potential way to go further.

It seems reasonable to start from an initial model of the AAA network where most or all of the access points implement only RADIUS, and a core which uses Diameter but is capable of talking to the RADIUS-only capable access points. This would mean that leaf AAA proxies should support both RADIUS and Diameter. As Diameter-capable access points are inserted to the network, they can be taken into use immediately. An advantage of placing the RADIUS/Diameter-capable nodes on the leafs of the network is that it becomes easier to take advantage of the features found in Diameter. For instance, even accounting may be more reliable if only the first hop is run in RADIUS but the traversal of the access provider, roaming consortium, and home operator proxies is done via DIAMETER.

The actual translation gateway must be able to run both RADIUS and Diameter protocols. The [224] extension defines a framework for the protocol conversion, where the RADIUS attribute space is included into Diameter, which eliminates the need to perform many attribute translations. However, some explicit translations between RADIUS and Diameter attributes must be made, like translating vendor specific and accounting information.

Some Diameter related messages cannot be translated during the communication with RADIUS client, such as messages initiated by Diameter server. Interoperability between RADIUS and DIAMETER in the presence of some of the non-standard RADIUS extensions has not been specified.

The gateway needs to add RADIUS application layer security mechanisms towards RADIUS, and IPsec or TLS towards Diameter. Given the use of the hop-by-hop security mechanisms, this translation can be performed without the knowledge of the original sender of the message. RADIUS requires pre-shared keys, while Diameter can take advantage of either IKE or TLS.

In addition, the translation gateway must secure attribute data towards the home server using Diameter CMS techniques (when the RFC is published). That is, end-to-end security mechanisms can be employed between the translation proxy and the home server, but not between the RADIUS-only access point and the translation proxy.

Diameter – RADIUS compatibility mode should support both protocols along with the necessary translation mechanisms in order to enable the use of RADIUS-only access points. Such translation should occur as near the leaves of the network as possible. As not all functions can be translated in full, some loss of functionality occurs for those devices, which use RADIUS.

It is possible to use IPSec in those cases where RADIUS is used, as currently required in RFC 2869bis. This may help to eliminate some of the vulnerabilities of RADIUS. In addition, 3GPP may adopt the use of RFC 2869bis and corresponding Diameter counterpart as the standard for running EAP over AAA protocols.

A.4 Bluetooth

Annex B (informative): Trust Model

B.1 Trust model entities

Although any real implementation of a trusted access solution will depend on the exact system architecture, for the high-level concepts presented in this contribution we restrict attention to the three key players: the user/customer, the cellular operator, and the WLAN access provider.

Figure B.1 shows a simplified system model showing only the three roles and their trust relationships.

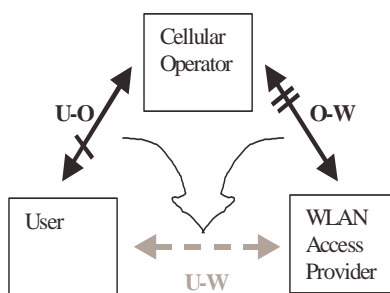

Figure B.1: Trust model

The cellular operator offers GSM/GPRS/UMTS services. Architecture-wise, the "cellular operator" box represents the complete cellular network (including radio access network, core network, service network), and also extends to partners in a roaming consortium.

The WLAN access provider offers public Wireless LAN access as a service. The "WLAN Access Provider" box in the figure groups the WLAN access network and its possible supporting nodes. The WLAN access provider may be "part of" (owned by) the cellular operator or a cellular roaming partner, or it could be a WLAN-only access provider or Wireless ISP.

The user in this model is assumed to be a subscriber/customer of the cellular operator who wishes to use both the traditional cellular services and the complementary (but not complimentary) WLAN access, when available. As such, the user is assumed to operate equipment capable of both GPRS/UMTS and WLAN access. This could be some combination of a phone (handset or PC-card) and a laptop / PDA, or possibly a combined WLAN/GPRS terminal. The collection of a user's devices acting on behalf of the user will often be called a client.

Legally, the user-operator trust relation, labelled "U-O" in figure B.1, is based on the service agreement between these two parties. From a technological perspective, this trust is embodied in a shared secret stored securely both on the user's (U)SIM and at the operator's Authentication Centre, and allows for an authenticated secure connection between the user's terminal and the cellular network.

If the cellular operator and the WLAN access provider are part of the same legal entity their trust relation is self-evident, and results in an intra-domain security solution. In the more general case, the operator-WLAN trust, labelled O-W in figure B.1, is based on roaming agreements or other partnerships (such as a Single Sign-On federation). Physically, this trust can translate to a security solution for roaming, AAA, trusted or semi-trusted servers in the context of WAP, or SMS-gateway access.

B.2 Trust relations

To design or evaluate a security solution, the trust relations between the participants must be identified. In a public WLAN access scenario, we have one or more operators and (possibly independent) access providers, and several subscribers.

The subscribers cannot trust each other. Someone else accessing the network from the same WLAN access network as the user, may be trying to perform DoS attacks targeted at the user, or eavesdrop on his traffic, steal his credentials to gain access at a later time, etc.

An operator cannot trust any mobile terminal that tries to connect to the network. Before authentication, the mobile station could belong to anyone, with or without a subscription. Even after a mobile station has been authenticated, the device may act maliciously. The user himself may be performing fiendish activities, or someone else may have hijacked his session.

The operators and/or access providers may choose to trust each other. Such trust relations normally rely on (legally binding) roaming agreements. If such an agreement is in place, a user may use another operator's access network, and will be authenticated by the "home operator". Depending on which solution is chosen, the user may have to put trust in other, visited operators, as well as in his home operator.

The cellular operators may provide the WLAN access in the future. In addition, there also will be important WLAN-only operators on the market. The level of trust of communication between the WLAN and the 3GPP system may be considered to have three levels -

- 1) The WLAN may be completely untrusted by the UE and the 3GPP system.
- 2) The WLAN contains elements that may be trusted by the UE and the 3GPP system. For example, the WLAN may include trusted servers that look after aspects of security and authentication interworking with the 3GPP systems (e.g. 802.1x, 802.11i). However, other elements of the network may be untrusted.
- 3) All of the elements of the WLAN may be fully trusted by the UE and the 3GPP system.

	LOW TRUST	HIGH TRUST
Access to services provided by the WLAN Access Provider	<ul style="list-style-type: none"> • Charging based on usage or authorisation level.maybe risky for the Cellular Operator, the accounting information may be not reliable. • Cellular Operator cannot grant user data protection. 	<ul style="list-style-type: none"> • Cellular Operator controls sessions, charging, authorisation, etc., based on information received from the WLAN Access Provider Network, and actions performed at said network. • The WLAN Access Provider is trusted to grant adequate protection of user data.
Access to services provided by the Cellular Operator	<ul style="list-style-type: none"> • Charging, authorisation enforcement, control of sessions, etc. must be performed at the Cellular Operator Network, counting on user data received via tunnels. • The tunnelling mechanism must be able to provide data origin authentication and integrity protection at least. • The tunnelling mechanism may have as end point either the HPLMN or the VPLMN, depending on some aspects e.g. the need to access services in the VPLMN 	<ul style="list-style-type: none"> • Charging, authorisation enforcement, control of sessions, etc. can be performed with participation of both networks. • It may be unnecessary that the tunnelling mechanism implements any protection mechanism, if there is protection of user data in the WLAN AP and there is some security mechanism between the WLAN AP and the Cellular Operator.

Annex C (informative): Analysis of Threats

C.1 Security for Public WLAN Access

These questions related to security in the 3GPP-WLAN architecture must be addressed:

- What needs to be protected? I.e., what are the assets, and to whom are they valuable?
- What trust relations can be assumed? I.e., who can trust whom, and to what degree? The Trust Model is described in Annex B.
- What are possible attacks against the assets, how can they be performed, and what is done to detect/prevent them?

In section 3 the relevant assets and threats to those assets are identified. section 4 contains examples of possible attacks. Countermeasures are not discussed in this contribution but the threats and specific attacks should be taken into consideration when defining security mechanisms for 3GPP-WLAN interworking.

C.2 Assets and Threats

This section describes different types of assets that are valuable to the parties involved. Threats to these assets are also identified.

C.2.1 3GPP Operator's Assets

C.2.1.1 Access to WLAN Services

The WLAN Services is what the 3GPP Network Operator is offering to its WLAN customers. The 3GPP Network Operator expects some benefit in return for providing this asset.

The following threats are relevant for this asset:

- An attacker bypasses the access control and authorisation mechanisms in order to get the WLAN services for free.
- An attacker impersonates a legitimate WLAN user. This way the attacker has free access to WLAN services and the victim gets charged for the attacker's usage of the services.
- The attacker is a legitimate WLAN user in the sense that he has a customer relationship with the operator (i.e. a WLAN user account), but he bypasses the authorisation mechanism to get services he has not paid for.
- The attacker interferes with the charging mechanism for the WLAN services, rendering a legitimate user's bills incorrect.
- The attacker is a legitimate WLAN user and he gets to interfere with the charging mechanism, e.g. to reduce the own bill.
- The attacker is a legitimate prepaid user that avoids disconnection when the prepaid account expires.
- The attacker prevents WLAN users from accessing to WLAN services (DoS).
- The attacker prevents WLAN users from accessing to the operator's WLAN services, and sets up rogue "services" (e.g. propaganda) instead.

C.2.1.2 Non-WLAN Assets

Other 3GPP operator assets may not be offered over WLAN access networks. Such assets are e.g. access to GSM/UMTS CS services, access to GPRS services, etc. There is a threat that an attacker takes advantage of the WLAN access to perform attacks (e.g. impersonation, DoS, MitM, etc.) against these assets whenever the WLAN access is not properly secured and isolated.

C.2.2 WLAN User's Assets

Since the user's subscription can be considered as an asset for the 3GPP Network Operator, the assets of the user can be considered, to some extent, as 3GPP Operator's assets too. That is, if the user perceives that the utilisation of WLAN services poses a threat to his/her assets, it is likely that the user will avoid using those services, or that the price the user is willing to pay for the services will diminish. Moreover, users might claim liability of the 3GPP Network Operator for the damage caused to their assets.

C.2.2.1 Access to WLAN Services

From the WLAN user's standpoint, this is the asset the user expects to obtain. The user is willing to pay a price to get this asset.

The following threats should be considered:

- The WLAN user gets impersonated by an attacker, which obtains access to WLAN services at the user's expense. Moreover, the attacker can utilise the WLAN services of the victim to perform deceitful activities.
- An attacker gets to make the user charged for services that the victim has not requested.
- The WLAN user cannot get WLAN services due to a DoS attack against the network, or to a targeted DoS attack against that specific user.
- The WLAN user cannot access to the operator's WLAN services, and gets rogue "services" (e.g. propaganda) set up by an attacker instead.

Note that there is some overlapping between these threats and those relevant for this asset from the 3GPP Network Operator's standpoint. For instance, a DoS attack is a problem for the user in the sense that he/she cannot get the WLAN services. It is also a problem for the Operator because it cannot charge the users for the services while they are unavailable (unless they are charged as a flat rate) and the Operator's image gets damaged. Similar arguments can be used for the rest of the overlaps.

C.2.2.2 User Data and Privacy

The user expects that the data he sends/receives while accessing to WLAN services, and personal information (such as identity, which services he/she uses or where he/she is located at a given time) is kept away from unauthorised parties.

The following threats are relevant:

- An attacker obtains the information that the user sends/receives while accessing to WLAN services. This includes user credentials transferred during the authentication phase, as well as any other data (e.g. documents) exchanged once the user has gained access to the WLAN services. The attacker might know or not who the user is.
- An attacker manipulates or substitutes the information that the user sends/receives while accessing to WLAN services. The attacker might know or not who the user is.
- An attacker analyses the information sent/received by users (even if it is mostly concealed) in order to derive some personal information about the users (such as which services they are using or where they are located at a given time).
- An attacker obtains information about the user (permanent identity etc.) and traces where and when the user has been accessing WLAN services.

C.2.3 WLAN Access Network Provider's Assets

In principle, the WLAN Access Network is outside the scope of 3GPP-WLAN interworking standardisation. Nevertheless, it is important to consider the "Access to WLAN Services" asset of the WLAN Access Network provider, since it can be regarded as a part of the "Access to WLAN Services" asset of the 3GPP Operator. In fact, many threats against the 3GPP Operator's assets can be realised by attacking the WLAN AN. Therefore, it is important that 3GPP-WLAN interworking sets security requirements on the WLAN AN and/or chooses a security solution that is robust to different levels of WLAN AN security.

The same threats as for the "Access to WLAN Services" asset of the 3GPP Operator are valid here.

C.3 Attacks

This section is an attempt to give a concrete form to the threats of the previous section, and to identify several attacks that are applicable in a typical WLAN-3GPP interworking scenario. A single attack can be used to realise one or possibly several of the threats described in the Sec. 3, depending on the intent of the attacker. An attacker setting up a rogue AP may e.g. attempt to get free access, modify a legitimate user's traffic or do a Denial of Service attack. Most of the attacks are performed by an attacker in the WLAN AN but may have implications on the 3GPP operator's assets. Attacks can also be performed remotely over the Internet. For certain types of attacks, the perpetrator does not need to "be a part" of the network. Examples are some types of layer 2 attacks and certain DoS attacks, e.g. setting up a radio jammer in a hotspot. Other attacks require that the attacker has access to the WLAN AN or the Internet. It should be noted that an easy way of getting access to the WLAN AN is to simply become a legitimate subscriber.

The attacks are classified according to where the attack is performed/launched:

- victim's WLAN UE;
- attacker's WLAN UE and/or AP;
- WLAN Access Network infrastructure;
- other device on the Internet.

The attacks mentioned are by no means the only ones possible. Moreover, the actual possibility to carry out an attack may depend on the WLAN technology and the level of WLAN specific protection used.

Even though some attacks can be easily prevented no effort is made in this section to describe countermeasures.

C.3.1 Attacks at the Victim's WLAN UE

Open platform terminals may be infected by viruses, Trojan horses or other malicious software. The software operates without the knowledge of the user on his terminal, and can be used for different types of attacks:

- If the user has credentials stored on a smart card connected to his terminal, a Trojan residing in the terminal can make fake requests to the smart card and send challenge-response results to another MS. For example, the owner of the latter MS could then get access with the stolen credentials.
Note that this attack is performed inside the terminal, and it is independent of the external link between the terminal and the smart card reader, which can be secured or assumed to be physically secure.
- Trojans may perform all the usual activities: monitor the user's keyboard or sensitive data, and forward the information to another machine.
- Malicious software can be used to perform Distributed DoS (DDoS) attacks. That is, several instantiations of the software (residing on different hosts) synchronise and start a DoS attack simultaneously against a target.
- Malicious software could be trying to connect to different WLANs, just to annoy the user.

Alternatively, the (U)SIM in the cellular phone can be used remotely from the WLAN client through a serial, infrared, or Bluetooth connection; in order to use the phone as a smart card reader. As the terminal must access the (U)SIM in the phone, the link in between must be secure. Both cable and IR can be assumed physically secure, and Bluetooth will depend highly on the current Bluetooth security mechanism.

C.3.2 Attacks from an Attacker's WLAN UE and/or AP

Several types of attacks are possible if the attacker has access to a laptop with WLAN interfaces and/or an Access Point. Denial of Service (DoS) attacks are easy to launch, e.g. by setting up a radio jammer at the hot spot. For some WLAN technologies, the layer 2 control signalling is not integrity protected opening up for DoS attacks by e.g. disassociating legitimate users.

Unless protected, an attacker can easily eavesdrop on the traffic between a user and an AP. The only equipment needed to do this is a laptop with a WLAN interface.

In a rogue AP / rogue network attack, the attacker e.g. employs an AP (masqueraded as a legitimate AP in a given hotspot) connected to a WLAN UE. Based on signal strength, an unsuspecting WLAN UE may connect to the rogue AP. This type of attack can be used to realise several different threats. The attacker could possibly modify the user's traffic or divert the traffic to a network other than the WLAN AN the user intended to use. The attacker could e.g. also fake a network or a commercial site to get access to e.g. credit card information. The attacker can also act as a Min in the Middle during the authentication procedure and cause the MAC/IP address-pair of the attacking WLAN UE to be bound to the credentials of the legitimate user. As a consequence, the attacker gains access to anything the legitimate user would, while the legitimate user is denied access.

An important class of IP-network attacks relevant in connection with rogue AP / networks are "service spoofing" attacks, where the attacker impersonates one or several services/servers in the network, e.g., a DNS server or a DHCP server. These attacks could be performed e.g. by setting up a rouge AP. Another set of attacks uses fake configuration/control messages (such as ARP or ICMP messages) to redirect a user's traffic. ARP spoofing could also be used to redirect the AP's traffic, e.g. AAA messages generated by the AP. Note that the above include only the best-known and most serious attacks. Given the rich (and always expanding) set of protocols run over IP, all possible attacks could not be accounted for.

Another way to interfere or possibly gain access for an attacker is to simply eavesdrop on the traffic around an AP. Depending on WLAN technology and the level of protection, the MAC and IP addresses may be sent in the clear (they are not encrypted) and the attacker can record these. When the attacker knows the MAC/IP address-pair of a user currently connected, he can set his own addresses to the same values.

C.3.3 Attacks at the WLAN AN Infrastructure

Attacks can be performed at the WLAN AN infrastructure, e.g. Access Points (AP), the LAN connecting the APs, Ethernet switches etc. To perform any type of attacks "inside" the WLAN AN, the attacker needs access to the network in some way. For ordinary wired networks, an attacker needs to somehow hook up to the wires to get access. The WLAN AN is partially a wired network, and an attacker may hook up to that part of the network. In public spaces the APs and corresponding wired connections may be physically accessible by attackers. Simply connecting a laptop to the wired LAN "behind" the APs may give the attacker free access to WLAN services as well as access to other user's data and signalling traffic.

Depending on where charging data is collected, an attacker with access to the wired LAN of the WLAN AN can also interfere with the charging functions. If the volume based charging model is applied, an attacker could e.g. inject packets with any chosen source or destination MAC and IP addresses, just to increase a user's bill.

C.3.4 Attacks Performed by Other Devices on the Internet

Several attacks can be performed from devices connected to the Internet.

If the volume based charging model is applied, an attacker could flood a user with garbage packets, just to increase the user's bill. This is e.g. effective if the attacker resides somewhere on the Internet with a flat rate charging model, or if the attacker has infected other users' machines with "bot"-software. (Bot is short for robot, and refers to software that "lives on its own"). The bot could for instance listen for connections on a certain port, and when receiving a command from the attacker on that port, it starts flooding a given IP address with packets. Various distributed denial of service (DDoS) tools using such bots are known and available in the hacker world.

Annex D (informative): Management of sequence numbers

The example sequence number management schemes in [21] Informative Annex C can be used to ensure that the authentication failure rate due to synchronization failures is kept sufficiently low when the same sequence number mechanism and data is used for authentication in the PS/CS domains, in IMS and WLAN. This can be done by enhancing the method for the allocation of index values in the AuC so that authentication vectors distributed to different service domains shall always have different index values (i.e. separate ranges of index values are reserved for PS, CS, IMS operation and WLAN access). The AuC is required to obtain information about which type of service node has requested the authentication vectors. Reallocation of array elements to the IMS domain can be done in the AuC with no changes required to already deployed USIMs.

As the possibility for out of order use of authentication vectors within the WLAN service domain may be quite low, the number of existing array elements that need to be reallocated to the WLAN domain could be quite small. This means that the ability to support out of order authentication vectors within the PS, CS and IMS domains would not be significantly affected.

Sequence number management is operator specific and for some proprietary schemes over the air updating of the UICC may be needed.

Annex E (informative): Change history

Change history							
Date	TSG #	TSG Doc.	CR	Rev	Subject/Comment	Old	New
2002-07					First draft created by the editor		0.1.0
2002-11					Updated after SA3#25	0.1.0	0.2.0
2002-11					Updated after SA3#26	0.2.0	0.3.0
2003-03					Updates after SA3#27	0.3.0	0.4.0
2003-06					Updates after SA3#28	0.4.0	0.5.0
2003-09					Updates after SA3#29	0.5.0	0.6.0
2003-11					Updates after SA3#30	0.6.0	0.7.0

18-21 November 2003

Munich, Germany

Agenda Item: 6.11 WLAN inter-working
Source: Ericsson
Title: Split WLAN-UE: SIM Access Profile protocol in Bluetooth forum
Document for: Discussion and decision

1. Introduction

Ericsson presented a document in S3-030251 to SA3 #28, which presented a proposal for split WLAN-UE where SIM access could be provided from a 3GPP UE to an external device as Laptop, by the use of the SIM Access Profile protocol via a Bluetooth link. In this paper (S3-030251) a number of proposals on changes to the SIM Access Profile protocol were presented, in order to better suite the usage model of a split WLAN UE in simultaneous WLAN and GSM/UMTS access.

Ericsson proposes that SA3 discuss each proposal presented in this paper and takes a decision in order to progress the work in Bluetooth forum. Ericsson has separate discussions paper on [Split WLAN UE: Termination of EAP-AKA/SIM protocol] and [Split WLAN-UE: Integrity protection on local interface] for this SA3 meeting.

2. Discussion

2.1 Information required by an external WLAN client from a UICC or SIM card inserted into a 3G/2G UE

A WLAN client residing in an external device (e.g. Laptop) would require the following information from a UICC or SIM card inserted into a 3G/2G UE:

- The knowledge of whether a GSM SIM or UICC card is inserted.
- Read IMSI from a GSM or USIM application;
- Send authentication challenge requests to the GSM and USIM application.
- Receive authentication challenge responses from the GSM and USIM application.

To Ericsson knowledge, these requirements are possible to fulfill already today with the SIM Access Profile, and would not require any further changes.

2.2 New requirements on SIM Access Profile

The following issues are discussed in separate papers from Ericsson in this meeting:

- Termination of EAP-AKA and EAP-SIM in split WLAN UE;
- Need for integrity protection on local interface with a Bluetooth link between the UE and the Laptop;

and agreements from these discussions shall be communicated to the Bluetooth forum, if the SIM Access Profile protocol is impacted.

In addition, it is proposed that the following new requirements on the SIM Access Profile shall be communicated as well:

- Allow a 2G/3G UE to access a 2G or 3G network and simultaneously allow a SIM Access Profile connection to an external TE via a BLUETOOTH link, in order to provide SIM/UICC access to a WLAN client running in a TE (e.g. Laptop).
- The 3G/2G UE shall be required to be switched on and a SIM/UICC card shall be powered on, in order to allow and accept a request from a TE to establish a SIM Access Profile connection.
- It shall NOT be possible from a TE (e.g. laptop) to reset, power on or off a SIM/UICC card inserted into a 3G/2G UE, as the SIM/UICC is already in use for GSM or UMTS access in the 2G/3G UE. Therefore it is proposed that the following features in the SIM ACCESS PROFILE shall NOT be supported in the new version of the specification:
 1. Reset SIM or USIM in the 2G/3G UE;
 2. Power on the SIM or USIM in the 2G/3G UE;
 3. Power off the SIM or USIM in the 2G/3G UE.
- PIN or password in Bluetooth:

In BLUETOOTH a PIN or password of 16 characters is required today. This is not so user friendly. We encourage the usage of an improved pairing proposed by the BLUETOOTH SIG Security Expert Group to be used by the 'SIM Access Profile'. An improved pairing would allow a shorter PIN or password without providing less security.

3. Proposals

Ericsson proposes to send an LS with the requirements in this paper to the Bluetooth Architecture Review Board (BARB) and the CAR groups, asking them to develop a new version of the SIM Access Profile for a split WLAN UE in work item WLAN Inter-working in 3GPP.

4. References

- [1] SIM Access Profile, Interoperability Specification, version 0.95VD - d. Document no. CAR 020 SPEC/0.95cB.
- [2] 3GPP TS 33.234 V0.4.0 "Wireless Local Area Network (WLAN) Interworking Security".
- [3] S3-030251 SIM access via 'SIM Access Profile' and Bluetooth link, from Ericsson in SA3 #28.
- [4] S3-030xxx Split WLAN UE: Termination of EAP-AKA/SIM protocol, from Ericsson.
- [5] S3-030xxx Split WLAN-UE: Integrity protection on local interface, from Ericsson.

Agenda Item: 6.10 (WLAN)
Source: Siemens
Title: Pseudo-CR to TS 33.234 on Requirements on UE split
Document for: Discussion and decision

Abstract

TS 33.234 v070 (S3-030xxx) contains an editor's note regarding the termination point of EAP-AKA and EAP-SIM respectively in a WLAN_UE functional split scenario. This contribution proposes to include a related requirement into TS 33.234 (WLAN security). A threat scenario is given to motivate the proposal.

1. Security aspects of termination points of EAP-AKA and EAP-SIM

The following familiar figure depicts a WLAN_UE functional split scenario:



The mobile phone (the “card holding device”) on the left holds the UICC or SIM (the “card”) and the laptop holds the functions for WLAN access (the “WLAN access device”). The network is not aware of the UE functional split. Typically the card holding device also has a network interface (although not necessarily WLAN interface) , e.g. a GSM or UTRAN interface.

The specifications of EAP-AKA [eapaka] and EAP-SIM [eapsim] only know an EAP “peer” whose functions have to be performed by the UE, i.e. card holding device, WLAN access device and card combined. It is discussed in this contribution how the functionality of the EAP peer should be distributed over the physical devices which make up the UE.

Alternative 1: all functions of an EAP peer are executed on the WLAN access device, with the exception of the functions executed by the SIM or USIM, which are defined in GSM 03.20 and 3G TS 33.102 (i.e. basically the cryptographic algorithms A3/A8 and f1-f5 respectively). The card holding device only transfers data between the WLAN access device and the card transparently. This implies in particular that the WLAN access device receives the GSM or UMTS session keys Kc or CK, IK.

Evaluation: Alternative 1 seems the straightforward approach. However, it has a serious security drawback, which is already mentioned in draft TR “ on (U)SIM Security Reuse by Peripheral Devices on Local Interfaces” (S3-030666). Section 5.2.1 of S3-030666 states:

“Now when (U)SIM is being used directly or re-used to authenticate open mobile platforms like Laptop PCs and PDAs, the protection of these parameters [i.e. authentication parameters and session keys] become even more

necessary as the likelihood of threats are much higher. This especially true when 3GPP is considering the SIM and USIM based authentication for WLAN terminals.”

This means: if an attacker mounts a successful attack on the WLAN access device he can get hold of the GSM or UMTS session keys. With these keys, he can perform attacks not only on the WLAN access, but also on other domains in GSM or UMTS, e.g. the CS or PS domain. The attacks, which become possible when the attacker is in possession of the session keys, are well-known. They include false base station attacks, eavesdropping and user impersonation.

This leads to the following **security requirement**:

The UE functional split shall be such that attacking the CS or PS domain by compromising the WLAN access device is at least as difficult as attacking the CS or PS domain by compromising the card holding device.

Remark: the requirement is stated in this way because it is acknowledged that there may be situations where the risk of compromise of the WLAN access device is similar to that of the card holding device. In such a situation it would make no difference whether the WLAN access device knows the GSM or UMTS session keys. In the general situation, however, it may make sense to prevent that the WLAN access device knows the GSM or UMTS session keys. The security requirement is satisfied if, in particular, the WLAN access device is not able to infer the GSM or UMTS session keys from the information it receives.

Alternative 2: all functions of an EAP peer are executed on the card holding device, with the exception of the functions executed by the SIM or USIM as specified in GSM 03.20 and 3G TS 33.102. The WLAN access device only transfers data between the card holding device and the network transparently.

Evaluation: in alternative 2, the WLAN access device cannot get hold of the GSM or UMTS session keys, and the above security requirement is fulfilled. But there may be performance disadvantages. Often, the card holding device is much less powerful than the WLAN access device, and therefore it would be better from a performance point of view that as many functions of an EAP peer as still compatible with the above security requirement are executed on the WLAN access device.

Alternative 3: the card holding device computes the master key for EAP-SIM and EAP-AKA from the GSM and UMTS session keys, the remaining functions of an EAP peer outside the card are executed in the WLAN access device.

I.e. the card holding device computes

$MK = SHA1(Identity|IK|CK)$ for EAP-AKA, cf. [eapaka, section 4.5] and

$MK = SHA1(Identity|n*Kc|NONCE_MT|Version\ List|Selected\ Version)$ for EAP-SIM, cf. [eapsim, section 4.6].

The card holding device then forwards the *MK* to the WLAN access device.

Evaluation: the security requirement is fulfilled, and the card holding device performs only the minimum of functions required so that the WLAN access device is not able to infer the GSM or UMTS session keys from the information it receives.

Further alternatives: of course, any alternative where the function split between card holding device and the WLAN access device is in between alternatives 2 and 3, also fulfils the above security requirement. Depending on the relative capabilities of the two devices, the precise split between the two devices may or may not be of particular relevance.

Enhanced role of the card: more functions could be performed on the card. But there seems to be no obvious security advantage compared with performing the functions on the card holding device, if the latter obtains the GSM and UMTS session keys for access to GSM and UMTS anyhow.

2. Proposal

Based on the evaluation in section 1, it is proposed to make the following change to section 4.2.4.1 of TS 33.234 v070. The changes can be seen from the revision marks.

*****BEGIN OF CHANGE*****

4.2.4 WLAN-UE Functional Split

4.2.4.1 General

In the case when the WLAN-UE, equipped with a UICC (or SIM card), for accessing the WLAN interworking service, is functionally split over several physical devices, one device holding the card, and one device providing the WLAN access, that communicate over local interfaces e.g. Bluetooth, IR or serial cable interface, then it shall be:

- Possible to re-use existing UICC and GSM SIM cards; and
- The UE functional split shall be such that attacking the CS or PS domain of GSM or UMTS by compromising the device providing the WLAN access is at least as difficult as attacking the CS or PS domain by compromising the card holding device.

Note: The requirement is fulfilled if the master keys for EAP-AKA and EAP-SIM, as specified in [4] and [5], are computed either on the card or in the card holding device.

[Editor's note: The termination point of EAP is for further study e.g. if EAP-AKA and EAP-SIM shall terminate in the TE e.g. laptop computer. The decision on the termination point shall take into account the requirements in this subsection.].

*****END OF CHANGE*****

References

[eapaka] J. Arkko, H. Haverinen, „EAP AKA Authentication“, Internet Draft, draft-arkko-pppext-eap-aka-11, October 2003. <http://www.ietf.org/internet-drafts/draft-arkko-pppext-eap-aka-11.txt>

[eapsim] H. Haverinen, J. Salowey „EAP SIM Authentication“, Internet Draft, draft-haverinen-pppext-eap-sim-12, October 2003. <http://www.ietf.org/internet-drafts/draft-haverinen-pppext-eap-sim-12.txt>

18-21 November 2003

Munich, Germany

Agenda Item: 6.11 WLAN inter-working
Source: Ericsson
Title: Split WLAN UE: Termination of EAP-AKA/SIM protocol
Document for: Discussion and decision

1. Introduction

The user can get WLAN access with either a SIM card or UICC card. The 3GPP network will initiate protocols as EAP-AKA and EAP-SIM to authenticate the WLAN UE with a SIM or UICC card will be used for mutual authentication by the 3GPP network and the WLAN UE.

When the WLAN UE is split between two physical devices (i.e. Laptop and 3GPP UE), SA3 needs to decide where the EAP-AKA and EAP-SIM procedures shall be terminated. This paper discusses whether EAP-AKA and EAP-SIM protocols should be terminated in the Laptop or in the 3GPP UE.

The term “local interface” refers to the interface between a Laptop and a 3GPP UE. The discussion in this paper is based on the assumption of a Bluetooth link between the Laptop and the 3GPP UE; and that “SIM Access Profile” is used to provide SIM/UICC access to an external physical device.

Note that when the term 3GPP UE is used, the intention is to terminate EAP-AKA and EAP-SIM in the terminal itself and not on the smart card.

2 Background

In SA2, different scenarios have been defined in the WI WLAN Inter-working. It is expected that scenario 2 and 3 from TS 23.234, will be in REL-6.

Scenario 2 in WLAN Inter-working

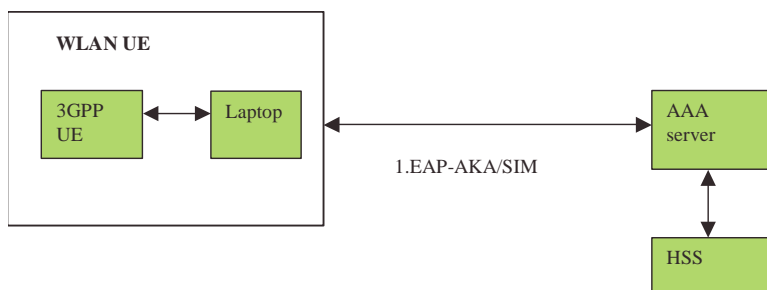

Figure 1

In scenario 2, a successful EAP-AKA and EAP-SIM between the network and WLAN UE is required, in order for the WLAN UE to get WLAN access. EAP-AKA/SIM takes only place in the Link Layer.

Scenario 3 in WLAN Inter-working

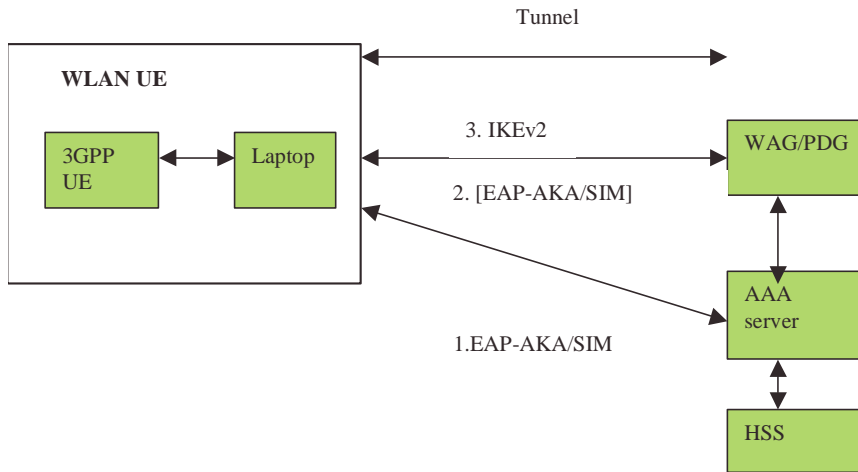

Figure 2

In scenario 3, an 3GPP operator can offer 3GPP services to the user via WLAN access. To achieve this, a tunnel between the 3GPP network and the WLAN UE needs to be established. Two different solutions are currently discussed in SA2, 1) Tunnel switching and 2) End-to-end tunnelling. These two solutions do not have impact on the discussion in this paper.

In SA3 #30, Siemens and Nokia presented contributions on how to secure the tunnel and a number of working assumptions were made like:

- Use IPsec ESP to protect the tunnels between UE and PDG required by scenario 3.
- **The security mechanisms used in context with the IP tunnel in scenario 3 are to be independent of the link layer security in scenario 2.**
- SA WG3 will concentrate their further study on IKE and IKEv2.

This discussion is still ongoing in SA3.

3. Discussion

3.1 Background on security in Bluetooth and SIM Access Profile

In the scenarios discussed in this paper, we assume a Bluetooth link between the Laptop and the 3GPP UE, which provides protection as encryption. Note that Bluetooth does not provide any integrity protection.

The “SIM Access Profile” does not provide any security.

3.2 Assumptions

This paper is based on a number of assumptions.

For scenario 2:

- EAP-AKA and EAP-SIM in the Link layer is only used for user authentication to provide WLAN access to the user.
- Security key(s) produced at EAP-AKA and EAP-SIM at the Link Layer, will not be taken into use by the WLAN-UE or the network.

For scenario 3:

- EAP-AKA and EAP-SIM in the Link layer is only used for user authentication to provide WLAN access to the user.
- Security key(s) produced at EAP-AKA and EAP-SIM at the Link Layer, will not be taken into use by the WLAN-UE or the network.
- The Tunnel established between the 3GPP network and the WLAN UE, terminates in the Laptop;
- An additional EAP-AKA and EAP-SIM procedure will take place at tunnel establishment This EAP-AKA and EAP-SIM procedure at tunnel establishment, is separate from the one taking place in the Link Layer;
- The security keys produced at EAP-AKA and EAP-SIM, will be used by the Laptop to secure the IP-sec tunnel between the Laptop and the 3GPP network. It is expected that an encryption key and integrity key are required in the Laptop and network to protect an IP-sec tunnel.

3.4 Termination of EAP-AKA/SIM in split WLAN UE

3.4.1 Termination of EAP-AKA/SIM in the Laptop

In this proposal, the EAP-AKA and EAP-SIM procedure towards the network terminates in the Laptop. The 3GPP UE is not aware of the EAP-AKA and EAP-SIM protocols. After the completion of the EAP-AKA and EAP-SIM procedures, the security keys are stored in the Laptop.

The SIM-ME interface described in TS 31.102 and 11.11 will be extended from the UE to the Laptop. The APDU's specified in these technical specifications, will be carried by the SIM Access Profile protocol specified in [1].

In scenario 2 and scenario 3, the security key(s) will always be sent from the 3GPP UE to the Laptop in an APDU (e.g. SRES and Kc; or RES, CK, IK) when EAP-SIM and EAP-AKA takes place.

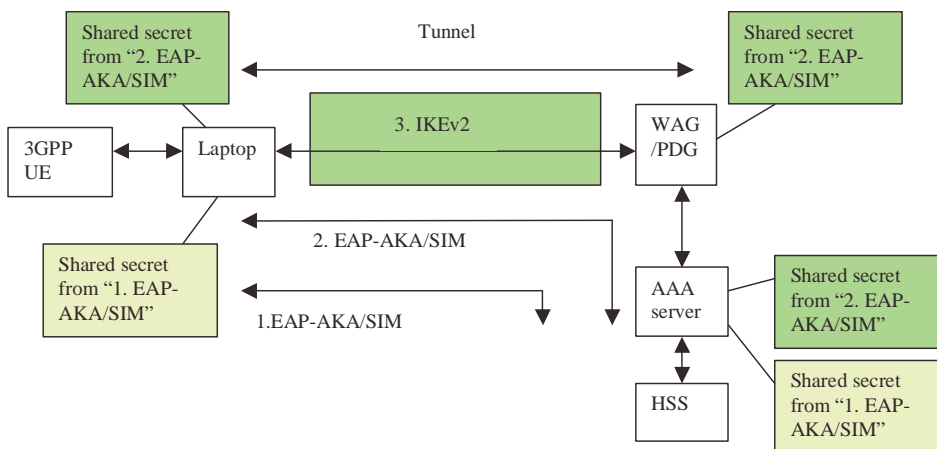

3.4.1.1 Trust model

The 3GPP network trust that the Laptop can establish a secured tunnel with the 3GPP network.

The 3GPP operator also trust that the Laptop can securely terminate EAP-AKA and EAP-SIM protocols in the Laptop, and handle these protocols with the 3GPP network.

The 3GPP UE trust that the Laptop can handle the information the 3GPP UE sends to the Laptop.

The 3GPP operator and the Laptop trust that the 3GPP UE can authenticate towards a SIM or UICC on behalf of the Laptop and provide user identity as IMSI to the Laptop.

The 3GPP operator has trust in the SIM and UICC card.

3.4.1.2 Security aspects

3.4.1.2.1 Attacks on the RAND, AUTN, RES, or the SRES

In the EAP-AKA and EAP-SIM protocols, parameters as RAND, AUTN, RES are protected by a separate MAC in the EAP-AKA and EAP-SIM protocols. If EAP-AKA and EAP-SIM terminates in the Laptop, this MAC will NOT be used on the local interface between the Laptop and UE, to protect the RAND, AUTN, RES or SRES.

Attacks on RAND and AUTN, in the Laptop or on the local interface, will cause that the authentication will fail on the USIM. The consequences will be that the user either will not get any WLAN access or the tunnel establishment between the network and Laptop would fail.

Attacks on the SRES or RES, in the Laptop or on the local interface, will cause that the authentication will fail in the network. The consequences will be that the user either will not get any WLAN access or the tunnel establishment between the network and Laptop would fail.

Introduction of integrity protection on the local interface would mean that the Laptop and UE can detect the attacks on the local interface and discard the messages, which fails the integrity check. The consequence will be that timer expiration in the network and the Laptop would take place, and trigger retransmissions of the EAP-messages. After a number of failed retransmissions the consequences will be that the user either will not get any WLAN access or the tunnel establishment would fail. So the consequence would be the same as if integrity protection was not supported.

3.4.1.2.2 Attacks on the security keys in Scenario 3

The security keys produced at EAP-AKA and EAP-SIM will be transferred from the UE to the Laptop, in a APDU carried by the SIM Access Profile. These security keys will be encrypted by Bluetooth on the local interface.

For an attacker to get hold of the security keys sent from the 3GPP UE to the Laptop, an attacker must break the Bluetooth cipher. Integrity protection protects only against man-in-the-middle attacks, which results in corrupted keys and tunnel establishment failure.

The security keys can also be attacked in the Laptop, which also results in corrupted keys. The consequences will be that the tunnel establishment will fail.

In EAP-SIM a number of challenges towards the SIM takes place, and all the Kc values from these challenges are hashed into a new Kc value in the Laptop, to be used to protect the tunnel with the 3GPP network. The most serious attack with terminating EAP-SIM in the Laptop, is that an attacker in the Laptop can take the RAND and Kc values, and display those publicly.

3.4.2.3 Impacts on SIM Access Profile protocol

EAP-AKA and EAP-SIM termination in the Laptop, would have the following impacts on the SIM Access Profile protocol in [1]:

- None.

3.4.3 Termination of EAP-AKA/SIM in the 3GPP UE

In this proposal EAP-AKA and EAP-SIM terminates in the 3GPP UE. The EAP-AKA and EAP-SIM procedures will be completely transparent to the Laptop. After the completion of EAP-AKA and EAP-SIM, the security keys are stored in the 3GPP UE. These security keys, needs to be transferred from the UE to the Laptop over the local interface.

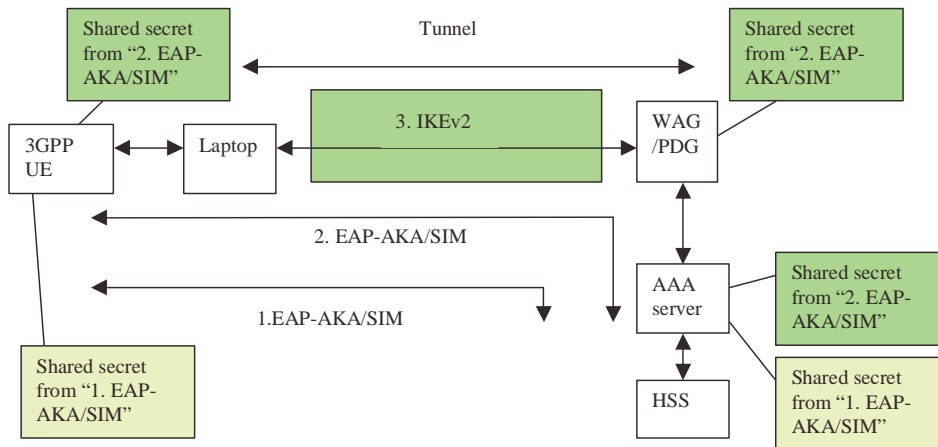

3.4.3.1 Trust model

In this proposal, the 3GPP operator has more trust in the 3GPP UE than the Laptop.

On the other hand, the 3GPP network trusts that the Laptop can establish a secured tunnel with the 3GPP network.

The 3GPP operator also trusts that the 3GPP UE can securely terminate EAP-AKA and EAP-SIM protocols in the 3GPP UE, and handle these protocols with the 3GPP network.

The 3GPP UE trusts that the Laptop can handle the information the 3GPP UE sends to the Laptop.

The 3GPP operator and the Laptop trust that the 3GPP UE can authenticate towards a SIM or UICC on behalf of the Laptop and provide user identity as IMSI to the Laptop.

The 3GPP operator has trust in the SIM and UICC card.

3.4.3.2 Security aspects

3.4.3.1.1 Attacks on RAND, AUTN, RES, SRES

In the EAP-AKA and EAP-SIM protocols, a MAC protects the RAND, AUTN, RES and SRES. As the EAP-AKA and EAP-SIM protocol terminates in the 3GPP UE, this MAC will provide protection for the RAND, AUTN, RES and SRES on the local interface as well. This is an advantage compared to the termination of EAP-AKA/SIM protocols in the Laptop, when no integrity protection is provided on the local interface.

Attacks on the RAND and AUTN in the Laptop or on the local interface, will be detected by the 3GPP UE by the MAC, which will simply discard the messages. Expiration of timers will initiate retransmissions of EAP-AKA/SIM messages.

Attacks on the SRES or RES in the Laptop or on the local interface, will be detected by the network by the MAC provided by EAP-AKA and EAP-SIM. The network will attempt to re-authenticate the WLAN UE a number of times before determining that the user authentication has failed. When user authentication is deemed as failed, the user will not get WLAN access or the tunnel establishment between the 3GPP network and the Laptop will fail.

3.4.3.1.2 Attacks on security key(s) in Scenario 3

The security keys from the SIM/USIM at EAP-AKA/SIM₂ are stored in the 3GPP UE, as EAP-AKA/SIM terminates in the 3GPP UE. These keys need to be transferred from the 3GPP UE to the Laptop, to be used to secure the tunnel between the Laptop and network. A new command needs to be defined in the SIM Access Profile protocol to carry these security keys from the 3GPP UE to the Laptop.

If a MAC was introduced to protect the security keys by the 3GPP UE, the Laptop would be able to detect an attack on the local interface. If the security keys are attacked the tunnel establishment will fail. For an attacker to get hold of the security keys on the local interface, he needs to break the Bluetooth cipher.

The Laptop manufacturer needs to ensure that the security keys will not be attacked themselves in the Laptop. Otherwise the tunnel establishment will fail. The question is how severe such an attack on the security keys on the local interface or in the Laptop is considered? Is it a big threat if the tunnel establishment fails?

In EAP-SIM a number of challenges towards the SIM takes place, and all the Kc values from these challenges are hashed into a new Kc value by the 3GPP UE. The new hashed Kc value needs to be transferred by the 3GPP UE to the Laptop, to be used to protect the tunnel with the 3GPP network. An attacker in the Laptop can get hold of the new hashed Kc value together with the RAND, and display them publicly.

3.4.3.3 Impacts on SIM Access Profile protocol

EAP-AKA and EAP-SIM termination in the 3GPP UE, would have the following impacts on the SIM Access Profile protocol in [1]:

- A new command needs to be defined to carry EAP-AKA/SIM messages between the Laptop and UE;
- A new command needs to be defined to carry security keys from the 3GPP UE to the Laptop;

3.4.3.4 Impacts on 3GPP UE

3GPP UE is required to support EAP-AKA and EAP-SIM protocols.

3.4.4 Other issues related to key management in the Laptop for both proposals

Other issue related to key management in the Laptop:

- With EAP-SIM and a GSM SIM card, only an encryption key (Kc), is available. An Integrity key needs to be derived from Kc as well. This key derivation function needs to be defined for the Laptop.

4. Conclusions

The 3GPP operator needs to have trust in the Laptop, in order for the user to get WLAN access and also that the Laptop has the capability to secure an IP-sec tunnel with the 3GPP network. If this would fail in the Laptop because of malicious software, then the user simply would not get the services from the 3GPP operator via WLAN access. This should not be seen as a major threat as the user will not get charged.

Adding integrity protection to the local interface could help the Laptop and UE to detect man-in-the-middle attacks on the local interface, but once again the consequence with these attacks will be that the user will not get WLAN access or the tunnel establishment will fail. The Bluetooth cipher protects the security keys from eavesdropping. Currently today, there exists no practical attack on the Bluetooth cipher.

EAP-AKA and EAP-SIM termination in 3GPP UE would provide some more security, as RAND, AUTN, RES and SRES are protected by a MAC, on the local interface between the Laptop and 3GPP UE

As the security key(s) from the SIM/USIM at EAP-AKA and EAP-SIM procedures needs to be transferred to the Laptop to be used to secure the IP-sec tunnel with either solution, the actual termination of the EAP-AKA and EAP-SIM protocols would not have any impact on the transfer of the security key(s) to the Laptop.

The main issue seems to be the case when EAP-SIM terminates in the Laptop and the threat exists that an attacker in the Laptop can get hold of the RAND and Kc, and distribute these publicly.

5. Proposals

SA3 needs to take a decision on whether EAP-AKA and EAP-SIM shall terminate in the Laptop or the 3GPP UE. This issue needs to be solved in order to proceed this work on split WLAN UE and finalise the requirement in the TS on split WLAN UE.

The main issue from this analyze seems to be the case when EAP-SIM protocol terminates in the Laptop and the threat exists that an attacker in the Laptop can get hold of the RAND and Kc, and distribute these publicly . SA3 needs to consider whether this is seen as a major threat. If so, then it should be considered to terminate EAP-AKA and EAP-SIM in the 3GPP UE. If this is not seen as a major threat, then Ericsson proposes to terminate EAP-AKA and EAP-SIM in the Laptop. (Note that in the use case when an external smart card reader is connected to a Laptop, EAP-AKA and EAP-SIM needs to terminate in the Laptop).

It should be mentioned that the WLAN UE may support either EAP-AKA or EAP-SIM, or both procedures, as there today exists no requirement on the WLAN UE regarding support of these protocols in TS 33.234. Also one should remember that the operator has the capability in the future to migrate from EAP-SIM to EAP-AKA, if it is felt that this is necessary.

It is proposed that TS 33.234 is updated with the decision taken in this meeting.

6. References

- [1] SIM Access Profile, Interoperability Specification, version 0.95VD - d. Document no. CAR 020 SPEC/0.95cB.
- [2] 3GPP TS 33.234 V0.4.0 “Wireless Local Area Network (WLAN) Interworking Security”.