

**3rd Generation Partnership Project;
Technical Specification Group Services and System Aspects;
Generic Authentication Architecture (GAA);
Support for Subscriber Certificates
(Release 6)**



The present document has been developed within the 3rd Generation Partnership Project (3GPP™) and may be further elaborated for the purposes of 3GPP.

The present document has not been subject to any approval process by the 3GPP Organizational Partners and shall not be implemented. This Specification is provided for future development work within 3GPP only. The Organizational Partners accept no liability for any use of this Specification. Specifications and reports for implementation of the 3GPP™ system should be obtained via the 3GPP Organizational Partners' Publications Offices.

Remove GSM logo from the cover page for pure 3rd Generation documents.

Select keywords from list provided in specs database.

Keywords

<keyword[, keyword]>

3GPP

Postal address

3GPP support office address

650 Route des Lucioles - Sophia Antipolis
Valbonne - FRANCE
Tel.: +33 4 92 94 42 00 Fax: +33 4 93 65 47 16

Internet

<http://www.3gpp.org>

Copyright Notification

No part may be reproduced except as authorized by written permission.
The copyright and the foregoing restriction extend to reproduction in all media.

© 2002, 3GPP Organizational Partners (ARIB, CWTS, ETSI, T1, TTA, TTC).
All rights reserved.

Contents

Foreword.....	4
Introduction.....	4
1 Scope.....	5
2 References.....	5
3 Definitions, symbols and abbreviations.....	6
3.1 Definitions.....	6
3.2 Symbols.....	6
3.3 Abbreviations.....	6
4 Support for Subscriber Certificates.....	7
4.1 Introduction.....	7
4.2 Requirements and principles for issuing subscriber certificates.....	7
4.2.1 Requirements on Ua interface.....	7
4.2.2 Requirements on Zn interface.....	8
4.3 Certificate issuing.....	8
Annex <A> (informative): Support for subscriber certificates based on bootstrapping.....	9
A.1 Introduction.....	9
A.2 Additional requirements and principles.....	9
A.2.1 Usage of Bootstrapping.....	9
A.2.2 Access independence.....	9
A.2.3 Roaming and service network support.....	9
A.2.4 Home operator control.....	9
A.2.5 Charging principles.....	9
A.2.6 Subscriber Certificate Profile.....	10
A.2.7 Service Discovery.....	10
A.3 Certificate issuing architecture.....	10
A.3.1 Reference model.....	10
A.3.2 Network elements.....	11
A.3.2.1 PKI Portal.....	11
A.3.2.2 Bootstrapping Server Function.....	11
A.3.2.3 UE11	
A.3.3 Reference points.....	11
A.3.3.1 Ua interface.....	11
A.3.3.1.1 General description.....	11
A.3.3.1.2 Functionality and protocols.....	11
A.3.3.1.2.1 PKCS#10 with HTTP Digest Authentication.....	12
A.3.3.1.2.2 Certificate Management Protocols (CMP).....	12
A.4 Certificate issuing procedure.....	13
A.4.1 Certificate issuing.....	13
A.4.1.1 Certificate issuing using PKCS#10 with HTTP Digest Authentication.....	13
A.4.1.2 Certificate issuing with CMP.....	14
A.4.1.2.1 Basic authenticated scheme.....	14
A.4.1.2.2 Centralized scheme initiated by the UE.....	14
A.4.2 CA Certificate delivery.....	16
A.4.2.1 CA Certificate delivery with HTTP Digest Authentication.....	16
A.4.2.2 CA Certificate delivery with CMP.....	16
A.5 Functionality in presence of pre-certified key pair.....	17
Annex <X> (informative): Change history.....	18

Foreword

This Technical Specification has been produced by the 3rd Generation Partnership Project (3GPP).

The contents of the present document are subject to continuing work within the TSG and may change following formal TSG approval. Should the TSG modify the contents of the present document, it will be re-released by the TSG with an identifying change of release date and an increase in version number as follows:

Version x.y.z

where:

- x the first digit:
 - 1 presented to TSG for information;
 - 2 presented to TSG for approval;
 - 3 or greater indicates TSG approved document under change control.
- y the second digit is incremented for all changes of substance, i.e. technical enhancements, corrections, updates, etc.
- z the third digit is incremented when editorial only changes have been incorporated in the document.

Introduction

This clause is optional. If it exists, it is always the second unnumbered clause.

1 Scope

This clause shall start on a new page.

The present document ...

2 References

The following documents contain provisions which, through reference in this text, constitute provisions of the present document.

- References are either specific (identified by date of publication, edition number, version number, etc.) or non-specific.
- For a specific reference, subsequent revisions do not apply.
- For a non-specific reference, the latest version applies. In the case of a reference to a 3GPP document (including a GSM document), a non-specific reference implicitly refers to the latest version of that document *in the same Release as the present document*.

[<seq>] <doctype> <#>[([up to and including]{yyyy[-mm]|V<a[b.c]>}[onwards]): "<Title>".

[1] 3GPP TR 41.001: "GSM Release specifications".

[2] 3GPP TR 21.912 (V3.1.0): "Example 2, using fixed text".

[3] 3GPP TS 31.102: "Characteristics of the USIM Application".

[4] 3GPP TS 33.102: "Security Architecture".

[PKCS10] "PKCS#10 v1.7: Certification Request Syntax Standard", RSA Laboratories, May 2000.

[RFC2510] Adams C., Farrell S., "Internet X.509 Public Key Infrastructure Certificate Management Protocols", RFC 2510, March 1999.

[RFC2511] Myers M., et al., "Internet X.509 Certificate Request Message Format", RFC 2511, March 1999.

[RFC2527] Chokhani S., et al, "Internet X.509 Public Key Infrastructure Certificate Policy and Certification Practices Framework", RFC 2527, March 1999.

[RFC2617] Franks J., et al, "HTTP Authentication: Basic and Digest Access Authentication", RFC 2617, June 1999.

[RFC3280] Housley R., et al, "Internet X.509 Public Key Infrastructure Certificate and Certificate Revocation List (CRL) Profile", RFC 3280, April 2002.

[RFC 3310] A. Niemi, et al, "Hypertext Transfer Protocol (HTTP) Digest Authentication Using Authentication and Key Agreement (AKA)", RFC3310, September 2002.

[WAPCert] WAP-211-WAPCert, 22.5.2001: <http://www1.wapforum.org/tech/terms.asp?doc=WAP-211-WAPCert-20010522-a.pdf>

[WIM] WAP-260-WIM-20010712, 12.7.2001: <http://www1.wapforum.org/tech/documents/WAP-260-WIM-20010712-a.pdf>

[WPKI] WAP-217-WPKI, 24.4.2001: <http://www1.wapforum.org/tech/documents/WAP-217-WPKI-20010424-a.pdf>

[X.509] ITU-T Recommendation X.509 (1997) | ISO/IEC 9594-8:1997, "Information Technology - Open Systems Interconnection - The Directory: Authentication Framework", 1997.

[TR GAA]

3 Definitions, symbols and abbreviations

Delete from the above heading those words which are not applicable.

Subclause numbering depends on applicability and should be renumbered accordingly.

3.1 Definitions

For the purposes of the present document, the [following] terms and definitions [given in ... and the following] apply.

Definition format

<defined term>: <definition>.

example: text used to clarify abstract rules by applying them literally.

Subscriber certificate: a certificate issued to a subscriber. It contains subscriber's own public key and possibly other information such as subscriber's identity in some form.

CA certificate: A Certificate Authority signs all certificates that it issues with its private key. The corresponding Certificate Authority public key is itself contained within a certificate, called a CA Certificate.

3.2 Symbols

For the purposes of the present document, the following symbols apply:

Symbol format

<symbol> <Explanation>

3.3 Abbreviations

For the purposes of the present document, the following abbreviations apply:

Abbreviation format

<ACRONYM>	<Explanation>
AK	Anonymity Key
AKA	Authentication and Key Agreement
BSF	Bootstrapping server functionality. BSF is hosted in a network element under the control of an MNO.
BSP	BootStrapping Procedure
CA	Certificate Authority
CMP	Certificate Management Protocols
HSS	Home Subscriber System
IK	Integrity Key
MNO	Mobile network operator
NAF	Operator-controlled network application function functionality. NAF is hosted in a network element under the control of an MNO.
PKCS	Public-Key Cryptography Standards
PKI	Public Key Infrastructure
SCP	Subscriber Certificate Procedure
UE	User Equipment

4 Support for Subscriber Certificates

4.1 Introduction

Digital signatures can be used, for instance, to secure mobile commerce, service authorization and accounting. But digital signature by itself is not enough; there is need of a global support for authorization and charging. Thus 3GPP shall use global and secure authorization and charging infrastructure of mobile networks to support local architecture for digital signatures.

Subscriber certificates provide a migration path towards global Public Key Infrastructure (PKI). Local architecture for digital signatures can be deployed incrementally; an operator can choose to deploy independently of the others. On the other hand, the existence of subscribers and service providers that use digital signatures makes it easier to build global PKI.

3GPP systems shall issue subscriber certificates in order to authorize and account for service usage both in home and in visited network. This requires specification of:

1. Procedures to issue temporary or long-term certificates to subscribers.
2. Standard format of certificates and digital signatures, e.g. re-using wireless PKI.

The mechanism shall allow a cost efficient implementation of the security support of the UE. It will also enable a user's anonymity towards the service provider, whilst the user who invoking the service, can be identified by the network.

Subscriber certificates support services whose provision mobile operator assists, as well as services that mobile operator provides. There is no need to standardize those services. Also, the communication between service provider and the operator (in the role of certificate issuer) need not be standardized.

4.2 Requirements and principles for issuing subscriber certificates

The following prerequisites for issuing of subscriber certificates exists:

- The shared key material is available for the UE application, which does the certificate request and operator CA certificate retrieval.
- The issuing of requested certificate is allowed according to subscriber profile. NAF is responsible for performing this check before issuing the subscriber certificate.

4.2.1 Requirements on ~~protocol B~~Ua interface

The requirements for ~~protocol B~~Ua interface are:

- UE is able to request for subscriber's certification from the PKI portal that plays the role of the NAF over a network connection.
- NAF is able to authenticate UE's certificate request.
- UE is able to acquire an operator's CA certificate over the network connection.
- UE is able to authenticate the NAF response (i.e., operator CA certificate delivery).
- The procedure is independent of the access network used.
- The NAF should have access to the subscriber profile to check the certification policies. This means that the ~~protocol D~~Zn interface (cf. ~~clause 4.2.9~~[TS GBA]) should have support for retrieving a subset of the subscriber profile.
- The response and delivery of certificate to UE must be within a few seconds after the initial certification request.

4.2.2 Requirements on ~~protocol~~DZn interface

The requirements for ~~protocol~~DZn interface are:

- NAF is able to communicate securely with a subscriber's BSF.
- The NAF is able to send a key material request to the BSF.
- The BSF is able to send the requested key material to the NAF.
- The NAF is able to get the subscriber profile from BSF.

Editor's note: in later phases there is an additional requirement that the NAF and the BSF may be in different operators' networks.

4.3 Certificate issuing

Annex <A> (informative): Support for subscriber certificates based on bootstrapping

A.1 Introduction

This annex describes how operators issue the subscriber certificates and deliver operator CA certificates to subscribers.

A.2 Additional requirements and principles

A.2.1 Usage of Bootstrapping

Issuing procedures of the subscriber certificate and operator CA certificate shall be secured by using shared keys obtained from bootstrapping function.

A.2.2 Access independence

Subscriber certificate and operator CA certificate issuing procedures are access independent. Certificate issuing procedures require IP connectivity from UE.

A.2.3 Roaming and service network support

The roaming subscriber shall be able to request subscriber certificates and operator CA certificates from home network.

Editor's note: Certificate requests to any than home network may be supported in later phase of the present specification.

A.2.4 Home operator control

Home operator shall be able to control the issuing of subscriber certificates. The control includes to whom the certificates are allowed to issue and the types of issued certificates.

Operator control is supported by information in the subscriber profile. For each type of subscriber certificate, i.e. for different keyUsage in WAP Certificate and CRL Profile, subscriber profile shall contain a flag that allows or disallows the issuing of that type of certificate to subscriber.

Editor's note: Currently two keyUsage values are envisioned: authentication and signing.

Delivery of operator CA certificates is always allowed.

Editor's note: For the first phase of standardisation, only the case is considered where bootstrapping server functionality and network application function are located in the same network as the HSS. Thus is the first phase the home network control does not require any communication between home and visited networks. In later phases, when also visited network may issue certificates, standardized way of transferring the control information from home network to visited network is needed.

A.2.5 Charging principles

The operator shall be capable to charge issuing of subscriber certificates or delivery of operator CA certificates.

Editor's note: The charging mechanism and whether it needs to be standardized in 3GPP is FFS.

A.2.6 Subscriber Certificate Profile

Subscriber certificate profile shall be based on WAP Certificate and CRL Profile [WAPCert], which in turn is based on profiles defined in [RFC3280] and [X.509]. A certificate profile defines the format and semantics of certificates in a specific context. WAP Certificate and CRL profiles specification defines four certificate profiles: two user certificate profiles – one for authentication and the other for non-repudiation purposes, server certificate profile for authentication, and authorization certificate profile (i.e., CA certificate). Since subscriber certificates are issued to users, and since services need CA certificate to validate subscriber certificates, the relevant WAP certificate profiles to be used with subscriber certificate profiles are the user certificate profiles, and CA certificate profile.

Editor's note: Applicability of other certificate profile specifications, e.g. RFC 3281, ETSI QC profile is FFS.

The following certificate extensions shall be filled with the information given by the UE in the certification request:

- Intended certificate usage (i.e., using keyUsage and/or extKeyUsage extensions [WAPCert]).
- Subscriber identities (i.e., subject name field, and possible additional identities defined in the subjectAltName extension [WAPCert]). Operator CA shall authorize each suggested subscriber identity.
- Proof of key origin (i.e., keyGenAssertion). Operator CA shall verify the proof of key origin if it is presented.

Note: It is not mandatory for Operator CA to insert these suggested extensions by UE to the certificate. Rather, Operator CA shall issue certificates based on its certification policies. It may write a certification practice statement (CPS) [RFC2527], where it describes the general requirements and steps taken during the certificate issuing.

A.2.7 Service Discovery

The addresses of bootstrapping server and PKI portal may be pre-configured to the UE or UICC. The possible service discovery or over-the-air configuration mechanism are FFS.

Editor's note: For the first phase of standardisation, when bootstrapping server functionality and network application function are always located in home network, therefore pre-configuration of addresses is sufficient. In later phases, however, when UE needs to address of PKI Portal in the visited network, more flexible is needed in the solution.

A.3 Certificate issuing architecture

A.3.1 Reference model

Figure 1 below shows a simple network model of the entities involved in the certificate issuing, and the protocols used between the network entities.

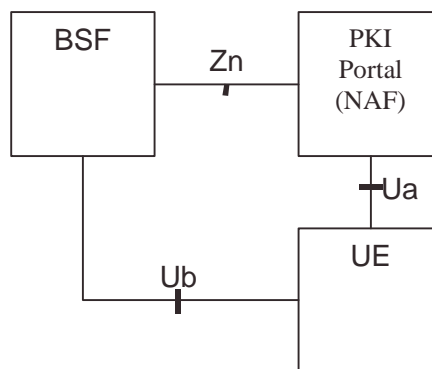

Figure 1: Simple network model for certificate issuing.

A.3.2 Network elements

A.3.2.1 PKI Portal

A PKI Portal shall issue a certificate for UE and deliver an operator CA certificate. In both cases, requests and responses are protected by shared key material that has been previously established between UE and a BSF

In PKI terms, the PKI portal is a Registration Authority (RA) who authenticates the certification request based on cellular subscription (using interface Ub). PKI Portal may also function as a Certification Authority (CA) who will issue certificates. However, this task may also be done in an existing PKI infrastructure towards which the PKI Portal would function as a RA only, and the CA would be in the PKI infrastructure.

A.3.2.2 Bootstrapping Server Function

The bootstrapping server function (BSF) shall support the PKI portal by providing the authentication (e.f. section 4.2.2.1 [TS GBA]) and subscriber profile information (i.e., whether subscriber is able to enrol a certain types of subscriber certificate).

A.3.2.3 UE

The required new functionality from UE is the support of the ~~protocol~~ Bu interface (i.e. certification enrolment protocol) that is protected using the shared keys established during bootstrapping function.

In addition UE may have the capability to generate public and private key pairs, store the private key part to a non-volatile memory (e.g., in UICC), and protect the usage of the private key part (e.g., with a PIN).

A.3.3 Reference points

A.3.3.1 ~~B~~u interface

A.3.3.1.1 General description

In the certificate issuing, ~~protocol~~ Bu interface is used to for:

- The operator CA certifying subscriber's public keys in format of certificates, and
- The delivery of the Operator CA certificate to the UE.

During subscriber certificate issuing, UE may request a certification of a public key. The supported request formats shall include PKCS#10. It is used to encapsulate the public key and other attributes (i.e., subject name, intended key usage, etc.). The request is transported from the UE to the PKI Portal using ~~protocol~~ Bu interface. Upon receiving the certification request, PKI portal will certify the public key according to its own certification practice policies and subscriber profile which is fetched through BSF from HSS. If PKI Portal decides to certify the public key, it will digitally sign it, and generate the corresponding certificate, which is returned from PKI Portal to the UE, using ~~protocol~~ Bu interface.

During operator CA certificate delivery, the UE may request the PKI Portal to deliver operator CA's certificate. In the corresponding response, the PKI Portal will deliver the CA's certificate to the UE. Since the operator's CA certificate is typically a self-signed certificate and the validation of certificates signed by this CA is based on this particular CA certificate, it needs to be delivered over authenticated and secured channel.

Authentication, integrity protection, and possibly encryption of the ~~protocol~~ Bu interface messages are based on the BSF generated shared secret.

A.3.3.1.2 Functionality and protocols

Editor's note: From five alternatives investigated in S3-030073 and S3-030036, only the following two have been agreed to add to the present document as potential solutions.

A.3.3.1.2.1 PKCS#10 with HTTP Digest Authentication

HTTP Digest Authentication scheme [RFC2617] may be done with BSF shared key material the following way.

- UE makes a blank HTTP request to the NAF
- NAF returns a HTTP response with “WWW-Authenticate” header indicating that HTTP Digest Authentication is needed. Quality of protection (qop) attribute is set to “auth-int” meaning that the content in following HTTP requests and responses are integrity protected.
- UE calculates the correct response to the “WWW-Authenticate” header using the *identifier* (base64 encoded) as the username and the session key K (base64 encoded) as the password. The session key K is has been previously derived from the key material Ks that resulted from running ~~protocol~~ [A-Ub interface](#). HTTP Digest Authentication parameters are returned in the “Authorization” header of HTTP Response.
- NAF validates the “Authorization” header and upon successful validation, performs the requested task. In the corresponding HTTP response, NAF calculates the relevant values for “Authentication-Info” header, which is used to authenticate and integrity protect the NAF response.
- UE validates the “Authentication-Info” header and upon successful validation, accepts the payload in the HTTP response.

A PKCS#10 [PKCS10] based certification request is sent to the CA NAF using a HTTP POST request, which MUST be authenticated and integrity protected by HTTP Digest Authentication.

Certificate is delivered using the HTTP response, which MAY be authenticated and integrity protected by HTTP Digest Authentication. The content-type of the HTTP response is either “application/x-x509-user-cert” or “application/vnd.wap.cert-response” as specified in [WPKI].

The UE requests a CA certificate delivery by sending a plain HTTP GET request with specific parameters in the request URI . The request MAY be authenticated and integrity protected by HTTP Digest Authentication.

CA certificate is delivered using the HTTP response, which MUST be authenticated and integrity protected by HTTP Digest Authentication. The content-type of the HTTP response would be “application/x-x509-ca-cert”. Note that the user should always be notified when a new CA certificate is taken into use.

A.3.3.1.2.2 Certificate Management Protocols (CMP)

Certificate Management Protocols (CMP) [RFC2510] describes a set of messages that can be used between different PKI components, e.g., between the CA and the end entity as well as between two CAs. The messages used in the specification have the following general message structure called PKIMessage. PKIMessage contains four fields: PKIHeader, PKIBody, optional PKIProtection, and optional certificate list. The PKIHeader contains information, which is common to many PKI messages. The PKIBody contains the message-specific information. The PKIProtection, when used, contains bits that protect the PKI message. The certificate list can contain certificates that may be useful to the recipient. [RFC2510]

In CMP, authentication is achieved by the PKI issuing the end entity with a secret value (initial authentication key) and reference value (used to identify the transaction) via some out-of-band means. The initial authentication key can then be used to protect relevant PKI messages (see chapters 2.2.1.2. and 3.1.3 of [RFC2510] for details). Also a replay prevention mechanism is specified.

The supported certificate request formats are PKCS#10 [PKCS10] and CRMF [RFC 2511]. The certificate request is inserted in the PKIBody field of the PKIMessage. The response to the certificate request is a CertRespMessage that is inserted in the PKIBody field of the PKIMessage. The CertRespMessage contains the status of the response, and if certificate request was approved the certificate itself. CMP supports also a certification procedure where the key generation happens in the CA rather the in the UE. However, CMP states that this procedure is only optionally implemented by CAs. See more details in [RFC2510].

CMP defines data structures, which can support mechanism where the CA is able to publish its current public key using self-signed certificates that are distributed via some “out-of-band” means. Alternatively the self-signed CA certificate can be published on a directory server and a hash of the certificate can be distributed via some out-of-band means. The idea is that anyone who has securely received a hash value can verify the authenticity of the CA certificate. The structure of such a self-signed out-of-band certificate or hash is specified in the RFC. However, the way how the CA

publishes the self-signed certificate and/or securely delivers the hash value is considered out-of-scope for CMP (see chapter 3.2.5 of [RFC2510]).

A.4 Certificate issuing procedure

A.4.1 Certificate issuing

Editor's note: From five alternatives investigated in S3-030073 and S3-030036, only the following two have been agreed to add to the present document as potential solutions.

A.4.1.1 Certificate issuing using PKCS#10 with HTTP Digest Authentication

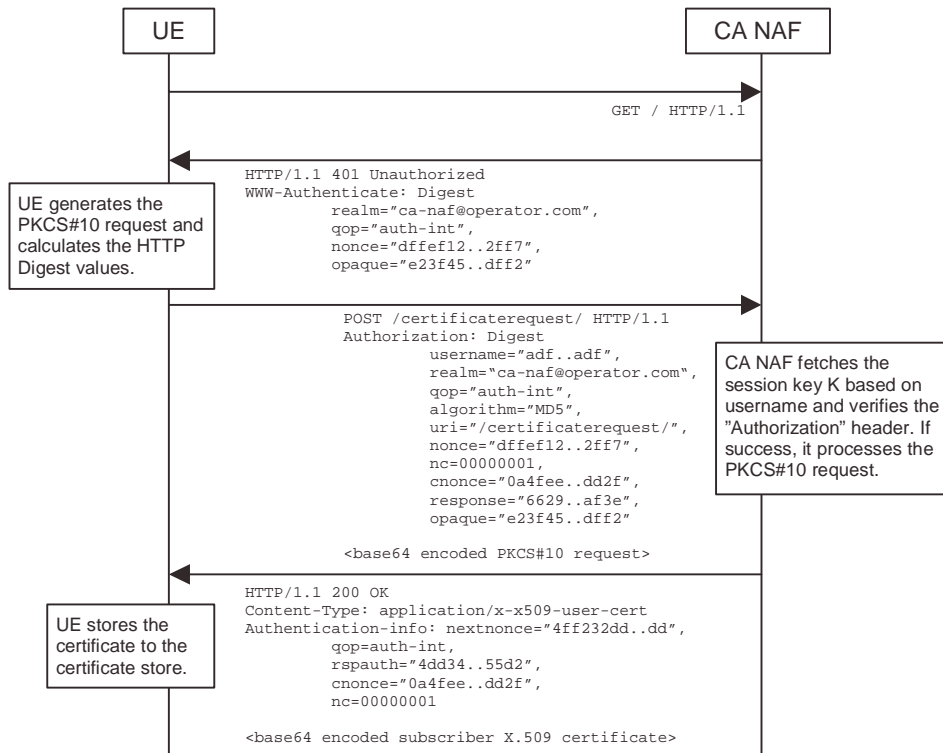

Figure 2: Certificate request using PKCS#10 with HTTP Digest Authentication.

The sequence diagram above describes the certificate request when using PKCS#10 with HTTP Digest. The sequence starts with an empty HTTP request to CA NAF. The CA NAF responds with HTTP response code 401 “Unauthorized” which contains a WWW-Authenticate header. The header instructs the UE to use HTTP Digest authentication.

The UE generates a PKCS#10 request with the subject name, public key, additional attributes and extensions. Then it will generate the HTTP request by calculating the Authorization header values using the identifier it received from the BSF as username and the session key K.

When CA NAF receives the request, it will verify the Authorization header by fetching the session key K from the bootstrapping server using the identifier, then calculating the corresponding digest values using K, and finally comparing the calculated values with the received values in the Authorization header. If the verification succeeds, the incoming PKCS#10 request is taken in for further processing. If the CA NAF is actually a registration authority (RA NAF), the PKCS#10 request is forwarded to CA using any protocol available (e.g., CMC or CMP). After the PKCS#10 request has been processed and a certificate has been created, the new certificate is returned to the CA NAF. It will generate a HTTP response containing the certificate. The CA NAF may use session key K to integrity protect and authenticate the response.

When UE receives the subscriber certificate, it is stored to local certificate management system.

NOTE: On board key generation is already defined in the WIM specification [WIM] issued by Open Mobile Alliance (OMA) group."

A.4.1.2 Certificate issuing with CMP

CMP defines two methods to do the certificate issuing: basic authenticated scheme and centralized scheme. In the basic authenticated scheme the key generation happens in the UE while in the centralized scheme the key generation is done in the CA (or RA). CMP states that the support for the basic authenticated scheme for certificate issuing is mandatory for CAs while the support for the centralized scheme is optional. See more details in chapters 2.2 and B8 of [RFC2510].

The messages can be transported using various methods such as file based protocol, (such files can be used to transport PKI messages e.g. using FTP, HTTP, email etc.), direct TCP-based management protocol, management protocol via e-mail, and management protocol via HTTP mentioned in section 5 of [RFC2510].

A.4.1.2.1 Basic authenticated scheme

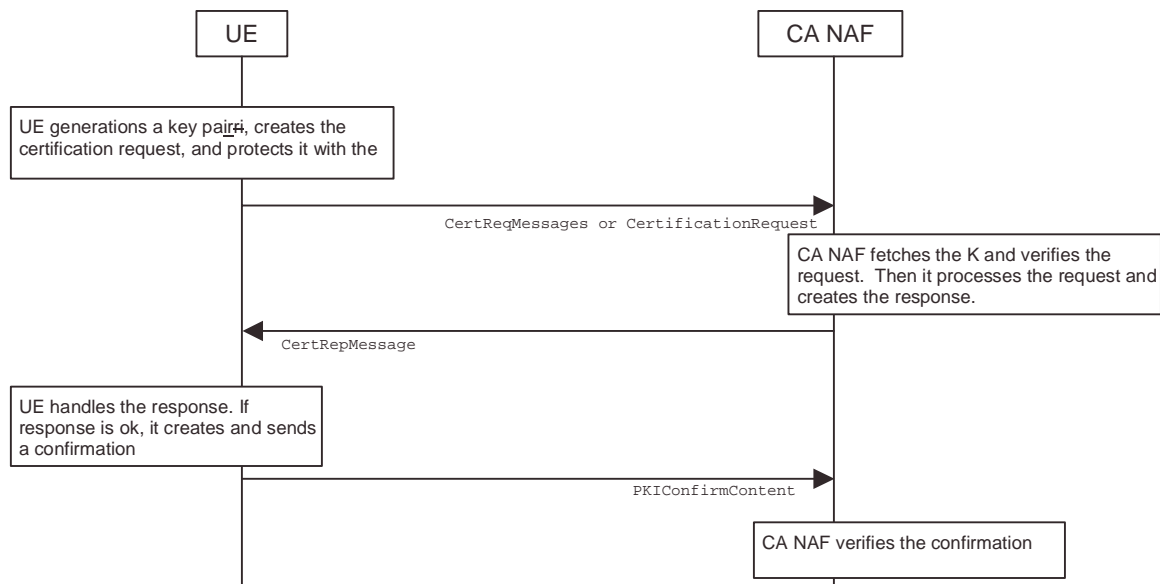

Figure 3: Certificate request using basic authentication scheme of CMP.

The sequence diagram above describes the certificate request and delivery procedure when using CMP and basic authenticated scheme [RFC2510]. The sequence starts with UE generating a key pair, creating the certificate request message format (CRMF) message, inserting it to CertReqMessages message, and integrity protecting this message with the initial authentication key (IAK). The session key K, which has been derived earlier using [protocol-A-Ub interface](#), can be used as IAK.

The certificate request message is sent to CA NAF who fetches the corresponding K based on the identifier received in the request. CA NAF verifies the request with the K. If the verification succeeds, the CA NAF processes the request, i.e. generates and signs the certificate and sends the certification response to the UE.

UE verifies the certificate response message with the K. If the message verification is successful, the issued certificate is stored to the device, and UE sends a confirmation message to the CA NAF.

CA NAF verifies the confirmation message. If the verification fails or CA NAF never receives the confirmation message, CA NAF must revoke the newly issued certificate if it has been already published.

A.4.1.2.2 Centralized scheme initiated by the UE

The centralized scheme provides a mechanism where the public/private key pair is generated outside the UE, e.g. by the CA.

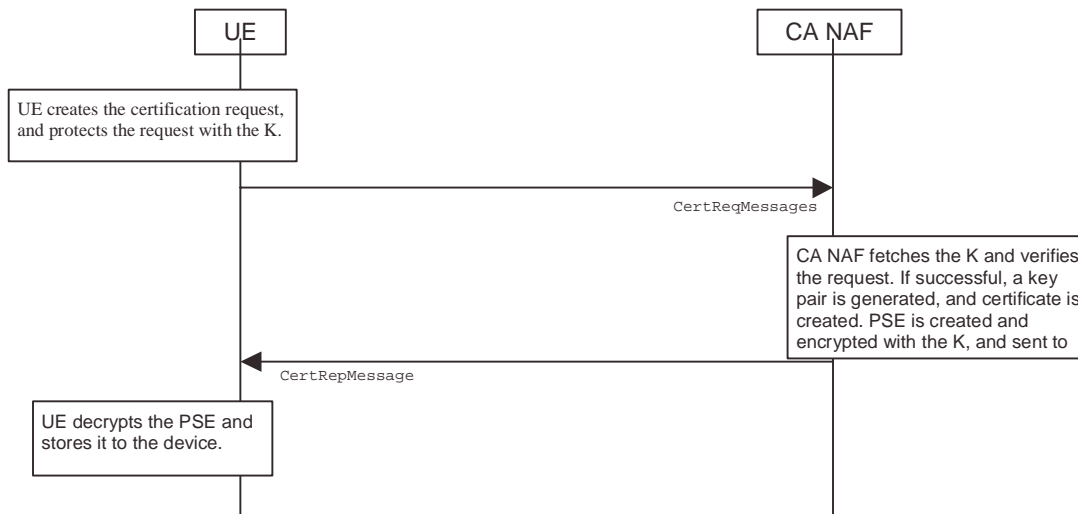

Figure 4: Certificate request using centralized scheme of CMP.

The sequence diagram above describes the delivery mechanism initiated by the UE using CMP in centralized scheme. This scheme is optional in CMP [RFC2510]. The sequence starts with the UE by creating CertReqMessages message with certain parameters, and protecting this message with initial authentication key (IAK). The session key K, which has been derived earlier using [protocol A-Ub interface](#), can be used as IAK.

The certificate request message is sent to CA NAF who fetches the corresponding K based on the identifier received in the request. CA NAF verifies the request with the K. If the verification succeeds, CA NAF processes the request, i.e. generates a key pair, generates and signs the certificate, and sends the certification response containing the Personal Security Environment (PSE) encrypted to the UE. PSE typically contains the generated private key and newly issued certificate with corresponding public key.

UE verifies the certificate response message with the K. If the message verification is successful, the issued PSE is decrypted and stored to the device. A confirmation message is not sent in the centralized scheme.

A.4.2 CA Certificate delivery

A.4.2.1 CA Certificate delivery with HTTP Digest Authentication

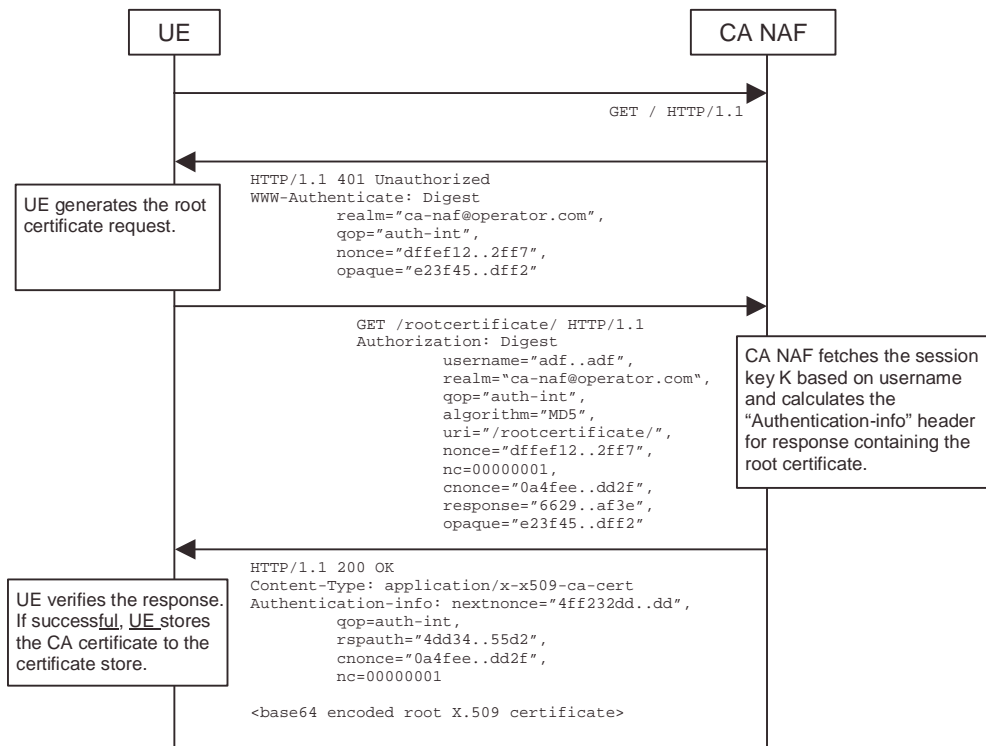

Figure 5: CA certificate delivery with HTTP Digest authentication.

The sequence diagram above describes the CA certificate delivery when using HTTP Digest authentication. The sequence starts with an empty HTTP request to CA NAF. The CA NAF responds with HTTP response code 401 "Unauthorized" which contains a WWW-Authenticate header. The header instructs the UE to use HTTP Digest for authentication.

The UE generates another empty HTTP request for requesting the CA certificate. The Authorization header values are calculated using the identifier and the session key K. The authentication of this HTTP request is not necessary, but it is done in order to follow HTTP Digest authentication specification. Also, the identifier needs to be transported to the CA, i.e. the NAF. A request of subscriber's certificate is specified in section A.4.1.1.

When CA NAF receives the request, it may verify the Authorization header by fetching the session key K from the bootstrapping server using the identifier. CA NAF will generate a HTTP response containing the CA certificate and use the session key K to authenticate and integrity protect the HTTP response using the Authentication-info header. Essentially, the response could also be other delivery protocol in HTTP format, e.g. PKCS#7 cryptographic message with content type signedData.

When UE receives the new CA certificate, it must validate the Authentication-info header. If validation succeeds, the user is notified that a new CA certificate is taken into use. If user accepts the new CA certificate, it is stored to the local certificate management system and marked as "trusted" CA certificate.

A.4.2.2 CA Certificate delivery with CMP

CMP defines only out-of-band method for delivering CA certificates. CA certificate may be delivered as part of the certificate request, where the response could contain certificates that may be useful to the recipient. It can contain the whole certificate chain (including the CA certificate). The root CA produces a "self-certificate" and also produces a fingerprint of its public key. End entities that acquire this fingerprint securely via some out-of-band means can then verify the CA's self-certificate and hence the other attributes contained therein.

A.5 Functionality in presence of pre-certified key pair

Editor's notes: Based on contribution S3-030037, it was agreed to add this part into the present document for ffs.

An alternative to securing certificate enrolment based on AKA and bootstrapping function is to secure certificate enrolment based on signatures made with pre-certified key in the UE. This alternative has been specified by Open Mobile Alliance (see section 7.3.4 of [WPKI]) and is thus out of scope of this specification. The functionality in presence of pre-certified key pair in the UE is explained below only briefly.

In this alternative solution, the UE equipped with a UICC, is previously issued with a pre-loaded, long lasting, public/private key pair from the home network. This phase would occur out of band, and would result in the UE possessing a long lasting key pair stored in the UICC for the purposes of certificate request authentication. Open Mobile Alliance (OMA) group offers standardized solutions by means of WPKI specification [WPKI] and WIM specification [WIM] for the storage and the use of long-lasting key pair. USIM and WIM are examples of applications on the UICC that can deal with the long-lasting keys.

The UE can issue a request for a certificate to the CA, signing the request with the long lasting private key. The certificate request itself could contain a newly generated public key that is to be certified by the CA. This assumes that the new key pair is generated in the UICC. Or it is also possible for the CA to generate the new key pair and send it (protected) to the UICC. Access control security for the pre-loaded long-lasting private key should be at least as good as for access control for USIM.

Two options can be envisaged. Though the public/private key pair is long lasting, the validity of the subscriber certificates issued to the UE could be short-lived. In this case the long lasting public/private key pair is used for PKI applications (e.g. in mobile-commerce) in combination with the short-lived certificates. Alternatively, the long lasting public/private key pair could come with a long-term certificate. The long-term private key would then have a restricted purpose, e.g. only to be used to authenticate subscriber certificate requests. The latter would be used to obtain another, short-lived certificate on a short-lived public/private key pair. It would then be the short-lived keys that could be used for e.g. m-commerce and other 3G PKI applications.

Annex <X> (informative): Change history

It is usual to include an annex (usually the final annex of the document) for specifications under TSG change control which details the change history of the specification using a table as follows:

Change history							
Date	TSG #	TSG Doc.	CR	Rev	Subject/Comment	Old	New
2003-10	SA3#30				<i>First draft TS: Support for Subscriber Certificates (SSC). Extracted from 33.109 sections 5 and Annex A.</i>		0.1.0
2003-10	SA3#30	S3-020536			<i>Further clarification on WAP Certificate and CRL profile.</i>		0.1.0
2003-10	SA3#30	S3-030537			<i>New interface names</i>		0.1.0

**3rd Generation Partnership Project;
Technical Specification Group Services and System Aspects;
Generic Authentication Architecture (GAA);
Support for Subscriber Certificates
(Release 6)**



The present document has been developed within the 3rd Generation Partnership Project (3GPPTM) and may be further elaborated for the purposes of 3GPP.

The present document has not been subject to any approval process by the 3GPP Organizational Partners and shall not be implemented. This Specification is provided for future development work within 3GPP only. The Organizational Partners accept no liability for any use of this Specification. Specifications and reports for implementation of the 3GPPTM system should be obtained via the 3GPP Organizational Partners' Publications Offices.

Remove GSM logo from the cover page for pure 3rd Generation documents.

Select keywords from list provided in specs database.

Keywords

<keyword[, keyword]>

3GPP

Postal address

3GPP support office address

650 Route des Lucioles - Sophia Antipolis
Valbonne - FRANCE
Tel.: +33 4 92 94 42 00 Fax: +33 4 93 65 47 16

Internet

<http://www.3gpp.org>

Copyright Notification

No part may be reproduced except as authorized by written permission.
The copyright and the foregoing restriction extend to reproduction in all media.

© 2002, 3GPP Organizational Partners (ARIB, CWTS, ETSI, T1, TTA, TTC).
All rights reserved.

Contents

Foreword.....	5
Introduction.....	5
1 Scope.....	6
2 References.....	6
3 Definitions, symbols and abbreviations.....	7
3.1 Definitions.....	7
3.2 Symbols.....	7
3.3 Abbreviations.....	7
4 Support for Subscriber Certificates.....	8
4.1 Introduction.....	8
4.2 Requirements and principles for issuing subscriber certificates.....	8
4.2.1 Usage of Bootstrapping.....	8
4.2.2 Access independence.....	8
4.2.3 Roaming and service network support.....	8
4.2.4 Home operator control.....	9
4.2.5 Charging principles.....	9
4.2.6 Subscriber Certificate Profile.....	9
4.2.7 Service Discovery.....	9
4.2.8 Requirements on Ua interface.....	10
4.2.9 Requirements on Zn interface.....	10
4.3 Certificate issuing architecture.....	10
4.3.1 Reference model.....	10
4.3.2 Network elements.....	11
4.3.2.1 PKI Portal.....	11
4.3.2.2 Bootstrapping Server Function.....	11
4.3.2.3 UE.....	11
4.3.3 Reference points.....	11
4.3.3.1 Ua interface.....	11
4.3.3.1.1 General description.....	11
4.3.3.1.2 Functionality and protocols.....	11
4.3.3.1.2.1 PKCS#10 with HTTP Digest Authentication.....	12
4.3.3.1.2.2 Certificate Management Protocols (CMP).....	12
4.4 Certificate issuing procedure.....	13
4.4.1 Certificate issuing.....	13
4.4.1.1 Certificate issuing using PKCS#10 with HTTP Digest Authentication.....	13
4.4.1.2 Certificate issuing with CMP.....	14
4.4.1.2.1 Basic authenticated scheme.....	14
4.4.1.2.2 Centralized scheme initiated by the UE.....	14
4.4.2 CA Certificate delivery.....	16
4.4.2.1 CA Certificate delivery with HTTP Digest Authentication.....	16
4.4.2.2 CA Certificate delivery with CMP.....	16
4.5 Functionality in presence of pre-certified key pair.....	17
Annex <X> (informative): Change history.....	27
Foreword.....	4
Introduction.....	4
1 Scope.....	5
2 References.....	5
3 Definitions, symbols and abbreviations.....	6
3.1 Definitions.....	6
3.2 Symbols.....	6

3.3	Abbreviations	6
4	Support for Subscriber Certificates	7
4.1	Introduction	7
4.2	Requirements and principles for issuing subscriber certificates	7
4.2.1	Requirements on Ua interface	7
4.2.2	Requirements on Zn interface	8
4.3	Certificate issuing	8
Annex <A> (informative): Support for subscriber certificates based on bootstrapping		9
A.1	Introduction	9
A.2	Additional requirements and principles	9
A.2.1	Usage of Bootstrapping	9
A.2.2	Access independence	9
A.2.3	Roaming and service network support	9
A.2.4	Home operator control	9
A.2.5	Charging principles	9
A.2.6	Subscriber Certificate Profile	10
A.2.7	Service Discovery	10
A.3	Certificate issuing architecture	10
A.3.1	Reference model	10
A.3.2	Network elements	11
A.3.2.1	PKI Portal	11
A.3.2.2	Bootstrapping Server Function	11
A.3.2.3	UE11	
A.3.3	Reference points	11
A.3.3.1	Ua interface	11
A.3.3.1.1	General description	11
A.3.3.1.2	Functionality and protocols	11
A.3.3.1.2.1	PKCS#10 with HTTP Digest Authentication	12
A.3.3.1.2.2	Certificate Management Protocols (CMP)	12
A.4	Certificate issuing procedure	13
A.4.1	Certificate issuing	13
A.4.1.1	Certificate issuing using PKCS#10 with HTTP Digest Authentication	13
A.4.1.2	Certificate issuing with CMP	14
A.4.1.2.1	Basic authenticated scheme	14
A.4.1.2.2	Centralized scheme initiated by the UE	14
A.4.2	CA Certificate delivery	16
A.4.2.1	CA Certificate delivery with HTTP Digest Authentication	16
A.4.2.2	CA Certificate delivery with CMP	16
A.5	Functionality in presence of pre-certified key pair	17
Annex <X> (informative): Change history		18

Foreword

This Technical Specification has been produced by the 3rd Generation Partnership Project (3GPP).

The contents of the present document are subject to continuing work within the TSG and may change following formal TSG approval. Should the TSG modify the contents of the present document, it will be re-released by the TSG with an identifying change of release date and an increase in version number as follows:

Version x.y.z

where:

- x the first digit:
 - 1 presented to TSG for information;
 - 2 presented to TSG for approval;
 - 3 or greater indicates TSG approved document under change control.
- y the second digit is incremented for all changes of substance, i.e. technical enhancements, corrections, updates, etc.
- z the third digit is incremented when editorial only changes have been incorporated in the document.

Introduction

This clause is optional. If it exists, it is always the second unnumbered clause.

1 Scope

This clause shall start on a new page.

The present document ...

2 References

The following documents contain provisions which, through reference in this text, constitute provisions of the present document.

- References are either specific (identified by date of publication, edition number, version number, etc.) or non-specific.
- For a specific reference, subsequent revisions do not apply.
- For a non-specific reference, the latest version applies. In the case of a reference to a 3GPP document (including a GSM document), a non-specific reference implicitly refers to the latest version of that document *in the same Release as the present document*.

[<seq>] <doctype> <#>[([up to and including]{yyyy[-mm]|V<a[.b[.c]]>}[onwards]): "<Title>".

[1] 3GPP TR 41.001: "GSM Release specifications".

[2] 3GPP TR 21.912 (V3.1.0): "Example 2, using fixed text".

[3] 3GPP TS 31.102: "Characteristics of the USIM Application".

[4] 3GPP TS 33.102: "Security Architecture".

[PKCS10] "PKCS#10 v1.7: Certification Request Syntax Standard", RSA Laboratories, May 2000.

[RFC2510] Adams C., Farrell S., "Internet X.509 Public Key Infrastructure Certificate Management Protocols", RFC 2510, March 1999.

[RFC2511] Myers M., et al., "Internet X.509 Certificate Request Message Format", RFC 2511, March 1999.

[RFC2527] Chokhani S., et al, "Internet X.509 Public Key Infrastructure Certificate Policy and Certification Practices Framework", RFC 2527, March 1999.

[RFC2617] Franks J., et al, "HTTP Authentication: Basic and Digest Access Authentication", RFC 2617, June 1999.

[RFC3280] Housley R., et al, "Internet X.509 Public Key Infrastructure Certificate and Certificate Revocation List (CRL) Profile", RFC 3280, April 2002.

[RFC 3310] A. Niemi, et al, "Hypertext Transfer Protocol (HTTP) Digest Authentication Using Authentication and Key Agreement (AKA)", RFC3310, September 2002.

[WAPCert] WAP-211-WAPCert, 22.5.2001: <http://www1.wapforum.org/tech/terms.asp?doc=WAP-211-WAPCert-20010522-a.pdf>

[WIM] WAP-260-WIM-20010712, 12.7.2001: <http://www1.wapforum.org/tech/documents/WAP-260-WIM-20010712-a.pdf>

[WPKI] WAP-217-WPKI, 24.4.2001: <http://www1.wapforum.org/tech/documents/WAP-217-WPKI-20010424-a.pdf>

[X.509] ITU-T Recommendation X.509 (1997) | ISO/IEC 9594-8:1997, "Information Technology - Open Systems Interconnection - The Directory: Authentication Framework", 1997.

[TR GAA]

3 Definitions, symbols and abbreviations

Delete from the above heading those words which are not applicable.

Subclause numbering depends on applicability and should be renumbered accordingly.

3.1 Definitions

For the purposes of the present document, the [following] terms and definitions [given in ... and the following] apply.

Definition format

<defined term>: <definition>.

example: text used to clarify abstract rules by applying them literally.

Subscriber certificate: a certificate issued to a subscriber. It contains subscriber's own public key and possibly other information such as subscriber's identity in some form.

CA certificate: A Certificate Authority signs all certificates that it issues with its private key. The corresponding Certificate Authority public key is itself contained within a certificate, called a CA Certificate.

3.2 Symbols

For the purposes of the present document, the following symbols apply:

Symbol format

<symbol> <Explanation>

3.3 Abbreviations

For the purposes of the present document, the following abbreviations apply:

Abbreviation format

<ACRONYM>	<Explanation>
AK	Anonymity Key
AKA	Authentication and Key Agreement
BSF	Bootstrapping server functionality. BSF is hosted in a network element under the control of an MNO.
BSP	BootStrapping Procedure
CA	Certificate Authority
CMP	Certificate Management Protocols
HSS	Home Subscriber System
IK	Integrity Key
MNO	Mobile network operator
NAF	Operator-controlled network application function functionality. NAF is hosted in a network element under the control of an MNO.
PKCS	Public-Key Cryptography Standards
PKI	Public Key Infrastructure
SCP	Subscriber Certificate Procedure
UE	User Equipment

4 Support for Subscriber Certificates

4.1 Introduction

Digital signatures can be used, for instance, to secure mobile commerce, service authorization and accounting. But digital signature by itself is not enough; there is need of a global support for authorization and charging. Thus 3GPP shall use global and secure authorization and charging infrastructure of mobile networks to support local architecture for digital signatures.

Subscriber certificates provide a migration path towards global Public Key Infrastructure (PKI). Local architecture for digital signatures can be deployed incrementally; an operator can choose to deploy independently of the others. On the other hand, the existence of subscribers and service providers that use digital signatures makes it easier to build global PKI.

3GPP systems shall issue subscriber certificates in order to authorize and account for service usage both in home and in visited network. This requires specification of:

1. Procedures to issue temporary or long-term certificates to subscribers.
2. Standard format of certificates and digital signatures, e.g. re-using wireless PKI.

The mechanism shall allow a cost efficient implementation of the security support of the UE. It will also enable a user's anonymity towards the service provider, whilst the user who invoking the service, can be identified by the network.

Subscriber certificates support services whose provision mobile operator assists, as well as services that mobile operator provides. There is no need to standardize those services. Also, the communication between service provider and the operator (in the role of certificate issuer) need not be standardized.

4.2 Requirements and principles for issuing subscriber certificates

The following prerequisites for issuing of subscriber certificates exists:

- The shared key material is available for the UE application, which does the certificate request and operator CA certificate retrieval.
- The issuing of requested certificate is allowed according to subscriber profile. NAF is responsible for performing this check before issuing the subscriber certificate.

4.2.1 Usage of Bootstrapping

Issuing procedures of the subscriber certificate and operator CA certificate shall be secured by using shared keys obtained from bootstrapping function.

4.2.2 Access independence

Subscriber certificate and operator CA certificate issuing procedures are access independent. Certificate issuing procedures require IP connectivity from UE.

4.2.3 Roaming and service network support

The roaming subscriber shall be able to request subscriber certificates and operator CA certificates from home network.

Editor's note: Certificate requests to any than home network may be supported in later phase of the present specification.

4.2.4 Home operator control

Home operator shall be able to control the issuing of subscriber certificates. The control includes to whom the certificates are allowed to issue and the types of issued certificates.

Operator control is supported by information in the subscriber profile. For each type of subscriber certificate, i.e. for different keyUsage in WAP Certificate and CRL Profile, subscriber profile shall contain a flag that allows or disallows the issuing of that type of certificate to subscriber.

Editor's note: Currently two keyUsage values are envisioned: authentication and signing.

Delivery of operator CA certificates is always allowed.

Editor's note: For the first phase of standardisation, only the case is considered where bootstrapping server functionality and network application function are located in the same network as the HSS. Thus is the first phase the home network control does not require any communication between home and visited networks. In later phases, when also visited network may issue certificates, standardized way of transferring the control information from home network to visited network is needed.

4.2.5 Charging principles

The operator shall be capable to charge issuing of subscriber certificates or delivery of operator CA certificates.

Editor's note: The charging mechanism and whether it needs to be standardized in 3GPP is FFS.

4.2.6 Subscriber Certificate Profile

Subscriber certificate profile shall be based on WAP Certificate and CRL Profile [WAPCert], which in turn is based on profiles defined in [RFC3280] and [X.509]. A certificate profile defines the format and semantics of certificates in a specific context. WAP Certificate and CRL profiles specification defines four certificate profiles: two user certificate profiles – one for authentication and the other for non-repudiation purposes, server certificate profile for authentication, and authorization certificate profile (i.e., CA certificate). Since subscriber certificates are issued to users, and since services need CA certificate to validate subscriber certificates, the relevant WAP certificate profiles to be used with subscriber certificate profiles are the user certificate profiles, and CA certificate profile.

Editor's note: Applicability of other certificate profile specifications, e.g. RFC 3281, ETSI QC profile is FFS.

The following certificate extensions shall be filled with the information given by the UE in the certification request:

- Intended certificate usage (i.e., using keyUsage and/or extKeyUsage extensions [WAPCert]).
- Subscriber identities (i.e., subject name field, and possible additional identities defined in the subjectAltName extension [WAPCert]). Operator CA shall authorize each suggested subscriber identity.
- Proof of key origin (i.e., keyGenAssertion). Operator CA shall verify the proof of key origin if it is presented.

Note: It is not mandatory for Operator CA to insert these suggested extensions by UE to the certificate. Rather, Operator CA shall issue certificates based on its certification policies. It may write a certification practice statement (CPS) [RFC2527], where it describes the general requirements and steps taken during the certificate issuing.

4.2.7 Service Discovery

The addresses of bootstrapping server and PKI portal may be pre-configured to the UE or UICC. The possible service discovery or over-the-air configuration mechanism are FFS.

Editor's note: For the first phase of standardisation, when bootstrapping server functionality and network application function are always located in home network, therefore pre-configuration of addresses is sufficient. In later phases, however, when UE needs to address of PKI Portal in the visited network, more flexible is needed in the solution.

4.2.18 Requirements on Ua interface

The requirements for Ua interface are:

- UE is able to request for subscriber's certification from the PKI portal that plays the role of the NAF over a network connection.
- NAF is able to authenticate UE's certificate request.
- UE is able to acquire an operator's CA certificate over the network connection.
- UE is able to authenticate the NAF response (i.e., operator CA certificate delivery).
- The procedure is independent of the access network used.
- The NAF should have access to the subscriber profile to check the certification policies. This means that the Zn interface [TS GBA] should have support for retrieving a subset of the subscriber profile.
- The response and delivery of certificate to UE must be within a few seconds after the initial certification request.

4.2.29 Requirements on Zn interface

The requirements for Zn interface are:

- NAF is able to communicate securely with a subscriber's BSF.
- The NAF is able to send a key material request to the BSF.
- The BSF is able to send the requested key material to the NAF.
- The NAF is able to get the subscriber profile from BSF.

Editor's note: in later phases there is an additional requirement that the NAF and the BSF may be in different operators' networks.

4.3 Certificate issuing architecture

4.3.1 Reference model

below shows a simple network model of the entities involved in the certificate issuing, and the protocols used between the network entities.

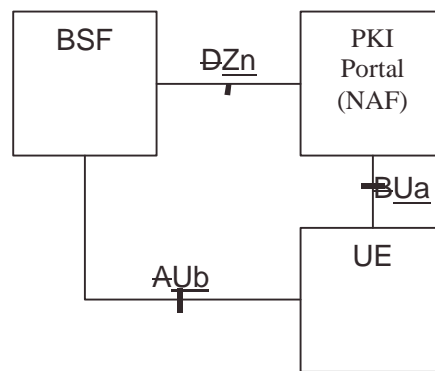

Figure 1: Simple network model for certificate issuing.

4.3.2 Network elements

4.3.2.1 PKI Portal

A PKI Portal shall issue a certificate for UE and deliver an operator CA certificate. In both cases, requests and responses are protected by shared key material that has been previously established between UE and a BSF

In PKI terms, the PKI portal is a Registration Authority (RA) who authenticates the certification request based on cellular subscription (using interface Ub). PKI Portal may also function as a Certification Authority (CA) who will issue certificates. However, this task may also be done in an existing PKI infrastructure towards which the PKI Portal would function as a RA only, and the CA would be in the PKI infrastructure.

4.3.2.2 Bootstrapping Server Function

The bootstrapping server function (BSF) shall support the PKI portal by providing the authentication (c.f. section 4.2.2.1) and subscriber profile information (i.e., whether subscriber is able to enrol a certain types of subscriber certificate).

4.3.2.3 UE

The required new functionality from UE is the support of the Ua interface (i.e. certification enrolment protocol) that is protected using the shared keys established during bootstrapping function.

In addition UE may have the capability to generate public and private key pairs, store the private key part to a non-volatile memory (e.g., in UICC), and protect the usage of the private key part (e.g., with a PIN).

4.3.3 Reference points

4.3.3.1 Ua interface

4.3.3.1.1 General description

In the certificate issuing, Ua interface is used to for:

- The operator CA certifying subscriber's public keys in format of certificates, and
- The delivery of the Operator CA certificate to the UE.

During subscriber certificate issuing, UE may request a certification of a public key. The supported request formats shall include PKCS#10. It is used to encapsulate the public key and other attributes (i.e., subject name, intended key usage, etc.). The request is transported from the UE to the PKI Portal using Ua interface. Upon receiving the certification request, PKI portal will certify the public key according to its own certification practice policies and subscriber profile which is fetched through BSF from HSS. If PKI Portal decides to certify the public key, it will digitally sign it, and generate the corresponding certificate, which is returned from PKI Portal to the UE, using Ua interface.

During operator CA certificate delivery, the UE may request the PKI Portal to deliver operator CA's certificate. In the corresponding response, the PKI Portal will deliver the CA's certificate to the UE. Since the operator's CA certificate is typically a self-signed certificate and the validation of certificates signed by this CA is based on this particular CA certificate, it needs to be delivered over authenticated and secured channel.

Authentication, integrity protection, and possibly encryption of the Ua interface messages are based on the BSF generated shared secret.

4.3.3.1.2 Functionality and protocols

Editor's note: From five alternatives investigated in S3-030073 and S3-030036, only the following two have been agreed to add to the present document as potential solutions.

4.3.3.1.2.1 PKCS#10 with HTTP Digest Authentication

HTTP Digest Authentication scheme [RFC2617] may be done with BSF shared key material the following way.

- UE makes a blank HTTP request to the NAF
- NAF returns a HTTP response with “WWW-Authenticate” header indicating that HTTP Digest Authentication is needed. Quality of protection (qop) attribute is set to “auth-int” meaning that the content in following HTTP requests and responses are integrity protected.
- UE calculates the correct response to the “WWW-Authenticate” header using the *identifier* (base64 encoded) as the username and the session key K (base64 encoded) as the password. The session key K is has been previously derived from the key material Ks that resulted from running Ub interface. HTTP Digest Authentication parameters are returned in the “Authorization” header of HTTP Response.
- NAF validates the “Authorization” header and upon successful validation, performs the requested task. In the corresponding HTTP response, NAF calculates the relevant values for “Authentication-Info” header, which is used to authenticate and integrity protect the NAF response.
- UE validates the “Authentication-Info” header and upon successful validation, accepts the payload in the HTTP response.

A PKCS#10 [PKCS10] based certification request is sent to the CA NAF using a HTTP POST request, which MUST be authenticated and integrity protected by HTTP Digest Authentication.

Certificate is delivered using the HTTP response, which MAY be authenticated and integrity protected by HTTP Digest Authentication. The content-type of the HTTP response is either “application/x-x509-user-cert” or “application/vnd.wap.cert-response” as specified in [WPKI].

The UE requests a CA certificate delivery by sending a plain HTTP GET request with specific parameters in the request URI . The request MAY be authenticated and integrity protected by HTTP Digest Authentication.

CA certificate is delivered using the HTTP response, which MUST be authenticated and integrity protected by HTTP Digest Authentication. The content-type of the HTTP response would be “application/x-x509-ca-cert”. Note that the user should always be notified when a new CA certificate is taken into use.

4.3.3.1.2.2 Certificate Management Protocols (CMP)

Certificate Management Protocols (CMP) [RFC2510] describes a set of messages that can be used between different PKI components, e.g., between the CA and the end entity as well as between two CAs. The messages used in the specification have the following general message structure called PKIMessage. PKIMessage contains four fields: PKIHeader, PKIBody, optional PKIProtection, and optional certificate list. The PKIHeader contains information, which is common to many PKI messages. The PKIBody contains the message-specific information. The PKIProtection, when used, contains bits that protect the PKI message. The certificate list can contain certificates that may be useful to the recipient. [RFC2510]

In CMP, authentication is achieved by the PKI issuing the end entity with a secret value (initial authentication key) and reference value (used to identify the transaction) via some out-of-band means. The initial authentication key can then be used to protect relevant PKI messages (see chapters 2.2.1.2. and 3.1.3 of [RFC2510] for details). Also a replay prevention mechanism is specified.

The supported certificate request formats are PKCS#10 [PKCS10] and CRMF [RFC 2511]. The certificate request is inserted in the PKIBody field of the PKIMessage. The response to the certificate request is a CertRespMessage that is inserted in the PKIBody field of the PKIMessage. The CertRespMessage contains the status of the response, and if certificate request was approved the certificate itself. CMP supports also a certification procedure where the key generation happens in the CA rather the in the UE. However, CMP states that this procedure is only optionally implemented by CAs. See more details in [RFC2510].

CMP defines data structures, which can support mechanism where the CA is able to publish its current public key using self-signed certificates that are distributed via some “out-of-band” means. Alternatively the self-signed CA certificate can be published on a directory server and a hash of the certificate can be distributed via some out-of-band means. The idea is that anyone who has securely received a hash value can verify the authenticity of the CA certificate. The structure of such a self-signed out-of-band certificate or hash is specified in the RFC. However, the way how the CA

publishes the self-signed certificate and/or securely delivers the hash value is considered out-of-scope for CMP (see chapter 3.2.5 of [RFC2510]).

4.4 Certificate issuing procedure

4.4.1 Certificate issuing

Editor's note: From five alternatives investigated in S3-030073 and S3-030036, only the following two have been agreed to add to the present document as potential solutions.

4.4.1.1 Certificate issuing using PKCS#10 with HTTP Digest Authentication

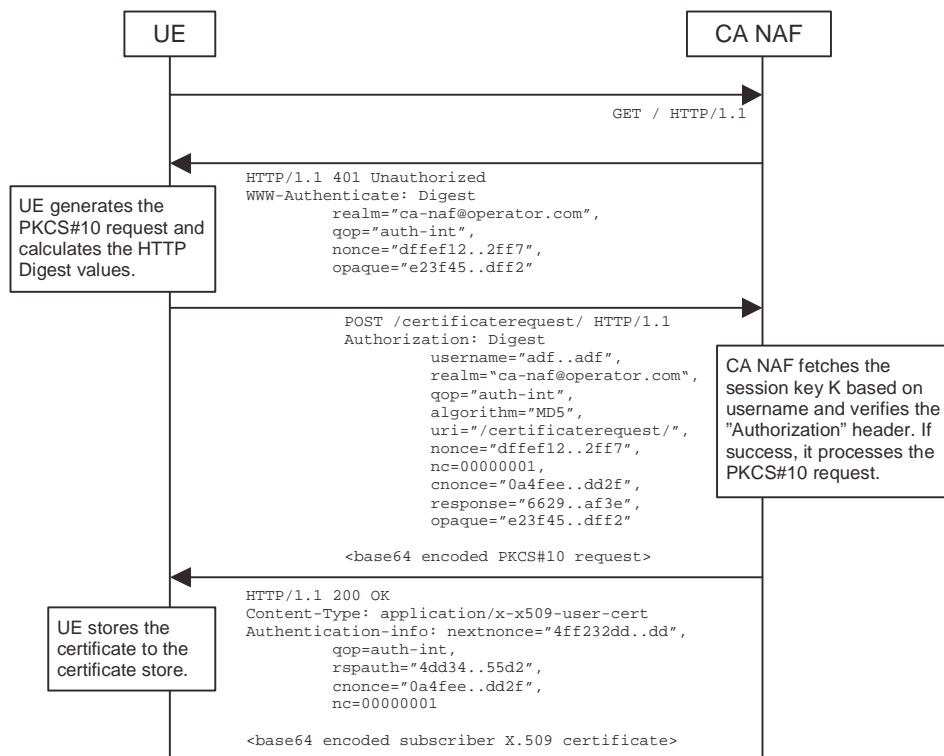

Figure 2: Certificate request using PKCS#10 with HTTP Digest Authentication.

The sequence diagram above describes the certificate request when using PKCS#10 with HTTP Digest. The sequence starts with an empty HTTP request to CA NAF. The CA NAF responds with HTTP response code 401 “Unauthorized” which contains a WWW-Authenticate header. The header instructs the UE to use HTTP Digest authentication.

The UE generates a PKCS#10 request with the subject name, public key, additional attributes and extensions. Then it will generate the HTTP request by calculating the Authorization header values using the identifier it received from the BSF as username and the session key K.

When CA NAF receives the request, it will verify the Authorization header by fetching the session key K from the bootstrapping server using the identifier, then calculating the corresponding digest values using K, and finally comparing the calculated values with the received values in the Authorization header. If the verification succeeds, the incoming PKCS#10 request is taken in for further processing. If the CA NAF is actually a registration authority (RA NAF), the PKCS#10 request is forwarded to CA using any protocol available (e.g., CMC or CMP). After the PKCS#10 request has been processed and a certificate has been created, the new certificate is returned to the CA NAF. It will generate a HTTP response containing the certificate. The CA NAF may use session key K to integrity protect and authenticate the response.

When UE receives the subscriber certificate, it is stored to local certificate management system.

NOTE: On board key generation is already defined in the WIM specification [WIM] issued by Open Mobile Alliance (OMA) group."

4.4.1.2 Certificate issuing with CMP

CMP defines two methods to do the certificate issuing: basic authenticated scheme and centralized scheme. In the basic authenticated scheme the key generation happens in the UE while in the centralized scheme the key generation is done in the CA (or RA). CMP states that the support for the basic authenticated scheme for certificate issuing is mandatory for CAs while the support for the centralized scheme is optional. See more details in chapters 2.2 and B8 of [RFC2510].

The messages can be transported using various methods such as file based protocol, (such files can be used to transport PKI messages e.g. using FTP, HTTP, email etc.), direct TCP-based management protocol, management protocol via e-mail, and management protocol via HTTP mentioned in section 5 of [RFC2510].

4.4.1.2.1 Basic authenticated scheme

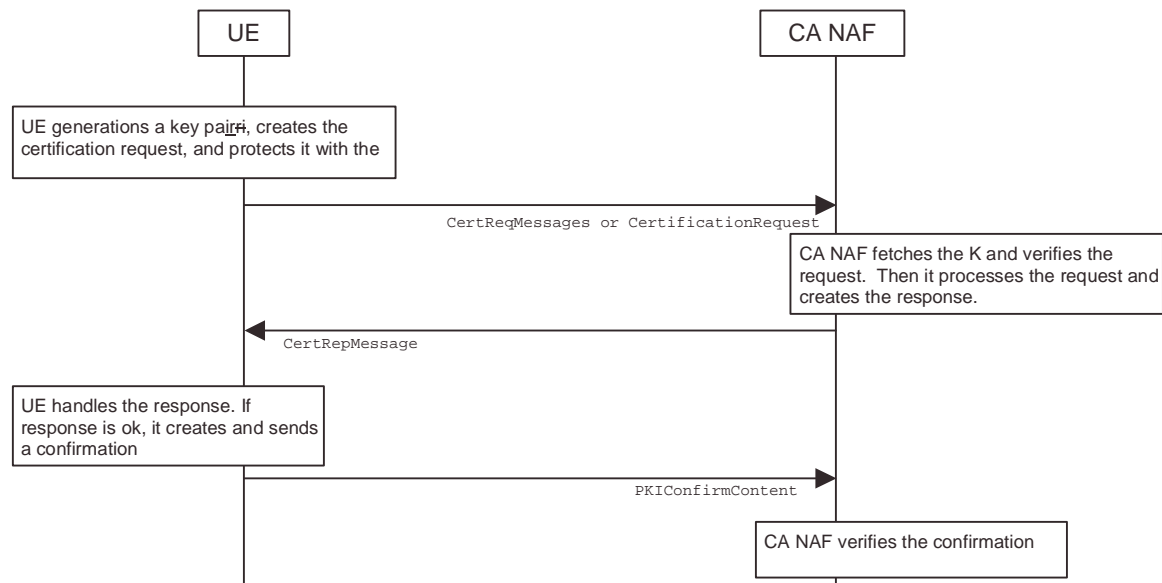

Figure 3: Certificate request using basic authentication scheme of CMP.

The sequence diagram above describes the certificate request and delivery procedure when using CMP and basic authenticated scheme [RFC2510]. The sequence starts with UE generating a key pair, creating the certificate request message format (CRMF) message, inserting it to CertReqMessages message, and integrity protecting this message with the initial authentication key (IAK). The session key K, which has been derived earlier using Ub interface, can be used as IAK.

The certificate request message is sent to CA NAF who fetches the corresponding K based on the identifier received in the request. CA NAF verifies the request with the K. If the verification succeeds, the CA NAF processes the request, i.e. generates and signs the certificate and sends the certification response to the UE.

UE verifies the certificate response message with the K. If the message verification is successful, the issued certificate is stored to the device, and UE sends a confirmation message to the CA NAF.

CA NAF verifies the confirmation message. If the verification fails or CA NAF never receives the confirmation message, CA NAF must revoke the newly issued certificate if it has been already published.

4.4.1.2.2 Centralized scheme initiated by the UE

The centralized scheme provides a mechanism where the public/private key pair is generated outside the UE, e.g. by the CA.

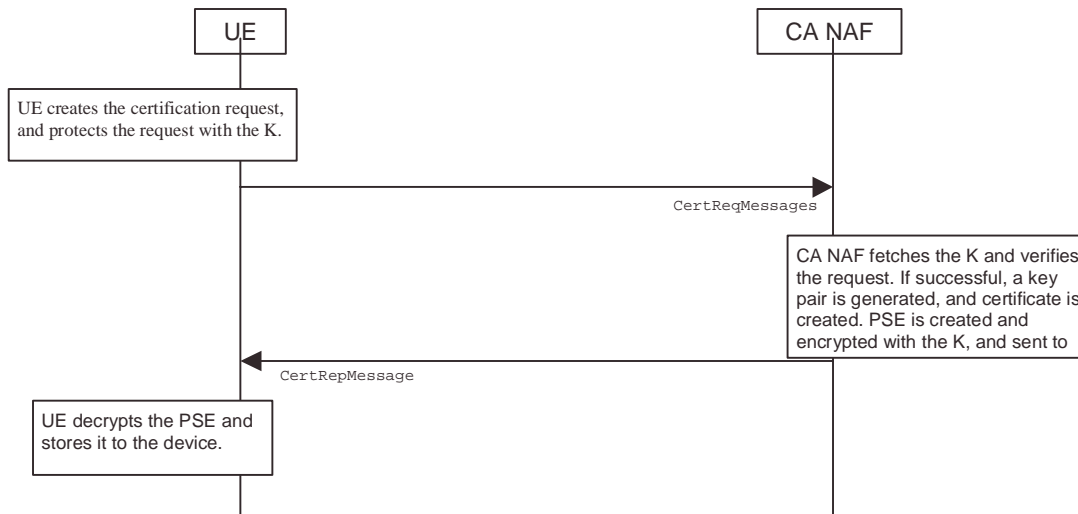

Figure 4: Certificate request using centralized scheme of CMP.

The sequence diagram above describes the delivery mechanism initiated by the UE using CMP in centralized scheme. This scheme is optional in CMP [RFC2510]. The sequence starts with the UE by creating CertReqMessages message with certain parameters, and protecting this message with initial authentication key (IAK). The session key K, which has been derived earlier using Ub interface, can be used as IAK.

The certificate request message is sent to CA NAF who fetches the corresponding K based on the identifier received in the request. CA NAF verifies the request with the K. If the verification succeeds, CA NAF processes the request, i.e. generates a key pair, generates and signs the certificate, and sends the certification response containing the Personal Security Environment (PSE) encrypted to the UE. PSE typically contains the generated private key and newly issued certificate with corresponding public key.

UE verifies the certificate response message with the K. If the message verification is successful, the issued PSE is decrypted and stored to the device. A confirmation message is not sent in the centralized scheme.

4.4.2 CA Certificate delivery

4.4.2.1 CA Certificate delivery with HTTP Digest Authentication

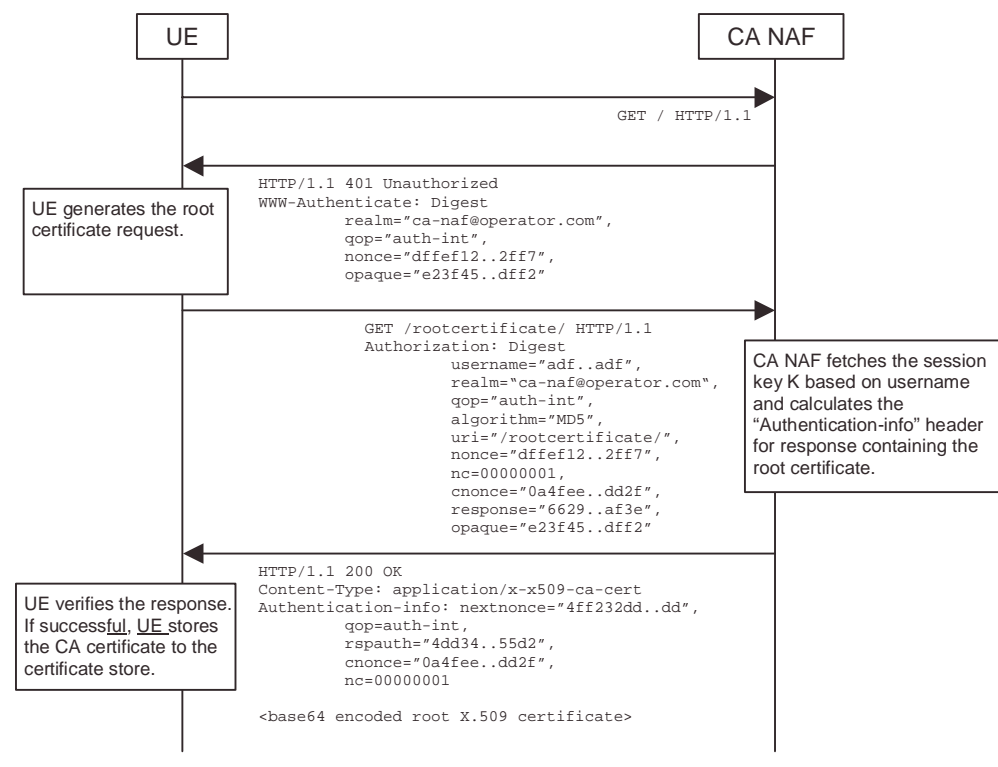

Figure 5: CA certificate delivery with HTTP Digest authentication.

The sequence diagram above describes the CA certificate delivery when using HTTP Digest authentication. The sequence starts with an empty HTTP request to CA NAF. The CA NAF responds with HTTP response code 401 "Unauthorized" which contains a WWW-Authenticate header. The header instructs the UE to use HTTP Digest for authentication.

The UE generates another empty HTTP request for requesting the CA certificate. The Authorization header values are calculated using the identifier and the session key K. The authentication of this HTTP request is not necessary, but it is done in order to follow HTTP Digest authentication specification. Also, the identifier needs to be transported to the CA, i.e. the NAF. A request of subscriber's certificate is specified in section 4.4.1.1.

When CA NAF receives the request, it may verify the Authorization header by fetching the session key K from the bootstrapping server using the identifier. CA NAF will generate a HTTP response containing the CA certificate and use the session key K to authenticate and integrity protect the HTTP response using the Authentication-info header. Essentially, the response could also be other delivery protocol in HTTP format, e.g. PKCS#7 cryptographic message with content type signedData.

When UE receives the new CA certificate, it must validate the Authentication-info header. If validation succeeds, the user is notified that a new CA certificate is taken into use. If user accepts the new CA certificate, it is stored to the local certificate management system and marked as "trusted" CA certificate.

4.4.2.2 CA Certificate delivery with CMP

CMP defines only out-of-band method for delivering CA certificates. CA certificate may be delivered as part of the certificate request, where the response could contain certificates that may be useful to the recipient. It can contain the whole certificate chain (including the CA certificate). The root CA produces a "self-certificate" and also produces a fingerprint of its public key. End entities that acquire this fingerprint securely via some out-of-band means can then verify the CA's self-certificate and hence the other attributes contained therein.

4.5 Functionality in presence of pre-certified key pair

Editor's notes: Based on contribution S3-030037, it was agreed to add this part into the present document for ffs.

An alternative to securing certificate enrolment based on AKA and bootstrapping function is to secure certificate enrolment based on signatures made with pre-certified key in the UE. This alternative has been specified by Open Mobile Alliance (see section 7.3.4 of [WPKI]) and is thus out of scope of this specification. The functionality in presence of pre-certified key pair in the UE is explained below only briefly.

In this alternative solution, the UE equipped with a UICC, is previously issued with a pre-loaded, long lasting, public/private key pair from the home network. This phase would occur out of band, and would result in the UE possessing a long lasting key pair stored in the UICC for the purposes of certificate request authentication. Open Mobile Alliance (OMA) group offers standardized solutions by means of WPKI specification [WPKI] and WIM specification [WIM] for the storage and the use of long-lasting key pair. USIM and WIM are examples of applications on the UICC that can deal with the long-lasting keys.

The UE can issue a request for a certificate to the CA, signing the request with the long lasting private key. The certificate request itself could contain a newly generated public key that is to be certified by the CA. This assumes that the new key pair is generated in the UICC. Or it is also possible for the CA to generate the new key pair and send it (protected) to the UICC. Access control security for the pre-loaded long-lasting private key should be at least as good as for access control for USIM.

Two options can be envisaged. Though the public/private key pair is long lasting, the validity of the subscriber certificates issued to the UE could be short-lived. In this case the long lasting public/private key pair is used for PKI applications (e.g. in mobile-commerce) in combination with the short-lived certificates. Alternatively, the long lasting public/private key pair could come with a long-term certificate. The long-term private key would then have a restricted purpose, e.g. only to be used to authenticate subscriber certificate requests. The latter would be used to obtain another, short-lived certificate on a short-lived public/private key pair. It would then be the short-lived keys that could be used for e.g. m-commerce and other 3G PKI applications.

Annex ~~<A>~~ (informative): Support for subscriber certificates based on bootstrapping

A.1 ~~Introduction~~

This annex describes how operators issue the subscriber certificates and deliver operator CA certificates to subscribers.

A.2 ~~Additional requirements and principles~~

A.2.1 ~~Usage of Bootstrapping~~

Issuing procedures of the subscriber certificate and operator CA certificate shall be secured by using shared keys obtained from bootstrapping function.

A.2.2 ~~Access independence~~

Subscriber certificate and operator CA certificate issuing procedures are access independent. Certificate issuing procedures require IP connectivity from UE.

A.2.3 ~~Roaming and service network support~~

The roaming subscriber shall be able to request subscriber certificates and operator CA certificates from home network.

Editor's note: Certificate requests to any than home network may be supported in later phase of the present specification.

A.2.4 ~~Home operator control~~

Home operator shall be able to control the issuing of subscriber certificates. The control includes to whom the certificates are allowed to issue and the types of issued certificates.

Operator control is supported by information in the subscriber profile. For each type of subscriber certificate, i.e. for different keyUsage in WAP Certificate and CRL Profile, subscriber profile shall contain a flag that allows or disallows the issuing of that type of certificate to subscriber.

Editor's note: Currently two keyUsage values are envisioned: authentication and signing.

Delivery of operator CA certificates is always allowed.

Editor's note: For the first phase of standardisation, only the case is considered where bootstrapping server functionality and network application function are located in the same network as the HSS. Thus in the first phase the home network control does not require any communication between home and visited networks. In later phases, when also visited network may issue certificates, standardized way of transferring the control information from home network to visited network is needed.

A.2.5 ~~Charging principles~~

The operator shall be capable to charge issuing of subscriber certificates or delivery of operator CA certificates.

Editor's note: The charging mechanism and whether it needs to be standardized in 3GPP is FFS.

A.2.6—Subscriber Certificate Profile

Subscriber certificate profile shall be based on WAP Certificate and CRL Profile [WAPCert], which in turn is based on profiles defined in [RFC3280] and [X.509]. A certificate profile defines the format and semantics of certificates in a specific context. WAP Certificate and CRL profiles specification defines four certificate profiles: two user certificate profiles—one for authentication and the other for non repudiation purposes, server certificate profile for authentication, and authorization certificate profile (i.e., CA certificate). Since subscriber certificates are issued to users, and since services need CA certificate to validate subscriber certificates, the relevant WAP certificate profiles to be used with subscriber certificate profiles are the user certificate profiles, and CA certificate profile.

Editor's note: Applicability of other certificate profile specifications, e.g. RFC 3281, ETSI QC profile is FFS.

The following certificate extensions shall be filled with the information given by the UE in the certification request:

- Intended certificate usage (i.e., using keyUsage and/or extKeyUsage extensions [WAPCert]).
- Subscriber identities (i.e., subject name field, and possible additional identities defined in the subjectAltName extension [WAPCert]). Operator CA shall authorize each suggested subscriber identity.
- Proof of key origin (i.e., keyGenAssertion). Operator CA shall verify the proof of key origin if it is presented.

Note: It is not mandatory for Operator CA to insert these suggested extensions by UE to the certificate. Rather, Operator CA shall issue certificates based on its certification policies. It may write a certification practice statement (CPS) [RFC2527], where it describes the general requirements and steps taken during the certificate issuing.

A.2.7—Service Discovery

The addresses of bootstrapping server and PKI portal may be pre-configured to the UE or UICC. The possible service discovery or over-the-air configuration mechanism are FFS.

Editor's note: For the first phase of standardisation, when bootstrapping server functionality and network application function are always located in home network, therefore pre-configuration of addresses is sufficient. In later phases, however, when UE needs to address of PKI Portal in the visited network, more flexible is needed in the solution.

A.3—Certificate issuing architecture

A.3.1—Reference model

Figure 1 below shows a simple network model of the entities involved in the certificate issuing, and the protocols used between the network entities.

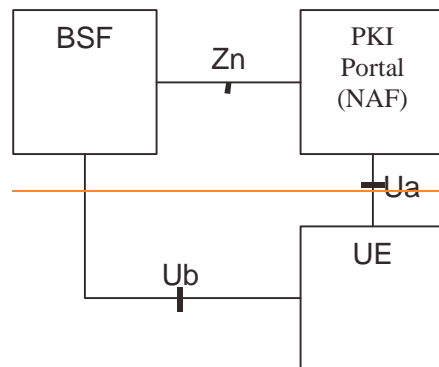

Figure 1: Simple network model for certificate issuing.

A.3.2 Network elements

A.3.2.1 PKI Portal

A PKI Portal shall issue a certificate for UE and deliver an operator CA certificate. In both cases, requests and responses are protected by shared key material that has been previously established between UE and a BSF.

In PKI terms, the PKI portal is a Registration Authority (RA) who authenticates the certification request based on cellular subscription (using interface Ub). PKI Portal may also function as a Certification Authority (CA) who will issue certificates. However, this task may also be done in an existing PKI infrastructure towards which the PKI Portal would function as a RA only, and the CA would be in the PKI infrastructure.

A.3.2.2 Bootstrapping Server Function

The bootstrapping server function (BSF) shall support the PKI portal by providing the authentication [TS GBA] and subscriber profile information (i.e., whether subscriber is able to enrol a certain type of subscriber certificate).

A.3.2.3 UE

The required new functionality from UE is the support of the Ua interface (i.e. certification enrolment protocol) that is protected using the shared keys established during bootstrapping function.

In addition UE may have the capability to generate public and private key pairs, store the private key part to a non-volatile memory (e.g., in UICC), and protect the usage of the private key part (e.g., with a PIN).

A.3.3 Reference points

A.3.3.1 Ua interface

A.3.3.1.1 General description

In the certificate issuing, Ua interface is used to for:

- The operator CA certifying subscriber's public keys in format of certificates, and
- The delivery of the Operator CA certificate to the UE.

During subscriber certificate issuing, UE may request a certification of a public key. The supported request formats shall include PKCS#10. It is used to encapsulate the public key and other attributes (i.e., subject name, intended key usage, etc.). The request is transported from the UE to the PKI Portal using Ua interface. Upon receiving the certification request, PKI portal will certify the public key according to its own certification practice policies and subscriber profile which is fetched through BSF from HSS. If PKI Portal decides to certify the public key, it will digitally sign it, and generate the corresponding certificate, which is returned from PKI Portal to the UE, using Ua interface.

During operator CA certificate delivery, the UE may request the PKI Portal to deliver operator CA's certificate. In the corresponding response, the PKI Portal will deliver the CA's certificate to the UE. Since the operator's CA certificate is typically a self-signed certificate and the validation of certificates signed by this CA is based on this particular CA certificate, it needs to be delivered over authenticated and secured channel.

Authentication, integrity protection, and possibly encryption of the Ua interface messages are based on the BSF generated shared secret.

A.3.3.1.2 Functionality and protocols

Editor's note: From five alternatives investigated in S3-030073 and S3-030036, only the following two have been agreed to add to the present document as potential solutions:

A.3.3.1.2.1 — PKCS#10 with HTTP Digest Authentication

HTTP Digest Authentication scheme [RFC2617] may be done with BSF shared key material the following way:

- UE makes a blank HTTP request to the NAF
- NAF returns a HTTP response with “WWW-Authenticate” header indicating that HTTP Digest Authentication is needed. Quality of protection (qop) attribute is set to “auth-int” meaning that the content in following HTTP requests and responses are integrity protected.
- UE calculates the correct response to the “WWW-Authenticate” header using the *identifier* (base64 encoded) as the username and the session key *K* (base64 encoded) as the password. The session key *K* is has been previously derived from the key material *Ks* that resulted from running *Ub* interface. HTTP Digest Authentication parameters are returned in the “Authorization” header of HTTP Response.
- NAF validates the “Authorization” header and upon successful validation, performs the requested task. In the corresponding HTTP response, NAF calculates the relevant values for “Authentication-Info” header, which is used to authenticate and integrity protect the NAF response.
- UE validates the “Authentication-Info” header and upon successful validation, accepts the payload in the HTTP response.

A PKCS#10 [PKCS10] based certification request is sent to the CA NAF using a HTTP POST request, which MUST be authenticated and integrity protected by HTTP Digest Authentication.

Certificate is delivered using the HTTP response, which MAY be authenticated and integrity protected by HTTP Digest Authentication. The content type of the HTTP response is either “application/x-x509-user-cert” or “application/vnd.wap.cert-response” as specified in [WPKI].

The UE requests a CA certificate delivery by sending a plain HTTP GET request with specific parameters in the request URI. The request MAY be authenticated and integrity protected by HTTP Digest Authentication.

CA certificate is delivered using the HTTP response, which MUST be authenticated and integrity protected by HTTP Digest Authentication. The content type of the HTTP response would be “application/x-x509-ca-cert”. Note that the user should always be notified when a new CA certificate is taken into use.

A.3.3.1.2.2 — Certificate Management Protocols (CMP)

Certificate Management Protocols (CMP) [RFC2510] describes a set of messages that can be used between different PKI components, e.g., between the CA and the end entity as well as between two CAs. The messages used in the specification have the following general message structure called PKIMessage. PKIMessage contains four fields: PKIHeader, PKIBody, optional PKIProtection, and optional certificate list. The PKIHeader contains information, which is common to many PKI messages. The PKIBody contains the message specific information. The PKIProtection, when used, contains bits that protect the PKI message. The certificate list can contain certificates that may be useful to the recipient. [RFC2510]

In CMP, authentication is achieved by the PKI issuing the end entity with a secret value (initial authentication key) and reference value (used to identify the transaction) via some out of band means. The initial authentication key can then be used to protect relevant PKI messages (see chapters 2.2.1.2. and 3.1.3 of [RFC2510] for details). Also a replay prevention mechanism is specified.

The supported certificate request formats are PKCS#10 [PKCS10] and CRMF [RFC-2511]. The certificate request is inserted in the PKIBody field of the PKIMessage. The response to the certificate request is a CertRespMessage that is inserted in the PKIBody field of the PKIMessage. The CertRespMessage contains the status of the response, and if certificate request was approved the certificate itself. CMP supports also a certification procedure where the key generation happens in the CA rather than in the UE. However, CMP states that this procedure is only optionally implemented by CAs. See more details in [RFC2510].

CMP defines data structures, which can support mechanism where the CA is able to publish its current public key using self-signed certificates that are distributed via some “out-of-band” means. Alternatively the self-signed CA certificate can be published on a directory server and a hash of the certificate can be distributed via some out-of-band means. The idea is that anyone who has securely received a hash value can verify the authenticity of the CA certificate. The structure of such a self-signed out-of-band certificate or hash is specified in the RFC. However, the way how the CA

publishes the self signed certificate and/or securely delivers the hash value is considered out of scope for CMP (see chapter 3.2.5 of [RFC2510]).

A.4 Certificate issuing procedure

A.4.1 Certificate issuing

Editor's note: From five alternatives investigated in S3-030073 and S3-030036, only the following two have been agreed to add to the present document as potential solutions.

A.4.1.1 Certificate issuing using PKCS#10 with HTTP Digest Authentication

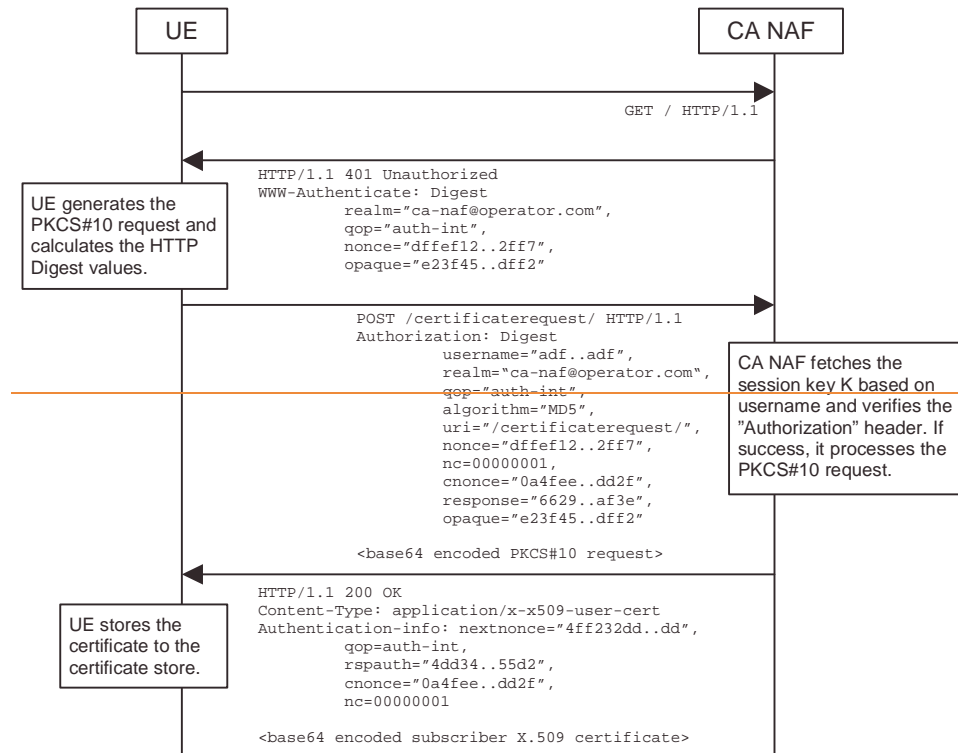

Figure 2: Certificate request using PKCS#10 with HTTP Digest Authentication.

The sequence diagram above describes the certificate request when using PKCS#10 with HTTP Digest. The sequence starts with an empty HTTP request to CA NAF. The CA NAF responds with HTTP response code 401 “Unauthorized” which contains a WWW-Authenticate header. The header instructs the UE to use HTTP Digest authentication.

The UE generates a PKCS#10 request with the subject name, public key, additional attributes and extensions. Then it will generate the HTTP request by calculating the Authorization header values using the identifier it received from the BSF as username and the session key K .

When CA NAF receives the request, it will verify the Authorization header by fetching the session key K from the bootstrapping server using the identifier, then calculating the corresponding digest values using K , and finally comparing the calculated values with the received values in the Authorization header. If the verification succeeds, the incoming PKCS#10 request is taken in for further processing. If the CA NAF is actually a registration authority (RA NAF), the PKCS#10 request is forwarded to CA using any protocol available (e.g., CMC or CMP). After the PKCS#10 request has been processed and a certificate has been created, the new certificate is returned to the CA NAF. It will generate a HTTP response containing the certificate. The CA NAF may use session key K to integrity protect and authenticate the response.

When UE receives the subscriber certificate, it is stored to local certificate management system.

NOTE: On-board key generation is already defined in the WIM specification [WIM] issued by Open Mobile Alliance (OMA) group."

A.4.1.2 Certificate issuing with CMP

CMP defines two methods to do the certificate issuing: basic authenticated scheme and centralized scheme. In the basic authenticated scheme the key generation happens in the UE while in the centralized scheme the key generation is done in the CA (or RA). CMP states that the support for the basic authenticated scheme for certificate issuing is mandatory for CAs while the support for the centralized scheme is optional. See more details in chapters 2.2 and B8 of [RFC2510].

The messages can be transported using various methods such as file based protocol, (such files can be used to transport PKI messages e.g. using FTP, HTTP, email etc.), direct TCP-based management protocol, management protocol via e-mail, and management protocol via HTTP mentioned in section 5 of [RFC2510].

A.4.1.2.1 Basic authenticated scheme

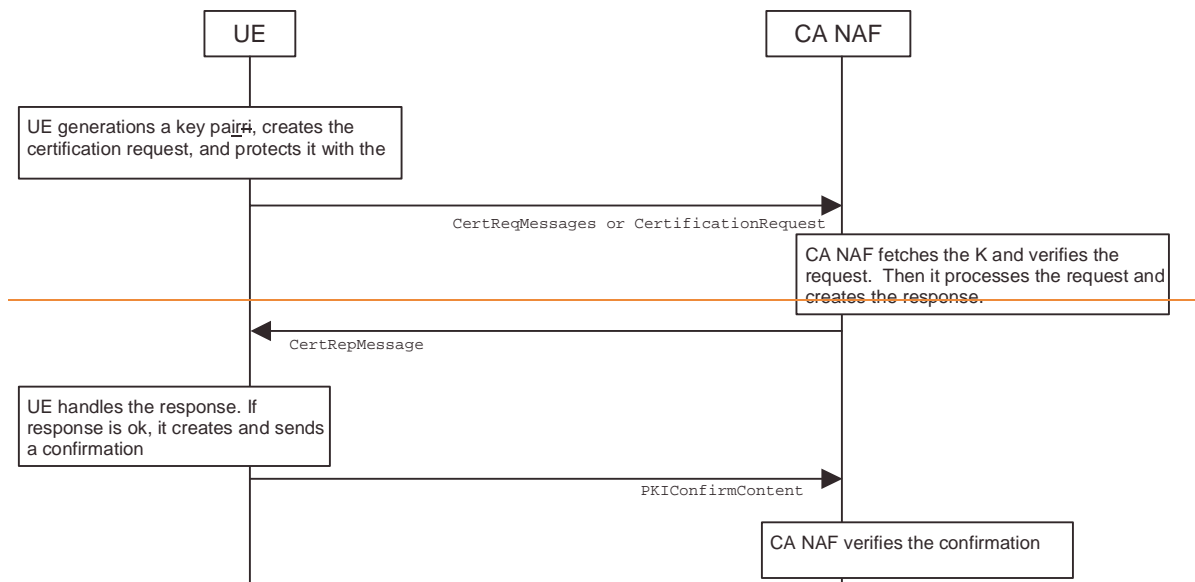

Figure 3: Certificate request using basic authentication scheme of CMP.

The sequence diagram above describes the certificate request and delivery procedure when using CMP and basic authenticated scheme [RFC2510]. The sequence starts with UE generating a key pair, creating the certificate request message format (CRMP) message, inserting it to CertReqMessages message, and integrity protecting this message with the initial authentication key (IAK). The session key K, which has been derived earlier using Ub interface, can be used as IAK.

The certificate request message is sent to CA NAF who fetches the corresponding K based on the identifier received in the request. CA NAF verifies the request with the K. If the verification succeeds, the CA NAF processes the request, i.e. generates and signs the certificate and sends the certification response to the UE.

UE verifies the certificate response message with the K. If the message verification is successful, the issued certificate is stored to the device, and UE sends a confirmation message to the CA NAF.

CA NAF verifies the confirmation message. If the verification fails or CA NAF never receives the confirmation message, CA NAF must revoke the newly issued certificate if it has been already published.

A.4.1.2.2 Centralized scheme initiated by the UE

The centralized scheme provides a mechanism where the public/private key pair is generated outside the UE, e.g. by the CA.

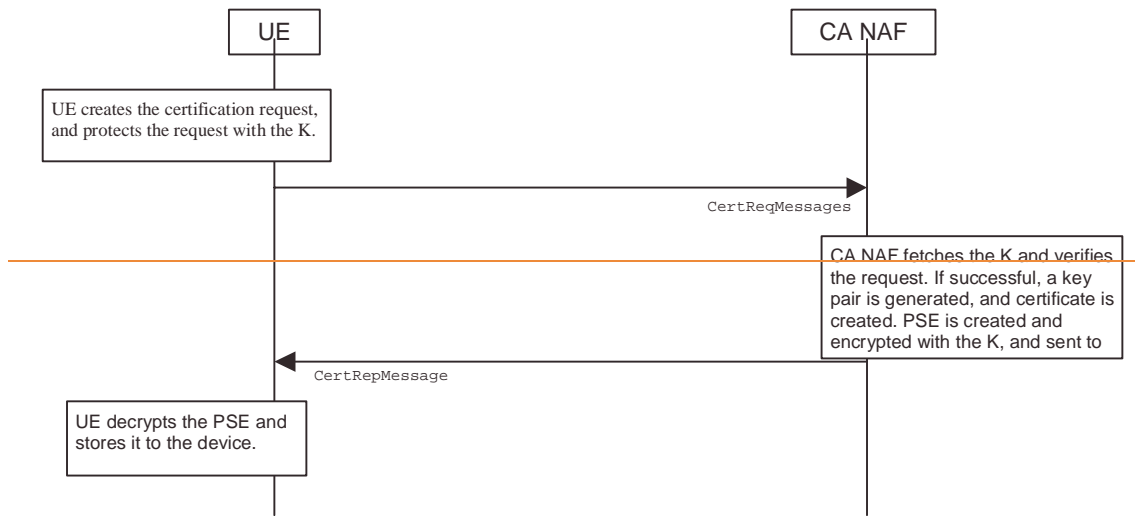

Figure 4: Certificate request using centralized scheme of CMP.

The sequence diagram above describes the delivery mechanism initiated by the UE using CMP in centralized scheme. This scheme is optional in CMP [RFC2510]. The sequence starts with the UE by creating CertReqMessages message with certain parameters, and protecting this message with initial authentication key (IAK). The session key K, which has been derived earlier using Ub interface, can be used as IAK.

The certificate request message is sent to CA NAF who fetches the corresponding K based on the identifier received in the request. CA NAF verifies the request with the K. If the verification succeeds, CA NAF processes the request, i.e. generates a key pair, generates and signs the certificate, and sends the certification response containing the Personal Security Environment (PSE) encrypted to the UE. PSE typically contains the generated private key and newly issued certificate with corresponding public key.

UE verifies the certificate response message with the K. If the message verification is successful, the issued PSE is decrypted and stored to the device. A confirmation message is not sent in the centralized scheme.

A.4.2 CA Certificate delivery

A.4.2.1 CA Certificate delivery with HTTP Digest Authentication

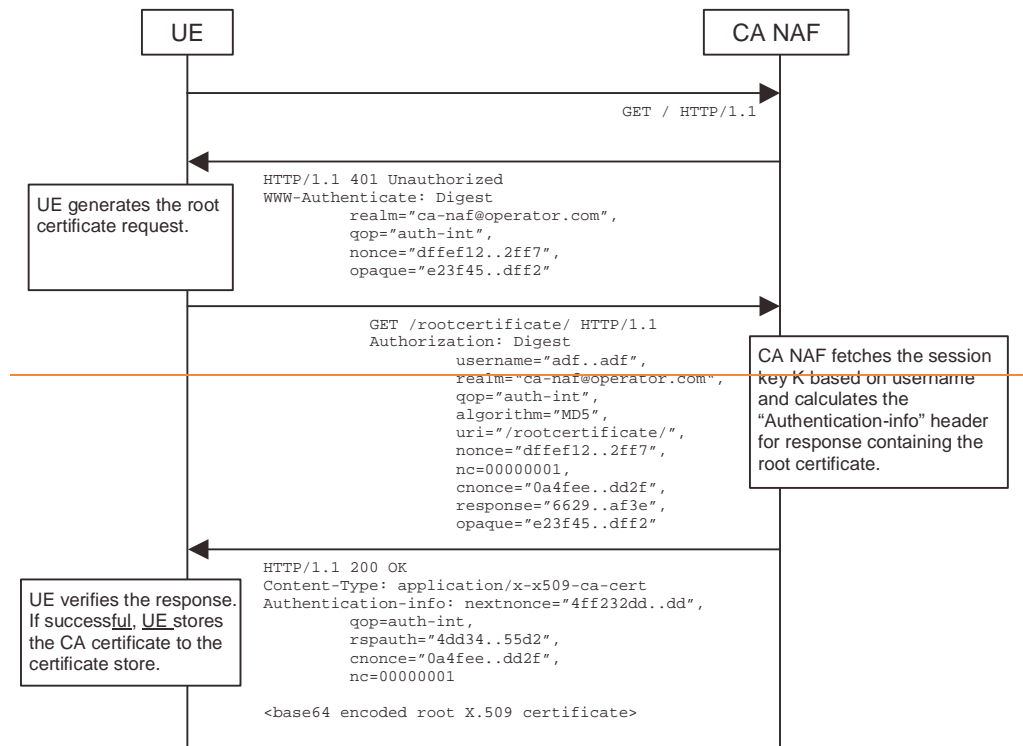

Figure 5: CA certificate delivery with HTTP Digest authentication.

The sequence diagram above describes the CA certificate delivery when using HTTP Digest authentication. The sequence starts with an empty HTTP request to CA NAF. The CA NAF responds with HTTP response code 401 “Unauthorized” which contains a WWW-Authenticate header. The header instructs the UE to use HTTP Digest for authentication.

The UE generates another empty HTTP request for requesting the CA certificate. The Authorization header values are calculated using the identifier and the session key K . The authentication of this HTTP request is not necessary, but it is done in order to follow HTTP Digest authentication specification. Also, the identifier needs to be transported to the CA, i.e. the NAF. A request of subscriber’s certificate is specified in section A.4.1.1.

When CA NAF receives the request, it may verify the Authorization header by fetching the session key K from the bootstrapping server using the identifier. CA NAF will generate a HTTP response containing the CA certificate and use the session key K to authenticate and integrity protect the HTTP response using the Authentication-info header. Essentially, the response could also be other delivery protocol in HTTP format, e.g. PKCS#7 cryptographic message with content type signedData.

When UE receives the new CA certificate, it must validate the Authentication-info header. If validation succeeds, the user is notified that a new CA certificate is taken into use. If user accepts the new CA certificate, it is stored to the local certificate management system and marked as “trusted” CA certificate.

A.4.2.2 CA Certificate delivery with CMP

CMP defines only out-of-band method for delivering CA certificates. CA certificate may be delivered as part of the certificate request, where the response could contain certificates that may be useful to the recipient. It can contain the whole certificate chain (including the CA certificate). The root CA produces a “self-certificate” and also produces a fingerprint of its public key. End entities that acquire this fingerprint securely via some out-of-band means can then verify the CA’s self-certificate and hence the other attributes contained therein.

A.5 ~~Functionality in presence of pre-certified key pair~~

~~Editor's notes: Based on contribution S3-030037, it was agreed to add this part into the present document for ffs.~~

~~An alternative to securing certificate enrolment based on AKA and bootstrapping function is to secure certificate enrolment based on signatures made with pre-certified key in the UE. This alternative has been specified by Open Mobile Alliance (see section 7.3.4 of [WPKI]) and is thus out of scope of this specification. The functionality in presence of pre-certified key pair in the UE is explained below only briefly.~~

~~In this alternative solution, the UE equipped with a UICC, is previously issued with a pre-loaded, long-lasting, public/private key pair from the home network. This phase would occur out of band, and would result in the UE possessing a long-lasting key pair stored in the UICC for the purposes of certificate request authentication. Open Mobile Alliance (OMA) group offers standardized solutions by means of WPKI specification [WPKI] and WIM specification [WIM] for the storage and the use of long-lasting key pair. USIM and WIM are examples of applications on the UICC that can deal with the long-lasting keys.~~

~~The UE can issue a request for a certificate to the CA, signing the request with the long-lasting private key. The certificate request itself could contain a newly generated public key that is to be certified by the CA. This assumes that the new key pair is generated in the UICC. Or it is also possible for the CA to generate the new key pair and send it (protected) to the UICC. Access control security for the pre-loaded long-lasting private key should be at least as good as for access control for USIM.~~

~~Two options can be envisaged. Though the public/private key pair is long-lasting, the validity of the subscriber certificates issued to the UE could be short-lived. In this case the long-lasting public/private key pair is used for PKI applications (e.g. in mobile-commerce) in combination with the short-lived certificates. Alternatively, the long-lasting public/private key pair could come with a long-term certificate. The long-term private key would then have a restricted purpose, e.g. only to be used to authenticate subscriber certificate requests. The latter would be used to obtain another, short-lived certificate on a short-lived public/private key pair. It would then be the short-lived keys that could be used for e.g. m-commerce and other 3G PKI applications.~~

Annex <X> (informative): Change history

It is usual to include an annex (usually the final annex of the document) for specifications under TSG change control which details the change history of the specification using a table as follows:

Change history							
Date	TSG #	TSG Doc.	CR	Rev	Subject/Comment	Old	New
2003-10	SA3#30				<i>First draft TS: Support for Subscriber Certificates (SSC). Extracted from 33.109 sections 5 and Annex A.</i>		0.1.0
2003-10	SA3#30	S3-020536			<i>Further clarification on WAP Certificate and CRL profile.</i>		0.1.0
2003-10	SA3#30	S3-030537			<i>New interface names</i>		0.1.0