

CR-Form-v3
<b>CHANGE REQUEST</b>
⌘ <b>33.107 CR xxx</b> ⌘ rev <b>-</b> ⌘ Current version: <b>3.11.0</b> ⌘

For **HELP** on using this form, see bottom of this page or look at the pop-up text over the ⌘ symbols.

**Proposed change affects:** ⌘ (U)SIM  ME/UE  Radio Access Network  Core Network

<b>Title:</b>	⌘ Update of TS 33.107 for Release 5		
<b>Source:</b>	⌘ SA WG3 LI		
<b>Work item code:</b>	⌘ Security	<b>Date:</b>	⌘ 24.01.2001
<b>Category:</b>	⌘ <b>B</b>	<b>Release:</b>	⌘ REL-5
	Use <u>one</u> of the following categories: <b>F</b> (essential correction) <b>A</b> (corresponds to a correction in an earlier release) <b>B</b> (Addition of feature), <b>C</b> (Functional modification of feature) <b>D</b> (Editorial modification) Detailed explanations of the above categories can be found in 3GPP TR 21.900.		Use <u>one</u> of the following releases: 2 (GSM Phase 2) R96 (Release 1996) R97 (Release 1997) R98 (Release 1998) R99 (Release 1999) REL-4 (Release 4) REL-5 (Release 5)

<b>Reason for change:</b>	⌘ Inclusion of Release 5 interception requirements
<b>Summary of change:</b>	⌘
<b>Consequences if not approved:</b>	⌘

<b>Clauses affected:</b>	⌘		
<b>Other specs affected:</b>	<input type="checkbox"/> Other core specifications <input type="checkbox"/> Test specifications <input type="checkbox"/> O&M Specifications	⌘ 33.106 CR003	
<b>Other comments:</b>	⌘ CRs to previous Releases to be implemented before this CR		

**How to create CRs using this form:**

Comprehensive information and tips about how to create CRs can be found at: [http://www.3gpp.org/3G\\_Specs/CRs.htm](http://www.3gpp.org/3G_Specs/CRs.htm). Below is a brief summary:

- 1) Fill out the above form. The symbols above marked ⌘ contain pop-up help information about the field that they are closest to.
- 2) Obtain the latest version for the release of the specification to which the change is proposed. Use the MS Word "revision marks" feature (also known as "track changes") when making the changes. All 3GPP specifications can be downloaded from the 3GPP server under <ftp://www.3gpp.org/specs/>. For the latest version, look for the directory name with the latest date e.g. 2000-09 contains the specifications resulting from the September 2000 TSG meetings.
- 3) With "track changes" disabled, paste the entire CR form (use CTRL-A to select it) into the specification just in front of the clause containing the first piece of changed text. Delete those parts of the specification which are not relevant to the change request.

---

## Foreword

This Technical Specification has been produced by the 3GPP.

The contents of the present document are subject to continuing work within the TSG and may change following formal TSG approval. Should the TSG modify the contents of this TS, it will be re-released by the TSG with an identifying change of release date and an increase in version number as follows:

Version 3.y.z

where:

- 3 the first digit:
  - 3 Indicates TSG approved document under change control.
- y the second digit is incremented for all changes of substance, i.e. technical enhancements, corrections, updates, etc.
- z the third digit is incremented when editorial only changes have been incorporated in the specification.

---

## Introduction

This Technical Specification has been produced by the 3GPP TSG SA to allow for the standardisation in the area of lawful interception of telecommunications. This document describes in general the architecture and functions for lawful interception. Laws of individual nations and regional institutions (e.g. European Union), and sometimes licensing and operating conditions define a need to intercept telecommunications traffic and related information in modern telecommunications systems. It has to be noted that lawful interception shall always be done in accordance with the applicable national or regional laws and technical regulations.

---

# 1 Scope

The present document describes the architecture and functional requirements within a Third Generation Mobile Communication System (3GMS).

The specification shows the service requirements from a Law Enforcement point of view only. The aim of this document is to define a 3GMS interception system that supports a number of regional interception regulations, but these regulations are not repeated here as they vary. Regional interception requirements shall be met in using specific (regional) mediation functions allowing only required information to be transported.

---

# 2 References

- [1] ETR 331: "Definition of User Requirements for Lawful Interception of Telecommunications Requirements of the Law Enforcement Agencies".
- [2] ES 201 158: "Lawful Interception; Requirements for network functions".
- [3] ES 201 671: "Handover Interface for the lawful interception of telecommunications traffic".
- [4] GSM 01.33: "Lawful Interception requirements for GSM".
- [5] GSM 02.33: "Lawful Interception - stage 1".
- [6] GSM 03.33: "Lawful Interception - stage 2".
- [7] 3G TS 33.106: "3GPP Lawful Interception Requirements".
- [8] J-STD-25: "Interim Standard, Lawfully Authorised Electronic Surveillance".

---

# 3 Definitions, symbols and abbreviations

## 3.1 Definitions

For the purposes of the present document, the following terms and definitions apply.

**Network Based Interception:** Interception that is invoked at a network access point regardless of Target Identity.

**Subject Based Interception:** Interception that is invoked using a specific Target Identity

**Target Identity:** A technical identity that uniquely identifies a target of interception. One target may have one or several identities.

**Interception Area:** is a subset of the network service area comprised of a set of cells which defines a geographical zone.

**Location Dependent Interception:** is interception of a target mobile within a network service area that is restricted to one or several Interception Areas (IA).

## 3.2 Abbreviations

For the purposes of the present document, the following abbreviations apply:

3GMS	3rd Generation Mobile Communication System
3G GGSN	3rd Generation Gateway GPRS Support Node
3G GSN	3rd Generation GPRS Support Node (GGSN/SGSN)
3G MSC	3rd Generation Mobile Switching Center
3G SGSN	3rd Generation Serving GPRS Support Node
3G UMSC	3rd Generation Unified Mobile Switching Centre

ADMF	Administration Function
CC	Content of Communication
CGI	Cell Global Identity
DF	Delivery Function
ECT	Explicit Call Transfer
GPRS	General Packet Radio Service
HI	Handover Interface
IA	Interception Area
ICEs	<u>Intercepting Control Elements (3G MSC Server, 3G GMSC Server, P CSCF, S CSCF, SGSN, GGSN)</u>
IP	Internet Protocol
IRI	Intercept Related Information
LDI	Location Dependent Interception
LEA	Law Enforcement Agency
LEMF	Law Enforcement Monitoring Facility
INEs	<u>Intercepting Network Elements (such as SGSN, 3G MSC Server, 3G GMSC Server, MGW, P CSCF, S CSCF)</u>
RA	Routing Area

## 4 Functional architecture

The following figure contains the reference configuration for the lawful interception. The circuit switched configuration is shown in figure 1a. The packet switched configuration is shown in figure 1b. The various entities and interfaces are described in more detail in the succeeding subclauses.

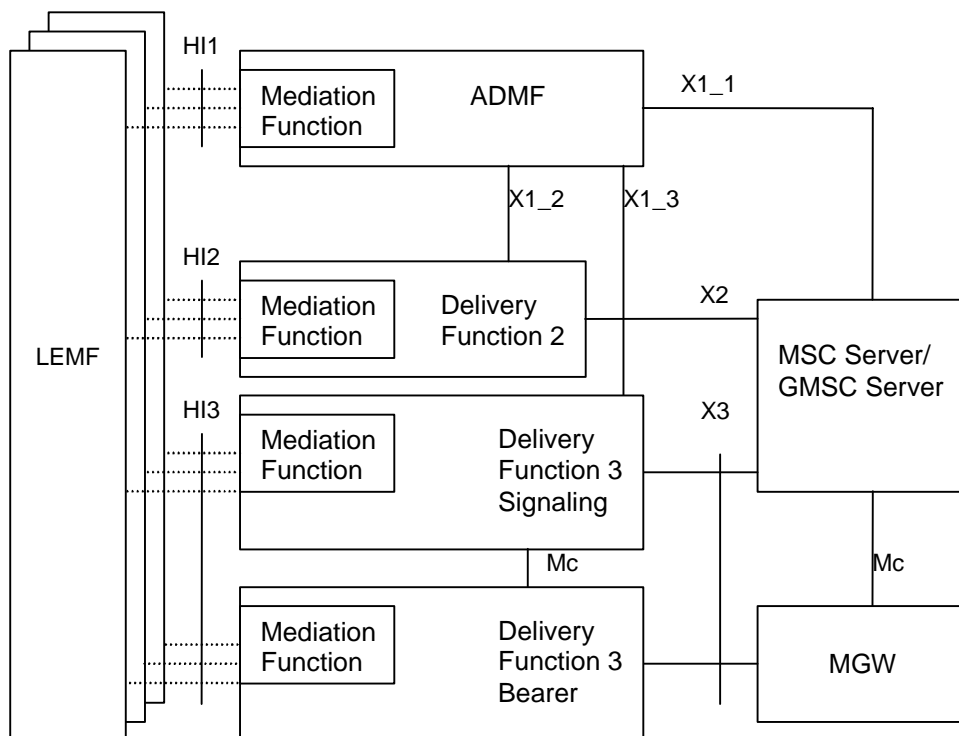

**Figure 1.a Circuit switched intercept configuration**

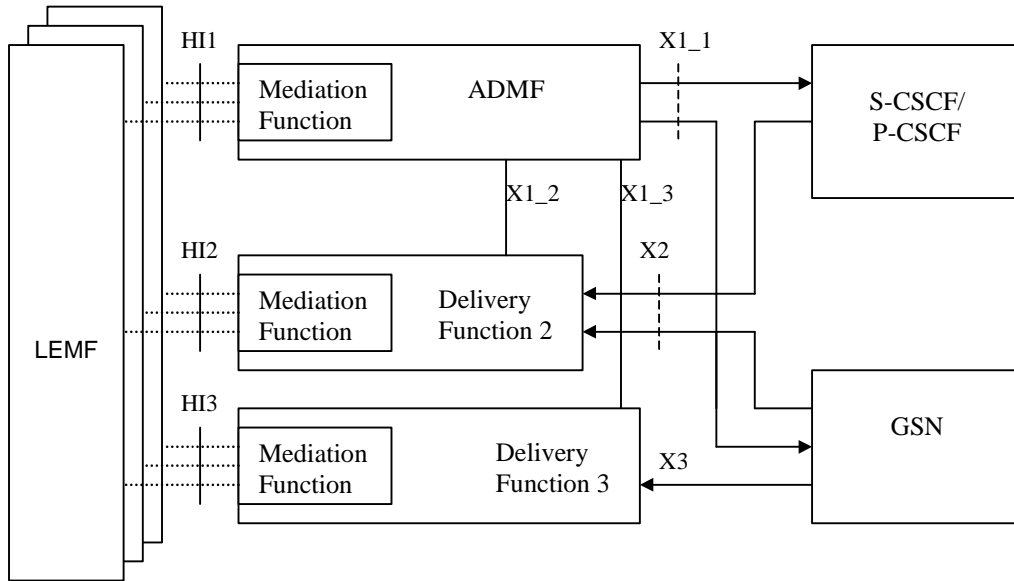

**Figure 1b Packet Switched Intercept configuration**

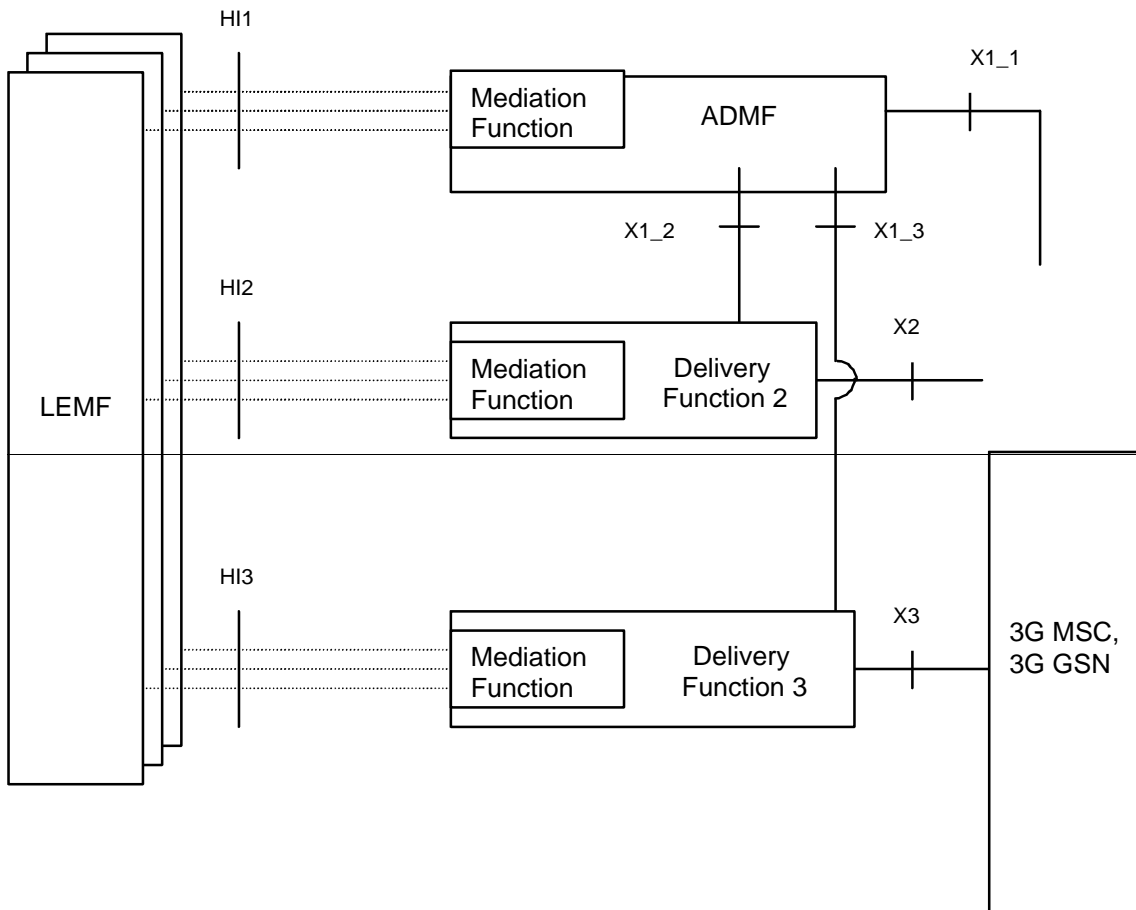

**Figure 1: Reference configuration**

The reference configuration is only a logical representation of the entities involved in lawful interception and does not mandate separate physical entities. This allows for higher levels of integration.

Regional Mediation Functions, which may be transparent or part of the administration and delivery functions, are used to convert information on the HI1, HI2 and HI3 interfaces in the format described in various national or regional specifications. For example, if ES 201 671 or J-STD-25 is used, then the adaptation to HI1, HI2 and HI3 will be as defined in those specifications.

DF3 is responsible two primary functions:

- Call Control (Signaling) for the intercepted product and
- Bearer Transport for the intercepted product.

HI3 is the interface towards the LEMF. It must be able to handle the signalling and the bearer transport for the intercepted product. LEMF can be located within the 3G network or can be in any other network.

There is one Administration Function (ADMF) in the network. Together with the delivery functions it is used to hide from the ~~3G MSC and 3G GSN~~3G INEs that there might be multiple activations by different Law Enforcement Agencies (LEAs) on the same target. The administration function may be partitioned to ensure separation of the provisioning data from different agencies.

The HI2 and HI3-interfaces represent the interfaces between the LEA and two delivery functions. The delivery functions are used:

- to distribute the Intercept Related Information (IRI) to the relevant LEA(s) via HI2 (based on IAs, if defined);
- to distribute the Content of Communication (CC) to the relevant LEA(s) via HI3 (based on IAs, if defined).

See the remaining sections of this document for definitions of the X1\_1, X1\_2, X1\_3, X2 and X3 interfaces.

Interception at the Gateways is a national option.

## 5 Activation, deactivation and interrogation

Figure 2 is an extraction from the reference intercept configuration shown in figure 1 which is relevant for activation, deactivation and interrogation of the lawful interception.

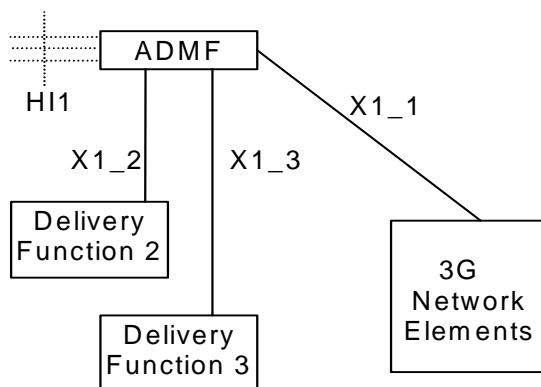

**Figure 2: Functional model for Lawful Interception activation, deactivation and interrogation**

In addition to the typical ~~3G MSC and 3G GSN~~3G INEs functional entities, a new functional entity is introduced - the ADMF - the Lawful Interception administration function. The ADMF:

- interfaces with all the LEAs that may require interception in the intercepting network;
- keeps the intercept activities of individual LEAs separate;
- interfaces to the intercepting network.

Every physical ~~3G MSC and 3G GSN~~3G ICE<sub>s</sub> is linked by its own X1\_1-interface to the ADMF. Consequently, every single ~~3G MSC and 3G GSN~~3G ICE performs interception (activation, deactivation, interrogation as well as invocation) independently from other ~~3G MSCs and 3G GSNs~~ICEs. The HI1-interface represents the interface between the requester of the lawful interception and the Lawful administration function; it is included for completeness, but is beyond the scope of standardisation in this document.

The target identities for 3GMS CS and GPRS interception at the SGSN, GGSN, 3G MSC Server and 3G GMSC Server can be at least one of the following: IMSI, MSISDN or IMEI.

The target identity for multi-media is the SIP URL at the CSCF. Other identities are for further study.

In case of location dependent interception the following network/national options exist:

- target location versus Interception Areas (IAs) check in the 3G MSC, 3G SGSN, 3G INEs and Delivery Functions (DFs);
- target location versus IAs check in the DFs (physical collocation of the DFs to the 3G MSC and 3G SGN 3G INEs, may be required by national law).

NOTE 1: The IA is previously defined by a set of cells. From the location of the target this set of cells permits to find the relevant IA.

NOTE 2: It is not required that the 3G GMSC or the 3G GGSN are used for interception when Location Dependent Interception is invoked and the location of the target is not available.

Editors note: location dependent intercept at the CSCF is for further study.

Editors note: location dependent intercept for the 3G MSC Server and SSGN is for further study

The ADMF shall be able to provision P-CSCFs independently from S-CSCFs on a network wide basis. All P-CSCFs, all S-CSCFs or both shall be administered for intercept as a network configuration. If both P-CSCFs and S-CSCFs are administered within the network for intercept, redundant multi-media IRI may be presented to the agency as a result.

## 5.1 Activation

Figures 3,4 and 5 show the information flow for the activation of Lawful Interception.

### 5.1.1 X1\_1-interface

The messages sent from the ADMF to the 3G MSC and 3G GSN 3G ICEs (X1\_1-interface) contain the:

- target identities (MSISDN, IMSI, ~~or~~ IMEI or SIP URL) (see note 4);
- information whether the Content of Communication (CC) shall be provided (see note 1);
- ~~— information whether the Intercept Related Information (IRI) shall be provided (see note 1);~~
- address of Delivery Function 2 (DF2) for the intercept related information (see note 2);
- address of Delivery Function 3 (DF3) for the intercepted content of communications (see note 3);
- IA in case of location dependent interception.

NOTE 1: As an option, the filtering whether intercept product and/or intercept related information has to be provided can be part of the delivery functions. (Note: intercept product options do not apply at the CSCF) If the option is used, the corresponding information can be omitted on the X1\_1-interface, while "information not present" means "intercept product and related information has to be provided" for the SN. Furthermore the delivery function which is not requested has to be "pseudo-activated", in order to prevent error cases at invocation.

NOTE 2: As an option, only a single DF2 is used by and known to every 3G MSC and 3G GSN 3G ICEs. In this case the address of DF2 can be omitted.

NOTE 3: As an option, only a single DF3 is used by and known to every 3G MSC and 3G GSN 3G ICEs. (except at the CSCFs) In this case the address of DF3 can be omitted.

NOTE 4: Since the IMEI is not available, interception of IMEI is not applicable at the 3G Gateway.

NOTE 5: Interception at the CSCFs is based only upon SIP URL. However, SIP URL as a target identity is not supported the other ICEs.

If after activation subsequently Content of Communications (CC) or Intercept Related Information (IRI) has to be activated (or deactivated) an "activation change request" with the same identity of the target is to be sent.

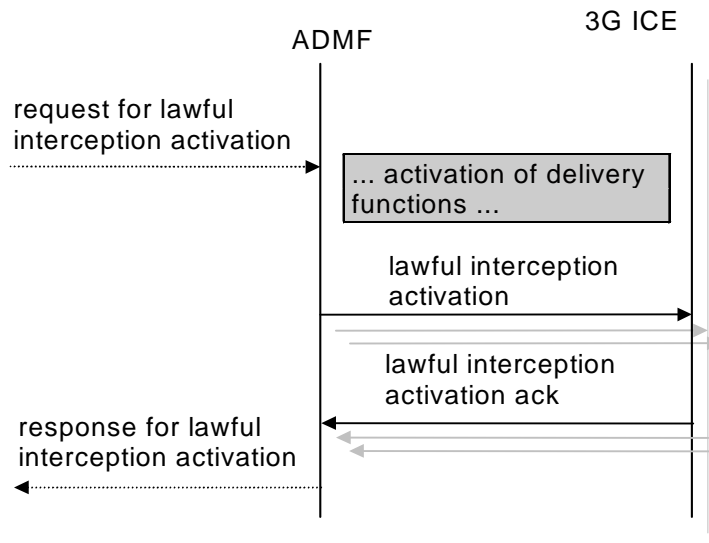

**Figure 3: Information flow on X1\_1-interface for Lawful Interception activation**

Interception of a target can be activated on request from different LEAs and each LEA may request interception via a different identity. In this case, each target identity on which to intercept will need to be sent via separate activation messages from ADMF to the 3G-MSC and 3G-GSN/3G-ICEs on the X1\_1-interface. Each activation can be for CC only, IRI only, or both CC and IRI.

When several LEAs request activation on the same identity then the ADMF determines that there are existing activations on the identity. In this case, the ADMF will not send an additional activation message to the 3G-MSC and 3G-GSN/3G-ICEs except when the activation needs to change from CC only or IRI only to CC and IRI. In that case an activation change message will be sent to the 3G-MSC and 3G-GSN/3G-ICEs.

### 5.1.2 X1\_2-interface (IRI)

For the activation of IRI the message sent from the ADMF to the DF contains:

- the target identity;
- the address for delivery of IRI (= LEMF address);
- which subset of information shall be delivered;
- a DF2 activation identity, which uniquely identifies the activation for DF2 and is used for further interrogation or deactivation, respectively;
- the IA in case of location dependent interception;
- the warrant reference number if required by national option.

If a target is intercepted for several LEAs and/or several identities simultaneously, a single activation of delivery is necessary for each combination of LEA and identity.



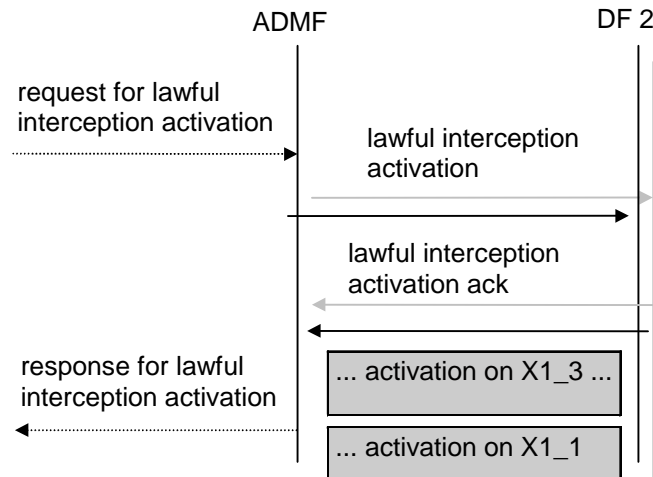

Figure 4: Information flow on X1\_2-interface for Lawful Interception activation

### 5.1.3 X1\_3-interface (CC)

For the activation of intercepted Content of Communications the message sent from the ADMF to the Delivery Function contains:

- the target identity;
- the address of delivery for CC (= LEMF address);
- a DF3 activation identity, which uniquely identifies the activation for DF3 and is used for further interrogation or deactivation, respectively;
- the IA in case of location dependent interception;
- the warrant reference number if required by national option.

If a target is intercepted by several LEAs and/or several identities simultaneously, a single activation of delivery is necessary for each combination of LEA and identity.

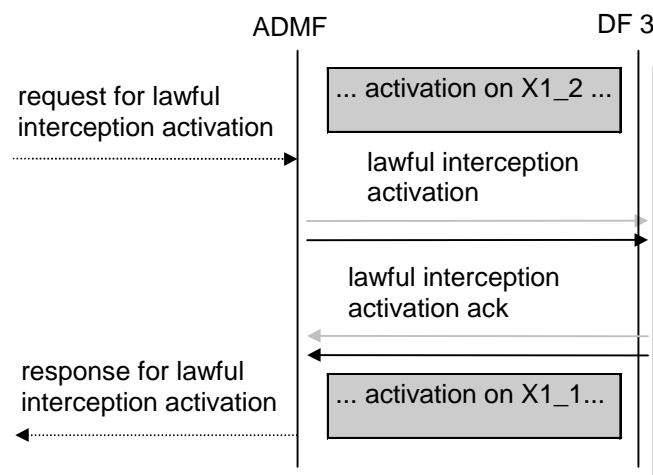

Figure 5: Information flow on X1\_3-interface for Lawful Interception activation

## 5.2 Deactivation

Figures 6,7 and 8 show the information flow for the deactivation of the Lawful interception.

### 5.2.1 X1\_1-interface

The messages sent from the ADMF to the ~~3G-MSC and 3G-GSN~~3G ICEs for deactivation contain:

- the target identity;
- the possible relevant IAs in case of location dependent interception.

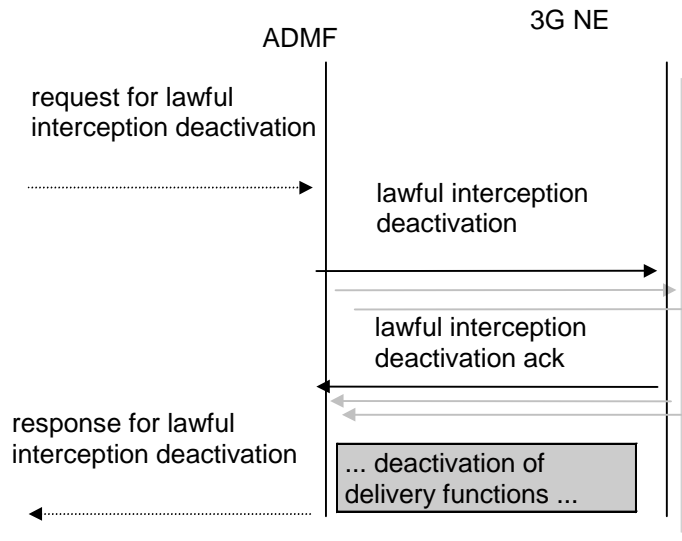

**Figure 6: Information flow on X1\_1-interface for Lawful Interception deactivation**

If interception of a target has been activated via different identities then a separate deactivation message will need to be sent from the ADMF to the ~~3G-MSC and 3G-GSN~~3G ICEs for each identity.

When several LEAs requested activation on the same identity and subsequently request deactivation then the ADMF determines that there are remaining activations on the identity. In this case, the ADMF will not send a deactivation message to the ~~3G-MSC and 3G-GSN~~3G ICEs except when the activation needs to change from CC and IRI to CC only or IRI only. In that case an activation change message will be sent to the ~~3G-MSC and 3G-GSN~~3G ICEs.

### 5.2.2 X1\_2-interface (IRI)

The messages sent from the ADMF to Delivery Function 2 for the deactivation of the Intercept Related Information contain:

- a DF2 activation id, which uniquely identifies the activation to be deactivated for DF2.

If a target is intercepted by several LEAs and/or several identities simultaneously, a single deactivation is necessary for each combination of LEA and identity.

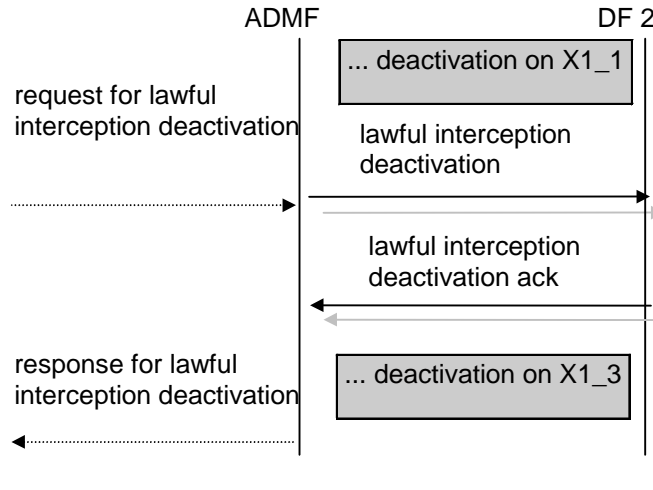

Figure 7: Information flow on X1\_2-interface for Lawful Interception deactivation

### 5.2.3 X1\_3-interface (CC)

For the deactivating the delivery of the CC the messages from the ADMF to DF3 contain:

- a DF3 activation id, which uniquely identifies the activation to be deactivated for DF3.

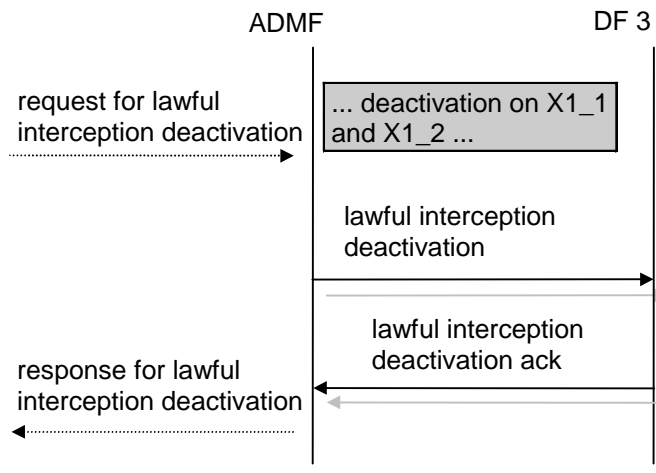

Figure 8: Information flow on X1\_3-interface for Lawful Interception deactivation

## 5.3 Interrogation

Interrogation provides the current status of the interception activation in the system. Interrogation of all activations for a given LEA is an ADMF function.

### 5.3.1 Interrogation of the 3G-MSC and 3G-GSN/3G-ICES

Figure 9 shows the information flow for the interrogation of the Lawful Interception. It shall be possible to interrogate

- a specific activation at each relevant 3G-MSC and 3G-GSN/3G-ICES;
- all activations at each relevant 3G-MSC and 3G-GSN/3G-ICES.

As result of the interrogation the activation status and data are returned.

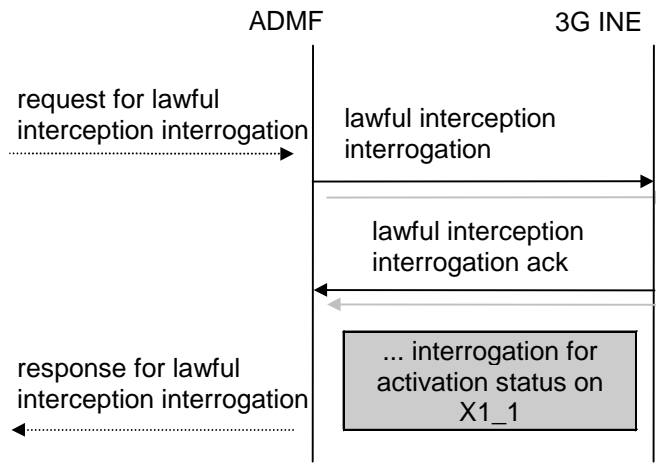

**Figure 9: Interrogation of the Lawful Interception (3G MSC and 3G GSN3G ICEs)**

### 5.3.2 Interrogation of Delivery Functions

Figure 10 shows the information flow for the interrogation of the Lawful Interception. It shall be possible to interrogate:

- a specific activation at a DF;
- all activations at a DF for a given target identity;
- all activations at a DF.

As result of the interrogation the activation status and data are returned.

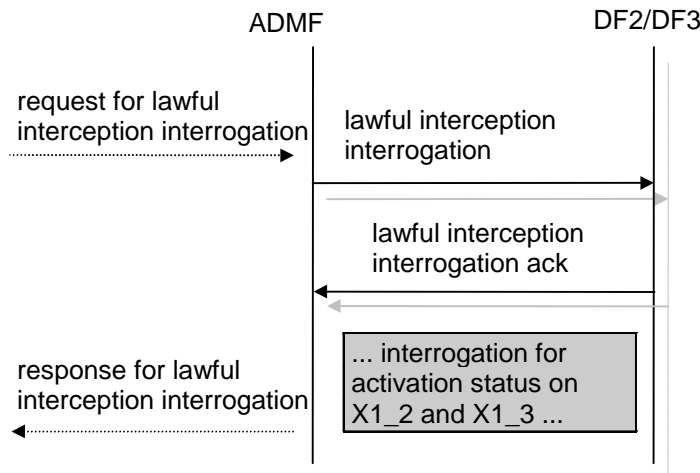

**Figure 10: Interrogation of the Lawful Interception (Delivery Functions)**

## 6 Invocation of Lawful Interception for Circuit Switched Services

Figure 11 shows an extraction from the reference configuration in figure 1 which is relevant for the invocation of the lawful interception.

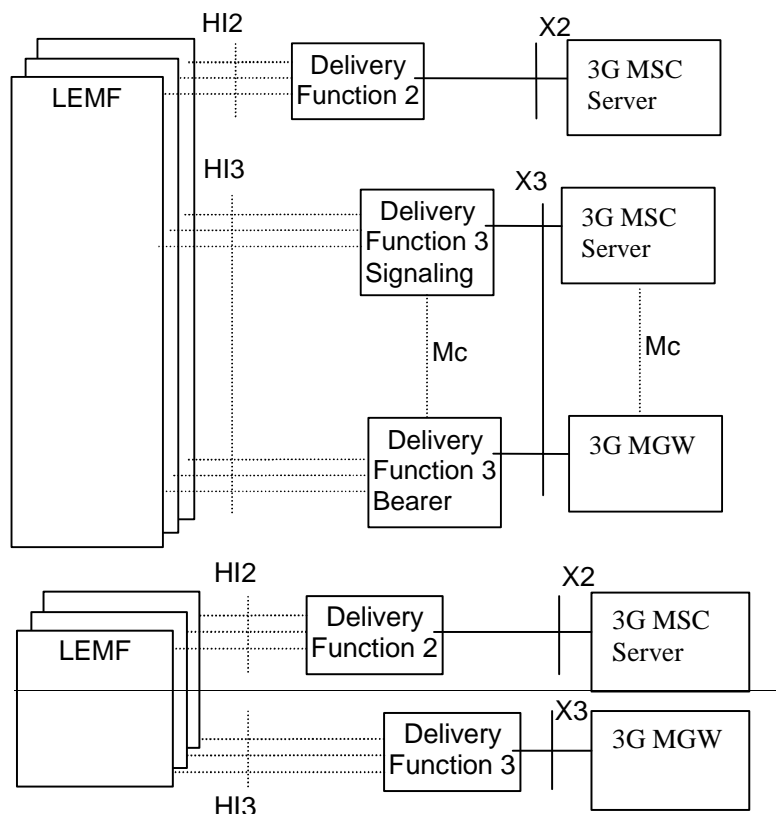

**Figure 11: Functional model for Lawful Interception invocation**

Editors note: update picture for new reference arch

The HI2 and HI3 interfaces represent the interfaces between the LEMF and two delivery functions. Both interfaces are subject to national requirements. They are included for ~~completeness~~completeness, but are beyond the scope of standardization in this document. The delivery functions are used:

- to convert the information on the X2-interface to the corresponding information on the HI2-interface;
- to convert the information on the X3-interface to the corresponding information on the HI3-interface;
- to distribute the intercept related information to the relevant LEA(s) (based on IAs, if defined);
- to distribute the intercept product to the relevant LEA(s) (based on IAs, if defined).

In case a call is selected based on several identities (MSISDN, IMSI, IMEI) of the same target, the 3G MSC will deliver CC and IRI only once to the DF2 and DF3. DF2 and DF3 will then distribute the information to the relevant LEA that requested interception on a particular target identity.

For the delivery of the CC and IRI, the 3G MSC Server provides a correlation number and target identity to the DF2 and DF3 which is used there in order to select the different LEAs to which the product shall be delivered.

NOTE: If interception has been activated for both parties of the call both CC and IRI will be delivered for each party as separate intercept activity.

The Mc interfaces between the 3G MSC Server and MGW, and between the DF3 signalling and DF3 bearer functions are used to establish the intercept and deliver the bearer to the agency.

For Location Dependent Interception, the location dependency check occurs at the establishment of each call. Subsequent dependency checks for simultaneous calls are not required, but can be a national option.

If a target is marked using an IA in the 3G MSC Server, the 3G MSC Server shall perform a location dependency check at call set-up. Only if the target's location matches the IA ~~thenis~~ the call is ~~the~~ intercepted.

If a target is marked using an IA in the DF2, the DF2 shall perform a location dependency check at reception of the first IRI for the call. Only if the target's location matches the IA for certain LEAs is IRI the relayed to these LEAs. All subsequent IRIs for the call are sent to the same LEAs.

If a target is marked using an IA in the DF3, the DF3 signalling function shall perform a location dependency check at reception of the CC. Only if the target's location matches the IA for certain LEAs is the CC relayed to these LEAs.

[Editors note: The use of the Mc interface for intercept is for further study. It is believed that intercept does not extend the Mc interface, but this needs to be identified. If an extension is needed, a paragraph description will be added here for the extension.]

## 6.1 Provision of Intercept CCProduct - Circuit Switched

Figure 12 shows the access method for the delivering of CC. The access method shall be a bridged/ T-connection, (see figure 12).

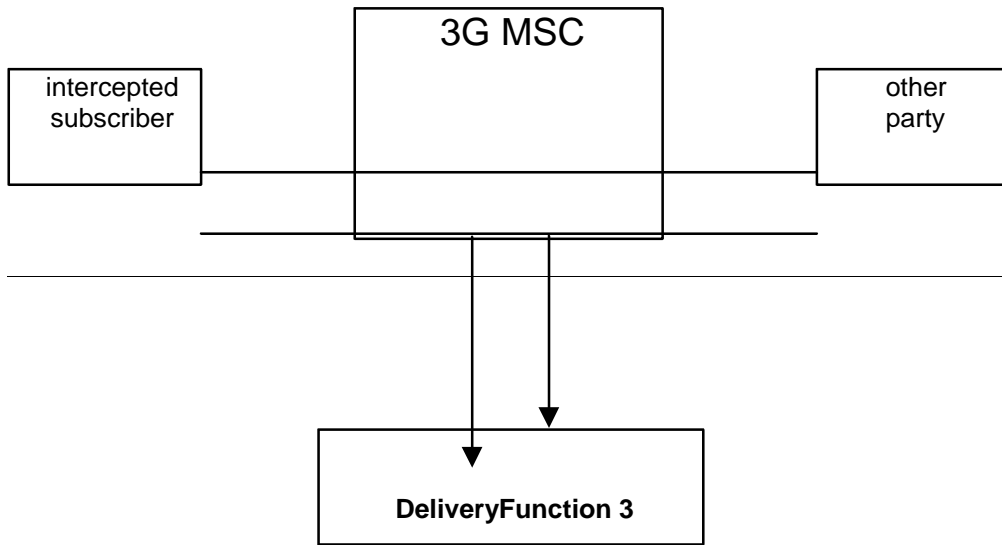

Figure 12: Bridged Access

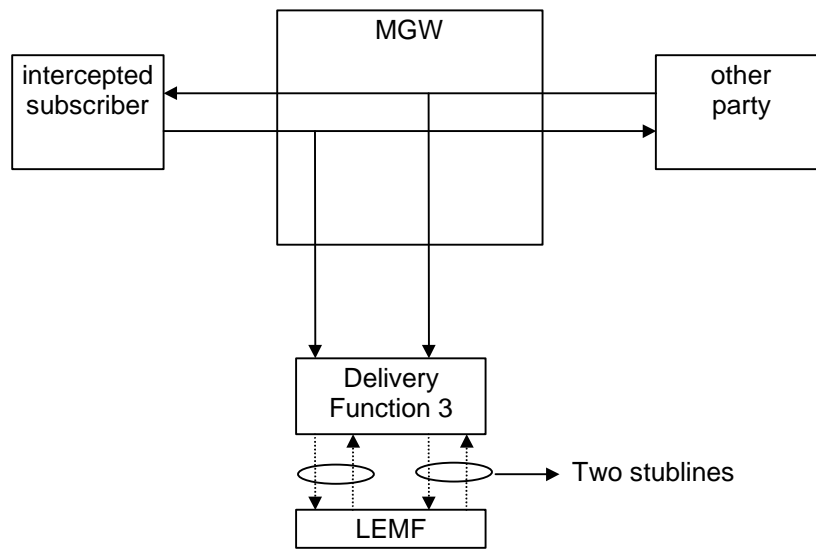

Figure 12: Delivery configuration to the LEMF for the interception of a circuit switched calls

### 6.1.1 Delivery configuration to the LEMF

Figure 13 shows the configuration for circuit switched calls. The signals of both parties of the configuration to be intercepted are delivered separately to the LEMF requesting function. The delivery requesting function itself has no impact on the connection between the subscribers.

The two stublines towards the LEMF are established in parallel to the call set up. For both stublines the address is used which has been provided during activation.

Bearer, and only bearer, is sent from the MGW to the bearer function of DF3.

NOTE: For data calls it is necessary to provide means for fast call establishment towards the LEMF to help ensure that LEMF so that it doesn't miss the beginning of the data transmission is delivered.

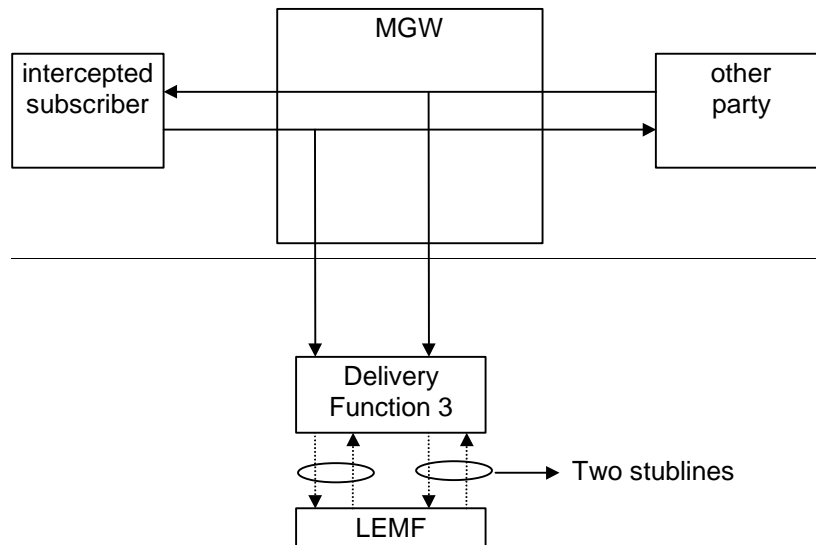

**Figure 13: Delivery configuration to the LEMF for the interception of a circuit switched call**

## 6.1.2 X3-interface

The following information needs to be transferred from the 3G MSC Server to the DF3 in order to allow the DF3 to perform its functionality:

- target identity (MSISDN, IMSI or IMEI); note 1
- signal indicator (Signal from target or signal to target)
- — the target location (if available) or the IAs in case of location dependent interception. note 1
- correlation number (IRI <-> CC);
- direction indication – (Signal from target or signal to target);

note 1: for DF3 internal use only

Additional information may be provided as national option.

## 6.2 Provision of CC - Short Message Service

Figure 14 shows an SMS transfer from the 3G MSC Server to the LEMF. Quasi-parallel to the delivery from / to the mobile subscriber a message, which contains the contents of the SMS with the header, is generated and sent via the Delivery Function 2 to the LEMF in the same way as the Intercept Related Information.

The IRI will be delivered to the LEMF:



- for a SMS-MO, when the SMS-Centre receives the SMS;
- for a SMS-MT, when the MS receives the SMS.

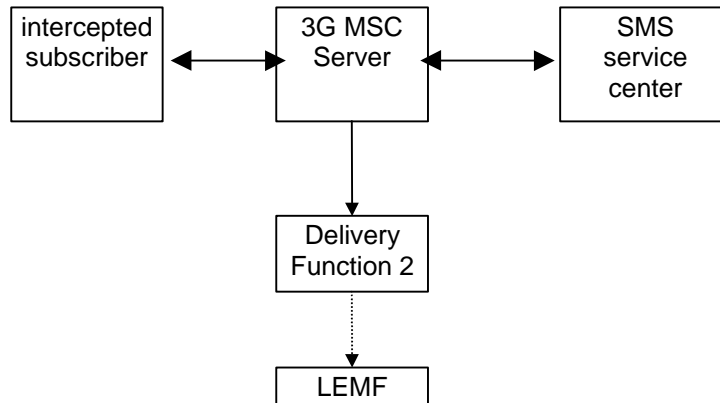

Figure 14: Provision of Content of Communication - Short Message Service

## 6.3 Provision of Intercept Related Information

Intercept Related Information (Events) are necessary at the Begin and End of the call, for all supplementary services during a call and for information which is not call associated. There are call related events and non call related events

Figure 15 shows the transfer of intercept related information to the DF2. If an event for / from a mobile subscriber occurs, the 3G MSC Server sends the relevant data to the DF2.

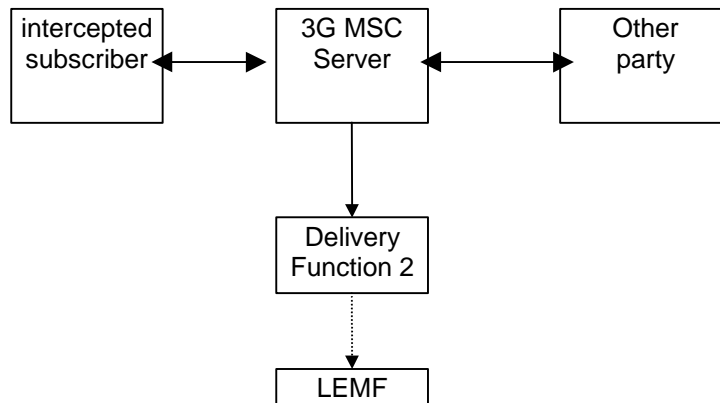

Figure 15: Provision of Intercept Related Information

### 6.3.1 X2-interface

The following information needs to be transferred from the 3G MSC Server to the DF2 in order to allow a DF2 to perform its functionality:

- target identity (MSISDN, IMSI or IMEI);
- in case of location dependent interception, the IAs and/or target cell ID shall be provided.
- events and associated parameters as defined in subclauses 6.3.3 and 6.3.4 may be provided.

## 6.3.2 Structure of the events

The information sent to DF2 is triggered by up to eight different call related and non-call related events. Details are described in following subclause. The events for interception are configurable (if they are sent to DF2) in the 3G MSC Server and can be suppressed in the DF2. The events are listed as follows:

Call Related Events:

- Call Establishment
- Answer
- Supplementary Service
- Handover
- Release

Non Call Related Events:

- SMS
- Location Update
- Subscriber Controlled Input

Table 1 below shows the set of information that is used to generate the events. The events transmit the information from the 3G MSC Server to DF2. This set of information can be extended in the 3G MSC Server, if this is necessary in a specific country. DF2 can extend this information if this is necessary in a specific country e.g. a unique number for each surveillance warrant.

**Table 1: Information Elements for Circuit Event records**

Observed MSISDN Target Identifier with the MSISDN of the target subscriber (monitored subscriber).
Observed IMSI Target Identifier with the IMSI of the target subscriber (monitored subscriber).
Observed IMEI Target Identifier with the IMEI of the target subscriber (monitored subscriber), It shall be checked for each call over the radio interface
event type Description which type of event is delivered: Establishment, Answer, Supplementary service, Handover, Release, SMS, Location update, Subscriber controlled input
event date Date of the event generation in the 3G MSC Server
event time Time of the event generation in the 3G MSC Server
dialled number Dialled phone number before digit modification, IN-modification etc.
Connected number Number of the answering party
other party address Directory number of the other party for MOC Calling party for MTC
call direction Information if the monitored subscriber is calling or called e.g. MOC/MTC or originating/ terminating In or/out
Correlation number Unique number for each call sent to the DF, to help the LEA, to have a correlation between each Call and the IRI
cell id <u>Network Element Identifier</u> <u>Unique identifier for the element reporting the ICE.</u> <del>Cell number of the target; for the location information</del>
Location Information <u>area code</u> <u>Location-area-code of the target defines the Location Area in a PLMN</u> <u>Location information is the service area identity and/or location area identity that is present at the 3G MSC Server at the time of event record production.</u>
basic service Information about Tele service or bearer service.
Supplementary service Supplementary services used by the target e.g. CF, CW, ECT
Forwarded to number Forwarded to number at CF
call release reason Call release reason of the target call
SMS Message The SMS content with header which is sent with the SMS-service
Redirecting number The number which invokes the call forwarding towards the target. This is provided if available.
SCI Non call related Subscriber Controlled Input (SCI) which the 3G MSC MSC Server receives from the ME

### 6.3.3 Call Related events

#### 6.3.3.1 Call establishment

For call establishment a call establishment-event is generated. This event is generated at the beginning of a call when the 3G MSC Server attempts to reach the subscriber. This information will be delivered to the DF2 if available:

Observed MSISDN
Observed IMSI
Observed IMEI
event type
event date
event time
dialled number
other party address
call direction
Correlation number
Redirecting number
<u>cell-id Network Element Identifier</u>
<u>Location area code</u> Information
basic service
Supplementary service

#### 6.3.3.2 Answer

If the called party answers, an answer- event is generated. This information will be delivered to the DF2 if available:

Observed MSISDN
Observed IMSI
Observed IMEI
event type
event date
event time
dialled number
other party address
Connected party
call direction
Correlation number
Redirecting number
<u>cell-id Network Element Identifier</u>
<u>Location area code</u> information
basic service
Supplementary service

### 6.3.3.3 Supplementary Services

For supplementary services events are generated with the information which supplementary service is used e.g. Call Forwarding (CF), Call Waiting (CW), Explicit Call Transfer (ECT), Multi Party (MPTY), Call Hold and information correlated to the service like the forwarded to number. This information will be delivered to the DF2 if available:

Observed MSISDN
Observed IMSI
Observed IMEI
event type
event date
event time
dialled number
other party address
call direction
Correlation number
<u>cell-id Network Element Identifier</u>
<u>Location area-code</u> information
basic service
Supplementary service
Forwarded to number

### 6.3.3.4 Handover

For each handover that is realised at the 3G MSC Server due to a target Cell ID change in target location information, a handover-event with the information about the new location information~~cell ID~~ is generated. This information will be delivered to the DF2 if available:

Observed MSISDN
Observed IMSI
Observed IMEI
event type
event date
event time
Correlation number
<u>cell-id Network Element Identifier</u>
<u>Location area-code</u> information

### 6.3.3.5 Release

For the release or failed attempt of a target call, a release event with the following information is generated. This information will be delivered to the DF2 if available:

Observed MSISDN
Observed IMSI
Observed IMEI
event type
event date
event time
dialled number
other party address
call direction
Correlation number
<u>cell-id Network Element Identifier</u>
<u>Location area-code</u> information
basic service
call release reason

## 6.3.4 Non Call Related events

### 6.3.4.1 SMS

For MO-SMS the event is generated in the 3G MSC Server, when the SMSC successfully receives the SMS; for MT-SMS the event is generated in the 3G MSC Server when the target receives the message. This information will be delivered to the DF2 if available:

Observed MSISDN
Observed IMSI
event type
event date
event time
<u>cell-id Network Element Identifier</u>
<u>Location area code information</u>
SMS Message

### 6.3.4.2 Location update

For location updates a Location update-event is generated, with the new location (~~location area~~)-information. This information will be delivered to the DF2 if available:

Observed MSISDN
observed IMSI
event type
event date
event time
<u>cell-id Network Element Identifier</u>
<u>location area code information</u>

### 6.3.4.3 Subscriber Controlled Input (SCI)

SCI includes subscriber initiated changes in service activation and deactivation. SCI does not include any information available in the CC. For subscriber controlled inputs - a SCI-event is generated with information about the SCI. This information will be delivered to the DF2 if available:

observed MSISDN
observed IMSI
event type
event date
event time
<u>cell-id Network Element Identifier</u>
<u>location area code location information</u>
SCI

## 6.4 Intercept cases for circuit switched supplementary services

### 6.4.1 Interception of Multiparty call

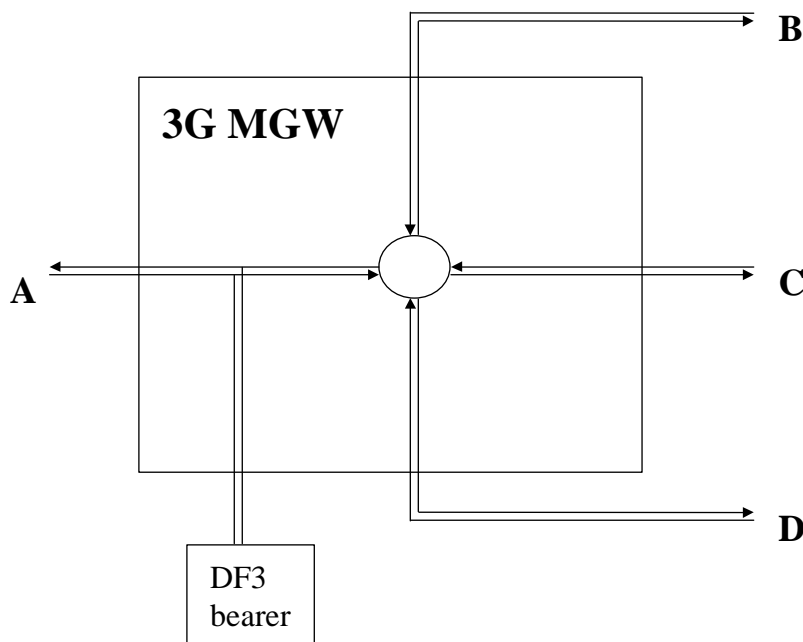
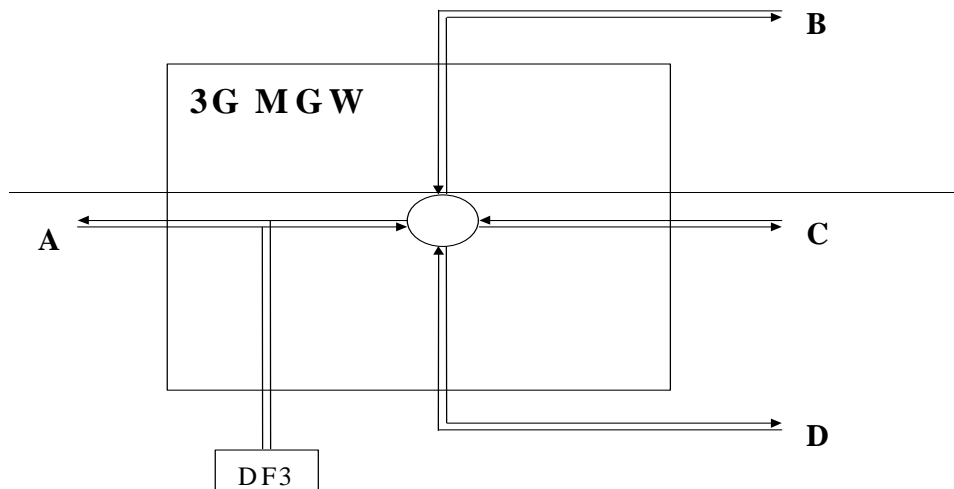

**Figure 16: Interception of Multiparty for CC**

Figure 16 shows the delivery of CC from intercepted multiparty call where party A is the target of interception.

One pair of call content channels are delivered to the delivery function. Party A is delivered to the DF3 on one channel and the sum of the balance of the parties, B,C and D is delivered on the second channel.

It should be noted that if parties B,C or D is a target of interception, that intercept is treated as a simple call intercept.

The events contain information about B, C and D if subscriber A is monitored. If one of B, C or D is monitored, events contain the information about A but not the other parties of the conference.

### 6.4.2 Interception for Call Forwarding / Call Deflection / ECT

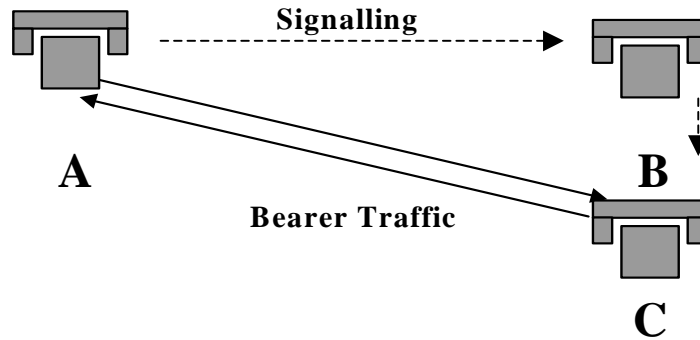

Figure 17: Interception for Call Forwarding / Deflection / ECT

The interception of party B once the supplementary service is invoked is a national option.

For Intercept Related Information it depends who is monitored:

- If subscriber A is monitored the number of A and B are mandatory in the event information and the number of C if available.
- If subscriber B is monitored the number of B and C are mandatory in the event information and the number of A if available.
- —If subscriber C is monitored the number of C is mandatory in the event information and the number of A and B if available.

Editor’s note: intercept requirements for CS multi-media is for further study

## 7 Invocation of Lawful Interception for GSN Packet Data services

Figure shows the extract from the reference configuration which is relevant for the invocation of the Lawful Interception of the packet data GSN network.

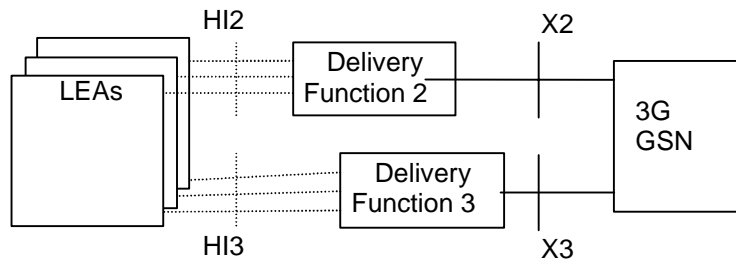

Figure 18: Functional model for Packet Data GSN Network Lawful Interception invocation

The HI2 and HI3 interfaces represent the interfaces between the LEA and two delivery functions. Both interfaces are subject to national requirements. They are included for completeness, but are beyond the scope of this specification. The delivery functions are used:



- to convert the information on the X2P-interface to the corresponding information on the H12 interface;
- to distribute the intercept related information to the relevant LEA(s);
- to distribute the intercept product to the relevant LEA(s).

In case a Packet Data communication is selected based on several identities (MSISDN, IMSI, IMEI, ) of the same target, the 3G SGSN and/or, per national option 3G GGSN will deliver CC and IRI only once to the DF2P and DF3P. DF2P and DF3P will then distribute the information to the relevant LEAs.

For the delivery of the CC and IRI the 3G SGSN and/or, per national option 3G GGSN provides correlation number and target identity to the DF2P and DF3P which is used there in order to select the different LEAs where the product shall be delivered.

The correlation number is unique in the whole PLMN and is used to correlate CC with IRI and the different IRI's of one PDP context.

The correlation number shall be generated by using existing parameters related to the PDP context.

NOTE: If interception has been activated for both parties of the Packet Data communication both CC and IRI will be delivered for each party as separate intercept activity.

In case of location dependent interception :

- for each target, the location dependency check occurs at each Packet Data session establishment or release and at each cell and/or Routing Area (RA) update to determine permanently the relevant IAs (and deduce, the possible LEAs within these IAs),
- concerning the IRI:
  - when an IA is left, a Mobile Station Detach event is sent when changing servicing 3 G G-SNs or a cell and/or RA update event is sent when changing IAs inside the same servicing 3G SGSN to DF2P.
  - when a new IA is entered a cell and/or RA update event is sent to DF2P and, optionally, a Start of Interception with Active PDP Context event for each PDP context
- concerning the CC, when crossing IAs, the CC is not sent anymore to the DF3P of the old IA but sent to the DF3P of the new IA.

## 7.1 Provision of Intercept Product - Short Message Service

Figure 19 shows an SMS transfer from the 3G SGSN node to the LEA. Quasi-parallel to the delivery from / to the mobile subscriber a message, which contains the content and header of the SMS, is generated and sent via the Delivery Function 2P to the LEA in the same way as the Intercept Related Information.

The IRI will be delivered to the LEA:

- for a SMS-MO, when the SMS-Centre receives the SMS;
- for a SMS-MT, when the MS receives the SMS.

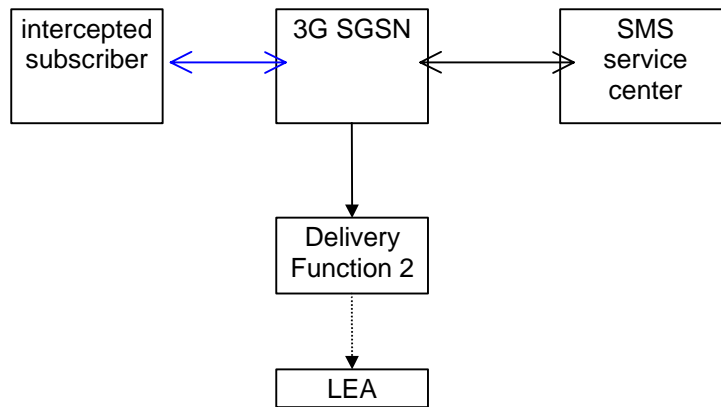

Figure 19: Provision of Intercept Product - Short Message Service

## 7.2 Provision of Intercepted Content of Communications – Packet data GSN services

The access method for the delivering of Packet Data GSN Intercept Product is based on duplication of packets without modification at 3G GSN. The duplicated packets with additional information in the header, as described in the following sections, are sent to DF3P for further delivery via a tunnel.

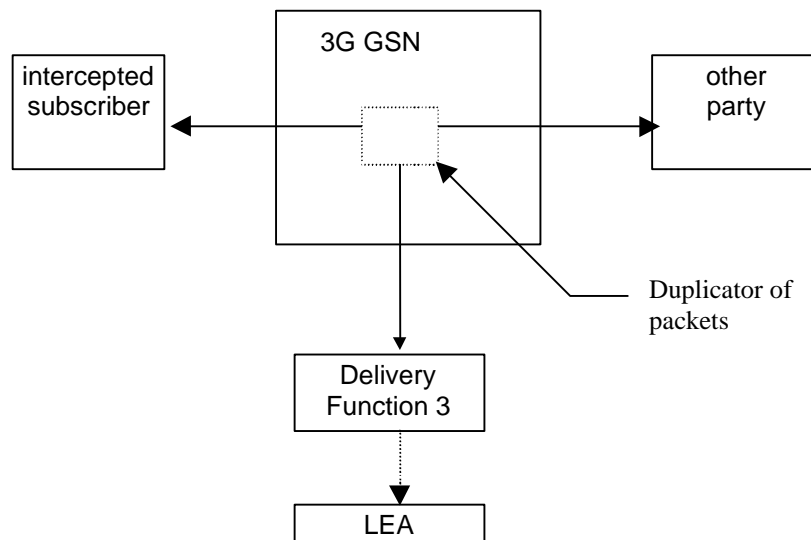

Figure 20: Configuration for interception of Packet Data GSN product data

### 7.2.1 X3p-interface

In addition to the intercepted ~~call~~ content of communications, the following information needs to be transferred from the 3G GSN to the DF3P in order to allow the DF3P to perform its functionality:

- target identity;
- correlation number;
- the target location (if available) or the IAs in case of location dependent interception.

Additional information may be provided as a national option.

## 7.3 Provision of Intercept Related Information

Intercept Related Information (Events) are necessary at the Mobile Station Attach, Mobile Station Detach, PDP Context Activation, Start of intercept with PDP context active, PDP Context Deactivation, Cell and/or RA update, and SMS events.

Figure 21 shows the transfer of intercept related information to the DF2P. If an event for / from a mobile subscriber occurs, the 3G GSN sends the relevant data to the DF2P.

See section 7A for multi-media Intercept Related Information produced at the CSCF.

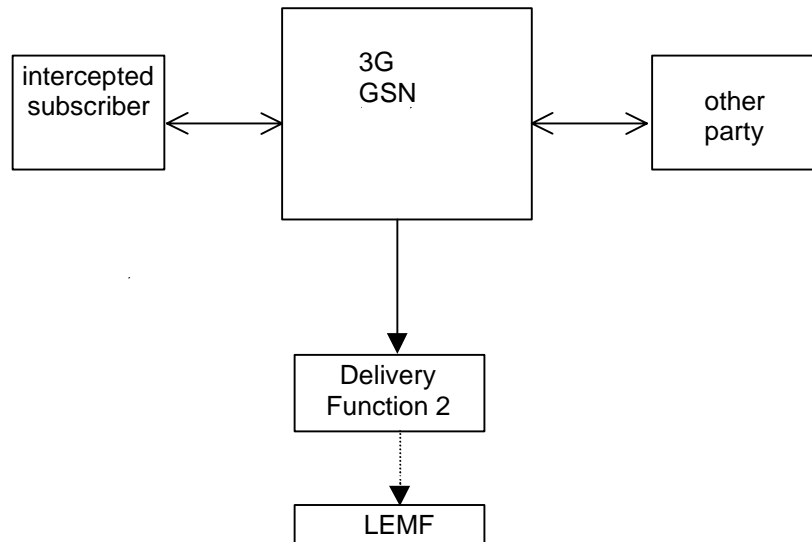

**Figure 21: Provision of Intercept Related Information**

### 7.3.1 X2p-interface

The following information needs to be transferred from the 3G GSN to the DF2P in order to allow a DF2P to perform its functionality:

- target identity (MSISDN, IMSI, IMEI);
- events and associated parameters as defined in section 7.3.2 and 7.4 may be provided;
- the target location (if available) or the IAs in case of location dependent interception.
- Correlation number

### 7.3.2 Structure of the events

There are seven different events in which the information is sent to the DF2P if this is required. Details are described in the following section. The events for interception are configurable (if they are sent to DF2P) in the 3G GSN and can be suppressed in the DF2P.

**The following events are applicable to 3G SGSN:**

- Mobile Station Attach;
- Mobile Station Detach;
- PDP context activation;
- Start of intercept with PDP context active;
- PDP context deactivation;

- Cell and/or RA update;
- SMS.

NOTE: 3G GGSN interception is a national option. Location information may not be available in this case.

The following events are applicable to the 3G GGSN:

- PDP context activation ;
- PDP context deactivation ;
- Start of interception with PDP context active.

A set of fields as shown below is used to generate the events. The events transmit the information from 3G GSN to DF2P. This set of fields as shown below can be extended in the 3G GSN, if this is necessary as a national option. DF2P can extend this information if this is necessary as a national option e.g. a unique number for each surveillance warrant.

**Table 2: Information Events for Packet Data Event Records**

Observed MSISDN MSISDN of the target subscriber (monitored subscriber)
Observed IMSI IMSI of the target subscriber (monitored subscriber)
Observed IMEI IMEI of the target subscriber (monitored subscriber), it shall be checked for each activation over the radio interface.
Event type Description which type of event is delivered: PDP attach, PDP detach, PDP context activation, Start of intercept with PDP context active, PDP context deactivation, SMS, Cell and/or RA update,
Event date Date of the event generation in the 3G GSN
Event time Time of the event generation in the 3G GSN
PDP address The PDP address of the target subscriber. Note that this address might be dynamic.
Access Point Name The APN of the access point. (Typically the GGSN of the other party)
Routing Area Code The routing area code of the target defines the RA in a PLMN.
PDP Type The used PDP type.
Correlation Number The correlation number is used to correlate CC and IRI.
SMS The SMS content with header which is sent with the SMS-service. The header also includes the SMS-Centre address.
<del>CGI Network Element Identifier</del> <del>Cell Global Identity Unique identifier for the element reporting the ICE.</del>
<del>Failed attach reason</del> <del>Reason for failed attach of the target subscriber.</del>
<del>Failed context activation reason</del> <del>Reason for failed context activation of the target subscriber.</del>
<del>IAs-<u>IAs</u></del> <del>The observed Interception Areas The observed Interception Areas</del>

## 7.4 Packet Data related events

### 7.4.1 Mobile Station Attach

For attach an attach-event is generated. When an attach activation is generated from the mobile to servicing 3G G SN this event is generated. These fields will be delivered to the DF22P if available:

Observed MSISDN
Observed IMSI
Observed IMEI
Event Type
Event Time
Event Date
<u>CGI Network Element Identifier</u>
Routing area code
Failed attach reason
IAs (if applicable)

### 7.4.2 Mobile Station Detach

For detach a detach-event is generated, this is for the common (end) detach. These fields will be delivered to the DF2P if available:

Observed MSISDN
Observed IMSI
Observed IMEI
Event Type
Event Time
Event Date
<u>CGI Network Element Identifier</u>
Routing Area code
IAs (if applicable)

### 7.4.3 Packet Data PDP context activation

For PDP context activation a PDP context activation-event is generated. When a PDP context activation is generated from the mobile to 3G GSN this event is generated. These fields will be delivered to the DF2P if available:

Observed MSISDN
Observed IMSI
Observed IMEI
PDP address of observed party
Event Type
Event Time
Event Date
Correlation number
Access Point Name
PDP Type
<u>CGI Network Element Identifier</u>
Routing area code
Failed context activation reason
IAs (if applicable)

#### 7.4.4 Start of interception with PDP context active

This event will be generated if interception for a target is started and if the target has at least one PDP context active. If more than one PDP context are open for each of them an event record is generated. These fields will be delivered to the DF2P if available:

Observed MSISDN
Observed IMSI
Observed IMEI
PDP address of observed party
Event Type
Event Time
Event Date
Correlation number
Access Point Name
PDP Type
<u>CGI Network Element Identifier</u>
Routing area code
IAs (if applicable)

#### 7.4.5 Packet Data PDP context deactivation

At PDP context deactivation a PDP context deactivation-event is generated. These fields will be delivered to the DF2P if available:

Observed MSISDN
Observed IMSI
Observed IMEI
PDP address of observed party
Event Type
Event Time
Event Date
Correlation number
Access point name
<u>CGI Network Element Identifier</u>
Routing area code
IAs (if applicable)

#### 7.4.6 Cell and/or RA update

For each cell and/or RA update an update-event with the fields about the new location is generated. These fields will be delivered to the DF2P if available:

Observed MSISDN
Observed IMSI
Observed IMEI
Event Type
Event Time
Event Date
<u>CGI Network Element Identifier</u>
Routing area code
IAs (if applicable)

#### 7.4.7 SMS

For MO-SMS the event is generated in the 3G SGSN, when the SMS-Centre successfully receives the SMS; for MT-SMS the event is generated in the 3G SGSN when the target receives the message. These fields will be delivered to the DF2P if available:

Observed MSISDN
Observed IMSI
Observed IMEI
Event Type
Event Time
Event Date
<u>CGI Network Element Identifier</u>
Routing area code
SMS
IAs (if applicable)

## 7.5 ~~Intercept cases for supplementary services~~

Supplementary services may be used with Packet Data. However they are not standardised and therefore Lawful Interception interwork cases can not be defined at the time of publication of this document.

---

## 7A Invocation of Lawful Interception for Packet Data Multi-media Service

### 7A.1 Provision of content of communications

Interception of the content of communications for GSN packet data services is explained in section 7.2. No additional content of communications intercept requirements are identified. (to be confirmed pending completion of multi-media stage 2 specifications) Activation and invocation of multi-media service does not produce interception of content of communications, which must be intercepted at the GSN under a separate activation and invocation.

### 7A.2 Provision of IRI

SIP messaging is reported as Intercept Related Information for the interception of multi-media service. As shown in figure 22 below, all SIP messages executed on behalf of a target subscriber are subject to intercept at the P CSCF and S CSCF. Based upon network configuration, the ADMF shall provision P CSCFs, or S CSCFs, or both P CSCFs and S CSCFs with SIP URL target identifiers. These resulting intercepted SIP messages shall be sent to DF2 for mediation prior to transmittal across the HI2 interface.

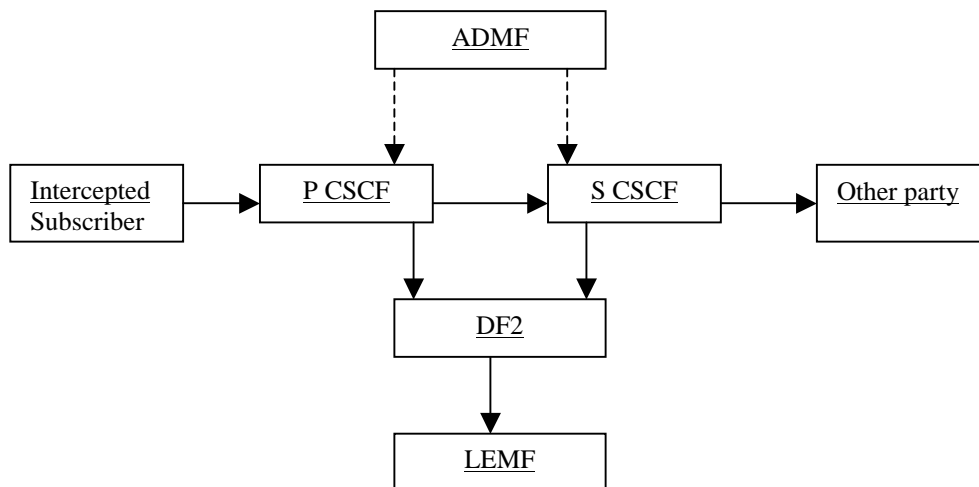

**Figure 22: Provision of Intercept Related Information for multi-media**

### 7A.3 Multi-media events

- All SIP messages to or from a targeted subscriber, and all SIP messages executed on behalf of a targeted subscriber for multi-media session control are intercepted by the P CSCF and S CSCF and sent to DF2. The target identifier used to trigger the intercept will also be sent with the SIP message. P CSCF event reports may be redundant with S CSCF event reports when the P CSCF and S CSCF reside in the same network, however, this standard does not require nor prohibit redundant information from being reported to DF2.
- [Editors note: The reporting of location information for the sake of location dependent intercept is for further study.]
- [Editors note: the use of a correlation ID for SIP to bearer correlation is a topic for further study.]
- An intercepted SIP event sent to DF2 is shown below:

- <u>Observed SIP URL</u>
- <u>Event Time and Date</u>
- <u>Network element identifier</u>
- <u>SIP Message Header</u>
- <u>SIP Message Payload</u>

### 7A.4 Multi-media Call State Control Service Scenarios

The following section shows the delivery of intercepted events and product under various call scenarios. The scenarios show where IRI and CC are intercepted, and whether the bearer is presented to DF3 as packet or circuit bearer.

[[[Editors note: Proposed scenarios to present. This section will be completed when basic service flows are defined

1. PS mobile to PS mobile CF to PS mobile
2. CS mobile to PS mobile CF to PSTN
3. PSTN to PS mobile CF PSTN
4. PDN to PS mobile CF to PDN
5. CS mobile to CS mobile CF to CS mobile
6. PS mobile to CS mobile CF to PS mobile
7. PSTN to CS mobile CF to PSTN
8. Multi-party calls with CS anchor
9. Multi-party calls with PS anchor]]]

---

## 88 Security

The security requirements are valid for the whole Lawful Interception system, i.e. rules and procedures shall be used for all involved entities, 3G GSN and the DF.



## 8.1 Administration security

The administration of the LI function, i.e. Activation, Deactivation and Interrogation of Lawful Interception, in the 3G GSN, ~~3G MSC~~ 3G INEs and the DFs shall be done securely as described below:

- It shall be possible to configure the authorised user access within the serving network to Activate, Deactivate and Interrogate Lawful Interception separately for every physical or logical port at the 3G INEs~~3G MSC~~ and DF. It shall be possible to password~~k~~ protect user access.
- Only the ADMF is allowed to have access to the LI functionality in the ~~3G MSC~~, ~~3G GSN~~3G INEs and DF.
- The communication links between ADMF, 3G GSN,~~3G MSC Server~~, CSCF, ~~DF2~~, ~~DF2P~~, and ~~DF3~~, ~~DF3P~~ may be required by national option to support security~~security~~ mechanisms. Options for security mechanisms include:
  - ~~—~~CUG / VPN;
  - ~~—~~COLP;
  - CLIP
  - authentication;
  - encryption.

Through the use of user access restrictions, no unauthorised network entities or remote equipment shall be able to view or manipulate LI data in the 3G GSN, 3G MSC Server, CSCF or the DFs.

## 8.2 IRI security

### 8.2.1 Normal operation

The transmission of the IRI shall be done in a secure manner.

When DFs are physically separate from the ~~3G MSC~~ and ~~3G GSN~~3G INEs, the X2 and ~~X2p~~ interfaces may be required by national option to support security mechanisms. Options for security mechanisms include:

- CUG/VPN;
- ~~—~~COLP;
- CLIP
- authentication;
- encryption.

### 8.2.2 Communication failure

Depending on the national law in case of communication failure IRI may be buffered in the ~~3G MSC~~ and ~~3G GSN~~3G INEs. After successful transmission of IRI the whole buffer shall be deleted. It shall be possible to delete the content buffer via command or a timer, in an unrestoreable fashion.

## 8.3 CC security

The transmission of the CC shall be done in a secure manner.

When DFs are physically separate from the ~~3G MSC~~ and ~~3G GSN~~3G INEs, the X3 and ~~X3p~~ interfaces may be required by national option to support security mechanisms. Options for security mechanisms include:

- CUG/VPN;

- ~~\_\_\_~~COLP;
- CLIP
- authentication;
- encryption.

In case of transmission failure no buffering is required within the intercepting network.

## 8.4 Security aspects of Lawful Interception billing

Billing information may be suppressed or made available at the DFs and the ADMF. Billing information for Lawful Interception shall be separated from "regular" billing data.

Billing data transmission to the Lawful Interception billing system may be done in a secure manner per national option.

In case of transmission failure billing-data shall be buffered/stored in a secure way. After successful transmission billing data shall be deleted in an unrestorable fashion.

## 8.5 Other security issues

### 8.5.1 Log files

Log files shall be generated by the ADMF, DF2, ~~DF2P~~, DF3, ~~DF3P~~, 3G MSC Server, CSCF and the 3G GSN. All log files are retrievable by the ADMF, and are maintained by the ADMF in a secure manner.

### 8.5.2 Data consistency

The administration function in the 3GMSPLMN shall be capable to perform a periodic consistency check to ensure that the target list of MSISDN, IMSI or IMEI target identities is the same in all involved 3G MSC Servers, CSCFs, and 3G GSNs in the PLMN-3GMS and the DFs contain the appropriate target Ids consistent with the intercept orders in the ADMF. The reference data base is the ADMF data base.

# Annex A (informative): Information flows for Lawful Interception invocation of circuit switched services

The following figures show the information flows for the invocation of Lawful Interception for various types of calls. The figures show some of the basic signalling messages of the target calls and the events on the X2 and X3-interfaces. The ISUP messages to and from the network are shown for informational purposes only; some of them may not be sent or may be combined in certain networks.

To be updated to include MGW. { For next meeting }

## A.1 Mobile originated circuit switched calls

Figure A1 shows the interception of a basic mobile originated circuit switched speech or data call where the originating mobile (A) is the target for interception. B is not necessarily also a mobile subscriber and resides on a different exchange.

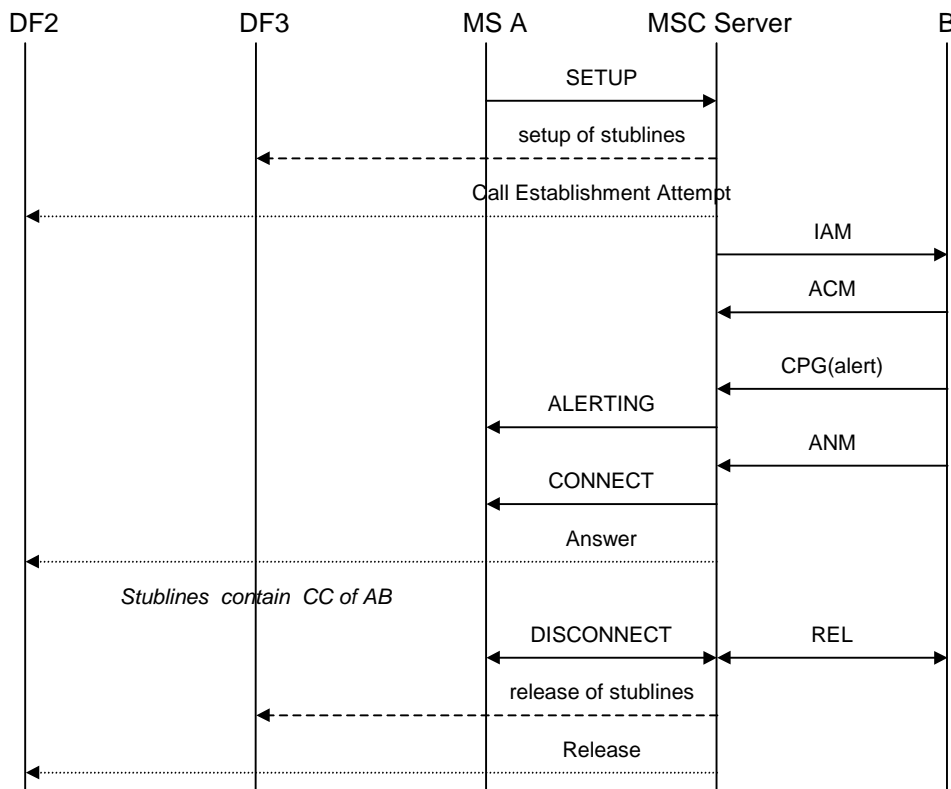

**Figure A1: Interception of mobile originated circuit switched calls**

In figure A1 the result (answer) of the set-up of the stublines is not shown. This assumes no special action is taken in case of failure.

## A.2 Mobile terminated circuit switched calls

Figure A2 shows the interception of a basic mobile terminated circuit switched speech or data call where the terminating mobile (B) is the target for interception. A is not necessarily also a mobile subscriber and resides on a different exchange.

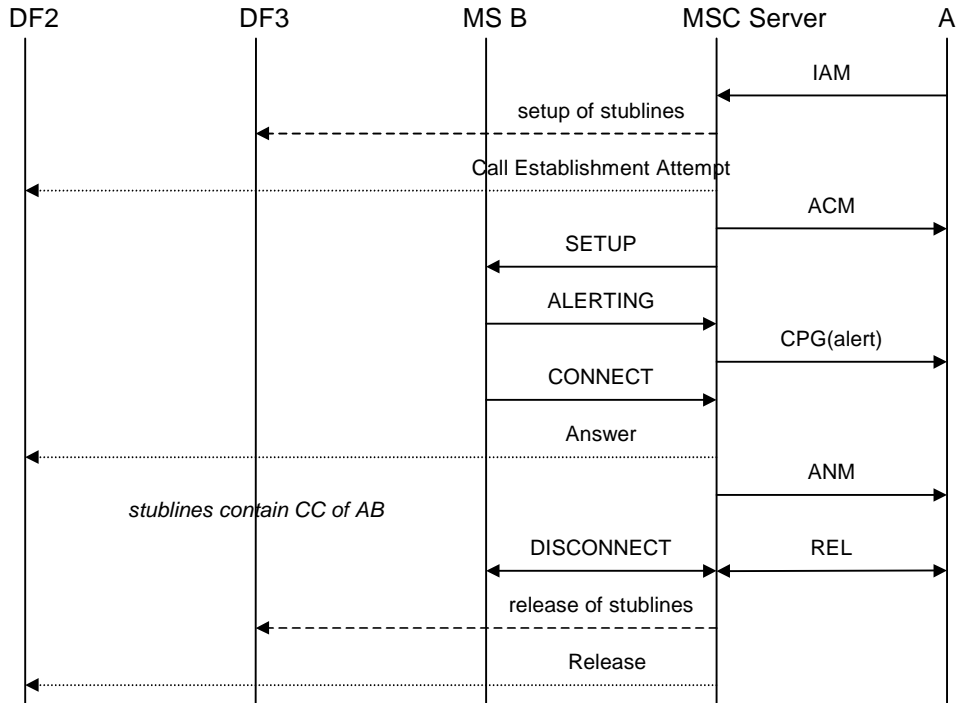

Figure A2: Interception of mobile terminated circuit switched calls



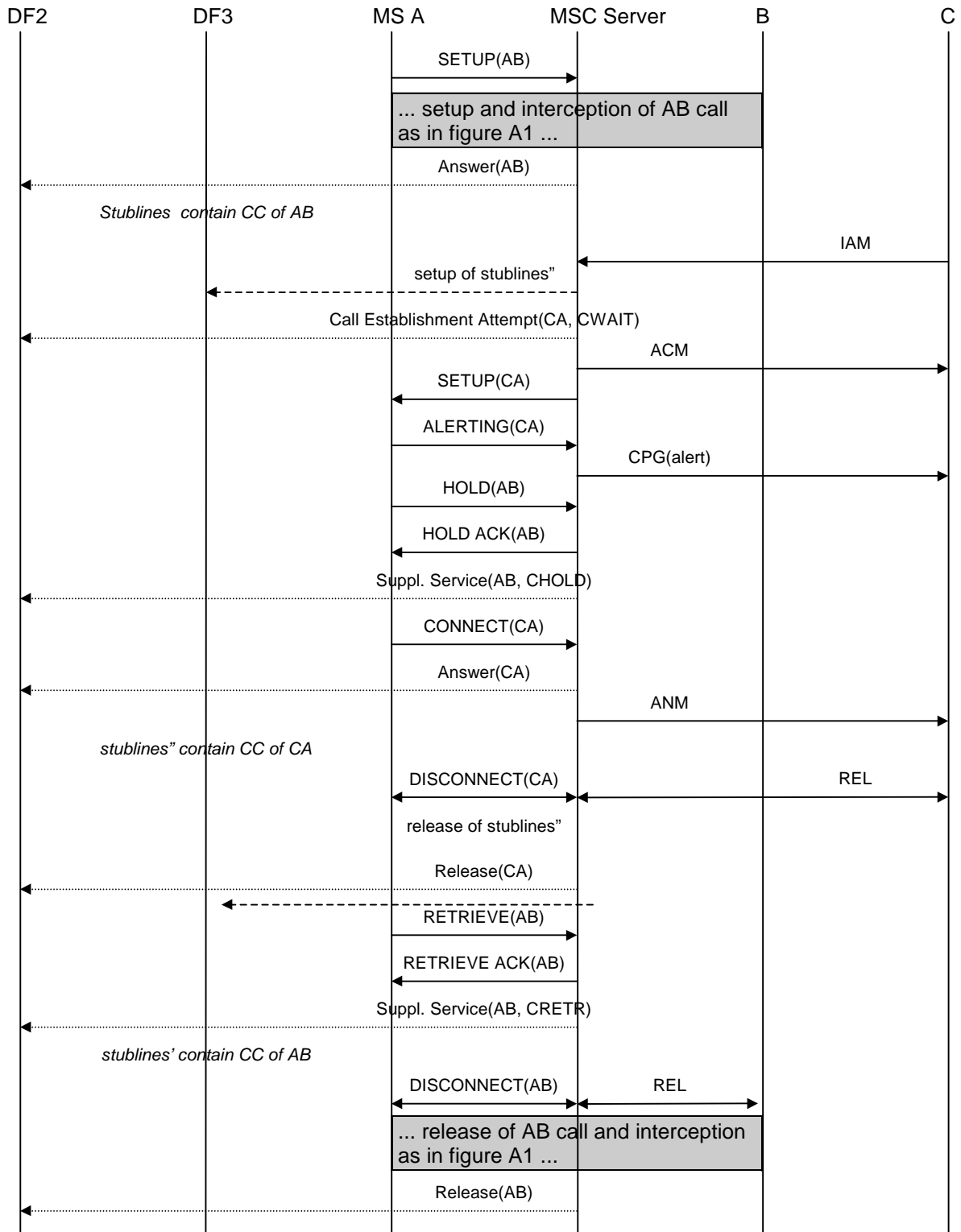

Figure A4: Interception of call hold / call waiting - stublines per target call

## A.4 Multiparty calls

Figures A5 and A6 show the interception of multiparty calls. Figure A5 covers the case where one stubline or one pair of stublines is used per target, figure A6 covers the case where a separate stubline or pair of stublines is used for each target call. The mobile setting up the multiparty call (A) is the target for interception.

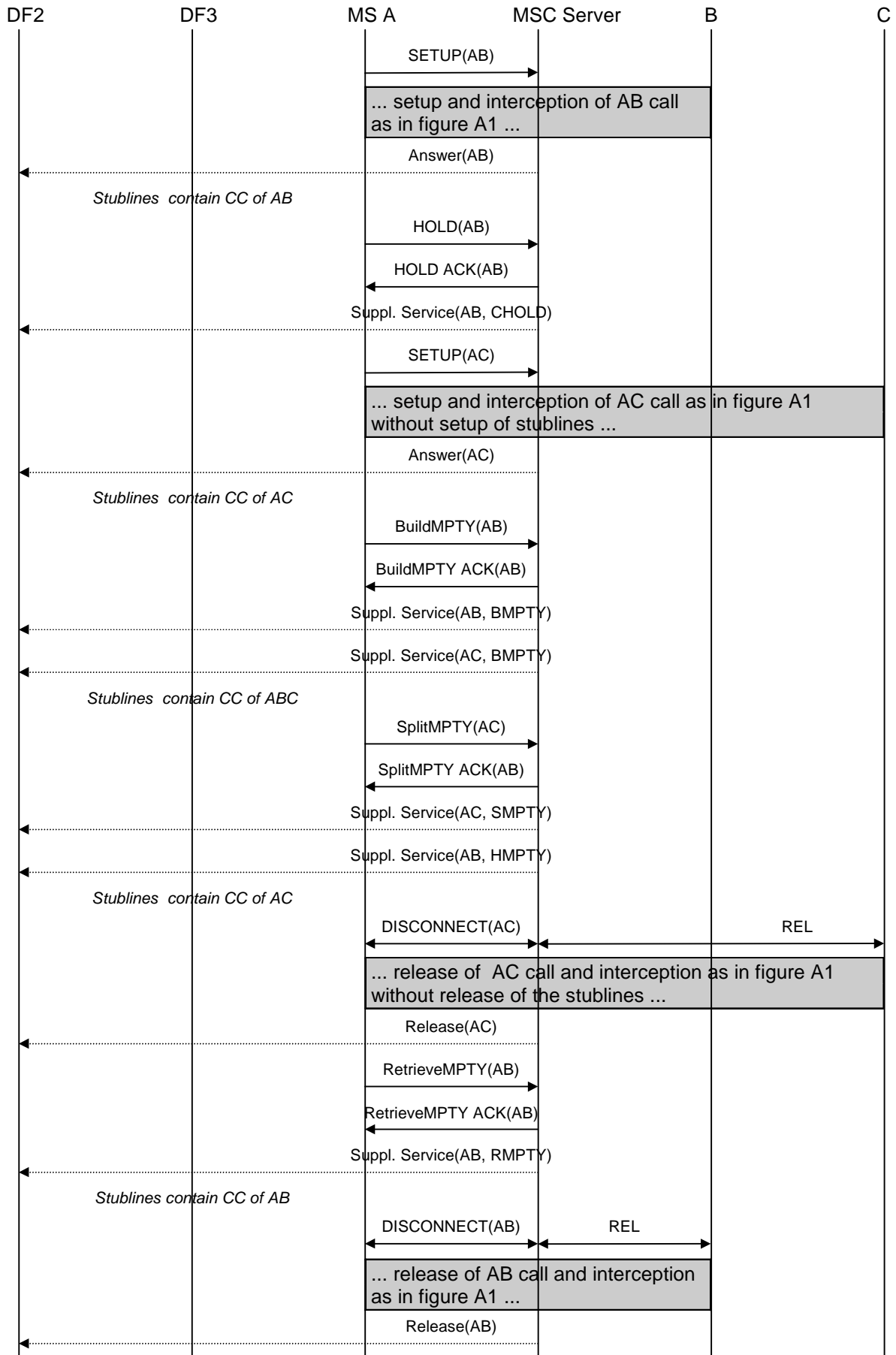

Figure A5: Interception of multiparty calls - stublines per target

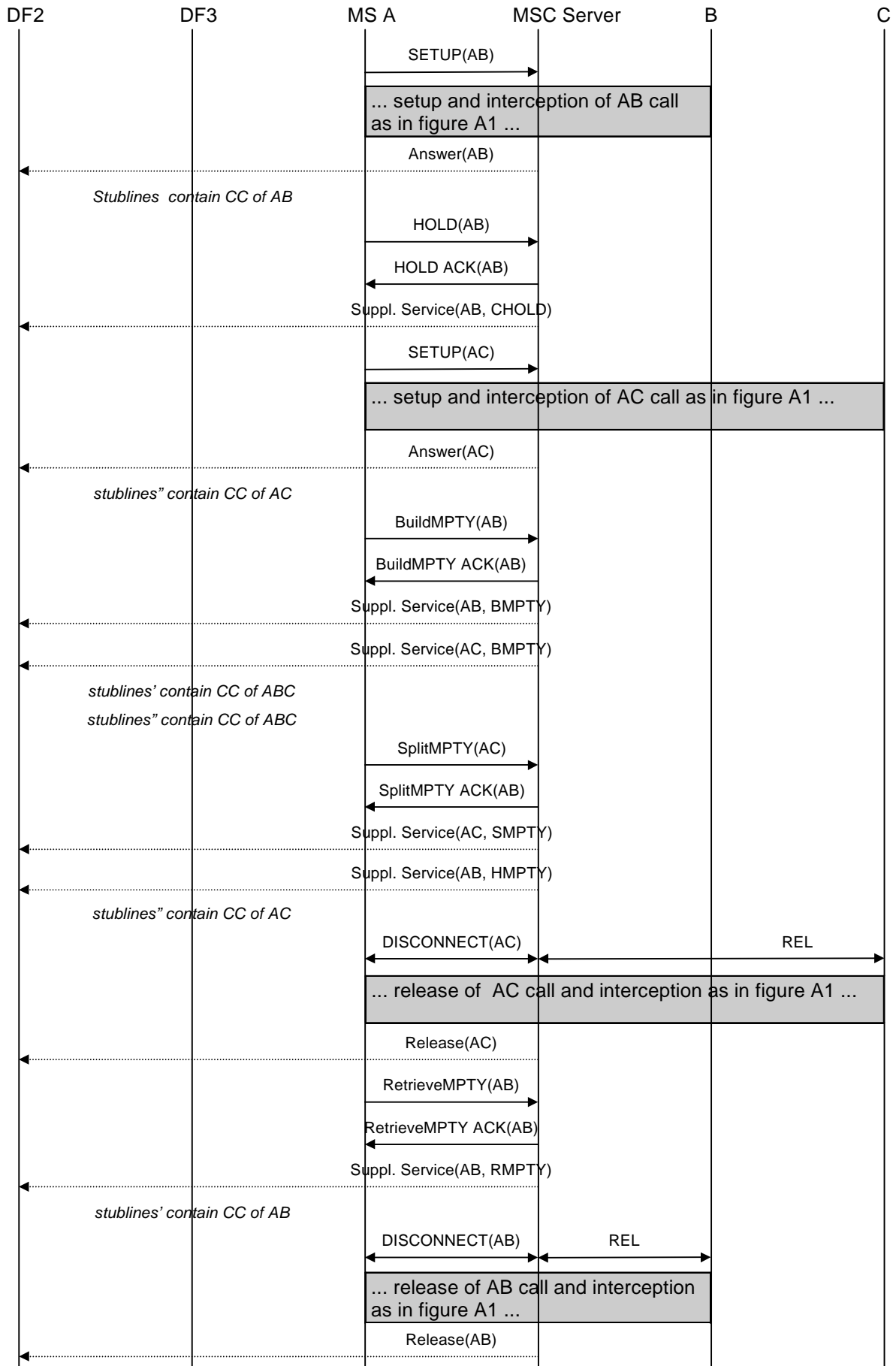

Figure A6: Interception of multiparty calls - stublines per target call



## A.5 Call forwarding / call deflection

The following pictures show the information flows for the interception of forwarded calls. Information flows will be given for three typical cases of call forwarding. All other types of call forwarding / call deflection are intercepted similar to one of these.

### A.5.1 Unconditional call forwarding

Figure A7 shows the interception of unconditionally forwarded calls. The mobile that activated unconditional call forwarding (B) is the target for interception. In this case interception will be performed at the 3G GMSC, where the Service Request Indicator (SRI) request for B is issued and subsequently the SRI response indicating that the call shall be forwarded is received.

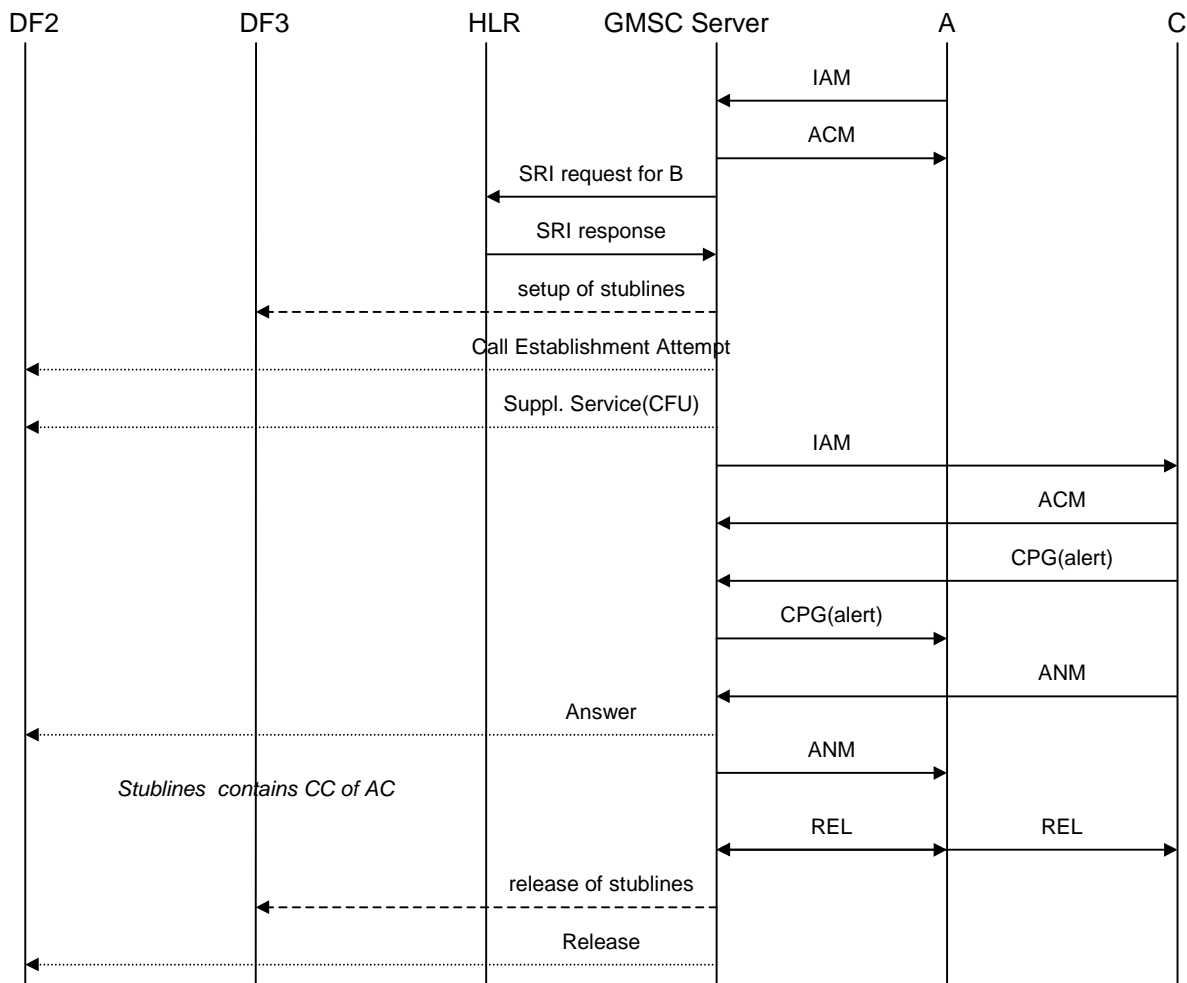

Figure A7: Interception of unconditional call forwarding

### A.5.2 Call forwarding on not reachable (IMSI detached)

Call forwarding on not reachable because the IMSI is detached is also handled on the 3G GMSC. Interception of this type of call forwarding is similar to interception of unconditional call forwarding.

### A.5.3 Call forwarding on busy (network determined)

Figure A8 shows the interception of call forwarding on busy (network determined). The mobile that activated call forwarding on busy (B) is the target for interception. In this case interception will be performed at the 3G MSC where B resides, where the busy condition is detected and the call is forwarded.

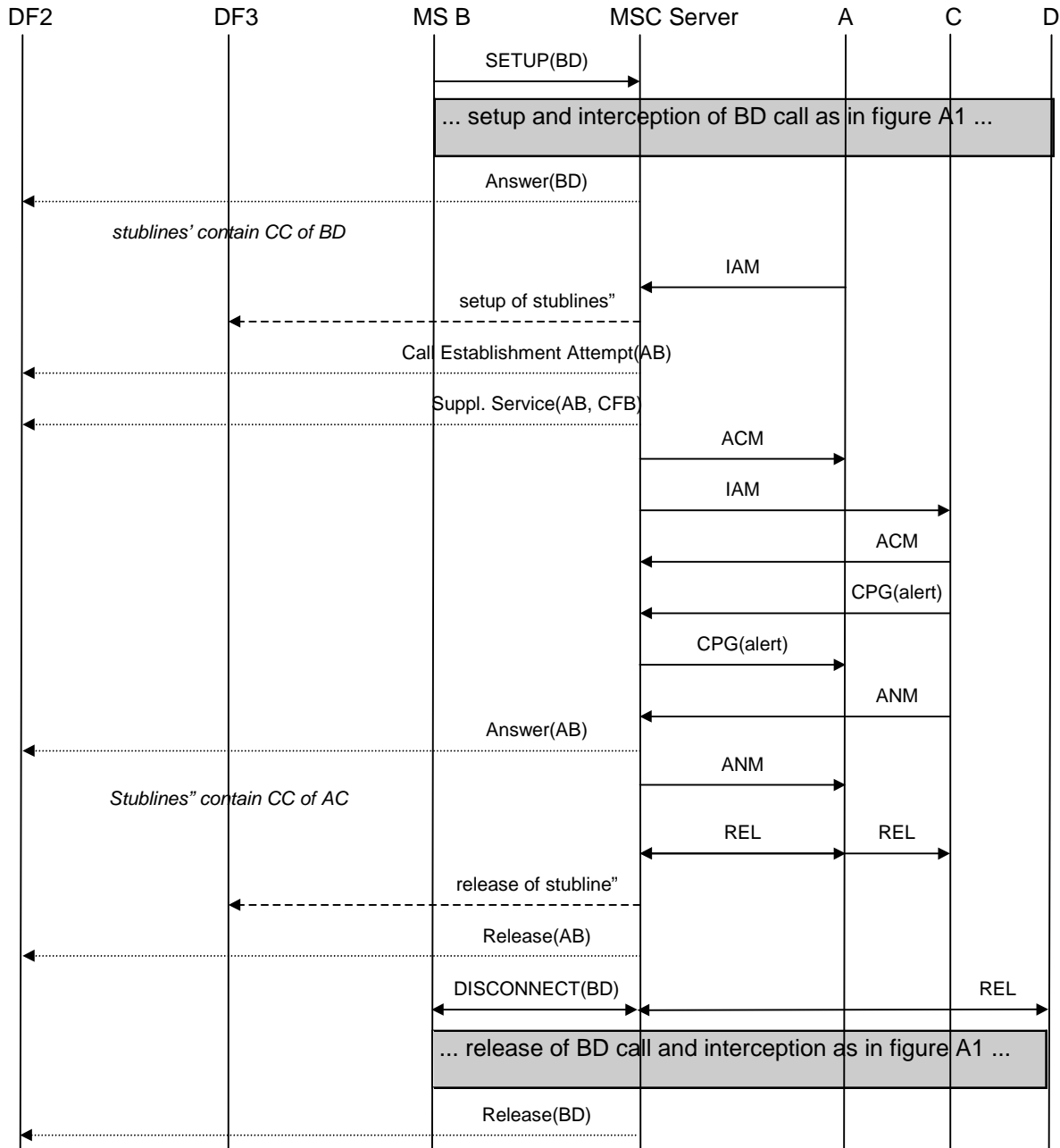

**Figure A8: Interception of call forwarding on busy (network determined)**

### A.5.4 Call forwarding on not reachable (no response to paging/radio channel failure)

Call forwarding on not reachable because of no response to paging or radio channel failure is also handled on the 3G MSC similar to call forwarding on busy (network determined). Interception of this type of call forwarding is therefore done in the same way. (see section A.5.3)

### A.5.5 Call forwarding on no reply

Figure A9 shows the interception of call forwarding on no reply. The mobile that activated call forwarding on no reply (B) is the target for interception. In this case interception will be performed at the 3G MSC where B resides, where the no reply condition is detected and the call is forwarded. Initially, the interception is similar to the interception of a basic mobile terminated circuit switched speech or data call. On no reply time-out, the interception will continue on the forwarded call to C.

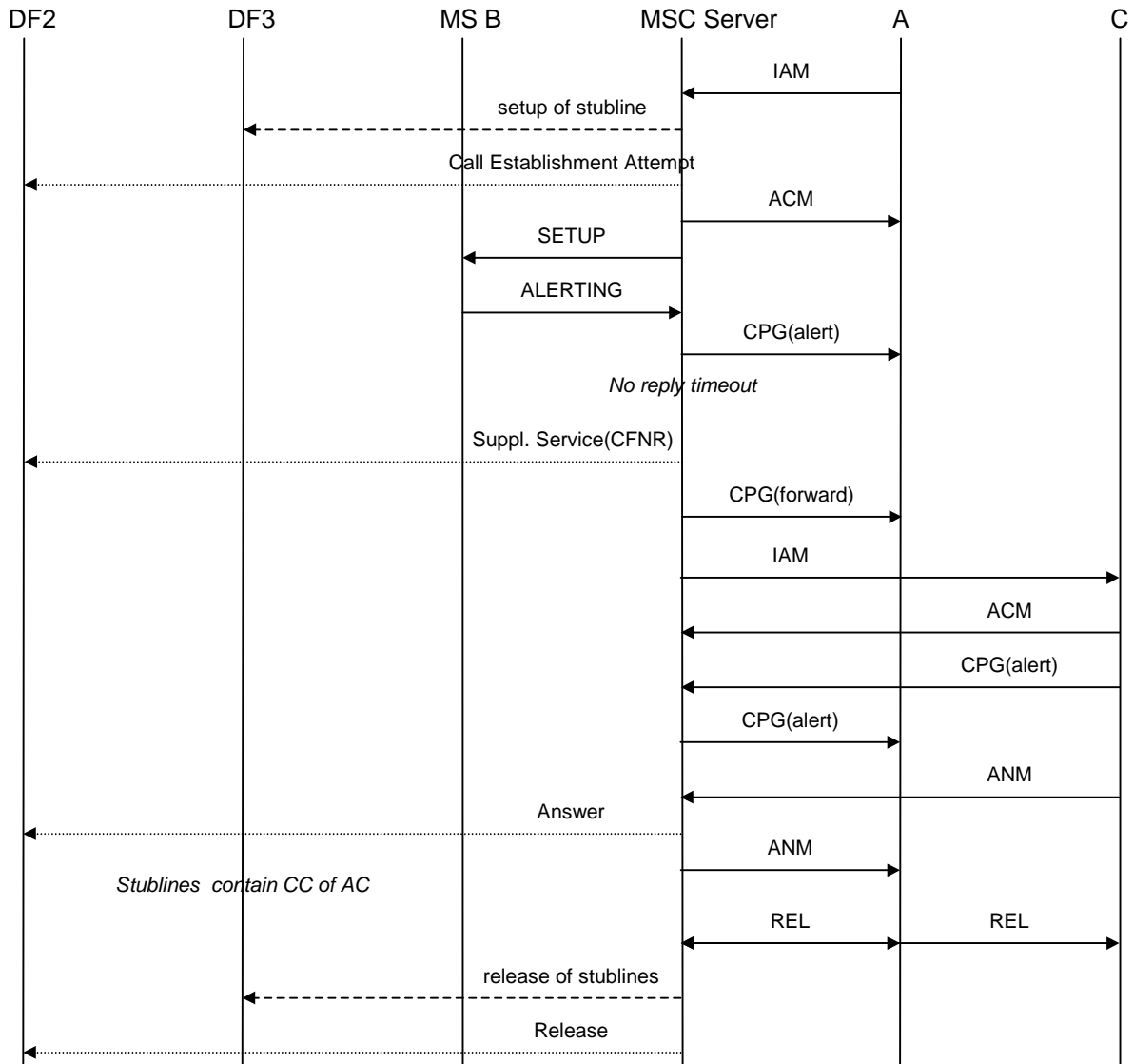

**Figure A9: Interception of call forwarding on no reply**

In figure A9 the release of the stublines is done after the forwarded call is released by A or C. It is a national option not to support interception of forwarded calls. In that case, the release of the stublines is done after the call is forwarded and B is no longer involved.

### A.5.6 Call forwarding on busy (user determined)/call deflection

Call forwarding on busy (user determined) and call deflection are also handled on the 3G MSC similar to call forwarding on no reply. Interception of this type of call forwarding is therefore done in the same way. (see A5.5)

### A.5.7 Call waiting / call forwarding on no reply

Figures A10 and A11 show the interception of a call involving both call waiting and call forwarding on no reply. Figure A10 covers the case where one stubline or one pair of stublines is used per target, figure A11 covers the case where a separate stubline or pair of stublines is used for each target call. The mobile that activated call forwarding on no reply and receives the waiting call (B) is the target for interception. In figure A10 a new (pair of) stublines needs to be set up when the call is forwarded since the first (pair of) stublines is still used for the initial call.

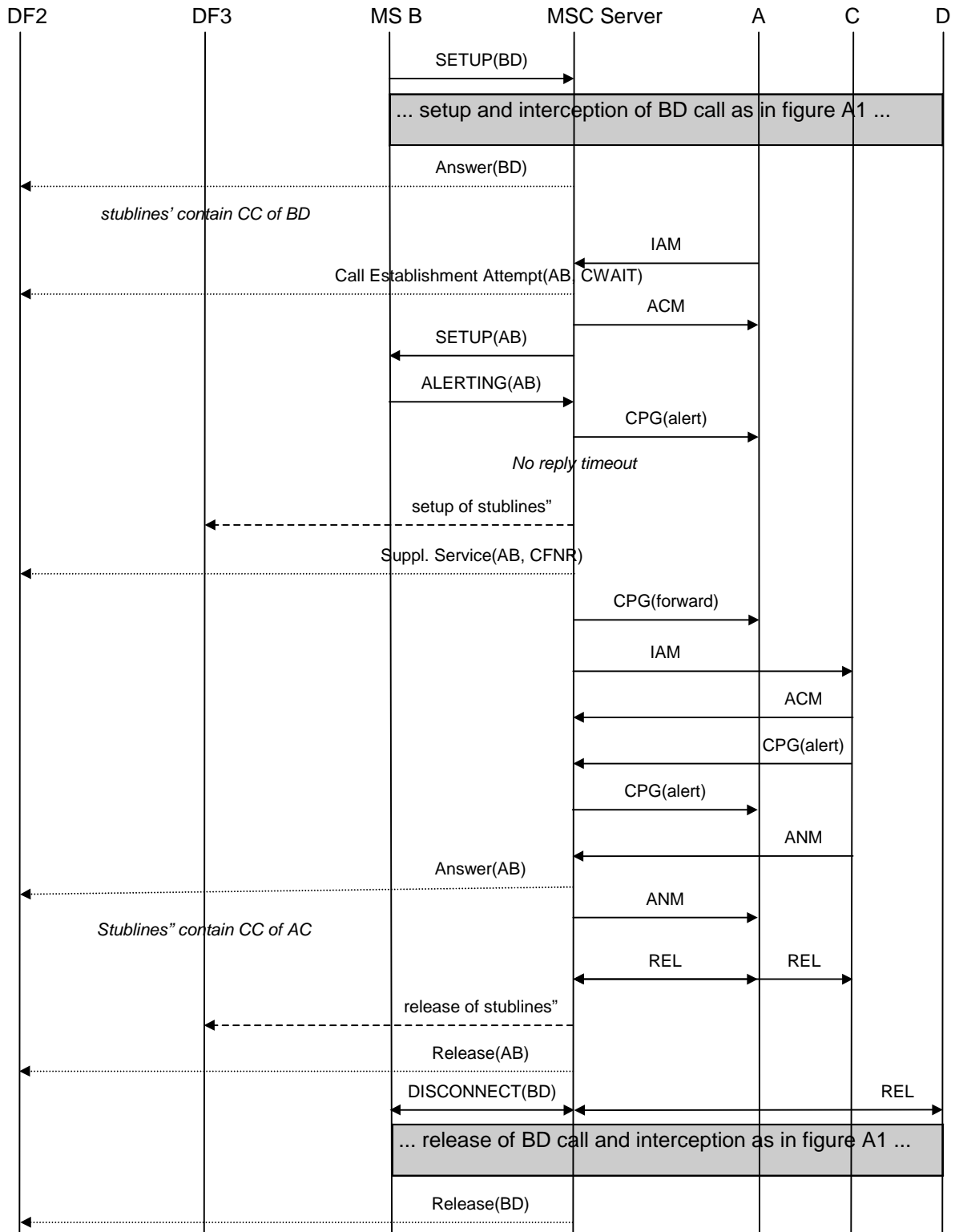

Figure A10: Interception of call waiting / call forwarding on no reply - stublines per target

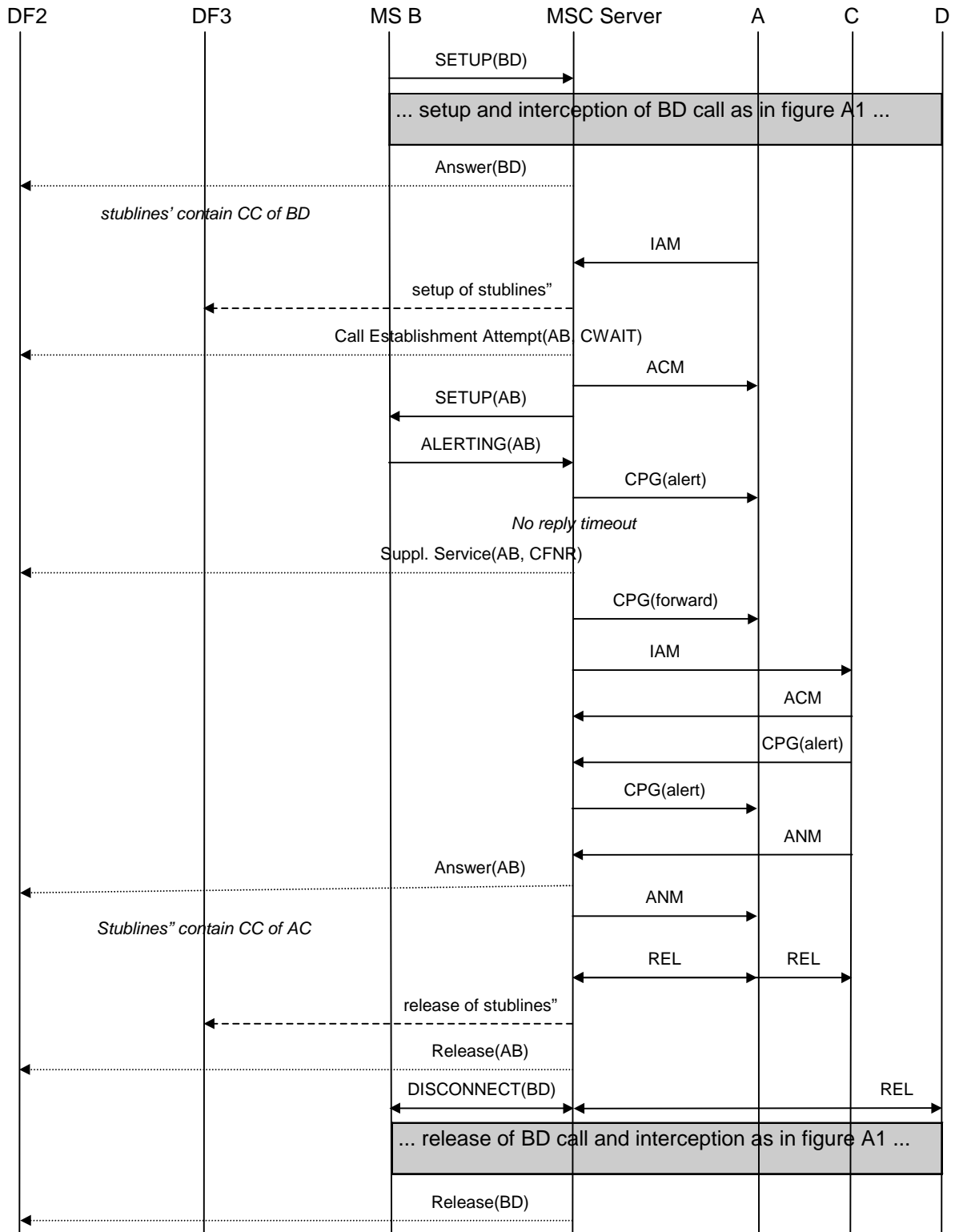

Figure A11: Interception of call waiting / call forwarding on no reply - stublines per target call

## A.6 Explicit call transfer

Figures A12 and A13 show the interception of explicit call transfer. Figure A12 covers the case where one pair of stublines is used per target, figure A13 covers the case where a separate pair of stublines is used for each target call. The mobile transferring the call (B) is the target for interception.

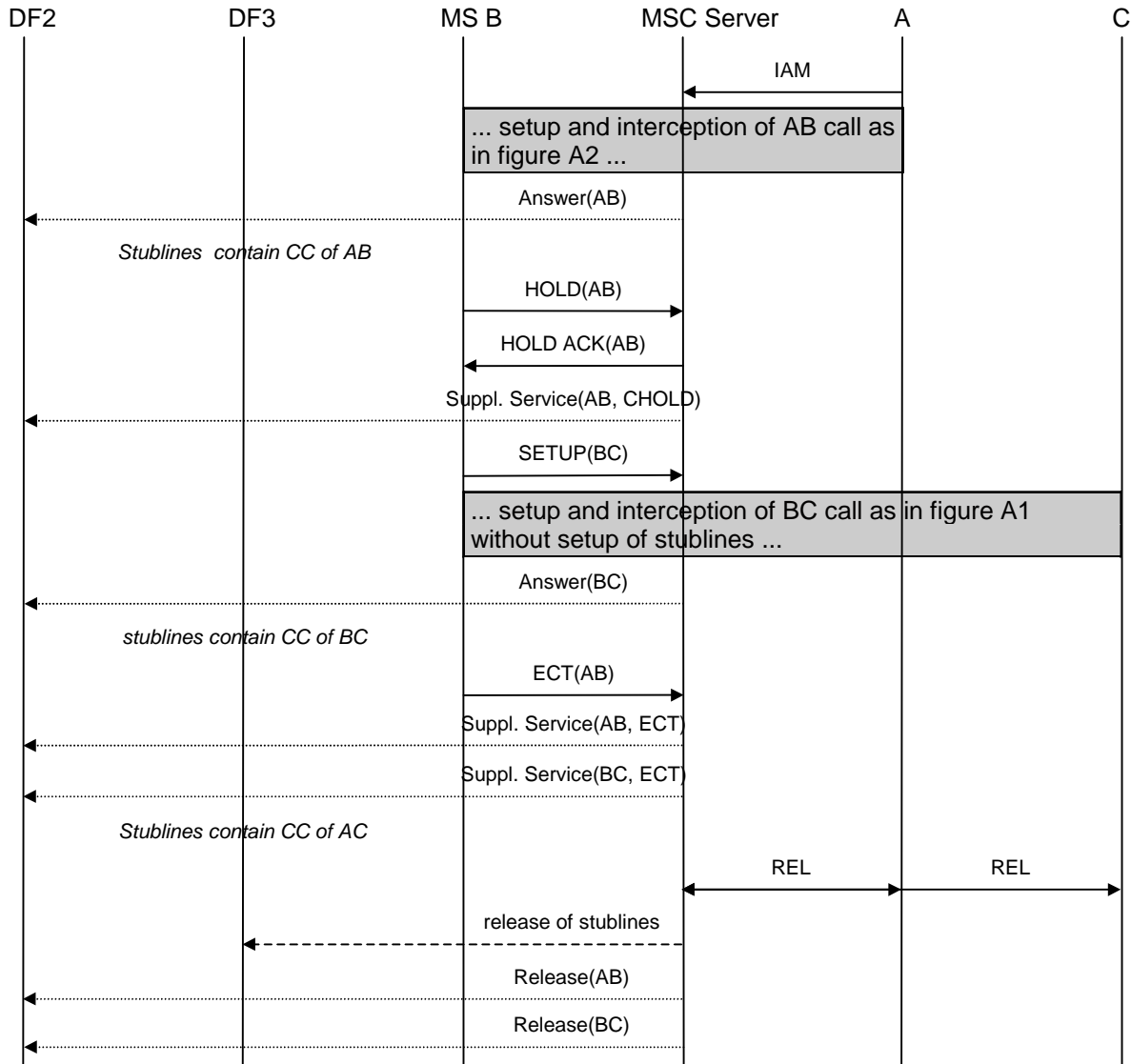
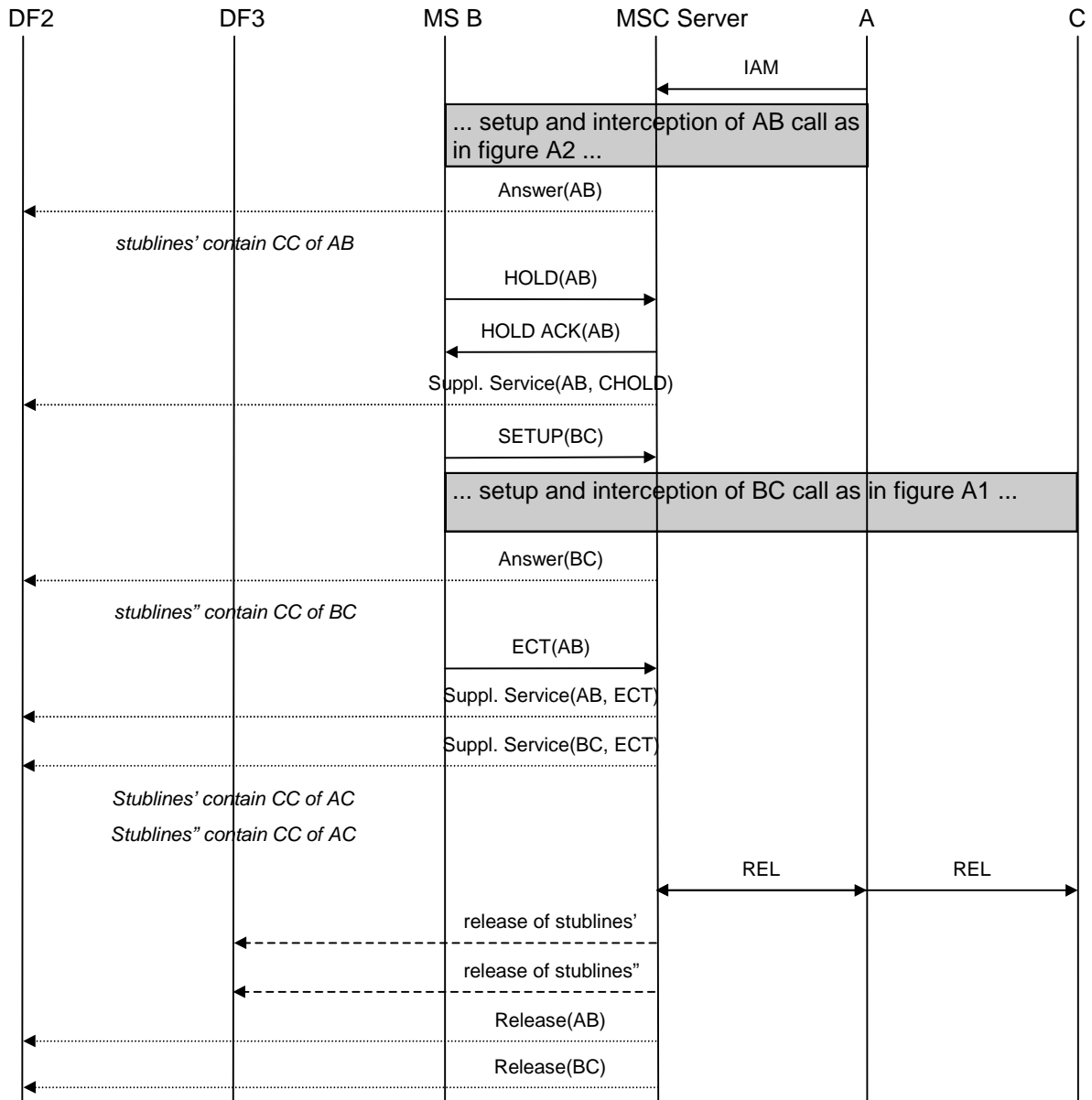

Figure A12: Interception of explicit call transfer - stublines per target



**Figure A13: Interception of explicit call transfer - stublines per target call**

In figures A12 and A13 the release of the stublines is done after the transferred call is released by A or C. It is a national option not to support interception of transferred calls. In that case, the release of the stublines is done after the call is transferred and B is no longer involved.

## Annex B (informative): Information flows for Lawful Interception invocation of GSN Packet Data services

The following figures show the information flows for the invocation of Lawful Interception for Packet Data and typical scenarios. The figures show some of the basic signalling messages of the target Packet Data communication and the events on the X2P and X3P interfaces. The dotted lines indicate signalling depending on whether CC and/or IRI information has been requested. The Gateway 3G GGSN may setup/release packet tunnels and send IRI information depending on national requirements.

The use of the Gateway 3G GGSN for interception is a national option.

### B.1 Mobile Station Attach

Figure B1 shows the interception of a basic Mobile Station Attach where the mobile (A) is the target for interception.

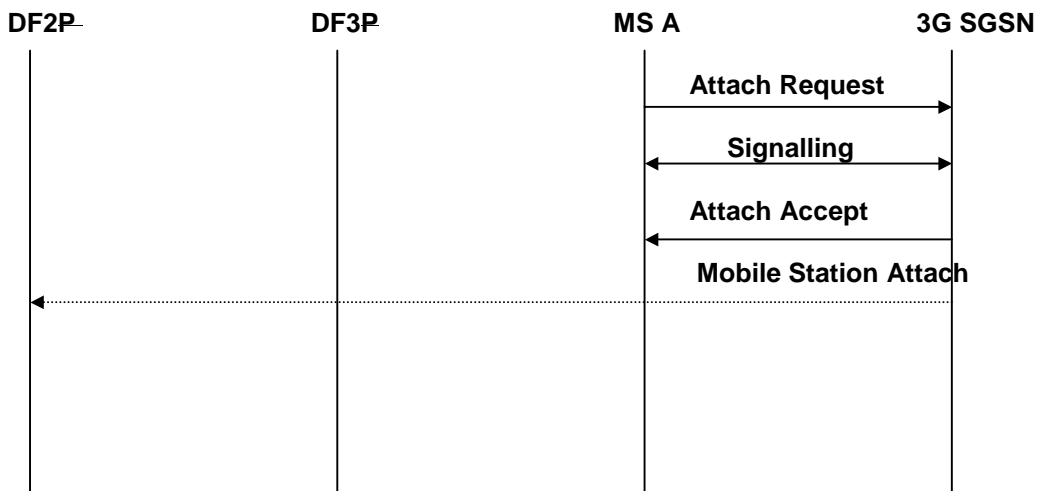

Figure B1: Interception of mobile originated Mobile Station Attachment



## B.2 Mobile Initiated Mobile Station Detach

Figure B2 shows the interception of a Mobile Initiated Mobile Station Detach where the originating mobile (A) is the target for interception.

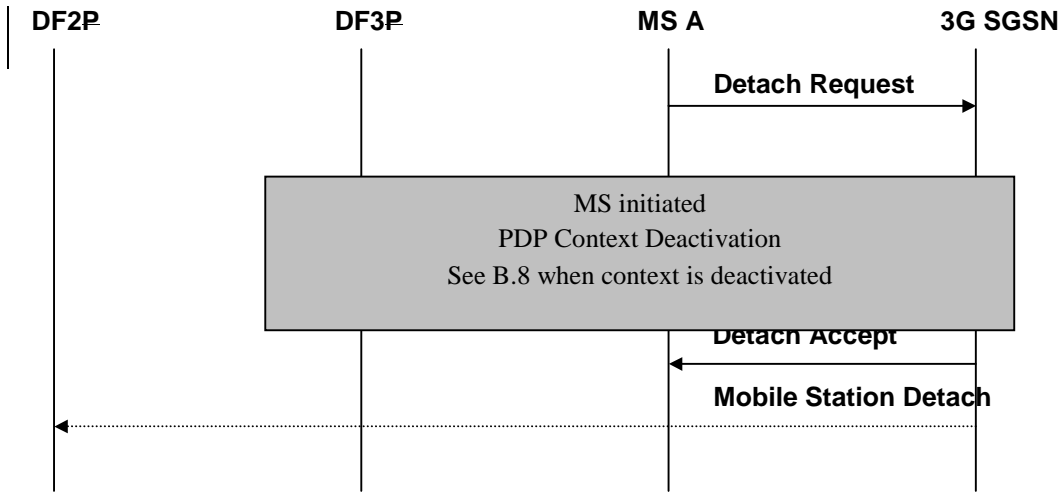
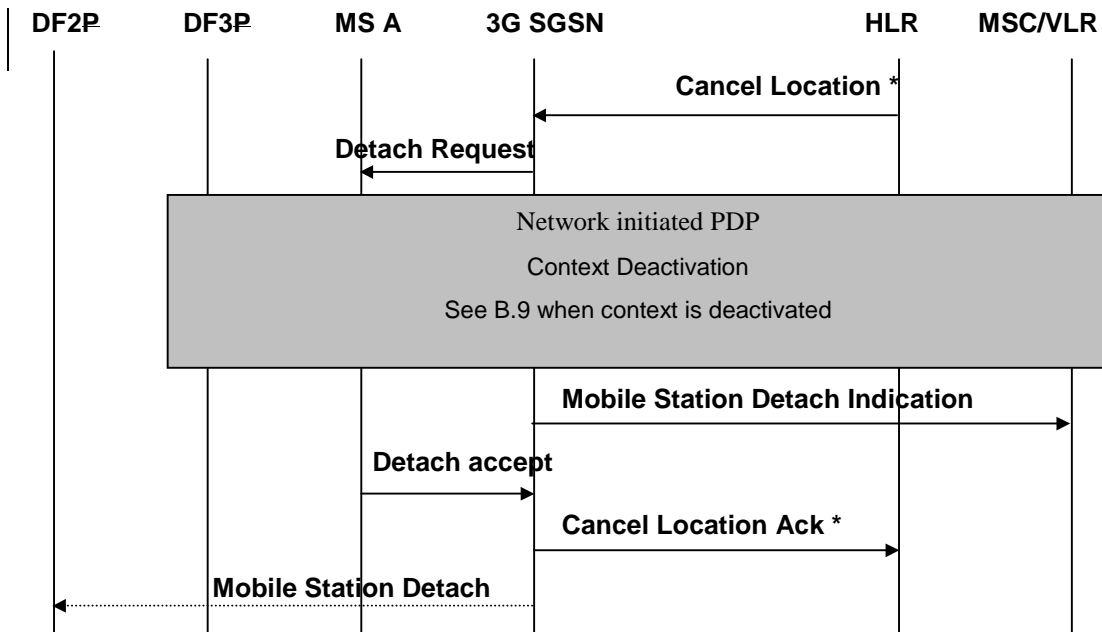

Figure B2: Interception of mobile originated Mobile Station Detachment

### B.3 Network initiated Mobile Station Detach

Figure B3 shows the interception of a network initiated (by 3G SGSN or HLR) Mobile Station Detach where the mobile (A) is the target for interception.



NOTE: \* Additional signals in case of HLR initiated

Figure B3: Interception of network initiated Mobile Station Detach.

### B.4 Intra 3G -GSN Routing Area Update

Figure B4 shows the interception of an Intra Routing Area Update where the mobile (A) is the target for interception. The sequence is the same for the combined RA / LA Update procedure but additional signalling is performed between the current 3G SGSN and the prior 3G SGSN before the Routing Area Update Accept message is sent to the MS.

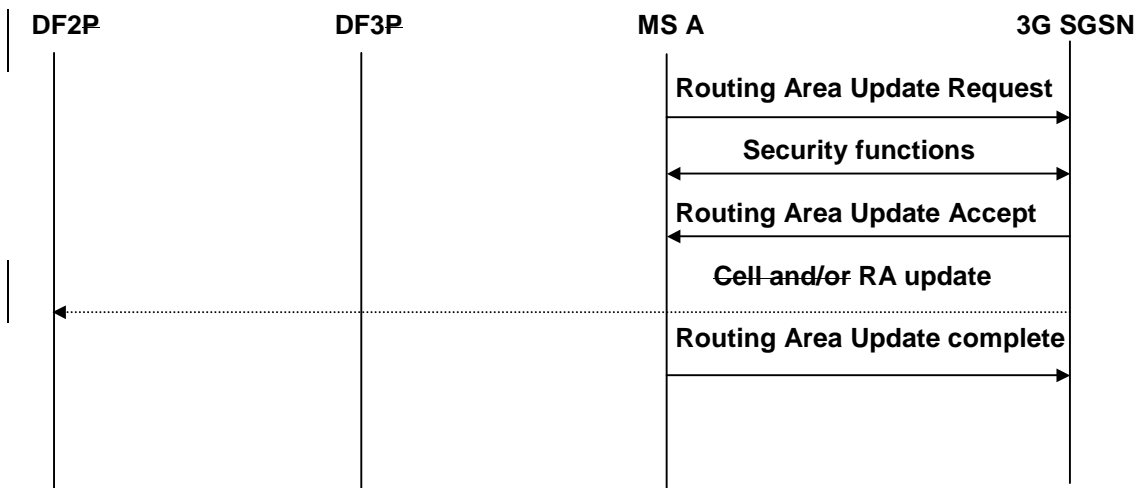

Figure B4: Interception of an Intra Routing Area Update

## B.5 Inter 3G GSN Routing Area Update

Figure B5 shows the interception of an Inter Routing Area Update where the mobile (A) is the target for interception. The sequence is the same for the combined RA / LA Update procedure but additional signalling is performed between the 3G GSN, HLR and the old 3G GSN before the Routing Area Update Accept message is sent to the MS. In case of PDP context not being active less signalling is required.

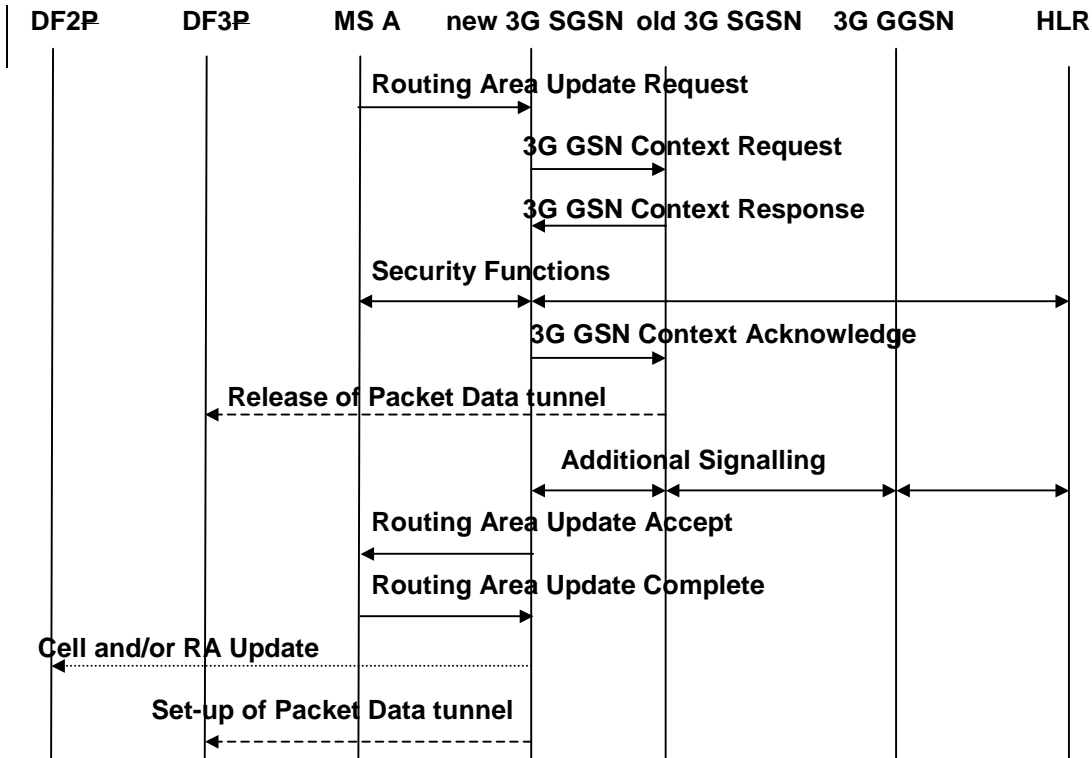

Figure B5: Interception of an Inter Routing Area Update

## B.6 PDP Context Activation

Figure B6 shows the interception of a PDP Context activation where the mobile (A) is the target for interception. The sequence for a network initiated PDP Context activation is analogous but is preceded by the 3G GSN sending a Request PDP Context Activation to the MS.

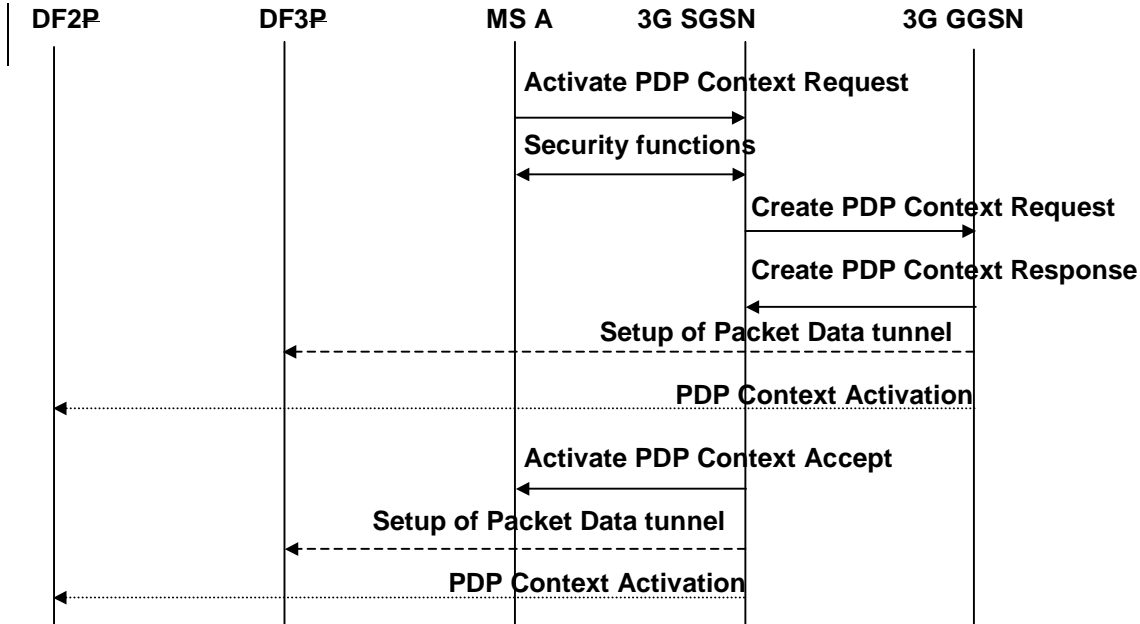

Figure B6: Interception of a PDP Context Activation

## B.7 Start of interception with PDP context active

A tunnel is established to DF3P and an event is sent to DF2P.

## B.8 MS initiated PDP Context Deactivation

Figure B7 shows the interception of a MS initiated PDP Context deactivation where the mobile (A) is the target for interception.

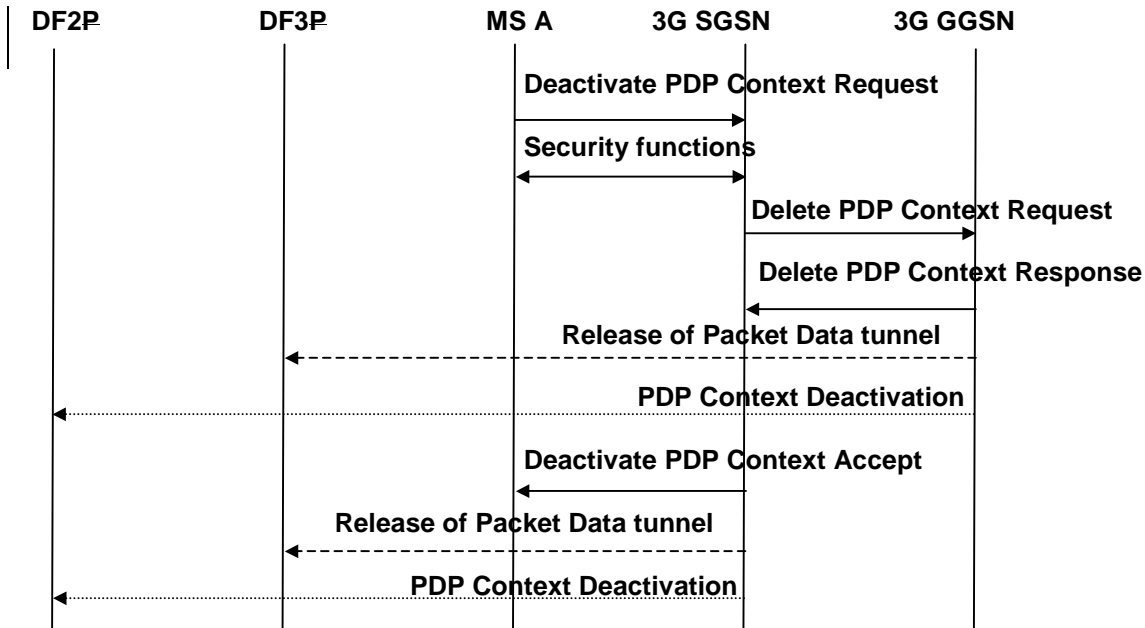

Figure B7: Interception of a PDP Context Deactivation

## B.9 Network initiated PDP Context Deactivation

Figure B8 shows the interception of a Network initiated PDP Context deactivation where the mobile (A) is the target for interception. The 3G GGSN may send, (depending on national requirements) the PDP Context deactivation and release the Packet Data tunnel after the Delete PDP Context Response has been sent or received, (signalling between the 3G SGSN and the 3G GGSN is not shown here).

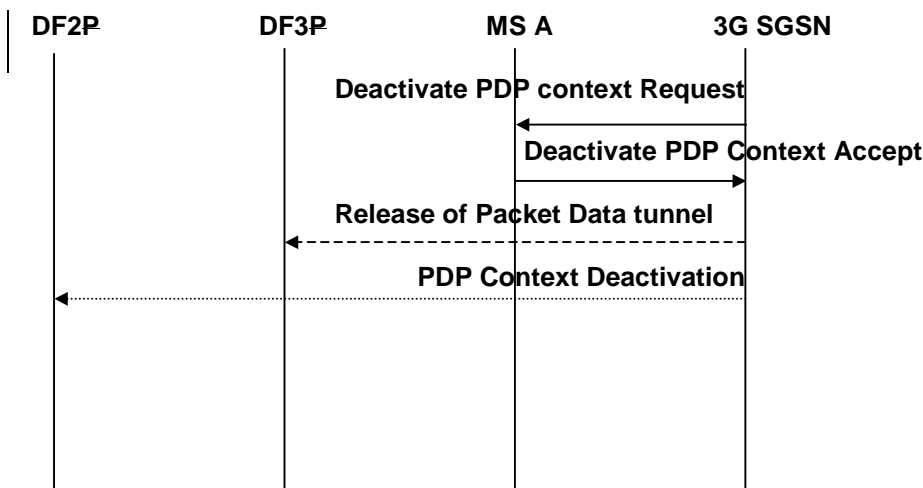

Figure B8: Interception of a Network initiated PDP Context Deactivation

## B.10 SMS

Figure B9 and B10 show the interception of a Mobile-terminated SMS and a Mobile-originated SMS transfer where the mobile (A) is the target for interception.

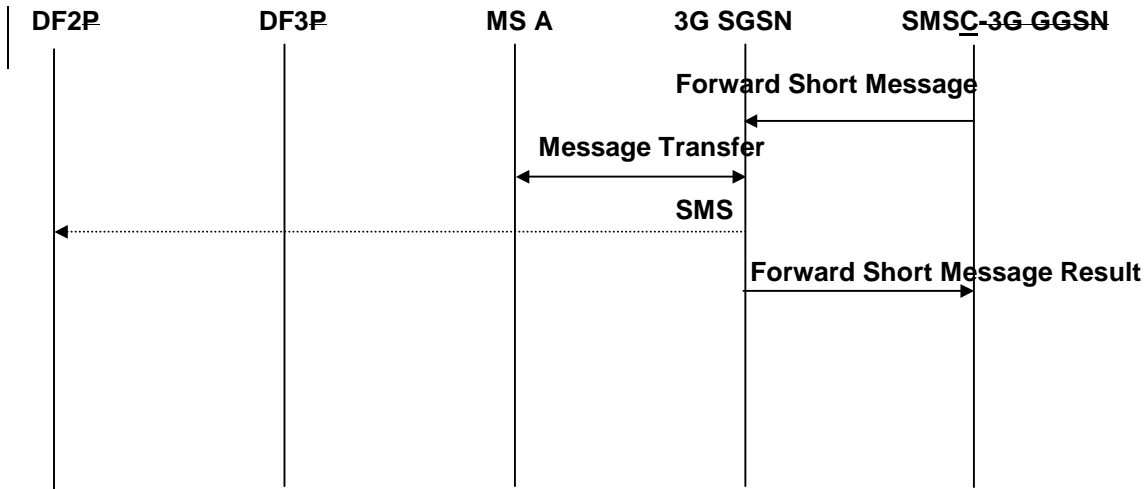

Figure B99: Interception of a Mobile-terminated SMS transfer

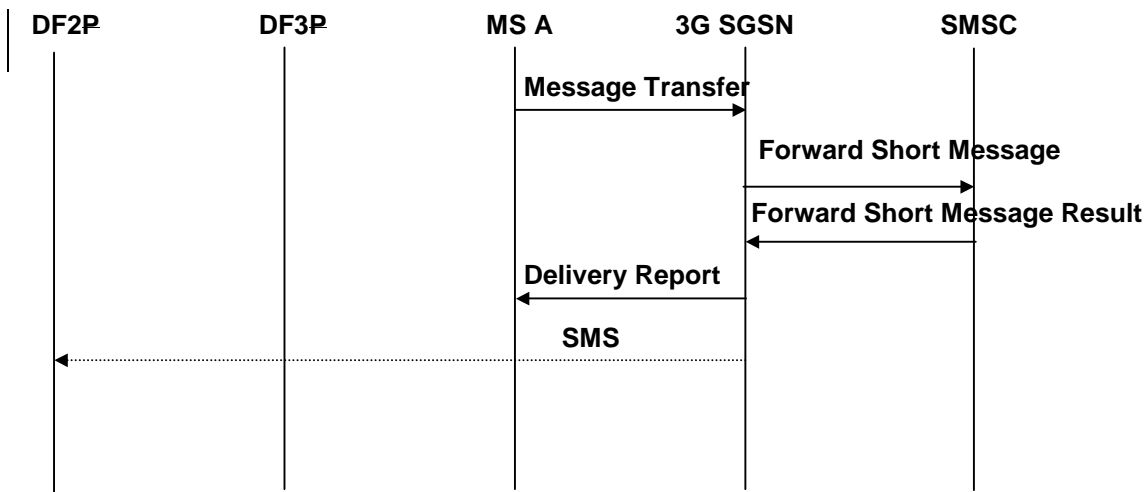

Figure B10: Interception of a Mobile-originated SMS transfer

## Annex C (multi-media call flows)

To be updated

1. Multi-media registration
2. Multi-media Session Establishment and Answer with visited network control
3. Multi-media release with visited network control
4. Multi-media call forwarding
5. Subscriber controlled input related to multi-media (via SIP)
6. Explicit call transfer

## Annex G (informative): Change history

Change history					
TSG SA #	Version	CR	Tdoc SA	New Version	Subject/Comment
S_03	1.0.0			3.0.0	Approved at SA#6 and placed under TSG SA Change Control