

**Source:** TSG SA WG2  
**Agenda item:** 7.2.3  
**Document for:** APPROVAL

### **Presentation of Specification to TSG or WG**

---

**Presentation to:** TSG SA Meeting #26  
**Document for presentation:** TS 23.979, Version 2.0.0  
**Presented for:** Approval

---

#### **Abstract of document:**

TR 23.979 describes the architectural requirements in order to enable services like PoC over 3GPP systems. The report looks into aspects of using 3GPP PS domain and radio access technologies (GERAN, UTRAN) for bearer services and IMS for reachability and connectivity for applications like PoC.

The TR 23.979 Version 2.0.0 is more than 80% completed and submitted for Approval

---

#### **Changes since last presentation to TSG SA Meeting #24:**

The TR 23.979 includes the following major changes since the last time it was presented for information:

- Cleanup of Session establishment (i.e. on-demand and pre-established) diagrams
- Annex A on QoS Settings and Configuration Parameters added
- Annex B on Delay analysis on PoC session establishment
- Annex C on Required SigComp performance added
- Conclusion section added to the TR 23.979 with the following statement included:
  - **[Quote from clause 6]** It is concluded that the current 3GPP IMS specifications supports the requirements to deploy PoC services as defined by OMA

---

#### **Outstanding Issues:**

None

---

#### **Contentious Issues:**

None

# 3GPP TR 23.979 V2.0.0 (2004-11)

---

*Technical Report*

**3rd Generation Partnership Project;  
Technical Specification Group Services and System Aspects;  
3GPP enablers for OMA PoC Services;  
Stage 2  
(Release 6)**



The present document has been developed within the 3<sup>rd</sup> Generation Partnership Project (3GPP™) and may be further elaborated for the purposes of 3GPP.

The present document has not been subject to any approval process by the 3GPP Organizational Partners and shall not be implemented. This Specification is provided for future development work within 3GPP only. The Organizational Partners accept no liability for any use of this Specification. Specifications and reports for implementation of the 3GPP™ system should be obtained via the 3GPP Organizational Partners' Publications Offices.

---

*Select keywords from list provided in specs database.*

Keywords

---

<keyword[, keyword]>

**3GPP**

Postal address

---

3GPP support office address

---

650 Route des Lucioles - Sophia Antipolis  
Valbonne - FRANCE  
Tel.: +33 4 92 94 42 00 Fax: +33 4 93 65 47 16

Internet

---

<http://www.3gpp.org>

---

**Copyright Notification**

---

No part may be reproduced except as authorized by written permission.  
The copyright and the foregoing restriction extend to reproduction in all media.

© 2003, 3GPP Organizational Partners (ARIB, CWTS, ETSI, T1, TTA, TTC).  
All rights reserved.

# Contents

Foreword.....	5
Introduction.....	5
1 Scope .....	6
2 References .....	6
3 Definitions, symbols and abbreviations.....	7
3.1 Definitions.....	7
3.2 Abbreviations .....	7
4 Architectural Requirements .....	7
4.1 General Requirements .....	7
4.2 PoC specific requirements relevant to 3GPP.....	8
5 Architectural Concept.....	8
5.1 General overview .....	8
5.2 Architecture assumptions .....	9
5.2.1 Charging architecture aspects.....	9
5.3 Signalling plane impacts .....	10
5.3.1 General aspects for PoC signalling.....	10
5.3.2 On-demand Session .....	10
5.3.2.1 On-demand session general .....	10
5.3.2.2 On-demand session with automatic answer.....	10
5.3.2.3 On demand session with manual answer .....	13
5.3.3 Pre-established Session.....	16
5.3.3.1 Pre-established session general.....	16
5.3.3.2 Pre-established session with automatic answer .....	16
5.3.3.3 Pre-established session with manual answer .....	18
5.4 User plane impacts .....	21
5.4.1 General .....	21
5.4.2 GPRS interactions in relation to PoC .....	21
5.4.2.1 General .....	21
5.4.2.2 QoS traffic class considerations.....	21
5.4.3 PoC and SBLP/Go functions .....	22
5.5 Notification of Parallel Services.....	22
5.5.1 Notification of incoming CS service during a PoC session.....	22
5.5.2 Notification of PoC Session during an ongoing CS Service.....	22
6 Conclusions .....	23
Annex A (informative): Recommended QoS settings and configuration parameters for PoC.....	24
A.1 Introduction .....	24
A.2 QoS attribute settings.....	24
A.2.1 QoS attribute settings for general purpose PDP context.....	24
A.2.2 QoS attribute settings when separate PDP contexts are used for signalling and media.....	25
A.3 Radio Network Configuration .....	27
Annex B (Informative): Delay analysis of PoC session establishment.....	28
B.1 Introduction.....	28
B.2 On demand session with manual answer.....	28
B.3 On demand session with automatic answer.....	30
B.4 On pre-established session .....	32
Annex C (Informative): Required SigComp performance.....	35
C.1 Introduction.....	35
C.2 Assumptions .....	35
C.3 Estimation of SIP compression ratios .....	35
C.4 SigComp requirements.....	36

**Annex D: Change history** ..... 37

---

## Foreword

This Technical Report has been produced by the 3<sup>rd</sup> Generation Partnership Project (3GPP).

The contents of the present document are subject to continuing work within the TSG and may change following formal TSG approval. Should the TSG modify the contents of the present document, it will be re-released by the TSG with an identifying change of release date and an increase in version number as follows:

Version x.y.z

where:

- x the first digit:
  - 1 presented to TSG for information;
  - 2 presented to TSG for approval;
  - 3 or greater indicates TSG approved document under change control.
- y the second digit is incremented for all changes of substance, i.e. technical enhancements, corrections, updates, etc.
- z the third digit is incremented when editorial only changes have been incorporated in the document.

---

## Introduction

Advanced interactive conferencing applications like Push to talk over Cellular (PoC) service enablers are being developed in OMA. It is expected that some enhancements of the 3GPP specifications will be needed in order to use IMS & its capabilities as a base for the PoC services.

---

## 1 Scope

The present document studies the architectural requirements in order to enable services like PoC over 3GPP systems. The report looks into aspects of using 3GPP PS domain and radio access technologies (GERAN, UTRAN) for bearer services and IMS for reachability and connectivity for applications like PoC.

---

## 2 References

The following documents contain provisions, which, through reference in this text, constitute provisions of the present document.

- References are either specific (identified by date of publication, edition number, version number, etc.) or non-specific.
- For a specific reference, subsequent revisions do not apply.
- For a non-specific reference, the latest version applies. In the case of a reference to a 3GPP document (including a GSM document), a non-specific reference implicitly refers to the latest version of that document *in the same Release as the present document*.

- [1] 3GPP TR 41.001: "GSM Release specifications".
- [2] 3GPP TS 21.905: "Vocabulary for 3GPP Specifications".
- [3] 3GPP TS 23.002: "Network architecture".
- [4] 3GPP TS 23.228: "IP Multimedia (IM) Subsystem - Stage 2".
- [5] 3GPP TS 23.141 "Presence Service; Stage 2"
- [6] OMA-AD-PoC-V1.0 (October 2004), OMA PoC Specification, AD.
- [7] OMA-RD-PoC-V1\_0 (June 2004), OMA PoC Specification, RD.
- [8] 3GPP TS 24.229: "IP Multimedia Call Control Protocol based on Session Initiation Protocol (SIP) and Session Description Protocol; Stage 3"
- [9] 3GPP TS 23.207: "End-to-end Quality of Service (QoS) concept and architecture"
- [10] 3GPP TS 23.107: "Quality of Service (QoS) concept and architecture"
- [11] 3GPP TS 26.071: "AMR speech Codec; General description"
- [12] RFC 3267 (June 2002): "Real-Time Transport Protocol (RTP) Payload Format and File Storage Format for the Adaptive Multi-Rate (AMR) and Adaptive Multi-Rate Wideband (AMR-WB) Audio Codecs".
- [13] 3GPP TS 23.221: "Architectural requirements"
- [14] RFC 3320 (January 2003): "Signaling Compression (SigComp)".
- [15] 3GPP TS 24.228 "Signalling flows for the IP multimedia call control based on Session Initiation Protocol (SIP) and Session Description Protocol (SDP); Stage 3"
- [16] 3GPP TS 24.229 "IP Multimedia Call Control Protocol based on Session Initiation Protocol (SIP) and Session Description Protocol (SDP); Stage 3"

---

## 3 Definitions, symbols and abbreviations

### 3.1 Definitions

For the purposes of the present document, the terms and definitions given in TS 21.905 [2] and the following apply.

**PoC session:** This is an established connection between PoC users where the users can communicate using voice one at a time.

**Right to Speak:** In the PoC session establishment, the originating subscriber receives within a pre-determined time, an indication before he can speak, this is known as “Right to Speak (RtS)”.

### 3.2 Abbreviations

For the purposes of the present document, the following abbreviations apply:

CSCF	Call Session Control Function
GLMS	Group and List Management Server
PoC	Push to talk over Cellular
I-CSCF	Interrogating-CSCF
IMS	IP Multimedia Subsystem
IP	Internet Protocol
P-CSCF	Proxy-CSCF
S-CSCF	Serving-CSCF
SBLP	Service Based Local Policy
UE	User Equipment

---

## 4 Architectural Requirements

### 4.1 General Requirements

The 3GPP system shall provide the capabilities to support the PoC service architecture as specified in OMA.

It is assumed that the PoC architecture makes use of the following IMS capabilities in the 3GPP system, which are described in TS 23.228 [4] and TS 23.141 [5]:

- Registration;
- IMS routing capabilities, including discovery and address resolution;
- IMS security including authentication and authorization;
- IMS charging;
- SIP compression;
- IMS group management;
- Public service identities;
- Presence Service.

Commonality and differences with IMS conferencing require further study.



## 4.2 PoC specific requirements relevant to 3GPP

In order for 3GPP system to support services like PoC, certain PoC requirements will require additional analysis within 3GPP in order to determine that all necessary architectural support is in place via capabilities provided by the GERAN/UTRAN, GPRS and IMS.

This section captures the possible relevant requirements for the purposes of additional evaluation to ensure proper support is in place within 3GPP infrastructure:

- The PoC service entity may provide the originating user with an early indication to start to speak even before invited users accept the call.
- If the above condition is applied then the initiating PoC subscriber shall receive an indication if no participants receive the talk burst.
- The originating subscriber receives 'right-to-speak' (RtS) indication after certain time depending on the answer mode setting of the target PoC subscriber.
- Depending on the setting by the PoC subscriber, the right-to-speak indication can be given to the originating PoC subscriber before the target PoC subscriber is reached or at least one of the target PoC subscribers has to accept the PoC session before the 'right-to-speak' indication is given to the originating PoC subscriber.
- During the PoC session, the PoC service entity provides 'right-to-speak' indication to a PoC subscriber requesting to speak.
- In case of a chat group session, the communication between chat group participants shall be possible at the time the PoC chat group session is established, that is at least one participant has joined the chat session.
- The timing requirements for capabilities such as RtS shall be taken into account within 3GPP as specified in OMA RD [6].
- Charging architecture requirements shall be taken into account as specified in OMA PoC AD.
- The user equipment, depending on its capabilities, shall support notification of incoming CS call during an ongoing PoC session as well as a notification of an incoming PoC session set up during an ongoing CS call.

---

## 5 Architectural Concept

### 5.1 General overview

PoC service is introduced as an application within the frame of the IP Multimedia Subsystem (IMS). Figure 5.1 below illustrates how the PoC service elements fit into the IMS architecture.

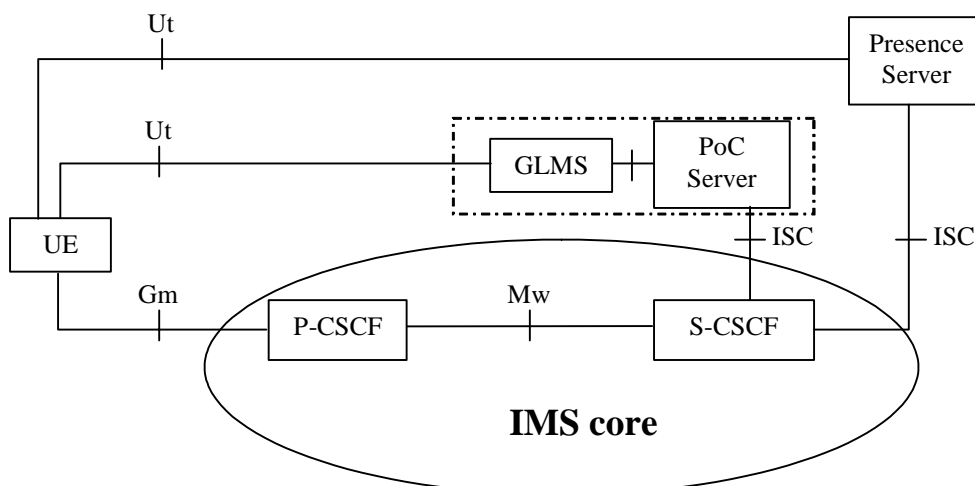

**Figure 5-1. PoC service elements in the IMS architecture**

Note: The I-CSCF is not shown in Figure 5-1 for the sake of simplicity.

The OMA PoC architecture specification [6] leverages IMS as the underlying SIP-based IP-core network. To understand the details of how IMS capabilities relate to the overall PoC architecture, there is a need to map the reference points defined in the OMA PoC specification [6], and the reference points defined in 3GPP TS 23.002 [3] and 3GPP TS 23.228 [4].

The PoC server implementing the application level network functionality for the PoC service is essentially seen as an Application Server from the IMS perspective. Consequently, communications between the IMS core and the PoC server utilize the ISC interface defined in 3GPP TS 23.228 [4].

As defined by [6], the Group and List Management Server (GLMS) is used by the PoC users to manage groups and lists (e.g. contact and access lists) that are needed for the PoC service. In the IMS architecture, the Ut interface provides these functions, hence communications between the GLMS and the UE utilize the Ut interface.

As defined by [6], a Presence Server may provide availability information about PoC users to other PoC users. The 3GPP Presence architecture and the Presence Server are defined in TS 23.141 [5].

## 5.2 Architecture assumptions

### 5.2.1 Charging architecture aspects

3GPP TS 32.240 specifies the overall charging architecture for the 3GPP system, including the IMS charging architecture. 3GPP TS 32.260 and 3GPP TS 32.299 specify the IMS charging details, including the S-CSCF's interfaces towards the charging nodes used for session charging.

Based on the IMS charging architecture described in these TSs, and the mapping of IMS and OMA PoC architectures described in Section 5.1, the architecture described in Figure 5-2 below shows the charging interfaces around the PoC server:

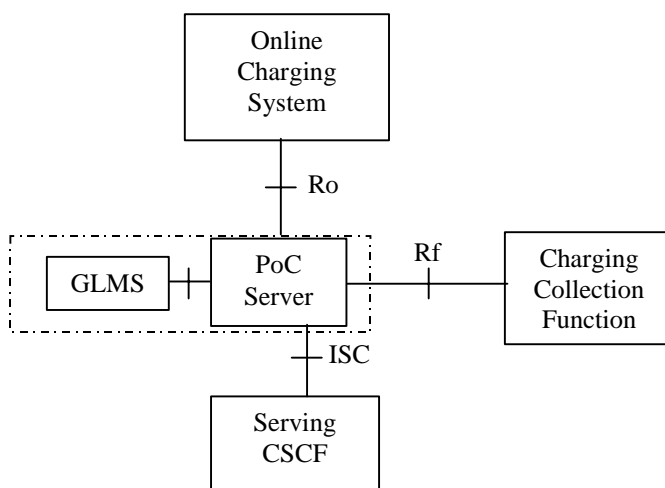
**Figure 5-2 - Architecture for PoC charging**

The Charging Collection Function (CCF) is used for offline charging. It shall be possible for the PoC server to send offline accounting information about PoC-service events to the CCF using the mechanisms described for the Rf interface described in 3GPP TS 32.260. Possible additional accounting information to cover PoC charging requirements shall be fulfilled by extending the Rf interface, if needed.

The address of the CCF to be used by the PoC server for the PoC session is distributed to the PoC server in SIP signaling, as described in 3GPP TS 24.229 [8].

The Online Charging System is used for online charging PoC service-related events. It shall be possible for the PoC server to perform credit control interactions as per the mechanisms defined for the Ro interface. The address of the OCS (same as the address of the ECF) to be used by the PoC server for the PoC session is distributed to the PoC server in SIP signaling.

## 5.3 Signalling plane impacts

### 5.3.1 General aspects for PoC signalling

As described in OMA-AD\_PoC [6] architecture document, there are two mechanisms for session establishment signalling supported. In both scenarios, the session is first established between the PoC user (originating or terminating) and the PoC server serving the user and then the other party is invited to the session. User preferences on how the handled PoC sessions may require special user level interactions are described in the OMA\_RD PoC [7] and OMA\_AD\_PoC [6], but the general principle of the session flows is not affected by such interactions.

The mechanisms for session set-up as defined by OMA are described in the following sub-clauses in more detail, i.e. those would require changes if changes are performed in the OMA specifications. These procedures have the following functional description of behaviour:

#### 1. On-Demand Session:

The On Demand session provides a mechanism to negotiate media parameters such as IP address, ports and codecs, which are used for sending the media and floor control packets between the PoC Client and the home PoC Server when the user wants to actually establish a PoC session. This mechanism allows the PoC Client to invite, via PoC server(s), other PoC clients or receive PoC sessions by using the full session establishment procedure each time the user wants to establish/receive/join a PoC session. Media parameters may be negotiated again in this mechanism.

#### 2. Pre-established Session:

The pre-established session provides a mechanism to negotiate media parameters such as IP address, ports and codecs, which are used for sending the media and floor control packets between the PoC Client and the home PoC Server before establishing the PoC session. This mechanism allows the PoC Client to invite other PoC clients or receive PoC sessions without negotiating again the media parameters. After the pre-established session has been set up (once the PoC user has registered), the PoC Client is able to activate media bearer whenever needed:

- immediately after the general PoC session pre-establishment procedure or;
- when the actual SIP signalling for the PoC media session establishment is initiated.

### 5.3.2 On-demand Session

#### 5.3.2.1 On-demand session general

For an on-demand PoC session set-up all media parameters are negotiated at the same time the PoC session is set-up. Two types of on-demand session set-up procedures are described below.

#### 5.3.2.2 On-demand session with automatic answer

A simplified PoC session flow for on-demand session with automatic answer is shown below when using GPRS bearer. The flow shows a general case and relation of PDP context with PoC/IMS session and does not show any special order or requirement of whether separate PDP context is required for the media or not.

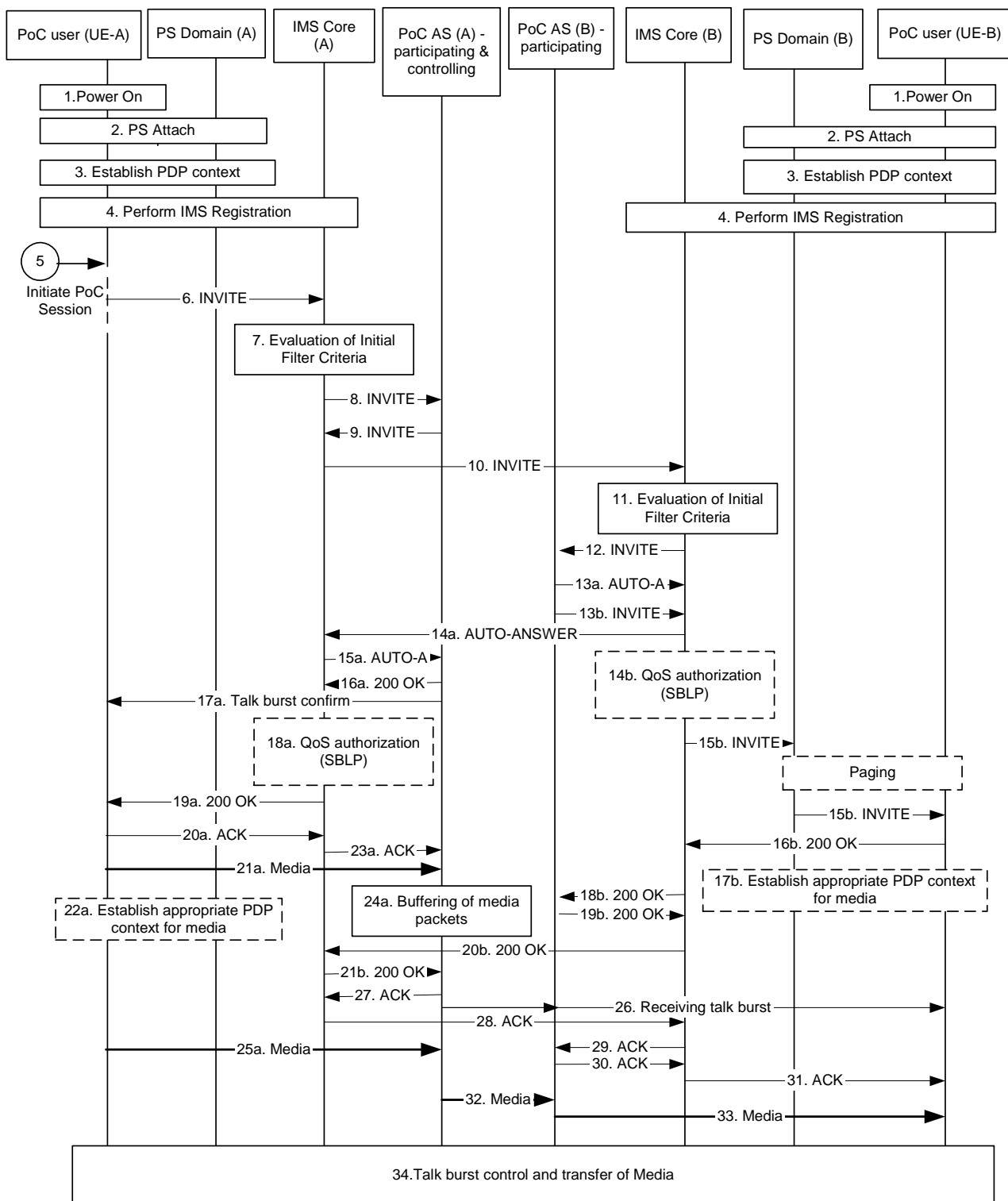

Figure 5.3.1 On-demand signalling with automatic answering

The simplified steps for establishing PoC communication based upon on demand signalling with auto answering are:

1. Each UE is powered on.
2. Each UE performs PS attach in order to register to the PS domain.
3. Each UE ensures that a PDP context suitable for IMS related signalling is established and if necessary an additional general-purpose PDP context with the same APN and IP address as the PDP context for IMS related signalling..

Note: This may occur at different times for each terminal. The use of the PDP context bearer(s) depends on how the terminal, network and overall system are configured to operate. Detailed implications of such scenarios will be further analysed in clause 5.4 and clause 6.

It is FFS whether the QoS of a pre-established PDP context for PoC talk burst control and media is allowed to have a higher QoS than best effort.

4. Each UE performs the IMS registration
  5. User A presses the push-to-talk indication/button on the terminal A to indicate that he wishes to communicate with the user at UE B.
- Note that step 5 can occur anytime after step 4 has been performed, there is no timing correlation between these steps once steps 1-4 has been performed.
6. UE-A creates a SIP session for the PoC communication by sending the INVITE request into the IMS Core (A), in this example with UE-B as a destination address (alternatively the destination address could also be a PSI hosted by a PoC server for a PoC group session). The INVITE request contains the PoC service indication and the SDP media parameters indicate the IP address obtained in step 3 and that UE-A is ready to send and receive media, as in this example the UE-A established a non real time PDP context for talk burst control and media at IMS registration time.
  - 7-8 The IMS core A identifies that the service indication matches ISC filtering information and routes the INVITE request to the PoC AS (A).
  - 9-107. PoC AS (A) (after determining that the PoC communication should be completed), together with the IMS Core (A), forwards the INVITE request towards the IMS Core (B).
  - 11-12. The IMS Core (B) identifies that the service indication matches ISC filtering information and routes the INVITE request to the PoC AS (B).
  - 13a. PoC AS (B) sends AUTO-ANSWER to PoC AS (A) as user B is accepting the session automatically
  - 13b. The PoC AS (B) forwards the INVITE request to UE-B via IMS Core (B)
  - 14a-15a. The IMS Core (B) forwards the AUTO-ANSWER message towards the PoC AS (A) via IMS Core (A)
  - 16a-17a. Based on the AUTO-ANSWER and that the PoC AS (A) supports buffering of media, the PoC AS (A) sends a 200 OK towards the UE-A and at the same time sends a talk burst confirm to UE-A. The talk burst control message is transferred to UE-A on a PDP contexts established in step 3.
  - 18a-19a. In case Service Based Local Policy is applied in UE A's network, IMS Core (A) generates an authorization token for the session, inserts and delivers the authorization token to the UE-A in the first available reliable SIP response (in this case the 200 OK).
  - 20a-22a. After the UE-A received both the 200 OK response and the talk burst confirm message, UE-A may send media data to PoC AS (A) using a PDP context established in step 3. The UE-A acknowledges the 200 OK. UE-A may establish an additional PDP context for media and talk burst control exchange with same IP address and APN as of the PDP contexts of step 3, e.g. a PDP context with traffic class streaming and bandwidth required for the negotiated media parameters. If the UE received an authorization token in step 19a, it inserts it in the PDP context signalling.
  - 23a. The IMS Core (A) forwards the acknowledgement to PoC AS (A)
  - 24a. The PoC AS (A) buffers the received media until a positive response from UE-B is received
  - 25a. UE-A continues sending media. If and when the PDP context established in step 22a is available, UE-A uses it.
  - 14b-15b. In case Service Based Local Policy is applied in UE B's network, IMS Core (B) generates an authorization token for the session, and inserts and delivers the authorization token in the INVITE request to UE-B.

Typically UE-B needs to be paged before the INVITE request can be transferred.

Note: The INVITE message is transparent to the PS Domain.

- 16b-17b After receiving the INVITE request, UE (B) accepts the session by returning 200 OK. The media parameters indicate the IP address obtained in step 3. UE B may establish an additional PDP context for media and talk burst control exchange with same IP address and APN as of the context of step 3, e.g. a PDP context with traffic class streaming and bandwidth required for the negotiated media parameters. If the UE received an authorization token in step 15b, it inserts it in the PDP context signalling.
- 18b-21b. IMS Core (B) forwards the 200 OK to the PoC AS (B), which forwards the 200 OK towards the PoC AS (A) via IMS Core (B) and IMS Core (A).
26. PoC AS (A) inform the UE-B via the PoC AS (B) that receiving talk bursts from UE-A are on the way.
- 27-29. The PoC AS (A) acknowledges the session set-up, the acknowledgement traverses to PoC AS (B) via IMS Core (A) and IMS Core (B).
- 30-31. The PoC AS (B) acknowledges the session set-up
32. The buffered media is transferred from PoC AS (A) to PoC AS (B).
33. PoC AS (B) transfer the media to UE-B. If and when the PDP context established in step 17b is available, it is used for this purpose
34. Further media and talk burst control messages are transferred between the involved entities.

### 5.3.2.3 On demand session with manual answer

A simplified PoC session flow for on-demand session with manual answer is shown below when using GPRS bearer. The flow shows a general case and relation of PDP context with PoC/IMS session and does not show any special order or requirement of whether separate PDP context is required for the media or not.

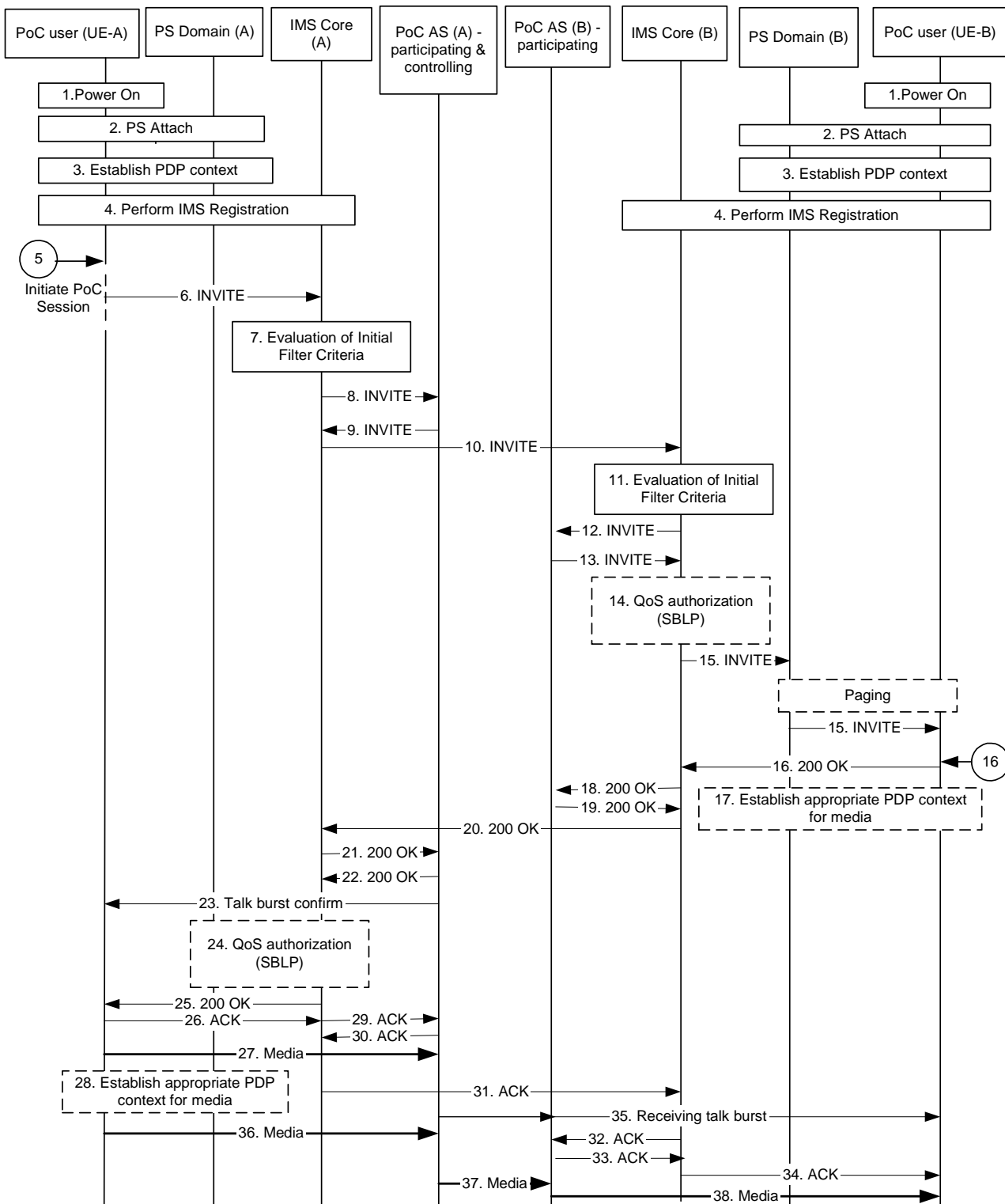

**Figure 5.3.2 On-demand signalling with manual answer**

The simplified steps for establishing PoC communication based upon on demand signalling with manual answering are:

1. Each UE is powered on.
2. Each UE performs PS attach in order to register to the PS domain.
3. Each UE ensures that a PDP context suitable for IMS related signalling is established and if necessary an additional general purpose PDP context with the same APN and IP address as the PDP context for IMS related signalling.

Note: This may occur at different times for each terminal. The use of the PDP context bearer(s) depends on how the terminal, network and overall system are configured to operate. Detailed implications of such scenarios will be further analysed in subclause 5.4 and clause 6.

It is FFS whether the QoS of a pre-established PDP context for PoC talk burst control and media is allowed to have a higher QoS than best effort.

4. Each UE performs the IMS registration
5. User A presses the push-to-talk indication/button on the UE A to indicate that he wishes to communicate with the user at UE B.

Note that step 5 can occur anytime after step 4 has been performed, there is no timing correlation between these steps once steps 1-4 has been performed.

6. UE-A creates a SIP session for the PoC communication by sending the INVITE request into the IMS Core (A), in this example with UE-B as a destination address (alternatively the destination address could also be a PSI hosted by a PoC server for a PoC group session). The INVITE request contains the PoC service indication and the SDP media parameters indicate the IP address obtained in step 3 and that UE-A is ready to send and receive media, as in this example the UE-A established a non real time PDP context for talk burst control and media at IMS registration time.
- 7-8. The IMS Core (A) identifies that the service indication matches ISC filtering information and routes the INVITE request to the PoC AS (A).
- 9-10. PoC AS (A) (after determining that the PoC communication should be completed), together with the IMS Core (A), forwards the INVITE request towards the IMS Core (B).
- 11-12. The IMS Core (B) identifies that the service indication matches ISC filtering information and routes the INVITE request to the PoC AS (B).
13. The PoC AS (B) forwards the INVITE request to UE-B via IMS Core (B)
- 14-15. In case Service Based Local Policy is applied in UE B's network, IMS Core (B) generates an authorization token for the session, and inserts and delivers the authorization token in the INVITE request to UE-B.

Typically UE-B needs to be paged before the INVITE request can be transferred.

Note: The INVITE message is transparent to the PS domain.

- 16-17. After receiving the INVITE request, user (B) accepts the session set-up manually and UE-B accepts the session by returning 200 OK. UE-B should send a 180 ringing response when receiving the INVITE request to avoid the INVITE request to be re-sent (not shown in the figure). The media parameters indicate the IP address obtained in step 3. UE B may establish an additional PDP context for media and talk burst control exchange with same IP address and APN as of the context of step 3, e.g. a PDP context with traffic class streaming and bandwidth required for the negotiated media parameters. If the UE-B received an authorization token in step 15, it inserts it in the PDP context signalling.
- 18-21. IMS Core (B) forwards the 200 OK to the PoC AS (B), which forwards the 200 OK towards the PoC AS (A) via IMS Core (B) and IMS Core (A).
- 22-23. PoC AS (A) sends a 200 OK towards the UE-A and at the same time sends a talk burst confirm to UE-A.
- 24-25. In case Service Based Local Policy is applied in UE A's network, IMS Core (A) generates an authorization token for the session, inserts and delivers the authorization token to the UE-A in the first available reliable SIP response (in this case the 200 OK).
- 26-28. After the UE-A received both the 200 OK response and the talk burst confirm message, UE-A may send media data to PoC AS (A) using a PDP context established in step 3. The UE-A acknowledges the 200 OK. UE-A may establish an additional PDP context for media and talk burst control exchange with same IP address and APN as of the PDP contexts of step 3, e.g. a PDP context with traffic class streaming and bandwidth required for the negotiated media parameters. If the UE received an authorization token in step 25, it inserts it in the PDP context signalling.



29. The IMS Core (A) forwards the acknowledgement to PoC AS (A)
- 30-32. The PoC AS (A) acknowledges the session set-up, the acknowledgement traverses to PoC AS (B) via IMS Core (A) and IMS Core (B).
- 33-34. The PoC AS (B) acknowledges the session set-up
35. PoC AS (A) inform the UE-B via the PoC AS (B) that receiving talk bursts from UE-A are on the way.
36. UE-A continues sending media. If and when the PDP context established in step 28 is available, UE-A uses it.
- 37-38. PoC AS (A) transfer the media to UE-B, via PoC AS (B). If and when the PDP context established in step 17 is available, it is used for this purpose

### 5.3.3 Pre-established Session

#### 5.3.3.1 Pre-established session general

For a pre-established PoC session, media parameters are negotiated at the setup of the pre-established PoC session and during the PoC session is setup the media parameter negotiation can be skipped. Two types of pre-established session set-up procedures are described below.

#### 5.3.3.2 Pre-established session with automatic answer

A simplified PoC session flow for the setup of session having pre-established session with automatic answer is shown below when using GPRS bearer. The flow shows a general case and relation of PDP context with PoC/IMS session and does not show any special order or requirement of whether separate PDP context is required for the media or not. This flow assumes (though it is not required for both sides to use the same mechanism) that both originating and terminating PoC user uses the Pre-established session mechanism.

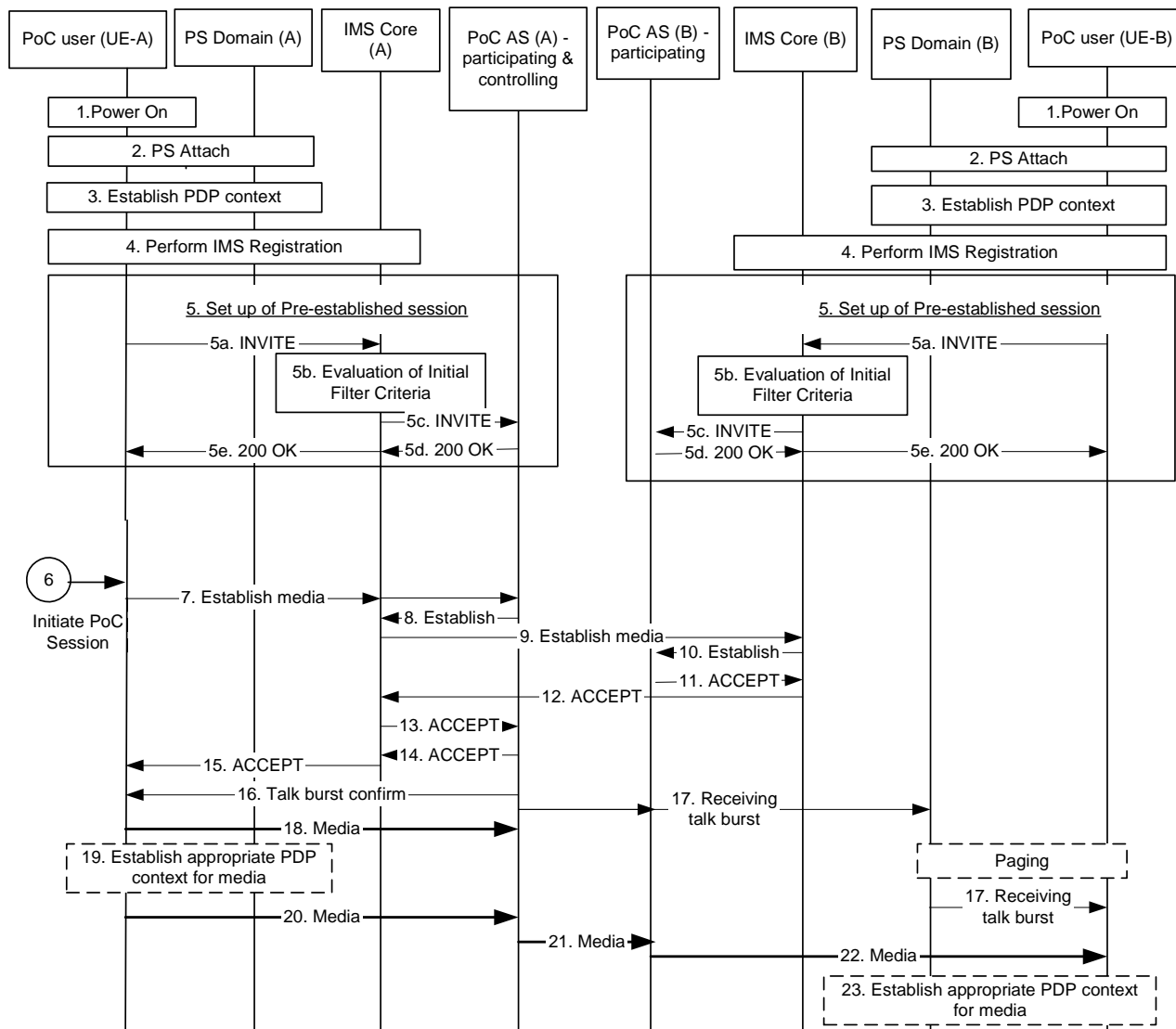

**Figure 5.3.3 Pre-established session signalling with automatic answering**

The simplified steps for establishing PoC communication based upon pre-established session signalling are:

1. Each terminal is powered on.
2. Each terminal performs PS attach in order to authenticate to the PS domain.
3. Each UE ensures that a PDP context suitable for IMS related signalling is established and if necessary an additional general purpose PDP context with the same APN and IP address as the PDP context for IMS related signalling.  
 Note: This may occur at different times for each terminal. The use of the PDP context bearer(s) depends on how the terminal, network and overall system are configured to operate. Detailed implications of such scenarios will be further analysed in subclause 5.4 and clause 6.
4. Each terminal performs the IMS registration
5. Each terminal establishes the pre-established session for PoC communication towards the PoC AS (e.g. by using a dedicated PSI). The INVITE request contains the PoC service indication and the SDP media parameters indicate the IP address obtained in step 3; the IMS Core (A) identifies that this service indication matches ISC filtering information and routes the session establishment request to the PoC AS (A).

In case Service Based Local Policy is applied in the UE(A)'s IMS network, IMS Core (A) generates an authorization token for the session, inserts and delivers the authorization token to the UE-A upon set-up of the pre-established session (in the 200OK response).

Note: This pre-established session set-up may occur at different times for each terminal. Once the session relationship is established, it remains as long as the user wishes to remain connected to the PoC server. Implications of such long established session and its relationship with other IMS functions will require further study.

6. User A presses the push-to-talk indication/button on the terminal A to indicate that he wishes to communicate to the user at UE (B).
- 7-10. UE-A request the establishment of media transfer and sends, for example, a SIP REFER message to the PoC AS (A) via the IMS Core (A), containing the address of the terminating user. PoC AS (A) sends the message to PoC AS (B) by means of IMS core (A) and IMS Core (B).
- 11-13. PoC AS (B) accepts the session initiation to PoC AS (A), via IMS Core (B) and IMS Core (A).
- 14-16. The PoC AS (A) acknowledges the media establishment request message and at the same time sends a talk burst confirm to UE-A. The talk burst control message is transferred to UE-A on a PDP contexts established in step 3.
17. PoC AS (A) inform the UE-B via the PoC AS (B) that receiving talk bursts from UE-A are on the way.

Typically UE-B needs to be paged before the Receiving talk burst message can be transferred

Note: The Receiving talk burst message is transparent to the PS Domain.

- 18-19. After the UE-A received both the acknowledgement for the media establishment request message and the talk burst confirm message, UE-A may send media data to PoC AS (A). UE-A may establish an additional PDP context for media and talk burst control exchange with same IP address and APN as of the PDP contexts of step 3, e.g. a PDP context with traffic class streaming and bandwidth required for the negotiated media parameters. If the UE received an authorization token in step 5, it inserts it in the PDP context signalling. As soon as the PDP context established in step 18 is available, UE-A uses it.
- 20-22. UE-A continues sending media. If and when the PDP context established in step 19 is available, UE-A uses it. UE-A sends the media data to PoC AS (A), which sends media data to UE-B, via PoC AS (B).
23. Having received the receiving talk burst message, UE-B may establish an additional PDP context for media and talk burst control exchange with same IP address and APN as of the context(s) of step 3, e.g. a PDP context with traffic class streaming and bandwidth required for the negotiated media parameters. If the UE received an authorization token in step 5, it inserts it in the PDP context signalling.

### 5.3.3.3 Pre-established session with manual answer

A simplified PoC session flow for the setup of session having pre-established session with manual answer is shown below when using GPRS bearer. The flow shows a general case and relation of PDP context with PoC/IMS session and does not show any special order or requirement of whether separate PDP context is required for the media or not. This flow assumes (though it is not required for both sides to use the same mechanism) that both originating and terminating PoC user uses the Pre-established session mechanism.

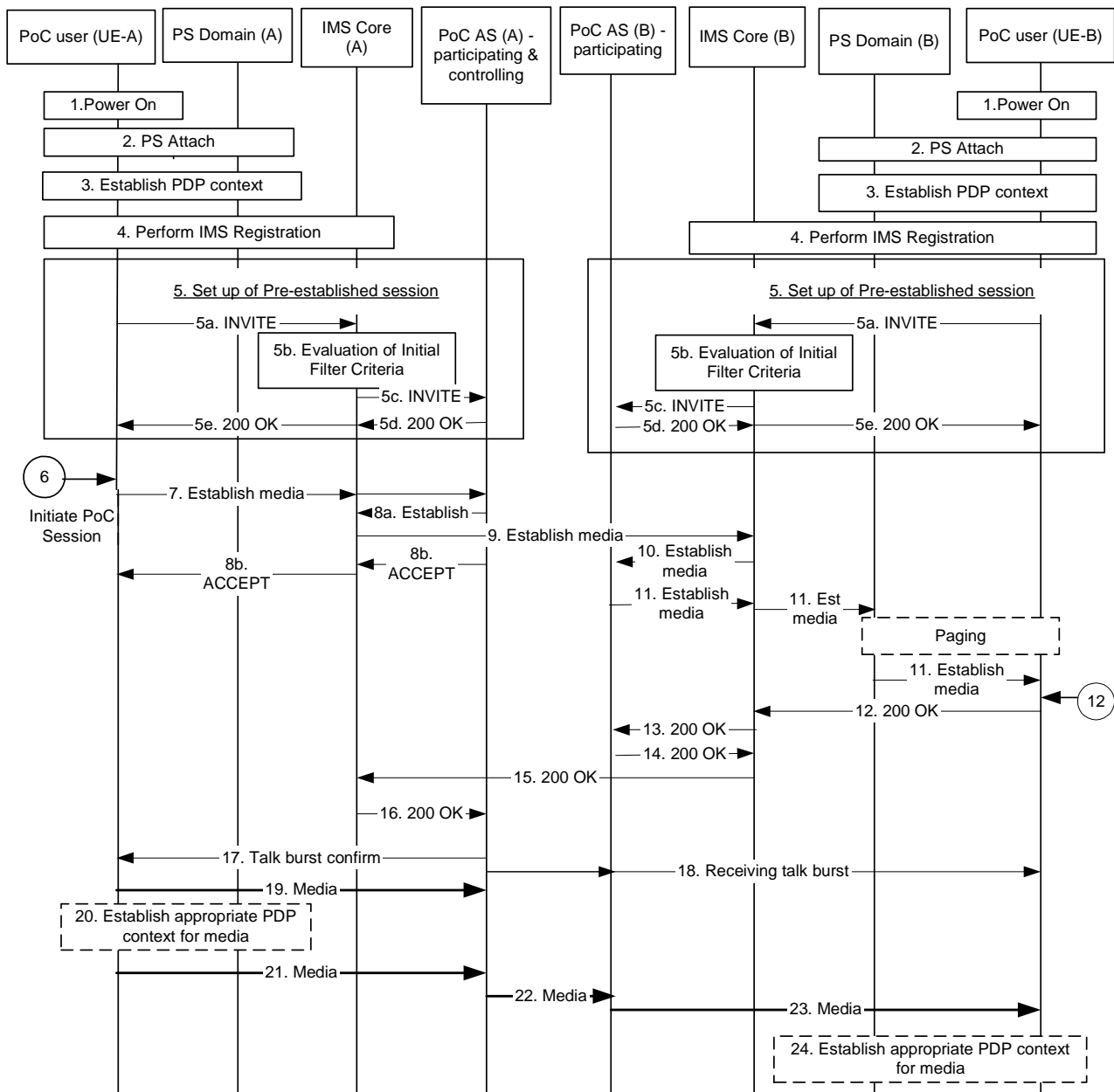

Figure 5.3.4 Pre-established session handling with manual answer

The simplified steps for establishing PoC communication based upon pre-established session signalling are:

1. Each terminal is powered on.
2. Each terminal performs PS attach in order to authenticate to the PS domain.
3. Each UE ensures that a PDP context suitable for IMS related signalling is established and if necessary an additional general purpose PDP context with the same APN and IP address as the PDP context for IMS related signalling.  
 Note: This may occur at different times for each terminal. The use of the PDP context bearer(s) depends on how the terminal, network and overall system are configured to operate. Detailed implications of such scenarios will be further analysed in subclause 5.4 and clause 6.
4. It is FFS whether the QoS of a pre-established PDP context for PoC talk burst control and media is allowed to have a higher QoS than best effort
4. Each terminal performs the IMS registration

5. Each terminal establishes the pre-established session for PoC communication towards the PoC AS (e.g. by using a dedicated PSI). The INVITE request contains the PoC service indication and the SDP media parameters indicate the IP address obtained in step 3; the IMS Core (A) identifies that this service indication matches ISC filtering information and routes the session establishment request to the PoC AS (A).

In case Service Based Local Policy is applied in the UE(A)'s IMS network, IMS Core (A) generates an authorization token for the session, inserts and delivers the authorization token to the UE-A upon set-up of the pre-established session (in the 200OK response).

Note: This pre-established session set-up may occur at different times for each terminal. Once the session relationship is established, it remains as long as the user wishes to remain connected to the PoC server. Implications of such long established session and its relationship with other IMS functions will require further study.

6. User A presses the push-to-talk indication/button on the terminal A to indicate that he wishes to communicate to the user at UE (B).
7. UE-A requests the establishment of media transfer and sends, for example, a SIP REFER message to the PoC AS (A) via the IMS Core (A), containing the address of the terminating user.
- 8a-10. PoC AS (A) sends the INVITE message to PoC AS (B) by means of IMS core (A) and IMS Core (B).
- 8b. PoC AS (A) sends ACCEPT message to UE-A via IMS core (A).
11. The PoC AS (B) requests the establishment of media transfer and sends, for example, a SIP re-INVITE message to the UE (B) via the IMS Core (B).

Typically UE-B needs to be paged before the SIP re-INVITE message can be transferred.

Note: The re-INVITE message is transparent to the PS Domain

12. After receiving the re-INVITE request, user (B) accepts the session set-up manually and UE-B accepts the session by returning 200 OK. UE-B should send a 180 ringing response when receiving the INVITE request to avoid the re-INVITE request to be re-sent (not shown in the figure). The media parameters indicate the IP address obtained in step 3.
- 13-16. IMS Core (B) forwards the 200 OK to the PoC AS (B), which forwards the 200 OK towards the PoC AS (A) via IMS Core (B) and IMS Core (A).
17. The PoC AS (A) sends a talk burst confirm to UE-A. The talk burst control message is transferred to UE-A on a PDP contexts established in step 3.
18. PoC AS (A) informs the UE-B via the PoC AS (B) that receiving talk bursts from UE-A are on the way.
- 19-20. After the UE-A received both the acknowledgement for the media establishment request message and the talk burst confirm message, UE-A may send media data to PoC AS (A). UE-A may establish an additional PDP context for media and talk burst control exchange with same IP address and APN as of the PDP contexts of step 3, e.g. a PDP context with traffic class streaming and bandwidth required for the negotiated media parameters. If the UE received an authorization token in step 5, it inserts it in the PDP context signalling. As soon as the PDP context established in step 20 is available, UE-A uses it.
- 21-23. UE-A continues sending media. If and when the PDP context established in step 20 is available, UE-A uses it. UE-A sends the media data to PoC AS (A), which sends media data to UE-B, via PoC AS (B).
24. Having received the receiving talk burst message, UE-B may establish an additional PDP context for media and talk burst control exchange with same IP address and APN as of the context(s) of step 3, e.g. a PDP context with traffic class streaming and bandwidth required for the negotiated media parameters. If the UE received an authorization token in step 5, it inserts it in the PDP context signalling.

## 5.4 User plane impacts

### 5.4.1 General

The deployment of PoC services over IMS requires some analysis regarding the general IMS as well as the radio, GPRS and terminals. The available QoS and use of specific QoS, codecs etc. may also require analysis or require some guidelines to be provided by 3GPP towards PoC service deployment.

This section provides the background material from which the architecture analysis work can draw the necessary conclusions to be captured in section 6.

### 5.4.2 GPRS interactions in relation to PoC

#### 5.4.2.1 General

It is assumed that additional PDP contexts (within a single APN) to separate signalling and media traffic within IMS is required only when:

- the QoS need to be different for signalling and media traffic,
- and/or restricted handling of the signalling traffic is required (due to charging (if FBC is not used), policy, policing etc.),
- and/or restricted handling of media traffic is required (due to charging, Service Based Local Policy, policing etc.),
- and/or other GPRS traffic can not use the same PDP context as IMS/PoC.

It is assumed that any of the following are valid GPRS/PDP contexts usage option for any IMS service, i.e. the options also apply for PoC. However, it is not only up to the PoC client to chose any of the options below as the valid options depends on possible restrictions, e.g. whether the GGSN apply restrictions on the PDP context used for IMS signalling as specified in 3GPP TS 23.228[4].

1. A Single PDP context is used for both IMS signalling and media traffic.
2. A separate PDP context for media traffic is required, but IMS signalling may share a general purpose PDP context with other GPRS traffic,
3. A separate PDP context is required for IMS signalling traffic, but the media traffic can share a PDP context with other general purpose PDP Context such as IMS session based messaging as described in 23.228[4],
4. Separate PDP contexts required for IMS signalling, all media share a single PDP context and other GPRS traffic use separate PDP context,
5. Separate PDP contexts required for IMS signalling, all media such as audio, text etc require separate PDP context and other GPRS traffic use separate PDP context,

How such combinations interact with PoC session establishment mechanism need further analysis. Depending on the mechanism used (on-demand and pre-established), whether existing PDP context can be reused or not, how floor control messages should be treated (as user plane traffic or signalling traffic or both) and whether SBLP/Go function is in use or not, the sessions flows may need to be further verified.

#### 5.4.2.2 QoS traffic class considerations

OMA POC AD [6] recommends that when different PDP contexts are used for IMS signalling and media traffic the OMA PoC Clients should separately utilize the QoS traffic class that is best suitable for signalling (e.g., Interactive traffic class) and the QoS traffic class that is best suitable for the media traffic (e.g. Streaming or Conversational traffic classes).

NOTE: The definitions of the QoS traffic classes used are described in TS 23.107 [10].

According to the OMA POC AD [6], when a single PDP context is used for both IMS Signaling and media traffic the PoC Client should utilize the QoS traffic class that is determined to be the best available considering the overall needs of the PoC Service (e.g., Interactive traffic class).

Recommended QoS settings and radio network configurations for PoC are presented in Annex A.

### 5.4.3 PoC and SBLP/Go functions

The signaling procedures being studied within OMA for PoC communication are optimized for session establishment time. Therefore they do not assume that SIP preconditions are used for PoC. However, if SBLP and the Go interface are deployed, they can be used as illustrated in the flows in subclause 5.3 as a use-case of the flows in subclause 5.7a of TS 23.228 [4].

For more information on SBLP/Go functions, see 3GPP TS 23.228 [4] and 3GPP TS 23.207 [9].

## 5.5. Notification of Parallel Services

### 5.5.1 Notification of incoming CS service during a PoC session

PoC is provided as a service in the PS domain. This implies that the existing mechanisms are used for paging and notification of an incoming CS service during a PoC session.

This means:

- For a UE in class A mode of operation and Dual Transfer Mode of operation, the CS paging during PS bearer will be applied as defined for UTRAN or class A/B or DTM GERAN.
- For a UE in class B mode of operation, CS paging during PS bearer will be applied as defined for UTRAN or class A/B or DTM GERAN. If the user accepts the CS service, the PS bearer may be suspended or dropped and as a result any PoC session is put on hold or terminated respectively.
- UE in class C mode of operation does not support multiple services, thus the issue does not exist.

### 5.5.2 Notification of PoC Session during an ongoing CS Service.

PoC is provided as a service in the PS domain. This implies that notification of an incoming PoC sessions during an ongoing CS Service is possible as follows:

- For UE in Class A mode of operation and Dual Transfer Mode of operation, it is possible to send the initial PoC notification (e.g. the INVITE) to the UE during an ongoing CS Service.
- For UE in Class B mode of operation does not need to monitor GERAN control channels during CS services. CS services have higher priority than PS services. Thus incoming PoC session requests cannot be delivered to the UE during an ongoing CS call.
- UE in class C mode of operation does not support multiple services, thus the issue does not exist.

---

## 6 Conclusions

The TR describes the architectural requirements to support the OMA PoC services in clause 4 and the impacts to the architectural concepts in clause 5. This Clause 5 addresses the impacts to the signalling plane by describing the on-demand and pre-established sessions. Also the impacts to the User Plane are described as well.

The concept of Service Based Local Policies (SBLP) and the Go interface as described in 3GPP TS 23.228 [4] and 3GPP TS 23.207 [9] supports the OMA PoC signalling requirements for session establishment, however it is not mandated that these capabilities are to be used for the OMA PoC session establishment.

PoC will contain the same GPRS/PDP contexts usage options as for any IMS service, i.e. the options also apply for PoC. However, it is not only up to the PoC client to choose any of the GPRS/PDP contexts usage options as the valid options depends on possible restrictions, e.g. whether the GGSN apply restrictions on the PDP context used for IMS signaling as specified in 3GPP TS 23.228[4].

Annex A describes the recommended QoS Attribute settings and the Radio Network Configurations to support OMA PoC services.

The main issue in supporting PoC services is the session establishment delays. Annex B contains the analysis of the delay for the PoC session establishments based on 'on demand' signalling and based on 'pre-established session' signalling

Annex C describes the analyses of the required SigComp performance and gives requirements to support the PoC service. This analysis concludes that IMS provides sufficient SigComp support for the OMA PoC delay requirements

The PoC codecs are specified within 3GPP SA4.

It is concluded that the current 3GPP IMS specifications supports the requirements to deploy PoC services as defined by OMA



## Annex A (informative): Recommended QoS settings and configuration parameters for PoC

### A.1 Introduction

The Push-to-Talk over Cellular (PoC) application is to be run over PS Domain bearers. The application is characterized by half-duplex voice communication.

The Annex makes recommendations on QoS attribute settings and radio network configurations.

### A.2 QoS attribute settings

The following Sub-sections describe recommended QoS settings by the UE during PDP context activation and modification procedures for the media flow in PoC with only one general purpose PDP context (subclause A.2.1) and when separate PDP contexts are used for the media and signalling (subclause A.2.2).

The bandwidth needed for the media flow in PoC is to a large extent dependent on the negotiated speech codec bit rate together with the transport format. In the following it is assumed that AMR speech coding, TS 26.071 [11], together with the RTP payload format for AMR, RFC 3267 [12], is used in the 'octet-aligned mode', without interleaving and without CRCs. It is furthermore assumed that one RTP packet carries ten (10) AMR frames, corresponding to 10\*20 ms of speech (ptime=200). Note that also other packetization schemes are possible. Table A.2-1 shows the required bandwidth for the RTP flow on 'IP level' (i.e. including RTP/UDP/IP overhead) for the different AMR modes:

**Table A.2-1 Required bandwidth Uplink/Downlink for the RTP traffic for different AMR modes (ptime=200)**

AMR Mode	Required bandwidth when IPv4 is used [bits/s] [Note]	Required bandwidth when IPv6 is used [bits/s]
AMR 4.75	6840	7640
AMR 5.15	7240	8040
AMR 5.9	8040	8840
AMR 6.7	8840	9640
AMR 7.4	9640	10440
AMR 7.95	10040	10840
AMR 10.2	12440	13240
AMR 12.2	14440	15240
Note:	For the usage of IP version in IMS see TS 23.221 [13], subclause 5.1.	

#### A.2.1 QoS attribute settings for general purpose PDP context

If one general purpose PDP context is used for both media and signalling, the PDP context should be of traffic class Interactive.

The following QoS parameter values for such PDP context are recommended to be requested by the UE.

**Table A.2.1-1: Recommended QoS attribute settings for a single general purpose PDP Context for both the PoC control plane and user plane traffic**

Traffic class	Interactive class	Notes
Maximum bitrate (kbps)	See 'Notes'	The value for this parameter is based on the highest speech codec rate negotiated via SDP in the codec mode-set (see Table A.2-1) plus appropriate bandwidth for the SIP Signaling traffic to QoS limit the impact on the media flow.
Delivery order	No	In sequence delivery of voice samples is not required nor is it desirable since it creates jitter in the media channel. An RTP jitter buffer in the client should re-order packets if needed.
Maximum SDU size (octets)	1500	Maximum size of IP packets. No PoC specific setting needed.
SDU format information	-	Not applicable for traffic class Interactive.
Delivery of erroneous SDUs	No	It is sufficient to signal erroneous IP packets to the UE.
Residual BER	$10^{-5}$	Reflects the desire to have a medium level of protection to achieve an acceptable compromise between packet loss rate and voice transport delay and delay variation.
SDU error ratio	$10^{-4}$	See "Residual BER" parameter.
Transfer delay (ms)	-	Is not used for the Interactive traffic class.
Guaranteed bit rate (kbps)	-	Is not used for the Interactive traffic class.
Traffic handling priority	1	Specifies the relative importance for handling of all SDUs belonging to the radio access bearer compared to the SDUs of other bearers. Highest importance is recommended for PoC.
Source statistic descriptor	-	Not applicable for traffic class Interactive.
Signalling indication	No	The PDP context is not used for signalling only

## A.2.2 QoS attribute settings when separate PDP contexts are used for signalling and media

If separate PDP contexts are used for media and signalling, the PDP context for signalling should be of traffic class Interactive.

The following QoS parameter values for the PDP context are recommended to be requested by the UE for signalling.

**Table A.2.2-1: Recommended QoS attribute settings for a PDP Context used for the PoC control plane traffic**

Traffic class	Interactive class	Notes
Maximum bitrate (kbps)	8	For an Interactive PDP context solely used for signalling, the maximum bit rate should be 8 kbps
Delivery order	No	In sequence delivery of voice samples is not required nor is it desirable since it creates jitter in the media channel. An RTP jitter buffer in the client should re-order packets if needed.
Maximum SDU size (octets)	1500	Maximum size of IP packets. No PoC specific setting needed.
SDU format information	-	Not applicable for traffic class Interactive.
Delivery of erroneous SDUs	No	It is sufficient to signal erroneous IP packets to the UE.
Residual BER	$10^{-5}$	Reflects the desire to have a medium level of protection to achieve an acceptable compromise between packet loss rate and voice transport delay and delay variation.
SDU error ratio	$10^{-4}$	See "Residual BER" parameter.
Transfer delay (ms)	-	Is not used for the Interactive traffic class.
Guaranteed bit rate (kbps)	-	Is not used for the Interactive traffic class.
Traffic handling priority	1	Specifies the relative importance for handling of all SDUs belonging to the radio access bearer compared to the SDUs of other bearers. Highest importance is recommended for PoC.
Source statistic descriptor	-	Not applicable for traffic class Interactive.
Signalling indication	Yes/No	If set to Yes the operator may require the IMS signalling flag (in the PCO IE) to be set, in that case an additional PDP context to be able to receive early media and talk burst control messages may need to be established.

If the underlying access network supports the traffic class streaming and a separate PDP context is used for the media, the additional PDP context to be used for the media (voice) flows of the PoC application is recommended to be of streaming traffic class.

The following QoS attribute values for such PDP context are recommended to be requested by the UE.

**Table A.2.2-2: Recommended QoS attribute settings for PDP Contexts for the PoC user plane traffic.**

Traffic class	Streaming class	Notes
Maximum bitrate (kbps)	See 'Notes'	Should be set >= "Guaranteed bit rate".
Delivery order	No	In sequence delivery of voice samples is not required nor is it desirable since it creates jitter in the media channel. An RTP jitter buffer in the client should re-order packets if needed.
Maximum SDU size (octets)	1500	Maximum size of IP packets. No PoC specific setting needed.
SDU format information	-	Used in RAB QoS attributes only. Transparent RLC protocol mode is not suggested.
Delivery of erroneous SDUs	No	It is sufficient to signal erroneous IP packets to the UE.
Residual BER	$10^{-5}$	Reflects the desire to have a medium level of protection to achieve an acceptable compromise between packet loss rate and voice transport delay and delay variation.
SDU error ratio	$10^{-4}$	See "Residual BER" parameter.
Transfer delay (ms)	650	
Guaranteed bit rate (kbps)	See 'Notes'	The value for this parameter is based on the highest speech codec rate negotiated via SDP in the codec mode-set. See Table A.2-1.
Traffic handling priority	-	Is not used for the Streaming traffic class.
Source statistic descriptor	"Unknown"	Proposed setting is "unknown". "Speech" is to be used when the media stream has speech statistical behaviour only..
Signalling indication	-	Only applicable for Interactive class

### A.3 Radio Network Configuration

In addition to QoS, the following configuration means are available to improve the performance of the PoC service:

- UDP/IP header compression (RFC2507) or RTP/UDP/IP header compression (RFC3095) can be configured to reduce the required radio link capacity.
- Delayed release of DL Temporary Block Flows (TBFs) and Extended TBF Mode in UL (introduced in 3GPP Release 4, available for GERAN only) can be configured to preserve the TBF over a longer period of time

---

## Annex B (Informative): Delay analysis of PoC session establishment

### B.1 Introduction

This annex contains the analysis of the delay for the PoC session establishments based on ‘on demand’ signalling and based on ‘pre-established session’ signalling

The session establishment delay can be defined the time delay from the time when a user initiates a PoC session until the user can start to speak after receiving RtS (Talk burst confirm).

It is assumed that the UTRAN access is used and that the UE is in the UE idle mode.

### B.2 On demand session with manual answer

Figure B.1 shows the delay components for the case of the session establishment based on ‘on demand session with manual answer’ signalling.

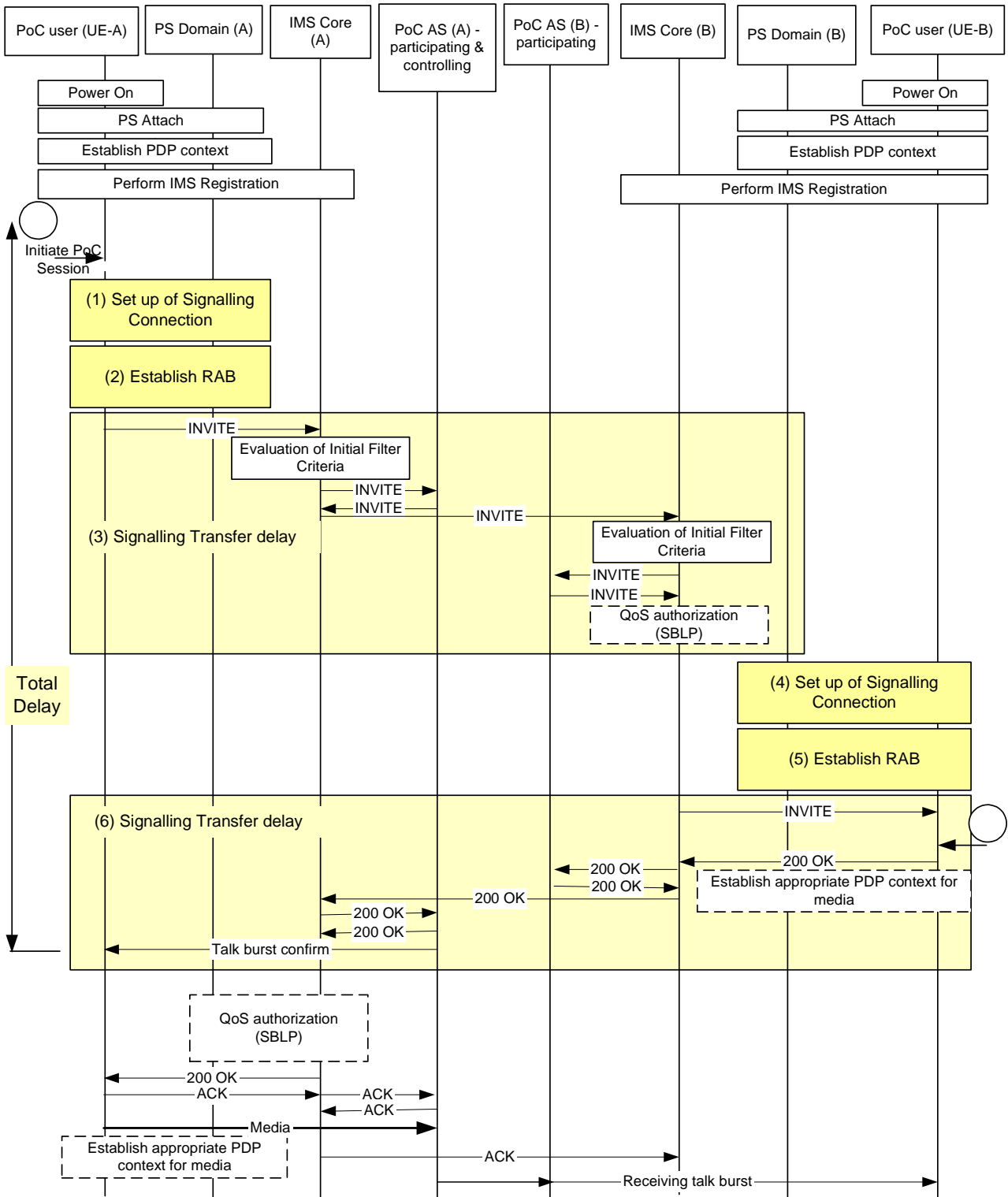

**Figure B.1 Delay component for the case of on demand session with manual answer**

(1) Set up of Signalling Connection in the UE-A side

When the User-A initiates a PoC Session, the UE-A shall establish the signalling connection to send the NAS signalling. This includes the RRC Connection Setup procedure, the Service Request procedure and the Security Mode Command procedure.

The major delay comes from the RRC connection setup procedure, which includes the Random Access procedure, the RL setup procedure and the RB setup procedure.

→ The estimated delay is about [700ms~1500ms].

(2) Establish Radio Access Bearer (RAB) in the UE-A side

RAB should be established for the existing PDP context through which the SIP INVITE message is transmitted by the UE-A. This includes the RAB assignment procedure and the Radio Link (RL) reconfiguration procedure and the Radio Bearer (RB) setup procedure.

→ *The estimated delay is about [700ms~1500ms].*

(3) SIP signalling transfer delay

When the user plan is ready to send the INVITE message, the UE-A sends it to PoC AS, and then it forwards the INVITE message to PS Domain of UE-B.

→ *The estimated delay is less than [500ms]*

(4) Set up of Signalling Connection in the UE-B side

When the target SGSN receives the INVITE message, the SGSN shall establish a signalling connection in order to send the NAS signalling message to UE. This includes the Paging procedure, the RRC Connection Setup procedure, the Service Request procedure, and the Security Mode Command procedure.

The major delay comes from the Paging procedure and the RRC Connection Setup procedure.

→ *The estimated delay is about [700ms~1500ms].*

(5) Set up of RAB in the UE-B side

The terminating SGSN initiates the RAB Assignment procedure for the PDP Context for the IMS signalling in order to transmit the SIP INVITE message to the UE-B.

The major delay comes from the RAB assignment procedure which includes the RL reconfiguration procedure and the RB setup procedure.

→ *The estimated delay is about [700ms~1500ms].*

(6) Signalling transfer delay

The UE-B sends a SIP response message to the PoC AS (B). PoC AS (B) forwards the message to the PoC AS (A) and then the PoC AS (A) sends Talk Burst Confirm to the UE-A and Receiving Talk Burst to the UE-B.

→ *The estimated delay is less than [500ms]*

Therefore, the total estimated delay for the PoC session establishment (the time when the User-A initiates the PoC session ~ the time when the User-A can start to speak) is about [3800ms~7000ms].

## B.3 On demand session with automatic answer

Figure B.2 shows the delay components in case of the session establishment based on 'on demand session with automatic answer' signalling.

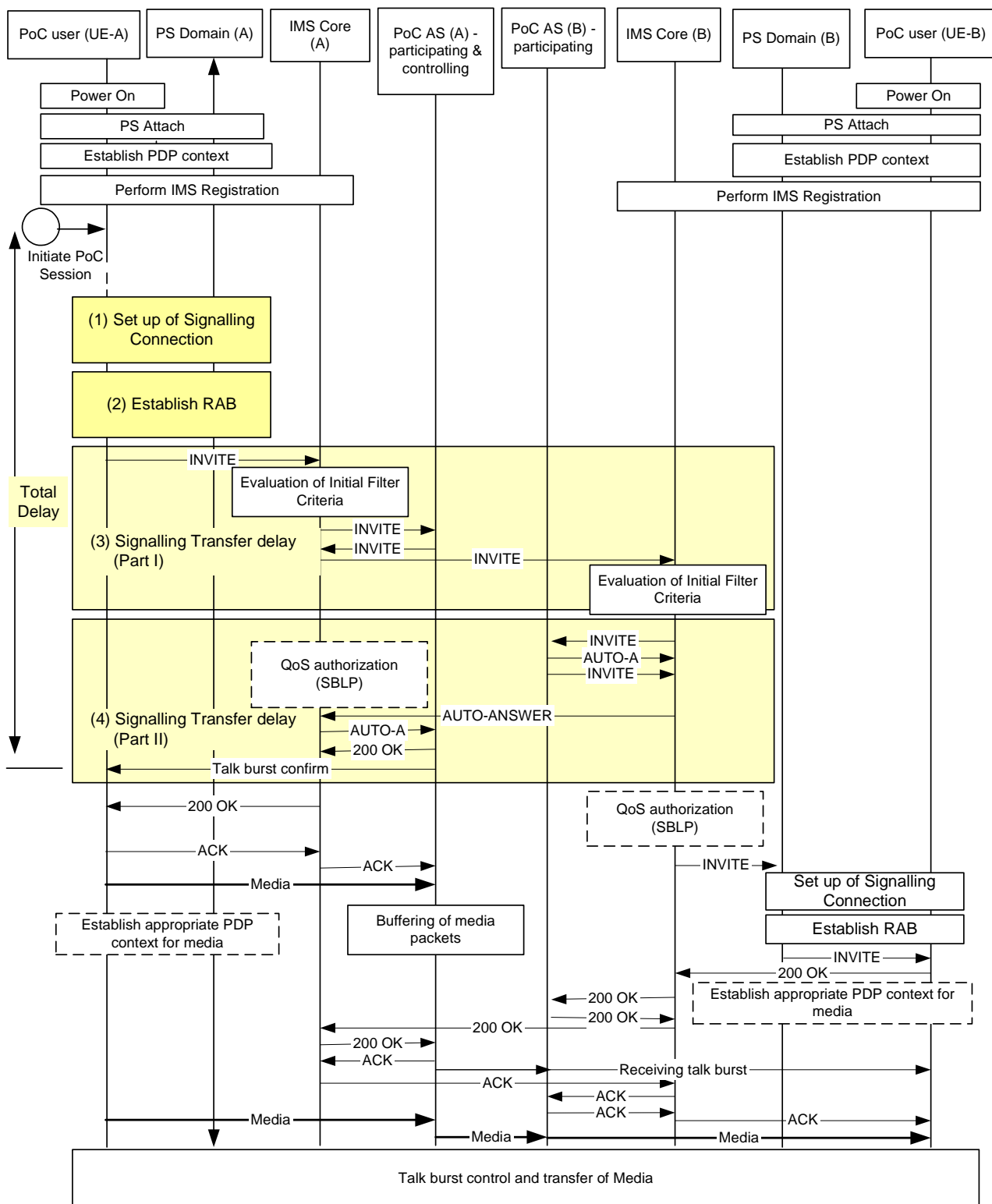

**Figure B.2 Delay component for the case of on demand session with automatic answer**

(1) Set up of Signalling Connection in the UE-A side

When the User-A initiates a PoC Session, the UE-A shall establish the signalling connection in order to send the NAS signalling. This includes the RRC Connection Setup procedure, the Service Request procedure and the Security Mode Command procedure.

This step is the same as that of the session establishment based on ‘on demand session with manual answer’.

→ The estimated delay is about [700ms~1500ms].



- (2) Establish Radio Access Bearer (RAB) in the UE-A side

RAB should be established for the existing PDP context through which the SIP INVITE message can be transmitted by the UE-A. This includes the RAB assignment procedure and the RL reconfiguration procedure and the RB setup procedure.

→ *The estimated delay is about [700ms~1500ms].*

- (3) SIP signalling transfer delay (Part I)

When the user plan is ready to send INVITE message, the UE-A sends the message to the PoC AS (A) and then PoC AS (A) forwards the message to the PoC AS (B).

→ *The estimated delay is less than [500ms]*

- (4) SIP signalling transfer delay (Part II)

For the Auto-answer mode, when PoC AS (B) receives the INVITE message, the PoC AS (B) sends the AUTO-ANSWER message to the PoC AS (A) without waiting for the response from the UE (B). The PoC AS (A) can send the Talk burst confirm to the UE-A when it receives AUTO-ANSWER message from the PoC AS (B).

→ *The estimated delay is less than [500ms]*

Therefore, the total estimated delay for the PoC session establishment (the time when the User-A initiates the PoC session ~ the time when the User-A can start to speak) is about [2400ms~4000ms].

Note that the delay of the session establishment using ‘on demand session with automatic answer’ can be about 2000ms (2 sec) smaller than that of the session establishment using ‘on demand session with manual answer’.

## B.4 On pre-established session

Figure B.3 shows the delay components in case of the session establishment based on ‘pre-established session’ signalling.

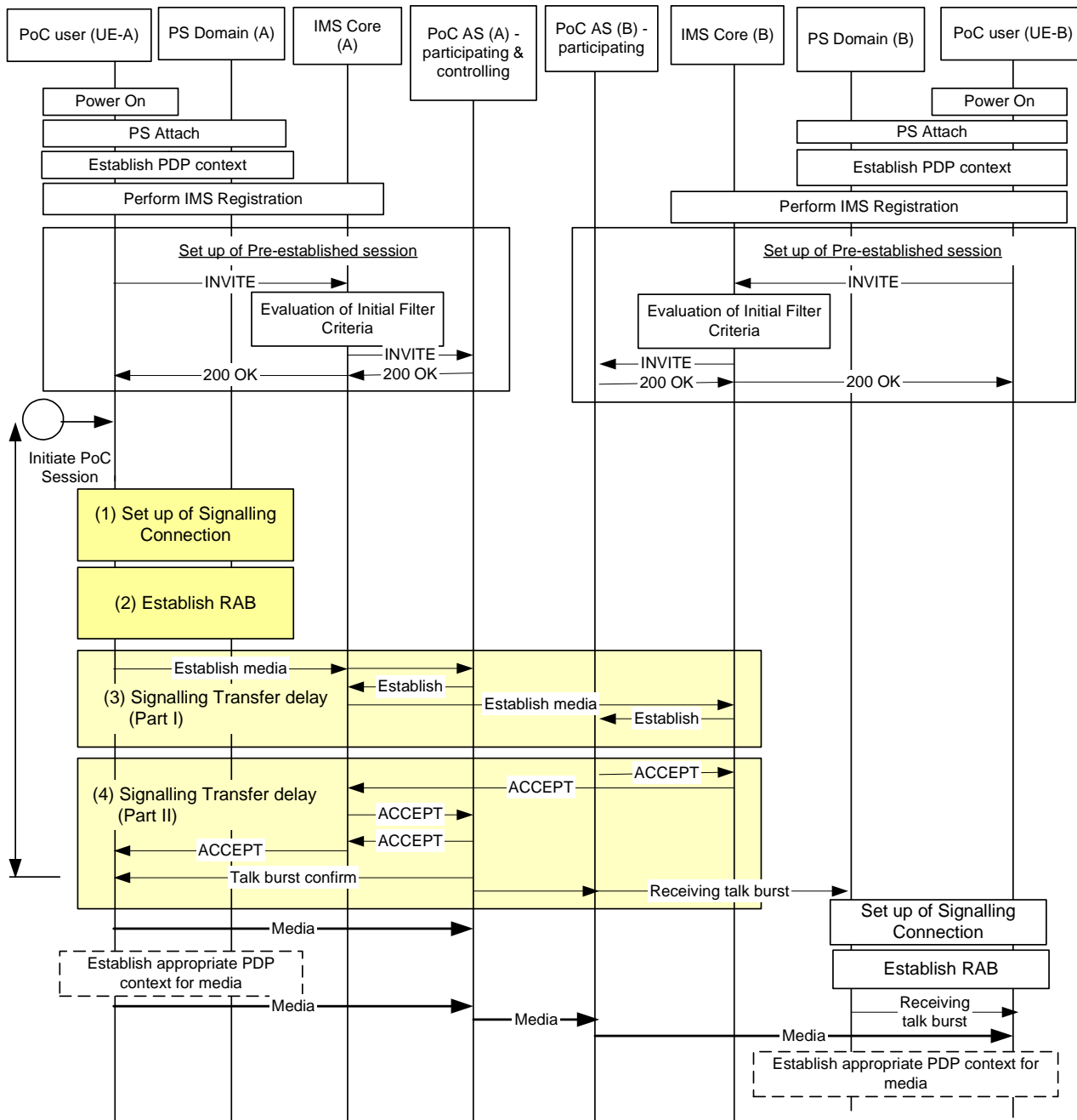

**Figure B.3 Delay component for the case of pre-established session**

(1) Set up of Signalling Connection in the UE-A side

When the User-A initiates a PoC Session, the UE-A shall establish the signalling connection in order to send the NAS signalling. This includes the RRC Connection Setup procedure, the Service Request procedure and the Security Mode Command procedure.

This step is the same as that of the session establishment based on ‘on demand session’.

→ The estimated delay is about [700ms~1500ms].

(2) Set up of RAB in the UE-A side

RAB should be established for the existing PDP context through which the SIP REFER message is transmitted by the UE-A.

This step is the same as that of the session establishment based on ‘on demand session’.

→ *The estimated delay is about [700ms~1500ms].*

(3) SIP signalling transfer delay (Part I)

When the user plan is ready to send the REFER message, the UE-A sends the message to the PoC AS (A) and then PoC AS (A) sends the INVITE message to the PoC AS (B).

→ *The estimated delay is less than [500ms]*

(4) SIP signalling transfer delay (Part II)

When it receives the REFER message, the PoC AS (B) sends the ACCEPT message to the PoC AS (A) without waiting for the response from the UE-B. It is possible because a 'pre-established session' has been set up beforehand. The PoC AS (A) sends the Talk burst confirm to the UE-A when it receives the ACCEPT message from the PoC AS (B).

→ *The estimated delay is less than [500ms]*

Therefore, the total estimated delay for the PoC session establishment (the time when the User-A initiates a PoC session ~ the time when the User-A can start to speak) is about [2400ms~4000ms].

Note that the delay of the session establishment using 'pre-established session' is almost the same as that of the session establishment of 'on demand session with automatic answer'.

---

## Annex C (Informative): Required SigComp performance

### C.1 Introduction

It is recognized that the SIP signalling transfer delay is dependent on:

- Size of the messages sent over the radio link, which is dependent on the performance of the signaling compression algorithm (SigComp, RFC 3320 [14]).
- Available bandwidth over the radio link for signaling, which is dependent on the maximum bit rate attribute settings for the PDP Context used for the PoC control plane traffic.

This annex contains the analysis of required SigComp performance in order to meet the delay budget for SIP signalling transfer delay presented in Annex B.

### C.2 Assumptions

The following assumptions have been used:

- The on demand session using automatic answer is used and the inviting PoC User is given an early “right-to-speak” indication as described in Section 5.3.2.2 and Section B.2.
- A typical SIP INVITE message in an OMA PoC implementation will have approximately the same size as the SIP INVITE message described as message 1 in Section 7.2.2.1 in 3GPP TS 24.228 [15]. The size of the referred SIP INVITE is 1375 bytes not including UDP (or TCP) and IP overhead, therefore for OMA PoC it is assumed that a SIP INVITE message will be in the order of 1400 bytes including UDP (or TCP) and IP overhead
- A typical SIP 200 OK message in an OMA PoC implementation will have approximately the same size as the SIP 200 OK message described as message 18 in Section 7.2.2.1 in 3GPP TS 24.228 [15]. Therefore for OMA PoC it is assumed that a SIP 200 OK message will be in the order of 800 bytes including UDP (or TCP) and IP overhead
- A SIP 100 Trying message must be sent over the radio link as acknowledgement of the SIP INVITE message. The size of the SIP 100 Trying is 300 bytes including UDP (or TCP) and IP overhead
- The talk burst confirm message is assumed to be 40 bytes including IP and UDP overhead
- The processing time in the UE to produce and compress a SIP message is 50 ms
- The delays imposed by all involved core network elements, including the core network of the radio access network (i.e. SGSN and GGSN) in a message transfer (IMS Core and PoC AS) are 100 ms.
- The duration between the times the inviting PoC User initiates the PoC session and when he receives a “right-to-speak” indication should be less than 2.0 seconds, as required in OMA\_RD PoC [7].
- All lower estimated delay values presented in Section B.2 apply

### C.3 Estimation of SIP compression ratios

The duration between the times the inviting PoC User initiates the PoC session and when he receives a “right-to-speak” indication shall be less than 2.0 seconds (2000 ms) according to OMA\_RD PoC [7]. It is assumed that all lower estimated delay values presented in Section B.2 applies. This means that a total delay budget of less than 2000 ms – 700 ms – 700 ms = 600 ms is assumed for the SIP signalling transfer delay (delay components (3) and (4)).

Table C.3-1 presents the delay budget given the assumptions presented in C.2.

**Table C.3-1: Detailed description of the delay budget for SIP signalling transfer delay**

<i>Action</i>	<i>Delay</i>	<i>Description</i>
The PoC Client produce and compress a SIP INVITE message	50 ms	
The PoC Client transmit the SIP INVITE message to the PoC AS:	*Radio transport delay of SIP INVITE + 100 ms	*Radio transport delay of SIP INVITE = (SIP message size * Compression ratio) / Bit rate of radio link
The IMS Core sends a SIP 100 Trying to acknowledge the reception of the SIP INVITE	**Radio transport delay of SIP 100 Trying	**Radio transport delay of SIP 100 Trying = (SIP message size * Compression ratio) / Bit rate of radio link
The PoC AS transmits the SIP 200 OK message to the PoC Client:	100 ms + ***Radio transport delay of SIP 200OK	***Radio transport delay of SIP 200OK = (SIP message size * Compression ratio) / Bit rate of radio link
The PoC AS transmits a talk burst confirmed message to the PoC Client:	****Radio transport delay of talk burst confirmed message	****Radio transport delay of talk burst confirmed message = (talk burst confirmed message size) / Bit rate of radio link
Total SIP signalling transfer delay:	50 ms + 100 ms + 100 ms + Radio transport delay of SIP INVITE + Radio transport delay of SIP 100 Trying + Radio transport delay of SIP 200OK + Radio transport delay of talk burst confirmed message < 600 ms	

The compression ratios of table C.3-2 is calculated by using the expression for the total SIP signalling transfer delay in Table C.3-1, and assuming a bit rate of the radio link used for the PoC control plane traffic

**Table C.3-2: Compression ratio as a function of Bit rate of the radio link**

<i>Bit rate of radio link</i>	<i>Compression ratio</i>
8 kbps	> 8.06:1
16 kbps	> 3.79:1
32 kbps	> 1.84:1
64 kbps	> 0.91:1

## C.4 SigComp requirements

Given that a low bit rate PS bearer (throughput < 16 kbps) is used for the PoC control plane traffic, SIP signalling compression ratios typically larger than 3:1 is needed to meet the delay requirement stated in OMA\_RD PoC [7]. Therefore it can be concluded that:

- The decompression byte code should be stored as a state and should not be sent from the transmitting node to the receiving node in every SigComp message. This implies that a SigComp implementation used for PoC should have a state memory size (SMS, see RFC 3320 [14]) larger than zero.
- An SMS that is larger than zero enables stateful compression, which probably is needed to obtain sufficient SIP signaling compression efficiency.
- The initial creation of the SigComp compartment (see RFC 3320 [14]) is done during IMS registration. The exchange and storing of the decompression byte codes is recommended to be performed during the non time critical SIP message exchange of the IMS Registration. This enables the transmission of compressed SIP messages without the overhead of decompression byte codes even in the first PoC Session after IMS Registration. However, the receiver of the byte codes cannot assume that the byte codes are sent only during the IMS registration.

The IMS support for SigComp is specified in TS 24.229 [16], which fulfills the requirements as stated above. Consequently, IMS provides sufficient SigComp support to fulfill the OMA delay requirements.

## Annex D: Change history

Change history							
Date	TSG #	TSG Doc.	CR	Rev	Subject/Comment	Old	New
2003-10					First draft version of the TR proposed		0.0.0
2003-11					Changes based on document S2-033751 in SA2#35	0.0.0	0.1.0
2003-12					Changes based on documents S2-034264 (which also the editor agreed to add a box around GLMS & PoC Server in diagram x) & S2-034337	0.1.0	0.2.0
2004-03					Changes based on documents S2-040826, S2-040989 & S2-040990 from SA2#38. Also updated the figure numbers and references in the text in section 5.	0.2.0	0.3.0
2004-05					Changes based on documents S2-041617, S2-041588 rev1, S2-041587 after SA2#39 meeting. Added reference to 23.207 for SBLP/Go and included 24.229 reference in the reference section. Some editorial and format corrections have been made to align with 3GPP rules.	0.3.0	0.4.0
2004-05					Editorial fixes of Flow 5.3.2 (steps inside pre-established session) now shows 5a and 5b and some other format fix.	0.4.0	0.5.0
2004-05					SA2#39 email approved correct document included (S2-041680), SA2#40 approved documents S2-042086, S2-042260, S2-042200, S2-042261 and S2-042254. Some editorial changes of enumerated bullets.	0.5.0	0.6.0
2004-05					Raised to v.1.0.0 for presentation at SA#24 (same content as v.0.6.0)	0.6.0	1.0.0
2004-06	SA#24	SP-040333			Presented for information	1.0.0	1.0.0
2004-08					SA2#41 approved documents S2-042886, S2-042899, S2-042693, S2-042734, S2-042884; Annex Change History renumbered from A to C, and the Caption of Figure 5.3.3 is aligned with other figures.	1.0.0	1.1.0
2004-10					SA2#42 approved documents S2-043366, S2-043357, and S2-043358; inserted the additional sentences to the figure headings in section 5.3.3.	1.1.0	1.2.0
2004-11					OMA references aligned to current document status, editorial correction in section 5.3.3.1	1.2.0	1.2.1
2004-11					SA2#43 approved documents S2-043813, S2-043819; Annex C Change History renamed to Annex D; Hanging paragraph corrected (new section B.1); renumbering section numbers in Annex B; Section 3.2. Symbols deleted; Renumbering section 3; Font text in new section B.1 last paragraph aligned with rest of paragraph.	1.2.1	1.3.0