

**Source: SA WG3**

**Title: SA WG3 LI Group CRs which were agreed by SA WG3 by e-mail  
(02/09/2004)**

**Document for: Approval**

**Agenda Item: 7.3.3**

The following CRs were agreed by SA WG3 by e-mail on 2 September 2004 and are presented to TSG SA for approval.

SA WG3 Doc number	Spec	CR	Rev	Phase	Subject	Cat	Version-Current	LI Group Doc number	Work item
S3-040693	33.107	044	-	Rel-6	Correction on the use of session initiator parameter	F	6.2.0	S3LI04_113	SEC1-LI
S3-040693	33.107	045	-	Rel-6	ICE (Intercepting Control Elements), INE (Intercepting Network Elements) definition	F	6.2.0	S3LI04_117r2	SEC1-LI
S3-040693	33.107	046	-	Rel-6	Clarification to SMS interception	F	6.2.0	S3LI04_128r2	SEC1-LI
S3-040693	33.107	047	-	Rel-6	Replace SIP URL with SIP URI	F	6.2.0	S3LI04_130r3	SEC1-LI
S3-040693	33.108	050	-	Rel-6	Explanation concerning the Sequence Number	F	6.6.0	S3LI04_103r3	SEC1-LI
S3-040693	33.108	051	-	Rel-6	National ASN.1 parameter	B	6.6.0	S3LI04_106r3	SEC1-LI
S3-040693	33.108	052	-	Rel-6	Clarifying clause titles	D	6.6.0	S3LI04_109r2	SEC1-LI
S3-040693	33.108	053	-	Rel-6	Adding azimuth in location	B	6.6.0	S3LI04_110r3	SEC1-LI
S3-040693	33.108	054	-	Rel-6	Correction of the Subaddressing definitions	C	6.6.0	S3LI04_115r2	SEC1-LI
S3-040693	33.108	055	-	Rel-6	Correction to hi3DomainId definition	F	6.6.0	S3LI04_124r7	SEC1-LI
S3-040693	33.108	056	-	Rel-6	Correction of wrong use of abbreviations	D	6.6.0	S3LI04_125r1	SEC1-LI
S3-040693	33.108	057	-	Rel-6	Differences between subaddress sections in 33.108 and ETSI TS 101 671	C	6.6.0	S3LI04_129r2	SEC1-LI
S3-040693	33.108	058	-	Rel-6	Replace SIP URL with SIP URI	F	6.6.0	S3LI04_132r2	SEC1-LI
S3-040693	33.108	059	-	Rel-6	Corrections to References	F	6.6.0	S3LI04_143r5	SEC1-LI

CR-Form-v7

## CHANGE REQUEST

**33.107 CR 044** rev - Current version: **6.2.0**

For **HELP** on using this form, see bottom of this page or look at the pop-up text over the symbols.

Proposed change affects:  UICC apps  ME  Radio Access Network  Core Network

<b>Title:</b>	Correction on the use of session initiator parameter		
<b>Source:</b>	ESTS – FBI/CIU		
<b>Work item code:</b>	SEC1-LI	<b>Date:</b>	2004-07-20
<b>Category:</b>	<b>F</b>	<b>Release:</b>	Rel-6
	Use <u>one</u> of the following categories: <b>F</b> (correction) <b>A</b> (corresponds to a correction in an earlier release) <b>B</b> (addition of feature), <b>C</b> (functional modification of feature) <b>D</b> (editorial modification) Detailed explanations of the above categories can be found in 3GPP <a href="#">TR 21.900</a> .		Use <u>one</u> of the following releases: 2 (GSM Phase 2) R96 (Release 1996) R97 (Release 1997) R98 (Release 1998) R99 (Release 1999) Rel-4 (Release 4) Rel-5 (Release 5) Rel-6 (Release 6)

<b>Reason for change:</b>	To achieve consistency with TS 33.108 and §6.3.2 as well as §6.3.4.1 of TS 33.107 regarding the use of the terms “Session Initiator” and “Initiator”, changes are proposed to §7 of TS 33.107.
<b>Summary of change:</b>	The term “Session Initiator” is changed to “Initiator” while the current use of “Initiator” is changed to “SMS Initiator” within §7 of TS 33.107.
<b>Consequences if not approved:</b>	Misalignments between different sections of TS 33.107 and between TS 33.107 and TS 33.108 for the use of session initiator parameter. Also, maintains confusion for implementors of the specification.

<b>Clauses affected:</b>	7.3.2, 7.4.3, 7.4.4, 7.4.5, 7.4.7, and 7.4.8										
<b>Other specs affected:</b>	<table border="1" style="display: inline-table; border-collapse: collapse;"> <tr> <td style="width: 20px; text-align: center;">Y</td> <td style="width: 20px; text-align: center;">N</td> </tr> <tr> <td style="text-align: center;"><input type="checkbox"/></td> <td style="text-align: center;"><input checked="" type="checkbox"/></td> </tr> <tr> <td style="text-align: center;"><input type="checkbox"/></td> <td style="text-align: center;"><input checked="" type="checkbox"/></td> </tr> <tr> <td style="text-align: center;"><input type="checkbox"/></td> <td style="text-align: center;"><input checked="" type="checkbox"/></td> </tr> </table>	Y	N	<input type="checkbox"/>	<input checked="" type="checkbox"/>	<input type="checkbox"/>	<input checked="" type="checkbox"/>	<input type="checkbox"/>	<input checked="" type="checkbox"/>	Other core specifications Test specifications O&M Specifications	
Y	N										
<input type="checkbox"/>	<input checked="" type="checkbox"/>										
<input type="checkbox"/>	<input checked="" type="checkbox"/>										
<input type="checkbox"/>	<input checked="" type="checkbox"/>										
<b>Other comments:</b>											

**\*\*\* FIRST MODIFICATION \*\*\*****7.3.2 Structure of the events**

There are eight different events in which the information is sent to the DF2 if this is required. Details are described in the following section. The events for interception are configurable (if they are sent to DF2) in the 3G GSN or the HLR and can be suppressed in the DF2.

**The following events are applicable to 3G SGSN:**

- Mobile Station Attach;
- Mobile Station Detach;
- PDP context activation;
- Start of intercept with PDP context active;
- PDP context modification;
- PDP context deactivation;
- RA update;
- SMS.

NOTE: 3G GGSN interception is a national option. Location information may not be available in this case.

**The following events are applicable to the 3G GGSN:**

- PDP context activation;
- PDP context modification;
- PDP context deactivation;
- Start of interception with PDP context active.

**The following events are applicable to the HLR:**

- Serving System.

A set of fields as shown below is used to generate the events. The events transmit the information from 3G GSN or HLR to DF2. This set of fields as shown below can be extended in the 3G GSN or HLR, if this is necessary as a national option. DF2 can extend this information if this is necessary as a national option e.g. a unique number for each surveillance warrant.

Table 2: Information Events for Packet Data Event Records

Observed MSISDN MSISDN of the target subscriber (monitored subscriber).
Observed IMSI IMSI of the target subscriber (monitored subscriber).
Observed IMEI IMEI of the target subscriber (monitored subscriber), it shall be checked for each activation over the radio interface.
Event type Description which type of event is delivered: MS attach, MS detach, PDP context activation, Start of intercept with PDP context active, PDP context deactivation, SMS, Serving System, Cell and/or RA update.
Event date Date of the event generation in the 3G GSN or the HLR.
Event time Time of the event generation in the 3G GSN or the HLR. Timestamp shall be generated relative to GSN or HLR internal clock.
PDP address The PDP address of the target subscriber. Note that this address might be dynamic.
Access Point Name The APN of the access point. (Typically the GGSN of the other party).
Location Information Location Information is the Service Area Identity (SAI), RAI and/or location area identity that is present at the GSN at the time of event record production.
Old Location Information Location Information of the subscriber before Routing Area Update
PDP Type The used PDP type.
Correlation Number The correlation number is used to correlate CC and IRI.
SMS The SMS content with header which is sent with the SMS-service. The header also includes the SMS-Centre address.
Network Element Identifier Unique identifier for the element reporting the ICE.
Failed attach reason Reason for failed attach of the target subscriber.
Failed context activation reason Reason for failed context activation of the target subscriber.
IAs The observed Interception Areas.
<del>Session</del> -Initiator The initiator of the PDP context activation, deactivation or modification request either the network or the 3G MS.
SMS Initiator SMS indicator whether the SMS is MO or MT.
Deactivation / termination cause The termination cause of the PDP context.
QoS This field indicates the Quality of Service associated with the PDP Context procedure.
Serving System Address Information about the serving system (e.g. serving SGSN number or serving SGSN address).

### \*\*\* NEXT MODIFICATION \*\*\*

#### 7.4.3 Packet Data PDP context activation

For PDP context activation a PDP context activation-event is generated. When a PDP context activation is generated from the mobile to 3G GSN this event is generated. These fields will be delivered to the DF2 if available:

Observed MSISDN
Observed IMSI
Observed IMEI
PDP address of observed party
Event Type
Event Time
Event Date
Correlation number
Access Point Name
PDP Type
Network Element Identifier
Location Information
Failed context activation reason
IAs (if applicable)
<del>Session</del> -Initiator (optional)
QoS (optional)

### \*\*\* NEXT MODIFICATION \*\*\*

#### 7.4.4 Start of interception with PDP context active

This event will be generated if interception for a target is started and if the target has at least one PDP context active. If more than one PDP context are open for each of them an event record is generated. These fields will be delivered to the DF2 if available:

Observed MSISDN
Observed IMSI
Observed IMEI
PDP address of observed party
Event Type
Event Time
Event Date
Correlation number
Access Point Name
PDP Type
Network Element Identifier
Location Information
Old Location Information (optional)
IAs (if applicable)
QoS (optional)
<del>Session</del> -Initiator (optional)

Presence of the optional Old Location Information field indicates that PDP context was already active, and being intercepted. However, the absence of this information does not imply that interception has not started in the old location SGSN for an active PDP context.

**\*\*\* NEXT MODIFICATION \*\*\***

**7.4.5 Packet Data PDP context deactivation**

At PDP context deactivation a PDP context deactivation-event is generated. These fields will be delivered to the DF2 if available:

Observed MSISDN
Observed IMSI
Observed IMEI
PDP address of observed party
Event Type
Event Time
Event Date
Correlation number
Access point name
Network Element Identifier
Location Information
IAs (if applicable)
Deactivation cause
<del>Session initiator</del> Initiator (optional)

**\*\*\* NEXT MODIFICATION \*\*\***

**7.4.7 SMS**

For MO-SMS the event is generated in the 3G SGSN. Dependent on national requirements, event generation shall occur either when the 3G SGSN receives the SMS from the target MS or when the 3G SGSN receives notification that the SMS-Centre successfully receives the SMS; for MT-SMS the event is generated in the 3G SGSN. Dependent on national requirements, event generation shall occur either when the 3G SGSN receives the SMS from the SMS-Centre or when the 3G SGSN receives notification that the target MS successfully received the message. ~~This~~ These fields will be delivered to the DF2 if available:

Observed MSISDN
Observed IMSI
Observed IMEI
Event Type
Event Time
Event Date
Network Element Identifier
Location Information
SMS
<u>SMS</u> Initiator
IAs (if applicable)

**\*\*\* NEXT MODIFICATION \*\*\***

## 7.4.8 Packet Data PDP context modification

This event will be generated if interception for a target is started and if the target has at least one PDP context active. These fields will be delivered to the DF2 if available:

Observed MSISDN
Observed IMSI
Observed IMEI
PDP address of observed party
Event Type
Event Time
Event Date
Correlation number
Access Point Name
PDP Type
Network Element Identifier
Location Information
IAs (if applicable)
<del>Session</del> Initiator
QoS

**\*\*\* END OF MODIFICATIONS \*\*\***

## CHANGE REQUEST

**33.107 CR 045** rev - Current version: **6.2.0**

For **HELP** on using this form, see bottom of this page or look at the pop-up text over the symbols.

**Proposed change affects:** | UICC apps  ME  Radio Access Network  Core Network

<b>Title:</b>	ICE (Intercepting Control Elements), INE (Intercepting Network Elements) definition		
<b>Source:</b>	SA WG3 (LI Group)		
<b>Work item code:</b>	SEC1-LI	<b>Date:</b>	07/07/2004
<b>Category:</b>	<b>F</b>	<b>Release:</b>	Rel-6
	Use <u>one</u> of the following categories: <b>F</b> (correction) <b>A</b> (corresponds to a correction in an earlier release) <b>B</b> (addition of feature), <b>C</b> (functional modification of feature) <b>D</b> (editorial modification) Detailed explanations of the above categories can be found in 3GPP <a href="#">TR 21.900</a> .		Use <u>one</u> of the following releases: 2 (GSM Phase 2) R96 (Release 1996) R97 (Release 1997) R98 (Release 1998) R99 (Release 1999) Rel-4 (Release 4) Rel-5 (Release 5) Rel-6 (Release 6)

<b>Reason for change:</b>	Update was not done with the HLR CR's
<b>Summary of change:</b>	Extension of ICE and INE definition with HLR
<b>Consequences if not approved:</b>	Missing information / not in line with the document

<b>Clauses affected:</b>	3.2						
<b>Other specs affected:</b>	<table border="1" style="display: inline-table; border-collapse: collapse;"> <tr> <td style="padding: 2px;">Y</td> <td style="padding: 2px;">N</td> </tr> <tr> <td style="padding: 2px;"><input type="checkbox"/></td> <td style="padding: 2px;"><input checked="" type="checkbox"/></td> </tr> </table>	Y	N	<input type="checkbox"/>	<input checked="" type="checkbox"/>	Other core specifications	
	Y	N					
	<input type="checkbox"/>	<input checked="" type="checkbox"/>					
<input checked="" type="checkbox"/>	Test specifications						
<input checked="" type="checkbox"/>	O&M Specifications						
<b>Other comments:</b>							



\*\*\*\* **Changes** \*\*\*\*

## 3.2 Abbreviations

For the purposes of the present document, the following abbreviations apply:

3GPP MS	3rd Generation Mobile Communication System
3G GGSN	3rd Generation Gateway GPRS Support Node
3G GSN	3rd Generation GPRS Support Node (GGSN/SGSN)
3G MSC	3rd Generation Mobile Switching Center
3G SGSN	3rd Generation Serving GPRS Support Node
3G UMSC	3rd Generation Unified Mobile Switching Centre
ADMF	Administration Function
CC	Content of Communication
DF	Delivery Function
ECT	Explicit Call Transfer
GPRS	General Packet Radio Service
HI	Handover Interface
IA	Interception Area
ICEs	Intercepting Control Elements (3G MSC Server, 3G GMSC Server, P-CSCF, S-CSCF, SGSN, GGSN, <a href="#">HLR</a> )
IMS	IP Multimedia Core Network Subsystem
INEs	Intercepting Network Elements (3G MSC Server, 3G GMSC Server, P-CSCF, S-CSCF, SGSN, GGSN, MGW, <a href="#">HLR</a> )
IP	Internet Protocol
IRI	Intercept Related Information
LDI	Location Dependent Interception
LEA	Law Enforcement Agency
LEMF	Law Enforcement Monitoring Facility
RA	Routing Area
RAI	Routing Area Identity
SAI	Service Area Identity
TEL URL	"tel" URL, as defined in [9]

## CHANGE REQUEST

**33.107 CR 046** rev - Current version: **6.2.0**

For **HELP** on using this form, see bottom of this page or look at the pop-up text over the symbols.

Proposed change affects:  UICC apps  ME  Radio Access Network  Core Network

<b>Title:</b>	Clarification to SMS interception		
<b>Source:</b>	SA WG3 (LI Group)		
<b>Work item code:</b>	SEC-LI	<b>Date:</b>	14.07.2004
<b>Category:</b>	<b>F</b>	<b>Release:</b>	Rel-6
	Use <u>one</u> of the following categories: <b>F</b> (correction) <b>A</b> (corresponds to a correction in an earlier release) <b>B</b> (addition of feature), <b>C</b> (functional modification of feature) <b>D</b> (editorial modification) Detailed explanations of the above categories can be found in 3GPP <a href="#">TR 21.900</a> .		Use <u>one</u> of the following releases: 2 (GSM Phase 2) R96 (Release 1996) R97 (Release 1997) R98 (Release 1998) R99 (Release 1999) Rel-4 (Release 4) Rel-5 (Release 5) Rel-6 (Release 6)

<b>Reason for change:</b>	Once intercepting SMS at SGSN, in some cases it is not allowed to deliver SMS contents to LEMF. This should be clarified in the spec.
<b>Summary of change:</b>	Clarifications to SMS interception.
<b>Consequences if not approved:</b>	Inconsistency with 33.108.

<b>Clauses affected:</b>	7.1						
<b>Other specs affected:</b>	<table border="1" style="display: inline-table; border-collapse: collapse;"> <tr> <td style="width: 20px; text-align: center;">Y</td> <td style="width: 20px; text-align: center;">N</td> </tr> <tr> <td style="text-align: center;"><input type="checkbox"/></td> <td style="text-align: center;"><input checked="" type="checkbox"/></td> </tr> </table> Other core specifications	Y	N	<input type="checkbox"/>	<input checked="" type="checkbox"/>		
Y	N						
<input type="checkbox"/>	<input checked="" type="checkbox"/>						
	<table border="1" style="display: inline-table; border-collapse: collapse;"> <tr> <td style="width: 20px; text-align: center;">X</td> </tr> <tr> <td style="text-align: center;"><input checked="" type="checkbox"/></td> </tr> </table> Test specifications	X	<input checked="" type="checkbox"/>				
X							
<input checked="" type="checkbox"/>							
	<table border="1" style="display: inline-table; border-collapse: collapse;"> <tr> <td style="width: 20px; text-align: center;">X</td> </tr> <tr> <td style="text-align: center;"><input checked="" type="checkbox"/></td> </tr> </table> O&M Specifications	X	<input checked="" type="checkbox"/>				
X							
<input checked="" type="checkbox"/>							
<b>Other comments:</b>							

## 7.1 Provision of Intercept Product - Short Message Service

Figure 19 shows an SMS transfer from the 3G SGSN node to the LEA. Quasi-parallel to the delivery from / to the mobile subscriber an [SMS event message](#), which contains the content and header of the SMS, is generated and sent via the Delivery Function 2 to the LEA in the same way as the Intercept Related Information. [National regulations and warrant type determine if SMS event shall contain only SMS header, or SMS header and SMS content.](#)

The IRI will be delivered to the LEA:

- for a SMS-MO. Dependent on national requirements, delivery shall occur either when the 3G SGSN receives the SMS from the target MS or when the 3G SGSN receives notification that the SMS-Centre successfully received the SMS;
- for a SMS-MT. Dependent on national requirements, delivery shall occur either when the 3G SGSN receives the SMS from the SMS-Centre or when the 3G SGSN receives notification that the target MS successfully received the SMS.

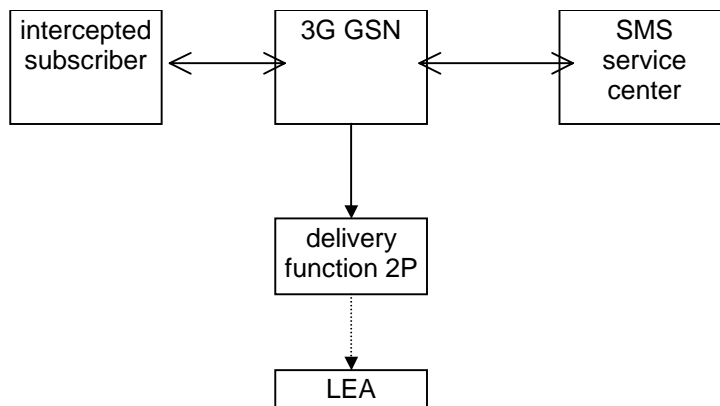

**Figure 19: Provision of Intercept Product - Short Message Service**

## CHANGE REQUEST

**33.107 CR 047** rev - Current version: **6.2.0**

For **HELP** on using this form, see bottom of this page or look at the pop-up text over the symbols.

**Proposed change affects:** UICC apps  ME  Radio Access Network  Core Network

<b>Title:</b>	Replace SIP URL with SIP URI		
<b>Source:</b>	SA WG3 (LI Group)		
<b>Work item code:</b>	SEC1-LI	<b>Date:</b>	12-07-2004
<b>Category:</b>	<b>F</b>	<b>Release:</b>	Rel-6
	<i>Use one of the following categories:</i> <b>F</b> (correction) <b>A</b> (corresponds to a correction in an earlier release) <b>B</b> (addition of feature), <b>C</b> (functional modification of feature) <b>D</b> (editorial modification) Detailed explanations of the above categories can be found in 3GPP <a href="#">TR 21.900</a> .		<i>Use one of the following releases:</i> 2 (GSM Phase 2) R96 (Release 1996) R97 (Release 1997) R98 (Release 1998) R99 (Release 1999) Rel-4 (Release 4) Rel-5 (Release 5) Rel-6 (Release 6)

<b>Reason for change:</b>	To be consistent with RFC 3261 and TS24.229 SIP usage
<b>Summary of change:</b>	The SIP URL is no longer used in RFC 3261 and TS 24.229. It has been changed to SIP URI to better reflect the usage.
<b>Consequences if not approved:</b>	If not change, there will be inconsistent with RFC3261 and TS24.229 and cause confusion.

<b>Clauses affected:</b>	2, 3.2, 5.1.1, 7.A.2, 7.A.3										
<b>Other specs affected:</b>	<table border="1" style="display: inline-table; border-collapse: collapse;"> <tr> <td style="text-align: center;">Y</td> <td style="text-align: center;">N</td> </tr> <tr> <td style="text-align: center;">X</td> <td style="text-align: center;"></td> </tr> <tr> <td style="text-align: center;"></td> <td style="text-align: center;">X</td> </tr> <tr> <td style="text-align: center;"></td> <td style="text-align: center;">X</td> </tr> </table> Other core specifications Test specifications O&M Specifications	Y	N	X			X		X		33.108
Y	N										
X											
	X										
	X										
<b>Other comments:</b>											

\*\*\*\* Change 1 \*\*\*\*

## 2 References

The following documents contain provisions which, through reference in this text, constitute provisions of the present document.

- References are either specific (identified by date of publication, edition number, version number, etc.) or non-specific.
- For a specific reference, subsequent revisions do not apply.
- For a non-specific reference, the latest version applies. In the case of a reference to a 3GPP document (including a GSM document), a non-specific reference implicitly refers to the latest version of that document *in the same Release as the present document*.

- [1] ETSI TS 101 331: "Telecommunications security; Lawful Interception (LI); Requirements of Law Enforcement Agencies".
- [2] ETSI ES 201 158: "Lawful Interception; Requirements for network functions".
- [3] ETSI ES 201 671: "Handover Interface for the lawful interception of telecommunications traffic".
- [4] GSM 01.33: "Lawful Interception requirements for GSM".
- [5] GSM 02.33: "Lawful Interception - stage 1".
- [6] GSM 03.33: "Lawful Interception - stage 2".
- [7] 3GPP TS 33.106: "3rd Generation Partnership Project; Technical Specification Group Services and System Aspects; 3G Security; Lawful Interception Requirements".
- [8] ANSI J-STD-025-A: "Lawfully Authorised Electronic Surveillance".
- [9] IETF RFC 2806: "URLs for Telephone Calls".
- [10] 3GPP TS 23.060: "3rd Generation Partnership Project; Technical Specification Group Services and System Aspects; General Packet Radio Service (GPRS); Service description".
- [11] 3GPP TS 33.108: "3rd Generation Partnership Project; Technical Specification Group Services and System Aspects; 3G Security; Handover interface for Lawful Interception".
- [12] [IETF RFC 3261: "SIP: Session Initiation Protocol"](#)

\*\*\*\* Change 2 \*\*\*\*

## 3.2 Abbreviations

For the purposes of the present document, the following abbreviations apply:

3GPP MS	3rd Generation Mobile Communication System
3G GGSN	3rd Generation Gateway GPRS Support Node
3G GSN	3rd Generation GPRS Support Node (GGSN/SGSN)
3G MSC	3rd Generation Mobile Switching Center
3G SGSN	3rd Generation Serving GPRS Support Node
3G UMSC	3rd Generation Unified Mobile Switching Centre
ADMF	Administration Function
CC	Content of Communication
DF	Delivery Function
ECT	Explicit Call Transfer

GPRS	General Packet Radio Service
HI	Handover Interface
IA	Interception Area
ICEs	Intercepting Control Elements (3G MSC Server, 3G GMSC Server, P-CSCF, S-CSCF, SGSN, GGSN)
IMS	IP Multimedia Core Network Subsystem
INEs	Intercepting Network Elements (3G MSC Server, 3G GMSC Server, P-CSCF, S-CSCF, SGSN, GGSN, MGW)
IP	Internet Protocol
IRI	Intercept Related Information
LDI	Location Dependent Interception
LEA	Law Enforcement Agency
LEMF	Law Enforcement Monitoring Facility
RA	Routing Area
RAI	Routing Area Identity
SAI	Service Area Identity
<u>SIP</u>	<u>Session Initiation Protocol</u>
TEL URL	"tel" URL, as defined in [9]
<u>URI</u>	<u>Universal Resource Identifier</u>
<u>URL</u>	<u>Universal Resource Locator</u>

\*\*\*\* Change 3 \*\*\*\*

## 5 Activation, deactivation and interrogation

Figure 2 is an extraction from the reference intercept configuration shown in figure 1 which is relevant for activation, deactivation and interrogation of the lawful interception.

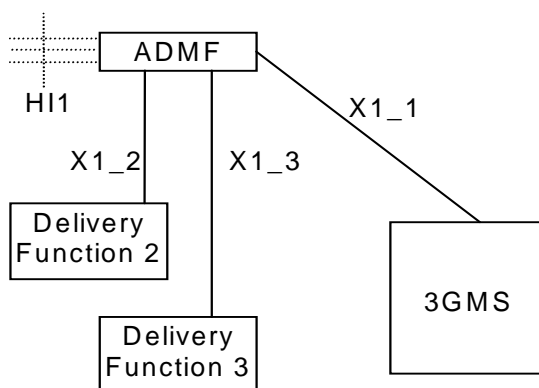

**Figure 2: Functional model for Lawful Interception activation, deactivation and interrogation**

In addition to the typical 3G ICEs functional entities, a new functional entity is introduced - the ADMF - the Lawful Interception administration function. The ADMF:

- interfaces with all the LEAs that may require interception in the intercepting network;
- keeps the intercept activities of individual LEAs separate;
- interfaces to the intercepting network.

Every physical 3G ICE is linked by its own X1\_1-interface to the ADMF. Consequently, every single 3G ICE performs interception (activation, deactivation, interrogation as well as invocation) independently from other 3G ICEs. The HI1-interface represents the interface between the requester of the lawful interception and the Lawful administration function; it is included for completeness, but is beyond the scope of standardisation in this document.

The target identities for 3GPP MS CS and PS interception at the SGSN, GGSN, 3G MSC Server and 3G GMSC Server can be at least one of the following: IMSI, MSISDN or IMEI.

NOTE 1: Some communication content during a mobility procedure may not be intercepted when interception is based on MSISDN (only PS interception) or IMEI. The use of the IMSI does not have this limitation. For the availability of the target identities IMSI, MSISDN and IMEI (PS interception), refer to [10].

The target identities for multi-media at the CSCF can be one or more of the following: SIP URI or TEL URL. Other identities are for further study.

In case of location dependent interception the following network/national options exist:

- target location versus Interception Areas (IAs) check in the 3G ICEs and Delivery Functions (DFs);
- target location versus IAs check in the DFs (physical collocation of the DFs to the 3G ICEs may be required by national law).

NOTE 2: The IA is previously defined by a set of cells. From the location of the target this set of cells permits to find the relevant IA.

NOTE 3: It is not required that the 3G GMSC or the 3G GGSN are used for interception when Location Dependent Interception is invoked and the location of the target is not available.

Editors' note: Location dependent intercept at the CSCF is for further study.

Editors' note: Location dependent intercept for the 3G MSC Server and SSGN is for further study.

The ADMF shall be able to provision P-CSCFs independently from S-CSCFs. If both P-CSCFs and S-CSCFs are administered within the network for intercept, redundant multi-media IRI may be presented to the agency as a result.

\*\*\*\* Change 4 \*\*\*\*

### 5.1.1 X1\_1-interface

The messages sent from the ADMF to the 3G ICEs (X1\_1-interface) contain the:

- target identities (MSISDN, IMSI, IMEI, SIP URI or TEL URL) (see notes 4 and 5);
- information whether the Content of Communication (CC) shall be provided (see note 1);
- address of Delivery Function 2 (DF2) for the intercept related information (see note 2);
- address of Delivery Function 3 (DF3) for the intercepted content of communications (see note 3);
- IA in case of location dependent interception.

NOTE 1: As an option, the filtering whether intercept product and/or intercept related information has to be provided can be part of the delivery functions. (Note that intercept product options do not apply at the CSCF). If the option is used, the corresponding information can be omitted on the X1\_1-interface, while "information not present" means "intercept product and related information has to be provided" for the ICE. Furthermore the delivery function which is not requested has to be "pseudo-activated", in order to prevent error cases at invocation.

NOTE 2: As an option, only a single DF2 is used by and known to every 3G ICE. In this case the address of DF2 can be omitted.

NOTE 3: As an option, only a single DF3 is used by and known to every 3G ICE (except at the CSCFs). In this case the address of DF3 can be omitted.

NOTE 4: Since the IMEI is not available, interception based on IMEI is not applicable at the 3G Gateway. Moreover, in case the IMEI is not available, interception based on IMEI is not applicable at 3G ICEs.

NOTE 5: Interception at the CSCFs is based upon either SIP URI or TEL URL. SIP URI and TEL URL as target identities are not supported by the other ICEs.

If after activation subsequently Content of Communications (CC) or Intercept Related Information (IRI) has to be activated (or deactivated) an "activation change request" with the same identity of the target is to be sent.

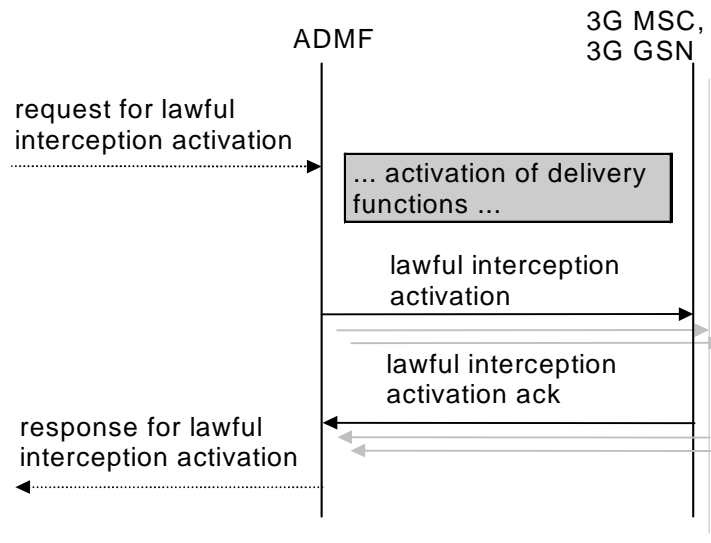

**Figure 3: Information flow on X1\_1-interface for Lawful Interception activation**

Interception of a target can be activated on request from different LEAs and each LEA may request interception via a different identity. In this case, each target identity on which to intercept will need to be sent via separate activation messages from ADMF to the 3G ICEs on the X1\_1-interface. Each activation can be for IRI only, or both CC and IRI.

When several LEAs request activation on the same identity then the ADMF determines that there are existing activations on the identity. In this case, the ADMF may (as an implementation option) send an additional activation message to the 3G ICEs. When the activation needs to change from IRI only to CC and IRI an activation change message will be sent to the 3G ICEs.

In case of a secondary interception activation only the relevant LEAs will get the relevant IRIs.

\*\*\*\* Change 5 \*\*\*\*

## 7A.2 Provision of IRI

SIP messaging is reported as Intercept Related Information for the interception of multi-media service. As shown in figure 22 below, all SIP messages executed on behalf of a target subscriber are subject to intercept at the P CSCF and S CSCF. Based upon network configuration, the ADMF shall provision P CSCFs, or S CSCFs, or both P CSCFs and S CSCFs with SIP URI or TEL URL target identifiers. These resulting intercepted SIP messages shall be sent to DF2 for mediation prior to transmittal across the HI2 interface.



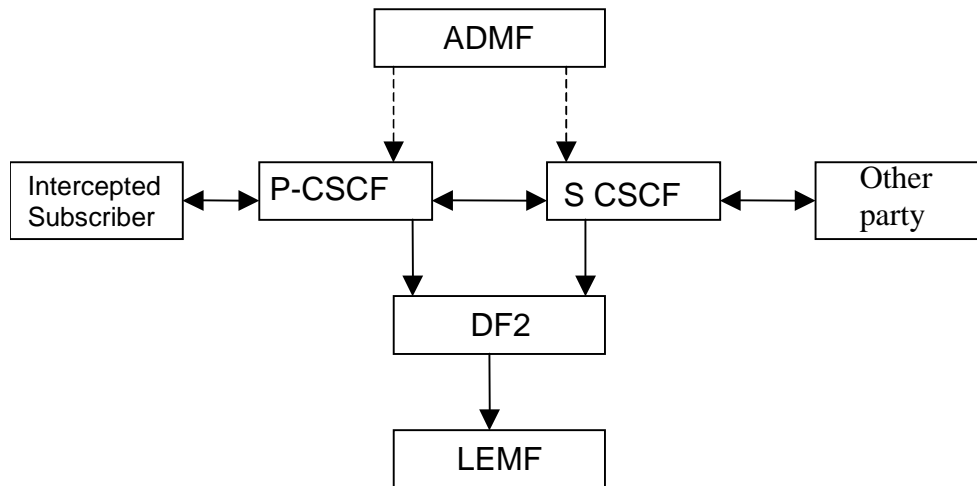

Figure 22: Provision of Intercept Related Information for multi-media

### 7A.3 Multi-media events

- All SIP messages to or from a targeted subscriber, and all SIP messages executed on behalf of a targeted subscriber for multi-media session control are intercepted by the P-CSCF and S-CSCF and sent to DF2. The target identifier used to trigger the intercept will also be sent with the SIP message. P-CSCF event reports may be redundant with S-CSCF event reports when the P-CSCF and S-CSCF reside in the same network, however, this standard does not require nor prohibit redundant information from being reported to DF2.
- The IRI should be sent to DF2 with a reliable transport mechanism.
- The reporting of location information for the sake of location dependent intercept is for further study.
- The use of a correlation ID for SIP to bearer correlation is a topic for further study.
- An intercepted SIP event sent to DF2 is shown below:
  - Observed SIP URI
  - Observed TEL URL
  - Event Time and Date
  - Network element identifier
  - SIP Message Header
  - SIP Message Payload

## CHANGE REQUEST

**33.108 CR 050** rev - Current version: **6.6.0**

For **HELP** on using this form, see bottom of this page or look at the pop-up text over the symbols.

**Proposed change affects:** | UICC apps  ME  Radio Access Network  Core Network

<b>Title:</b>	Explanation concerning the Sequence Number		
<b>Source:</b>	SA WG3 (LI Group)		
<b>Work item code:</b>	SEC1-LI	<b>Date:</b>	20/07/2004
<b>Category:</b>	<b>F</b>	<b>Release:</b>	Rel-6
	Use <u>one</u> of the following categories: <b>F</b> (correction) <b>A</b> (corresponds to a correction in an earlier release) <b>B</b> (addition of feature), <b>C</b> (functional modification of feature) <b>D</b> (editorial modification) Detailed explanations of the above categories can be found in 3GPP <a href="#">TR 21.900</a> .		Use <u>one</u> of the following releases: 2 (GSM Phase 2) R96 (Release 1996) R97 (Release 1997) R98 (Release 1998) R99 (Release 1999) Rel-4 (Release 4) Rel-5 (Release 5) Rel-6 (Release 6)

<b>Reason for change:</b>	Explanation about the use of the sequence number		
<b>Summary of change:</b>	The sequence number in the ULIC header in some scenarios (e.g. RAU) is not continuous and not unique. By explicitly mentioning this fact in the specification LEMF manufacturers when reordering IP packets will take into account that deficiency.		
<b>Consequences if not approved:</b>	LEMF manufacturer may base implementation on the assumption that the sequence number is unique and continuous		

<b>Clauses affected:</b>	Annex C.1.2 and C.1.3										
<b>Other specs affected:</b>	<table border="1" style="display: inline-table; border-collapse: collapse;"> <tr> <td style="width: 20px; text-align: center;">Y</td> <td style="width: 20px; text-align: center;">N</td> </tr> <tr> <td style="text-align: center;"><input type="checkbox"/></td> <td style="text-align: center;"><input checked="" type="checkbox"/></td> </tr> <tr> <td style="text-align: center;"><input type="checkbox"/></td> <td style="text-align: center;"><input checked="" type="checkbox"/></td> </tr> <tr> <td style="text-align: center;"><input type="checkbox"/></td> <td style="text-align: center;"><input checked="" type="checkbox"/></td> </tr> </table>	Y	N	<input type="checkbox"/>	<input checked="" type="checkbox"/>	<input type="checkbox"/>	<input checked="" type="checkbox"/>	<input type="checkbox"/>	<input checked="" type="checkbox"/>	Other core specifications Test specifications O&M Specifications	
Y	N										
<input type="checkbox"/>	<input checked="" type="checkbox"/>										
<input type="checkbox"/>	<input checked="" type="checkbox"/>										
<input type="checkbox"/>	<input checked="" type="checkbox"/>										
<b>Other comments:</b>											

**\*\*\*\* Changes \*\*\*\***

### C.1.2 Definition of ULIC header version 0

ULIC header contains the following attributes:

- Correlation Number.
- Message Type (a value of 255 is used for HI3-PDU's).
- Direction.
- Sequence Number.
- Length.

T-PDU contains the intercepted information.

Octets	Bits							
	8	7	6	5	4	3	2	1
1	Version ('0 0 0')		'1'	Spare '1 1'		DIR	'0'	
2	Message Type (value 255)							
3-4	Length							
5-6	Sequence Number							
7-8	not used (value 0)							
9	not used (value 255)							
10	not used (value 255)							
11	not used (value 255)							
12	not used (value 255)							
13-20	correlation number							

**Figure C.1: Outline of ULIC header**

For interception tunneling the ULIC header shall be used as follows:

- Version shall be set to 0 to indicate the first version of ULIC header.
- DIR indicates the direction of the T-PDU:
  - "1" indicating uplink (from observed mobile user); and
  - "0" indicating downlink (to observed mobile user).
- Message Type shall be set to 255 (the unique value that is used for T-PDU within GTP [12]).
- Length shall be the length, in octets, of the signalling message excluding the ULIC header. Bit 8 of octet 3 is the most significant bit and bit 1 of octet 4 is the least significant bit of the length field.
- Sequence Number is an increasing sequence number for tunneled T-PDUs. Bit 8 of octet 5 is the most significant bit and bit 1 of octet 6 is the least significant bit of the sequence number field.

[NOTE: When a handoff occurs between SGSNs, the DF3 serving the LEA may change. If the DF3 serving an LEA changes as a result of an handoff between SGSNs, contiguous sequencing may not occur as new sequencing may be initiated at the new DF3. Accordingly, the LEA should not assume that sequencing shall be contiguous when handoff occurs between SGSNs and the DF3 serving the LEA changes.](#)

- Correlation Number consists of two parts: GGSN-ID identifies the GGSN which creates the Charging-ID. Charging-ID is defined in [12] and assigned uniquely to each PDP context activation on that GGSN (4 octets).

The correlation number consist of 8 octets. The requirements for this correlation number are similar to that defined for charging in [12], chapter 5.4. Therefore it is proposed to use the Charging-ID, defined in [12] ,

chapter 5.4 as part of correlation number. The Charging-ID is signaled to the new SGSN in case of SGSN-change so the tunnel identifier could be used "seamlessly" for the HI3 interface.

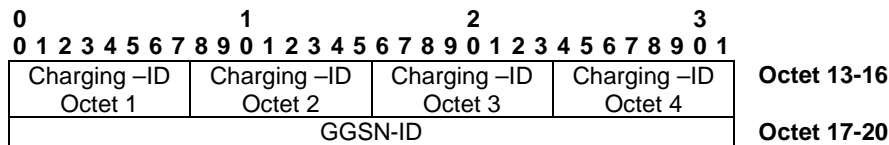

**Figure C.2: Outline of correlation number**

The ULIC header is followed by a subsequent payload information element. Only one payload information element is allowed in a single ULIC message.

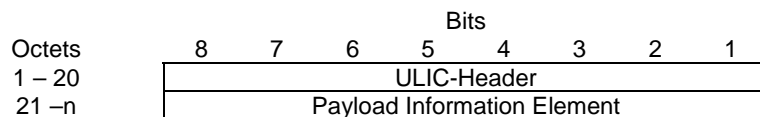

**Figure C.3: ULIC header followed by the subsequent payload Information Element**

The payload information element contains the header and the payload of the communication between the intercepted subscriber and the other party.

### C.1.3 Definition of ULIC header version 1

ULIC-header version 1 is defined in ASN.1 [5] (see annex B.4) and is encoded according to BER [6]. It contains the following attributes:

- Object Identifier (hi3DomainId)
- ULIC header version (version) set to version1.
- lawful interception identifier (IIID, optional) sending of lawful interception identifier is application dependant; it is done according to national requirements.
- correlation number (correlation-Number). As defined in clause 6.1.3
- time stamp (timeStamp, optional), sending of time stamp is application dependant; it is done according to national requirements.
- sequence number (sequence-number). Sequence Number is an increasing sequence number for tunneled T-PDUs. Handling of sequence number is application dependent; it is done according to national requirements (e.g. unique sequence number per PDP-context).

NOTE: When a handoff occurs between SGSNs, the DF3 serving the LEA may change. If the DF3 serving an LEA changes as a result of an handoff between SGSNs, contiguous sequencing may not occur as new sequencing may be initiated at the new DF3. Accordingly, the LEA should not assume that sequencing shall be contiguous when handoff occurs between SGSNs and the DF3 serving the LEA changes.

- TPDU direction (t-PDU-direction) indicates the direction of the T-PDU (from the target or to the target).

The ULIC header is followed by a subsequent payload information element. Only one payload information element is allowed in a single ULIC message (see annex B.4).

The payload information element contains the header and the payload of the communication between the intercepted subscriber and the other party.

## CHANGE REQUEST

⌘ **33.108 CR 051** ⌘ rev **-** ⌘ Current version: **6.6.0** ⌘

For **HELP** on using this form, see bottom of this page or look at the pop-up text over the ⌘ symbols.

Proposed change affects: | UICC apps  ME  Radio Access Network  Core Network

<b>Title:</b>	<span>⌘</span> National ASN.1 parameter		
<b>Source:</b>	<span>⌘</span> SA WG3 (LI Group)		
<b>Work item code:</b>	<span>⌘</span> SEC1-LI	<b>Date:</b>	<span>⌘</span> 20/07/2004
<b>Category:</b>	<span>⌘</span> <b>B</b>	<b>Release:</b>	<span>⌘</span> Rel-6
	Use <u>one</u> of the following categories: <b>F</b> (correction) <b>A</b> (corresponds to a correction in an earlier release) <b>B</b> (addition of feature), <b>C</b> (functional modification of feature) <b>D</b> (editorial modification) Detailed explanations of the above categories can be found in 3GPP <a href="#">TR 21.900</a> .		Use <u>one</u> of the following releases: 2 (GSM Phase 2) R96 (Release 1996) R97 (Release 1997) R98 (Release 1998) R99 (Release 1999) Rel-4 (Release 4) Rel-5 (Release 5) Rel-6 (Release 6)

<b>Reason for change:</b>	<span>⌘</span> Introduction of ASN.1 type for national parameters integrated into the 3GPP module
<b>Summary of change:</b>	<span>⌘</span> ETSI TC LI has introduced an ASN.1 type for national parameters which allows a one step encoding and decoding (see 05litd045r2 and 05litd048r2. This method offers a more efficient way of including national parameters into the IRI.
<b>Consequences if not approved:</b>	<span>⌘</span> For encoding and decoding, an increased effort is required when the currently defined container for national parameters would be used.

<b>Clauses affected:</b>	<span>⌘</span> Annex B.3 and annex B.3a						
<b>Other specs affected:</b>	<table border="1" style="display: inline-table; border-collapse: collapse;"> <tr> <td style="width: 20px; text-align: center;">Y</td> <td style="width: 20px; text-align: center;">N</td> </tr> <tr> <td style="text-align: center;"><input type="checkbox"/></td> <td style="text-align: center;"><input checked="" type="checkbox"/></td> </tr> </table> Other core specifications <span>⌘</span>	Y	N	<input type="checkbox"/>	<input checked="" type="checkbox"/>		
Y	N						
<input type="checkbox"/>	<input checked="" type="checkbox"/>						
	<table border="1" style="display: inline-table; border-collapse: collapse;"> <tr> <td style="width: 20px; text-align: center;">X</td> </tr> <tr> <td style="text-align: center;"><input checked="" type="checkbox"/></td> </tr> </table> Test specifications	X	<input checked="" type="checkbox"/>				
X							
<input checked="" type="checkbox"/>							
	<table border="1" style="display: inline-table; border-collapse: collapse;"> <tr> <td style="width: 20px; text-align: center;">X</td> </tr> <tr> <td style="text-align: center;"><input checked="" type="checkbox"/></td> </tr> </table> O&M Specifications	X	<input checked="" type="checkbox"/>				
X							
<input checked="" type="checkbox"/>							
<b>Other comments:</b>	<span>⌘</span>						

**\*\*\*\* Changes \*\*\*\***

## B.3 Intercept related information (HI2)

Declaration of ROSE operation umts-sending-of-IRI is ROSE delivery mechanism specific. When using FTP delivery mechanism, data UmtsIRIsContent must be considered.

### ASN1 description of IRI (HI2 interface)

```
UmtsHI2Operations {itu-t(0) identified-organization(4) etsi(0) securityDomain(2) lawfulIntercept(2)
threeGPP(4) hi2(1) r6(6) version-45(45)}
```

```
DEFINITIONS IMPLICIT TAGS ::=
```

```
BEGIN
```

```
IMPORTS
```

```
OPERATION,
ERROR
```

```
FROM Remote-Operations-Information-Objects
{joint-iso-itu-t(2) remote-operations(4) informationObjects(5) version1(0)}
```

```
LawfulInterceptionIdentifier,
TimeStamp,
Network-Identifier,
National-Parameters,
National-HI2-ASN1parameters,
DataNodeAddress,
IPAddress,
IP-value,
X25Address
```

```
FROM HI2Operations
{itu-t(0) identified-organization(4) etsi(0) securityDomain(2)
lawfulIntercept(2) hi2(1) version5(5)}; -- Imported from TS 101 671
```

```
-- Object Identifier Definitions
```

```
-- Security DomainId
lawfulInterceptDomainId OBJECT IDENTIFIER ::= {itu-t(0) identified-organization(4) etsi(0)
securityDomain(2) lawfulIntercept(2)}
```

```
-- Security Subdomains
```

```
threeGPPSUBDomainId OBJECT IDENTIFIER ::= {lawfulInterceptDomainId threeGPP(4)}
hi2DomainId OBJECT IDENTIFIER ::= {threeGPPSUBDomainId hi2(1) r6(6) version-45(45)}
```

```
umts-sending-of-IRI OPERATION ::=
```

```
{
  ARGUMENT      UmtsIRIsContent
  ERRORS        { OperationErrors }
  CODE          global:{threeGPPSUBDomainId hi2(1) opcode(1)}
}
```

```
-- Class 2 operation . The timer shall be set to a value between 3 s and 240 s.
```

```
-- The timer.default value is 60s.
```

```
-- NOTE: The same note as for HI management operation applies.
```

```
UmtsIRIsContent ::= CHOICE
```

```
{
  umtsIRIContent      UmtsIRIContent,
  umtsIRISequence     UmtsIRISequence
}
```

```
UmtsIRISequence ::= SEQUENCE OF UmtsIRIContent
```

```
-- Aggregation of UmtsIRIContent is an optional feature.
```

```
-- It may be applied in cases when at a given point in time
```

```
-- several IRI records are available for delivery to the same LEA destination.
```

```
-- As a general rule, records created at any event shall be sent
```

```
-- immediately and not withheld in the DF or MF in order to
```

```
-- apply aggregation.
```

```
-- When aggregation is not to be applied,
-- UmtsIRIContent needs to be chosen.
```

```
UmtsIRIContent ::= CHOICE
{
  iRI-Begin-record [1] IRI-Parameters, -- include at least one optional parameter
  iRI-End-record [2] IRI-Parameters,
  iRI-Continue-record [3] IRI-Parameters, -- include at least one optional parameter
  iRI-Report-record [4] IRI-Parameters -- include at least one optional parameter
}
```

```
unknown-version ERROR ::= { CODE local:0}
missing-parameter ERROR ::= { CODE local:1}
unknown-parameter-value ERROR ::= { CODE local:2}
unknown-parameter ERROR ::= { CODE local:3}
```

```
OperationErrors ERROR ::=
```

```
{
  unknown-version |
  missing-parameter |
  unknown-parameter-value |
  unknown-parameter
}
```

```
-- This values may be sent by the LEMF, when an operation or a parameter is misunderstood.
```

```
-- Parameters having the same tag numbers must be identical in Rel-5 and Rel-6 modules.
```

```
IRI-Parameters ::= SEQUENCE
```

```
{
  hi2DomainId [0] OBJECT IDENTIFIER, -- 3GPP HI2 domain
  iRIversion [23] ENUMERATED
  {
    version2 (2),
    ...,
    version3 (3),
    version4 (4)
  } OPTIONAL,
  -- if not present, it means version 1 is handled
  lawfulInterceptionIdentifier [1] LawfulInterceptionIdentifier,
  -- This identifier is associated to the target.
  timeStamp [3] TimeStamp,
  -- date and time of the event triggering the report.)
  initiator [4] ENUMERATED
  {
    not-Available (0),
    originating-Target (1),
    -- in case of GPRS, this indicates that the PDP context activation, modification
    -- or deactivation is MS requested
    terminating-Target (2),
    -- in case of GPRS, this indicates that the PDP context activation, modification or
    -- deactivation is network initiated
    ...
  } OPTIONAL,

  locationOfTheTarget [8] Location OPTIONAL,
  -- location of the target subscriber
  partyInformation [9] SET SIZE (1..10) OF PartyInformation OPTIONAL,
  -- This parameter provides the concerned party, the identiy(ies) of the party
  --)and all the information provided by the party.

  serviceCenterAddress [13] PartyInformation OPTIONAL,
  -- e.g. in case of SMS message this parameter provides the address of the relevant
  -- server within the calling (if server is originating) or called (if server is
  -- terminating) party address parameters
  sms [14] SMS-report OPTIONAL,
  -- this parameter provides the SMS content and associated information

  national-Parameters [16] National-Parameters OPTIONAL,
  gPRSCorrelationNumber [18] GPRSCorrelationNumber OPTIONAL,
  gPRSevent [20] GPRSEvent OPTIONAL,
  -- This information is used to provide particular action of the target
  -- such as attach/detach
  sgsnAddress [21] DataNodeAddress OPTIONAL,
  gPRSOperationErrorCode [22] GPRSOperationErrorCode OPTIONAL,
  ggsnAddress [24] DataNodeAddress OPTIONAL,
  qos [25] UmtsQos OPTIONAL,
  networkIdentifier [26] Network-Identifier OPTIONAL,
```

```

smsOriginatingAddress [27] DataNodeAddress OPTIONAL,
smsTerminatingAddress [28] DataNodeAddress OPTIONAL,
imSevent [29] IMSevent OPTIONAL,
sipMessage [30] OCTET STRING OPTIONAL,
servingsGSN-number [31] OCTET STRING (SIZE (1..20)) OPTIONAL,
servingsGSN-address [32] OCTET STRING (SIZE (5..17)) OPTIONAL,
-- Octets are coded according to 3GPP TS 23.003 [25]
...

```

```

national-HI2-ASN1parameters [255] National-HI2-ASN1parameters OPTIONAL

```

```

}
-- Parameters having the same tag numbers must be identical in Rel-5 and Rel-6 modules

```

```

-- PARAMETERS FORMATS

```

```

PartyInformation ::= SEQUENCE
{
  party-Qualifier [0] ENUMERATED
  {
    gPRS-Target(3),
    ...
  },
  partyIdentity [1] SEQUENCE
  {
    imei [1] OCTET STRING (SIZE (8)) OPTIONAL,
    -- See MAP format [4]

    imsi [3] OCTET STRING (SIZE (3..8)) OPTIONAL,
    -- See MAP format [4] International Mobile
    -- Station Identity E.212 number beginning with Mobile Country Code

    msISDN [6] OCTET STRING (SIZE (1..9)) OPTIONAL,
    -- MSISDN of the target, encoded in the same format as the AddressString
    -- parameters defined in MAP format document [4], § 14.7.8

    e164-Format [7] OCTET STRING (SIZE (1 .. 25)) OPTIONAL,
    -- E164 address of the node in international format. Coded in the same format as
    -- the calling party number parameter of the ISUP (parameter part:[5])

    sip-url [8] OCTET STRING OPTIONAL,
    -- See [26]

    ...,
    tel-url [9] OCTET STRING OPTIONAL,
    -- See [36]
  },

  services-Data-Information [4] Services-Data-Information OPTIONAL,
  -- This parameter is used to transmit all the information concerning the
  -- complementary information associated to the basic data call
  ...
}

```

```

Location ::= SEQUENCE
{
  globalCellID [2] GlobalCellID OPTIONAL,
  --see MAP format (see [4])

  rAI [4] Rai OPTIONAL,
  -- the Routing Area Identifier is coded in accordance with the § 10.5.5.15 of
  -- document [9] without the Routing Area Identification IEI (only the
  -- last 6 octets are used)

  gsmLocation [5] GSMLocation OPTIONAL,
  umtsLocation [6] UMTSLocation OPTIONAL,
  sAI [7] Sai OPTIONAL,
  -- format: PLMN-ID 3 octets (no. 1 - 3)
  -- LAC 2 octets (no. 4 - 5)
  -- SAC 2 octets (no. 6 - 7)
  -- (according to 3GPP TS 25.413)
  ...
}

```

```

GlobalCellID ::= OCTET STRING (SIZE (5..7))
Rai ::= OCTET STRING (SIZE (6))
Sai ::= OCTET STRING (SIZE (7))

```

```

GSMLocation ::= CHOICE
{

```



```

geoCoordinates [1] SEQUENCE
{
  latitude [1] PrintableString (SIZE(7..10)),
    -- format : XDDMMSS.SS
  longitude [2] PrintableString (SIZE(8..11)),
    -- format : XDDMMSS.SS
  mapDatum [3] MapDatum DEFAULT WGS84,
  ...
},
-- format : XDDMMSS.SS
-- X : N(orth), S(outh), E(ast), W(est)
-- DD or DDD : degrees (numeric characters)
-- MM : minutes (numeric characters)
-- SS.SS : seconds, the second part (.SS) is optional
-- Example :
-- latitude short form N502312
-- longitude long form E1122312.18

utmCoordinates [2] SEQUENCE
{
  utm-East [1] PrintableString (SIZE(10)),
  utm-North [2] PrintableString (SIZE(7)),
  -- example utm-East 32U0439955
  -- utm-North 5540736
  mapDatum [3] MapDatum DEFAULT WGS84,
  ...
},

utmRefCoordinates [3] SEQUENCE
{
  utmref-string PrintableString (SIZE(13)),
  mapDatum MapDatum DEFAULT WGS84,
  ...
},
-- example 32UPU91294045

wGS84Coordinates [4] OCTET STRING
  -- format is as defined in [37]; polygon type of shape is not allowed.
}

MapDatum ::= ENUMERATED
{
  wGS84,
  wGS72,
  eD50, -- European Datum 50
  ...
}

```

```

UMTSLocation ::= CHOICE {
  point [1] GA-Point,
  pointWithUnCertainty [2] GA-PointWithUnCertainty,
  polygon [3] GA-Polygon
}

```

```

GeographicalCoordinates ::= SEQUENCE {
  latitudeSign ENUMERATED { north, south },
  latitude INTEGER (0..8388607),
  longitude INTEGER (-8388608..8388607),
  ...
}

```

```

GA-Point ::= SEQUENCE {
  geographicalCoordinates GeographicalCoordinates,
  ...
}

```

```

GA-PointWithUnCertainty ::= SEQUENCE {
  geographicalCoordinates GeographicalCoordinates,
  uncertaintyCode INTEGER (0..127)
}

```

```

maxNrOfPoints INTEGER ::= 15

```

```

GA-Polygon ::= SEQUENCE (SIZE (1..maxNrOfPoints)) OF
  SEQUENCE {
    geographicalCoordinates GeographicalCoordinates,

```

```

} ...

```

```

SMS-report ::= SEQUENCE
{
  SMS-Contents [3] SEQUENCE
  {
    sms-initiator [1] ENUMERATED -- party which sent the SMS
    {
      target (0),
      server (1),
      undefined-party (2),
      ...
    },
    transfer-status [2] ENUMERATED
    {
      succeed-transfer (0), -- the transfer of the SMS message succeeds
      not-succeed-transfer (1),
      undefined (2),
      ...
    } OPTIONAL,
    other-message [3] ENUMERATED -- in case of terminating call, indicates if
    -- the server will send other SMS
    {
      yes (0),
      no (1),
      undefined (2),
      ...
    } OPTIONAL,
    content [4] OCTET STRING (SIZE (1 .. 270)) OPTIONAL,
    -- Encoded in the format defined for the SMS mobile
    ...
  }
}

```

```

GPRSCorrelationNumber ::= OCTET STRING (SIZE(8..20))

```

```

GPRSEvent ::= ENUMERATED
{
  pDPContextActivation (1),
  startOfInterceptionWithPDPContextActive (2),
  pDPContextDeactivation (4),
  gPRSAttach (5),
  gPRSDetach (6),
  locationInfoUpdate (10),
  sMS (11),
  pDPContextModification (13),
  servingSystem (14),
  ...
}
-- see ref [10]

```

```

IMSevent ::= ENUMERATED
{
  sIPmessage (1),
  ...
}

```

```

Services-Data-Information ::= SEQUENCE
{
  gPRS-parameters [1] GPRS-parameters OPTIONAL,
  ...
}

```

```

GPRS-parameters ::= SEQUENCE
{
  pDP-address-allocated-to-the-target [1] DataNodeAddress OPTIONAL,
  aPN [2] OCTET STRING (SIZE(1..100)) OPTIONAL,
  pDP-type [3] OCTET STRING (SIZE(2)) OPTIONAL,
  ...
}

```

```

GPRSOperationErrorCode ::= OCTET STRING (SIZE(2))
-- refer to standard [9] for values(GMM cause or SM cause parameter).

```

```

UmtsQos ::= CHOICE

```

```
{
  qosMobileRadio [1] OCTET STRING,
    -- The qosMobileRadio parameter shall be coded in accordance with the § 10.5.6.5 of
    -- document [9] or [21] without the Quality of service IEI and Length of
    -- quality of service IE (. That is, first
    -- two octets carrying 'Quality of service IEI' and 'Length of quality of service
    -- IE' shall be excluded).
  qosGn [2] OCTET STRING
    -- qosGn parameter shall be coded in accordance with § 7.7.34 of document [17]
}
```

END -- OF UmtsHI2Operations

## B.3a Interception related information (HI2 CS)

For North America the use of J-STD-25 A[23] is recommended.

Declaration of ROSE operation sending-of-IRI is ROSE delivery mechanism specific. When using FTP delivery mechanism, data IRI-Content must be considered.

### ASN1 description of IRI (HI2 CS interface)

```
UmtsCS-HI2Operations
{ itu-t (0) identified-organization (4) etsi (0) securityDomain (2) lawfulIntercept (2) threeGPP(4)
hi2CS (3) version-2 (2)}
```

DEFINITIONS IMPLICIT TAGS ::=

BEGIN

```
IMPORTS OPERATION,
  ERROR
  FROM Remote-Operations-Information-Objects
  {joint-iso-itu-t (2) remote-operations(4) informationObjects(5) version1(0)}

  LawfulInterceptionIdentifier,
  TimeStamp,
  Intercepted-Call-State,
  PartyInformation,
  CallContentLinkCharacteristics,
  CommunicationIdentifier,
  CC-Link-Identifier,
  National-Parameters,
  National-HI2-ASN1parameters,

  FROM HI2Operations
  {itu-t(0) identified-organization(4) etsi(0) securityDomain(2)
  lawfulIntercept(2) hi2(1) version5(5)} -- Imported from TS 101 671 ASN.1

  Location,
  SMS-report

  FROM UmtsHI2Operations
  {itu-t(0) identified-organization(4) etsi(0) securityDomain(2)
  lawfulintercept(2) threeGPP(4) hi2(1) r6(6) version-4(4)};

-- Object Identifier Definitions

-- Security DomainId
lawfulInterceptDomainId OBJECT IDENTIFIER ::= {itu-t(0) identified-organization(4) etsi(0)
securityDomain(2) lawfulIntercept(2)}

-- Security Subdomains
threeGPPSUBDomainId OBJECT IDENTIFIER ::= {lawfulInterceptDomainId threeGPP(4)}
hi2CSDomainId OBJECT IDENTIFIER ::= {threeGPPSUBDomainId hi2CS(3) version-2(2)}
```

**umtsCS-sending-of-IRI** OPERATION ::=

```
{
  ARGUMENT    UmtsCS-IRIsContent
  ERRORS      { OperationErrors }
  CODE        global:{ threeGPPSUBDomainID hi2CS(3) opcode(1)}
}
-- Class 2 operation. The timer shall be set to a value between 3 s and 240 s.
-- The timer.default value is 60s.
-- NOTE: The same note as for HI management operation applies.
```

**UmtsCS-IRIsContent** ::= CHOICE

```
{
  iRIContent      UmtsCS-IRIContent,
  iRISequence     UmtsCS-IRISequence
}
```

```

UmtsCS-IRISequence ::= SEQUENCE OF UmtsCS-IRIContent
-- Aggregation of UmtsCS-IRIContent is an optional feature.
-- It may be applied in cases when at a given point in time several IRI records are
-- available for delivery to the same LEA destination.
-- As a general rule, records created at any event shall be sent immediately and shall
-- not held in the DF or MF in order to apply aggregation.
-- When aggregation is not to be applied, UmtsCS-IRIContent needs to be chosen.

UmtsCS-IRIContent ::= CHOICE
{
  iRI-Begin-record [1] IRI-Parameters,
  --at least one optional parameter must be included within the iRI-Begin-Record
  iRI-End-record [2] IRI-Parameters,
  iRI-Continue-record [3] IRI-Parameters,
  --at least one optional parameter must be included within the iRI-Continue-Record
  iRI-Report-record [4] IRI-Parameters,
  --at least one optional parameter must be included within the iRI-Report-Record
  ...
}

```

```

unknown-version          ERROR ::= { CODE local:0}
missing-parameter       ERROR ::= { CODE local:1}
unknown-parameter-value ERROR ::= { CODE local:2}
unknown-parameter       ERROR ::= { CODE local:3}

```

```

OperationErrors ERROR ::=

```

```

{
  unknown-version |
  missing-parameter |
  unknown-parameter-value |
  unknown-parameter
}

```

```

--These values may be sent by the LEMF, when an operation or a parameter is misunderstood.

```

```

IRI-Parameters ::= SEQUENCE
{
  hi2CSDomainId [0] OBJECT IDENTIFIER OPTIONAL, -- 3GPP HI2 CS domain

  iRIversion [23] ENUMERATED
  {
    version1(1),
    ...,
    version2(2)
  } OPTIONAL,
  -- if not present, it means version 1 is handled
  lawfulInterceptionIdentifier [1] LawfulInterceptionIdentifier,
  -- This identifier is associated to the target.
  communicationIdentifier [2] CommunicationIdentifier,
  -- used to uniquely identify an intercepted call.

  timeStamp [3] TimeStamp,
  -- date and time of the event triggering the report.
  intercepted-Call-Direct [4] ENUMERATED
  {
    not-Available(0),
    originating-Target(1),
    terminating-Target(2),
    ...
  } OPTIONAL,
  intercepted-Call-State [5] Intercepted-Call-State OPTIONAL,
  -- Not required for UMTS. May be included for backwards compatibility to GSM
  ringingDuration [6] OCTET STRING (SIZE (3)) OPTIONAL,
  -- Duration in seconds. BCD coded : HHMMSS
}

```

```

-- Not required for UMTS. May be included for backwards compatibility to GSM
conversationDuration [7] OCTET STRING (SIZE (3)) OPTIONAL,
-- Duration in seconds. BCD coded : HHMMSS
-- Not required for UMTS. May be included for backwards compatibility to GSM
locationOfTheTarget [8] Location OPTIONAL,
-- location of the target subscriber
partyInformation [9] SET SIZE (1..10) OF PartyInformation OPTIONAL,
-- This parameter provides the concerned party (Originating, Terminating or forwarded
-- party), the identity(ies) of the party and all the information provided by the party.
callContentLinkInformation [10] SEQUENCE
{
  cCLink1Characteristics [1] CallContentLinkCharacteristics OPTIONAL,
  -- information concerning the Content of Communication Link Tx channel established
  -- toward the LEMF (or the sum signal channel, in case of mono mode).
  cCLink2Characteristics [2] CallContentLinkCharacteristics OPTIONAL,
  -- information concerning the Content of Communication Link Rx channel established
  -- toward the LEMF.
  ...
} OPTIONAL,
release-Reason-Of-Intercepted-Call [11] OCTET STRING (SIZE (2)) OPTIONAL,
-- Release cause coded in [31] format.
-- This parameter indicates the reason why the
-- intercepted call cannot be established or why the intercepted call has been
-- released after the active phase.
nature-Of-The-intercepted-call [12] ENUMERATED
{
  --Not required for UMTS. May be included for backwards compatibility to GSM
  --Nature of the intercepted "call":
  gSM-ISDN-PSTN-circuit-call(0),
  -- the possible UUS content is sent through the HI2 or HI3 "data" interface
  -- the possible call content call is established through the HI3 „circuit„ interface
  gSM-SMS-Message(1),
  -- the SMS content is sent through the HI2 or HI3 "data" interface
  uUS4-Messages(2),
  -- the UUS content is sent through the HI2 or HI3 "data" interface
  tETRA-circuit-call(3),
  -- the possible call content call is established through the HI3 "circuit" interface
  -- the possible data are sent through the HI3 "data" interface
  teTRA-Packet-Data(4),
  -- the data are sent through the HI3 "data" interface
  gPRS-Packet-Data(5),
  -- the data are sent through the HI3 "data" interface
  ...
} OPTIONAL,
serviceCenterAddress [13] PartyInformation OPTIONAL,
-- e.g. in case of SMS message this parameter provides the address of the relevant
-- server within the calling (if server is originating) or called
-- (if server is terminating) party address parameters
sMS [14] SMS-report OPTIONAL,
-- this parameter provides the SMS content and associated information
cC-Link-Identifier [15] CC-Link-Identifier OPTIONAL,
-- Depending on a network option, this parameter may be used to identify a CC link
-- in case of multiparty calls.
national-Parameters [16] National-Parameters OPTIONAL,
...
umts-Cs-Event [33] Umts-Cs-Event OPTIONAL,
-- Care should be taken to ensure additional parameter numbering does not conflict with
-- ETSI TS 101 671 or Annex B.3 of this document (PS HI2).
national-HI2-ASN1parameters [255] National-HI2-ASN1parameters OPTIONAL

```

```

}
Umts-Cs-Event ::= ENUMERATED
{
  call-establishment (1),
  answer (2),
  supplementary-Service (3),
  handover (4),
  release (5),
  sMS (6),
  location-update (7),
  subscriber-Controlled-Input (8),
  ...
}

```

END - OF UmtsCS-HI2Operations



## CHANGE REQUEST

**33.108 CR 052** rev - Current version: **6.6.0**

For **HELP** on using this form, see bottom of this page or look at the pop-up text over the symbols.

**Proposed change affects:**  UICC apps  ME  Radio Access Network  Core Network

<b>Title:</b>	Clarifying clause titles		
<b>Source:</b>	SA WG3 (LI Group)		
<b>Work item code:</b>	SEC-LI	<b>Date:</b>	20.06.2004
<b>Category:</b>	<b>D</b>	<b>Release:</b>	Rel-6
	Use <u>one</u> of the following categories: <b>F</b> (correction) <b>A</b> (corresponds to a correction in an earlier release) <b>B</b> (addition of feature), <b>C</b> (functional modification of feature) <b>D</b> (editorial modification) Detailed explanations of the above categories can be found in 3GPP <a href="#">TR 21.900</a> .		Use <u>one</u> of the following releases: 2 (GSM Phase 2) R96 (Release 1996) R97 (Release 1997) R98 (Release 1998) R99 (Release 1999) Rel-4 (Release 4) Rel-5 (Release 5) Rel-6 (Release 6)

<b>Reason for change:</b>	Some of the subclause titles under Annex B are not completely clear. Some of them are misaligned: <ul style="list-style-type: none"> <li>• B3 and B3a</li> <li>• B4 and B6</li> </ul> This CR offers clear cut and aligned titles for the subclauses B3, B4, B5 and B6. Companion CR to ETSI TS 101 671 is in '06ltd013'. Taking into account LS from T1P1.5, it is proposed to clarify the title of Annex H as well.
<b>Summary of change:</b>	CR offers clear cut and aligned titles for the subclauses B3, B4, B5, B6 and Annex H.
<b>Consequences if not approved:</b>	Ambiguity, which may lead to multiple interpretations.

<b>Clauses affected:</b>	B3, B4, B5 B6, and H.						
<b>Other specs affected:</b>	<table border="1" style="display: inline-table; border-collapse: collapse;"> <tr> <td style="width: 20px;">Y</td> <td style="width: 20px;">N</td> </tr> <tr> <td style="text-align: center;"><input type="checkbox"/></td> <td style="text-align: center;"><input checked="" type="checkbox"/></td> </tr> </table> Other core specifications	Y	N	<input type="checkbox"/>	<input checked="" type="checkbox"/>		
Y	N						
<input type="checkbox"/>	<input checked="" type="checkbox"/>						
	<table border="1" style="display: inline-table; border-collapse: collapse;"> <tr> <td style="width: 20px;">X</td> </tr> <tr> <td style="text-align: center;"><input checked="" type="checkbox"/></td> </tr> </table> Test specifications	X	<input checked="" type="checkbox"/>				
X							
<input checked="" type="checkbox"/>							
	<table border="1" style="display: inline-table; border-collapse: collapse;"> <tr> <td style="width: 20px;">X</td> </tr> <tr> <td style="text-align: center;"><input checked="" type="checkbox"/></td> </tr> </table> O&M Specifications	X	<input checked="" type="checkbox"/>				
X							
<input checked="" type="checkbox"/>							
<b>Other comments:</b>							



---

B.3 Intercept related information (HI2 [PS and IMS](#))

\*\*\* Next Modification \*\*\*

B.4 [Contents of communication](#) ~~HI3 CC definition~~ [\(HI3 PS\)](#)

\*\*\* Next Modification \*\*\*

---

B.5 HI management operation [\(HI1 PS and CS using HI2 method\)](#)

\*\*\* Next Modification \*\*\*

---

B.6 User data packet transfer (HI3 [CS](#))

\*\*\* Next Modification \*\*\*

---

Annex H (normative):

United States lawful interception [\(PS domain and IMS\)](#)

## CHANGE REQUEST

**33.108 CR 053** rev - Current version: **6.6.0**

For **HELP** on using this form, see bottom of this page or look at the pop-up text over the symbols.

**Proposed change affects:** | UICC apps  ME  Radio Access Network  Core Network

<b>Title:</b>	Adding azimuth in location		
<b>Source:</b>	PIDS		
<b>Work item code:</b>	SEC1-LI	<b>Date:</b>	20/07/2004
<b>Category:</b>	<b>B</b>	<b>Release:</b>	Rel-6
	Use <u>one</u> of the following categories: <b>F</b> (correction) <b>A</b> (corresponds to a correction in an earlier release) <b>B</b> (addition of feature), <b>C</b> (functional modification of feature) <b>D</b> (editorial modification) Detailed explanations of the above categories can be found in 3GPP <a href="#">TR 21.900</a> .		Use <u>one</u> of the following releases: 2 (GSM Phase 2) R96 (Release 1996) R97 (Release 1997) R98 (Release 1998) R99 (Release 1999) Rel-4 (Release 4) Rel-5 (Release 5) Rel-6 (Release 6)

<b>Reason for change:</b>	Alignment with ETSI 101 671
<b>Summary of change:</b>	Networks can operate more radio cells from one radio site. If geographical coordinates can only indicate the location of a radio site. The azimuth is needed to address also the cell.
<b>Consequences if not approved:</b>	Providers will not be able to indicate the individual cell location when using geographical coordinates.

<b>Clauses affected:</b>	Annex B.3				
<b>Other specs affected:</b>	<table border="1" style="display: inline-table; vertical-align: middle;"> <tr> <td style="width: 20px; text-align: center;">Y</td> <td style="width: 20px; text-align: center;">N</td> </tr> <tr> <td style="text-align: center;"><input type="checkbox"/></td> <td style="text-align: center;"><input checked="" type="checkbox"/></td> </tr> </table> Other core specifications <input checked="" type="checkbox"/>	Y	N	<input type="checkbox"/>	<input checked="" type="checkbox"/>
Y	N				
<input type="checkbox"/>	<input checked="" type="checkbox"/>				
	<table border="1" style="display: inline-table; vertical-align: middle;"> <tr> <td style="text-align: center;"><input checked="" type="checkbox"/></td> <td style="text-align: center;"><input checked="" type="checkbox"/></td> </tr> </table> Test specifications	<input checked="" type="checkbox"/>	<input checked="" type="checkbox"/>		
<input checked="" type="checkbox"/>	<input checked="" type="checkbox"/>				
	<table border="1" style="display: inline-table; vertical-align: middle;"> <tr> <td style="text-align: center;"><input checked="" type="checkbox"/></td> <td style="text-align: center;"><input checked="" type="checkbox"/></td> </tr> </table> O&M Specifications	<input checked="" type="checkbox"/>	<input checked="" type="checkbox"/>		
<input checked="" type="checkbox"/>	<input checked="" type="checkbox"/>				
<b>Other comments:</b>	ASN.1 version number to be checked and configured by editor!!				

\*\*\*\* **CHANGE** \*\*\*\*

## B.3 Intercept related information (HI2)

Declaration of ROSE operation umts-sending-of-IRI is ROSE delivery mechanism specific. When using FTP delivery mechanism, data UmtsIRIsContent must be considered.

### ASN1 description of IRI (HI2 interface)

```
UmtsHI2Operations {itu-t(0) identified-organization(4) etsi(0) securityDomain(2) lawfulIntercept(2)
threeGPP(4) hi2(1) r6(6) version-45(45)}
```

DEFINITIONS IMPLICIT TAGS ::=

BEGIN

IMPORTS

OPERATION,  
ERROR

FROM Remote-Operations-Information-Objects  
{joint-iso-itu-t(2) remote-operations(4) informationObjects(5) version1(0)}

LawfulInterceptionIdentifier,  
TimeStamp,  
Network-Identifier,  
National-Parameters,  
DataNodeAddress,  
IPAddress,  
IP-value,  
X25Address

FROM HI2Operations  
{itu-t(0) identified-organization(4) etsi(0) securityDomain(2)  
lawfulIntercept(2) hi2(1) version5(5)}; -- Imported from TS 101 671

-- Object Identifier Definitions

-- Security DomainId  
lawfulInterceptDomainId OBJECT IDENTIFIER ::= {itu-t(0) identified-organization(4) etsi(0)  
securityDomain(2) lawfulIntercept(2)}

-- Security Subdomains  
threeGPPSUBDomainId OBJECT IDENTIFIER ::= {lawfulInterceptDomainId threeGPP(4)}  
hi2DomainId OBJECT IDENTIFIER ::= {threeGPPSUBDomainId hi2(1) r6(6) version-54(54)}

**umts-sending-of-IRI** OPERATION ::=

```
{
  ARGUMENT    UmtsIRIsContent
  ERRORS      { OperationErrors }
  CODE        global:{threeGPPSUBDomainId hi2(1) opcode(1)}
}
```

-- Class 2 operation . The timer shall be set to a value between 3 s and 240 s.

-- The timer.default value is 60s.

-- NOTE: The same note as for HI management operation applies.

**UmtsIRIsContent** ::= CHOICE

```
{
  umtsIRIContent      UmtsIRIContent,
  umtsIRISequence     UmtsIRISequence
}
```

**UmtsIRISequence** ::= SEQUENCE OF UmtsIRIContent

-- Aggregation of **UmtsIRIContent** is an **optional** feature.  
-- It may be applied in cases when at a given point in time  
-- several IRI records are available for delivery to the same LEA destination.  
-- As a general rule, records created at any event shall be sent  
-- immediately and not withheld in the DF or MF in order to  
-- apply aggregation.  
-- When aggregation is not to be applied,

```
-- UmtsIRIContent needs to be chosen.
```

```
UmtsIRIContent ::= CHOICE
{
  iRI-Begin-record [1] IRI-Parameters, -- include at least one optional parameter
  iRI-End-record [2] IRI-Parameters,
  iRI-Continue-record [3] IRI-Parameters, -- include at least one optional parameter
  iRI-Report-record [4] IRI-Parameters -- include at least one optional parameter
}
```

```
unknown-version ERROR ::= { CODE local:0}
missing-parameter ERROR ::= { CODE local:1}
unknown-parameter-value ERROR ::= { CODE local:2}
unknown-parameter ERROR ::= { CODE local:3}
```

```
OperationErrors ERROR ::=
{
  unknown-version |
  missing-parameter |
  unknown-parameter-value |
  unknown-parameter
}
```

```
-- This values may be sent by the LEMF, when an operation or a parameter is misunderstood.
```

```
-- Parameters having the same tag numbers must be identical in Rel-5 and Rel-6 modules.
```

```
IRI-Parameters ::= SEQUENCE
{
  hi2DomainId [0] OBJECT IDENTIFIER, -- 3GPP HI2 domain
  iRIVersion [23] ENUMERATED
  {
    version2 (2),
    ...,
    version3 (3),
    version4 (4)
  } OPTIONAL,
  -- if not present, it means version 1 is handled
  lawfulInterceptionIdentifier [1] LawfulInterceptionIdentifier,
  -- This identifier is associated to the target.
  timeStamp [3] TimeStamp,
  -- date and time of the event triggering the report.)
  initiator [4] ENUMERATED
  {
    not-Available (0),
    originating-Target (1),
    -- in case of GPRS, this indicates that the PDP context activation, modification
    -- or deactivation is MS requested
    terminating-Target (2),
    -- in case of GPRS, this indicates that the PDP context activation, modification or
    -- deactivation is network initiated
    ...
  } OPTIONAL,

  locationOfTheTarget [8] Location OPTIONAL,
  -- location of the target subscriber
  partyInformation [9] SET SIZE (1..10) OF PartyInformation OPTIONAL,
  -- This parameter provides the concerned party, the identiy(ies) of the party
  --)and all the information provided by the party.

  serviceCenterAddress [13] PartyInformation OPTIONAL,
  -- e.g. in case of SMS message this parameter provides the address of the relevant
  -- server within the calling (if server is originating) or called (if server is
  -- terminating) party address parameters
  sMS [14] SMS-report OPTIONAL,
  -- this parameter provides the SMS content and associated information

  national-Parameters [16] National-Parameters OPTIONAL,
  gPRSCorrelationNumber [18] GPRSCorrelationNumber OPTIONAL,
  gPRSevent [20] GPRSEvent OPTIONAL,
  -- This information is used to provide particular action of the target
  -- such as attach/detach
  sgsnAddress [21] DataNodeAddress OPTIONAL,
  gPRSOperationErrorCode [22] GPRSOperationErrorCode OPTIONAL,
  ggsnAddress [24] DataNodeAddress OPTIONAL,
  qOS [25] UmtsQos OPTIONAL,
  networkIdentifier [26] Network-Identifier OPTIONAL,
  sMSOriginatingAddress [27] DataNodeAddress OPTIONAL,
```

```

smSTerminatingAddress [28] DataNodeAddress OPTIONAL,
imSevent [29] IMSevent OPTIONAL,
sIPMessage [30] OCTET STRING OPTIONAL,
servingSGSN-number [31] OCTET STRING (SIZE (1..20)) OPTIONAL,
servingSGSN-address [32] OCTET STRING (SIZE (5..17)) OPTIONAL,
-- Octets are coded according to 3GPP TS 23.003 [25]
...
}
-- Parameters having the same tag numbers must be identical in Rel-5 and Rel-6 modules

```

```
-- PARAMETERS FORMATS
```

```

PartyInformation ::= SEQUENCE
{
  party-Qualifier [0] ENUMERATED
  {
    gPRS-Target(3),
    ...
  },
  partyIdentity [1] SEQUENCE
  {
    imei [1] OCTET STRING (SIZE (8)) OPTIONAL,
    -- See MAP format [4]

    imsi [3] OCTET STRING (SIZE (3..8)) OPTIONAL,
    -- See MAP format [4] International Mobile
    -- Station Identity E.212 number beginning with Mobile Country Code

    msISDN [6] OCTET STRING (SIZE (1..9)) OPTIONAL,
    -- MSISDN of the target, encoded in the same format as the AddressString
    -- parameters defined in MAP format document [4], § 14.7.8

    e164-Format [7] OCTET STRING (SIZE (1..25)) OPTIONAL,
    -- E164 address of the node in international format. Coded in the same format as
    -- the calling party number parameter of the ISUP (parameter part:[5])

    sip-url [8] OCTET STRING OPTIONAL,
    -- See [26]

    ...,
    tel-url [9] OCTET STRING OPTIONAL,
    -- See [36]
  },
  services-Data-Information [4] Services-Data-Information OPTIONAL,
  -- This parameter is used to transmit all the information concerning the
  -- complementary information associated to the basic data call
  ...
}

```

```

Location ::= SEQUENCE
{
  globalCellID [2] GlobalCellID OPTIONAL,
  --see MAP format (see [4])
  rAI [4] Rai OPTIONAL,
  -- the Routeing Area Identifier is coded in accordance with the § 10.5.5.15 of
  -- document [9] without the Routing Area Identification IEI (only the
  -- last 6 octets are used)
  gsmLocation [5] GSMLocation OPTIONAL,
  umtsLocation [6] UMTSLocation OPTIONAL,
  sAI [7] Sai OPTIONAL,
  -- format: PLMN-ID 3 octets (no. 1 - 3)
  -- LAC 2 octets (no. 4 - 5)
  -- SAC 2 octets (no. 6 - 7)
  -- (according to 3GPP TS 25.413)
  ...
}

```

```

GlobalCellID ::= OCTET STRING (SIZE (5..7))
Rai ::= OCTET STRING (SIZE (6))
Sai ::= OCTET STRING (SIZE (7))

```

```

GSMLocation ::= CHOICE
{
  geoCoordinates [1] SEQUENCE
  {
    latitude [1] PrintableString (SIZE(7..10)),

```

```

        longitude      [2] PrintableString (SIZE(8..11)),
        mapDatum      [3] MapDatum DEFAULT WGS84,
        ...
        azimuth       [4] INTEGER (0..359) OPTIONAL
        -- The azimuth is the bearing, relative to true north.
    },
    -- format :      XDDMMSS.SS
    -- X            : N(orth), S(outh), E(ast), W(est)
    -- DD or DDD   : degrees (numeric characters)
    -- MM         : minutes (numeric characters)
    -- SS.SS      : seconds, the second part (.SS) is optionnal
    -- Example :
    -- latitude short form      N502312
    -- longitude long form     E1122312.18

    utmCoordinates [2] SEQUENCE
    {
        utm-East      [1] PrintableString (SIZE(10)),
        utm-North     [2] PrintableString (SIZE(7)),
        -- example   utm-East      32U0439955
        --           utm-North     5540736
        mapDatum      [3] MapDatum DEFAULT WGS84,
        ...
        azimuth       [4] INTEGER (0..359) OPTIONAL
        -- The azimuth is the bearing, relative to true north.
    },

    utmRefCoordinates [3] SEQUENCE
    {
        utmref-string PrintableString (SIZE(13)),
        mapDatum      MapDatum DEFAULT WGS84,
        ...
    },
    -- example 32UPU91294045

    wGS84Coordinates [4] OCTET STRING
    -- format is as defined in [37]; polygon type of shape is not allowed.
}

MapDatum ::= ENUMERATED
{
    wGS84,
    wGS72,
    eD50, -- European Datum 50
    ...
}

```

```

UMTSLocation ::= CHOICE {
    point          [1] GA-Point,
    pointWithUnCertainty [2] GA-PointWithUnCertainty,
    polygon        [3] GA-Polygon
}

```

```

GeographicalCoordinates ::= SEQUENCE {
    latitudeSign     ENUMERATED { north, south },
    latitude         INTEGER (0..8388607),
    longitude        INTEGER (-8388608..8388607),
    ...
}

```

```

GA-Point ::= SEQUENCE {
    geographicalCoordinates GeographicalCoordinates,
    ...
}

```

```

GA-PointWithUnCertainty ::= SEQUENCE {
    geographicalCoordinates GeographicalCoordinates,
    uncertaintyCode        INTEGER (0..127)
}

```

```

maxNrOfPoints INTEGER ::= 15

```

```

GA-Polygon ::= SEQUENCE (SIZE (1..maxNrOfPoints)) OF
SEQUENCE {

```

```

    geographicalCoordinates    GeographicalCoordinates,
    ...
}

```

```

SMS-report ::= SEQUENCE
{
    SMS-Contents    [3] SEQUENCE
    {
        sms-initiator    [1] ENUMERATED -- party which sent the SMS
        {
            target        (0),
            server        (1),
            undefined-party (2),
            ...
        },
        transfer-status    [2] ENUMERATED
        {
            succeed-transfer    (0), -- the transfer of the SMS message succeeds
            not-succeed-transfer (1),
            undefined            (2),
            ...
        } OPTIONAL,
        other-message    [3] ENUMERATED -- in case of terminating call, indicates if
        -- the server will send other SMS
        {
            yes            (0),
            no             (1),
            undefined      (2),
            ...
        } OPTIONAL,
        content            [4] OCTET STRING (SIZE (1 .. 270)) OPTIONAL,
        -- Encoded in the format defined for the SMS mobile
        ...
    }
}

```

```

GPRSCorrelationNumber ::= OCTET STRING (SIZE(8..20))

```

```

GPRSEvent ::= ENUMERATED
{
    pDPContextActivation            (1),
    startOfInterceptionWithPDPCContextActive (2),
    pDPContextDeactivation         (4),
    gPRSAttach                     (5),
    gPRSDetach                     (6),
    locationInfoUpdate             (10),
    SMS                             (11),
    pDPContextModification         (13),
    servingSystem                  (14),
    ...
}
-- see ref [10]

```

```

IMSevent ::= ENUMERATED
{
    sIPmessage (1),
    ...
}

```

```

Services-Data-Information ::= SEQUENCE
{
    gPRS-parameters [1] GPRS-parameters OPTIONAL,
    ...
}

```

```

GPRS-parameters ::= SEQUENCE
{
    pDP-address-allocated-to-the-target    [1] DataNodeAddress OPTIONAL,
    aPN                                    [2] OCTET STRING (SIZE(1..100)) OPTIONAL,
    pDP-type                               [3] OCTET STRING (SIZE(2)) OPTIONAL,
    ...
}

```

```

GPRSOperationErrorCode ::= OCTET STRING (SIZE(2))
-- refer to standard [9] for values(GMM cause or SM cause parameter).

```

```
UmtsQos ::= CHOICE
{
  qosMobileRadio [1] OCTET STRING,
    -- The qosMobileRadio parameter shall be coded in accordance with the § 10.5.6.5 of
    -- document [9] or [21] without the Quality of service IEI and Length of
    -- quality of service IE (. That is, first
    -- two octets carrying 'Quality of service IEI' and 'Length of quality of service
    -- IE' shall be excluded).
  qosGn [2] OCTET STRING
    -- qosGn parameter shall be coded in accordance with § 7.7.34 of document [17]
}
```

```
END -- OF UmtsHI2Operations
```

---



## CHANGE REQUEST

**33.108 CR 054** rev - Current version: **6.6.0**

For **HELP** on using this form, see bottom of this page or look at the pop-up text over the symbols.

Proposed change affects:  UICC apps  ME  Radio Access Network  Core Network

<b>Title:</b>	Correction of the Subaddressing definitions		
<b>Source:</b>	SA WG3 (LI Group)		
<b>Work item code:</b>	SEC1-LI	<b>Date:</b>	06/07/2004
<b>Category:</b>	<b>C</b>	<b>Release:</b>	Rel-6
	Use <u>one</u> of the following categories: <b>F</b> (correction) <b>A</b> (corresponds to a correction in an earlier release) <b>B</b> (addition of feature), <b>C</b> (functional modification of feature) <b>D</b> (editorial modification) Detailed explanations of the above categories can be found in 3GPP <a href="#">TR 21.900</a> .		Use <u>one</u> of the following releases: 2 (GSM Phase 2) R96 (Release 1996) R97 (Release 1997) R98 (Release 1998) R99 (Release 1999) Rel-4 (Release 4) Rel-5 (Release 5) Rel-6 (Release 6)

<b>Reason for change:</b>	Allow to send Mobile Teleservice Code or Mobile Bearer Service Code alone
<b>Summary of change:</b>	Allow to send Mobile Teleservice Code or Mobile Bearer Service Code alone
<b>Consequences if not approved:</b>	Missing information for the interception organisations. Update in TS 101 671 is already done

<b>Clauses affected:</b>	J.2.3.2				
<b>Other specs affected:</b>	<table border="1" style="display: inline-table; border-collapse: collapse;"> <tr> <td style="width: 20px; text-align: center;">Y</td> <td style="width: 20px; text-align: center;">N</td> </tr> <tr> <td style="text-align: center;"><input type="checkbox"/></td> <td style="text-align: center;"><input checked="" type="checkbox"/></td> </tr> </table> Other core specifications	Y	N	<input type="checkbox"/>	<input checked="" type="checkbox"/>
Y	N				
<input type="checkbox"/>	<input checked="" type="checkbox"/>				
	<table border="1" style="display: inline-table; border-collapse: collapse;"> <tr> <td style="width: 20px; text-align: center;"><input type="checkbox"/></td> <td style="width: 20px; text-align: center;"><input checked="" type="checkbox"/></td> </tr> </table> Test specifications	<input type="checkbox"/>	<input checked="" type="checkbox"/>		
<input type="checkbox"/>	<input checked="" type="checkbox"/>				
	<table border="1" style="display: inline-table; border-collapse: collapse;"> <tr> <td style="width: 20px; text-align: center;"><input type="checkbox"/></td> <td style="width: 20px; text-align: center;"><input checked="" type="checkbox"/></td> </tr> </table> O&M Specifications	<input type="checkbox"/>	<input checked="" type="checkbox"/>		
<input type="checkbox"/>	<input checked="" type="checkbox"/>				
<b>Other comments:</b>					

**\*\*\*\* Change \*\*\*\***

**J.2.3.2 Field order and layout**

Fields shall be presented into the subaddress in the following order:

**Table J.2.3: Fields in the Called Party Subaddress**

Order	Field
1	Operator-ID
2	CIN
3	CCLID
4	National Parameters

**Table J.2.4: Fields in the Calling Party Subaddress**

Order	Field
1	Lawful Interception Identifier (LIID)
2	Direction
3	Service Octets

Apart from National Parameters, inclusion and format of which is determined by national regulations, each field noted above shall be included, whether empty or not. Each of the Operator-ID, CIN, CCLID, LIID and Direction fields shall end by a field separator.

When sending entity does not have a valid value for either of Operator-ID, CIN, CCLID, LIID or Direction fields, then the field is considered empty and it shall be represented only by its field separator.

**Table J.2.4A: Example of how field separator should be used when field is empty**

Bits								Octets
8	7	6	5	4	3	2	1	
Called party subaddress identifier								1
Length of called party subaddress contents								2
Type of subaddress = user specified, odd/even indicator								3
Operator-ID ②				Operator-ID ①				4
Operator-ID ④				Operator-ID ③				5
Field separator				Operator-ID ⑤				6
CCLID ①				Field separator				7
CCLID ③				CCLID ②				8
CCLID ⑤				CCLID ④				9
CCLID ⑦				CCLID ⑥				10
Field separator				CCLID ⑧				11
								12
								13
								14
								15
(see note)								16
								17
								18
								19
								20
								21
								22
								23
NOTE: The Octets after the final field (CCLID) of the Called Party Subaddress are reserved for national use, e.g. for authentication purposes.								

The Service Octets as available shall always be mapped into octets 19 to 23 of the Calling Party Subaddress, as appropriate. If one of the parameters TMR, BC or HLC is not available, the octet shall be filled with "FF" hex.

In relation to Mobile Bearer Service Code and Mobile Teleservice Code, the mapping of the values into octets 22 and 23, respectively, shall be done as follows:

- i. if both, Mobile Bearer Service Code and Mobile Teleservice Code are provided by signalling, octets 22 and 23, shall be present, each containing the mapped value;
- ii. if Mobile Bearer Service Code is provided by signalling, and Mobile Teleservice Code is NOT provided by signalling, octet 22 shall be present containing the mapped value, and octet 23 shall be omitted;
- iii. if Mobile Teleservice Code is provided by signalling, and Mobile Bearer Service Code is NOT provided by signalling, there are two implementation options:
  - iii.1) neither octet 22 nor octet 23 shall be present;
  - iii.2) octet 22 shall be filled with "FF" hex and octet 23 shall be present containing the mapped value;
- iv. if neither Mobile Teleservice Code nor Mobile Bearer Service Code is provided by signalling, neither octet 22 nor octet 23 shall be present.

~~If Mobile Teleservice Code is not available, octet 23 shall not be transmitted. If Mobile Teleservice Code and Mobile Bearer Service Code are not available, octets 22 and 23 shall not be transmitted.~~

Table J.2.5 represent called party subaddress and table J.2.6 calling party subaddress with the maximum length of the identifiers.

**Table J.2.5: Called Party Subaddress**

Bits							Octets
8	7	6	5	4	3	2	
Called party subaddress identifier							1
Length of called party subaddress contents							2
Type of subaddress = user specified, odd/even indicator							3
Operator-ID ②				Operator-ID ①			4
Operator-ID ④				Operator-ID ③			5
Field separator				Operator-ID ⑤			6
CIN ②			CIN ①				7
CIN ④			CIN ③				8
CIN ⑥			CIN ⑤				9
CIN ⑧			CIN ⑦				10
CCLID ①			Field separator				11
CCLID ③			CCLID ②				12
CCLID ⑤			CCLID ④				13
CCLID ⑦			CCLID ⑥				14
Field separator			CCLID ⑧				15
see note							16
							17
							18
							19
							20
							21
							22
							23
NOTE: The Octets after the final field (CCLID) of the Called Party Subaddress are reserved for national use, e.g. for authentication purposes.							

Table J.2.6: Calling Party Subaddress

Bits							Octets
8	7	6	5	4	3	2	
Calling party subaddress identifier							1
Length of calling party subaddress contents							2
Type of subaddress = user specified, odd/even indicator according to the amount of BCD-digits							3
LIID ②			LIID ①			4	
LIID ④			LIID ③			5	
LIID ⑥			LIID ⑤			6	
LIID ⑧			LIID ⑦			7	
LIID ①⑩			LIID ⑨			8	
LIID ①②			LIID ①①			9	
LIID ①④			LIID ①③			10	
LIID ①⑥			LIID ①⑤			11	
LIID ①⑧			LIID ①⑦			12	
LIID ②⑩			LIID ②⑨			13	
LIID ②②			LIID ②①			14	
LIID ②④			LIID ②③			15	
Field separator			LIID ②⑤			16	
Field separator			Direction			17	
spare			spare			18	
ITU-T Recommendation Q.763 [32] TMR (see note 1)							19
ITU-T Recommendation Q.931 BC [33] octet 3 (see note 2)							20
ITU-T Recommendation Q.931 HLC [33] octet 4 (see note 3)							21
Mobile Bearer Service Code (see note 4)							22
Mobile Teleservice Code (see note 5)							23
NOTE 1: If available, the Transmission Medium Requirement according to EN 300 356 [29]. If not available, the value is "FF" hex.							
NOTE 2: If available, only octet 3 of the Bearer Capability I.E. according to EN 300 403 [30] If not available, the value is "FF" hex.							
NOTE 3: If available, only octet 4 of the High Layer Compatibility I.E. according to EN 300 403 [30]. If not available, the value is "FF" hex.							
NOTE 4: If available, the Mobile Bearer Service Code according to ETS 300 974 [34], clause 14.7.10. If not available, the octets 22 and 23 ( <a href="#">even if the mobile teleservice code is available</a> ) shall not be transmitted. <a href="#">If the mobile teleservice code is available optionally octet 22 could be filled with "FF" hex and be transmitted.</a>							
NOTE 5: If available, the Mobile Teleservice Code according to ETS 300 974 [34], clause 14.7.9. If not available, the octet 23 shall not be transmitted.							

## CHANGE REQUEST

**33.108 CR 055** rev - Current version: **6.6.0**

For **HELP** on using this form, see bottom of this page or look at the pop-up text over the symbols.

**Proposed change affects:** | UICC apps  ME  Radio Access Network  Core Network

<b>Title:</b>	Correction to hi3DomainId definition		
<b>Source:</b>	SA WG3 (LI Group)		
<b>Work item code:</b>	SEC-LI	<b>Date:</b>	12.07.2004
<b>Category:</b>	<b>F</b>	<b>Release:</b>	Rel-6
	Use <u>one</u> of the following categories: <b>F</b> (correction) <b>A</b> (corresponds to a correction in an earlier release) <b>B</b> (addition of feature), <b>C</b> (functional modification of feature) <b>D</b> (editorial modification) Detailed explanations of the above categories can be found in 3GPP <a href="#">TR 21.900</a> .		Use <u>one</u> of the following releases: 2 (GSM Phase 2) R96 (Release 1996) R97 (Release 1997) R98 (Release 1998) R99 (Release 1999) Rel-4 (Release 4) Rel-5 (Release 5) Rel-6 (Release 6)

<b>Reason for change:</b>	Lately we inserted r5 and r6 nodes into 3GPP module. However, this has not been added to the object identifier definition for hi3DomainId, which now is incorrect.  In some countries additional parameters are needed in CC header. It is proposed to define a 'National-HI3-ASN1parameters' data type for the HI3 module.  Besides, module versions need to be updated.
<b>Summary of change:</b>	CR offers to correct hi3DomainId definition, and to add optional parameter to CC header.
<b>Consequences if not approved:</b>	hi3DomainId object identifier points to a wrong object, which will lead to incorrect implementation.

<b>Clauses affected:</b>	B4										
<b>Other specs affected:</b>	<table border="1" style="display: inline-table; border-collapse: collapse;"> <tr> <td style="width: 20px;">Y</td> <td style="width: 20px;">N</td> </tr> <tr> <td style="text-align: center;">X</td> <td></td> </tr> <tr> <td style="text-align: center;">X</td> <td></td> </tr> <tr> <td style="text-align: center;">X</td> <td></td> </tr> </table> Other core specifications Test specifications O&M Specifications	Y	N	X		X		X			
Y	N										
X											
X											
X											
<b>Other comments:</b>											

## B.4 HI3 CC definition

```
Umts-HI3-PS {itu-t(0) identified-organization(4) etsi(0) securityDomain(2) lawfulintercept(2)
threeGPP(4) hi3(2) r6(6) version-2±(2±)}
```

```
DEFINITIONS IMPLICIT TAGS ::=
```

```
BEGIN
```

```
IMPORTS
```

```
GPRSCorrelationNumber
```

```
FROM UmtsHI2Operations
```

```
{itu-t(0) identified-organization(4) etsi(0) securityDomain(2) lawfulintercept(2) threeGPP(4)
hi2(1) r6(6) version-3(3)} -- from 3GPP UmtsHI2Operations
```

```
LawfulInterceptionIdentifier,
```

```
TimeStamp
```

```
FROM HI2Operations
```

```
{itu-t(0) identified-organization(4) etsi(0) securityDomain(2) lawfulIntercept(2) hi2(1)
version53(53)}; -- from ETSI HI2Operations TS 101 671v2.9.1-Edition-3
```

```
-- Object Identifier Definitions
```

```
-- Security DomainId
```

```
lawfulInterceptDomainId OBJECT IDENTIFIER ::= {itu-t(0) identified-organization(4) etsi(0)
securityDomain(2) lawfulIntercept(2)}
```

```
-- Security Subdomains
```

```
threeGPPSUBDomainId OBJECT IDENTIFIER ::= {lawfulInterceptDomainId threeGPP(4)}
```

```
hi3DomainId OBJECT IDENTIFIER ::= {threeGPPSUBDomainId hi3-(2) r6(6) version-2±(2±)}
```

```
CC-PDU ::= SEQUENCE
```

```
{
  uLIC-header      [1] ULIC-header,
  payload          [2] OCTET STRING
}
```

```
ULIC-header ::= SEQUENCE
```

```
{
  hi3DomainId      [0] OBJECT IDENTIFIER, -- 3GPP HI3 Domain
  version          [1] Version,
  lIID             [2] LawfulInterceptionIdentifier OPTIONAL,
  correlation-Number [3] GPRSCorrelationNumber,
  timeStamp        [4] TimeStamp OPTIONAL,
  sequence-number  [5] INTEGER (0..65535),
  t-PDU-direction [6] TPDU-direction,
  ...
  national-HI3-ASN1parameters [7] National-HI3-ASN1parameters OPTIONAL
  -- encoded per national requirements
}
```

```
Version ::= ENUMERATED
```

```
{
  version1(1),
  ...
}
```

```
TPDU-direction ::= ENUMERATED
```

```
{
  from-target      (1),
  to-target        (2),
  unknown          (3)
}
```

```
...
```

```
National-HI3-ASN1parameters ::= SEQUENCE
```

```
{  
  countryCode      [1] PrintableString (SIZE (2)),  
  -- Country Code according to ISO 3166-1 [xx],  
  -- the country to which the parameters inserted after the extension marker apply  
  ...  
  -- In case a given country wants to use additional national parameters according to its law,  
  -- these national parameters should be defined using the ASN.1 syntax and added after the  
  -- extension marker (...).  
  -- It is recommended that "version parameter" and "vendor identification parameter" are  
  -- included in the national parameters definition. Vendor identifications can be  
  -- retrieved from IANA web site.  
}
```

. . .

END-- OF Umts-HI3-PS

## CHANGE REQUEST

**33.108 CR 056** rev - Current version: **6.6.0**

For **HELP** on using this form, see bottom of this page or look at the pop-up text over the symbols.

**Proposed change affects:** | UICC apps  ME  Radio Access Network  Core Network

<b>Title:</b>	Correction of wrong use of abbreviations		
<b>Source:</b>	SA WG3 (LI Group)		
<b>Work item code:</b>	SEC-LI	<b>Date:</b>	20.07.2004
<b>Category:</b>	<b>D</b>	<b>Release:</b>	Rel-6
	Use <u>one</u> of the following categories: <b>F</b> (correction) <b>A</b> (corresponds to a correction in an earlier release) <b>B</b> (addition of feature), <b>C</b> (functional modification of feature) <b>D</b> (editorial modification) Detailed explanations of the above categories can be found in 3GPP <a href="#">TR 21.900</a> .		Use <u>one</u> of the following releases: 2 (GSM Phase 2) R96 (Release 1996) R97 (Release 1997) R98 (Release 1998) R99 (Release 1999) Rel-4 (Release 4) Rel-5 (Release 5) Rel-6 (Release 6)

<b>Reason for change:</b>	Correction of wrong use of CD abbreviation Correction of wrong use of IP abbreviation		
<b>Summary of change:</b>	CR offers to correct wrong use of abbreviations		
<b>Consequences if not approved:</b>	Incorrect specification		

<b>Clauses affected:</b>	5.6										
<b>Other specs affected:</b>	<table border="1" style="display: inline-table; border-collapse: collapse;"> <tr> <td style="text-align: center;">Y</td> <td style="text-align: center;">N</td> </tr> <tr> <td style="text-align: center;"><input type="checkbox"/></td> <td style="text-align: center;"><input checked="" type="checkbox"/></td> </tr> <tr> <td style="text-align: center;"><input type="checkbox"/></td> <td style="text-align: center;"><input checked="" type="checkbox"/></td> </tr> <tr> <td style="text-align: center;"><input type="checkbox"/></td> <td style="text-align: center;"><input checked="" type="checkbox"/></td> </tr> </table>	Y	N	<input type="checkbox"/>	<input checked="" type="checkbox"/>	<input type="checkbox"/>	<input checked="" type="checkbox"/>	<input type="checkbox"/>	<input checked="" type="checkbox"/>	Other core specifications Test specifications O&M Specifications	
Y	N										
<input type="checkbox"/>	<input checked="" type="checkbox"/>										
<input type="checkbox"/>	<input checked="" type="checkbox"/>										
<input type="checkbox"/>	<input checked="" type="checkbox"/>										
<b>Other comments:</b>											



## 5.6 Functional architecture

The following picture contains the reference configuration for the lawful interception (see [19]).

There is one Administration Function (ADMF) in the network. Together with the delivery functions it is used to hide from the 3G MSC server and 3G GMSC server that there might be multiple activations by different Law Enforcement Agencies (LEAs) on the same target.

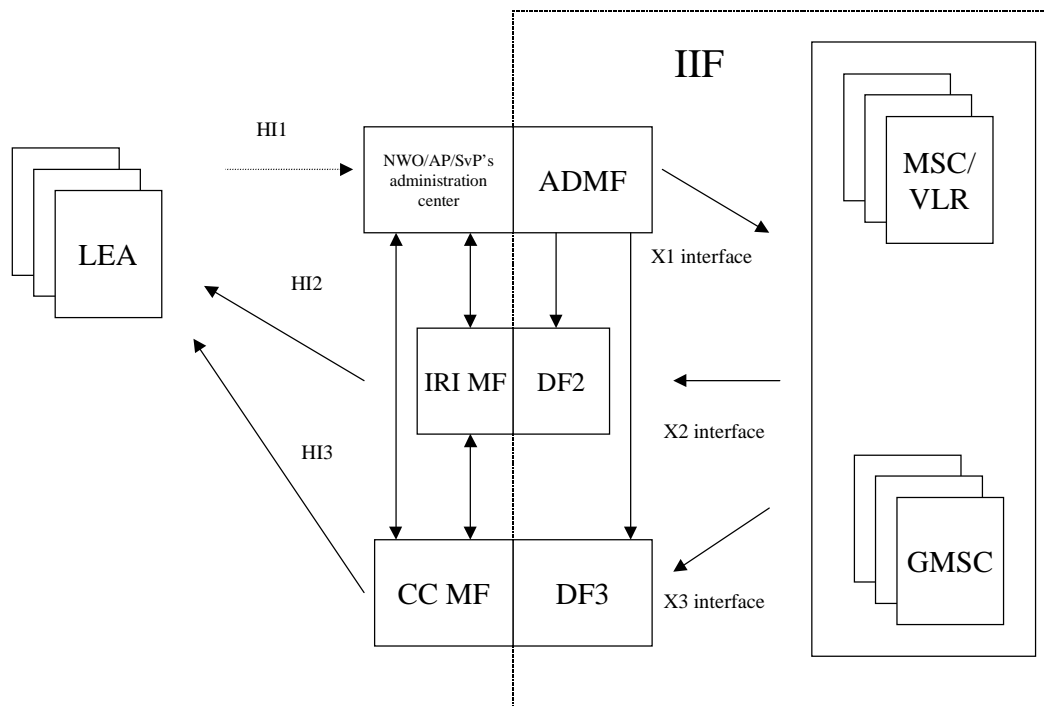

**Figure 5.4: Reference configuration for Circuit switched**

The reference configuration is only a logical representation of the entities involved in lawful interception and does not mandate separate physical entities. This allows for higher levels of integration.

A call could be intercepted based on several identities (MSISDN, IMSI, IMEI) of the same target.

Interception based on IMEI could lead to a delay in start of interception at the beginning of a call and interception of non-call related events is not possible.

For the delivery of the ~~IP(CC)~~ and ~~IRI(CC)~~ the 3G MSC server or 3G GMSC server provides correlation number and target identity to the DF2 and DF3 which is used there in order to select the different LEAs where the product shall be delivered to.

## CHANGE REQUEST

**33.108 CR 057** rev - Current version: **6.6.0**

For **HELP** on using this form, see bottom of this page or look at the pop-up text over the symbols.

Proposed change affects: UICC apps  ME  Radio Access Network  Core Network

<b>Title:</b>	Differences between subaddress sections in 33.108 and ETSI TS 101 671		
<b>Source:</b>	SA WG3 (LI Group)		
<b>Work item code:</b>	SEC1-LI	<b>Date:</b>	20.07.2004
<b>Category:</b>	<b>C</b>	<b>Release:</b>	Rel-6
	Use <u>one</u> of the following categories: <b>F</b> (correction) <b>A</b> (corresponds to a correction in an earlier release) <b>B</b> (addition of feature), <b>C</b> (functional modification of feature) <b>D</b> (editorial modification) Detailed explanations of the above categories can be found in 3GPP <a href="#">TR 21.900</a> .		Use <u>one</u> of the following releases: 2 (GSM Phase 2) R96 (Release 1996) R97 (Release 1997) R98 (Release 1998) R99 (Release 1999) Rel-4 (Release 4) Rel-5 (Release 5) Rel-6 (Release 6)

<b>Reason for change:</b>	This CR illustrates differences between subaddress coding clauses in 33.108 and ETSI TS 101 671.  "S3LI04_115 correction of the subaddressing" definitions covers part of these differences. However, in some countries more flexible, variable length parameters are required.  Besides, in subclauses J.2.2 and J.3.3 reference [30] points to wrong specification. The right reference number should be [31].
<b>Summary of change:</b>	Variable length parameters are introduced and reference numbers were corrected.
<b>Consequences if not approved:</b>	Potential confusion over subaddressing definitions in 33.107 and 33.108.

<b>Clauses affected:</b>	J.2.2 and J.3.3						
<b>Other specs affected:</b>	<table border="1" style="display: inline-table; border-collapse: collapse;"> <tr> <td style="width: 20px; text-align: center;">Y</td> <td style="width: 20px; text-align: center;">N</td> </tr> <tr> <td style="text-align: center;"><input type="checkbox"/></td> <td style="text-align: center;"><input checked="" type="checkbox"/></td> </tr> </table> Other core specifications	Y	N	<input type="checkbox"/>	<input checked="" type="checkbox"/>		
Y	N						
<input type="checkbox"/>	<input checked="" type="checkbox"/>						
	<table border="1" style="display: inline-table; border-collapse: collapse;"> <tr> <td style="width: 20px; text-align: center;"><input checked="" type="checkbox"/></td> <td style="width: 20px; text-align: center;"><input checked="" type="checkbox"/></td> </tr> <tr> <td style="text-align: center;">Test specifications</td> <td style="text-align: center;">O&amp;M Specifications</td> </tr> </table>	<input checked="" type="checkbox"/>	<input checked="" type="checkbox"/>	Test specifications	O&M Specifications		
<input checked="" type="checkbox"/>	<input checked="" type="checkbox"/>						
Test specifications	O&M Specifications						
<b>Other comments:</b>							

## J.2.2 Subaddress options

The coding of a subaddress information element is given in [310]. The following options shall be chosen:

**Table J.2.1: Subaddress options**

Option	Value
Type of subaddress	user specified
Odd/even indicator	employed for called party subaddress when no national parameters are used

## J.2.3 Subaddress coding

The coding of subaddress information shall be in accordance with [310].

### J.2.3.1 BCD Values

The values 0-9 shall be BCD coded according to their natural binary values. The hexadecimal value F shall be used as a field separator. This coding is indicated in table J.2.2.

**Table J.2.2: Coding BCD values**

Item	BCD representation			
	Bit 4	Bit 3	Bit 2	Bit 1
0	0	0	0	0
1	0	0	0	1
2	0	0	1	0
3	0	0	1	1
4	0	1	0	0
5	0	1	0	1
6	0	1	1	0
7	0	1	1	1
8	1	0	0	0
9	1	0	0	1
Field separator	1	1	1	1

When items are packed two to an octet, the least significant item shall be coded by mapping bit 4 to bit 8, bit 3 to bit 7, etc.

### J.2.3.2 Field order and layout

Fields shall be presented into the subaddress in the following order:

**Table J.2.3: Fields in the Called Party Subaddress**

Order	Field
1	Operator-ID
2	CIN
3	CCLID
4	National Parameters

**Table J.2.4: Fields in the Calling Party Subaddress**

Order	Field
1	Lawful Interception Identifier (LIID)
2	Direction
3	Service Octets

Apart from National Parameters, inclusion and format of which is determined by national regulations, each field noted above shall be included, whether empty or not. Each of the Operator-ID, CIN, CCLID, LIID and Direction fields shall end by a field separator.

When sending entity does not have a valid value for either of Operator-ID, CIN, CCLID, LIID or Direction fields, then the field is considered empty and it shall be represented only by its field separator.

**Table J.2.4A: Example of how field separator should be used when field is empty**

Bits								Octets
8	7	6	5	4	3	2	1	
Called party subaddress identifier								1
Length of called party subaddress contents								2
Type of subaddress = user specified, odd/even indicator								3
Operator-ID ②				Operator-ID ①				4
Operator-ID ④				Operator-ID ③				5
Field separator				Operator-ID ⑤				6
CCLID ①				Field separator				7
CCLID ③				CCLID ②				8
CCLID ⑤				CCLID ④				9
CCLID ⑦				CCLID ⑥				10
Field separator				CCLID ⑧				11
								12
								13
								14
								15
(see note)								16
								17
								18
								19
								20
								21
								22
								23
NOTE: The Octets after the final field (CCLID) of the Called Party Subaddress are reserved for national use, e.g. for authentication purposes.								

The parameters within the Information Elements "Called Party Subaddress" and "Calling Party Subaddress" are variable. Because of this variable length the parameters may start in different octets in the related Information Element. I.e. in the Calling Party Subaddress the Direction can be found in octet 17 when the LIID is 25 digits long (table E.3.5).

When the LIID is composed of less than 25 digits, the field separator and direction indicator "moves up" and the rest of the octets is spare till octet 19 as shown in table E.3.7. Between the last digit of the LIID and the Direction is always a Field separator (value F). Also after the "Direction" one Field Separator is given. The last Field separator separates the relevant data from the spare part. So the location of the TMR and the other service Octets below are fixed within the Subaddress. The total length of the Calling Party Subaddress is fixed to 23 octets (including the two Mobile service octets) or 21 octets (without the two Mobile service octets).

The Service Octets as available shall always be mapped into octets 19 to 23 of the Calling Party Subaddress, as appropriate. If one of the parameters TMR, BC or HLC is not available, the octet shall be filled with "FF" hex. If Mobile Teleservice Code is not available, octet 23 shall not be transmitted. If Mobile Teleservice Code and Mobile Bearer Service Code are not available, octets 22 and 23 shall not be transmitted.

As an option the Calling Party Subaddress and Called Party Subaddress may have a variable length. The length is given in octet 2.

When the LIID is composed of less than 25 digits in the Calling Party Subaddress, the Field separator, Direction indicator, Field separator and all the Service Octets "moves up" as shown in table E.3.8.

National Parameters in a variable length Called Party Subaddress may have variable length.

Table J.2.5 represent called party subaddress and table J.2.6 calling party subaddress with the maximum length of the identifiers.

**Table J.2.5: Called Party Subaddress**

Bits							Octets
8	7	6	5	4	3	2	
Called party subaddress identifier							1
Length of called party subaddress contents							2
Type of subaddress = user specified, odd/even indicator							3
Operator-ID ②			Operator-ID ①				4
Operator-ID ④			Operator-ID ③				5
Field separator			Operator-ID ⑤				6
CIN ②			CIN ①				7
CIN ④			CIN ③				8
CIN ⑥			CIN ⑤				9
CIN ⑧			CIN ⑦				10
CCLID ①			Field separator				11
CCLID ③			CCLID ②				12
CCLID ⑤			CCLID ④				13
CCLID ⑦			CCLID ⑥				14
Field separator			CCLID ⑧				15
see note							16
							17
							18
							19
							20
							21
							22
							23
NOTE: The Octets after the final field (CCLID) of the Called Party Subaddress are reserved for national use, e.g. for authentication purposes.							

**Table J.2.6: Calling Party Subaddress**

Bits							Octets
8	7	6	5	4	3	2	
Calling party subaddress identifier							1
Length of calling party subaddress contents							2
Type of subaddress = user specified, odd/even indicator according to the amount of BCD-digits							3
LIID ②			LIID ①			4	
LIID ④			LIID ③			5	
LIID ⑥			LIID ⑤			6	
LIID ⑧			LIID ⑦			7	
LIID ①⑩			LIID ⑨			8	
LIID ①②			LIID ①①			9	
LIID ①④			LIID ①③			10	
LIID ①⑥			LIID ①⑤			11	
LIID ①⑧			LIID ①⑦			12	
LIID ②⑩			LIID ②⑨			13	
LIID ②②			LIID ②①			14	
LIID ②④			LIID ②③			15	
Field separator			LIID ②⑤			16	
Field separator			Direction			17	
spare			spare			18	
ITU-T Recommendation Q.763 [32] TMR (see note 1)							19
ITU-T Recommendation Q.931 BC [33] octet 3 (see note 2)							20
ITU-T Recommendation Q.931 HLC [33] octet 4 (see note 3)							21
Mobile Bearer Service Code (see note 4)							22
Mobile Teleservice Code (see note 5)							23
NOTE 1: If available, the Transmission Medium Requirement according to EN 300 356 [29]. If not available, the value is "FF" hex.							
NOTE 2: If available, only octet 3 of the Bearer Capability I.E. according to EN 300 403 [31] If not available, the value is "FF" hex.							
NOTE 3: If available, only octet 4 of the High Layer Compatibility I.E. according to EN 300 403 [31]. If not available, the value is "FF" hex.							
NOTE 4: If available, the Mobile Bearer Service Code according to ETS 300 974 [34], clause 14.7.10. If not available, the octets 22 and 23 shall not be transmitted.							
NOTE 5: If available, the Mobile Teleservice Code according to ETS 300 974 [34], clause 14.7.9. If not available, the octet 23 shall not be transmitted.							

## CHANGE REQUEST

**33.108 CR 058** rev - Current version: **6.6.0**

For **HELP** on using this form, see bottom of this page or look at the pop-up text over the symbols.

**Proposed change affects:** UICC apps  ME  Radio Access Network  Core Network

<b>Title:</b>	Replace SIP URL with SIP URI		
<b>Source:</b>	SA WG3 (LI Group)		
<b>Work item code:</b>	SEC1-LI	<b>Date:</b>	12-07-2004
<b>Category:</b>	<b>F</b>	<b>Release:</b>	Rel-6
	Use <u>one</u> of the following categories: <b>F</b> (correction) <b>A</b> (corresponds to a correction in an earlier release) <b>B</b> (addition of feature), <b>C</b> (functional modification of feature) <b>D</b> (editorial modification) Detailed explanations of the above categories can be found in 3GPP <a href="#">TR 21.900</a> .		Use <u>one</u> of the following releases: 2 (GSM Phase 2) R96 (Release 1996) R97 (Release 1997) R98 (Release 1998) R99 (Release 1999) Rel-4 (Release 4) Rel-5 (Release 5) Rel-6 (Release 6)

<b>Reason for change:</b>	To be consistent with RFC 3261 and TS24.229 SIP usage
<b>Summary of change:</b>	The SIP URL is no longer used in RFC 3261 and TS 24.229. It has been changed to SIP URI to better reflect the usage.
<b>Consequences if not approved:</b>	There will be inconsistency with RFC3261 and TS24.229 and cause confusion.

<b>Clauses affected:</b>	3.2, 7.2, 7.2.1, B.3										
<b>Other specs affected:</b>	<table border="1" style="display: inline-table; border-collapse: collapse;"> <tr> <td style="width: 20px; text-align: center;">Y</td> <td style="width: 20px; text-align: center;">N</td> </tr> <tr> <td style="text-align: center;">X</td> <td style="text-align: center;"></td> </tr> <tr> <td style="text-align: center;"></td> <td style="text-align: center;">X</td> </tr> <tr> <td style="text-align: center;"></td> <td style="text-align: center;">X</td> </tr> </table> Other core specifications Test specifications O&M Specifications	Y	N	X			X		X		33.107
Y	N										
X											
	X										
	X										
<b>Other comments:</b>											

\*\*\*\* Change 1 \*\*\*\*

## 3.2 Abbreviations

For the purposes of the present document, the abbreviations given in 3GPP TR 21.905 [38] and the following apply:

AN	Access Network
ASN.1	Abstract Syntax Notation, Version 1
ASE	Application Service Element
BER	Basic Encoding Rules
CC	Content of Communication
CSCF	Call Session Control Function
DF	Delivery Function
FTP	File Transfer Protocol
GGSN	Gateway GPRS Support Node
GLIC	GPRS LI Correlation
GPRS	General Packet Radio Service
GSM	Global System for Mobile communications
GSN	GPRS Support Node (SGSN or GGSN)
GTP	GPRS Tunnelling Protocol
HI	Handover Interface
HI1	Handover Interface Port 1 (for Administrative Information)
HI2	Handover Interface Port 2 (for Intercept Related Information)
HI3	Handover Interface Port 3 (for Content of Communication)
HLC	High Layer Compatibility
IA	Interception Area
IA5	International Alphabet No. 5
IAP	Interception Access Point
ICI	Interception Configuration Information
IE	Information Element
IIF	Internal Interception Function
IMEI	International Mobile station Equipment Identity
IMS	IP Multimedia Core Network Subsystem
IMSI	International Mobile Subscriber Identity
INI	Internal network interface
IP	Internet Protocol
IPS	Internet Protocol Stack
IRI	Intercept Related Information
LEA	Law Enforcement Agency
LEMF	Law Enforcement Monitoring Facility
LI	Lawful Interception
LIID	Lawful Interception Identifier
LLC	Lower layer compatibility
LSB	Least significant bit
MAP	Mobile Application Part
MF	Mediation Function
MS	Mobile Station
MSB	Most significant bit
MSISDN	Mobile Subscriber ISDN Number
MSN	Multiple Subscriber Number
NEID	Network Element Identifier
NID	Network Identifier
NO	Network Operator
OA&M	Operation, Administration & Maintenance
P-CSCF	Proxy Call Session Control Function
PDP	Packet Data Protocol
PLMN	Public land mobile network
PSTN	Public Switched Telephone Network
ROSE	Remote Operation Service Element
R <sub>x</sub>	Receive direction



S-CSCF	Serving Call Session Control Function
SGSN	Serving GPRS Support Node
<a href="#">SIP</a>	<a href="#">Session Initiation Protocol</a>
SMAF	Service Management Agent Function
SMF	Service Management Function
SMS	Short Message Service
SP	Service Provider
TCP	Transmission Control Protocol
TI	Target identity
TP	Terminal Portability
T-PDU	tunneled PDU
T <sub>x</sub>	Transmit direction
UI	User Interaction
UMTS	Universal Mobile Telecommunication System
<a href="#">URI</a>	<a href="#">Universal Resource Identifier</a>
<a href="#">URL</a>	<a href="#">Universal Resource Locator</a>
VPN	Virtual Private Network

\*\*\*\* Change 2 \*\*\*\*

## 7.2 IRI for IMS

In addition, information on non-transmission related actions of a target constitute IRI and is sent via HI2, e.g. information on subscriber controlled input.

The IRI may be subdivided into the following categories:

1. Control information for HI2 (e.g. correlation information).
2. Basic data context information, for standard data transmission between two parties (e.g. SIP-message).

For each event, a Record is sent to the LEMF, if this is required. The following table gives the mapping between event type received at DF2 level and record type sent to the LEMF.

**Table 7.1: Mapping between IMS Events and HI2 Records Type**

Event	IRI Record Type
SIP-Message	REPORT

A set of information is used to generate the record. The records used transmit the information from mediation function to LEMF. This set of information can be extended in the CSCF or DF2 MF, if this is necessary in a specific country. The following table gives the mapping between information received per event and information sent in records.

**Table 7.2: Mapping between IMS Events Information and IRI Information**

Parameter	Description	HI2 ASN.1 parameter
Observed SIP UR L	Observed SIP UR L	partyInformation (sip-uri l)
Observed TEL URL	Observed TEL URL	partyInformation (tel-url)
Event type	IMS Event	iMSevent
Event date	Date of the event generation in the CSCF	timeStamp
Event time	Time of the event generation in the CSCF	
Network identifier	Unique number of the intercepting CSCF	networkIdentifier
Correlation number	Unique number for each PDP context delivered to the LEMF, to help the LEA, to have a correlation between each PDP Context and the IRI.	gPRSCorrelationNumber
Lawful interception identifier	Unique number for each lawful authorization.	lawfulInterceptionIdentifier
SIP message	Whole SIP message	sIPMessage

NOTE: LIID parameter must be present in each record sent to the LEMF.

\*\*\*\* Change 3 \*\*\*\*

### 7.2.1 Events and information

This clause describes the information sent from the Delivery Function (DF) to the Law Enforcement Monitoring Facility (LEMF) to support Lawfully Authorized Electronic Surveillance (LAES). The information is described as records and information carried by a record. This focus is on describing the information being transferred to the LEMF.

The IRI events and data are encoded into records as defined in the Table 7-1 Mapping between IMS Events and HI2 Records Type and Annex B.3 Intercept related information (HI2) [1]. IRI is described in terms of a 'causing event' and information associated with that event. Within each IRI Record there is a set of events and associated information elements to support the particular service.

The communication events described in Table 7-1: Mapping between the IMS Event and HI2 Record Type and Table 7-2: Mapping between IMS Events Information and IRI Information convey the basic information for reporting the disposition of a communication. This clause describes those events and supporting information.

Each record described in this clause consists of a set of parameters. Each parameter is either:

- mandatory (M) - required for the record,
- conditional (C) - required in situations where a condition is met (the condition is given in the Description), or
- optional (O) - provided at the discretion of the implementation.

The information to be carried by each parameter is identified. Both optional and conditional parameters are considered to be OPTIONAL syntactically in ASN.1 Stage 3 descriptions. The Stage 2 inclusion takes precedence over Stage 3 syntax.

**Table 7.3: SIP-Message REPORT Record**

Parameter	MOC	Description/Conditions
observed SIP-URI	C	SIP URI of the interception target (if available)
observed TEL-URL	C	TEL URL of the interception target (if available)
event type	M	Provide IMS event type.
event date	M	Provide the date and time the event is detected.
event time		
network identifier	M	Shall be provided.
lawful intercept identifier	M	Shall be provided.
correlation number	C	If available and not included in the SIP-message
SIP message	M	The relevant SIP message

\*\*\*\* Change 4 \*\*\*\*

## B.3 Intercept related information (HI2)

```

PartyInformation ::= SEQUENCE
{
  party-Qualifier [0] ENUMERATED
  {
    gPRS-Target(3),
    ...
  },
  partyIdentity [1] SEQUENCE
  {
    imei [1] OCTET STRING (SIZE (8)) OPTIONAL,
    -- See MAP format [4]

    imsi [3] OCTET STRING (SIZE (3..8)) OPTIONAL,
    -- See MAP format [4] International Mobile
    -- Station Identity E.212 number beginning with Mobile Country Code

    msISDN [6] OCTET STRING (SIZE (1..9)) OPTIONAL,
    -- MSISDN of the target, encoded in the same format as the AddressString
    -- parameters defined in MAP format document [4], § 14.7.8

    e164-Format [7] OCTET STRING (SIZE (1 .. 25)) OPTIONAL,
    -- E164 address of the node in international format. Coded in the same format as
    -- the calling party number parameter of the ISUP (parameter part:[5])

    sip-uri [8] OCTET STRING OPTIONAL,
    -- See [26]

    ...,
    tel-url [9] OCTET STRING OPTIONAL,
    -- See [36]
  },
  services-Data-Information [4] Services-Data-Information OPTIONAL,
  -- This parameter is used to transmit all the information concerning the
  -- complementary information associated to the basic data call
  ...
}

```

3GPP TSG-SA3 LI Meeting #15  
 Povia de Varzim, Portugal, 19-20 July 2004

Tdoc **S3LI04\_143r5**

CR-Form-v7
<b>CHANGE REQUEST</b>
⌘ <b>33.108 CR 059</b> ⌘ rev - ⌘ Current version: <b>6.6.0</b> ⌘

For **HELP** on using this form, see bottom of this page or look at the pop-up text over the ⌘ symbols.

**Proposed change affects:** | UICC apps  ME  Radio Access Network  Core Network

<b>Title:</b>	⌘ Corrections to References	
<b>Source:</b>	⌘ SA WG3 (LI Group)	
<b>Work item code:</b>	⌘ SEC1-LI	<b>Date:</b> ⌘ 29/07/2004
<b>Category:</b>	⌘ <b>F</b>	<b>Release:</b> ⌘ Rel-6
	Use <u>one</u> of the following categories: <b>F</b> (correction) <b>A</b> (corresponds to a correction in an earlier release) <b>B</b> (addition of feature), <b>C</b> (functional modification of feature) <b>D</b> (editorial modification) Detailed explanations of the above categories can be found in 3GPP <a href="#">TR 21.900</a> .	Use <u>one</u> of the following releases: 2 (GSM Phase 2) R96 (Release 1996) R97 (Release 1997) R98 (Release 1998) R99 (Release 1999) Rel-4 (Release 4) Rel-5 (Release 5) Rel-6 (Release 6)

<b>Reason for change:</b>	⌘ Correct the references.
<b>Summary of change:</b>	⌘ Correct the references and replace GSM references with 3GPP references as appropriate.  The date from [13] was removed. [21] was removed because it is the same as [9]. [22] was moved to Bibliography because it is not referenced in the spec. Version number from [24] was removed [32] was removed because it is not referenced in the spec and it was already in Bibliography.[35] was removed because it is the same as [4]. Note 1, 2 and 3 has been added to the References. References in table J.2.6 were corrected. 2., 3. and 17. were removed from Bibliography because they are used in the references.
<b>Consequences if not approved:</b>	⌘ Misalignment with 3GPP specifications.

<b>Clauses affected:</b>	⌘ 2 References, 5, 6.2.3, 6.5, 6.5.1, 7.2.1, A.1.2.1, B.3, C.1.2, Annex E								
<b>Other specs affected:</b>	<table border="1" style="display: inline-table; border-collapse: collapse;"> <tr> <td style="padding: 2px;">Y</td> <td style="padding: 2px;">N</td> </tr> <tr> <td style="padding: 2px;"><input type="checkbox"/></td> <td style="padding: 2px;"><input checked="" type="checkbox"/></td> </tr> <tr> <td style="padding: 2px;"><input type="checkbox"/></td> <td style="padding: 2px;"><input checked="" type="checkbox"/></td> </tr> <tr> <td style="padding: 2px;"><input type="checkbox"/></td> <td style="padding: 2px;"><input checked="" type="checkbox"/></td> </tr> </table> Other core specifications ⌘ Test specifications ⌘ O&M Specifications ⌘	Y	N	<input type="checkbox"/>	<input checked="" type="checkbox"/>	<input type="checkbox"/>	<input checked="" type="checkbox"/>	<input type="checkbox"/>	<input checked="" type="checkbox"/>
Y	N								
<input type="checkbox"/>	<input checked="" type="checkbox"/>								
<input type="checkbox"/>	<input checked="" type="checkbox"/>								
<input type="checkbox"/>	<input checked="" type="checkbox"/>								
<b>Other comments:</b>	⌘								

**\*\*\* First Change \*\*\***

## 2 References

The following documents contain provisions which, through reference in this text, constitute provisions of the present document.

- References are either specific (identified by date of publication, edition number, version number, etc.) or non-specific.
- For a specific reference, subsequent revisions do not apply.
- For a non-specific reference, the latest version applies. In the case of a reference to a 3GPP document (including a GSM document), a non-specific reference implicitly refers to the latest version of that document *in the same Release as the present document*.

- [1] ETSI TR 101 331: "Telecommunications security; Lawful Interception (LI); requirements of Law Enforcement Agencies".
- [2] ETSI ES 201 158: "Telecommunications security; Lawful Interception (LI); Requirements for network functions".
- [3] ETSI ETR 330: "Security Techniques Advisory Group (STAG); A guide to legislative and regulatory environment".
- [4] [3GPP TS 29.002 "3rd Generation Partnership Project; Technical Specification Group Core Network; Mobile Application Part \(MAP\) specification"](#); ~~GSM 09.02: "Digital cellular telecommunications system (Phase 2+); Mobile Application Part (MAP) specification"~~.
- [5] ITU-T Recommendations X.680-~~X.683~~: ~~"Specification of Abstract Syntax Notation One (ASN.1)"~~.  
[ITU-T Rec. X.680: "Abstract Syntax Notation One \(ASN.1\): Specification of Basic Notation"](#).  
[ITU-T Rec. X.681: "Abstract Syntax Notation One \(ASN.1\): Information Object Specification"](#).  
[ITU-T Rec. X.682: "Abstract Syntax Notation One \(ASN.1\): Constraint Specification"](#).  
[ITU-T Rec. X.683: "Abstract Syntax Notation One \(ASN.1\): Parameterization of ASN.1 Specifications"](#).
- [6] ITU-T Recommendation X.690: "[ASN.1 encoding rules: Specification of Basic Encoding Rules \(BER\), Canonical Encoding Rules \(CER\) and Distinguished Encoding Rules \(DER\)](#)~~Specification of basic encoding rules for Abstract Syntax Notation One (ASN.1)~~".
- [7] ITU-T Recommendation X.880: "Information technology - Remote Operations: Concepts, model and notation".
- [8] ITU-T Recommendation X.882: "Information technology - Remote Operations: OSI realizations - Remote Operations Service Element (ROSE) protocol specification".
- [9] [3GPP TS 24.008 "3GPP Technical Specification Group Core Network; Mobile radio interface Layer 3 specification, Core network protocol; Stage 3"](#); ~~ETSI EN 300 940, GSM 04.08: "Digital cellular communications system (Phase 2+); Mobile radio interface layer 3 specification"~~.
- ~~[10] ETSI TS 101 509: "Digital cellular telecommunications system (Phase 2+); Lawful interception; Stage 2 (GSM 03.33)~~.
- ~~[11] GSM 03.03: "Digital cellular telecommunications system (Phase 2+); Numbering, addressing and identification"~~.
- ~~[12] GSM 09.60 (ETSI EN 301 347): "Digital cellular telecommunications system (Phase 2+); General Packet Radio Service (GPRS); GPRS tunnelling protocol (GTP) across Gn and Gp Interface"~~.

- [13] [IETF STD 9 \(RFC 0959\)](#): "File Transfer Protocol (FTP)", ~~October 1985~~.
- [14] [3GPP TS 32.215](#)~~GSM 12.15~~: "3rd Generation Partnership Project; Technical Specification Group Services and System Aspects; Telecommunication Management; Charging [Management](#); [Charging data description](#)~~& Billing; GSM call and event data~~ for the Packet Switched (PS) domain)".
- [15] [IETF STD0005 \(RFC 0791\)](#): "Internet Protocol".
- [16] [IETF STD0007 \(RFC 0793\)](#): "Transmission Control Protocol".
- [17] 3GPP TS 29.060: "[3rd Generation Partnership Project; Technical Specification Group Core Network; General Packet Radio Service \(GPRS\); GPRS Tunnelling Protocol \(GTP\) across the Gn and Gp interface](#)".
- [18] 3GPP TS 33.106: "[3rd Generation Partnership Project; Technical Specification Group Services and System Aspects; 3G Security; Lawful Interception Requirements](#)".
- [19] 3GPP TS 33.107: "[3rd Generation Partnership Project; Technical Specification Group Services and System Aspects; 3G Security; Lawful ~~I~~nterception ~~A~~rchitecture and ~~F~~unctions](#)".
- [20] 3GPP TS 23.107: "[3rd Generation Partnership Project; Technical Specification Group Services and System Aspects; Quality of Service QoS ~~c~~oncepts and ~~a~~rchitecture](#)".
- ~~[21] 3GPP TS 24.008: "3GPP Technical Specification Group Core Network; Mobile radio interface layer 3 specification".~~
- ~~[22] ETSI ES 201 671 version 2.1.1: "Handover Interface for the lawful interception of telecommunications traffic".~~
- [23] [ANSI/J-STD-025-A](#): "Lawfully Authorized Electronic Surveillance".
- [24] ETSI TS 101 671 ~~version 2.3.1~~: "Handover Interface for the lawful interception of telecommunications traffic".
- [25] 3GPP TS 23.003: "3rd Generation Partnership Project; Technical Specification Group Core Network; Numbering, addressing, and identification".
- [26] [IETF RFC 3261](#): "SIP: Session Initiation Protocol".
- [27] [IETF RFC 1006](#): "ISO Transport Service on top of the TCP".
- [28] [IETF RFC 2126](#): "ISO Transport Service on top of TCP (ITOT)".
- [29] ITU-T Recommendation Q.763: "[Signalling System No. 7 - ISDN User Part formats and codes](#)~~Formats and Codes of the ISDN User Part of Signalling System No. 7~~".
- [30] ETSI EN 300 356 (all parts): "Integrated Services Digital Network (ISDN); Signalling System No.7; ISDN User Part (ISUP) version 3 for the international interface".
- [31] ETSI EN 300 403-1 (V1.32.2): "Integrated Services Digital Network (ISDN); Digital Subscriber Signalling System No. one (DSS1) protocol; Signalling network layer for circuit-mode basic call control; Part 1: Protocol specification [ITU-T Recommendation Q.931 (1993), modified]".
- ~~[32] ETSI EN 300 286 1: "Integrated Services Digital Network (ISDN); User to User Signalling (UUS) supplementary service; Digital Subscriber Signalling System No. one (DSS1) protocol; Part 1: Protocol specification".~~
- [33] ITU-T Recommendation Q.763: "Signalling System No.7 - ISDN User Part formats and codes".
- [34] ITU-T Recommendation Q.931: "ISDN user-network interface layer 3 specification for basic call control".
- ~~[35] 3GPP TS 29.002: "3rd Generation Partnership Project; Technical Specification Group Core Network; Mobile Application Part (MAP) specification".~~
- [36] [IETF RFC 2806](#): "URLs for Telephone Calls".

- [37] 3GPP TS 23.032: "3rd Generation Partnership Project; Technical Specification Group Core Network; Universal Geographical Area Description (GAD)".
- [38] 3GPP TR 21.905: "3rd Generation Partnership Project; Technical Specification Group Services and System Aspects; Vocabulary for 3GPP Specifications".

Note 1: [It is recommended that for \[5\] and \[6\] the 2002 specific versions should be used.](#)

Note 2: [It is recommended that for \[8\] the 1994 specific versions should be used.](#)

Note 3: [Reference \[31\] is specific, because ASN.1 parameter "release-Reason-Of-Intercepted-Call" has the following comment: "Release cause coded in \[31\] format". In case later version than the given one indicated for ISDN spec ETSI EN 300 403-1 has modified format of the "release cause", keeping the reference version specific allows to take proper actions in later versions of this specification.](#)

**\*\*\*\* Next Change \*\*\*\***

---

## 5 Circuit-switch domain

For North America the use of J-STD-~~25-025~~-A [23] is recommended.

**\*\*\*\* Next Change \*\*\*\***

### 6.2.3 Reliability

The reliability associated with the result of interception should be (at least) equal to the reliability of the original content of communication. This may be derived from the QoS class used for the original intercepted session [720].

Reliability from the NWOs/APs/SvPs to the LEMF is determined by what NWOs/APs/SvPs and law enforcement agree upon.

**\*\*\*\* Next Change \*\*\*\***

## 6.5 IRI for packet domain

Intercept related information will in principle be available in the following phases of a data transmission:

1. At connection attempt when the target identity becomes active, at which time packet transmission may or may not occur (set up of a data context, target may be the originating or terminating party);
2. At the end of a connection, when the target identity becomes inactive (removal of a data context);
3. At certain times when relevant information are available.

In addition, information on non-transmission related actions of a target constitute IRI and is sent via HI2, e.g. information on subscriber controlled input.

The intercept related information may be subdivided into the following categories:

1. Control information for HI2 (e.g. correlation information);
2. Basic data context information, for standard data transmission between two parties.

The events defined in [ref-\[419\]](#) are used to generate records for the delivery via HI2.

There are eight different event types received at DF2 level. According to each event, a Record is sent to the LEMF if this is required. The following table gives the mapping between event type received at DF2 level and record type sent to the LEMF.

**\*\*\*\* Next Change \*\*\*\***

## 6.5.1 Events and information

This clause describes the information sent from the Delivery Function (DF) to the Law Enforcement Monitoring Facility (LEMF) to support Lawfully Authorized Electronic Surveillance (LAES). The information is described as records and information carried by a record. This focus is on describing the information being transferred to the LEMF.

The IRI events and data are encoded into records as defined in the Table 6-1 Mapping between GPRS Events and HI2 records type and Annex B.3 Intercept related information (HI2) ~~+~~. IRI is described in terms of a 'causing event' and information associated with that event. Within each IRI Record there is a set of events and associated information elements to support the particular service.

**\*\*\*\* Next Change \*\*\*\***

## 7.2.1 Events and information

This clause describes the information sent from the Delivery Function (DF) to the Law Enforcement Monitoring Facility (LEMF) to support Lawfully Authorized Electronic Surveillance (LAES). The information is described as records and information carried by a record. This focus is on describing the information being transferred to the LEMF.

The IRI events and data are encoded into records as defined in the Table 7-1 Mapping between IMS Events and HI2 Records Type and Annex B.3 Intercept related information (HI2) ~~+~~. IRI is described in terms of a 'causing event' and information associated with that event. Within each IRI Record there is a set of events and associated information elements to support the particular service.

**\*\*\*\* Next Change \*\*\*\***

### A.1.2.1 Sending part

To request the sending of data to a peer entity, the LI\_Application provides the ASE\_HI, the address of the peer entity, the nature of the data and the data.

On receiving a request of the LI\_Application:

- If the data link toward the peer entity address is active, the ASE\_HI, from the nature of the data provided, encapsulates this data in the relevant RO-Invoke operation.
- If the data link toward the peer entity address isn't active, the ASE\_HI reports the data link unavailability to the LI Application.

NOTE: Until the data link is established according to A.1.2.3.1, the request of the LI\_Application cannot be successfully processed by ASE\_HI.

Depending on the natures of the data provided by the LI\_Application, the ASE\_HI encapsulates this data within the relevant ROSE operation:

- IRI: in this case the data provided by the application are encoded within the class 2 RO-Invoke operation *Umts\_Sending\_of\_IRI*.

The following section has been included only for backward compatibility reasons towards [earlier versions of ETSI ES 201-671](#) [24]:



- User packet data transfer (used for data, which can be exchanged via ISUP/DSS1/MAP signalling: e.g. UUS, SMS): in this case the data provided by the application are encoded:
  - either within the class 2 RO-Invoke operation "Circuit-Call-related-services" in case of data associated to a circuit call (e.g. for UUS 1 to 3). The ASN.1 format is described in clause B.5 (HI3 interface);
  - or within the class 2 RO-Invoke operation "No-Circuit-Call-related-services" in case of data not associated with a circuit call (e.g. for SMS). The ASN.1 format is described in clause B.5 (HI3 interface).

Depending on the class of the operation, the ASE-HI may have to wait for an answer. In this case a timer, depending on the operation, is started on the sending of the operation and stopped on the receipt of an answer (RO\_Result, RO\_Error, RO\_Reject).

**\*\*\*\* Next Change \*\*\*\***

## B.3 Intercept related information (HI2)

```
GPRSEvent ::= ENUMERATED
{
  pDPContextActivation          (1),
  startOfInterceptionWithPDPCContextActive (2),
  pDPContextDeactivation       (4),
  gPRSAttach                   (5),
  gPRSDetach                   (6),
  locationInfoUpdate           (10),
  SMS                          (11),
  pDPContextModification       (13),
  servingSystem                (14),
  ...
}
-- see ref-[1019]
```

**\*\*\*\* Next Change \*\*\*\***

```
UmtsQos ::= CHOICE
{
  qosMobileRadio [1] OCTET STRING,
  -- The qosMobileRadio parameter shall be coded in accordance with the § 10.5.6.5 of
  -- document [9] or [21] without the Quality of service IEI and Length of
  -- quality of service IE (. That is, first
  -- two octets carrying 'Quality of service IEI' and 'Length of quality of service
  -- IE' shall be excluded).
  qosGn [2] OCTET STRING
  -- qosGn parameter shall be coded in accordance with § 7.7.34 of document [17]
}
```

**\*\*\*\* Next Change \*\*\*\***

### C.1.2 Definition of ULIC header version 0

ULIC header contains the following attributes:

- Correlation Number.
- Message Type (a value of 255 is used for HI3-PDU's).
- Direction.
- Sequence Number.

- Length.

T-PDU contains the intercepted information.

Octets	Bits							
	8	7	6	5	4	3	2	1
1	Version ('0 0 0')			'1'	Spare '1 1'		DIR	'0'
2	Message Type (value 255)							
3-4	Length							
5-6	Sequence Number							
7-8	not used (value 0)							
9	not used (value 255)							
10	not used (value 255)							
11	not used (value 255)							
12	not used (value 255)							
13-20	correlation number							

Figure C.1: Outline of ULIC header

For interception tunneling the ULIC header shall be used as follows:

- Version shall be set to 0 to indicate the first version of ULIC header.
- DIR indicates the direction of the T-PDU:
  - "1" indicating uplink (from observed mobile user); and
  - "0" indicating downlink (to observed mobile user).
- Message Type shall be set to 255 (the unique value that is used for T-PDU within GTP [4217]).
- Length shall be the length, in octets, of the signalling message excluding the ULIC header. Bit 8 of octet 3 is the most significant bit and bit 1 of octet 4 is the least significant bit of the length field.
- Sequence Number is an increasing sequence number for tunneled T-PDUs. Bit 8 of octet 5 is the most significant bit and bit 1 of octet 6 is the least significant bit of the sequence number field.
- Correlation Number consists of two parts: GGSN-ID identifies the GGSN which creates the Charging-ID.

Charging-ID is defined in [4217] and assigned uniquely to each PDP context activation on that GGSN (4 octets).

The correlation number consist of 8 octets. The requirements for this correlation number are similar to that defined for charging in [4217], chapter 5.4. Therefore it is proposed to use the Charging-ID, defined in [4217] ; chapter 5.4 as part of correlation number. The Charging-ID is signaled to the new SGSN in case of SGSN-change so the tunnel identifier could be used "seamlessly" for the HI3 interface.

0				1				2				3										
0	1	2	3	4	5	6	7	8	9	0	1	2	3	4	5	6	7	8	9	0	1	
Charging -ID				Charging -ID				Charging -ID				Charging -ID				Octet 13-16						
Octet 1				Octet 2				Octet 3				Octet 4										
GGSN-ID																				Octet 17-20		

Figure C.2: Outline of correlation number

## Annex E (informative): Bibliography

The following material, though not specifically referenced in the body of the present document (or not publicly available), gives supporting information.

1. ITU-T Recommendation X.25: "Interface between Data Terminal Equipment (DTE) and Data Circuit-terminating Equipment (DCE) for terminals operating in the packet mode and connected to public data networks by dedicated circuit".
- ~~2. EN 300 356-1 to -20: "Integrated Services Digital Network (ISDN); Signalling System No.7; ISDN User Part (ISUP) version 3 for the international interface; Parts 1 to 20".~~
- ~~3. EN 300 403-1 (V1.2): "Integrated Services Digital Network (ISDN); Digital Subscriber Signalling System No. one (DSS1) protocol; Signalling network layer for circuit mode basic call control; Part 1: Protocol specification [ITU-T Recommendation Q.931 (1993), modified]".~~
4. EN 300 061-1: "Integrated Services Digital Network (ISDN); Subaddressing (SUB) supplementary service; Digital Subscriber Signalling System No. one (DSS1) protocol; Part 1: Protocol specification".
5. EN 300 097-1 including Amendment 1: "Integrated Services Digital Network (ISDN); Connected Line Identification Presentation (COLP) supplementary service; Digital Subscriber Signalling System No. one (DSS1) protocol; Part 1: Protocol specification".
6. EN 300 098-1: "Integrated Services Digital Network (ISDN); Connected Line Identification Restriction (COLR) supplementary service; Digital Subscriber Signalling System No. one (DSS1) protocol; Part 1: Protocol specification".
7. EN 300 130-1: "Integrated Services Digital Network (ISDN); Malicious Call Identification (MCID) supplementary service; Digital Subscriber Signalling System No. one (DSS1) protocol; Part 1: Protocol specification".
8. EN 300 138-1 including Amendment 1: "Integrated Services Digital Network (ISDN); Closed User Group (CUG) supplementary service; Digital Subscriber Signalling System No. one (DSS1) protocol; Part 1: Protocol specification".
9. EN 300 185-1: "Integrated Services Digital Network (ISDN); Conference call, add-on (CONF) supplementary service; Digital Subscriber Signalling System No. one (DSS1) protocol; Part 1: Protocol specification".
10. ETS 300 188-1: "Integrated Services Digital Network (ISDN); Three-Party (3PTY) supplementary service; Digital Subscriber Signalling System No. one (DSS1) protocol; Part 1: Protocol specification".
11. EN 300 207-1 (V1.2): "Integrated Services Digital Network (ISDN); Diversion supplementary services; Digital Subscriber Signalling System No. one (DSS1) protocol; Part 1: Protocol specification".
12. EN 300 286-1: "Integrated Services Digital Network (ISDN); User-to-User Signalling (UUS) supplementary service; Digital Subscriber Signalling System No. one (DSS1) protocol; Part 1: Protocol specification".
13. EN 300 369-1 (V1.2): "Integrated Services Digital Network (ISDN); Explicit Call Transfer (ECT) supplementary service; Digital Subscriber Signalling System No. one (DSS1) protocol; Part 1: Protocol specification".
14. EN 300 196-1 (V1.2): "Integrated Services Digital Network (ISDN); Generic functional protocol for the support of supplementary services; Digital Subscriber Signalling System No. one (DSS1) protocol; Part 1: Protocol specification".
15. ITU-T Recommendation Q.850: "Usage of cause and location in the Digital Subscriber Signalling System No. 1 and the Signalling System No. 7 ISDN User Part".
16. ITU-T Recommendation X.881: "Information technology - Remote Operations: OSI realizations - Remote Operations Service Element (ROSE) service definition".
- ~~17. ITU-T Recommendation X.882: "Information technology - Remote Operations: OSI realizations - Remote Operations Service Element (ROSE) protocol specification".~~

18. EN 300 122-1: "Integrated Services Digital Network (ISDN); Generic keypad protocol for the support of supplementary services; Digital Subscriber Signalling System No. one (DSS1) protocol; Part 1: Protocol specification".
19. ETS 300 392-1: "Terrestrial Trunked Radio (TETRA); Voice plus Data (V+D); Part 1: General network design".
20. EN 301 344, GSM 03.60: "Digital cellular telecommunications system (Phase 2+); GPRS Service description stage 2".
21. RFC-2228: "FTP Security Extensions", October 1997.
22. Void.
23. ETSI TR 101 876 "Telecommunications security; Lawful Interception (LI); Description of GPRS HI3".
24. [ETSI ES 201 671: "Handover Interface for the lawful interception of telecommunications traffic"](#).

J.2.3.2 Field order and layout

Table J.2.6: Calling Party Subaddress

Bits								Octets
8	7	6	5	4	3	2	1	
Calling party subaddress identifier								1
Length of calling party subaddress contents								2
Type of subaddress = user specified, odd/even indicator according to the amount of BCD-digits								3
LIID ②				LIID ①				4
LIID ④				LIID ③				5
LIID ⑥				LIID ⑤				6
LIID ⑧				LIID ⑦				7
LIID ⑩				LIID ⑨				8
LIID ⑫				LIID ⑪				9
LIID ⑭				LIID ⑬				10
LIID ⑯				LIID ⑰				11
LIID ⑲				LIID ⑱				12
LIID ⑳				LIID ㉑				13
LIID ㉒				LIID ㉓				14
LIID ㉔				LIID ㉕				15
Field separator				LIID ㉖				16
Field separator				Direction				17
spare				spare				18
ITU-T Recommendation Q.763 [3233] TMR (see note 1)								19
ITU-T Recommendation Q.931 BC [3334] octet 3 (see note 2)								20
ITU-T Recommendation Q.931 HLC [3334] octet 4 (see note 3)								21
Mobile Bearer Service Code (see note 4)								22
Mobile Teleservice Code (see note 5)								23
NOTE 1: If available, the Transmission Medium Requirement according to EN 300 356 [2930]. If not available, the value is "FF" hex.								
NOTE 2: If available, only octet 3 of the Bearer Capability I.E. according to EN 300 403 [3031] If not available, the value is "FF" hex.								
NOTE 3: If available, only octet 4 of the High Layer Compatibility I.E. according to EN 300 403 [3031]. If not available, the value is "FF" hex.								
NOTE 4: If available, the Mobile Bearer Service Code according to ETS 300 974 [34] [4], clause 44.17.7.10. If not available, the octets 22 and 23 shall not be transmitted.								
NOTE 5: If available, the Mobile Teleservice Code according to ETS 300 974 [34] [4], clause 44.17.7.9. If not available, the octet 23 shall not be transmitted.								