

Source: MCC
Title: Overview of 3GPP Release 99
Document for: Information/comments¹
Agenda Item: 8

Overview of 3GPP Release 99

Summary of all Release 99 Features

¹ Comments should be sent by e-mail to alain.sultan@etsi.org using the title "Comment to the Rel-99 document"

Credits

This document has been produced by the ETSI MCC department, headed by Adrian Scrase and then by John Meredith, who translated this document from international English to proper English. The technical experts of MCC who contributed to this document are namely Claude Arzelier (coordinator of the RAN aspects), Friedhelm Rodermund (for Terminal and USIM aspects), Paolo Usai (for Codec and GERAN aspects), Alain Sultan (for Architectural and Testing aspects), Adrian Zoicas, Andrijana Jurisic, Cesar Gutierrez, David Boswarthick, Joern Krause, Kimmo Kymalainen, Michael Clayton, Per Johan Jorgensen and Maurice Pope. The work was coordinated by Alain Sultan, who wishes to acknowledge all contributors for the high quality of their inputs.

Table of Content

1	INTRODUCTION.....	5
1.1	SCOPE.....	5
1.2	REFERENCES	5
1.2.1	<i>Specifications</i>	5
1.2.2	<i>Tdocs</i>	6
1.2.3	<i>Change Request database</i>	6
2	UMTS FEATURES.....	6
2.1	ARCHITECTURE OF THE GSM-UMTS PLATFORM	6
2.2	THE UMTS TERRESTRIAL RADIO ACCESS NETWORK.....	10
2.3	MANDATORY SPEECH CODEC FOR NARROWBAND TELEPHONY SERVICE	16
2.4	CODEC FOR LOW BITRATE MULTIMEDIA TELEPHONY SERVICE	18
2.5	3G AUDIO-VISUAL TERMINAL CHARACTERISTICS.....	19
3	UMTS AND GSM FEATURES.....	20
3.1	MULTIMEDIA MESSAGING SERVICE	20
3.2	LOCATION SERVICES.....	20
3.3	CAMEL PHASE 3	24
3.3.1	<i>Global view</i>	24
3.3.2	<i>Multiple Subscriber Profile (MSP) based on CAMEL phase 3</i>	25
3.4	SHORT MESSAGE SERVICE ENHANCEMENTS	25
3.5	MOBILE STATION EXECUTION ENVIRONMENT	25
3.6	MULTICALL.....	27
3.7	OPEN SERVICE ARCHITECTURE	28
3.8	SUPER CHARGER	29
3.9	FOLLOW ME	30
3.10	SYNCHRONISATION AND OBJECT EXCHANGE	31
3.11	TERMINAL INTERFACES.....	31
3.11.1	<i>AT commands for 3GPP</i>	31
3.11.2	<i>Physical interfaces</i>	32
3.11.3	<i>Multiplexer</i>	32
3.12	BEARER SERVICES	32
3.12.1	<i>Circuit Switched Bearer Services</i>	32
3.12.2	<i>Frame Tunnelling Mode</i>	33
3.12.3	<i>Access to ISPs and Intranets – Wireless/Remote access to LANs</i>	34
3.12.4	<i>PHS Internet Access Forum Specification</i>	34
3.13	UICC AND USIM RELATED FEATURES.....	35
3.13.1	<i>UICC / Terminal interface; Physical and logical characteristics</i>	35
3.13.2	<i>Characteristics of the USIM application</i>	36
3.13.3	<i>UICC Application Identifiers</i>	36
3.13.4	<i>USIM Application Toolkit</i>	37
3.13.5	<i>Specification of a bearer independent protocol for SAT applications to exchange data over the GSM network</i>	38
3.13.6	<i>Specification of administrative commands and functions for IC cards</i>	38
3.13.7	<i>USIM and UICC requirements</i>	39
3.14	SECURITY RELATED FEATURES	39
3.14.1	<i>Fraud Information Gathering Service</i>	39
3.14.2	<i>Immediate Service Termination</i>	40
4	GSM FEATURES	40
4.1	DUAL TRANSFER MODE WITHIN GSM AND GPRS.....	40

4.2	GENERAL PACKET RADIO SERVICE ENHANCEMENTS	41
4.3	GSM ON 400 MHZ FREQUENCY BAND.....	42
4.4	ENHANCED DATA RATES FOR GSM EVOLUTION.....	43
4.4.1	<i>Enhanced GPRS</i>	44
4.4.2	<i>Enhanced Circuit Switched Data</i>	45
4.4.3	<i>Support for EGPRS in ANSI-136 networks” and “EDGE Compact” (for ANSI-136 networks only)</i> 47	
4.4.3.1	Framework	47
4.4.3.2	EDGE Compact	48
5	CHARGING AND TESTING.....	48
5.1	CHARGING.....	48
5.2	OPERATIONS, ADMINISTRATION, MAINTENANCE AND PROVISIONING	49
5.3	USIM/UICC TESTING.....	50
5.3.1	<i>Terminal tests for the UICC Interface</i>	50
5.3.2	<i>USIM application test specification</i>	50
5.3.3	<i>USIM conformance test specification</i>	51
5.3.4	<i>SIM toolkit test specification</i>	51
5.4	3G USER EQUIPMENT (UE) TESTING.....	51
6	GSM FEATURES TRANSPOSED TO UMTS.....	53
6.1	CELL BROADCAST SERVICE.....	53
6.2	GSM MOBILE NUMBER PORTABILITY EURO MNP / NORTH AMERICAN MNP	53
6.3	AUTOMATIC ESTABLISHMENT OF ROAMING RELATIONS	53
6.4	ADVANCED ADDRESSING	54
6.5	UMTS NUMBERING, ADDRESSING AND IDENTITIES	54
6.6	LAWFUL INTERCEPTION	55
7	“FEATURES” NOT BRINGING ANY ADDITIONAL SERVICE.....	55
7.1	REPORTS.....	55
7.1.1	<i>Quality of Service</i>	55
7.1.2	<i>Noise Suppression for AMR</i>	56
7.1.3	<i>User Equipment Capability Requirements</i>	57
7.1.4	<i>Electrical safety requirements and regulations</i>	57
7.1.5	<i>Specific Absorbtion Rate (SAR) requirements and regulations in different regions</i>	58
7.1.6	<i>Multi-mode UE issues</i>	58
7.1.7	<i>QoS for Speech and Multimedia Codec</i>	58
7.2	FEASIBILITY STUDIES.....	59
7.3	OTHER SYSTEM IMPROVEMENTS	59
7.4	FEATURES DELETED OR MOVED TO LATER RELEASE	60
7.5	“HOLLOW” FEATURES	60
7.6	FEATURES FOR WHICH THERE IS NO INFORMATION, ASSUMED TO BE ABANDONED AND NOT IMPLEMENTABLE.....	61

1 Introduction

1.1 Scope

This document contains a high-level description of the Release 99 Features of the 3rd Generation Mobile System developed within 3GPP. It is part of a series of documents developed by MCC to provide a complete overview of the technical content of each Release.

A Feature is defined as a new or substantially enhanced functionality which represents added value to the existing system (see 3GPP TR 21.900). A feature should normally embody an improved service to the customer and / or increased revenue generation potential to the supplier.

Features are as independent as possible from each other, and relationships between features are clarified here.

The concept and definition of “Feature” was introduced in Release 4, i.e. in the Release following Release 99. When elaborating this document, MCC has applied the “feature” concept to the work done for Release 99, so the “Release 99 Features” are introduced by this document and were not officially defined as such by 3GPP. Also, the use of the 3GPP Work Plan was introduced in Release 4, i.e. there was no official tracking of the work progress in Release 99, so this document was written from a detailed review of all specifications, change requests, meeting contributions and reports, etc.

The features have been grouped in different sections:

- UMTS features,
- features applicable to both GSM and UMTS,
- GSM features,
- charging and testing activities²,
- GSM features transposed to UMTS and
- “Features” not bringing any additional service.

For each feature (or independent item), references are given to guide the reader on how to deepen his knowledge of the subject: the Work Item Description (WID), when available, as well as the list of impacted specifications are provided in the beginning of the section describing the feature. Only the list of impacted specifications is provided here. The exact impact on a given specification due to a given feature is described in the Change Request (CR) list which can be found at the end of the specification, or in the CR database, which provides the full list of CRs for all 3GPP specifications. All this information is available on the 3GPP web site, as described below.

The second part of this introduction contains global references, and provides links to the 3GPP Specifications, the temporary documents (tdocs), the Work Item Descriptions (WIDs) and the CR database.

The main body of this document is structured according to the 3GPP Release 99 Features: each section corresponds to one Release 99 Feature, grouped as described above.

1.2 References

1.2.1 Specifications

Global information on the Specifications (also called “specs”) can be found at:

<http://www.3gpp.org/specs/specs.htm>

The latest versions of all 3GPP specifications, containing the most recent corrections and additions, are available at:

<http://www.3gpp.org/ftp/Specs/latest/>

² Given the definition of a “Feature”, charging and testing activities can hardly be seen as Features but as constituent (or “Building Blocks”) of Features.

For specific purposes, older versions might be needed. These versions are available at:

<http://www.3gpp.org/ftp/Specs/Archive/>

where the specifications are sorted by series and then by folders containing all the available versions of a given spec (one folder per spec), for all Releases.

1.2.2 Tdocs

The Temporary Documents (tdocs) are mainly the original papers written by the 3GPP Members, and are the inputs to the technical groups which develop the specs. They are available (sorted by 3GPP Technical Specification Groups (TSGs) and Working Groups (WGs) at:

<http://www.3gpp.org/ftp/>

in subdirectories starting with 'tsg....'.

1.2.3 Change Request database

A specification is originally drafted and maintained by a "rapporteur" (the editor), who compiles the contents from discussions in the WGs and TSGs. When it is considered to be 80% complete, it is brought under "change control". Thereafter, changes to the specification can only be made using Change Requests that are usually agreed by consensus in the Working Group responsible for the specification, and then formally approved by the relevant Technical Specification Group³.

The Change Request database contains all available information on Change Requests, including a Work Item code, a Change Request number that is unique within the specification (different versions are possible, but only one version can ever be approved), the status of each Change Request and references to relevant temporary document numbers and meetings. This database is available at:

http://www.3gpp.org/ftp/Information/Databases/Change_Request/CR-data.zip

Further information on CR is available at:

<http://www.3gpp.org/specs/CR.htm>

2 UMTS Features

2.1 Architecture of the GSM-UMTS Platform⁴

No acronym

References for WI " Architecture of the GSM-UMTS Platform "

Document	Title/Contents
SMG 98-0228	WI Sheets "Architecture overview of the GSM-UMTS System", "Architecture the GSM-UMTS Platform" and "New Access Network to Core Network (BSS-NSS) interface"
Impacted Specifications	
TS 23.002	Network architecture
TS 23.060	General Packet Radio Service Service description; Stage 2
TS 23.008	Organisation of subscriber data
New Dedicated Specifications	
TS 23.101	General UMTS Architecture
TS 23.110	UMTS Access Stratum Services and Functions

³ For a complete description on the handling of Specs and CRs at 3GPP, see the presentation in: <http://www.3gpp.org/ftp/Information/presentations/>

⁴ Despite its name, this feature has been classified under the section on UMTS-only features as nothing was changed for GSM.

UMTS (Universal Mobile Telecommunication System) refers to the interconnection of a new type of Access Network (AN), the UTRAN (UMTS Terrestrial Radio Access Network) to the adapted pre-Release 99 GSM/GPRS Core Network (CN) infrastructure. The UTRAN and its new bearer services are described in the next clause.

A basic requirement for Release 99 UMTS was to minimise the impacts on the Core Network when introducing the UTRAN. This principle was achieved to a great extent. The biggest impacts are the creation of a new type of interface between core and access networks, and the “upgrading” of the CN signalling to take into account the new capabilities offered by the UTRAN.

This section describes the UMTS network, using a top-down approach: the network is logically divided in a number of sets, both from the architectural aspect and from the protocols aspect. From the architectural point of view, the sets are called “domains” (a domain is a group of entities). From the protocols point of view, the sets are called “strata” (a stratum is a group of protocols). These principles, introduced for first time in UMTS, could also apply to GSM (and, indeed, to other types of network)

. They do not correspond to any concrete realisation in the network but were established mainly to organise the work as to allow different groups of people to work in parallel, each one being responsible for one (or several) domain(s) and/or stratum(a).

The domains are:

- the User Equipment domain, containing the elements the end-user carries with him, composed of:
 - o the Mobile Equipment domain (the “phone”), containing the radio transmitting/receiving device (in the Mobile Termination, MT) and the application (in the Terminal Equipment, TE), defined by 3GPP T2 group, and
 - o the USIM domain, typically embedded in an IC card, defined by 3GPP T3 group.
- the Infrastructure domain, i.e. the set of all the network entities, composed of:
 - o the Access Network domain, comprising all the entities closely related to the radio technology, defined by 3GPP RAN1 to RAN4 groups and
 - o the Core Network domain, defined by 3GPP CN1 to CN4 groups, composed of:
 - the Serving Network domain, composed of
 - the Circuit Switched (CS) domain
 - the Packet Switched (PS) domain
 - the Transit Network domain (potentially composed of CS and PS also), and
 - the Home Network domain, containing permanently all the user specific data and responsible for management of subscription information.

The domains are shown in the following figure:

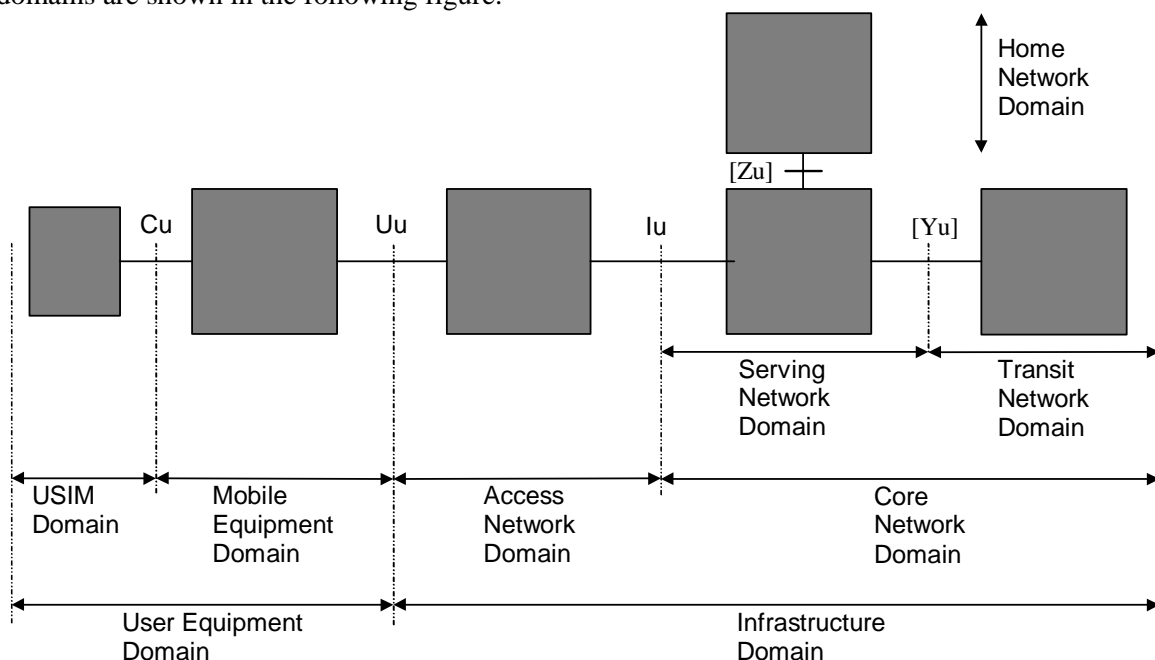

UMTS domains and reference points

The strata are:

- the Transport stratum, supporting the transport of user data and network control signalling from other strata through UMTS. It encompasses the Access Stratum, which is the part of the transport stratum located between the edge node of the serving core network domain and the MT;
- the Home stratum, which contains the protocols and functions related to the handling and storage of subscription data and possibly home network specific services;
- the Serving stratum, which consists of protocols and functions to route and transmit data/information, user or network generated, from source to destination; and
- the Application stratum, which represents the application process itself, provided to the end-user. It includes end-to-end protocols and functions which make use of services provided by the home, serving and transport strata and infrastructure to support services and/or value added services.

The connection between domains is a network interface or a reference point⁵, the connection between strata is a service primitive (which may use a standardised Service Access Point Identifier or may not be subject to standardisation) , which is internal to a network node.

Further definition of the domains and strata as well as their relationship is given in TS 23.101.

The next step in the network description is the division between “entities” and “protocols”: a domain is a group of (potentially just one) entities, a stratum is a group of (potentially just one) protocols.

UMTS introduces new entities⁶ in the AN - all the UTRAN entities are new, as described in the corresponding section - but not in the CN. The connection between entities is network interface or reference point. The following figure, extracted from TS 23.002, shows the UMTS and GSM Network Architecture.

⁵ “network interface” refers to a physical interface whereas a “reference point” can be physically composed of zero, one or several physical interface(s), as e.g. the Iu, which is a reference point composed of the Iu_CS and the Iu_PS interfaces.

⁶ With respect to entities definition, the standard assumes that an entity performs a given (set of) function(s) and offers a given (set of) interface(s) but the entity can also be further split into a group of non-standardised “smaller” entities, as long as the external interfaces are compliant to the ones defined in the standard.

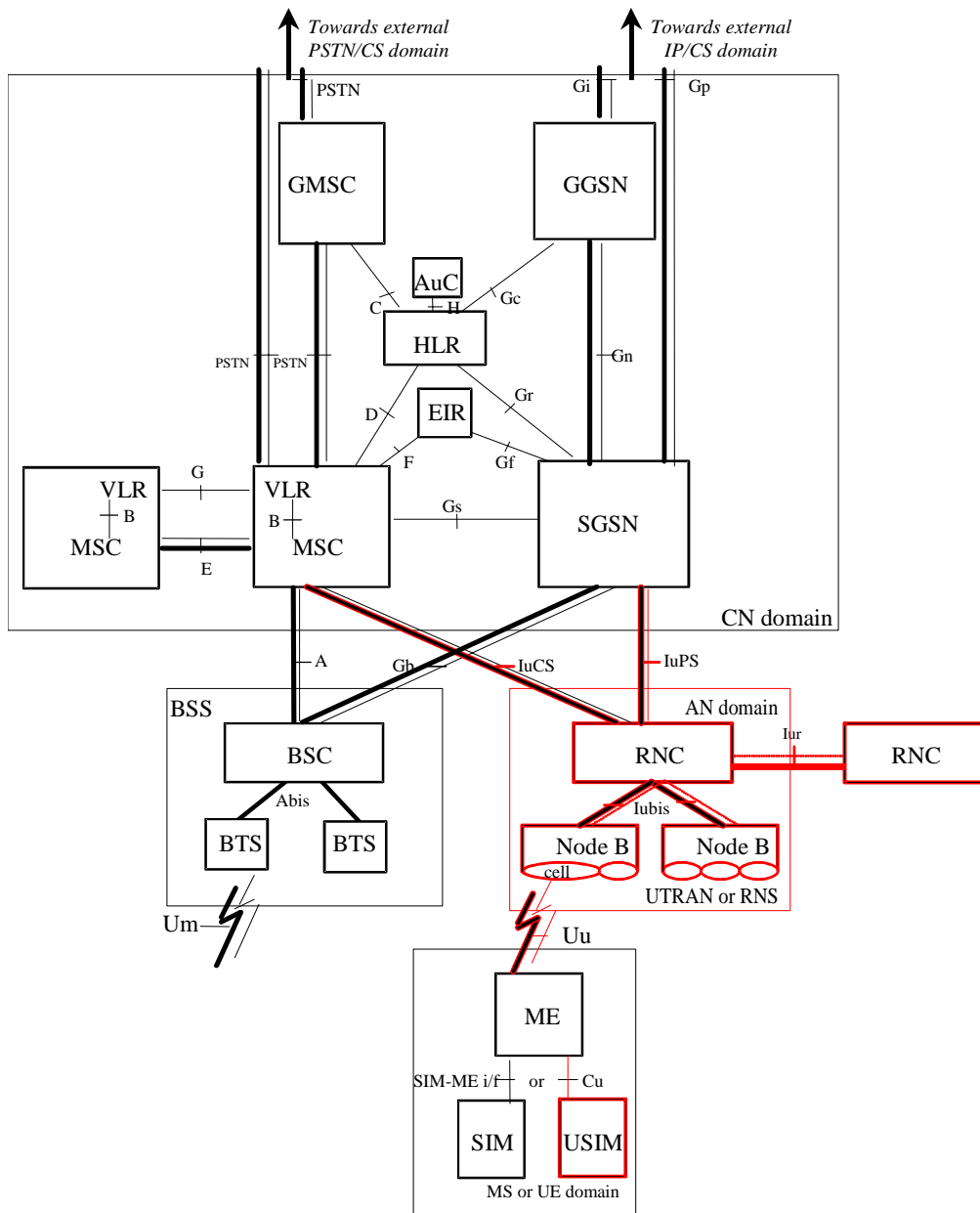

UMTS and GSM Network Architecture

Legend:

Bold lines: interfaces supporting application traffic (also called “user data”);

Dashed/thin lines: interfaces supporting signalling.

Red lines and boxes: interfaces and entities specific to UMTS

UMTS and GSM Network Architecture

Turning to protocols, again new protocols are introduced for the UTRAN (see corresponding section) but not for the CN, where the impacts are limited to modifications to the existing protocols, in particular the Mobile Application Part (MAP) defined in TS 29.002.

The functions performed by the UTRAN are different from those of the GSM BSS, in particular for the PS domain, so the nature of the interface between the CN and the AN is also different. The split of functions between CN and UTRAN, and a description of the transport services expected to be provided by the UTRAN to the rest of the network, are subject to a dedicated specification, TS 23.110. In the CS domain, the differences between GSM and UMTS are not particularly relevant (GSM’s A interface is quite similar to the UMTS’ Iu_CS interface) whereas in the PS domain, the UMTS’ Iu_PS offers “connections” (called “Iu

Bearers”) contrarily to GSM’s Gb interface. This is an important milestone for enabling future support of end-to-end Quality of Service in PS domain, although this is not supported in this Release.

2.2 The UMTS Terrestrial Radio Access Network

Acronym: UTRAN

References for WI " UMTS Terrestrial radio access network (UTRAN)"

Document	Title/Contents
WIDs	
	No WI for the introduction of the UTRAN
Impacted Specifications	
TS 22.038	(U)SIM Application Toolkit (USAT/SAT); Service description; Stage 1
TS 22.060	General Packet Radio Service (GPRS); Service description, Stage 1
TS 22.078	Customised Applications for Mobile network Enhanced Logic (CAMEL); Service description, Stage 1
TS 22.101	Service aspects; Service principles
TS 22.105	Service aspects; Services and Service Capabilities
TS 22.115	Service aspects; Charging and billing
TS 22.011	Group Services and System Aspects; Service accessibility
TS 23.002	Group Services and Systems Aspects; Network architecture
TS 23.060	Group Services and System Aspects; General Packet Radio Service (GPRS); Service description; Stage 2
TS 24.007	Group Core Network; Mobile radio interface signalling layer 3; General aspects
TS 24.008	Group Core Network; Mobile radio interface layer 3 specification; Core Network Protocols; Stage 3
	This list is not exhaustive.
New Dedicated Specifications	
<i>UTRAN layer 1 (RAN1)</i>	
TS 22.100	UMTS phase 1 Release 99
TS 22.129	Handover requirements between UTRAN and GERAN or other radio systems
TS 25.201	Physical layer - general description
TS 25.211	Physical channels and mapping of transport channels onto physical channels (FDD)
TS 25.212	Multiplexing and channel coding (FDD)
TS 25.213	Spreading and modulation (FDD)
TS 25.214	Physical layer procedures (FDD)
TS 25.215	Physical layer; Measurements (FDD)
TS 25.221	Physical channels and mapping of transport channels onto physical channels (TDD)
TS 25.222	Multiplexing and channel coding (TDD)
TS 25.223	Spreading and modulation (TDD)
TS 25.224	Physical layer procedures (TDD)
TS 25.225	Physical layer; Measurements (TDD)
TR 25.944	Channel coding and multiplexing examples
<i>UTRAN layer 2 and layer 3 Radio Resource (RAN2)</i>	
TS 25.301	Radio Interface Protocol Architecture
TS 25.302	Services provided by the physical layer
TS 25.303	Interlayer procedures in Connected Mode
TS 25.304	User Equipment (UE) procedures in idle mode and procedures for cell reselection in connected mode
TS 25.305	User Equipment (UE) positioning in Universal Terrestrial Radio Access Network (UTRAN); Stage 2
TS 25.306	UE Radio Access capabilities definition
TS 25.307	Requirements on UEs supporting a release-independent frequency band
TS 25.321	Medium Access Control (MAC) protocol specification

TS 25.322	Radio Link Control (RLC) protocol specification
TS 25.323	Packet Data Convergence Protocol (PDCP) specification
TS 25.324	Broadcast/Multicast Control (BMC)
TS 25.331	Radio Resource Control (RRC) protocol specification
TR 25.921	Guidelines and principles for protocol description and error handling
TR 25.922	Radio Resource Management Strategies
TR 25.993	Typical examples of Radio Access Bearers (RABs) and Radio Bearers (RBs) supported by Universal Terrestrial Radio Access (UTRA)
TR 25.925	Radio Interface for Broadcast/Multicast Services
TS 34.109	Terminal logical test interface; Special conformance testing functions
<i>UTRAN interfaces (RAN3)</i>	
TS 25.401	UTRAN Overall Description
TS 25.402	Synchronisation in UTRAN Stage 2
TS 25.410	UTRAN Iu Interface: General Aspects and Principles
TS 25.411	UTRAN Iu Interface Layer 1
TS 25.412	UTRAN Iu Interface Signalling Transport
TS 25.413	UTRAN Iu Interface RANAP Signalling
TS 25.414	UTRAN Iu interface data transport and transport signalling
TS 25.415	UTRAN Iu interface user plane protocols
TS 25.419	UTRAN Iu-BC interface: Service Area Broadcast Protocol (SABP)
TS 25.420	UTRAN Iur Interface General Aspects and Principles
TS 25.421	UTRAN Iur interface layer 1
TS 25.422	UTRAN Iur Interface Signalling Transport
TS 25.423	UTRAN Iur interface RNSAP signalling
TS 25.424	UTRAN Iur Interface Data Transport & Transport Signalling for Common Transport Channel Data Streams
TS 25.425	UTRAN Iur interface user plane protocols for Common Transport Channel data streams
TS 25.426	UTRAN Iur and Iub interface data transport & transport signalling for DCH data streams
TS 25.427	UTRAN Iub/Iur interface user plane protocol for DCH data streams
TS 25.430	UTRAN Iub Interface: General Aspects and Principles
TS 25.431	UTRAN Iub interface layer 1
TS 25.432	UTRAN Iub Interface: Signalling Transport
TS 25.433	UTRAN Iub interface NBAP signalling
TS 25.434	UTRAN Iub Interface Data Transport and Transport Signalling for Common Transport Channel Data Streams
TS 25.435	UTRAN Iub Interface User Plane Protocols for Common Transport Channel Data Streams
TS 25.442	UTRAN Implementation Specific O&M Transport
TS 29.108	Application of the Radio Access Network Application Part (RANAP) on the E-interface
TR 25.832	Manifestations of Handover and SRNS Relocation
TR 25.853	Delay Budget within the Access Stratum
TR 25.931	UTRAN Functions, Examples on Signalling Procedures
<i>UTRAN RF parameters & performance requirements (RAN4)</i>	
TS 25.101	User Equipment (UE) radio transmission and reception (FDD)
TS 25.102	User Equipment (UE) radio transmission and reception (TDD)
TS 25.104	Base Station (BS) radio transmission and reception (FDD)
TS 25.105	UTRA (BS) TDD: Radio transmission and reception
TS 25.113	Base station and repeater electromagnetic compatibility (EMC)
TS 25.123	Requirements for support of radio resource management (TDD)
TS 25.133	Requirements for support of radio resource management (FDD)
TS 25.141	Base Station (BS) conformance testing (FDD)
TS 25.142	Base Station (BS) conformance testing (TDD)
TR 25.942	RF system scenarios
TS 34.124	Electromagnetic compatibility (EMC) requirements for Mobile terminals and ancillary equipment

While looking into data rates, the first phase of GPRS (Releases 97 and 98) allowed a maximum of 171,2 kbit/s (see TS 05.01). That was achievable by using all eight available timeslots, and in the best radio-traffic conditions. The radio interface used for UTRAN, a Wideband Code Division Multiple Access (W-CDMA), was originally designed to allow for the Release'99 a maximum (theoretical) peak rate of around 2 Mbits/s.

For this, a Direct-Sequence Code Division Multiple Access scheme was chosen. The figure below shows the process applied to the user information.

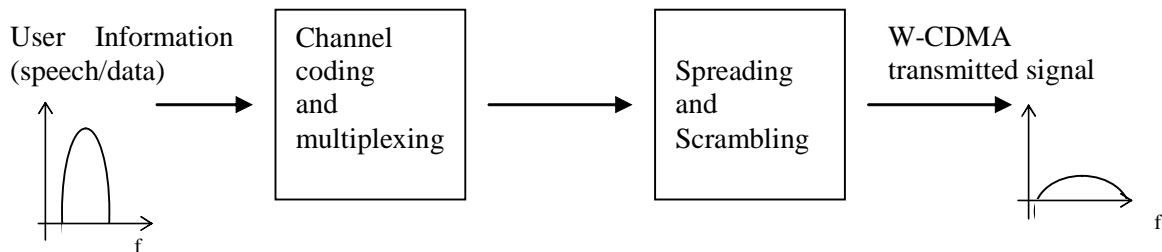

From user information to W-CDMA signal

The channel coding and multiplexing chain is variable and allows the system to "fit" the selected rate into the physical pipe, offering the flexibility to select a data rate versus the level of interference created. In other words, this gives the possibility of achieving a trade-off between network capacity, coverage and data/speech rate. The spreading multiplies in time the data sequence with a variety of CDMA spreading codes, creating the "wideband" dimension of the signal. The choice of the scrambling code ensures that the information relative to one user can be decoded while minimising interferences towards other users (orthogonality).

A simple example is provided here. Let's defined the three channels i, j , and k . Upon transmission, channel i transforms the user information's binary signal into:

$$1 \rightarrow C_i = (1, -1, -1, 1, -1, 1) \text{ and } -1 \rightarrow \bar{C}_i = (-1, 1, 1, -1, 1, -1).$$

Channel j is defined by $C_j = (1, 1, -1, -1, 1, 1)$ and channel k by $C_k = (1, 1, -1, 1, 1, -1)$.

Upon reception, the decoder for channel i is specified by $S_i = x_6 - x_5 - x_4 + x_3 - x_2 + x_1$ (i.e. using the coefficients of C_i). This decoder applied to a bit sequence received on channel i provides:

$$S_i(C_i) = (1 \times 1) + (-1 \times -1) + (-1 \times -1) + (1 \times 1) + (-1 \times -1) + (1 \times 1) = 6 \text{ and } S_i(\bar{C}_i) = -6$$

Whereas this decoder applied to a bit sequence received on another channel provides:

$$S_i(C_j) = S_i(\bar{C}_j) = S_i(C_k) = S_i(\bar{C}_k) = 0.$$

The speech codec chosen for UTRAN is suited to the data rate flexibility and can use different (up to eight) source rates, as mentioned in the clause on speech codecs.

The chip rate is 3,84 Mcps. This translates to an occupied bandwidth (99% of the total integrated power) of less than 5 MHz (see e.g. TS 25.101 or TS 25.102). Hence, the "Carrier spacing" is 5 MHz (compared to the 200 kHz of GSM/GPRS).

The larger occupied bandwidth of 5 MHz allows the system to benefit from the multipath nature of the radio propagation. At 3,84 Mcps, a receiver can separate the multipath components and combine them in a constructive way if the time difference between the two multipaths is at least of 0,26µs (a chip duration), i.e. 78 cm (as a reminder, the slot duration is 577 µs in GSM). This permits optimisation of the receivers to make the most of the diversity in the multipath propagation.

Two W-CDMA modes co-exist in UTRAN: the Frequency division duplex (FDD) mode and the Time division duplex (TDD) mode⁷. In the FDD mode, two different frequency bands are used for the uplink and downlink directions. The frequency separation between uplink and downlink, or duplex distance, is 190 MHz or 80 MHz in ITU-R Regions 1 or 2 (the use of other duplex distances is not precluded). In TDD mode, the same frequency is used for both the uplink and downlink directions: intended to operate in an unpaired spectrum, the direction of the transmission is alternated in time, which allows asymmetric traffic in uplink and downlink depending on the number of timeslots that are configured for each link.

At higher layers, the definitions of the two modes converge.

The demodulation is coherent, in other words an internal time reference is used. Either the Common Pilot Channel (CPICH) (for FDD) or the Dedicated Physical Control Channel (DPCCH) can be used (as a result, the Base Station and User Equipment (UE) do not need to be synchronised to a third party system).

The frequency of the carrier is shown in the table below (the exact spectrum available remains country-specific):

Frequency division duplex (FDD)		Time division duplex (TDD)	
Region 1 (e.g. Europe and Africa)		Region 1 (e.g. Europe and Africa)	
1920-1980 MHz	Uplink	1900 – 1920 MHz 2010 – 2025 MHz	Uplink and Downlink
2110-2170 MHz	Downlink		
Region 2 (e.g. America)		Region 2 (e.g. America)	
1850-1910 MHz	Uplink	1850 – 1910 MHz 1930 – 1990 MHz 1910 – 1930 MHz	Uplink and Downlink
1930-1990 MHz	Downlink		

While the Releases 97 and 98 GSM specifications only allowed up to two simultaneous Packet-Switched connections (one in the uplink and one in the downlink direction), the Radio Resource Management (RRM) of UTRAN offers the possibility to multiplex services with different quality requirements on a single connection, e.g. video, packet data and speech.

Selection of the properties of a radio bearer is possible, with its associated throughput, transfer delay (from real-time to best-effort) and data error rate (from 10% on frame error rate to 10^{-6} bit error rate). This is aimed at fulfilling different applications, having different Quality of Service (QoS) requirements. Furthermore, bearer reselection is possible when e.g. the system becomes overloaded (on a 10 ms frame duration - basis). Bearer reselection is one side of the load controls, in effect a load-based packet scheduling correlated with interferences, given by the nature of the UTRAN interface.

Due to the intrinsic correlation between load and interference within UTRAN, output powers and their variations are of prime essence for controlling/allowing the load/services within the cells. Hence, UTRAN has defined a power control, both in the uplink and downlink directions (e.g. in FDD it is controlled on a 1500 Hz basis; it was of a maximum of 2 Hz in GSM). The Network instructs the UE to go up/down in output power. The Base Station uses a target Signal-to-Interference Ratio (SIR) to adjust its output power. One of the prime goals of the power control is to compensate the "near-far" effect in the uplink direction: if a UE was not able to rapidly adjust its transmission it could cause, for example, an undesirable noise rise at the base station receiver.

The overall architecture of the radio access network is shown in the red elements of the figure on UMTS and GSM Network Architecture (in clause “Architecture of the GSM-UMTS Platform”).

The architecture of this radio interface consists of a set of radio network subsystems (RNSs) connected to the CN through the Iu interface. An RNS consists of a radio network controller (RNC) and one or more entities

⁷ Alternatively, W-CDMA is sometimes used to refer only to the FDD mode. In this case, TDD is said to use the TD-CDMA technology (Time Division – Code Division Multiple Access). In this document, W-CDMA is said to be the technology both for FDD and TDD.

called Node B. Node B is connected to the RNC through the Iub interface. Each Node B can handle one or more cells. The RNC is responsible for the handover decisions that require signalling to the user equipment (UE). The RNCs of the RNS can be interconnected through the Iur interface. Iu and Iur are logical interfaces, i.e. the Iur interface can be conveyed over a direct physical connection between RNCs or via any suitable transport network.

The figure “Radio Interface Protocol Architecture of the RRC Sublayer, L2 and L1” below shows the radio interface protocol architecture for the radio access network. On a general level, the protocol architecture is similar to the ITU-R protocol architecture as described in Rec. ITU-R M.1035. Layer 2 (L2) is split into the following sub-layers:

- Radio Link Control (RLC),
- Medium Access Control (MAC),
- Packet Data Convergence Protocol (PDCP), and
- Broadcast/Multicast Control (BMC).

Layer 3 (L3) and RLC are divided into control (C-plane) and user (U-plane) planes. In the C-plane, L3 is partitioned into sub-layers where the lowest sub-layer, denoted as radio resource control (RRC), interfaces with L2. The higher-layer signalling such as mobility management (MM) and call control (CC) are assumed to belong to the CN. There are no L3 elements in this radio interface for the U-plane.

Each block in this figure represents an instance of the respective protocol. Service access points (SAPs) for peer-to-peer communication are marked with circles at the interface between sub-layers. The SAP between MAC and the physical layer provides the transport channels. A transport channel is characterized by how the information is transferred over the radio interface.

The general classification of transport channels is into two groups:

- Common transport channels where there is a need for explicit UE identification when a particular UE or a particular group of UEs is addressed.
- Dedicated transport channels where a UE is implicitly identified by the physical channel, i.e. code and frequency.

The SAPs between RLC and the MAC sub-layer provide the logical channels. A logical channel is characterized by the type of information that is transferred over the radio interface. The logical channels are divided into control channels and traffic channels.

In the C-plane, the interface between RRC and higher L3 sub-layers (CC, MM) is defined by the general control (GC), notification (Nt) and dedicated control (DC) SAPs. These SAPs are not further discussed in this overview.

Also shown in the figure below are connections between RRC and MAC as well as RRC and L1 providing local inter-layer control services (including measurement results). An equivalent control interface exists between RRC and the RLC sub-layer. These interfaces allow the RRC to control the configuration of the lower layers. For this purpose separate control SAPs are defined between RRC and each lower layer (RLC, MAC, and L1).

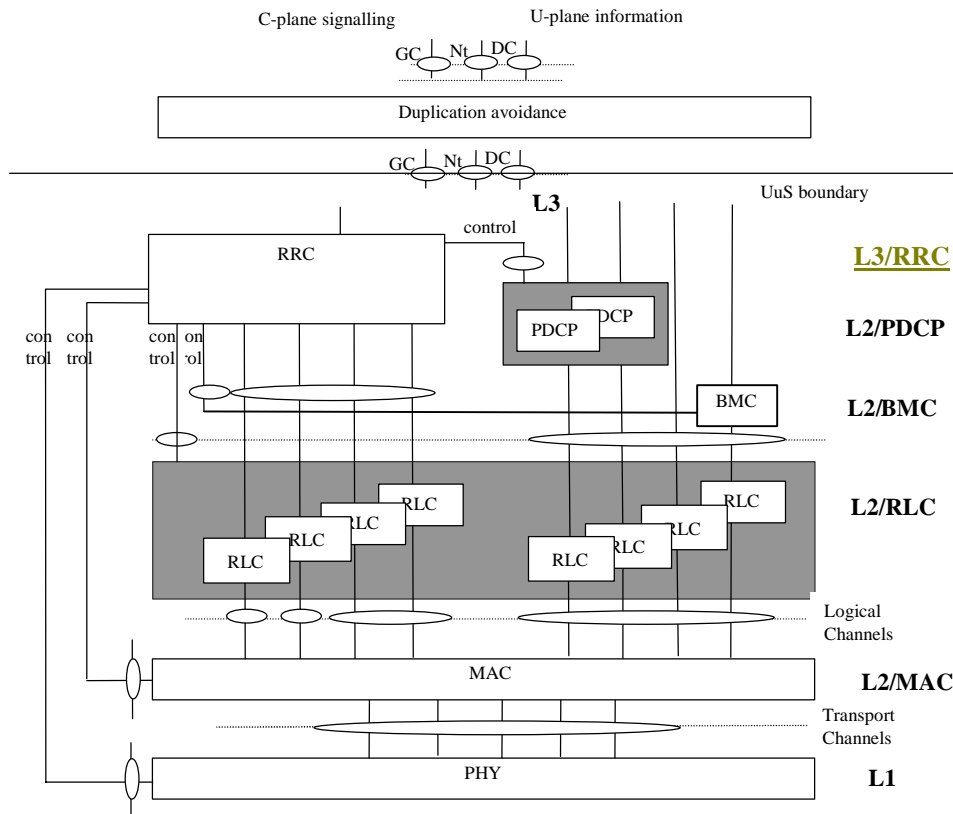

Radio Interface Protocol Architecture of the RRC Sublayer, L2 and L1

Within the Release 99 standards, a number of schemes are available to extract maximal functionality from the system:

Transmission diversity:

The purpose is mainly in order to improve the reception quality in the downlink direction (exploit diversity gain to reduce power consumption for radio links in the cell i.e. increase the downlink capacity). Two antennas are used at the Base Station, the UE combines the received signals. This is a form of spatial/antenna diversity (performance requirements on the final recombination are defined for the UE).

Soft handover used in the FDD mode:

In effect, the soft handover scheme is a form of macro diversity. Two sectors from two different base stations communicate simultaneously with the UE (i.e. two radio interface links are used, using two power control loops). Both signals are received and used by the UE. In the uplink direction, the Radio network controller (RNC) within the network selects the best frame, at each interleaving period (every 10-80 ms).

Softer handover used in the FDD mode:

In this case, the two sectors belong to the same base station. The two signals (using the same power control loop) can be combined within the receivers of the UE and the base station. Two separate codes are used in the downlink direction, so that the UE can separate the signals. The difference is that in the uplink direction, combining is performed within the same base station. This combining can be performed in the baseband receiver of the base station, in comparison with the more drastic selection in the RNC performed by the soft handover.

Compressed mode used in the FDD mode:

When parallel measurements to another UTRAN frequency or a GSM frequency has to be performed (for e.g. UE reporting, in order to allow handovers), a pure parallel measurement would require a dual receiver. The Compressed Mode avoids this complexity, by operating the receiver in a slotted mode leaving some time for the UE to perform measurement on another frequency.

The compressed mode is available in the uplink and downlink directions. Several transmission time reduction techniques are available to allow this creation of gaps: "spreading factor reduction by 2", "higher

layer scheduling" or "puncturing". The goal is to create "holes" in time, so that they can be used for measuring other frequencies. When this scheme is used, receiver and transmitter clearly need to be synchronised in time, so that they know exactly when the "holes" become available. That is why compressed mode patterns are precisely defined. Those compressed mode patterns define e.g. Transmission Gap Lengths (TGL).

Handovers between the two different modes, FDD and TDD, are possible.

As hinted at in the previous paragraphs, handover to/from GSM radio access networks are also possible. The aim was to have the same requirements available as in the intra-GSM case. All handovers (in dedicated mode), network-controlled cell-reselection from GPRS also applies to UTRAN as a target system. The user can expect a continuity of service⁸ between the two different systems (with the GSM limitations on e.g. the number of simultaneous connections). Dedicated messages have been introduced for the network to request handover / cell-reselection between the different systems. Thresholds indicating values to take into account for autonomous UE inter-system cell-reselection have also been introduced (with the possibility of using different thresholds within each source system, to avoid ping-pong effects).

A scheme allowing a quicker implementation and fulfilling e.g. agreements between operators of different systems (GSM and UTRAN) was also introduced for Release 99: the "equivalent PLMN" scheme. This allows an autonomous cell-reselection in (packet) idle modes for the UE, between different systems. In effect, a set of PLMN Identities is indicated by the networks, instead of one PLMN Identity. The UE can reselect between the systems, using the thresholds required for the decision, in effect as if it were roaming within the same PLMN.

2.3 Mandatory Speech Codec for Narrowband Telephony Service

Acronym: AMR-NB or AMR

⁸ This was once mentioned as a stand-alone item called "GSM/UMTS service continuity and equivalent PLMN".

References for WI " Mandatory Speech Codec for Narrowband Telephony Service "

Document	Title/Contents
WIDs	
SA4_Work_Items_History	WI Sheet
SP-99060	WID WI S4-1: Mandatory Speech Codec for Narrow band Speech Telephony Service
Impacted Specifications	
04.08	Mobile radio interface layer 3 specification
05.01	Physical layer on the radio path; General description
05.02	Multiplexing and multiple access on the radio path
05.03	Channel Coding
05.05	Radio transmission and reception
05.08	Radio subsystem link control
05.09	Link Adaptation
05.50	Background for Radio Frequency (RF) requirements
08.60	Inband control of remote transcoders and rate adaptors for Enhanced Full Rate (EFR) and full rate traffic channels
08.61	In-band control of remote transcoders and rate adaptors for half rate traffic channels
11.21	BSS Radio aspects
New Dedicated Specifications	
TS 05.09	Radio Access Network; Link Adaptation
TS 26.071	Mandatory Speech Codec speech processing functions AMR Speech Codec; General Description
TS 26.073	ANSI-C code for the Adaptive Multi Rate speech codec
TS 26.074	AMR speech codec test sequences
TS 26.090	AMR speech codec; Transcoding functions
TS 26.091	AMR speech codec; Error concealment of lost frames
TS 26.092	AMR Speech Codec; Comfort noise aspects
TS 26.093	AMR Speech Codec; Source Controlled Rate operation
TS 26.094	AMR speech codec; Voice Activity Detector (VAD)
TS 26.101	AMR Speech Codec Frame Structure
TS 26.102	AMR speech codec; Interface to Iu and Uu
TS 26.103	Speech Codec List for GSM and UMTS
TS 26.104	ANSI-C code for the floating-point Adaptive Multi Rate (AMR) speech codec
TR 26.975	Performance characterization of the Adaptive Multi-Rate (AMR) speech codec

The feature "Mandatory Speech Codec for Narrowband Telephony Service" was developed by the 3GPP SA4 group. Its scope is to define the default speech codec for UMTS (both for FDD and TDD). This definition was in fact limited to a selection of one codec among several already existing ones: the proposed codecs were GSM AMR, IS127 EVRC, ITU G.729 and MPEG-4 speech codec.

A set of subjective tests was developed to compare the performance of the proposed candidates in different conditions: with and without background noise, with channel errors (using error patterns specifically developed by ARIB for this project), in tandeming⁹ and with music-on-hold. A number of organisations performed the required subjective tests with the proposed candidate speech codecs.

The codec selection was completed by April 99 and the codec characterisation was completed at a later date, mainly in TR 26.975 but not completed until Release 6 for the PS domain.

As a result of the selection, 3GPP adopted the GSM AMR (narrowband) speech codec as the mandatory default 3G speech codec, for the following reasons:

- The GSM AMR includes multiple (eight) codec modes providing the required flexibility to offer a toll quality speech service without compromising the system capacity;
- It includes the GSM EFR (at 12,2 kbit/s) and the IS136 EFR (at 7,4 kbit/s) offering a high level of compatibility with key 2G systems;
- No other candidate codec provides better performances than the GSM EFR (highest mode of GSM AMR). The GSM EFR was found to provide the best performance with respect to

⁹ "tandeming" is the use of two codecs in the transmission path, e.g. in GSM, the voice is AMR-encoded in the source terminal, then AMR-decoded in the source BTS, then transcoded to be transported in the core network, and is again AMR-encoded in the destination BTS and finally decoded in the destination terminal.

the requirements set by ARIB for the mandatory speech codec, often exceeding the required performance level;

- At equivalent source rate, the internal codec modes of AMR always provide equivalent or better performance than the other candidate speech codecs. For example the AMR codec modes at 7,95 kbit/s (and 7,4 kbit/s) were found to be equivalent or better than the IS127 EVRC (8,55 kbit/s mode) or the G.729 (8 kbit/s);
- The AMR speech codec specifications were already approved by ETSI TC SMG. The corresponding C-code was released as part of the specifications. The completion of the 3GPP mandatory speech codec specifications in the time frame presented above would not have been achievable if the selected codec specifications and C-code was had not already been publicly available.
- Speech quality is equivalent to wireline speech codec (ADPCM - G.726) in “No Errors” conditions
- The degradation is limited under normal operational conditions (with channel errors, in tandeming)
- It offers a good trade-off between complexity and performances for low cost implementation in 3G systems.

After the selection of the speech codec, the complete operation of the codec was defined when used on top of FDD and TDD channels, including the discontinuous transmission operation and/or variable rate operation. The definition of the best channel coding (based on existing bearers versus dedicated bearer with unequal protection) was defined by WG SA4 in cooperation with WGs RAN1 and RAN2.

Finally, the operation of the mandatory speech codec was fully characterized in multiple 3G operational environments (except for PS domain, left to Rel-6).

2.4 Codec for Low Bitrate Multimedia Telephony Service

Acronym: H.324M

References for WI " Codec for Low bit rate Multimedia Telephony Service "	
Document	Title/Contents
WIDs	
SA4_Work_Items_History	WI Sheet
SP-99060	WID WI S4-2: Codec for Low bit rate Multimedia Telephony Service
Impacted Specifications	
TS 26.110	Codec for Circuit Switched Multimedia Telephony Service; General Description
TS 26.111	Codec for circuit switched multimedia telephony service; Modifications to H.324
TR 26.911	Codec(s) for circuit switched multimedia telephony service; Terminal implementor's guide
TR 26.912	QoS for Speech and Multimedia Codec; Quantitative performance evaluation of H.324 Annex C over 3G
TR 26.915	Echo Control For Speech and Multi-Media Services
New Dedicated Specifications	
	None

The scope of the feature is to specify the default codec for multimedia telephony service for UMTS. In this release, multimedia telephony service is limited to low bitrate, circuit switched connections.

The specification of a default multimedia telephony codec enables terminals capable of low-cost, high-quality, real-time, two-way multimedia communications. It also allows interoperability of different manufacturers' equipment, thus broadening the potential market for such devices.

Here again, the specification was in fact just a selection. The results on the tests were included in TR 26.912 on the quantitative evaluation of circuit switched H.324 based multimedia codecs over 3G.

ITU-T H.324/ANNEX C (Multimedia Telephone Terminals Over Error Prone Channels) was chosen as the core of the protocol. It makes efficient use of the radio resources and takes into account the error prone nature of radio based networks. Where H.324/ANNEX C falls short, other relevant standards are used as follows:

- AMR speech codec is adopted as the only mandatory speech codec for CS multimedia telephony services to offer the same level of speech quality as the basic speech service. Note that the ITU-T H.324 mandates the support of the G.723.1 speech codec, which is considered by the experts as providing a lower quality level than the higher modes of AMR.
- H.263 was adopted as the only mandatory video codec. Note that H.324 also mandates terminals to support the less advanced H.321 video codec.
- H.223 Annex B (which includes Annex A) is specified as the minimum multiplex error detection and protection level. This level was considered to provide an acceptable performance/complexity trade-off.
- Additionally, call setup and termination are not defined in H.324/ANNEX C. 3GPP described it in TS 24.008 (and not in TS 26.112, withdrawn before its completion and replaced by 24.008).

The mandatory characteristics described above do not remove any options in H.324. WG S4 believed that it was essential to complete this set of mandatory requirements with a number of "recommendations" to help in the implementation of 3G terminals in order to guarantee enough error resilience and favour efficient terminal interworking. Two of the key "recommendations" are:

- To support the optional G.723.1 speech codec
- To support the optional MPEG-4 video codec

H.323 could also be used to satisfy the above requirements for packet switched connections. However, there are additional issues, relating to H.324 (such as IP over wireless network) that need to be addressed within 3GPP that would preclude consideration of H.323; however, this Work Item also addressed those H.323 issues.

The interoperability with other or existing systems was a low priority because of the low penetration of fixed access multimedia terminals and services. A consequence of this choice is that transcoding or gateway functions will be required when interoperability with existing multimedia terminals not supporting H.324 Annex C have to be provided.

The related codec requirements were specified assuming that 3G systems will carry the multimedia data as a single data flow at the output of the H.223 multiplex, and not separate the different media flows before the H.223 multiplex to send them over separate radio access bearers. This decision was essentially guided by time constraints for the completion of the corresponding specification and the well established performance of H.324 in this configuration.

2.5 3G audio-visual terminal characteristics

Acronym: 3G-AVT

References for WI " 3G audio-visual terminal characteristics "	
Document	Title/Contents
WIDs	
SA4_Work_Items_History	WI Sheet
SP-99129	WID TSG-S4 Work Item on 3G Audio-Visual Terminal Characteristics
Impacted Specifications	
TS 26.131	Terminal acoustic characteristics for telephony; Requirements
TS 26.132	Narrow band (3,1 kHz) speech and video telephony terminal acoustic test specification
New Dedicated Specifications	
	None

The scope of the feature "3G audio-visual terminal characteristics" is to specify the acoustic and visual performance of terminals.

The provision of speech, multimedia (e.g. video telephony) and wideband audio services in 3G terminals requires the specification of certain terminal characteristics, notably acoustic and visual (display/camera) characteristics. This feature develops the acoustic and visual requirements and the test methods needed to support these requirements for 3G speech and multi-media terminals in support of the mandatory speech service, the H.324 and H.323 narrowband video telephony service and wideband speech service work items. The set of requirements and test specifications were passed to TSG T for inclusion in its terminal specification work.

The specifications TS 26.131 and TS 26.132 detail the requirements for acoustic parameters, such as SLR (Send Loudness Rating), and the test methods to assess terminal conformance and performance.

3 UMTS and GSM Features

3.1 Multimedia Messaging Service

Acronym: MMS

References for WI " Multimedia Messaging Service (MMS)"	
Document	Title/Contents
WIDs	
TP-000022	WI Sheet
Impacted Specifications	
	None.
New Dedicated Specifications	
22.140	MMS stage 1
23.140	MMS stage 2/3

After Short Message Service (SMS) and Enhanced Messaging Service (EMS) described below, the next stage of messaging evolution is MMS, which delivers an even richer messaging experience. MMS is introduced in Release 99. It allows users to send and receive messages exploiting a large array of media types e.g. text of almost unlimited length, images, audio and video clips, while also making it possible to support new content types as they become popular. MMS supports standard image formats such as GIF (Graphics Interchange Format) and JPEG (Joint Picture Expert Group), video formats such as MPEG 4 (Motion Picture Expert Group) and audio formats and MIDI (Musical Instrument Digital Interface). Multiple media elements can be combined into a composite single message. Messages can be sent either to a mobile phone or to an e-mail address.

The main new network element of the Multimedia Message Service Environment (MMSE) is the MMS Relay/Server which is responsible for storage and handling of incoming and outgoing messages and for the transfer of messages between different messaging systems. Other involved MMS elements are the MMS User Agent and MMS User databases. The functional descriptions of the involved MMS elements are provided in TS 23.140 and for implementation of the MMS User Agent – MMS Relay/Server interface a reference to the WAP Implementation of MMS is given.

Note that the Release 99 specifications only include the concept with little technical details. A detailed description of architecture and protocols is only available from Rel-4 onwards.

3.2 Location Services

Acronym: LCS

References for WI " LCS"

Document	Title/Contents
WIDs	
SP 99-327	Proposed Work Item on Location Services for UMTS
Impacted Specifications	
23.002	GSM/UMTS General Architecture
29.002	MAP (Mobile Application Part)
25.331	Radio Resource Control (RRC); protocol specification (UMTS only)
25.306	UE Radio Access Capabilities (UMTS only)
25.413	UTRAN Iu interfaces RANAP signalling (UMTS only)
25.423	UTRAN Iur interfaces RNSAP signalling (UMTS only)
New Dedicated Specifications	
22.071	LCS Stage 1 (for GSM and UMTS)
03.71	LCS Stage 2 for GSM
23.171	LCS Stage 2 for UMTS
04.71	LCS Mobile radio interface layer 3 (including LLP: LMU LCS Protocol) (GSM only)
04.31	RRLP (Radio Resource LCS Protocol) (GSM only)
08.71	BSSLAP (BSS LCS Application Leaves) (GSM only)
08.31	SMLCPP (SMLC Peer Protocol) (GSM only)
09.31	BSSAP LE (DTAP and BSSMAP extensions to support LCS) (GSM only)
25.305	Functional stage 2 specification of Location services in UTRAN (UMTS only)
23.032	Universal Geographical Area Description

Location Services is a feature providing the ability to localise a terminal (MS - Mobile Station in GSM and UE - User Equipment in UMTS). This location information is used to provide services to the end-user (e.g. to offer a local map with indication of closest restaurants, etc), for emergency services or for “internal clients”, i.e. a UMTS network entity, like an RNC to direct the beam when space diversity is used (not used at least up to Release 6).

The work on this feature was initiated by T1P1, who worked on location services only for use in emergency situation. Then their work was transferred to 3GPP who extend its scope to cover commercial aspects as well. LCS was introduced for GSM in Release 98, and was enhanced for GSM and adapted to UMTS in Release 99.

The location relies on three key functions: the measurement of the radio signals, performed by the LMU (Location Measurement Unit); the calculation of the position and the global coordination, performed by the SMLC (Serving Mobile Location Centre); and the dialogue between the network and the external LCS client, performed by the GMLC (Gateway MLC). The architectures, both for GSM and for UMTS, are shown below, extracted from TS 03.71 for the GSM (GERAN) aspects and from TS 23.171 for the UMTS (UTRAN) aspects.

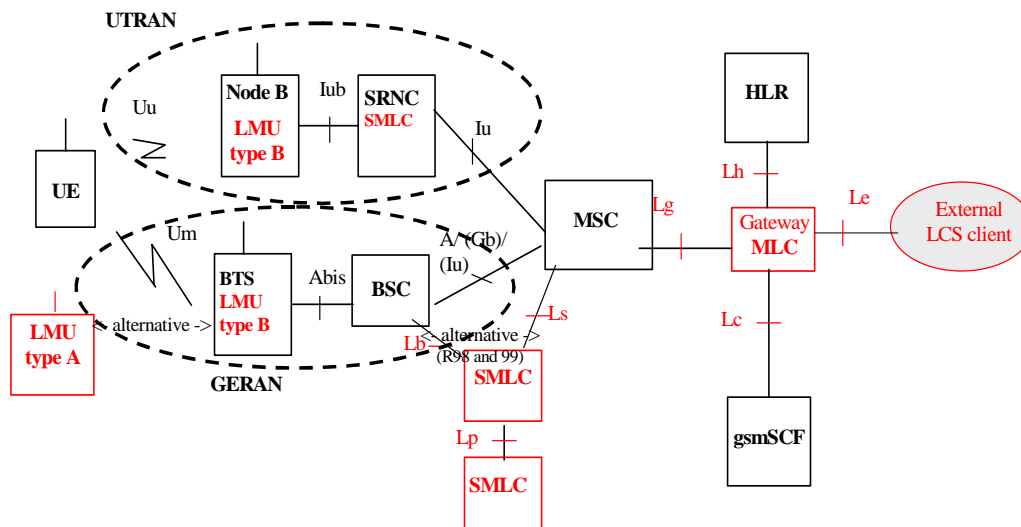

UMTS and GSM LCS architecture

Legend: Red lines and entities: interfaces and entities specific to LCS
 Black lines and entities: other interfaces and entities

The entity being tracked is the MS/UE at the far left (shown as “UE” in the figure). The External LCS client at the far right is the entity using the location information for himself (emergency services) or to provide the commercial service to the User.

The label “alternative” on the figure means that two options are possible:

- the LMU can be on the infrastructure side or can be a stand-alone entity, communicating with the infrastructure re-using the Radio interface using its own IMSI (even in the later case, the LMU remains a network element),
- the SMLC can be connected to the BSC or to the MSC.

The options reflect lack of decision at 3GPP in the face of balanced advantages: in the first case, a type A LMU (stand-alone entity) is easier to deploy but consumes radio resources, contrarily to a type B LMU. With respect to the second option, connecting an SMLC to the MSC reduces the number of connections (there are fewer MSC than BSCs) but involves the MSC for relaying a user-access centric dialogue between the BSC and the SMLC. This second option will disappear in later releases.

The flows for the External Client to get the position of the User are the following:

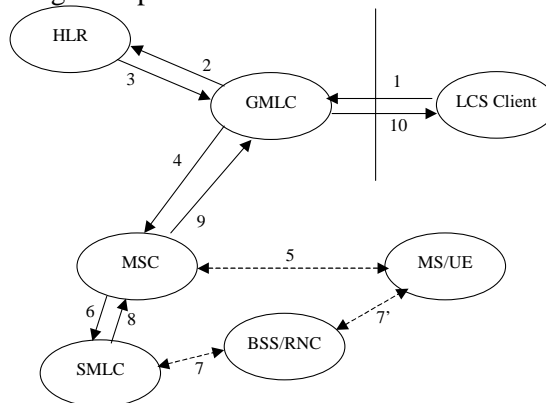

Flows for LCS

1. The LCS client requests to his allocated GMLC the location of the UE by sending the message « LCS Service Request » on the Le interface (fully defined only from Release 5 onwards: the dialogue is on a proprietary basis for previous releases).
2. The GMLC contacts the HLR to obtain the address of the current VLR/MS of the subscriber.
3. The HLR answers, after having checked that the requesting GMLC is authorised to obtain the location of the subscriber (2 and 3: MAP messages Send_Routing_Info_For_LS, TS 29.002, 1A.1.2).
4. The GMLC then contacts the MSC/VLR in the visited network to obtain the location information. The VLR checks that the subscriber authorises the transmission of his location. (4 and 9: MAP messages Provide_Subscriber_Location, TS 29.002, 1A.2.2)
5. Once these checks have been made, the terminal is, if necessary, paged and authenticated, and, potentially, encryption is activated. The MS is then supposed to be reachable if LCS client asks for it (Location_Notification_Invoke and Location_Notification_Return_Result messages, presented in stage 2 but not defined in stage 3).
6. The MSC then starts the active phase of recovery of the location of the MS, soliciting the SMLC with BSSMAP LE Perform Location request (09.31) message in GERAN. This message is sent directly from the MSC to the SMLC in the event of "NSS-based solution" or forwarded transparently by the BSC for the "BSS-based solution".
7. The radio location procedure is then triggered: several procedures are defined, which may or not involve the MS/UE. As a result of the radio location procedure, the SMLC knows the position of the MS.
8. The MS/UE position is then forwarded from the SMLC towards the LCS client. The payload of this message is the Information Element "Location Estimate" or "Geographic Location IE" (different names are used in different documents), the coding for which is given in TS 23.032.
9. The location information then reaches the requesting GMLC (in response to message 4: Provide_Subscriber_Location, TS 29.002, 1a.2.2).
10. Lastly, this information reaches its final recipient, the LCS client, by the message "LCS Service Response", which, as its homologue "LCS Request service" is mentioned in stage 2 but not in stage 3 for this Release.

The radio location procedure (step 7 in the above procedure) can be any of four types in GSM and three types in UTRAN. The GSM procedures are:

- Timing Advance (TA). This method provides a location area in the shape of a ring centered on the BTS whose identity is returned by the TA Response message. The radius of the ring is the Timing Advance multiplied by the speed of light.
- Uplink Time Of Arrival (TOA). This method consists of determining times of arrival at three LMUs (with known geographical co-ordinates) of a signal emitted by the mobile. These times determine the distance from the mobile, from which, by triangulation, the position of the mobile is deduced.
- Enhanced Observed Time Difference (E-OTD). The MS measures the times of arrival of bursts sent by three radio-visible BTSs. Two options are possible: calculation is performed either directly by the MS (MS Based E-OTD), or in the SMLC with the measurements provided by the MS (MS Assisted E-OTD).
- Assisted GPS: the coordinates of the MS are directly obtained by GPS (Global Positioning System), independently of the GSM network.

The UMTS procedures are:

- Cell ID based. This is the simplest case, where the resulting location information is simply the serving cell identity (Node B) or a geographical area corresponding to this cell (a disk centred on the BTS/Node B), plus possibly some other indications like the RTT (Round Trip Time).
- OTDOA-IPDL (Observed Time Difference Of Arrival – Idle Period DownLink), where the MS measures the difference of time of arrival of a reference signal from two Nodes B, which makes it possible to locate the MS on a hyperbola based on these two Node Bs. The use of a third Node B makes it possible to identify two other hyperbolae and the intersection of these hyperbolae locates the MS. One can thus speak about a solution inherited of the hyperbolic solution E-OTD.
- Network Assisted GPS, derived from the analogous method in GSM.

For UMTS, several other methods were suggested in stage 2, but were finally rejected: AOA (Angle Of Arrival), OTOA (Observed Time Of Arrival), OTDOA-RNBP (OTDOA Reference Node-Based Positioning) and OTDOA-PE (OTDOA Positioning Elements).

In GSM, E-OTD and A-GPS demand an action by the MS/UE, as do OTDOA-IPDL and A-GPS in UMTS. These methods are more accurate than the other ones, but they need to have LCS-capable MS/UE, i.e. they cannot work without enhancements to the MS/UE.

Finally, not less than 5 new protocols are introduced for GSM LCS:

- RRLP (Radio Resource LCS Protocol), defined in 04.31, for the dialogue SMLC to target MS
- LLP (LMU LCS Protocol), defined in 04.71, for SMLC to LMU dialogues
- BSSLAP (BSS LCS Application Leaves), defined in 08.71, for SMLC to BSC dialogues
- SMLCPP (SMLC Peer Protocol), defined in 08.31, for SMLC to SMLC dialogues
- BSSAP LE defined in 09.31, for the needed DTAP and BSSMAP extensions to support LCS.

In UTRAN, the Stage 2 is defined in a dedicated specification: TS 25.305 entitled "Functional stage 2 specification of Location services in UTRAN". The Stage 3 is much more integrated into the existing protocols than in GSM. It is defined through "General" UTRAN Stage 3, namely mainly in 25.331 ("Radio Resource Control (RRC); protocol specification"), but also in the following specifications:

- TS 25.306: "UE Radio Access Capabilities".
- TS 25.413: " UTRAN Iu interfaces RANAP signalling".
- TS 25.423: " UTRAN Iur interfaces RNSAP signalling".

All these options on architecture and on radio methods did not facilitate at all a rapid and inexpensive introduction of standardised LCS into the market.

3.3 CAMEL phase 3

Acronym: CAMEL3

3.3.1 Global view

References for WI "CAMEL Phase 3"

Document	Title/Contents
WIDs	
Not found	WI description
SP-99368	LS regarding the scope of CAMEL Phase 3
Impacted Specifications	
TS 22.078	CAMEL - Stage 1
TS 23.078	CAMEL – Stage 2
TS 29.078	CAMEL – Stage 3
New dedicated Specifications	
	None

CAMEL (Customized Applications for Mobile network Enhanced Logic) is a network feature that provides the mechanisms to support services of operators which are not covered by standardised services, even when roaming outside the HPLMN.

The third phase of CAMEL enhances phase 2 by adding the following capabilities:

- Support of facilities to avoid overload: The purpose of this functionality is to control SCP (Service Control Point) overload situations within the HPLMN. It is possible for the CSE (CAMEL Service Entity) to suppress either all or some CAMEL interrogations from a VPLMN / IPLMN, when the VPLMN / IPLMN is the subscriber's HPLMN. If there is a bilateral agreement the operators may also apply congestion control between different networks. If congestion control prevents contact with the CSE, the V/IPLMN proceeds in accordance with Default Call Handling. Congestion Control is applicable to CAMEL control of a circuit switched call. It is not applicable to CAMEL control of a GPRS session and PDP context, or to CAMEL control of short message delivery.
- Capabilities to support Dialed Services: The purpose of these capabilities is to support HPLMN specific service numbers (Subscribed dialed services (D-CSI)) and VPLMN specific service numbers (Serving Network Dialed services (N-CSI))
- Capabilities to handle mobility events, such as (Not-)reachability and roaming: The SCP may request HLR to provide subscriber status and/or location information at any time.

- Control of GPRS sessions and PDP contexts: This functionality enables interworking with GPRS and is useful for GPRS pre-paid interworking (not content based).
- Control of mobile originating SMS through both circuit switched and packet switched serving network entities (not content based): This functionality enhances pre-paid service and VPN. There is no control of MT SMS in CAMEL phase 3.
- Interworking with SoLSA (Support of Localised Service Area). Support for this interworking is optional.
- The CSE can be informed about the invocation of the GSM supplementary service CCBS: It is possible to mark for a subscriber that a notification is to be sent to the CSE when CCBS supplementary service is invoked (in addition to notification of supplementary services available in CAMEL phase 2).

3.3.2 Multiple Subscriber Profile (MSP) based on CAMEL phase 3

Impacted Specification: TS 22.097 on Advanced Addressing.

Multiple Subscriber Profile is an optional service enabling mobile subscribers to have several profiles associated with a single IMSI, with each profile being a subscription option. Each profile may be used for mobile originated and mobile terminated calls.

Up to four different profiles can be provisioned for a subscriber using the MSP feature. This allows the subscriber to separate her telecommunication service needs into different identities (e.g. business and home). Separate charging for each profile is possible. To this aim, a supporting visited network shall indicate on the billing record the profile used.

For Release 99, the interaction with Multicall was adapted.

3.4 Short Message Service enhancements

Acronym: SMS enhancements

References for WI " Short Message Service (SMS) enhancements"

Document	Title/Contents
WIDs	
TP-000022	WI Sheet
Impacted Specifications	
TS 23.038	Alphabet and language specific information
TR 23.039	Interface protocols for the connection of SMSCs to SMEs
TS 23.040	Technical realization of SMS Point-to-Point
TS 23.042	Compression algorithm for text messaging services
New dedicated Specifications	
	None

This work items includes SMS for 3GPP terminals which is fully compatible with the GSM SMS service. Additional enhancements and improvements have been introduced e.g. Enhanced Messaging Service (EMS) allowing small pictures, sounds, animations to be transferred via SMS.

EMS (Enhanced Messaging Service) Rel-99 includes:

- Text formatting: Alignment, Font size, Style
- Basic pictures: small (16*16 pixels), large (32*32 pixels) or pictures of variable size, plain black and white
- Animations: Predefined, User Defined, 8*8 pixels and 16*16 pixels
- Sound: 10 different sounds Predefined, User Defined according to the iMelody format

3.5 Mobile Station Execution Environment

Acronym: MExE

References for WI " Mobile Station Execution Environment (MExE)"

Document	Title/Contents
WIDs	
WI	Roll-over WI from R98 (02.57)
TP-000022	WI Sheet
Impacted Specifications	
TS 22.057	MExE Service requirements, Stage 1
TS 23.057	MExE Functional description; Stage 2
TS 22.101	Service aspects; Service principles
New dedicated Specifications	
	None

MExE is a feature introduced in GSM Release 98, enhanced in GSM Release 99 to cover the following additional enhancements: SIM MExE certificate management, security clarifications and QoS aspects. This work item includes MExE for 3GPP terminals which is fully compatible with GSM MExE Release 99, providing a flexible API for the terminal for third party applications.

MExE provides a standardised execution environment in an MS, and an ability to negotiate its supported capabilities with a MExE service provider, allowing applications to be developed independently of any MS platform. The MS can then be targeted at a range of implementations for MExE from small devices with low bandwidth, limited displays, low processor speeds, limited memory, MMI etc., to sophisticated with a complete MExE execution environment.

A standardised means of negotiating the MSs' and network's capabilities is supported. This negotiation permits the mutual exchange of capabilities between the MS and the MExE server, and possibly includes the service profile of the user and capabilities of the network.

A network can be a transport bearer for the negotiation, interaction and transferring of applications, applets and content with the MS. It does not have to be the provider of the MExE services with which the MS's execution environment is interacting with. The network may also be the intermediary between two MSs which are engaged in a MExE service with each other, with the network effectively supplying the "pipe" and not playing a MExE role in the connection.

Network nodes, nodes external to the network, or even MSs are the entities which can interact with the MS's execution environment.

Central elements of the MExE specification are the classmark concept, content negotiation and the security architecture.

MExE categorises devices by giving them different MExE classmarks. In R99, two MExE classmarks are defined:

- MExE classmark 1 - based on Wireless Application Protocol (WAP) - requires limited input and output facilities (e.g. as simple as a 3 lines by 15 characters display and a numeric keypad) on the client side, and is designed to provide quick and cheap information access even over narrow and slow data connections.
- MExE classmark 2 - based on Personal-Java - provides and utilises a run-time system requiring more processing, storage, display and network resources, but supports more powerful applications and more flexible MMIs. MExE Classmark 2 also includes support for MExE classmark 1 applications (via the WML browser.)

Content negotiation allows for flexible choice of formats available from a server or adaptation of a service to the actual classmark of a specific client device. Bi-directional capability negotiation between the MExE Service Environment and MExE device (including MExE classmark), supports the transfer of capabilities between the client and the server.

In order to manage the MExE and prevent attack from unfriendly sources or transferred applications unintentionally damaging the MExE device a security architecture is specified. The basis of MExE security is:

- a framework of permissions which defines the permissions transferred MExE executables have within the MExE MS;

- the secure storage of these permissions and permission types);
- conditions within the execution environment that ensure that MExE executables can only perform actions for which they have permission.

The MExE permissions framework is as follows (there is no implied hierarchy):

- MExE Security Operator Domain (MExE executables authorised by the HPLMN operator);
- MExE Security Manufacturer Domain (MExE executables authorised by the terminal manufacturer);
- MExE Security Third Party Domain (trusted MExE executables authorised by trusted third parties);
- Support for the three domains is mandatory;

Untrusted MExE executables are not in a specific domain, and have very reduced privileges.

3.6 Multicall

Acronym: Multicall

References for WI "Multicall"

Document	Title/Contents
WIDs	
NP-99549	Multicall as R99 Work Item
NP-000084	Release 1999 Submission form
NP-000348	Merged WG Status Report For WI R99 Multicall
Impacted Specifications	
TS 24.008	Mobile radio interface layer 3 specification; Core Network Protocols; Stage 3
TS 23.009	Handover procedures
TS 23.108	Mobile radio interface layer 3 specification, Core Network Protocols - Stage 2
TS 24.080	Mobile radio interface layer 3 supplementary services specification; Formats and coding
New Dedicated Specifications	
TS 22.135	Multicall; Service description; Stage 1
TS 23.135	Multicall supplementary service; Stage 2
TS 24.135	Multicall Supplementary Service - Stage 3

Multicall is a feature which allows several simultaneous CS calls with dedicated bearers of independent traffic and performance characteristics, e.g. it allows several CS data bearers to be bound at application level resulting in higher than 64 kbit/s data rates, or it also allows simultaneous speech and data calls. Multicall was defined as a supplementary service in Release 99 with limitation of only one CS bearer to be used for speech at any one times. A speech call is one of TS11 (Telephony), TS12 (Emergency Calls), and TS61 (Alternate speech/fax).

If the bearer capability information is not available (e.g. because the call is originated/transited by a PSTN), the basic service cannot be deduced and the network shall, for Multicall purposes, handle the call as telephony. A held call shall be regarded as using the bearer employed when the call was active. With Multicall, it is possible to release each active CS call independently of any other CS call.

The maximum number of simultaneous CS bearers available to the subscriber is from 2 to 7, defined as part of the subscription by "Nbr_SB".

All of the radio signalling specific to Multicall is at the served mobile subscriber side, i.e. all other mobiles involved in the call (and non-mobiles too) see only "basic" call control and radio signalling, with no special messages or information elements pertaining to the Multicall service.

The mobile subscriber supporting Multicall shall include the stream identifier (SI) Information Element (IE). The purpose of the SI IE is to associate a particular call with a Radio Access Bearer (RAB), and to identify whether a new traffic channel is requested for the call. TS 24.008 defines the rules on allocating SIs. MS capability (number of bearers and number of speech bearers) is included in Call Control IE. And since the MS shall be aware of the network capabilities, the network indicates its Multicall capability to the MS by using CC message. When the MS is located in a network not supporting Multicall, it shall not request multiple bearers.

At inter-MSC handover, in case just one RAB can be maintained after the handover (e.g. at handover from UMTS to GSM), MSC-B indicates to MSC-A which RAB has been selected so that the corresponding call is the only one maintained.

3.7 Open Service Architecture

Acronym: OSA

References for WI "OSA"	
Document	Title/Contents
WIDs	
S1-99133	Historical information can be found in the meeting reports of SA#5 to 8 as well as in SP-99416, SP-000095 and SP-000155.
Impacted Specifications	
None	None
New Dedicated Specifications	
TS 22.121	Virtual Home Environment (VHE) Service aspects Stage 1
TS 23.127	Virtual Home Environment (VHE) / Open Service Architecture (OSA); Stage 2
TS 29.198	Open Service Architecture (OSI) Application Programming Interface (API) - Part 1
TS 29.998	Open Services Architecture API part 2

These specifications were produced jointly by Parlay, ETSI SPAN (now TISPAN) and 3GPP WGs SA1 (Stage 1), SA2 (Stage 2) and CN5 (Stage 3), so that there is a single set of standard OSA APIs for the whole development community.

Open Service Architecture (which became in later Releases “Open Service Access”) allows service development by operators and third parties: it enables service application developers to make use of network functionality through open, standardised, secure, extensible and scalable interfaces. Applications see the network functionality offered to them as a set of Service Capability Features (SCFs) in the OSA APIs. These SCFs provide access to the network capabilities on which the application developers can rely when designing their applications. The OSA APIs are independent of where or which network capabilities are implemented in the network, and of vendor-specific solutions and programming languages.

Two different types of SCFs can be distinguished:

- Framework SCF: they provide commonly used utilities, necessary for the non-framework service capability features to be accessible, secure, resilient and manageable. The Framework SCFs are:
 - Authentication
 - Authorisation
 - Registration
 - Discovery
 - Notification
- Non-Framework SCFs: they enable the applications to make use of the functionality of the underlying network capabilities (e.g. User Location service capability features). The Non-Framework SCFs are:
 - Session Control
 - Security/Privacy
 - User Location
 - User Status
 - Terminal Capabilities
 - Information Transfer
 - User Profile Management
 - Charging

The feature also defines the OSA interface for the communication between Applications and SCFs.

3.8 Super Charger

Acronym: Super Charger

References for WI "Super Charger"

Document	Title/Contents
WIDs	
Not found	WI Sheet
Impacted Specifications	
TS 21.905	3G Vocabulary
TR 23.912	Technical Report on Super-Charger
TS 23.007	Restoration Procedures
TS 23.008	Organisation of Subscriber Data capabilities
TS 23.012	Location Management Procedures
TS 23.016	Subscriber Data Management: Stage 2
TS 23.040	Technical Realisation of the Short Message Service (SMS); Point-To-Point (PP)
TS 23.060	General Packet Radio Service; Stage 2
TS 29.002	Core Network Protocols; Stage 3
New Dedicated Specifications	
None	None

The Super-Charger constitutes a change to the subscriber data management to reduce mobility management costs associated with inter-VLR and SGSN location updates, at the cost of increased memory in the VLR and minor protocol modifications.

Without Super-Charger, the subscriber data at the old MSC/VLR is deleted when the subscriber moves to a location area served by a different MSC/VLR.

With Super-Charger, the subscriber data is maintained in the old MSC/VLR, which removes the need to use the cancel location procedure, as shown in the figure "Morning Commute in a Super-Charged Network". The HLR performs the normal "insert subscriber data" procedure at the new MSC/VLR. The subscriber data at the old MSC/VLR is not maintained, so no additional signalling is required.

The network benefits from Super-Charger when the subscriber roams to a previously visited MSC/VLR where the user's subscription data is already present. In this case, provided the subscription data is still valid, there is no need to perform the "insert subscriber data" procedure, as shown in the following figure. Consequently, it reduces mobility management cost by reducing the volume of location update signalling.

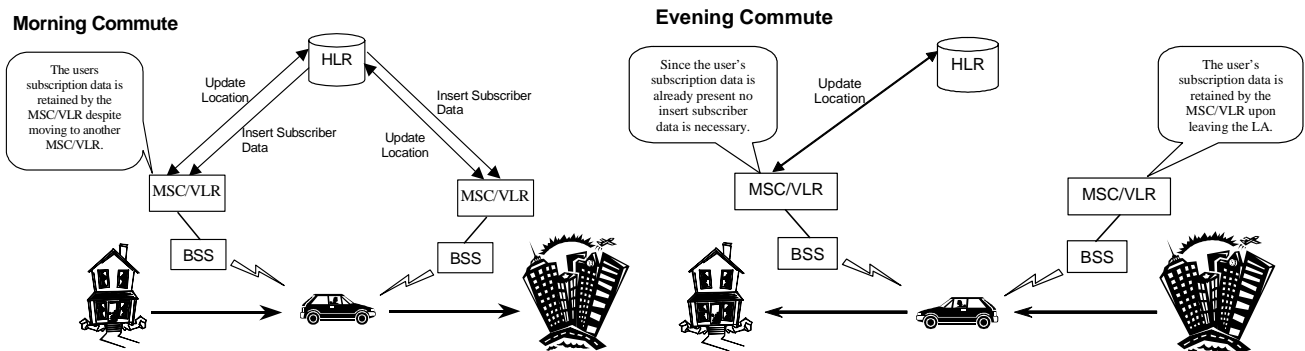

Morning and Evening Commutes in a Network using Super-Charger

Super-Charger is of most benefit in metropolitan areas where the density of MSC/VLRs is high to cope with the large number of subscriber, and subscribers regularly commute between location areas served by different MSC/VLRs. Assuming the subscriber data has not been deleted or changed since the subscriber was last attached in the location area, then the MSC/VLR has the option to use the subscriber data previously downloaded. However, the HLR will ultimately control data retention and updates in the MSC/VLR.

In a "Super-Charged" network, subscription data is retained by the previous network entity when the subscriber roams to a new network entity.

When a subscriber performs location updating in a Super-Charged network, the HLR shall cancel the subscription information at the previous network entity only if it does not support the Super-Charger functionality. If the network entity to which the subscriber has roamed has retained subscription data from a previous visit, then the HLR shall only send subscription data to the network entity if the retained subscription data is not consistent with the data stored by the HLR. If the HLR does not send subscription data to the serving network entity, it shall treat the retained subscription data as valid.

To know whether the data maintained in the VLR is still valid when the subscriber re-enters the Location Area, a new optional parameter called “ageOfSubscriberData” is added to the “MAP Update Location” message. This parameter indicates whether the VLR supports the Super-Charger, and provides the date/time at which the subscription data was last modified in the HLR. This new optional parameter is also added to the “Insert Subscriber Data” message to communicate the date/time at which the subscription data was last modified. Upon receipt of the “ageOfSubscriberData” parameter, the HLR shall compare the received date/time against the date/time stored against the subscription data in the HLR and the insert subscriber data procedures is triggered only if the VLR’s “ageOfSubscriberData” is older than the HLR’s one.

The Super-Charger concept is equally applicable to packet services. In this case, in the previous explanations, “VLR” has to be replaced by “SGSN” and “MAP Update Location” has to be replaced “MAP Update GPRS Location”.

3.9 Follow Me

Acronym: FM

References for WI "Follow Me"

Document	Title/Contents
WIDs	
Not found	WI Sheet
Impacted Specifications	
TS 21.905	3G Vocabulary
TS 22.004	General on Supplementary Services
TS 22.030	Man-Machine Interface (MMI) of the Mobile Station
TS 22.082	Call Forwarding (CF) supplementary services - Stage 1
TS 22.090	Unstructured Supplementary Services Data (USSD)- Stage 1
TS 23.090	USSD - Stage 2
TS 24.090	USSD - Stage 3
TS 22.094	Follow Me (FM) feature - Stage 1
TS 23.011	Technical realisation of Supplementary Services - General Aspects
TS 23.015	Technical realisation of Operator Determined Barring (ODB)
TS 23.082	Call Forwarding (CF) supplementary services - Stage 2
TS 29.002	Mobile Application Part (MAP)
New Dedicated Specifications	
	None

“Follow Me” (FM) enables an initiating mobile subscriber A to have control over the Follow Me data of a subscriber B such that subsequent calls destined to Subscriber B are forwarded to initiating subscriber A. An initiating subscriber might also be allowed to erase the Follow Me data of a remote subscriber who has been registered to a different initiating subscriber for the Follow Me application (this functionality is called “forced erasure”).

Follow Me is a PLMN specific feature and the control operations of FM are based on USSD. All messages between the MS and the mobile network and the ones internal to the mobile network are USSD messages.

The functionality of forwarding calls for subscriber B to initiating subscriber A (after successful registration of FM) is the same as the functionality of the Call Forwarding Unconditional (CFU) Supplementary Service applied to all telecommunication services of subscriber B for which CFU is applicable. It can also be achieved by making use of an equivalent operator specific service (e.g. via CAMEL).

The functionality of the control of Follow Me (registration, erasure, forced erasure and interrogation) is split between the HLR of the initiating subscriber A (HLRa) and the Follow me Function Node (FFN) of the subscriber B (FFNb).

3.10 Synchronisation and Object exchange

No acronym

References for WI " Synchronisation & Object exchange "	
Document	Title/Contents
WIDs	
TP-000022	WI Sheet
Impacted Specifications	
	None
New Dedicated Specifications	
TR 27.903	Discussion of synchronisation standards
TS 27.103	Wide Area Network Synchronisation

As part of this work item, the concept of Wide Area Synchronisation for 3GPP has been developed to allow data stored in the ME/USIM to be synchronised with the outside world.

TR 27.903 provides information on existing synchronisation protocols. It summarises proprietary and standard protocols relevant to current and future mobile communication devices. The document covers only synchronisation between end-user devices, desktop applications, and server-based information services. It does not refer to replication or synchronisation between enterprise databases.

After the analysis done within the above TR, TS 27.103 was created. This specification provides a definition of a Wide Area Synchronisation protocols. The synchronization protocol was based upon IrMC level 4. The document covers Wide Area Network Synchronisation between current and future mobile communication end-user devices, desktop applications and server-based information servers. It was designed as a living document and, as such, it will evaluate new technologies (e.g. XML) for inclusion as they become readily available. (Please note that from Rel-4 onwards the IrMC was removed from 27.103 and replaced by SyncML.)

3.11 Terminal interfaces

3.11.1 AT commands for 3GPP

No acronym

References for WI " Terminal interfaces (AT commands for 3GPP)"	
Document	Title/Contents
WIDs	
TP-000022	WI Sheet
Impacted Specifications	
TS 27.005	Use of Data Terminal Equipment - Data Circuit terminating Equipment (DTE - DCE) interface for Short Message Service (SMS) and Cell Broadcast Service (CBS)
TS 27.007	AT command set for 3G User Equipment (UE)
New Dedicated Specifications	
	None

This work item is about AT¹⁰ commands for control of 3GPP Mobile Equipments (MEs) via an external Terminal Equipment (TE), fully compatible with GSM AT commands. Several new AT commands have been added in Release 99 e.g. to control ASCII¹¹ services.

¹⁰ AT: ATtention; this two character abbreviation is always used to start a command line to be sent from TE to TA. TE is the Terminal Equipment, e.g. a computer (equal to DTE; Data Terminal Equipment), TA is Terminal Adaptor, e.g. a GSM data card (equal to DCE; Data Circuit terminating Equipment)

¹¹ ASCII: Advanced Speech Call Items, including Voice Group Call Service (VGCS), Voice Broadcast Service (VBS) and Enhanced Multi-Level Precedence and Pre-emption Service (eMLPP)

TS 27.005 defines three interface protocols for control of SMS functions within a GSM mobile telephone from a remote terminal via an asynchronous interface. This specification considers the mobile termination to be a single entity, i.e. not considering the split of functionality between the mobile equipment and SIM described in the series 31.xxx of TS.

TS 27.007 specifies a profile of AT commands and recommends that this profile be used for controlling ME functions and GSM network services from a TE through Terminal Adaptor (TA). The command prefix +C is reserved for Digital Cellular in ITU-T Recommendation V.25ter. This TS has also the syntax details used to construct these extended GSM commands. Commands from ITU-T Recommendation V.25ter and existing digital cellular standards (TIA IS-99 and TIA IS-135) are used whenever applicable. Some of the new commands are defined such way that they can be easily applied to ME of networks other than GSM.

3.11.2 Physical interfaces

No acronym

References for WI " Terminal interfaces (physical interfaces)"	
Document	Title/Contents
WIDs	
TP-000022	WI Sheet
Impacted Specifications	
	None
New Dedicated Specifications	
TR 27.901	Report on Terminal Interfaces - An Overview

Under this work item several options for physical terminal interfaces have been evaluated. Finally, 3GPP concluded that 3GPP should not produce any technical specification for terminal interfaces other than the radio interface and the USIM interface. The SDOs could develop their own optional physical connector specification based on their market requirements.

3.11.3 Multiplexer

Acronym: MUX MS-TE

References for WI " Terminal interfaces (multiplexer)"	
Document	Title/Contents
WIDs	
TP-000022	WI Sheet
Impacted Specifications	
TS 27.010	Terminal Equipment to Mobile Station (TE-MS) multiplexer protocol
New Dedicated Specifications	
	None

This work item is about a Multiplexing protocol to allow a number of simultaneous sessions over the terminal interface. TS 27.010 defines a multiplexing protocol between a mobile station and a terminal. The multiplexing protocol can be used to send any data, for instance voice, SMS, USSD, fax etc. It describes the protocol, but not the commands or data transported with it.

3.12 Bearer Services

3.12.1 Circuit Switched Bearer Services

Acronym: CS Data Bearers

References for WI "Description for Circuit Switched Bearers in UMTS "

Document	Title/Contents
WIDs	
N3-99151 (contained in NP-99285)	CN3 Work Item on the "Description for Circuit Switched Bearers in UMTS"
Impacted Specifications	
TS 27.001	General on Terminal Adaptation Functions (TAF) for Mobile Stations (MS)
TS 22.002	Circuit Bearer Services (BS) supported by a Public Land Mobile Network (PLMN)
TS 29.007	General requirements on interworking between the Public Land Mobile Network (PLMN) and the Integrated Services Digital Network (ISDN) or Public Switched Telephone Network (PSTN)
New Dedicated Specifications	
TS 23.910	Circuit Switched Data Bearer Services

Circuit switched data services and "real time" data services are provided for interworking with the PSTN/ISDN so that the user is unaware of the access network used (UMTS and GSM access network or handover between access networks). Both transparent (constant delay) and non-transparent (zero error with flow control) services are supported. These data services are designed to operate with minimum loss of data on handover between the GSM access network and the UTRAN.

The CS Bearers are applicable for the support of real-time applications, e.g. Fax and Video and also the GSM General Bearer Services (GBS) and interworking scenarios as specified in TS 22.002 (R99).

Both Asynchronous and Synchronous access modes are supported (if applicable) for:

- 3.1kHz Audio modems up to V.90 (0.3kbit/s-56kbit/s)
- V.110 UDI (0.3kbit/s-56kbit/s)
- X.31 flag stuffing UDI (2.4 kbit/s-56kbit/s)
- V.120 (1.2kbit/s-56kbit/s)
- Bit Transparent Mode (56kbit/s and 64kbit/s)
- PIAFS (29.2kbit/s and 58.4kbit/s).

3.12.2 Frame Tunnelling Mode

Acronym: FTM

References for WI "Frame Tunnelling Mode (FTM) in GSM and UMTS"

Document	Title/Contents
WIDs	
N3-99181 (contained in NP-99285)	CN3 Work Item on "Frame Tunnelling Mode (FTM) in GSM and UMTS"
Impacted Specifications	
TS 27.001	General on Terminal Adaptation Functions (TAF) for Mobile Stations (MS)
TS 29.007	General requirements on interworking between the Public Land Mobile Network (PLMN) and the Integrated Services Digital Network (ISDN) or Public Switched Telephone Network (PSTN)
TS 27.007	AT command set for 3G User Equipment (UE)
TS 22.002	Circuit Bearer Services (BS) supported by a Public Land Mobile Network (PLMN)
New Dedicated Specifications	
	None

Frame Tunnelling Mode (FTM) is a generic term for HDLC (High-level Data Link Control) and HDLC-related transmission protocols. FTM is a type of the asynchronous non-transparent CS bearer service (as described in TS 22.002).

The Work Item FTM provides a conversion of the asynchronous non-transparent data stream towards the mobile side and the synchronous data stream using X.31 flag stuffing on the fixed network side. This service can be used by asynchronous terminals to access ISPs providing synchronous access via ISDN. It applies both to GSM and UMTS.

3.12.3 Access to ISPs and Intranets – Wireless/Remote access to LANs

Acronym: Interworking with PDN (DHCP)

References for WI "Access to ISPs and Intranets – Wireless/Remote access to LANs"

Document	Title/Contents
WIDs	
N3-99069	CN3 Work Item on " Access to ISPs and Intranets – Wireless/Remote access to LANs "
Impacted Specifications	
TS 29.061	Interworking between the Public Land Mobile Network (PLMN) supporting packet based services and Packet Data Networks (PDN)
New Dedicated Specifications	
	None

This Work Item introduces the access to an Intranet or Internet Service Provider (ISP) by running DHCP between the TE and a server in the Intranet/ISP domain. The corresponding interworking with the PDN is described in a new clause of TS 29.061.

At PDP context activation, the MS requests an APN offering the DHCP service. The IP address of the PDP context is provisionally set to 0.0.0.0 as no IP address is allocated at this moment.

The TE runs a DHCP client, after the PDP context has been successfully activated, to retrieve the IP address and other configuration parameters from a DHCP server located in the Intranet/ISP domain. The PDP context is then updated through the GGSN-initiated modification procedure to reflect the newly allocated IP address.

A Packet Domain-specific DHCP Relay Agent is needed in the GGSN to allow for the correct routing of broadcast DHCP messages.

3.12.4 PHS Internet Access Forum Specification

Acronym: PIAFS

References for WI "PIAFS"

Document	Title/Contents
WIDs	
N3-991491 (contained in NP-99285)	Work Item "Support of PIAFS in UMTS"
Impacted Specifications	
TS 27.001	General on Terminal Adaptation Functions (TAF) for Mobile Stations (MS)
TS 29.007	General requirements on interworking between the Public Land Mobile Network (PLMN) and the Integrated Services Digital Network (ISDN) or Public Switched Telephone Network (PSTN)
TS 27.007	AT command set for 3G User Equipment (UE)
TS 22.002	Circuit Bearer Services (BS) supported by a Public Land Mobile Network (PLMN)
New Dedicated Specifications	
	None

The PHS Internet Access Forum Specification (PIAFS) service is one type of CS bearer data service as described in TS 22.002. It refers to an asynchronous circuit switched transmission protocol over ISDN

64 kbit/s unrestricted digital line. It has the particularity to be the bearer service¹² provided by the Personal Handy Phone System (PHS) in Japan.

The fact that UMTS offers this bearer service facilitates the interworking between PHS-MS and UMTS-UE, as well as the interworking between UMTS-UE and existing PIAFS TA (Terminal Adapter).

PIAFS was originally standardised by the PHS Internet Access Forum in Japan. More information can be found at: <http://www.infopro.or.jp/piaf/>.

3.13 UICC and USIM related features

3.13.1 UICC / Terminal interface; Physical and logical characteristics

Acronym: UICC

References for WI " UICC / Terminal interface; Physical and logical characteristics "

Document	Title/Contents
WIDs	
TP-99084	WI Sheet
Impacted Specifications	
	None
New Dedicated Specifications	
TS 31.101	UICC-Terminal Interface; Physical and Logical Characteristics

For 3G, the GSM specification GSM 11.11 has been divided into two parts. The 3G version of GSM 11.11 consists of a "platform" standard comprised of the basic physical, electrical and logical specification (TS 31.101) and an application specification (TS 31.102).

This work item covers the definition of a generic Terminal/Integrated Circuit Card (ICC) interface. This generic platform is independent of the 3G USIM application and can thus be the platform for any IC card application. The aim is to ensure interoperability between an ICC and a terminal independently of the respective manufacturer, card issuer or operator. Any aspects related to the administrative management phase of the ICC are not defined under this work item. Any internal technical realisation of either the ICC or the terminal is only specified where these are reflected over the interface. Application specific details for applications residing on an ICC are specified in the respective application specific documents (e.g. TS 31.102 for the USIM application).

The following aspects are specified:

- the requirements for the physical characteristics of the UICC;
- the electrical interface between the UICC and the Terminal;
- the initial communication establishment and the transport protocols;
- the model which serves as a basis for the logical structure of the UICC;
- the communication commands and the procedures;
- the application independent files and protocols.

Furthermore, general security aspects of IC cards such as file access conditions are specified. Specific USIM security aspects are dealt with in the " Characteristics of the USIM application " work item.

The UICC is capable of being used as the basis for a multi-application card: several USIMs and/or other applications can co-exist on the card. A new security architecture allows flexible and user-friendly (i.e. the ability to group PINs together) handling on PINs. For a more efficient data transfer between the terminal and the IC card, the support for the ISO/IEC T=1 block transmission protocol was added.

¹² Bearer services are sometimes called "data communication system" in the PIAFS-related documents.

Note that after the creation of the ETSI Project Smart Card Platform (SCP), 3GPP TSG-T #9 (October 2000) decided to replace the technical content of TS 31.101 R99 by a reference to ETSI TS 102 221 "Smart Cards; UICC-Terminal interface; Physical and logical characteristics (Release 1999)". Since then, ETSI EP SCP is responsible for the generic Terminal/Integrated Circuit Card (ICC) interface.

3.13.2 Characteristics of the USIM application

Acronym: USIM

References for WI " Characteristics of the USIM application "	
Document	Title/Contents
WIDs	
TP-99084	WI Sheet
Impacted Specifications	
	None
New Dedicated Specifications	
TS 31.102	Characteristics of the USIM Application

For 3G, the GSM specification GSM 11.11 has been divided into two parts. The 3G version of GSM 11.11 consists of a "platform" standard comprised of the basic physical, electrical and logical specification (TS 31.101) and an application specification (TS 31.102).

This work item covers the definition of the Universal Subscriber Identity Module (USIM) application for 3G telecom network operation. This application resides on the UICC, an IC card specified in TS 31.101 (see previous section).

The following aspects are specified:

- specific command parameters;
- file structures;
- contents of EFs (Elementary Files);
- security functions;
- application protocol to be used on the interface between UICC (USIM) and ME.

This is to ensure interoperability between a USIM and an ME independently of the respective manufacturer, card issuer or operator.

The work item does not cover any aspects related to the administrative management phase of the USIM. Any internal technical realisation of either the USIM or the ME is only specified where these are reflected over the interface. Also not covered is the definition of any of the security algorithms which may be used.

For the phone book, a new concept to handle abbreviated dialling numbers, email address and other personal data was developed (backwards compatibility issues have been addressed). New fields were specified to allow easier synchronisation with PCs or other devices. The grouping of phone numbers was standardised.

New fields are specified to allow storage of incoming and outgoing call information.

The concept of Fixed dialling Numbers (FDN) and Barred Dialling Numbers (BDN) is far less complex than in GSM. The FDN can also now be applied to particular APNs for GPRS.

Enhanced security feature were implemented e.g. new authentication (as specified by SA 3).

3.13.3 UICC Application Identifiers

Acronym: AID

References for WI " UICC Application Identifiers "

Document	Title/Contents
WIDs	
TP-99184	WI Sheet
Impacted Specifications	
	None
New Dedicated Specifications	
TS 31.110	Numbering system for telecommunication IC card applications

This work item creates a specification for the definition and administration of Application Identifiers (AID) for the UICC. The numbering system for AIDs for 3G telecommunication Integrated Circuits (IC) card applications has been defined. The numbering system provides a means for an application and related services offered by a provider to identify if a given card contains the elements required by its application and related services. An AID is used to address an application in the card. It consists of a Registered application provider Identifier (RID) and a Proprietary application Identifier eXtension (PIX). The Specification describes the coding of the PIX. The coding of the PIX as well as the registration procedure is described in accordance with ISO/IEC 7816-5.

3.13.4 USIM Application Toolkit

Acronym: USAT

References for WI " USIM Application Toolkit (USAT)"

Document	Title/Contents
WIDs	
TP-99184	WI Sheet
New Dedicated Specifications	
TS 31.111	USIM Application Toolkit (USAT)

This work item covers the definition of the interface between the Universal ICC (UICC) and the Mobile Equipment (ME), and mandatory ME procedures, specifically for "USIM Application Toolkit". The work was originally based on GSM 11.14 (SIM Application Toolkit). Commands and procedures are defined in both the USIM and 3G Terminal for using the USIM Application Toolkit. The requirements are derived from the service and security requirements defined in 3G TS 22.100 and 22.101.

USAT is a set of commands and procedures for use during the network operation phase of 3G, in addition to those defined in TS 31.101. The USAT provides mechanisms which allow applications, existing in the UICC, to interact and operate with any ME which supports the specific mechanism(s) required by the application.

Specifying the interface is to ensure interoperability between a UICC and an ME independently of the respective manufacturers and operators.

The following aspects are defined:

- the commands;
- the application protocol;
- the mandatory requirements on the UICC and ME for each procedure.

Examples of defined functions are (many more exist):

- displaying text from the UICC to the ME
- sending a short message
- setting up a voice or data call to a number held by the UICC
- initiating a dialogue with the user
- Data download to UICC
- Menu selection

Any aspects related to the administrative management phase are not specified. Any internal technical realization of either the UICC or the ME are only specified where these reflect over the interface. The created specification does not specify any of the security algorithms which may be used.

3.13.5 Specification of a bearer independent protocol for SAT applications to exchange data over the GSM network

Acronym: BIP

References for WI " Bearer independent data transfer "	
Document	Title/Contents
WID	
SMG P-99-186	Work Item Description
Impacted Specifications	
GSM 03.48 GSM 11.10 GSM 11.14	Security mechanisms for SIM application toolkit; Stage 2 Mobile Station (MS) conformance specification Specification of the SIM Application Toolkit (SAT) for the Subscriber Identity Module - Mobile Equipment (SIM-ME) interface
New Dedicated Specifications	
	None.

GSM 11.14 already defines mechanisms for the exchange of data with servers in the network using SMS and USSD. The corresponding bearers (SMS and USSD) are suitable as long as very little amount of data have to be transferred. This work item defines, at the SIM-ME interface, a basic protocol allowing SIM Toolkit applications to determine available bearers and to exchange data by selecting using the most appropriate bearer available (Circuit Switched Data, GPRS, SMS, USSD, etc.).

On the SIM side, the technology now allows the SIM applications themselves to be downloaded over-the-air. The performance of SMS or USSD may not be sufficient for this purpose. On the network side, the required level of performance is available through data calls (CSD and GPRS). On the ME side, the data capability is available on a large scale.

Therefore, it was decided to boost the emergence of value added services based on the SIM Application Toolkit using existing bearers. A mechanism at the interface between the SIM and the ME was defined which provides access to the data bearers supported by the ME. The main requirements were:

- ability for the SIM to use more performant bearer services, at least for data download;
- no impact on hardware and little impact on software for the ME;
- minimum impact on network.

This WI defined, at the SIM-ME interface, a basic protocol allowing SAT applications to determine available bearers and to exchange data by selecting using the most appropriate bearer available (Circuit Switched Data, GPRS, SMS, USSD, etc).

3.13.6 Specification of administrative commands and functions for IC cards

No acronym

References for WI " Administrative commands and functions for IC cards"	
Document	Title/Contents
WID	
P-00-140 (SMG 31)	None.
Impacted Specifications	
	None.
New Dedicated Specifications	
ETSI TS 102 222	Integrated Circuit Cards (ICC);Administrative commands for telecommunications applications

The specification resulting from this work item has been developed by SMG9 as part of its mandate to develop generic IC card specifications and thus had not been allocated a GSM specification number. It specifies the functions and syntax for a set of administrative commands for a telecommunication IC Card. Administrative commands are used during the installation, activation and de-activation of applications. Please note that this specification was handed over to the ETSI Project Smart Card Platform (SCP) in 2000.

The commands defined are compliant to the commands defined in the ISO/IEC 7816 series where corresponding commands in ISO/IEC are available. The commands described are using parts of the functionality of the commands described in the ISO/IEC 7816 series. It is up to the IC Card to provide more functionality than described in the specification. The specification does not cover the internal implementation within the ICC and/or the external equipment.

3.13.7 USIM and UICC requirements

No acronym.

References for WI " USIM and UICC requirements "	
Document	Title/Contents
WIDs	
TP-99084	WI Sheet
Impacted Specifications	
	None
New Dedicated Specifications	
TS 21.111	USIM and IC Card Requirements

This work item creates a high level description of requirements for the 3GPP IC card and its interface to the 3GPP terminal. The document created defines requirements of the USIM (Universal Subscriber Identity Module) and the IC card for 3GPP (UICC). These are derived from the service and security requirements defined in 3GPP 22.01 and 22.00. The USIM is a 3GPP application on an IC card. It inter-operates with 3GPP terminals and provides access to 3GPP services. The document is intended to serve as a basis for the specification of the USIM, the UICC, and the interface to the 3GPP terminal.

3.14 Security related features

3.14.1 Fraud Information Gathering Service

Acronym: FIGS

References for WI " FIGS "

Document	Title/Contents
WIDs	
Not found	WI Sheet
Impacted Specifications	
	None
New Dedicated Specifications	
TS 22.031	Stage 1 of FIGS
TS 23.031	Stage 2 of FIGS

This feature provides the means for the HPLMN to monitor the activities of its subscribers in a VPLMN. The VPLMN collects information about a defined set of activities on monitored subscribers and sends this information back to the HPLMN. This enables the HPLMN to perform service limitation controls such as Operator Determined Barring (ODB) and Immediate Service Termination (see below), to limit their financial exposure to subscribers producing large unpaid bills.

Only Connection-orientated services are covered for Release 99.

3.14.2 Immediate Service Termination

Acronym: IST

References for WI " IST "

Document	Title/Contents
WIDs	
Not found	WI Sheet
Impacted Specifications	
TS 29.002	MAP
New Dedicated Specifications	
TS 22.032	Stage 1 of IST
TS 23.035	Stage 2 of IST

This feature provides the means for the HPLMN to terminate all the activities of an HPLMN subscriber in a VPLMN. If the HPLMN decides (based upon information received via FIGS or other systems) that a roaming subscriber is behaving in a fraudulent or suspicious manner, the HPLMN can terminate all activities of the subscriber, including calls (including transferred and diverted calls) that are in progress.

This procedure can also be used to terminate all the activities of a subscriber when the subscription has ended.

IST implementation is based on two new MAP messages: MAP_IST_ALERT and MAP_IST_COMMAND, defined in TS 29.002. In particular, the MAP_IST_COMMAND is used by the HLR to instruct the MSC (Visited MSC or Gateway MSC) to terminate ongoing call activities for a specific subscriber.

Note that another implementation, based on CAMEL, was envisaged but finally not performed in this Release.

4 GSM Features

4.1 Dual Transfer Mode within GSM and GPRS

“Dual Transfer Mode” (DTM) is also known as "BSS co-ordination of Radio Resource allocation for class A GPRS services - GSM Radio Access " and "BSS co-ordination of Core Network Resource allocation for class A GPRS services -GSM-UMTS Core Network".

Acronym: DTM

References for Work Items on DTM

Document	Title/Contents
WIDs	
2-99-1780 (2-99-H80 from SMG2#32)	WI Description on "BSS co-ordination of Radio Resource allocation for class A GPRS services - GSM Radio Access (R99)"
Impacted Specifications	
04.18	Mobile radio interface layer 3 specification; Radio Resource Control Protocol.
04.60	Mobile Station (MS) - Base Station System (BSS) interface; Radio Link Control/ Medium Access Control (RLC/MAC) protocol.
TS 23.060	GPRS; Service description; Stage 2.
05.01	Physical layer on the radio path; General description.
05.02	Multiplexing and multiple access on the radio path.
05.08	Radio subsystem link control.
03.64	Overall description of the GPRS radio interface; Stage 2.
08.08	Mobile-services Switching Centre - Base Station System (MSC - BSS) interface; Layer 3 specification.
TS 24.007	Mobile radio interface signalling layer 3; General aspects.
TS 24.008	Mobile radio interface layer 3 specification; Core Network Protocols; Stage 3.
New Dedicated Specifications	
TS 03.55	Dual Transfer Mode; Stage 2.

The definition of GPRS class A mode of operation in Releases 97 and 98 was done assuming a total independence between the CS and PS domains. Thus the direct implementation of the standards would have resulted in mobile stations required to operate in two different frequencies simultaneously. The Dual Transfer Mode overcomes this by allowing a simultaneous existence of circuit-switched connection and packet-switched sessions within GSM/GPRS.

This is done by "associating" one or more packet-switched timeslot(s) to the circuit-switched timeslot, or even by sending packet-switched data and circuit-switched voice in the same timeslot, i.e. when half-rate speech is used.

To perform this association, the Base Station Controller (BSC) needs to know the IMSI of the Mobile Station. Consequently, in a similar manner to UMTS, the A interface is modified so that the BSC can be made aware of the IMSI associated with each SCCP connection towards the MSC. With this information, the BSC can do the co-ordination of resources allocated to the circuit-switched and packet-switched domains.

4.2 General Packet Radio Service enhancements

Also called "General Packet Radio Service (GPRS) - radio part (R99)".

Acronym: GPRS enhancements

References for WI "GPRS enhancements"

Document	Title/Contents
WIDs	
	None
Impacted Specifications	
TS 23.064	Overall description of the GPRS radio interface; Stage 2
TS 24.008	Mobile radio interface layer 3 specification
TS 24.060	MS-BSS Interface; Radio Link Control / Medium Access Control (RLC/MAC) protocol
05.02	Multiplexing and multiple access on the radio path
05.05	Radio transmission and reception
05.08	Radio subsystem link control
05.10	Radio subsystem synchronization
05.50	Background for Radio Frequency (RF) requirements
11.21	BSS Radio aspects
New Dedicated Specifications	
	None

GPRS was introduced in Release 97. Release 99 brings a number of essential corrections e.g. on Downlink Power Control, Timing Advance procedure, Cell reselection delay time, PBCCH scheduling, PTCCCH mapping, etc.

A number of specifications were impacted, the most important among them being listed in the table above.

4.3 GSM on 400 MHz Frequency Band

No acronym

References for WI "GSM on 400 MHz Frequency Band"	
Document	Title/Contents
WIDs	
Work_Items_History	Updated WI Sheet
Tdoc SMG2 507/00	GSM in the 400 MHz bands
Impacted Specifications	
02.17	SIM Functional characteristics
03.22	Functions related to Mobile Station in idle mode and group receive mode
03.30	Radio network planning aspects
04.04	Layer 1; General requirements
04.18	Mobile radio interface layer 3 specification; RRC Protocol
04.60	MS-BSS Interface; Radio Link Control / Medium Access Control (RLC/MAC) protocol
05.01	Physical layer on the radio path; General description
05.02	Multiplexing and multiple access on the radio path
05.05	Radio transmission and reception
05.08	Radio subsystem link control
05.10	Radio subsystem synchronization
05.50	Background for Radio Frequency requirements
08.18	BSS SGSN - BSS GPRS Protocol (BSSGP)
08.58	(BSC - BTS) interface; Layer 3 specification
24.008	Mobile radio interface layer 3 specification; Core Network Protocols Stage 3
27.007	AT command set for User Equipment
11.21	BSS Radio aspects
New Dedicated Specifications	
None	

"GSM in the 400 MHz bands" allows to deploy GSM within frequency bands in the range 450 to 500 MHz, previously used for analogue cellular systems.

When GSM in the band 1800 MHz was added to the standard in Release 96, some modifications were done to make the set of specifications less band-dependent. As a continuation for this process, the possibilities to further adapt the specifications toward band free format were considered where appropriate in this work item.

GSM 400 systems are targeted to offer large coverage in rural areas. The work item "GSM in the 400 MHz bands" includes a support for cell ranges up to 120 km by enabling two more bits in "Timing Advance" Information Element.

GSM 400 systems are specified for two frequency allocations. Primary utilisation will be allocations around 450 MHz. For some countries allocations around 480 MHz is possible.

The two bands are:

- GSM 450 Band
 - 450.5 – 457.5 MHz: mobile transmits, base receives;
 - 460.5 – 467.5 MHz: base transmits, mobile receives;
- GSM 480 Band
 - 479 – 486 MHz: mobile transmits, base receives;
 - 489 – 496 MHz: base transmits, mobile receives;

with a carrier spacing of 200 kHz.

Consequently, if we call $F1(n)$ the n^{th} carrier frequency in the lower band, and $Fu(n)$ the n^{th} carrier frequency in the upper band, we have, for the 450 band:

- $F1(n) = 450.6 + 0.2 \cdot (n-125)$ (MHz) $(125 \leq n \leq 159)$
- $Fu(n) = F1(n) + 10$ (MHz)

The value n is the Absolute Radio Frequency Channel Number (ARFCN).

It is reasonable to assume that BTS heights in rural area are higher than in urban area thus minimum coupling loss (MCL) 65 dB is valid assumption in rural areas.

The adoption of GSM 900 or EGSM 900 radio frequency requirements to GSM 450 systems with minimal changes made it easy to adapt standard GSM technology.

It is unnecessary to do any changes to existing GSM 900 modulation mask while it is adapted to GSM 450 systems (both for coordinated and uncoordinated case).

See Tdoc SMG2 190/99 and 595/99 for further info.

4.4 Enhanced Data rates for GSM Evolution

Acronyms:

EDGE	Enhanced Data rates for GSM Evolution
EGPRS	Enhanced GPRS
ECSD	Enhanced Circuit Switch Data
COMPACT	Deployment of services in spectrum below 1 MHz

References for WI "EDGE"

Document	Title/Contents
WIDs	
SMG2 331/97	EDGE feasibility study Version 1.0
SMG 1147/97	Work item description for EDGE – NSS
SMG 1148/97	Work item description for EDGE – BSS
SMG2 872/99	EDGE Compact and support for E-GPRS in ANSI-136 networks
Impacted Specifications	
02.34	
02.60	GPRS Service Description; Stage 1
03.30	Radio Planning aspects
05.10	Radio Subsystem synchronization
05.50	Background for RF requirements
11.26	Repeaters
New Dedicated Specifications	
10.59	"Project scheduling and open issues for EDGE"

Enhanced Data Rates for GSM Evolution (EDGE) refers to the introduction of new modulation techniques based on 8-PSK (Phase Shift Keying), both for uplink and downlink, in order to evolve data services in GSM while reusing as much of the physical layer as possible. In packet, bitrates approximately three times higher than for standard GPRS are enabled. In circuit, the user data rates are limited to 64 kbit/s, i.e. not more than without EDGE, but achievable with smaller number of time slots and relatively simple MS implementation.

Existing services like GPRS and HSCSD are enhanced by the new physical layer, but services themselves are not modified; therefore, EDGE is introduced in the existing specifications without creating new ones.

Two work items introduce EDGE into GSM, i.e. EDGE Network sub system (NSS) and EDGE Basestation sub system (BSS). The EDGE BSS work item provides a platform to employ new modulation techniques, whereas the EDGE NSS work item defines the network changes to facilitate the physical layer.

EDGE was developed in two phases, and only Phase 1 is part of Release 1999. EDGE Phase 1 includes Enhanced GPRS (EGPRS) Phase 1, Enhanced CSD (ECSD) Phase 1, EGPRS COMPACT and Support for EGPRS in ANSI-136 networks. The new physical layer based on 8-PSK modulation is introduced and EGPRS and ECSD facilitate the new modulation in single and multi slot constellation.

No tight link is defined between 8-PSK and GMSK classes.

EDGE is independent of the frequency bands, so it can be deployed e.g. in the 900 and the 1900 MHz bands.

4.4.1 Enhanced GPRS

Acronym: EGPRS

References for WI " Enhanced GPRS"

Document	Title/Contents
WIDs	
<i>See common references for EDGE</i>	
Impacted Specifications	
02.60	GPRS Service Description; Stage 1
03.60	GPRS Service Description; Stage 2
03.64	Overall description of the GPRS radio interface; Stage 2
04.08	Mobile radio interface layer 3 specification
04.18	Mobile radio interface layer 3 specification; RRC Protocol
04.60	MS-BSS Interface; Radio Link Control / Medium Access Control (RLC/MAC) protocol
05.01	Physical layer on the radio path; General description
05.02	Multiplexing and multiple access on the radio path
05.03	Channel coding
05.04	Modulation
05.05	Radio transmission and reception
05.08	Radio subsystem link control
11.21	BSS Radio aspects
New Dedicated Specifications	
None	

With the introduction of EGPRS, bitrates approximately three times higher than for standard GPRS are enabled.

The architectural impacts of EGPRS are related to the GPRS Packet Control Unit (PCU) and Channel Codec Unit (CCU). The GPRS specifications allows the placement of the PCU either in the BTS, BSC or GSN, whereas the CCU is always placed in the BTS. When the PCU is placed remote to the BTS, information between the CCU and the PCU is transferred in PCU frames. The CCU may control some of the functions in the remote PCU and vice versa through inband signalling using the PCU frames.

The functions of the CCU are channel coding, including FEC and interleaving, and radio channel measurement functions, including received quality level, received signal level and information related to timing advance measurements. The PCU is responsible for LLC PDU segmentation and re-assembly, ARQ (Automatic Repeat reQuest) functions (including RLC block ACK/NACK), PDCH scheduling, channel access control, and radio channel management functions.

GPRS and EGPRS employ the same physical layer, except for the PDTCH. In the case of EGPRS, the modulation format is inherently signalled by the rotation factor of the training sequences as specified in GSM 05.04 and GSM 05.02, enabling blind detection in the receiver. The Radio Block structure for data transfer is different for GPRS and EGPRS, whereas the same Radio Block structure is used for control messages. For detailed definition of radio block structure, see GSM 04.60. Other changes included the introduction of ARQ, Incremental Redundancy mechanism, new MCS (Modulation and Coding Schemes).

Nine new modulation and coding schemes, MCS-1 to MCS-9, are defined for the EGPRS packet data traffic channels. For all EGPRS packet control channels, the corresponding GPRS control channel coding is used. Coding schemes MCS-1 to MCS-9 are mandatory for MSs supporting EGPRS. A network supporting EGPRS may only support some of the MCSs. The selection of MCS is controlled by the network. The coding is based on a punctured convolutional code with rate 1/3, and for each MCS, there are 2 or 3 puncturing schemes. For incremental redundancy, an incorrectly received RLC/MAC block is retransmitted using a different puncturing scheme. In the case of MCS-5-7 and MCS-6-9, retransmissions with incremental redundancy can even use a different MCS. Transmission and reception data flows are same for GPRS and EGPRS, except for EGPRS MCS-7 to MCS-9, where four normal bursts carry two RLC blocks (two RLC/MAC blocks per radio block, one RLC block within two bursts).

Type II hybrid ARQ is mandatory in EGPRS MS receivers and the associated performance requirements are specified in GSM 05.05.

EGPRS supports both a pure link adaptation mode and a combined link adaptation and incremental redundancy mode.

The incremental redundancy mode requires no extra signalling between the CCU and PCU compared to the link adaptation mode. The incremental redundancy mode however requires an enhanced CCU functionality. RLC/MAC protocol is the most affected by EDGE.

EGPRS also impacts the Radio Resource Management (RR), Mobility Management (MM), and Session Management (SM), leading to changes on GSM 04.08 and 04.60.

An extended Channel Coding Command (CCC) is required for EGPRS since there are 8 different MCSs. In addition to this, an extra 'retransmission resegment' field (1 bit) should be sent along with this command. This field tells the MS whether it should resegment retransmissions to an MCS close to the one indicated in the CCC (e.g. used in LA mode or when memory shortage in BS in IR mode), or stick to the initially used MCS (used in IR mode when memory is available).

EGPRS also requires a modified/extended link quality measurement report.

For services where delay is the most crucial quality parameter but some errors are acceptable, e.g. for some real time services, the retransmissions associated with the acknowledged mode are unacceptable, since the delay would be too large. Therefore EGPRS is also able to operate in unacknowledged mode, i.e. without retransmissions. To achieve an acceptable BLER or BER without ARQ, the link adaptation switching points in the proposed scheme are moved to yield the desired robustness in the non-acknowledged mode.

There are two modulation modes for PDCH in EGPRS: Linear 8-PSK and GMSK. GMSK is used as fallback when 8-PSK is not appropriate for the current channel conditions.

Two classes of EDGE-capable mobiles are defined:

- Class 1: The two modulation modes can be used in the downlink, while only GMSK is used in the uplink.
- Class 2: The two modulation modes can be used both on uplink and downlink.

Other channels than PDCH always use GMSK modulation.

The first downlink block in each multiframe must be modulated with GMSK if a GPRS terminal is allocated on the same timeslot.

Channel coding, puncturing, interleaving, CRC and burst mapping lead to changes on GSM 05.03.

See Tdoc SMG2 657/99 "EDGE: Concept Proposal for Enhanced GPRS" for more information.

4.4.2 Enhanced Circuit Switched Data

Acronym: ECSD

References for WI " Enhanced Circuit Switched Data"

Document	Title/Contents
WIDs	
<i>See common references for EDGE</i>	
Impacted Specifications	
04.04	Layer 1; General requirements
04.08	Mobile radio interface layer 3 specification
04.18	Mobile radio interface layer 3 specification; RRC Protocol
04.60	MS-BSS Interface; Radio Link Control / Medium Access Control (RLC/MAC) protocol
05.01	Physical layer on the radio path; General description
05.02	Multiplexing and multiple access on the radio path
05.03	Channel coding
05.04	Modulation
05.05	Radio transmission and reception
05.08	Radio subsystem link control
08.08	(MSC - BSS) interface; Layer 3 specification
08.58	(BSC - BTS) interface; Layer 3 specification
08.60	Inband control of remote transcoders and rate adaptors for Enhanced Full Rate (EFR) and full rate traffic channels
New Dedicated Specifications	
None	

ECSD supports both transparent and non-transparent services, up to 64 kbit/s and 57.6 kbit/s respectively. The user data rates are limited in Phase 1 ECSD specifications to 64 kbit/s. This means that the maximum data rates are not increased from the rates supported in current GSM. On the other hand, the same services are achievable with smaller number of time slots and relatively simple MS implementation making them more attractive to various data applications.

ECSD supports interworking with audio modems and ISDN services on various rates. Group 3 fax services are not supported with ECSD, because existing GSM channels are adequate for G3 fax support. If the digital extension of G3 and G4 fax is more widely adopted in the future, the fax services can be reconsidered.

One of the main applications for ECSD are the video applications. Besides data rates, there are other requirements for video transmission: video services usually include several components, each of them with varying QoS requirements. Figures below show two concepts in terms of QoS of providing video telephony service. The differences between the concepts are in the way of ensuring the QoS for different components: audio, video and data.

For non-transparent (NT) data, $BER < 10^{-3}$ requirement is assumed. Corresponding value for transparent (T) data is $BER < 10^{-4} \dots 10^{-5}$.

The ECSD architecture is largely based on HSCSD transmission and signalling. This ensures a minimum impact on existing specifications.

New parameters are required in signalling messages due to new modulation and channel coding schemes, but the signalling mechanism is the same as in HSCSD. Also fall back to existing HSCSD and single slot data services is supported in case the network/MS does not support ECSD.

Link adaptation (LA) between channel coding schemes in 8-PSK modulation and between GMSK and 8-PSK coding schemes require new algorithms in BSC. Link adaptation is not a mandatory feature in current GSM, but particularly in high data rate call using transparent mode connection LA becomes essential in order to provide the good enough service over large coverage areas.

Link adaptation algorithms used depend on the service data rates supported in the network and they are not specified in GSM specifications.

The required C/I for both GMSK and 8-PSK modulation with different RX_QUAL values (0-7) shows that the step size between quality classes is about 2 to 4 dB and dynamic range is about 20 dB for both modulations. Link simulations show that even C/I of 25 dB is enough in 38.8 kbit/s service for coded BER of 10⁻⁵. In practice it is very difficult to achieve higher C/I values than 30 dB. On the other hand, in the lower end C/I of 10 dB does not provide good enough service for 29 kbit/s. This would imply that the dynamical range in current measurements is sufficient for 8-PSK and link adaptation to GMSK should be performed well before the quality of the connection falls as low as this.

In practice, the granularity with BER based reporting and use of three bits for RX_QUAL levels, as in current GSM, is enough for covering the operative quality range.

It is possible to improve the link adaptation performance by replacing BER with C/I based reporting and introducing new measurement metrics like C/I variance used in GPRS. Including RX_LEV reports from more than six neighbouring cells also improves the performance of the link adaptation particularly for multi-band mobiles. These enhancements, however, require more drastic changes in signalling and are seen as a general improvement to circuit switched measurements rather than EDGE specific change. See Tdoc SMG2 670/99 "ECSD Concept Evaluation" for more information.

4.4.3 Support for EGPRS in ANSI-136 networks" and "EDGE Compact" (for ANSI-136 networks only)

Acronym: EDGE Compact

References for WIs "Support for EGPRS in ANSI-136 networks" and "EDGE Compact"

Document	Title/Contents
	WIDs
SMG2 826/99	Work Item: "EDGE Compact and support for E-GPRS in ANSI-136 networks"
	Impacted Specifications
03.22	Functions related to Mobile Station (MS) in idle mode and group receive mode
03.30	Radio network planning aspects
03.64	Overall description of the GPRS radio interface; Stage 2
04.03	MS - BSS interface; Channel structures and access capabilities
04.04	Layer 1; General requirements
04.08	Mobile radio interface layer 3 specification
04.18	Mobile radio interface layer 3 specification; RRC Protocol
04.60	MS-BSS Interface; Radio Link Control / Medium Access Control (RLC/MAC) protocol
05.01	Physical layer on the radio path; General description
05.02	Multiplexing and multiple access on the radio path
05.03	Channel coding
05.04	Modulation
05.05	Radio transmission and reception
05.08	Radio subsystem link control
05.10	Radio subsystem synchronization
05.50	Background for Radio Frequency (RF) requirements
08.08	(MSC - BSS) interface; Layer 3 specification
08.58	(BSC - BTS) interface; Layer 3 specification
08.60	Inband control of remote transcoders and rate adaptors for Enhanced Full Rate (EFR) and full rate traffic channels
11.11	Mobile Equipment (SIM - ME) interface
11.21	BSS Radio aspects
24.008	Core Network Protocols; Stage 3
	New Dedicated Specifications
	None

4.4.3.1 Framework

In January 1998, the ANSI-136 TDMA community, through the UWCC and TIA TR45.3, evaluated and adopted EGPRS as a key part of its high speed data evolution. Consequently, a large part of EGPRS was incorporated as "136 High Speed (136HS)" into the TDMA IMT-2000 proposal called "UWC-136". There were two key characteristics that 136HS allowed: data rates up to 384 kbit/s and initial deployment in less than 1 MHz of spectrum. The TDMA Community has studied how to further enhance 136HS such that it would be closer to ETSI-EGPRS to better facilitate global roaming, while also keeping the desire for initial deployment in less than 1 MHz of spectrum. The result of this effort is this Work Item, which intends to harmonise the SMG work with the one in Universal Wireless Communication Consortium (UWCC) to introduce the support of EDGE and GPRS in ANSI-136 networks.

It includes all necessary changes for the support of the EDGE Compact concept described below (which is an EDGE implementation in a limited frequency band), and the interaction with the ANSI-41/136 network. It also includes the changes for the support of roaming between EDGE Compact and classical EDGE (EDGE Classic) implementations.

The work item includes in total the work on four different areas:

- Support of GSM on 850 MHz, re-using the work of the work item “GSM on 400 MHz Frequency Band” described above.
- EDGE Compact, developed in the next section.
- Signalling support for interaction with the ANSI-41/136 network.
- Support for roaming between E-GPRS and GPRS136HS EDGE .

4.4.3.2 EDGE Compact

COMPACT can be deployed in 600 kHz (plus guard) of spectrum, and looks as an overlay system to an existing ANSI-136 network. As such, COMPACT is independent of the ANSI-136 system, which facilitates roaming of EGPRS only mobile stations. It also allows operators to deploy different infrastructure vendors for their data solution from their voice network.

For operators having more available bandwidth, the TDMA Community also supports the development of ETSI-EGPRS (referred to as "EGPRS Classic"), requiring 2.4 MHz of initial spectrum. The support of both COMPACT and EGPRS Classic under what is called EGPRS-136 eases the convergence of GSM and ANSI-136 systems.

Integration of GPRS with ANSI-136 is logically accomplished by the addition of the GPRS network nodes SGSN and GGSN to the ANSI-41 circuit-switched network.

EGPRS (i.e. EGPRS Classic) terminals on the 850 or 1900 MHz band will also support COMPACT to facilitate roaming.

COMPACT terminals would also support EGPRS Classic to facilitate roaming.

The idea is that a mobile supporting TDMA band (850 and 1900) shall support both Compact and Classic EDGE (in USA). EDGE Compact also includes specification information for mixed mode operation at 850 and 1900 MHz. (MXM 850 and MXM 1900). 850 MHz and 1900 MHz mixed-mode is defined as a network that deploys both 30 kHz RF carriers and 200 kHz RF carriers in geographic regions where the Federal Communications Commission (FCC) regulations are applied.

EDGE Classic uses the same as EDGE with 4x12 except BCCH on TN0.

EDGE Compact uses BS sync and modified control channel. In EDGE Compact, the PSCH is different due to 52 multiframe structure, and the cell reselection is modified and a new measurement method is used. New broadcast information info on 200 kHz for 30 kHz voice page is also used.

Estimations mention to save 20 to 25% load with Edge compact compared to Edge classic because of DTX.

Note that EDGE Compact was developed to meet the UWCC requirements but can be implemented in other frequency bands with limited spectrum, e.g. GSM400.

See tdoc SMG2 EDGE 322/99, “EDGE compact concept proposal” for more information.

5 Charging and Testing

These two domains of activity have been grouped here as they do not represent any new Feature, according to the definition provided at the beginning of this document. They are however essential activities, without which no Feature can operate and/or generate revenues.

5.1 Charging

Acronym: OAM-CH

References for WI "Charging"

Document	Title/Contents
WIDs	
SP 99271	Charging and accounting
SP-99581	SA5 Year 2000 Work plan
Impacted Specifications	
	None
New Dedicated Specifications	
TS 22.115	Service Aspects Charging and billing
TS 23.121	Architectural requirements for Release 1999
TS 32.005	Telecommunications Management; Charging and billing; 3G call and event data for the Circuit Switched (CS) domain
TS 32.015	Telecommunications Management; Charging and billing; 3G call and event data for the Packet Switched (PS) domain

This feature creates the Charging framework to be followed by the 3G Telecom Management standardisation. The main aspects of this work are the transfer of Circuit and Packet Switched Charging from GSM to UMTS/3G, accommodating the UMTS/3G-specific respectively Additional functionality.

5.2 Operations, Administration, Maintenance and Provisioning

Acronym: OAM&P

References for WI "OAM&P"

Document	Title/Contents
WIDs	
SP-99272	Fault management
SP-99273	Configuration management
SP-99274	Performance management
SP-99581	SA5 Year 2000 Work plan
Impacted Specifications	
	None
New Dedicated Specifications	
TS 32.101	Telecommunication management: Principles and high level requirements
TS 32.102	Telecommunication management; Architecture
TS 32.104	3G Performance Management
TS 32.106-1	Telecommunication management; Configuration Management (CM) Part 1: Concept and requirements
TS 32.106-2	CM Part 2: Notification Integration Reference Point (IRP): Information Service
TS 32.106-3	CM Part 3: IRP Common Object Request Broker Architecture (CORBA) solution set
TS 32.106-4	CM Part 4: IRP Common Management Information Protocol (CMIP) solution set
TS 32.106-5	CM Part 5: IRP Information model (including Network Resource Model NRM))
TS 32.106-6	CM Part 6: IRP Common Object Request Broker Architecture (CORBA) solution set
TS 32.106-7	CM Part 7: IRP Common Management Information Protocol (CMIP) solution set
TS 32.106-8	CM Part 8: Name convention for Managed Objects
TS 32.111-1	Telecommunication management; Fault Management; Part 1: 3G fault management requirements
TS 32.111-2	Part 2: Alarm IRP: Information Service
TS 32.111-3	Part 3: Alarm IRP: Common Object Request Broker Architecture (CORBA) solution set
TS 32.111-4	Part 4: Alarm IRP: Common Management Information Protocol (CMIP) solution set

This feature creates the OAM&P framework to be followed by the 3G Telecom Management standardisation and met by all specifications produced by the 3GPP groups (e.g. SA5, RAN O&M, GERAN O&M, etc.) pertinent to UMTS Telecom Management.

The major functionalities introduced by the Telecom Management specifications in this release are:

- Telecom Management Principles, Requirements and Architecture: X.25 and IP Network Layer protocols ; Introduction of Security Management ; Introduction of Integration Reference Point (IRP) Framework ; Telecom Management Architecture and Architecture of Radio Management Interface.
- Performance Management: X.25 Consistency; synchronization; performance measurement parameter definition.
- Configuration Management: Notification IRP, Basic Configuration Management Interfaces IRP and high level Network Resource Management (NRM) IRPs.
- Fault Management: Alarm Management Interface IRP.

5.3 USIM/UICC Testing

5.3.1 Terminal tests for the UICC Interface

No acronym.

References for WI " Terminal tests for the UICC Interface "	
Document	Title/Contents
WIDs	
TP-99184	WI Sheet
Impacted Specifications	
	None
New Dedicated Specifications	
TS 31.120	UICC-Terminal Interface; Physical, Electrical and Logical Test Specification

This work item creates a terminal test specification for the interface between the UICC and the terminal. It was originally based on the tests contained in GSM 11.10-1 clause 27.

The aim is to ensure interoperability between an UICC and a Terminal independently of the respective manufacturer, card issuer or operator. Application specific tests for applications residing on an UICC are specified in document 3G TS 31.121 (presented in the next section).

TS 31.120 specifies the tests of:

- physical characteristics of the UICC;
- the electrical interface between the UICC and the Terminal;
- the initial communication establishment and the transport protocols;
- the application independent procedures.

5.3.2 USIM application test specification

No acronym.

References for WI " USIM application test specification "	
Document	Title/Contents
WIDs	
TP-99184	WI Sheet
Impacted Specifications	
	None
New Dedicated Specifications	
TS 31.121	UICC-terminal interface; USIM application test specification

The work item covers the creation of the application test specification. It was originally based on the tests contained in GSM 11.17.

The aim is to ensure interoperability between an UICC and a terminal independently of the respective manufacturer, card issuer or operator. Aspects related to the administrative management phase of the UICC are not defined. Any internal technical realisation of either the UICC or the Terminal is only specified where these are reflected over the interface.

The UICC (Universal IC Card)-Terminal Interface Conformance Test Specification between the 3rd Generation Terminal and USIM (Universal Subscriber Identity Module) as an application on the UICC and the Terminal for 3G telecom network operation covers the following aspects:

- the default setting of the USIM;
- the applicability of each test case;
- the test configurations;
- the conformance requirement and reference to the core specifications;
- the test purposes;
- a brief description of the test procedure and the specific acceptance criteria.

5.3.3 USIM conformance test specification

No acronym.

References for WI " Terminal tests for the UICC Interface "	
Document	Title/Contents
WIDs	
	None
Impacted Specifications	
	None
New Dedicated Specifications	
TS 31.122	USIM conformance test specification

TS 31.122 provides the Conformance Test Specification for a Universal IC Card (UICC) defined in 3G TS 31.101 with Universal Subscriber Identity Module (USIM) defined in 3G TS 31.102.

5.3.4 SIM toolkit test specification

No acronym.

References for WI " SIM toolkit test specification "	
Document	Title/Contents
WIDs	
SMG P-99-416	Work Item Sheet
Impacted Specifications	
	None
New Dedicated Specifications	
TS 11.10-4	Mobile Station (MS) conformance specification; Part 4: Subscriber Interface Module (SIM) application toolkit conformance specification

SIM Application Toolkit has a major impact on ME design and enhances the SIM/ME interface in a comprehensive way. To ensure the proper functionality of the SIM/ME interface a SIM Application Toolkit Test Specification is required.

The specification only contains tests for optional features of the SIM/ME interface (no network related signalling issues are involved) and does not form the basis for any type approval or regulatory tests.

5.4 3G User Equipment (UE) Testing

No acronym.

References for WI " UE Testing "

Document	Title/Contents
WIDs	
	None
Impacted Specifications	
	None
New Dedicated Specifications	
TS 34.108	Common test environments for User Equipment (UE): conformance testing
TS 34.121	Terminal conformance specification; Radio transmission and reception (FDD)
TS 34.122	Terminal Conformance Specification; Radio Transmission and Reception (TDD)
TS 34.123-1	User Equipment (UE) conformance specification; Part 1: Protocol conformance specification
TS 34.123-2	User Equipment (UE) conformance specification; Part 2: Implementation Conformance Statement (ICS) proforma specification
TS 34.123-3	User Equipment (UE) conformance specification; Part 3: Abstract Test Suite (ATS)

The aim of the User Equipment (UE) testing related work –not officially defined as a Work Item- is to specify Conformance Tests for a 3rd Generation UE to be recognised as “3GPP-standard compliant”. Once these tests are defined, a 3GPP-external body, namely the GCF (Global Certification Forum), delivers certificates to prove that a UE has correctly passed the tests and is then conform to the 3GPP standard.

TS 34.108 contains definitions of the common test environments¹³.

TS 34.121 specifies the measurement procedures for the conformance test of the UE that contain transmitting characteristics, receiving characteristics and performance requirements in addition to requirements for support of RRM (Radio Resource Management) in FDD mode. Tests are only applicable to those mobiles that are intended to support the appropriate functionality. In other terms, only a UE declared to support a given feature shall be tested for this feature. TS 34.122 is equivalent to TS 34.121 for the TDD mode (in both the 3,84 Mcps TDD Option and 1,28 Mcps TDD Option).

TS 34.123, composed of three parts, actually specifies the protocol conformance testing for the 3G UE. Part 1 describes the overall test structure. Part 2 contains the applicability of each test case defined as the “Implementation Conformance Statement (ICS) proforma”, in compliance with the relevant requirements, and in accordance with the relevant guidance given in ISO/IEC 9646-7 and ETS 300 406. Part 3 specifies the protocol conformance testing in TTCN for the 3G UE at the Uu interface.

More precisely, all of the following aspects are defined by 34.123:

- the overall test structure and test configurations (part 1)
- the conformance requirement and reference to the core specifications (part 1)
- the test purposes (part 1)
- a brief description of the test procedure, the specific test requirements and short message exchange table (part 1)
- the applicability of each test case (part 2)
- a detailed description of the expected sequence of messages (part 3)
- the Implementation Conformance Statement (ICS) (part 2)

Part 3 defines the TTCN test specification and design considerations in Abstract Test Suites based on the test cases specified in prose in part 1. The following aspects are covered:

- the overall test suite structure and the testing architecture
- the test methods and PCO definitions

¹³ The “common test environments” defined in TS 34.108 are: reference conditions and test signals, default parameters, reference radio bearer configurations used in radio bearer interoperability testing, common radio bearer configurations for other test purposes, common requirements for test equipment and generic set-up procedures for use in UE conformance tests

- the test configurations
- the design principles, assumptions, and used interfaces to the TTCN tester (SS: System Simulator)
- TTCN styles and conventions
- the partial PIXIT proforma
- the TTCN.MP and TTCN.GR forms for the mentioned protocols tests

6 GSM Features transposed to UMTS

This section contains the pre-Release 99 GSM Features which have been directly adapted to UMTS, without any sensible improvement.

6.1 Cell Broadcast Service

Acronym: CBS

References for WI " Cell Broadcast Service "	
Document	Title/Contents
WIDs	
TP-000022	WI Sheet
Impacted Specifications	
TS 23.041	Technical realisation of Cell Broadcast Service (CBS)
New Dedicated Specifications	
	None

This work item refers to the applicability of the Cell Broadcast Service (as defined for GSM network) to 3G networks.

6.2 GSM Mobile Number Portability EURO MNP / North American MNP

Acronym: MNP

References for WI "MNP"	
Document	Title/Contents
WIDs	
WI	Roll-over WI from R98 (02.66)
Impacted Specifications	
TS 22.066	Support of Mobile Number Portability (MNP); Stage 1
New Dedicated Specifications	
	None

Mobile Number Portability (MNP) refers to the ability for a mobile subscriber to change of PLMN operator within the same country whilst retaining his/her original MS ISDN number (MSISDN). Note that the IMSI is changed, only MSISDN is kept.

This feature was introduced in Release 98. The only value added by Release 99 is the addition of requirements for North American Service Provider Number Portability: North American GSM Number Portability (NAGNP) is the ability for a subscriber to change subscription between North American GSM networks and other subscription networks within an FCC regulated geographical area within North-America.

6.3 Automatic Establishment of Roaming Relations

No acronym

References for WI " Automatic Establishment of Roaming Relations "

Document	Title/Contents
WIDs	
	None
Impacted Specifications	
TS 22.101	UMTS Service Principles
New Dedicated Specifications	
TR 22.971	Automatic Establishment of Roaming Relations

This feature consists of a framework for commercial and technical interworking between UMTS Home Environments and Serving Networks who have no direct prior commercial agreements with each other. This avoids the 2 to 4 weeks which were previously needed to perform a standard set of tests written by MoU committees SERG and TADIG to check the functions of basic operation and billing record formats.

The work in R99 was based on TS 22.71 and some semantic changes to the wording were made; e.g. changing Service Provider to Home Environment. In the event, the report concluded that no special standardisation work was required to facilitate Automatic Establishment of Roaming Relationships because these can be implemented with existing standards and procedures.

6.4 Advanced addressing

No acronym

References for WI " Advanced addressing "

Document	Title/Contents
WIDs	
S1-99136	WI Sheet "Advanced Addressing"
Impacted Specifications	
TS 22.101	UMTS Service Principles
New Dedicated Specifications	
TS 22.75U	Advanced Addressing
TR 22.975	Advanced Addressing

This feature consists of the UMTS advanced addressing scheme for numbering and addressing for UMTS, and example directory, application and translation mechanisms which could be used to enhance the service to the customer.

The work in R99 was based on the R98 TS 22.75U v 3.0.0. The only value added information was the deletion of the term International Mobile User Identifier (IMUI) and the change from International Mobile Station Identifier to International Mobile Subscriber Identity.

6.5 UMTS Numbering, Addressing and Identities

No acronym

References for WI " UMTS Numbering, Addressing and Identities "

Document	Title/Contents
WIDs	
	None
Impacted Specifications	
TS 22.101	UMTS Service Principles
New Dedicated Specifications	
	None

The work was done on this WI in R99 in SA resulting in three CRs to 22.101. The output from the work was included in the numbering section of 22.01 (19r1). Also new requirements for Single and Multiple Numbering scheme was added (CR 20 and 21).

6.6 Lawful Interception

Acronym: LI

References for WI " LI "	
Document	Title/Contents
WIDs	
Not found	WI Sheet
Impacted Specifications	
	None
New Dedicated Specifications	
TS 33.106	Lawful Interception Requirements (Stage 1)
TS 33.107	Lawful Interception Architecture and Functions (Stage 2)

The aim of this feature is to define an interception system in UMTS that supports a number of regional interception regulations. Regional interception requirements shall be met in using specific (regional) mediation functions allowing only required information to be transported.

7 “Features” not bringing any additional service

7.1 Reports

7.1.1 Quality of Service

Acronym: QoS

References for WI " QoS"	
Document	Title/Contents
WIDs	
SMG 98-0781	Proposed WI on End To End UMTS QoS Management
Impacted Specifications	
	None
New Dedicated Specifications	
TS 23.107	Quality of Service (QoS) concept and architecture
TR 23.907	QoS Concept and Architecture

This feature introduces a complete set of terms related to the transport of application data (or “user information”): the different types of “bearers” used in UMTS are defined. It also specifies the Quality of Service (QoS) attributes for some of the bearer types, in particular for the "GPRS Bearer Service" (also called “UMTS Bearer”).

This feature is not a service offered to the end user nor to the network operator but is a framework to organise the work related to Quality of Service. A guaranteed end-to-end Quality of Service in the PS domain will not be provided before Release 5.

The terms introduced by this feature are shown in the following figure.

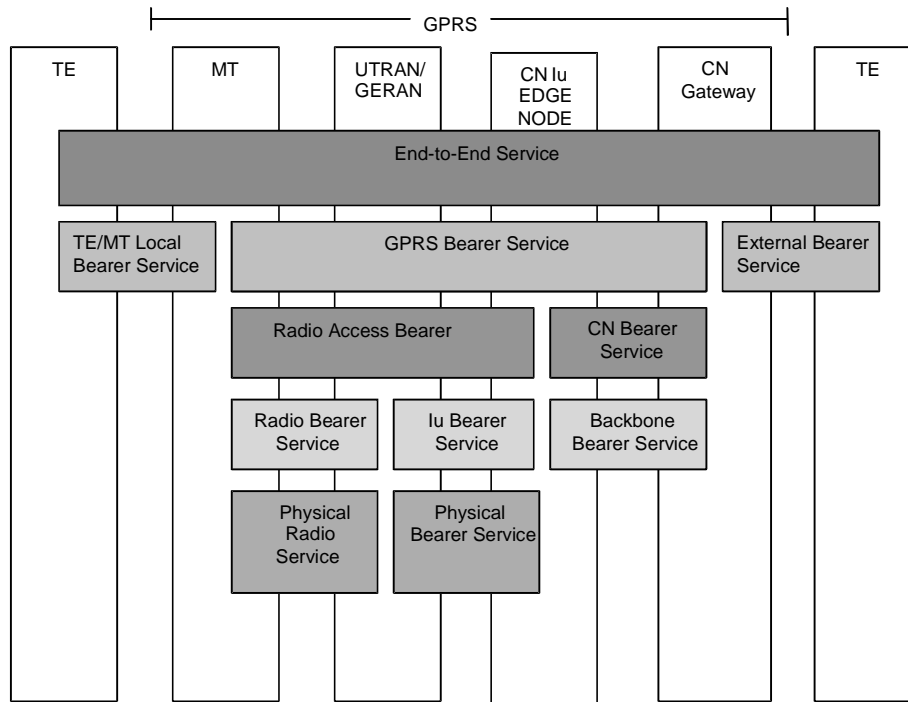

Terminology introduced by the “QoS” Feature

Four different classes of QoS are defined:

- Conversational class: a bearer of this QoS class guarantees the time variation between the incoming and the outgoing packets transported by the bearer, and offers stringent and low delay. It is typically used for conversational services (hence the name...), like (multimedia) telephony.
- Streaming class: the time variation is still guaranteed, but the delay is not as low as in the conversational class, and is typically used for streaming video.
- Interactive class: the request and response are guaranteed within a certain period, while the payload content is preserved. It is to be used e.g. for Web browsing.
- Background class, to be used when the destination is not expecting the data within a certain time, but where the payload content has to be preserved. It has to be used e.g. for background download of e-mail.

For each class, a given set of attributes applies. This set is chosen from a full list of attributes defined for each type of bearer, e.g. the attributes are different for the “GPRS/UMTS Bearer” and for the “Iu Bearer”. The attributes applicable to the “GPRS/UMTS Bearer” and to the “Radio Access Bearer”, defined extensively in this Release, are e.g.: the maximum and guaranteed bit rates, the delivery order, the residual BER, the transfer delay, the traffic handling priority, the allocation/retention priority, etc.

Further definitions can be found in TS 23.107.

The mapping between attributes of different bearer types is partly defined in the standard, e.g. the mapping from GPRS/UMTS Bearer attributes to Radio Access Bearer attributes is defined, whereas the mapping from end-to-end (application) attributes to GPRS/UMTS Bearer attributes is not defined in this Release (not until Release 5). Also the mapping from GPRS/UMTS Bearer attributes to CN Bearer attributes is an operator's choice.

7.1.2 Noise Suppression for AMR

Acronym: AMR-NS

References for WI " AMR - NS"

Document	Title/Contents
SA4_Work_Items_History	WI Sheet
Impacted Specifications	
	None
New Dedicated Specifications	
TS 06.77	Minimum Performance Requirements for Noise Suppressor Application to the AMR Speech Encoder
TR 06.78 ¹⁴	Results of the AMR Noise Suppression Selection Phase

The scope of this feature was to introduce an algorithm to cancel the noise in UMTS telephony service. After an extensive selection phase, described in TR 06.78 "Results of the AMR Noise Suppression Selection Phase", no candidate algorithm fulfilled *all* the quality requirements set for this exercise, hence no standard Noise Suppressor Application to the AMR Speech Encoder was selected.

Nevertheless, TS 06.77 "Minimum Performance Requirements for Noise Suppressor Application to the AMR Speech Encoder" was approved, and can be utilised by the suppliers wishing to provide evidence that their product fulfils a "minimum set of requirements". Results from subjective and/or objective tests conducted by professional labs on behalf of an aspiring supplier can be provided to 3GPP SA4 group for endorsement of a proprietary AMR-NS algorithm. The endorsement means that, based on the test results presented to the WG, SA4 acknowledges that the proposed proprietary algorithm meets the recommended minimum performance requirements as set out in TS 06.77. A statement of this acknowledgement is then included in the following TSG SA meeting report. No AMR-NS algorithm itself is specified nor standardised in 3GPP, i.e. it must be stressed that the "endorsement" does not have such meaning. See TS 06.77 for details.

7.1.3 User Equipment Capability Requirements

No acronym

References for WI "User Equipment Capability Requirements"

Document	Title/Contents
WIDs	
TP-000022	WI Sheet
Impacted Specifications	
	None
New Dedicated Specifications	
TR 21.904	User Equipment Capability Requirements (UCR)

The Requirements for UE Capability have been brought together from other Working Groups, to provide an assessment of the necessary capabilities for a UE to "exist" in a 3GPP network, and also to provide certain services (e.g. speech, fax, SMS).

This document defines a baseline set of capability requirements that enable all terminals to "register" with all applicable 3GPP networks (depending on the availability of a appropriate subscription). It describes all the functions that a terminal must perform in order to "exist" within a 3GPP network. These functions are used to derive requirements for all aspects of terminal baseline capability. This document also identifies different service capabilities and the functions that a terminal must perform in order to access a service. The actual capabilities that a terminal must possess to meet these requirements are listed in the Annexes and described in the referenced implementation specifications. This document introduces the concept of "service-less terminal" which can exist in the network but provides no user service. Although this is not a marketable terminal type, it describes from the standardisation viewpoint a baseline set of capabilities to which specific service-related terminal capabilities can then be added.

7.1.4 Electrical safety requirements and regulations

No acronym

¹⁴ Officially, TSs 06.77 and 06.78 only apply to GSM. They did not apply to UMTS until Rel-4, when they were converted to 26.077 and 26.078.

References for WI " Electrical safety requirements and regulations "

Document	Title/Contents
WIDs	
TP-000022	WI Sheet
Impacted Specifications	
	None
New Dedicated Specifications	
TR 34.907	Electrical safety requirements and regulations

A Technical Report was produced providing information on electrical safety requirements and regulations covering 3G mobile phones in each country and region. The document summarizes the difference between international standards and national standards relevant to IEC60950 and also refers to regulations for conformity assessment due to the different regulatory environments in different countries / regions. The document does not define any new electrical safety requirements.

7.1.5 Specific Absorbtion Rate (SAR) requirements and regulations in different regions

No acronym

References for WI " SAR requirements and regulations in different regions "

Document	Title/Contents
WIDs	
TP-000022	WI Sheet
New Dedicated Specifications	
TR 34.925	Specific Absorbtion Rate (SAR) requirements and regulations in different regions

A Technical Report was produced identifying existing Specific Absorbtion Rate (SAR) requirements and regulations for different countries and regions. The document does not define any new requirements, it does just list the existing ones.

7.1.6 Multi-mode UE issues

No acronym

References for WI " Multi-mode UE issues "

Document	Title/Contents
WIDs	
TP-000022	WI Sheet
Impacted Specifications	
	None
New Dedicated Specifications	
TR 21.810	Report on multi-mode UE issues; ongoing work and identified additional work
TR 21.910	Multi-mode UE issues; categories, principles and procedures

The concept of Multi Mode UEs was discussed, and proposals developed in other Working Groups were brought together and analysed in two Technical Reports.

Multi-mode User Equipments categories are identified. The TRs describe the consequences on roaming capabilities and service availability (e.g. handover) of such multi-mode UEs while roaming in various regions with various network configurations. This is achieved by means of case studies for each of the possible scenarios covered by existing specifications. In these studies care was taken that no duplication of text was made and that no inconsistencies were created between specifications.

7.1.7 QoS for Speech and Multimedia Codec

Acronym: QOS-SPEMC

References for WI "QoS for Speech and Multimedia Codec"

Document	Title/Contents
WIDs	
SA4_Work_Items_History	WI Sheet
SP-99060	WID WI S4-3: QoS for Speech and Multimedia Codec
Impacted Specifications	
	None
New Dedicated Specifications	
TR 26.912	QoS for Speech and Multimedia Codec; Quantitative performance evaluation of H.324 Annex C over 3G

The scope of this feature is to define the requirements on quality, bit rates, bit error rates, frame erasure rate, delay, etc. for speech and multimedia services.

Successful provision of speech and multimedia services in UMTS requires knowledge of the requirements that intended applications and codecs set for the PLMN (bearers, network architecture, etc.). The aim was to produce a Technical Report discussing the end-to-end quality of service (QoS) requirements and proposed solutions to provide adequate QoS for circuit switched and packet switched multimedia services within third generation mobile networks, and a Technical Specification for transmission planning aspects of speech (and multimedia) services on 3G networks, which was finally not completed and withdrawn of Release 99.

Changes to developing 3GPP specifications were felt possible depending upon the output of the study. In particular, the evaluation of requirements on quality, bitrates, bit error rates, frame erasure rate, delay etc. for speech and multimedia services were felt of relevance.

The output of the work item could be used by other 3GPP groups as guidance for setting requirements for satisfactory user-to-user service.

The technical requirements of speech and multimedia codecs outlined in the Technical Report should be satisfied by the related QoS parameters and other system implications, and by the speech and/or multimedia codec implementations in mobile terminals. The scope includes speech and multimedia services both in circuit switched and packet switched environments.

7.2 Feasibility Studies

- CAMEL control of Voice over Internet Protocol (VoIP) services
- Gateway Location Register (GLR) (appears in TS 23.002)
- Combined GSM and Mobile IP Mobility Handling in UMTS IP CN (WID in SMG 98/0760) (led to the incomplete TR 23.923)
- Study on provision of facsimile services in GSM and UMTS
- Turbo-Charger
NP-99457 contains the TR 23.913 V 1.0.0 on Turbo-charger presented to CN plenary for information and discussion only, since N1 did not agree to include the Turbo-charger for Release 99. It was later also deleted from Release 4 as a work item.

7.3 Other System Improvements

- Call Control improvements: These are minor improvements to 24.007 and to 24.008 with the intention of increasing the number of simultaneous calls/sessions from the present 7: the TI value is increased (NP-99441).
- Separation of Radio Resource and Mobility Management specific parts of the Mobile Station Classmark (TR 23.814). Clear separation of radio access network technology and core network technology was one prime requirement of UMTS, but also improvement of signalling efficiency. This concept enabled the system to be developed independently from other sub-system technologies.
- Idle mode classmark: The Non-Access-Stratum specification was separated out from TS 03.22 into TS 23.122. Procedures common to 2nd and 3rd generation core network aspects such as PLMN selection and location registration procedures are defined in 23.122, with 2nd generation specific issues remain in 03.22.

7.4 Features deleted or moved to later release

- Connecting an octet stream to a port on an Internet host

CN3 did some work on that (see IHOSS or OSP sections in 29.061). In the meantime again removed. It was part of the WI on Modem and ISDN interworking for GPRS that was deleted later on.

- Unstructured octet stream GPRS PDP Type

Same comment as for “Connecting an octet stream to a port on an Internet host”.

- GPRS - Point-To-Multipoint Services

It refers to the CN3 part of an overall function which was already cancelled in SA2.

- Modem and ISDN interworking for GPRS

It was deleted by SA#6 due to lack of requirements - old SMG 4 WI.

- UMTS Core based on ATM Transport

Not done.

- IP-in-IP tunnelling in GPRS backbone for UMTS, phase 1

Not done.

- Interworking with Mobile Satellite Systems

Nothing done at 3GPP.

- MS Antenna Test Method

Not done.

- L3 Segmentation

There are no CRs for R99, and the CN Plenary agreed to shift L3 segmentation to Rel-4 where it was later deleted as work item.

- Architecture for an All IP network

Lead to the incomplete TR 23.922

- Evolution of the GSM platform towards UMTS

Lead to TR 23.920 which has been partly reused for TS 23.101.

- Real time Fax

Moved to Rel 4.

- Provision of text telephony service in GSM and UMTS

Renamed to “Global Text Telephony”, which is a Release Independent Feature completed in Release 5 time frame.

- Support for real time services in the Packet domain for GSM/GPRS/UMTS R99

In Release 5.

- Tandem free operation (TFO) in 3G systems and between 2G and 3G systems

Moved to Rel-4 at the SA plenary in December 99

- Network Assisted Cell Change

Moved to Rel-4.

- Tandem Free Operation (TFO) of speech codecs in Mobile-to-Mobile Calls (MMCs) (GSM 10.53)

Also called “Tandem free operation (TFO) in 3G systems and between 2G and 3G systems”

Moved to Rel4.

- Out-of-Band Transcoder Control

Moved to Rel4.

- Fraud Information Gathering System applied to GPRS

This Feature is officially reported as belonging to Release 99 but was not produced for Release 99.

- Immediate Service Termination (IST) : CAMEL free solution

This Feature is officially reported as belonging to Release 99 but was not produced for Release 99.

- SS7 Security - Integrity checking

This Feature is officially reported as belonging to Release 99 but was not produced for Release 99 due to the limited timescale for introducing it into the Stage 3 specifications to meet the Release 99 deadline. It was intended to include MAC encryption for the most sensitive messages carried over SS7.

7.5 “Hollow” Features

These Features are officially reported as belonging to Release 99 but do not bring anything new (service, report, tool, etc) compared to earlier Release.

- High Speed Circuit Switched Data

There were no additional features for R99.

- CTS (Cordless Telephony System)

Work Item was mostly developed in 1999 (R98).

- SoLSA (Support of Localised Service Area)

Work Item part of release 1998. See 02.43 v 8.0.0 on “Support of Localised Service Area (SoLSA); Service description; Stage 1”.

This feature consists of a mechanism which can be used as a platform for providing special tariffs and/or special set of service features for certain subscribers within a regionally restricted area or areas.

There were no additional features for R99.

- Call Forwarding Enhancements (CFE) (CN4)

No enhancement on Call Forwarding has been identified for Release 99.

- Unstructured Supplementary Service Data (USSD) enhancements (CN4)

No enhancement on USSD has been identified for Release 99.

- LAPDm performance enhancement

No enhancement on LAPDm performance has been identified for Release 99.

- GSM-API for SIM-Toolkit

Work Item part of Release 1998.

- Display of Service Provider (SP) name by the Mobile Equipment (ME)

This functionality is already included in Releases earlier than Release 99.

7.6 Features for which there is no information, assumed to be abandoned and not implementable

- MS and Network-Resident Execution Environments (MS/N-RExE)
- Access to ISPs and Intranets in GPRS Phase 2 – Separation of GPRS Bearer Establishment and ISP Service Environment Setup
- Generic signalling mechanism for service support
- Impact of Telecommunications Data Protection Directive on GSM Standards (SMG01)
- Service to GSM Handportables in trains (SMG02)
- USIM/UICC Database. WID in TP-99210 stating:

“There is a requirement for operators to be able to use secure and complex data structures in the UICC/USIM which may be updated over the air.

This leads to the need for new functionality in the UICC/USIM to allow the storage and manipulation of complex data in the card in a more efficient way by means of a database.

This work item proposes the following scope of work:

- *Specification of access policy;*
- *Specification of internal interface for UICC applications;*
- *Specification of external interface (considering the use with both handset core software and MExE, but not including the definition of MExE commands);*
- *Specification of memory recovery requirements and processes;*
- *Specification of parameters and operations for data views manipulation;*
- *Investigation of over the air compatibility for downloading;*
- *Specification of synchronisation processes;*
- *Investigation into compression techniques;*
- *relationship between performance and structure of database;*
- *test scenarios.*

Additionally, as part of the scope, the use of database management for an evolution of the 3G phonebook feature should be investigated.”

- WAP WAE User Agent / SIM toolkit interworking