

### **Presentation of Specification to TSG**

---

<b>Presentation to:</b>	<b>TSG SA Meeting #23</b>
<b>Documents for presentation:</b>	<b>TS 33.221, Version 2.0.0</b>
<b>Presented for:</b>	<b>Approval</b>

---

#### **Abstract of document:**

In TSGS#22(03)0584, SA WG3 presented the status of the Support for Subscriber Certificates (SSC) TS 33.221 v100. At SA3#32, the TS was further progressed and is estimated to be complete to 90%. Hence some issues are left that need to be further elaborated, see below.

---

#### **Changes since last presentation to SA Meeting:**

- Applicability of other certificate profile specifications has been clarified.
  - The content-type for the certificate chain delivery has been selected.
  - The possible service discovery of PKI portal is addressed in the TS.
- 

#### **Outstanding Issues:**

- The charging mechanism and whether it needs to be standardized in 3GPP is FFS.
  - The usage of shared key TLS instead of HTTP Digest as a method for securing enrolment is FFS. Currently, HTTP Digest is used to secure the enrolment.
- 

#### **Contentious Issues:**

None.

# 3GPP TS 33.221 V1.2.01 (2004-023)

*Technical Specification*

## **3rd Generation Partnership Project; Technical Specification Group Services and System Aspects; Generic Authentication Architecture (GAA); Support for Subscriber Certificates (Release 6)**



The present document has been developed within the 3<sup>rd</sup> Generation Partnership Project (3GPP<sup>TM</sup>) and may be further elaborated for the purposes of 3GPP.

The present document has not been subject to any approval process by the 3GPP Organizational Partners and shall not be implemented. This Specification is provided for future development work within 3GPP only. The Organizational Partners accept no liability for any use of this Specification. Specifications and reports for implementation of the 3GPP<sup>TM</sup> system should be obtained via the 3GPP Organizational Partners' Publications Offices.

Keywords

---

Security, GAA, Subscriber certificates

**3GPP**

Postal address

---

3GPP support office address

---

650 Route des Lucioles - Sophia Antipolis  
Valbonne - FRANCE  
Tel.: +33 4 92 94 42 00 Fax: +33 4 93 65 47 16

Internet

---

<http://www.3gpp.org>

---

**Copyright Notification**

---

No part may be reproduced except as authorized by written permission.  
The copyright and the foregoing restriction extend to reproduction in all media.

© 2003, 3GPP Organizational Partners (ARIB, CCSA, ETSI, T1, TTA, TTC).  
All rights reserved.

# Contents

Foreword.....	6
1 Scope .....	7
2 References .....	7
3 Definitions and abbreviations .....	8
3.1 Definitions.....	8
3.2 Abbreviations .....	8
4 Support for Subscriber Certificates .....	9
4.1 Introduction.....	9
4.2 Reference model.....	9
4.3 Network elements.....	10
4.3.1 PKI Portal .....	10
4.3.2 Bootstrapping Server Function .....	10
4.3.3 User Equipment .....	10
4.4 Requirements and principles for issuing subscriber certificates.....	10
4.4.1 Usage of Bootstrapping .....	10
4.4.2 Access independence .....	10
4.4.3 Roaming and service network support.....	10
4.4.4 Home operator control.....	11
4.4.5 Charging principles .....	11
4.4.6 Subscriber Certificate Profile .....	11
4.4.7 Service Discovery.....	11
4.4.8 Requirements on Ua interface .....	12
4.5 Certificate issuing architecture.....	12
4.5.1 Ua interface .....	12
4.5.1.1 General description.....	12
4.5.1.2 Functionality and protocols .....	13
4.5.1.2.1 PKCS#10 with HTTP Digest Authentication.....	13
4.5.1.2.2 Key Generation .....	13
4.6 Certificate issuing procedure.....	14
4.6.1 Certificate issuing.....	15
4.6.2 CA Certificate delivery.....	18
4.7 Functionality in presence of pre-certified key pair or pre-shared keys .....	20
4.7.1 Presence of pre-certified key pair .....	20
4.7.2 Presence of symmetric pre-shared key .....	21
<b>Annex A (informative): Key pair storage .....</b>	<b>22</b>
A.1 Introduction .....	22
A.2 Key pair storage use-cases.....	22
A.2.1 Key pair storage on the ME.....	22
A.2.2 Key pair storage on the UICC .....	22
A.3 Threats associated with the key pair.....	22
A.3.1 Key pair generation .....	22
A.3.2 Unauthorized usage of the private key .....	22
A.3.3 Portability .....	23
A.3.4 Environment .....	23
A.3.5 Threat to the required properties for digital signatures.....	23
A.4 Security risk analysis related to key pair storage.....	24
A.4.1 Subscriber certificate use-cases .....	24
A.4.1.1 Secure services .....	24
A.4.1.2 Secure connectivity .....	24
A.4.2 Security risk analysis in some scenarios.....	24
A.4.2.1 Scenarios involving subscriber's personal data.....	25

A.4.2.1.1	Self-service management .....	25	
A.4.2.1.2	Security Risk Analysis in this scenario .....	25	
A.4.2.2	Scenarios involving payment and agreement between operator and service provider .....	26	
A.4.2.2.1	Notifications through cellular network scenario .....	26	
A.4.2.2.2	Small to medium payment through cellular operator scenario .....	26	
A.4.2.2.3	Security Risk Analysis in these scenarios .....	27	
A.4.3	Summary of risk analysis .....	28	
<b>Annex B (informative): Change history .....</b>		<b>29</b>	
Foreword .....			5
1	Scope .....	6	
2	References .....	6	
3	Definitions and abbreviations .....	7	
3.1	Definitions .....	7	
3.2	Abbreviations .....	7	
4	Support for Subscriber Certificates .....	8	
4.1	Introduction .....	8	
4.2	Reference model .....	8	
4.3	Network elements .....	9	
4.3.1	PKI Portal .....	9	
4.3.2	Bootstrapping Server Function .....	9	
4.3.3	User Equipment .....	9	
4.4	Requirements and principles for issuing subscriber certificates .....	9	
4.4.1	Usage of Bootstrapping .....	9	
4.4.2	Access independence .....	9	
4.4.3	Roaming and service network support .....	9	
4.4.4	Home operator control .....	10	
4.4.5	Charging principles .....	10	
4.4.6	Subscriber Certificate Profile .....	10	
4.4.7	Service Discovery .....	10	
4.4.8	Requirements on Ua interface .....	11	
4.5	Certificate issuing architecture .....	11	
4.5.1	Ua interface .....	11	
4.5.1.1	General description .....	11	
4.5.1.2	Functionality and protocols .....	12	
4.5.1.2.1	PKCS#10 with HTTP Digest Authentication .....	12	
4.5.1.2.2	Key Generation .....	12	
4.6	Certificate issuing procedure .....	13	
4.6.1	Certificate issuing .....	14	
4.6.2	CA Certificate delivery .....	16	
4.7	Functionality in presence of pre-certified key pair or pre-shared keys .....	17	
4.7.1	Presence of pre-certified key pair .....	17	
4.7.2	Presence of symmetric pre-shared key .....	18	
<b>Annex A (informative): Key pair storage .....</b>		<b>19</b>	
A.1	Introduction .....	19	
A.2	Key pair storage use cases .....	19	
A.2.1	Key pair storage on the ME .....	19	
A.2.2	Key pair storage on the UICC .....	19	

<u>A.3</u>	<u>Threats associated with the key pair</u>	<u>19</u>
<u>A.3.1</u>	<u>Key pair generation</u>	<u>19</u>
<u>A.3.2</u>	<u>Unauthorized usage of the private key</u>	<u>19</u>
<u>A.3.3</u>	<u>Portability</u>	<u>20</u>
<u>A.3.4</u>	<u>Environment</u>	<u>20</u>
<u>A.3.5</u>	<u>Threat to the required properties for digital signatures</u>	<u>20</u>
<u>A.4</u>	<u>Security risk analysis related to key pair storage</u>	<u>21</u>
<u>A.4.1</u>	<u>Subscriber certificate use cases</u>	<u>21</u>
<u>A.4.1.1</u>	<u>Secure services</u>	<u>21</u>
<u>A.4.1.2</u>	<u>Secure connectivity</u>	<u>21</u>
<u>A.4.2</u>	<u>Security risk analysis in some scenarios</u>	<u>21</u>
<u>A.4.2.1</u>	<u>Scenarios involving subscriber's personal data</u>	<u>22</u>
<u>A.4.2.1.1</u>	<u>Self service management</u>	<u>22</u>
<u>A.4.2.1.2</u>	<u>Security Risk Analysis in this scenario</u>	<u>22</u>
<u>A.4.2.2</u>	<u>Scenarios involving payment and agreement between operator and service provider</u>	<u>23</u>
<u>A.4.2.2.1</u>	<u>Notifications through cellular network scenario</u>	<u>23</u>
<u>A.4.2.2.2</u>	<u>Small to medium payment through cellular operator scenario</u>	<u>23</u>
<u>A.4.2.2.3</u>	<u>Security Risk Analysis in these scenarios</u>	<u>24</u>
<u>A.4.3</u>	<u>Summary of risk analysis</u>	<u>25</u>
<b><u>Annex B (informative): Change history</u></b>		<b><u>26</u></b>

---

# Foreword

This Technical Specification has been produced by the 3<sup>rd</sup> Generation Partnership Project (3GPP).

The contents of the present document are subject to continuing work within the TSG and may change following formal TSG approval. Should the TSG modify the contents of the present document, it will be re-released by the TSG with an identifying change of release date and an increase in version number as follows:

Version x.y.z

where:

- x the first digit:
  - 1 presented to TSG for information;
  - 2 presented to TSG for approval;
  - 3 or greater indicates TSG approved document under change control.
- y the second digit is incremented for all changes of substance, i.e. technical enhancements, corrections, updates, etc.
- z the third digit is incremented when editorial only changes have been incorporated in the document.

---

# 1 Scope

The present document describes subscriber certificate distribution by means of generic bootstrapping architecture (GBA) [11]. Subscriber certificates support services whose provision the mobile operator assists, as well as services that are offered by the mobile operator.

The scope of this specification presents signalling procedures for support of issuing certificates to subscribers and the standard format of certificates and digital signatures. It is not intended to duplicate existing standards being developed by other groups on these topics, and will reference these where appropriate.

**Editor's note:** The specification objects are scheduled currently in phases. For the first phase of standardisation, only the case is considered where bootstrapping server functionality and network application function are located in the same network as the HSS. In later phases, other configurations may be considered.

---

# 2 References

The following documents contain provisions which, through reference in this text, constitute provisions of the present document.

- References are either specific (identified by date of publication, edition number, version number, etc.) or non-specific.
- For a specific reference, subsequent revisions do not apply.
- For a non-specific reference, the latest version applies. In the case of a reference to a 3GPP document (including a GSM document), a non-specific reference implicitly refers to the latest version of that document *in the same Release as the present document*.

- [1] PKCS#10 v1.7: "Certification Request Syntax Standard", RSA Laboratories, May 2000.
- [2] Adams C., Farrell S.: "Internet X.509 Public Key Infrastructure Certificate Management Protocols", RFC 2510, March 1999.
- [3] Myers M., et al.: "Internet X.509 Certificate Request Message Format", RFC 2511, March 1999.
- [4] Chokhani S., et al.: "Internet X.509 Public Key Infrastructure Certificate Policy and Certification Practices Framework", RFC 2527, March 1999.
- [5] Franks J., et al.: "HTTP Authentication: Basic and Digest Access Authentication", RFC 2617, June 1999.
- [6] Housley R., et al.: "Internet X.509 Public Key Infrastructure Certificate and Certificate Revocation List (CRL) Profile", RFC 3280, April 2002.
- [7] WAP-211-WAPCert, 22.5.2001: <http://www1.wapforum.org/tech/terms.asp?doc=WAP-211-WAPCert-20010522-a.pdf>
- [8] WAP-260-WIM-20010712, 12.7.2001: <http://www1.wapforum.org/tech/documents/WAP-260-WIM-20010712-a.pdf>
- [9] WAP-217-WPKI, 24.4.2001: <http://www1.wapforum.org/tech/documents/WAP-217-WPKI-20010424-a.pdf>
- [10] ITU-T Recommendation X.509 (1997) | ISO/IEC 9594-8:1997: "Information Technology - Open Systems Interconnection - The Directory: Authentication Framework", 1997.
- [11] 3GPP TS 33.220: "3rd Generation Partnership Project; Technical Specification Group Services and System Aspects; Generic Authentication Architecture (GAA); Generic Bootstrapping Architecture".



- [12] 3GPP TS 33.222: "3rd Generation Partnership Project; Technical Specification Group Services and System Aspects; Generic Authentication Architecture (GAA); Access to Network Application Function using HTTPS".
- [13] 3GPP TR 33.919: "3rd Generation Partnership Project; Technical Specification Group Services and System Aspects; Generic Authentication Architecture (GAA); System description".
- [14] Open Mobile Alliance ECMA Crypto Library <http://www.openmobilealliance.org>.
- [15] Blake-Wilson, S., et al, "Transport Layer Security (TLS) Extensions", RFC 3546, June 2003.
- [16] Directive 1999/93/EC of the European Parliament and of the Council of 13 December 1999 on a Community framework for electronic signatures.
- [17] Santesson, S., Polk, W., Barzin, P., and M. Nystrom, "Internet X.509 Public Key Infrastructure Qualified Certificates Profile", RFC 3039, January 2001.
- [18] ETSI TS 101 862: "Qualified certificate profile".
- [19] OMA: "Provisioning Content Version 1.1", Version 13-Aug-2003. Open Mobile Alliance.

---

## 3 Definitions and abbreviations

### 3.1 Definitions

For the purposes of the present document, the following terms and definitions apply.

**Subscriber certificate:** a certificate issued to a subscriber. It contains the subscriber's own public key and possibly other information such as the subscriber's identity in some form.

**CA certificate:** A Certificate Authority signs all certificates that it issues with its private key. The corresponding Certificate Authority public key is itself contained within a certificate, called a CA Certificate.

### 3.2 Abbreviations

For the purposes of the present document, the following abbreviations apply:

AK	Anonymity Key
AKA	Authentication and Key Agreement
BSF	Bootstrapping Server Function
CA	Certificate Authority
CMP	Certificate Management Protocols
GAA	Generic Authentication Architecture
GBA	Generic Bootstrapping Architecture
HSS	Home Subscriber System
IK	Integrity Key
MNO	Mobile Network Operator
NAF	Network Application Function
PKCS	Public-Key Cryptography Standards
PKI	Public Key Infrastructure
UE	User Equipment

## 4 Support for Subscriber Certificates

### 4.1 Introduction

Digital signatures can be used, for instance, to secure mobile commerce, service authorization and accounting. But digital signature by itself is not enough; there is need of a global support for authorization and charging. This TS specifies a global and secure authorization and charging infrastructure of mobile networks to support a local architecture for digital signatures.

Subscriber certificates, issued using the mechanisms described in this TS, provide a migration path towards global Public Key Infrastructure (PKI). A local architecture for digital signatures can be deployed incrementally; one operator can choose to deploy independently of the others. On the other hand, the existence of subscribers and service providers that use digital signatures makes it easier to build a global PKI.

3GPP systems shall issue subscriber certificates in order to authorize and account for service usage both in home and in visited networks. This requires specification of:

1. procedures to issue temporary or long-term certificates to subscribers;
2. standard format of certificates and digital signatures, e.g. re-using OMA wireless PKI specifications.

The mechanism shall allow a cost efficient implementation of the security support of the UE. It will also enable a user's anonymity towards the service provider, whilst the user who invokes the service, can be identified by the network.

Open Mobile Alliance offers an alternative solution for certificate enrolment (c.f. subclause 4.5)

Subscriber certificates support services whose provision the mobile operator assists, as well as services that the mobile operator provides. There is no need to standardize those services in this TS. Also, the communication between service provider and the operator (in the role of certificate issuer) need not be standardized in this TS.

### 4.2 Reference model

Figure 1 shows a simple network model of the entities involved in the certificate issuing, and the interfaces used between the network entities.

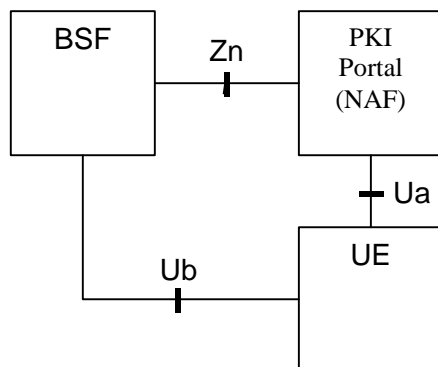

Figure 1: Simple network model for certificate issuing

## 4.3 Network elements

### 4.3.1 PKI Portal

A PKI Portal shall issue a certificate for UE and deliver an operator CA certificate. In both cases, requests and responses are protected by shared key material that has been previously established between UE and a BSF

In PKI terms, the PKI portal is a Registration Authority (RA) who authenticates the certification request based on cellular subscription. PKI Portal may also function as a Certification Authority (CA) who issues certificates. However, this task may also be done in an existing PKI infrastructure towards which the PKI Portal would function as a RA only, and the CA would be in the PKI infrastructure.

### 4.3.2 Bootstrapping Server Function

The bootstrapping server function (BSF) shall support the PKI portal by providing the authentication (c.f. subclause 4.2.2.1) and subscriber profile information (i.e., whether subscriber is able to enrol a certain types of subscriber certificate).

### 4.3.3 User Equipment

The required new functionality from UE is the support of the Ua interface (i.e. certification enrolment protocol) that is protected using the shared keys established during bootstrapping function.

In addition UE may have the capability to generate public and private key pairs, store the private key part to a non-volatile memory (e.g., in UICC), and protect the usage of the private key part (e.g., with a PIN).

## 4.4 Requirements and principles for issuing subscriber certificates

The following prerequisites for issuing of subscriber certificates exist:

- the UE and the mobile operator's PKI portal share key material to support the certificate request and operator CA certificate retrieval;
- the issuing of the requested certificate is allowed according to the subscriber's profile. The PKI portal is responsible for performing this check before issuing the subscriber certificate;
- in the case that the private key is stored on a WIM [8], which is capable of providing a proof of key origin (assurance info that the key is securely stored in a tamper-resistant device), it shall be possible to send this information with the certificate request.

NOTE: Procedures for providing proof of key origin are not limited to the WIM application.

### 4.4.1 Usage of Bootstrapping

Issuing procedures of the subscriber certificate and operator CA certificate shall be secured by using shared keys obtained from the 3GPP generic bootstrapping architecture as specified in TS 33.220 [11].

### 4.4.2 Access independence

Subscriber certificate and operator CA certificate issuing procedures are access independent. Certificate issuing procedures require IP connectivity from the UE.

### 4.4.3 Roaming and service network support

The roaming subscriber shall be able to request subscriber certificates and operator CA certificates from the home network.

Editor's note: Certificate requests to any than home network may be supported in later phase of the present specification.

#### 4.4.4 Home operator control

Home operator shall be able to control the issuing of subscriber certificates. The control includes to whom the certificates are allowed to issue and the types of issued certificates.

Operator control is supported by information in the subscriber profile. For each type of subscriber certificate, i.e. for different keyUsage in WAP Certificate and CRL Profile, subscriber profile shall contain a flag that allows or disallows the issuing of that type of certificate to subscriber.

Editor's note: Currently two keyUsage values are envisioned: authentication and signing.

Delivery of operator CA certificates is always allowed.

Editor's note: For the first phase of standardisation, only the case is considered where bootstrapping server functionality and network application function are located in the same network as the HSS. Thus is the first phase the home network control does not require any communication between home and visited networks. In later phases, when also visited network may issue certificates, standardized way of transferring the control information from home network to visited network is needed.

#### 4.4.5 Charging principles

The operator shall be capable to charge issuing of subscriber certificates or delivery of operator CA certificates.

Editor's note: The charging mechanism and whether it needs to be standardized in 3GPP is FFS.

#### 4.4.6 Subscriber Certificate Profile

Subscriber certificate profile shall be based on WAP Certificate and CRL Profile [7], which in turn is based on profiles defined in [6] and [10]. A certificate profile defines the format and semantics of certificates in a specific context. WAP Certificate and CRL profiles specification defines four certificate profiles: two user certificate profiles – one for authentication and the other for non-repudiation purposes, server certificate profile for authentication, and authorization certificate profile (i.e., CA certificate). Since subscriber certificates are issued to users, and since services need CA certificate to validate subscriber certificates, the relevant WAP certificate profiles to be used with subscriber certificate profiles are the user certificate profiles, and CA certificate profile.

IETF's and ETSI's Qualified certificate profiles [17,18] may also be used as the subscriber certificate profile if the certification practices followed by the certificate issuing operator fulfil all of the requirements stated in [16,17,18].

The following certificate extensions may be filled with the information given by the UE in the certification request:

- Intended certificate usage (i.e., using keyUsage and/or extKeyUsage extensions [7]).
- Subscriber identities (i.e., subject name field, and possible additional identities defined in the subjectAltName extension [7]). Operator CA shall authorize each suggested subscriber identity.
- Proof of key origin (i.e., keyGenAssertion). Operator CA shall verify the proof of key origin if it is presented.

NOTE: It is not mandatory for Operator CA to insert these suggested extensions by UE to the certificate. Rather, Operator CA shall issue certificates based on its certification policies. It may write a certification practice statement (CPS) [4], where it describes the general requirements and steps taken during the certificate issuing.

#### 4.4.7 Service Discovery

To enable the certificate enrollment procedure, the addresses of bootstrapping server and PKI portal should be configured to the UE. The BSF discovery method is specified in [11].

**Editor's note:** For the first phase of standardisation, when bootstrapping server functionality and network application function are always located in home network, therefore pre-configuration of addresses may be sufficient. In later phases, however, when UE needs to address of PKI Portal in the visited network, more flexible is needed in the solution.

A procedure needs to be described on how to discover the location of PKI portal. It shall be possible to enable the UE to be configured either manually or automatically via one of the following approaches:

- The address information shall be published via reliable channel. Subscribers shall store all the parameters as part of the establishment of IP connectivity. The address information needs to be input only once.
- The address information shall be pushed automatically to the UE over the air when the subscription to bootstrapping service is accepted. All the parameters shall be saved into the UE and used in the same manner as above. The procedure is specified in [19].

## 4.4.8 Requirements on Ua interface

The requirements for Ua interface are:

- UE shall be able to request for subscriber's certification from the PKI portal that plays the role of the NAF over a network connection;
- NAF shall be able to authenticate UE's certificate request;
- UE shall be able to acquire an operator's CA certificate over the network connection;
- UE shall be able to authenticate the NAF response (i.e., operator CA certificate delivery);
- the procedure shall be independent of the access network used;
- the NAF shall have access to the subscriber profile to check the certification policies. This means that the Zn interface [11] shall support for retrieving a subset of the subscriber profile;
- the response and delivery of certificate to UE shall be within a few seconds after the initial certification request;
- certification request format shall be PKCS#10;
- certification response format shall be one of the following: a certificate, a pointer to the certificate, or a full certificate chain.

## 4.5 Certificate issuing architecture

### 4.5.1 Ua interface

#### 4.5.1.1 General description

In the certificate issuing, Ua interface is used to for:

- The operator CA certifying subscriber's public keys in format of certificates; and
- The delivery of the Operator CA certificate to the UE.

During subscriber certificate issuing, UE may request a certification of a public key. The supported request format shall be PKCS#10. It is used to encapsulate the public key and other attributes (i.e., subject name, intended key usage, etc.). The request is transported from the UE to the PKI Portal over Ua interface. Upon receiving the certification request, the PKI portal will certify the public key according to its own certification practice policies and subscriber profile which is fetched through BSF from HSS. If PKI Portal decides to certify the public key, it will digitally sign it, and generate the corresponding certificate, which is returned from PKI Portal to the UE, over Ua interface.

During operator CA certificate delivery, the UE may request the PKI Portal to deliver operator CA's certificate. In the corresponding response, the PKI Portal will deliver the CA's certificate to the UE. Since the operator's CA certificate is typically a self-signed certificate and the validation of certificates signed by this CA is based on this particular CA certificate, it needs to be delivered over authenticated and secured channel.

Authentication, integrity protection, and possibly encryption of the messages sent over Ua interface are based on the BSF generated shared secret according to the GBA in TS 33.220 [11], where the PKI portal acts as a Network Application Function (NAF).

#### 4.5.1.2 Functionality and protocols

##### 4.5.1.2.1 PKCS#10 with HTTP Digest Authentication

**Editor's note:** This section uses HTTP Digest authentication to authenticate and integrity protect the certificate request and response. Shared key TLS is another solution to authenticate and protect the certificate enrolment, and whether it should be used instead of HTTP Digest is ffs. This section also needs to be aligned with annex A of the GBA TS.

HTTP Digest Authentication scheme [5] may be done with BSF shared key material the following way:

- UE makes a blank HTTP request to the NAF;
- NAF returns a HTTP response with "WWW-Authenticate" header indicating that HTTP Digest Authentication is needed. Quality of protection (qop) attribute is set to "auth-int" meaning that the content in following HTTP requests and responses are integrity protected;
- UE calculates the correct response to the "WWW-Authenticate" header using the *identifier* (base64 encoded) as the username and the session key Ks (base64 encoded) as the password. The session key Ks is has been previously derived from the key material Ks that resulted from using Ub interface. HTTP Digest Authentication parameters are returned in the "Authorization" header of HTTP Response;
- NAF validates the "Authorization" header and upon successful validation, performs the requested task. In the corresponding HTTP response, NAF calculates the relevant values for "Authentication-Info" header, which is used to authenticate and integrity protect the NAF response;
- UE validates the "Authentication-Info" header and upon successful validation, accepts the payload in the HTTP response.

A PKCS#10 [1] based certification request is sent to the CA NAF using a HTTP POST request, which shall be authenticated and integrity protected by HTTP Digest Authentication.

Certificate is delivered using the HTTP response, which may be authenticated and integrity protected by HTTP Digest Authentication. The content-type of the HTTP response depends on the response format. If a certificate is returned then it is "application/x-x509-user-cert". If a pointer to the certificate is returned then it is "application/vnd.wap.cert-response" as specified in [9]. If a certificate chain is returned, then it is "application/pkix-path" as specified in [15].

The UE requests a CA certificate delivery by sending a plain HTTP GET request with specific parameters in the request URI. The request may be authenticated and integrity protected by HTTP Digest Authentication.

CA certificate is delivered using the HTTP response, which shall be authenticated and integrity protected by HTTP Digest Authentication. The content-type of the HTTP response would be "application/x-x509-ca-cert". Note that the user should always be notified when a new CA certificate is taken into use.

##### 4.5.1.2.2 Key Generation

If the private key is stored in a UICC (e.g. in a WIM) and the UICC demands a special authorization (e.g. from the Operator) to generate the key, the ME may need to perform an HTTP POST request, which MAY be authenticated and integrity protected by HTTP Digest Authentication, to the NAF in order to deliver a nonce that is generated by the UICC. This will allow the NAF to authenticate directly to the UICC application and provide authorization for the key generation.

**Editor's note:** A reference to the relevant OMA specifications should be added.

## 4.6 Certificate issuing procedure

Editor's note: This section uses HTTP Digest authentication to authenticate and integrity protect the certificate request and response. Shared key TLS is another solution to authenticate and protect the certificate enrolment, and whether it should be used instead of HTTP Digest is ffs. This section also needs to be aligned with annex A of the GBA TS.

### 4.6.1 Certificate issuing

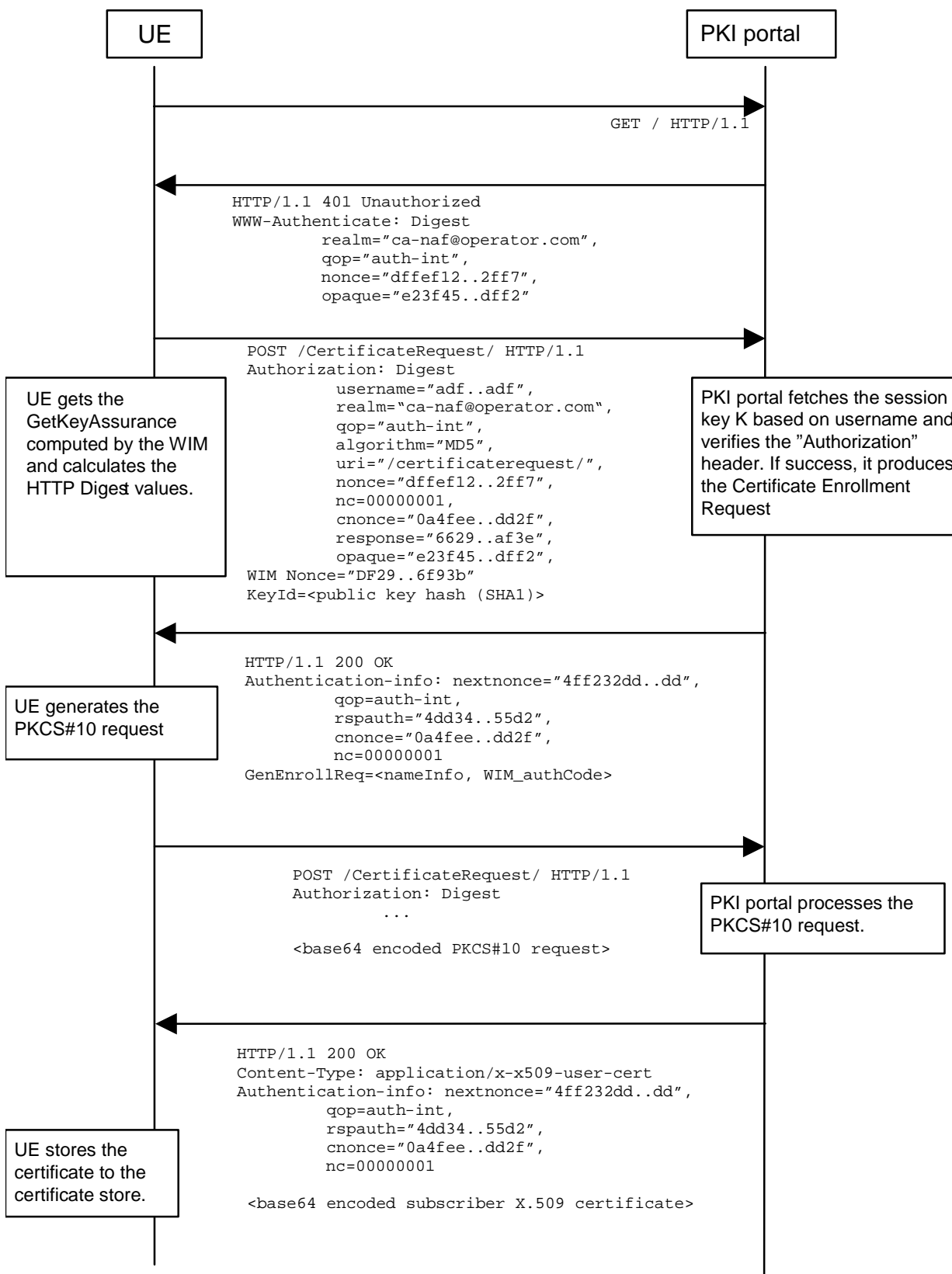

**Figure 2: Certificate request using PKCS#10 with HTTP Digest Authentication**

The sequence diagram above describes the certificate request when using PKCS#10 with HTTP Digest. The sequence starts with an empty HTTP request to PKI portal. The PKI portal responds with HTTP response code 401



"Unauthorized" which contains a WWW-Authenticate header. The header instructs the UE to use HTTP Digest authentication.

The UE will generate the HTTP request by calculating the Authorization header values using the Transaction Identifier it received from the BSF as username and the session key Ks. If the certificate request needs extra assurance by a WIM application for key Proof of Origin, the UE should include a WIM Nonce and the key id (i.e. SHA-1 public key hash) in this request

When PKI portal, acting as an NAF, receives the request, it will verify the Authorization header by fetching the session key Ks from the bootstrapping server using the identifier, then calculating the corresponding digest values using Ks, and finally comparing the calculated values with the received values in the Authorization header. If the verification succeeds, the PKI portal may use the subscriber profile to compute and send back a GenEnrollReq attribute containing additional parameters that are needed for the following PKCS#10 request generation (e.g. nameInfo, WIM\_authCode, ...). The PKI portal may use session key Ks to integrity protect and authenticate this response.

The UE will then generate the PKCS#10 request and send it to the CA NAF by using an HTTP Digest request. In the case that the private key is stored in a WIM application the ME should request the AssuranceInfo from the WIM application and include it in the PKCS#10 request, if provided. The enrolment request will follow the PKCS #10 certificate enrollment format as defined in [1]. Adding AssuranceInfo in this request is defined in the OMA ECMA Script GenEnrollReq specification [14]. The AssuranceInfo provides a proof of origin for the key processing (e.g. identifies the WIM application and provides a proof that the key is stored in it). UE may indicate the desired format of the certification response: a certificate, a pointer to the certificate (e.g., URL), or a full certificate chain (i.e., from the issued certificate to the corresponding root certificate). The enrolment request shall be as follows:

```
POST <base URL>?response=<indication>[other URL parameters] HTTP/1.1
Content-Type: application/x-pkcs10
```

```
<base64 encoded PKCS#10 blob>
```

where:

<base URL> identifies a server/program.

<indication> used to indicate to the CA NAF what is desired response type for the UE. The possible values are: "single" for subscriber certificate only, "pointer" for pointer to the subscriber certificate, or "chain" for full certificate chain.

[other URL parameters] are additional, optional, URL parameters.

The incoming PKCS#10 request is taken in for further processing. If the CA NAF is actually a registration authority (RA NAF), the PKCS#10 request is forwarded to CA using any protocol available (e.g., CMC or CMP). After the PKCS#10 request has been processed and a certificate has been created, the new certificate is returned to the CA NAF. It will generate a HTTP response containing the certificate, or the pointer to the certificate as defined subclause 7.4 of [9], or a full certificate chain from issued certificate to the root certificate.

If the HTTP response contains the subscriber certificate itself, it shall be base64 encoded, and it may be demarcated as follows:

```
HTTP/1.1 200 OK
Content-Type: application/x-x509-user-cert
```

```
-----BEGIN CERTIFICATE-----
<base64 encoded X.509 certificate blob>
-----END CERTIFICATE-----
```

If the HTTP response contains the pointer to the certificate, the CertResponse structure defined in subclause 7.3.5 of the OMA WPKI [9] shall be used, and it may be demarcated as follows:

```
HTTP/1.1 200 OK
Content-Type: application/vnd.wap.cert-response
```

```
-----BEGIN CERTIFICATE RESPONSE-----
<base64 encoded CertResponse structure blob>
-----END CERTIFICATE RESPONSE-----
```

If the HTTP response contains a full certificate chain in PkiPath structure as defined in [15] and it shall be base64 encoded:

```
HTTP/1.1 200 OK
Content-Type: application/pkix-path

<base64 encoded PkiPath blob>
```

The content-type header value for the certificate chain is "application/pkix-path" as specified in [15].

The PKI portal may use session key  $K_s$  to integrity protect and authenticate the response, if a certificate or a pointer to the certificate is sent to the UE. The PKI portal shall use integrity protection and authenticate the response if full certificate chain is sent to the UE.

When UE receives the subscriber certificate, it is stored to local certificate management system.

NOTE: On board key generation is already defined in the WIM specification [8] issued by Open Mobile Alliance (OMA) group.

## 4.6.2 CA Certificate delivery

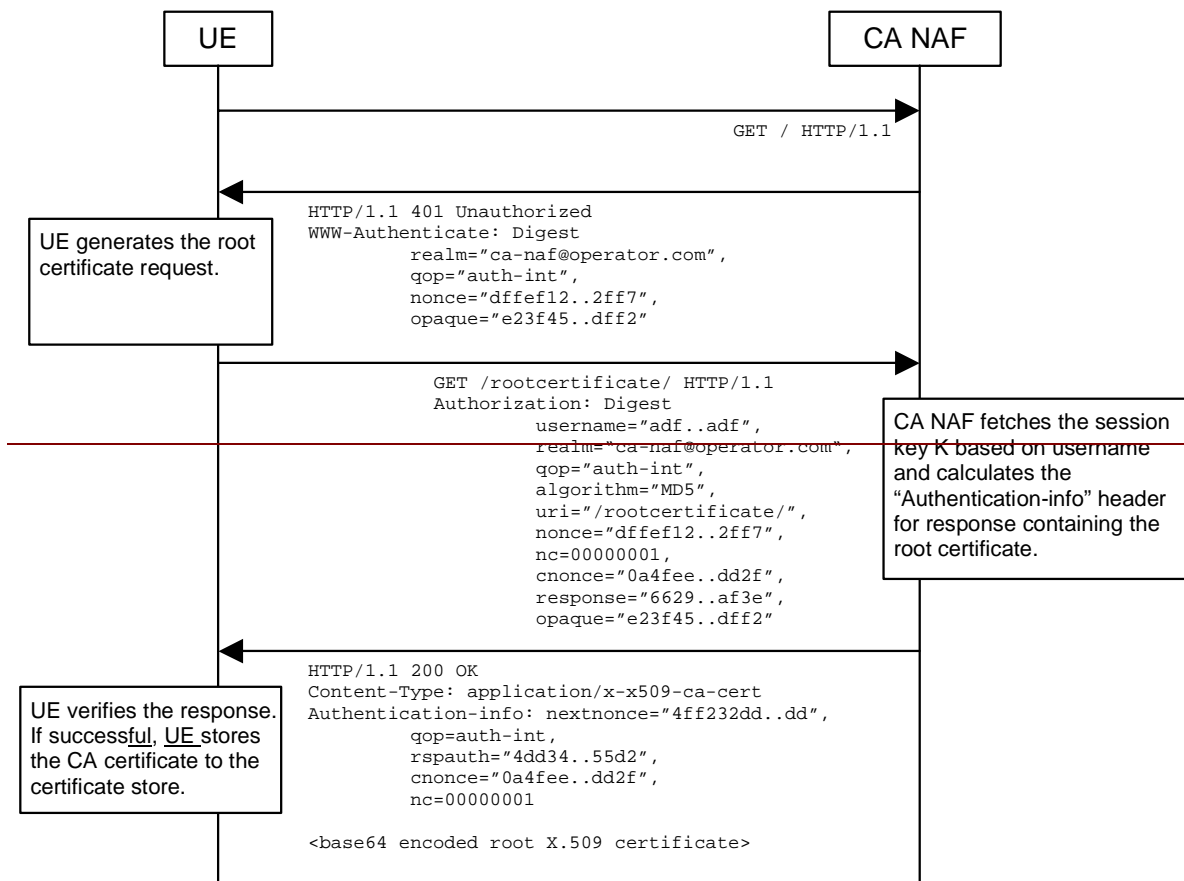
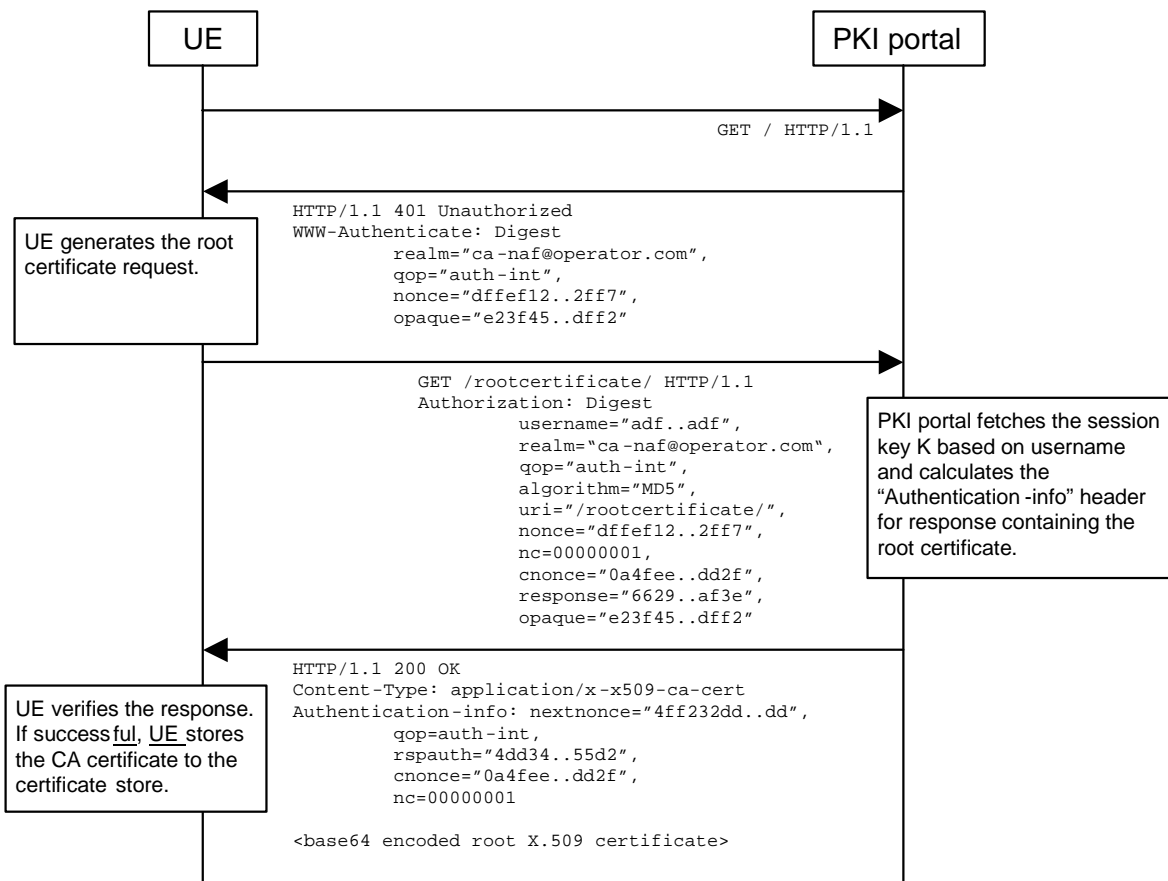

### Figure 3: CA certificate delivery with HTTP Digest authentication

The sequence diagram above describes the CA certificate delivery when using HTTP Digest authentication. The sequence starts with an empty HTTP request to CA NAF. The CA NAF responds with HTTP response code 401 "Unauthorized" which contains a WWW-Authenticate header. The header instructs the UE to use HTTP Digest for authentication.

The UE generates another HTTP request for requesting the CA certificate. UE shall indicate the CA issuer name in the request URL as specified in subclause 7.4.1 of [9]. The serial number field shall be omitted. The Authorization header values are calculated using the identifier and the session key Ks. The authentication of this HTTP request is not necessary, but it is done in order to follow HTTP Digest authentication specification. Also, the identifier needs to be transported to the CA, i.e. the NAF. A request of subscriber's certificate is specified in subclause 4.4.1.1. The CA certificate delivery request shall be as follows:

```
GET <base URL>?in=<issuer name>[other URL parameters] HTTP/1.1
```

where

<base URL> identifies a server/program.  
 <issuer name> identifies the certificate issuer. It is a base64 encoding of the DER encoded Issuer field in the X.509 certificate.  
 [other URL parameters] are additional, optional, URL parameters.

When CA NAF receives the request, it may verify the Authorization header by fetching the session key Ks from the bootstrapping server using the identifier. CA NAF will generate a HTTP response containing the CA certificate and use the session key Ks to authenticate and integrity protect the HTTP response using the Authentication-info header. Essentially, the response could also be other delivery protocol in HTTP format, e.g. PKCS#7 cryptographic message with content type signedData.

HTTP response contains the CA certificate. The CA certificate shall be base64 encoded, and it may be demarcated as follows:

```
HTTP/1.1 200 OK
Content-Type: application/x-x509-ca-cert

-----BEGIN CERTIFICATE-----
<base64 encoded X.509 certificate blob>
-----END CERTIFICATE-----
```

When UE receives the new CA certificate, it must validate the Authentication-info header. If validation succeeds, the user is notified that a new CA certificate is taken into use. If user accepts the new CA certificate, it is stored to the local certificate management system and marked as "trusted" CA certificate.

## 4.7 Functionality in presence of pre-certified key pair or pre-shared keys

*Editor's note: Based on contribution S3-030037, it was agreed to add this part into the present document for ffs.*

### 4.7.1 Presence of pre-certified key pair

An alternative to securing certificate enrolment based on AKA and bootstrapping function is to secure certificate enrolment based on signatures made with pre-certified key in the UE. This alternative has been specified by Open Mobile Alliance (see section 7.3.4 of [9]) and is thus out of scope of this specification. The functionality in presence of pre-certified key pair in the UE is explained below only briefly.

In this alternative solution, the UE equipped with a UICC, is previously issued with a pre-loaded, long lasting, public/private key pair from the home network. This phase would occur out of band, and would result in the UE possessing a long lasting key pair stored in the UICC for the purposes of certificate request authentication. Open Mobile Alliance (OMA) group offers standardized solutions by means of WPKI specification [9] and WIM specification [8] for the storage and the use of long-lasting key pair. USIM and WIM are examples of applications on the UICC that can deal with the long-lasting keys.

The UE can issue a request for a certificate to the CA, including a proof of origin (e.g. private key is stored in WIM) by using an administrative long lasting private key. The certificate request itself could contain a newly generated public key that is to be certified by the CA. This assumes that the new key pair is generated in the UICC. Access control security for the pre-loaded long-lasting private key should be at least as good as for access control for USIM.

The certificate for the administrative long lasting private key, that provides the proof of generated key origin, is always long lasting certificate. On the other hand the generated user keys in the WIM may have short or long-lived certificate depending on CA policies (see [8], [9], [14]).

## 4.7.2 Presence of symmetric pre-shared key

Same as above but the administrative key that provides the proof of generated key origin is a shared symmetric key, in which case it does not have a certificate (see [8], [9], [14]).

NOTE: The pre-shared symmetric key discussed in this chapter is not the same as the shared key associated with GBA.

---

## Annex A (informative): Key pair storage

### A.1 Introduction

The storage of the public/private key pair associated to the requested subscriber certificate is relevant to the procedure of issuing subscriber certificates.

The key pair storage can be performed in different ways. The nature of this storage may have impacts on the trust level associated to the subscriber certificates.

This annex provides a key pair storage security risk analysis in different scenarios.

---

### A.2 Key pair storage use-cases

There are different scenarios to store the public/private key pair associated to the requested subscriber certificate.

#### A.2.1 Key pair storage on the ME

A possible place for the storage of the key pair is the Mobile Equipment.

There are two alternatives for the key pair storage on the ME: key pair storage on the MT or on the TE.

#### A.2.2 Key pair storage on the UICC

Another solution for the storage of the key pair is the UICC.

For the following study we will consider only two key pair storage use-cases: on the ME or on the UICC.

---

### A.3 Threats associated with the key pair

#### A.3.1 Key pair generation

The key pair generation is a very sensitive operation for the secrecy of the private key. The key pair generation has to be of good quality and the exchange, between the device where the key pair generation took place and the device where the key pair will be stored, has to be protected to avoid private key cloning/disclosure. UICC provides a greater level of protection, compared to ME, against unauthorized access to the private key itself.

#### A.3.2 Unauthorized usage of the private key

There are two kinds of threats associated with unauthorized usage of the private key:

1. An attacker getting hold of the private key; and
2. An attacker using the private key of the victim without getting hold of that key.

With respect to threat 1, having the key in UICC offers better protection than having it in the ME. However, an attacker who can compromise the ME can possibly *use* the private key for unauthorized purposes even if it is in the UICC because the UICC does not have direct trusted path to the user.

Attacks due to threat 2 always require an interaction with the UE to gain access to the UICC. While with the threat 1, as soon as the key is retrieved, the associated attacks do not require any interaction with the UE to use the retrieved private key.

### A.3.3 Portability

If the key pair is stored on the Mobile Equipment there is a threat in case of a new UICC inserted in this ME. There will be on the ME personal and sensitive data that do not belong to the new user. Since access to private keys is protected by PINs or passwords, the new user cannot access the private key of the old user unless he knows the PIN or the password.

Also, an important aspect of enrolling subscriber certificates based on AKA is the use of short-lived certificates. With short-lived certificates, even if the new user can access the old user's private key, it could happen that he cannot masquerade as the old user in authorization transactions because he can no longer get subscriber certificates for the key pair on behalf of the old user if the subscriber certificate expired. Moreover, if the key pair in ME is short-lived, owner of the new UICC will not be able to use that key pair after the pair expires. But there is no assumption that the subscriber certificate/key pair expired when the new user gets access to the old user's private key. In general, short-lived keys – on UICC or on ME – are useful for identity and privacy protection. Frequent change of key pair prevents outsiders from linking together transactions made by same user.

### A.3.4 Environment

The threats to the key pair depend on the environment, the place of the key pair storage.

All implementations on mobile terminal, PC, MAC or PDA leave potential risks such as the possibility to load Trojan horses, worms or virus. Software applications lack the protective mechanisms existing in smart card (tamper resistance, physical encapsulation of critical circuitry). Reverse engineering techniques, such as extracting program code and disassembly/debugging methods, are simplified greatly in a software environment, allowing a token's secret components such as cryptographic algorithms, private keys, and other assumed secure information to be recovered.

Currently, the Mobile Equipments do not have all the hardware and software countermeasures that are built into UICC to protect them against invasive and non-invasive attacks performed to retrieve secrets. But mechanisms like code signing are already being taken into use.

### A.3.5 Threat to the required properties for digital signatures

To be valid, digital signatures require the following properties:

- Authenticity: a valid signature implies that the signer deliberately signed the associated message;
- Unforgeability: only the signer can give a valid signature for the associated message;
- Non-re-usability: the signature of a document can not be used on another document;
- Non-repudiation: the signer can not deny having signed a document that has valid signature;
- Integrity: ensure the contents have not been modified.

Those properties involve the secrecy of the keying material, having a trusted input/output path to the user, and the use of strong and secure cryptographic mechanisms.

So, the trust in the digital signatures depends on the storage of the key pair and the related cryptographic computations and the security of communication between the user and the module performing private key operations. The impacts of the key pair storage are studied in the following clause A.4.



---

## A.4 Security risk analysis related to key pair storage

There are many different subscriber use-cases describing the range of applications or services utilizing subscriber certificates. But, the level of trust associated to the proposed services depends on the key pair storage. This will be presented in the following security risk analysis.

### A.4.1 Subscriber certificate use-cases

The use-cases for subscriber certificates can be divided into 2 main categories:

#### A.4.1.1 Secure services

Those services provide convenient way of authenticating cellular subscribers to services. These services can be provided by cellular operators, corporations, or 3<sup>rd</sup> party content providers. Secure services may also support billing.

The different subscriber use-cases could be:

- person-to-person authentication: per-to-per authentication;
- corporate services: authentication to corporate intranet applications;
- person-to-content:
  - access to Presence services;
  - self-service management;
  - access to operator's Web services;
  - access to 3<sup>rd</sup> party content services;
  - enhanced LCS privacy;
  - notifications through cellular network;
  - MBMS security;
  - support of Liberty Alliance use cases;
- small to medium payment through cellular operator.

#### A.4.1.2 Secure connectivity

This service utilizes cellular infrastructure and existing operators customer relationships to authenticate users:

- alternative access authentication:
  - corporate WLAN access authentication;
  - broadband access, e.g. DSL or cable access;
- service authentication: e.g. VPN authentication.

### A.4.2 Security risk analysis in some scenarios

All subscriber use-cases do not require the same level of security for the key pair storage since they propose services that have different features in terms of:

- added value: high or low valued services;
- involved partners and trust relationships: there is agreement between different cellular network operators or between cellular network operator and service provider or 3<sup>rd</sup> party content provider;

- type of required certificates (short-lived or long-term certificates).

This section presents some scenarios where the nature of the key pair storage has security impacts on the service.

### A.4.2.1 Scenarios involving subscriber's personal data

An example of scenario involving subscriber's data could be the self-service management.

#### A.4.2.1.1 Self-service management

This scenario allows user to authenticate to a Web portal, run by operator, to achieve secure access for self-provisioning. Secure end-to-end (TLS) tunnel from the terminal to the Web portal can be established (subscriber's private key and the certificate are used in standard fashion, i.e. no changes needed in TLS components). The user can have either mobile or fixed network access (e.g. GPRS, WLAN, or xDSL). The main use cases are billing information queries and modifying one's subscription profile.

##### **User experience:**

The authorization may be based directly on subscriber certificates, or on a combination of authentication with subscriber certificate and access control list in the Web portal. In the first case the self-management server:

- receives an assertion signed by the data owner, which contains a public key and set of access rights;
- verifies that the sender of the assertion holds the matching private key; and
- allows the secure access (e.g. TLS connection) only if the verification succeeds.

#### A.4.2.1.2 Security Risk Analysis in this scenario

The security risk analysis is performed according to the unauthorized usage threats identified in clause A.3.2.

##### **Unauthorized usage by using the private key of the victim without retrieving the private key:**

##### **Potential attack:**

so, an attacker could get usage of the subscriber private key to authenticate to the Web portal and access for self-provisioning. The attacker could for example modify the subscription profile of the subscriber.

##### **Feasibility:**

the attacker requires an interaction with the UE to gain access to the UICC.

the attack applies in case of:

- key pair storage on the ME;
- key pair storage on the UICC.

##### **Unauthorized usage by getting hold of the private key:**

##### **Potential attack:**

so, an attacker could retrieve the subscriber private key to authenticate to the Web portal and access for self-provisioning. The attacker could for example modify the subscription profile of the subscriber.

**Feasibility:**

once the key retrieved, the attacker does not require any interaction with the UE equipment to gain access to the UICC.

the attack applies in case of:

- key pair storage on the ME

This attack is based on the key retrieval. So, as the UICC is tamper resistant device so the attack does not apply to UICC.

**Consequences of these attacks:**

the self-service management is low added value and the consequences of the key pair storage on the UE are limited.

## A.4.2.2 Scenarios involving payment and agreement between operator and service provider

Some scenarios deal with payment and agreement between cellular network operator and service provider, 3<sup>rd</sup> party.

### A.4.2.2.1 Notifications through cellular network scenario

The subscriber authorizes the operation of sending notifications by service provider through the cellular network. The service provider does not need to know subscriber's identity. If there is no identity information in the certificate, then the subscriber may remain anonymous towards the service provider. However, subscriber may pay for the notification through his phone bill. Subscriber authorizes such payment and the charging is triggered when the service provider sends a notification.

**User experience:**

During a transaction UE sends to the service provider an assertion, i.e. signed authorization, to send a notification message to that UE through the cellular network, and subscriber certificate or subscriber certificate URL. The service provider verifies the authorization text and UE's signature with the aid of subscriber certificate. If the signature and the authorization text are correct, then the service provider will send a positive acknowledgement to the UE.

At a later time, for example when a certain sport's event takes place, the service provider creates a notification and submits it to the operator together with the signed UE's authorization and subscriber's certificate. The operator verifies the signed authorization. If the verification succeeds the operator will forward the notification text to the subscriber in an SMS or MMS message.

### A.4.2.2.2 Small to medium payment through cellular operator scenario

The subscriber authorizes payment for a service through his phone bill (or with separate bill). Note that the provider of the service does not need to know subscriber's identity. If there is no information in the certificate, then the subscriber may remain anonymous towards the service provider. The service may be e.g. non-cellular access in a environment where the operator's traditional billing mechanisms are not directly applicable, e.g. non-cellular access is provided by 3<sup>rd</sup> party.

During a payment transaction the UE sends to the service provider a signed invoice and subscriber certificate (or subscriber certificate URL). The service provider verifies the UE's signature with the aid of subscriber certificate. If the signature and the invoice are correct, then the service provider will grant UE access to, or deliver the requested service.

In the settlement phase the service provider forwards the signed invoice to the operator for verification. If the verification is successful then the operator will reimburse service provider and charge the subscriber the price of the service through his phone bill (or with separate bill).

**Prerequisite:**

the service provider has a business relationship with operator that issued subscriber's certificate and it knows operator's signature verification key.

if the service provider (e.g. visited access network provider abroad) does not have a direct relationship with the subscriber's home network, the certificate should come from the visited network. The independent access network provider trusts the visited operator as well as the subscriber authentication and certificate from that operator.

**User experience:**

the subscriber trusts the billing from the home operator and payment is convenient. During the service usage he will have to type in the payment PIN for configured amounts. The terminal may automatically sign very small amounts. In this case only larger amounts and cumulative sum above a threshold trigger the PIN query.

**A.4.2.2.3 Security Risk Analysis in these scenarios**

These secure services deal with payment and an agreement between a cellular network operator and a service provider. The nature of the key pair storage has consequences. The security risk analysis is performed according to the unauthorized usage threats identified in clause A.3.2.

**Unauthorized usage by using the private key of the victim without retrieving the private key:****Potential attacks:**

if the ME is not sufficiently secure, the attacker may have a program that shows the user a certain message ("payment of €1") but ask the UICC to sign a different message ("payment of €100). Also if the attacker's program discovers the PIN, it can command the UICC to generate signatures even without the user being aware of it.

**Feasibility:**

the attacker requires an interaction with the UE to gain access to the UICC.

these attacks apply in case of:

- key pair storage on the ME;
- key pair storage on the UICC.

**Unauthorized usage by getting hold of the private key:****Potential attacks:**

if an attacker manages to discover the subscriber's private key then an attack could consist in sending signed authorizations to the service provider, then the subscriber would have to pay for services he did not ask for.

**Feasibility:**

once the key is retrieved, the attacker does not require any interaction with the UE equipment to gain access to the UICC.

The attack applies in case of:

- key pair storage on the ME.

This attack is based on the key retrieval. So, as the UICC is a tamper-resistant device, the attack does not apply to UICC.

**Consequences of these attacks:**

- forgeability: the subscriber could pay for services he did not ask for;
- repudiation: The cellular network operator and the service provider are not paid for the service they provided.

If there is any way to attack the system a signer can repudiate the performed signatures arguing that the system is not secure. So, if it is possible to use the subscriber's private key without his deliberate consent, then the subscriber can repudiate the signatures sent for authorization, and not pay the associated phone bill. So,:

- the operator and the service provider could not be paid for the proposed service;
- the trust relationship between the operator and the service provider can be destroyed. The service provider has no guaranty of security; he would no longer trust the subscriber certificates issued by the cellular network operator and the associated signatures;
- if there is any problem due to some unauthorized usages of the subscriber private key then the trust in 3G PKI may be lost;
- high valued services involving payment and relationship with service provider or 3<sup>rd</sup> party content provider often require the use of long-term certificates. The issuance of long-term certificates requires more security constraints than the issuance of short-lived certificates. So, according to the unauthorized usage threats present on the UE, the security level may not satisfy the security requirements for long-term certificates issuance and usage.

### A.4.3 Summary of risk analysis

To prevent the identified unauthorized usages of the private key the following recommendations need to be addressed:

- the storage of the private key and the related cryptographic computations to be done in a secure manner;
- the solution should provide a secure path to the private key usage.

The UICC provides the most secure location for storage and usage of the private key in terms of security (in the form of, e.g. the WIM application). This does not preclude the use of other locations for certain services. On the other hand, the ME can provide a secure path to using the private key (e.g. with mechanisms such as code signing). The combination of solutions will provide a complete secure solution and enable the deployment of secure services.

## Annex B (informative): Change history

Change history							
Date	TSG #	TSG Doc.	CR	Rev	Subject/Comment	Old	New
2003-10	SA3#30				First draft TS: Support for Subscriber Certificates (SSC). Extracted from 33.109 clause 5 and Annex A.		0.1.0
2003-10	SA3#30	S3-020536			Further clarification on WAP Certificate and CRL profile.		0.1.0
2003-10	SA3#30	S3-030537			New interface names		0.1.0
2003-10	SA3#30	S3-030645			Annex A material moved to the main body.	0.1.0	0.1.1
2003-10					Requirements on Zn interface moved to GBA TS.	0.1.0	0.1.1
2003-11	SA3#31	S3-030730			Subscriber Certificate Enrollment Protocol	0.1.1	0.2.0
2003-11	SA3#31	S3-030667			Updated Annex C to 33.109: Key pair storage	0.1.1	0.2.0
2003-11	SA3#31	S3-030795			Results of risk analysis in the "Key Pair Storage" informative annex	0.1.1	0.2.0
2003-11	SA3#31	S3-030796			PSEUDO CR on clarifications on Certificate enrolment using pre-certified keys	0.1.1	0.2.0
2003-11	SA3#31	S3-030797			PSEUDO CR on enrollment of keys in a WIM application	0.1.1	0.2.0
2003-11	SA3#31	S3-030685			PSEUDO CR on on-board key generation in a UICC	0.1.1	0.2.0
2003-11					Changed "session key K" to "session key Ks"	0.1.1	0.2.0
2003-12	SP-22	SP-030584	-	-	Presentation to TSG SA#22 for Information	0.2.0	1.0.0
<del>2004-02</del>	<del>SA3#32</del>	<del>S3-040072</del>			<del>Service discovery for bootstrapping procedure</del>	<del>1.0.0</del>	<del>1.1.0</del>
2004-02	SA3#32	S3-040073			Certificate chain content type	1.0.1	1.4.2
2004-02	SA3#32	S3-040074			Further clarifications on certificate profiles and certificate request	1.0.1	1.4.2
<del>2004-02</del>	<del>SA3#32</del>	<del>S3-040072</del>			<del>Service discovery for bootstrapping procedure</del>	<del>1.0.0</del>	<del>1.1.0</del>
2004-02	SA3#32	S3-040061			Editorial changes	1.0.1	1.4.2
<del>2004-02</del>					<del>Minor editorial changes</del>	<del>1.2.0</del>	<del>1.2.1</del>

# 3GPP TS 33.221 V2.0.0 (2004-03)

---

*Technical Specification*

**3rd Generation Partnership Project;  
Technical Specification Group Services and System Aspects;  
Generic Authentication Architecture (GAA);  
Support for Subscriber Certificates  
(Release 6)**

---



The present document has been developed within the 3<sup>rd</sup> Generation Partnership Project (3GPP<sup>TM</sup>) and may be further elaborated for the purposes of 3GPP.

The present document has not been subject to any approval process by the 3GPP Organizational Partners and shall not be implemented. This Specification is provided for future development work within 3GPP only. The Organizational Partners accept no liability for any use of this Specification. Specifications and reports for implementation of the 3GPP<sup>TM</sup> system should be obtained via the 3GPP Organizational Partners' Publications Offices.

---

Keywords

---

Security, GAA, Subscriber certificates

**3GPP**

Postal address

---

3GPP support office address

---

650 Route des Lucioles - Sophia Antipolis  
Valbonne - FRANCE  
Tel.: +33 4 92 94 42 00 Fax: +33 4 93 65 47 16

Internet

---

<http://www.3gpp.org>

---

**Copyright Notification**

---

No part may be reproduced except as authorized by written permission.  
The copyright and the foregoing restriction extend to reproduction in all media.

© 2004, 3GPP Organizational Partners (ARIB, CCSA, ETSI, T1, TTA, TTC).  
All rights reserved.



# Contents

Foreword.....	5
1 Scope .....	6
2 References .....	6
3 Definitions and abbreviations .....	7
3.1 Definitions.....	7
3.2 Abbreviations.....	7
4 Support for Subscriber Certificates .....	8
4.1 Introduction.....	8
4.2 Reference model.....	8
4.3 Network elements.....	9
4.3.1 PKI Portal.....	9
4.3.2 Bootstrapping Server Function.....	9
4.3.3 User Equipment.....	9
4.4 Requirements and principles for issuing subscriber certificates.....	9
4.4.1 Usage of Bootstrapping .....	9
4.4.2 Access independence.....	9
4.4.3 Roaming and service network support.....	9
4.4.4 Home operator control.....	10
4.4.5 Charging principles .....	10
4.4.6 Subscriber Certificate Profile .....	10
4.4.7 Service Discovery.....	10
4.4.8 Requirements on Ua interface .....	11
4.5 Certificate issuing architecture.....	11
4.5.1 Ua interface .....	11
4.5.1.1 General description.....	11
4.5.1.2 Functionality and protocols .....	12
4.5.1.2.1 PKCS#10 with HTTP Digest Authentication.....	12
4.5.1.2.2 Key Generation .....	12
4.6 Certificate issuing procedure.....	13
4.6.1 Certificate issuing.....	14
4.6.2 CA Certificate delivery.....	16
4.7 Functionality in presence of pre-certified key pair or pre-shared keys .....	17
4.7.1 Presence of pre-certified key pair .....	17
4.7.2 Presence of symmetric pre-shared key .....	18
<b>Annex A (informative): Key pair storage .....</b>	<b>19</b>
A.1 Introduction .....	19
A.2 Key pair storage use-cases.....	19
A.2.1 Key pair storage on the ME.....	19
A.2.2 Key pair storage on the UICC .....	19
A.3 Threats associated with the key pair .....	19
A.3.1 Key pair generation .....	19
A.3.2 Unauthorized usage of the private key .....	19
A.3.3 Portability .....	20
A.3.4 Environment .....	20
A.3.5 Threat to the required properties for digital signatures.....	20
A.4 Security risk analysis related to key pair storage.....	21
A.4.1 Subscriber certificate use-cases .....	21
A.4.1.1 Secure services .....	21
A.4.1.2 Secure connectivity .....	21

A.4.2	Security risk analysis in some scenarios.....	21
A.4.2.1	Scenarios involving subscriber's personal data.....	22
A.4.2.1.1	Self-service management .....	22
A.4.2.1.2	Security Risk Analysis in this scenario .....	22
A.4.2.2	Scenarios involving payment and agreement between operator and service provider.....	23
A.4.2.2.1	Notifications through cellular network scenario .....	23
A.4.2.2.2	Small to medium payment through cellular operator scenario.....	23
A.4.2.2.3	Security Risk Analysis in these scenarios .....	24
A.4.3	Summary of risk analysis .....	25
<b>Annex B (informative): Change history.....</b>		<b>26</b>

---

## Foreword

This Technical Specification has been produced by the 3<sup>rd</sup> Generation Partnership Project (3GPP).

The contents of the present document are subject to continuing work within the TSG and may change following formal TSG approval. Should the TSG modify the contents of the present document, it will be re-released by the TSG with an identifying change of release date and an increase in version number as follows:

Version x.y.z

where:

- x the first digit:
  - 1 presented to TSG for information;
  - 2 presented to TSG for approval;
  - 3 or greater indicates TSG approved document under change control.
- y the second digit is incremented for all changes of substance, i.e. technical enhancements, corrections, updates, etc.
- z the third digit is incremented when editorial only changes have been incorporated in the document.

---

# 1 Scope

The present document describes subscriber certificate distribution by means of generic bootstrapping architecture (GBA) TS 33.220 [11]. Subscriber certificates support services whose provision the mobile operator assists, as well as services that are offered by the mobile operator.

The scope of this specification presents signalling procedures for support of issuing certificates to subscribers and the standard format of certificates and digital signatures. It is not intended to duplicate existing standards being developed by other groups on these topics, and will reference these where appropriate.

---

# 2 References

The following documents contain provisions which, through reference in this text, constitute provisions of the present document.

- References are either specific (identified by date of publication, edition number, version number, etc.) or non-specific.
- For a specific reference, subsequent revisions do not apply.
- For a non-specific reference, the latest version applies. In the case of a reference to a 3GPP document (including a GSM document), a non-specific reference implicitly refers to the latest version of that document *in the same Release as the present document*.

- [1] PKCS#10 v1.7: "Certification Request Syntax Standard", RSA Laboratories, May 2000.
- [2] Adams C., Farrell S.: "Internet X.509 Public Key Infrastructure Certificate Management Protocols", RFC 2510, March 1999.
- [3] Myers M., et al.: "Internet X.509 Certificate Request Message Format", RFC 2511, March 1999.
- [4] Chokhani S., et al.: "Internet X.509 Public Key Infrastructure Certificate Policy and Certification Practices Framework", RFC 2527, March 1999.
- [5] Franks J., et al.: "HTTP Authentication: Basic and Digest Access Authentication", RFC 2617, June 1999.
- [6] Housley R., et al.: "Internet X.509 Public Key Infrastructure Certificate and Certificate Revocation List (CRL) Profile", RFC 3280, April 2002.
- [7] WAP-211-WAPCert, 22.5.2001: <http://www1.wapforum.org/tech/terms.asp?doc=WAP-211-WAPCert-20010522-a.pdf>
- [8] WAP-260-WIM-20010712, 12.7.2001: <http://www1.wapforum.org/tech/documents/WAP-260-WIM-20010712-a.pdf>
- [9] WAP-217-WPKI, 24.4.2001: <http://www1.wapforum.org/tech/documents/WAP-217-WPKI-20010424-a.pdf>
- [10] ITU-T Recommendation X.509 (1997) | ISO/IEC 9594-8:1997: "Information Technology - Open Systems Interconnection - The Directory: Authentication Framework", 1997.
- [11] 3GPP TS 33.220: "3rd Generation Partnership Project; Technical Specification Group Services and System Aspects; Generic Authentication Architecture (GAA); Generic Bootstrapping Architecture".
- [12] 3GPP TS 33.222: "3rd Generation Partnership Project; Technical Specification Group Services and System Aspects; Generic Authentication Architecture (GAA); Access to Network Application Function using HTTPS".

- [13] 3GPP TR 33.919: "3rd Generation Partnership Project; Technical Specification Group Services and System Aspects; Generic Authentication Architecture (GAA); System description".
- [14] Open Mobile Alliance ECMA Crypto Library <http://www.openmobilealliance.org>.
- [15] Blake-Wilson, S., et al, "Transport Layer Security (TLS) Extensions", RFC 3546, June 2003.
- [16] Directive 1999/93/EC of the European Parliament and of the Council of 13 December 1999 on a Community framework for electronic signatures.
- [17] Santesson, S., Polk, W., Barzin, P., and M. Nystrom, "Internet X.509 Public Key Infrastructure Qualified Certificates Profile", RFC 3039, January 2001.
- [18] ETSI TS 101 862: "Qualified certificate profile".
- [19] OMA: "Provisioning Content Version 1.1", Version 13-Aug-2003. Open Mobile Alliance.

---

## 3 Definitions and abbreviations

### 3.1 Definitions

For the purposes of the present document, the following terms and definitions apply.

**Subscriber certificate:** a certificate issued to a subscriber. It contains the subscriber's own public key and possibly other information such as the subscriber's identity in some form.

**CA certificate:** A Certificate Authority signs all certificates that it issues with its private key. The corresponding Certificate Authority public key is itself contained within a certificate, called a CA Certificate.

### 3.2 Abbreviations

For the purposes of the present document, the following abbreviations apply:

AK	Anonymity Key
AKA	Authentication and Key Agreement
BSF	Bootstrapping Server Function
CA	Certificate Authority
CMP	Certificate Management Protocols
GAA	Generic Authentication Architecture
GBA	Generic Bootstrapping Architecture
HSS	Home Subscriber System
IK	Integrity Key
MNO	Mobile Network Operator
NAF	Network Application Function
PKCS	Public-Key Cryptography Standards
PKI	Public Key Infrastructure
UE	User Equipment

## 4 Support for Subscriber Certificates

### 4.1 Introduction

Digital signatures can be used, for instance, to secure mobile commerce, service authorization and accounting. But digital signature by itself is not enough; there is need of a global support for authorization and charging. This TS specifies a global and secure authorization and charging infrastructure of mobile networks to support a local architecture for digital signatures.

Subscriber certificates, issued using the mechanisms described in this TS, provide a migration path towards global Public Key Infrastructure (PKI). A local architecture for digital signatures can be deployed incrementally; one operator can choose to deploy independently of the others. On the other hand, the existence of subscribers and service providers that use digital signatures makes it easier to build a global PKI.

3GPP systems shall issue subscriber certificates in order to authorize and account for service usage both in home and in visited networks. This requires specification of:

1. procedures to issue temporary or long-term certificates to subscribers;
2. standard format of certificates and digital signatures, e.g. re-using OMA wireless PKI specifications.

The mechanism shall allow a cost efficient implementation of the security support of the UE. It will also enable a user's anonymity towards the service provider, whilst the user who invokes the service, can be identified by the network.

Open Mobile Alliance offers an alternative solution for certificate enrolment (c.f. subclause 4.5)

Subscriber certificates support services whose provision the mobile operator assists, as well as services that the mobile operator provides. There is no need to standardize those services in this TS. Also, the communication between service provider and the operator (in the role of certificate issuer) need not be standardized in this TS.

### 4.2 Reference model

Figure 1 shows a simple network model of the entities involved in the certificate issuing, and the interfaces used between the network entities.

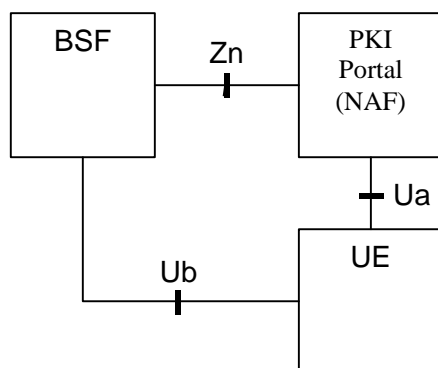

Figure 1: Simple network model for certificate issuing

## 4.3 Network elements

### 4.3.1 PKI Portal

A PKI Portal shall issue a certificate for UE and deliver an operator CA certificate. In both cases, requests and responses are protected by shared key material that has been previously established between UE and a BSF.

In PKI terms, the PKI portal is a Registration Authority (RA) who authenticates the certification request based on cellular subscription. PKI Portal may also function as a Certification Authority (CA) who issues certificates. However, this task may also be done in an existing PKI infrastructure towards which the PKI Portal would function as a RA only, and the CA would be in the PKI infrastructure.

### 4.3.2 Bootstrapping Server Function

The bootstrapping server function (BSF) shall support the PKI portal by providing the authentication (c.f. subclause 4.2.2.1) and subscriber profile information (i.e. whether subscriber is able to enrol a certain types of subscriber certificate).

### 4.3.3 User Equipment

The required new functionality from UE is the support of the Ua interface (i.e. certification enrolment protocol) that is protected using the shared keys established during bootstrapping function.

In addition UE may have the capability to generate public and private key pairs, store the private key part to a non-volatile memory (e.g. in UICC), and protect the usage of the private key part (e.g. with a PIN).

## 4.4 Requirements and principles for issuing subscriber certificates

The following prerequisites for issuing of subscriber certificates exist:

- the UE and the mobile operator's PKI portal share key material to support the certificate request and operator CA certificate retrieval;
- the issuing of the requested certificate is allowed according to the subscriber's profile. The PKI portal is responsible for performing this check before issuing the subscriber certificate;
- in the case that the private key is stored on a WIM [8], which is capable of providing a proof of key origin (assurance info that the key is securely stored in a tamper-resistant device), it shall be possible to send this information with the certificate request.

NOTE: Procedures for providing proof of key origin are not limited to the WIM application.

### 4.4.1 Usage of Bootstrapping

Issuing procedures of the subscriber certificate and operator CA certificate shall be secured by using shared keys obtained from the 3GPP generic bootstrapping architecture as specified in TS 33.220 [11].

### 4.4.2 Access independence

Subscriber certificate and operator CA certificate issuing procedures are access independent. Certificate issuing procedures require IP connectivity from the UE.

### 4.4.3 Roaming and service network support

The roaming subscriber shall be able to request subscriber certificates and operator CA certificates from the home network.

Editor's note: Certificate requests to any than home network may be supported in later phase of the present specification.

#### 4.4.4 Home operator control

Home operator shall be able to control the issuing of subscriber certificates. The control includes to whom the certificates are allowed to issue and the types of issued certificates.

Operator control is supported by information in the subscriber profile. For each type of subscriber certificate, i.e. for different keyUsage in WAP Certificate and CRL Profile, subscriber profile shall contain a flag that allows or disallows the issuing of that type of certificate to subscriber.

Editor's note: Currently two keyUsage values are envisioned: authentication and signing.

Delivery of operator CA certificates is always allowed.

Editor's note: For the first phase of standardisation, only the case is considered where bootstrapping server functionality and network application function are located in the same network as the HSS. Thus is the first phase the home network control does not require any communication between home and visited networks. In later phases, when also visited network may issue certificates, standardized way of transferring the control information from home network to visited network is needed.

#### 4.4.5 Charging principles

The operator shall be capable to charge issuing of subscriber certificates or delivery of operator CA certificates.

Editor's note: The charging mechanism and whether it needs to be standardized in 3GPP is FFS.

#### 4.4.6 Subscriber Certificate Profile

Subscriber certificate profile shall be based on WAP Certificate and CRL Profile [7], which in turn is based on profiles defined in [6] and [10]. A certificate profile defines the format and semantics of certificates in a specific context. WAP Certificate and CRL profiles specification defines four certificate profiles: two user certificate profiles – one for authentication and the other for non-repudiation purposes, server certificate profile for authentication, and authorization certificate profile (i.e., CA certificate). Since subscriber certificates are issued to users, and since services need CA certificate to validate subscriber certificates, the relevant WAP certificate profiles to be used with subscriber certificate profiles are the user certificate profiles, and CA certificate profile.

IETF's and ETSI's Qualified certificate profiles [17,18] may also be used as the subscriber certificate profile if the certification practices followed by the certificate issuing operator fulfil all of the requirements stated in [16,17,18].

The following certificate extensions may be filled with the information given by the UE in the certification request:

- Intended certificate usage (i.e. using keyUsage and/or extKeyUsage extensions [7]).
- Subscriber identities (i.e., subject name field, and possible additional identities defined in the subjectAltName extension [7]). Operator CA shall authorize each suggested subscriber identity.
- Proof of key origin (i.e., keyGenAssertion). Operator CA shall verify the proof of key origin if it is presented.

NOTE: It is not mandatory for Operator CA to insert these suggested extensions by UE to the certificate. Rather, Operator CA shall issue certificates based on its certification policies. It may write a certification practice statement (CPS) [4], where it describes the general requirements and steps taken during the certificate issuing.

#### 4.4.7 Service Discovery

To enable the certificate enrollment procedure, the addresses of bootstrapping server and PKI portal should be configured to the UE. The BSF discovery method is specified in TS 33.220 [11].



**Editor's note:** For the first phase of standardisation, when bootstrapping server functionality and network application function are always located in home network, therefore pre-configuration of addresses may be sufficient. In later phases, however, when UE needs to address of PKI Portal in the visited network, more flexible is needed in the solution.

A procedure needs to be described on how to discover the location of PKI portal. It shall be possible to enable the UE to be configured either manually or automatically via one of the following approaches:

- The address information shall be published via reliable channel. Subscribers shall store all the parameters as part of the establishment of IP connectivity. The address information needs to be input only once.
- The address information shall be pushed automatically to the UE over the air when the subscription to bootstrapping service is accepted. All the parameters shall be saved into the UE and used in the same manner as above. The procedure is specified in [19].

## 4.4.8 Requirements on Ua interface

The requirements for Ua interface are:

- UE shall be able to request for subscriber's certification from the PKI portal that plays the role of the NAF over a network connection;
- NAF shall be able to authenticate UE's certificate request;
- UE shall be able to acquire an operator's CA certificate over the network connection;
- UE shall be able to authenticate the NAF response (i.e., operator CA certificate delivery);
- the procedure shall be independent of the access network used;
- the NAF shall have access to the subscriber profile to check the certification policies. This means that the Zn interface TS 33.220 [11] shall support for retrieving a subset of the subscriber profile;
- the response and delivery of certificate to UE shall be within a few seconds after the initial certification request;
- certification request format shall be PKCS#10;
- certification response format shall be one of the following: a certificate, a pointer to the certificate, or a full certificate chain.

## 4.5 Certificate issuing architecture

### 4.5.1 Ua interface

#### 4.5.1.1 General description

In the certificate issuing, Ua interface is used to for:

- The operator CA certifying subscriber's public keys in format of certificates; and
- The delivery of the Operator CA certificate to the UE.

During subscriber certificate issuing, UE may request a certification of a public key. The supported request format shall be PKCS#10. It is used to encapsulate the public key and other attributes (i.e., subject name, intended key usage, etc.). The request is transported from the UE to the PKI Portal over Ua interface. Upon receiving the certification request, the PKI portal will certify the public key according to its own certification practice policies and subscriber profile which is fetched through BSF from HSS. If PKI Portal decides to certify the public key, it will digitally sign it, and generate the corresponding certificate, which is returned from PKI Portal to the UE, over Ua interface.

During operator CA certificate delivery, the UE may request the PKI Portal to deliver operator CA's certificate. In the corresponding response, the PKI Portal will deliver the CA's certificate to the UE. Since the operator's CA certificate is typically a self-signed certificate and the validation of certificates signed by this CA is based on this particular CA certificate, it needs to be delivered over authenticated and secured channel.

Authentication, integrity protection, and possibly encryption of the messages sent over Ua interface are based on the BSF generated shared secret according to the GBA in TS 33.220 [11], where the PKI portal acts as a Network Application Function (NAF).

#### 4.5.1.2 Functionality and protocols

##### 4.5.1.2.1 PKCS#10 with HTTP Digest Authentication

**Editor's note:** This section uses HTTP Digest authentication to authenticate and integrity protect the certificate request and response. Shared key TLS is another solution to authenticate and protect the certificate enrolment, and whether it should be used instead of HTTP Digest is ffs. This section also needs to be aligned with annex A of the GBA TS.

HTTP Digest Authentication scheme [5] may be done with BSF shared key material the following way:

- UE makes a blank HTTP request to the NAF;
- NAF returns a HTTP response with "WWW-Authenticate" header indicating that HTTP Digest Authentication is needed. Quality of protection (qop) attribute is set to "auth-int" meaning that the content in following HTTP requests and responses are integrity protected;
- UE calculates the correct response to the "WWW-Authenticate" header using the *identifier* (base64 encoded) as the username and the session key Ks\_NAF (base64 encoded) as the password. The session key Ks\_NAF is derived from the key material Ks that resulted from bootstrapping procedure over Ub interface. HTTP Digest Authentication parameters are returned in the "Authorization" header of HTTP Response;
- NAF validates the "Authorization" header and upon successful validation, performs the requested task. In the corresponding HTTP response, NAF calculates the relevant values for "Authentication-Info" header, which is used to authenticate and integrity protect the NAF response;
- UE validates the "Authentication-Info" header and upon successful validation, accepts the payload in the HTTP response.

A PKCS#10 [1] based certification request is sent to the CA NAF using a HTTP POST request, which shall be authenticated and integrity protected by HTTP Digest Authentication.

Certificate is delivered using the HTTP response, which may be authenticated and integrity protected by HTTP Digest Authentication. The content-type of the HTTP response depends on the response format. If a certificate is returned then it is "application/x-x509-user-cert". If a pointer to the certificate is returned then it is "application/vnd.wap.cert-response" as specified in [9]. If a certificate chain is returned, then it is "application/pkix-path" as specified in [15].

The UE requests a CA certificate delivery by sending a plain HTTP GET request with specific parameters in the request URI. The request may be authenticated and integrity protected by HTTP Digest Authentication.

CA certificate is delivered using the HTTP response, which shall be authenticated and integrity protected by HTTP Digest Authentication. The content-type of the HTTP response would be "application/x-x509-ca-cert". Note that the user should always be notified when a new CA certificate is taken into use.

##### 4.5.1.2.2 Key Generation

If the private key is stored in a UICC (e.g. in a WIM) and the UICC demands a special authorization (e.g. from the Operator) to generate the key, the ME may need to perform an HTTP POST request, which MAY be authenticated and integrity protected by HTTP Digest Authentication, to the NAF in order to deliver a nonce that is generated by the UICC. This will allow the NAF to authenticate directly to the UICC application and provide authorization for the key generation.

**Editor's note:** A reference to the relevant OMA specifications should be added.

## 4.6 Certificate issuing procedure

Editor's note: This section uses HTTP Digest authentication to authenticate and integrity protect the certificate request and response. Shared key TLS is another solution to authenticate and protect the certificate enrolment, and whether it should be used instead of HTTP Digest is ffs. This section also needs to be aligned with annex A of the GBA TS.

### 4.6.1 Certificate issuing

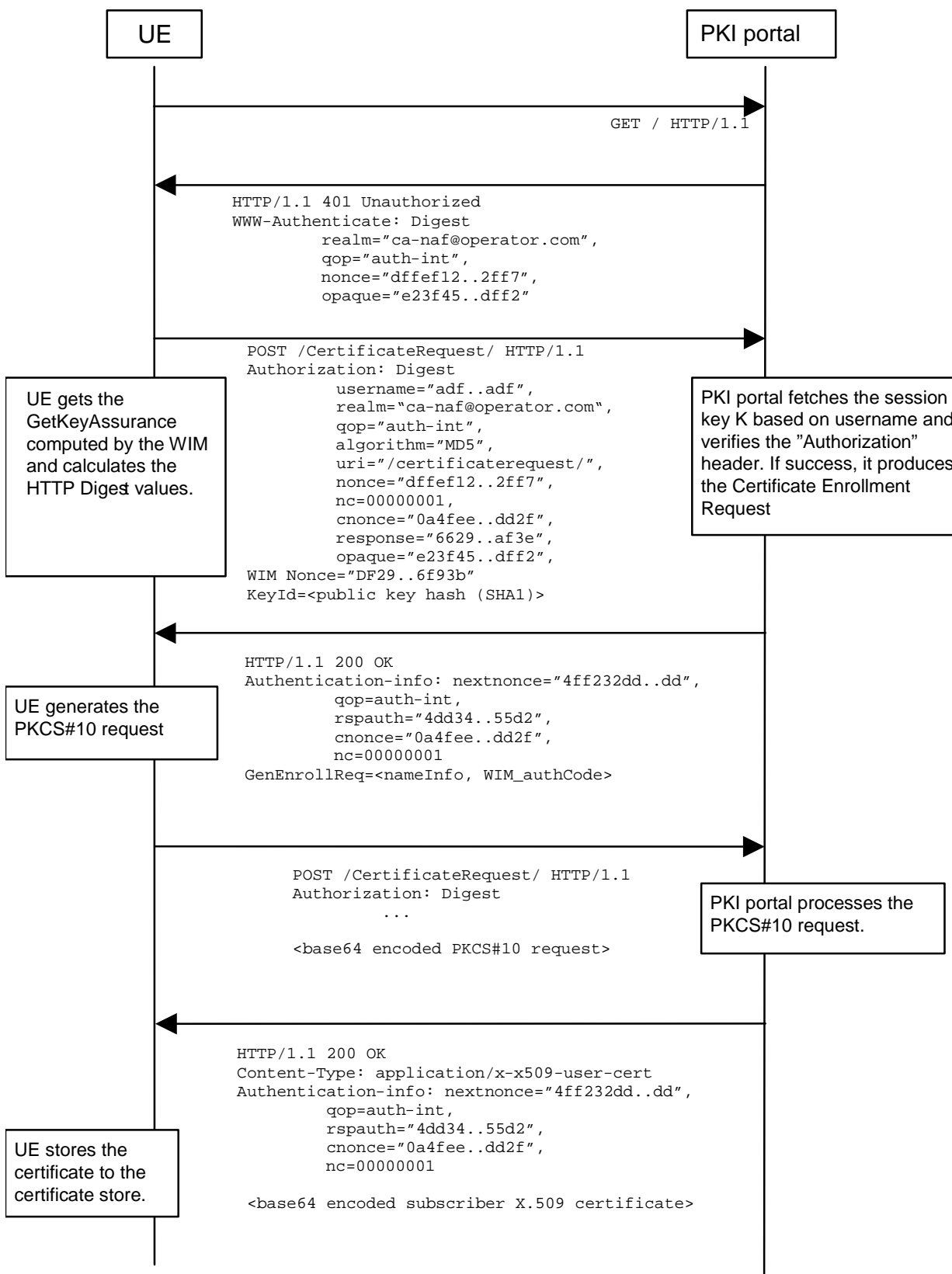

Figure 2: Certificate request using PKCS#10 with HTTP Digest Authentication

The sequence diagram above describes the certificate request when using PKCS#10 with HTTP Digest. The sequence starts with an empty HTTP request to PKI portal. The PKI portal responds with HTTP response code 401 "Unauthorized" which contains a WWW-Authenticate header. The header instructs the UE to use HTTP Digest authentication.

The UE will generate the HTTP request by calculating the Authorization header values using the Transaction Identifier it received from the BSF as username and the session key Ks\_NAF. If the certificate request needs extra assurance by a WIM application for key Proof of Origin, the UE should include a WIM Nonce and the key id (i.e. SHA-1 public key hash) in this request

When PKI portal, acting as an NAF, receives the request, it will verify the Authorization header by fetching the session key Ks\_NAF from the bootstrapping server using the identifier, then calculating the corresponding digest values using Ks\_NAF, and finally comparing the calculated values with the received values in the Authorization header. If the verification succeeds, the PKI portal may use the subscriber profile to compute and send back a GenEnrollReq attribute containing additional parameters that are needed for the following PKCS#10 request generation (e.g. nameInfo, WIM\_authCode, ...). The PKI portal may use session key Ks\_NAF to integrity protect and authenticate this response.

The UE will then generate the PKCS#10 request and send it to the CA NAF by using an HTTP Digest request. In the case that the private key is stored in a WIM application the ME should request the AssuranceInfo from the WIM application and include it in the PKCS#10 request, if provided. The enrolment request will follow the PKCS #10 certificate enrollment format as defined in [1]. Adding AssuranceInfo in this request is defined in the OMA ECMA Script GenEnrollReq specification [14]. The AssuranceInfo provides a proof of origin for the key processing.(e.g. identifies the WIM application and provides a proof that the key is stored in it). UE may indicate the desired format of the certification response: a certificate, a pointer to the certificate (e.g., URL), or a full certificate chain (i.e., from the issued certificate to the corresponding root certificate). The enrolment request shall be as follows:

```
POST <base URL>?response=<indication>[other URL parameters] HTTP/1.1
Content-Type: application/x-pkcs10
```

```
<base64 encoded PKCS#10 blob>
```

where:

<base URL> identifies a server/program.

<indication> used to indicate to the CA NAF what is desired response type for the UE. The possible values are: "single" for subscriber certificate only, "pointer" for pointer to the subscriber certificate, or "chain" for full certificate chain.

[other URL parameters] are additional, optional, URL parameters.

The incoming PKCS#10 request is taken in for further processing. If the CA NAF is actually a registration authority (RA NAF), the PKCS#10 request is forwarded to CA using any protocol available (e.g., CMC or CMP). After the PKCS#10 request has been processed and a certificate has been created, the new certificate is returned to the CA NAF. It will generate a HTTP response containing the certificate, or the pointer to the certificate as defined subclause 7.4 of [9], or a full certificate chain from issued certificate to the root certificate.

If the HTTP response contains the subscriber certificate itself, it shall be base64 encoded, and it may be demarcated as follows:

```
HTTP/1.1 200 OK
Content-Type: application/x-x509-user-cert
```

```
-----BEGIN CERTIFICATE-----
<base64 encoded X.509 certificate blob>
-----END CERTIFICATE-----
```

If the HTTP response contains the pointer to the certificate, the CertResponse structure defined in subclause 7.3.5 of the OMA WPKI [9] shall be used, and it may be demarcated as follows:

```
HTTP/1.1 200 OK
Content-Type: application/vnd.wap.cert-response
```

```
-----BEGIN CERTIFICATE RESPONSE-----
<base64 encoded CertResponse structure blob>
```

-----END CERTIFICATE RESPONSE-----

If the HTTP response contains a full certificate chain in PkiPath structure as defined in [15] and it shall be base64 encoded:

```
HTTP/1.1 200 OK
Content-Type: application/pkix-path
```

<base64 encoded PkiPath blob>

The content-type header value for the certificate chain is "application/pkix-path" as specified in [15].

The PKI portal may use session key Ks\_NAF to integrity protect and authenticate the response, if a certificate or a pointer to the certificate is sent to the UE. The PKI portal shall use integrity protection and authenticate the response if full certificate chain is sent to the UE.

When UE receives the subscriber certificate, it is stored to local certificate management system.

NOTE: On board key generation is already defined in the WIM specification [8] issued by Open Mobile Alliance (OMA) group.

## 4.6.2 CA Certificate delivery

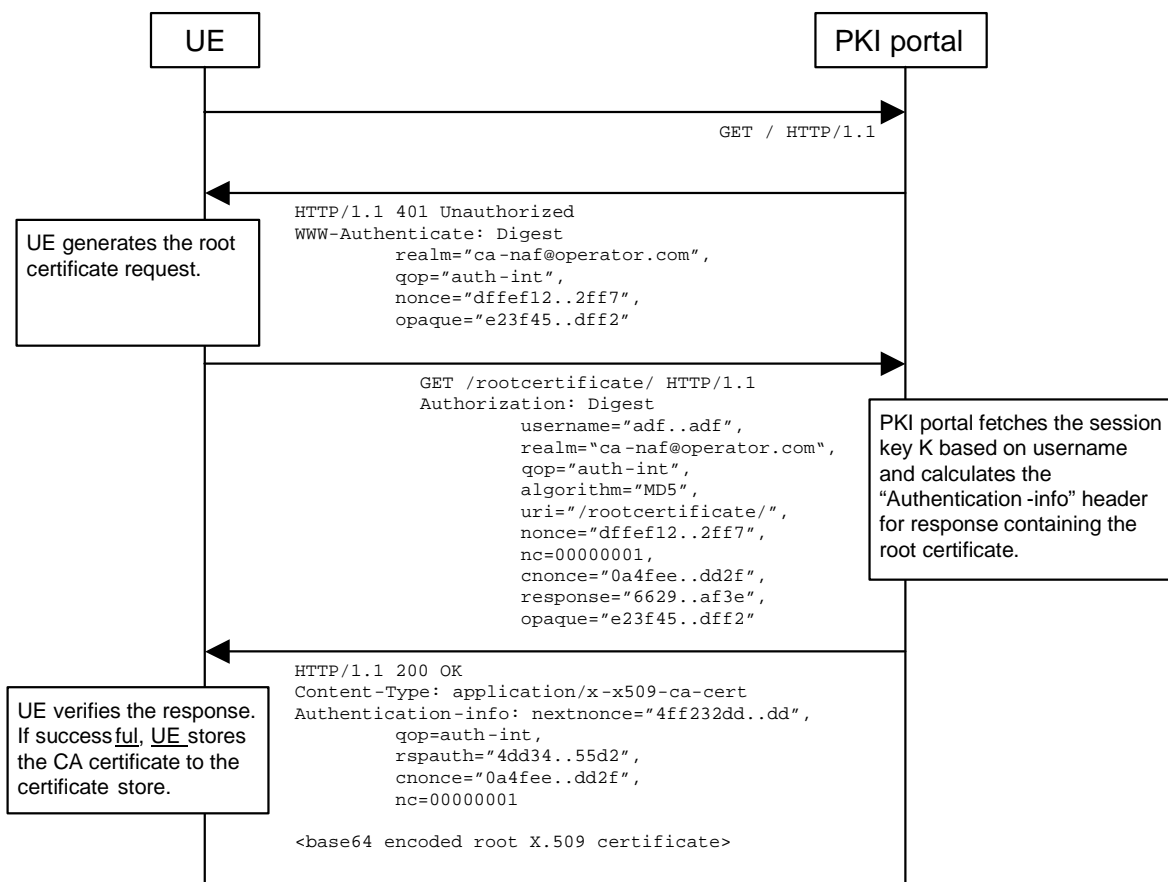

Figure 3: CA certificate delivery with HTTP Digest authentication

The sequence diagram above describes the CA certificate delivery when using HTTP Digest authentication. The sequence starts with an empty HTTP request to CA NAF. The CA NAF responds with HTTP response code 401 "Unauthorized" which contains a WWW-Authenticate header. The header instructs the UE to use HTTP Digest for authentication.

The UE generates another HTTP request for requesting the CA certificate. UE shall indicate the CA issuer name in the request URL as specified in subclause 7.4.1 of [9]. The serial number field shall be omitted. The Authorization header values are calculated using the identifier and the session key Ks\_NAF. The authentication of this HTTP request is not necessary, but it is done in order to follow HTTP Digest authentication specification. Also, the identifier needs to be transported to the CA, i.e. the NAF. A request of subscriber's certificate is specified in subclause 4.4.1.1. The CA certificate delivery request shall be as follows:

```
GET <base URL>?in=<issuer name>[other URL parameters] HTTP/1.1
```

where

<base URL> identifies a server/program.

<issuer name> identifies the certificate issuer. It is a base64 encoding of the DER encoded Issuer field in the X.509 certificate.

[other URL parameters] are additional, optional, URL parameters.

When CA NAF receives the request, it may verify the Authorization header by fetching the session key Ks\_NAF from the bootstrapping server using the identifier. CA NAF will generate a HTTP response containing the CA certificate and use the session key Ks\_NAF to authenticate and integrity protect the HTTP response using the Authentication-info header. Essentially, the response could also be other delivery protocol in HTTP format, e.g. PKCS#7 cryptographic message with content type signedData.

HTTP response contains the CA certificate. The CA certificate shall be base64 encoded, and it may be demarcated as follows:

```
HTTP/1.1 200 OK
Content-Type: application/x-x509-ca-cert

-----BEGIN CERTIFICATE-----
<base64 encoded X.509 certificate blob>
-----END CERTIFICATE-----
```

When UE receives the new CA certificate, it must validate the Authentication-info header. If validation succeeds, the user is notified that a new CA certificate is taken into use. If user accepts the new CA certificate, it is stored to the local certificate management system and marked as "trusted" CA certificate.

## 4.7 Functionality in presence of pre-certified key pair or pre-shared keys

**Editor's note:** Based on contribution S3-030037, it was agreed to add this part into the present document for ffs.

### 4.7.1 Presence of pre-certified key pair

An alternative to securing certificate enrolment based on AKA and bootstrapping function is to secure certificate enrolment based on signatures made with pre-certified key in the UE. This alternative has been specified by Open Mobile Alliance (see section 7.3.4 of [9]) and is thus out of scope of this specification. The functionality in presence of pre-certified key pair in the UE is explained below only briefly.

In this alternative solution, the UE equipped with a UICC, is previously issued with a pre-loaded, long lasting, public/private key pair from the home network. This phase would occur out of band, and would result in the UE possessing a long lasting key pair stored in the UICC for the purposes of certificate request authentication. Open Mobile Alliance (OMA) group offers standardized solutions by means of WPKI specification [9] and WIM specification [8] for the storage and the use of long-lasting key pair. USIM and WIM are examples of applications on the UICC that can deal with the long-lasting keys.

The UE can issue a request for a certificate to the CA, including a proof of origin (e.g. private key is stored in WIM) by using an administrative long lasting private key. The certificate request itself could contain a newly generated public key that is to be certified by the CA. This assumes that the new key pair is generated in the UICC. Access control security for the pre-loaded long-lasting private key should be at least as good as for access control for USIM.

The certificate for the administrative long lasting private key, that provides the proof of generated key origin, is always long lasting certificate. On the other hand the generated user keys in the WIM may have short or long-lived certificate depending on CA policies (see [8], [9], [14]).

#### 4.7.2 Presence of symmetric pre-shared key

Same as above but the administrative key that provides the proof of generated key origin is a shared symmetric key, in which case it does not have a certificate (see [8], [9], [14]).

NOTE: The pre-shared symmetric key discussed in this chapter is not the same as the shared key associated with GBA.



---

## Annex A (informative): Key pair storage

### A.1 Introduction

The storage of the public/private key pair associated to the requested subscriber certificate is relevant to the procedure of issuing subscriber certificates.

The key pair storage can be performed in different ways. The nature of this storage may have impacts on the trust level associated to the subscriber certificates.

This annex provides a key pair storage security risk analysis in different scenarios.

---

### A.2 Key pair storage use-cases

There are different scenarios to store the public/private key pair associated to the requested subscriber certificate.

#### A.2.1 Key pair storage on the ME

A possible place for the storage of the key pair is the Mobile Equipment.

There are two alternatives for the key pair storage on the ME: key pair storage on the MT or on the TE.

#### A.2.2 Key pair storage on the UICC

Another solution for the storage of the key pair is the UICC.

For the following study we will consider only two key pair storage use-cases: on the ME or on the UICC.

---

### A.3 Threats associated with the key pair

#### A.3.1 Key pair generation

The key pair generation is a very sensitive operation for the secrecy of the private key. The key pair generation has to be of good quality and the exchange, between the device where the key pair generation took place and the device where the key pair will be stored, has to be protected to avoid private key cloning/disclosure. UICC provides a greater level of protection, compared to ME, against unauthorized access to the private key itself.

#### A.3.2 Unauthorized usage of the private key

There are two kinds of threats associated with unauthorized usage of the private key:

1. An attacker getting hold of the private key; and
2. An attacker using the private key of the victim without getting hold of that key.

With respect to threat 1, having the key in UICC offers better protection than having it in the ME. However, an attacker who can compromise the ME can possibly *use* the private key for unauthorized purposes even if it is in the UICC because the UICC does not have direct trusted path to the user.

Attacks due to threat 2 always require an interaction with the UE to gain access to the UICC. While with the threat 1, as soon as the key is retrieved, the associated attacks do not require any interaction with the UE to use the retrieved private key.

### A.3.3 Portability

If the key pair is stored on the Mobile Equipment there is a threat in case of a new UICC inserted in this ME. There will be on the ME personal and sensitive data that do not belong to the new user. Since access to private keys is protected by PINs or passwords, the new user cannot access the private key of the old user unless he knows the PIN or the password.

Also, an important aspect of enrolling subscriber certificates based on AKA is the use of short-lived certificates. With short-lived certificates, even if the new user can access the old user's private key, it could happen that he cannot masquerade as the old user in authorization transactions because he can no longer get subscriber certificates for the key pair on behalf of the old user if the subscriber certificate expired. Moreover, if the key pair in ME is short-lived, owner of the new UICC will not be able to use that key pair after the pair expires. But there is no assumption that the subscriber certificate/key pair expired when the new user gets access to the old user's private key. In general, short-lived keys – on UICC or on ME – are useful for identity and privacy protection. Frequent change of key pair prevents outsiders from linking together transactions made by same user.

### A.3.4 Environment

The threats to the key pair depend on the environment, the place of the key pair storage.

All implementations on mobile terminal, PC, MAC or PDA leave potential risks such as the possibility to load Trojan horses, worms or virus. Software applications lack the protective mechanisms existing in smart card (tamper resistance, physical encapsulation of critical circuitry). Reverse engineering techniques, such as extracting program code and disassembly/debugging methods, are simplified greatly in a software environment, allowing a token's secret components such as cryptographic algorithms, private keys, and other assumed secure information to be recovered.

Currently, the Mobile Equipments do not have all the hardware and software countermeasures that are built into UICC to protect them against invasive and non-invasive attacks performed to retrieve secrets. But mechanisms like code signing are already being taken into use.

### A.3.5 Threat to the required properties for digital signatures

To be valid, digital signatures require the following properties:

- Authenticity: a valid signature implies that the signer deliberately signed the associated message;
- Unforgeability: only the signer can give a valid signature for the associated message;
- Non-re-usability: the signature of a document can not be used on another document;
- Non-repudiation: the signer can not deny having signed a document that has valid signature;
- Integrity: ensure the contents have not been modified.

Those properties involve the secrecy of the keying material, having a trusted input/output path to the user, and the use of strong and secure cryptographic mechanisms.

So, the trust in the digital signatures depends on the storage of the key pair and the related cryptographic computations and the security of communication between the user and the module performing private key operations. The impacts of the key pair storage are studied in the following clause A.4.

---

## A.4 Security risk analysis related to key pair storage

There are many different subscriber use-cases describing the range of applications or services utilizing subscriber certificates. But, the level of trust associated to the proposed services depends on the key pair storage. This will be presented in the following security risk analysis.

### A.4.1 Subscriber certificate use-cases

The use-cases for subscriber certificates can be divided into 2 main categories:

#### A.4.1.1 Secure services

Those services provide convenient way of authenticating cellular subscribers to services. These services can be provided by cellular operators, corporations, or 3<sup>rd</sup> party content providers. Secure services may also support billing.

The different subscriber use-cases could be:

- person-to-person authentication: per-to-per authentication;
- corporate services: authentication to corporate intranet applications;
- person-to-content:
  - access to Presence services;
  - self-service management;
  - access to operator's Web services;
  - access to 3<sup>rd</sup> party content services;
  - enhanced LCS privacy;
  - notifications through cellular network;
  - MBMS security;
  - support of Liberty Alliance use cases;
- small to medium payment through cellular operator.

#### A.4.1.2 Secure connectivity

This service utilizes cellular infrastructure and existing operators customer relationships to authenticate users:

- alternative access authentication:
  - corporate WLAN access authentication;
  - broadband access, e.g. DSL or cable access;
- service authentication: e.g. VPN authentication.

### A.4.2 Security risk analysis in some scenarios

All subscriber use-cases do not require the same level of security for the key pair storage since they propose services that have different features in terms of:

- added value: high or low valued services;
- involved partners and trust relationships: there is agreement between different cellular network operators or between cellular network operator and service provider or 3<sup>rd</sup> party content provider;

- type of required certificates (short-lived or long-term certificates).

This section presents some scenarios where the nature of the key pair storage has security impacts on the service.

#### A.4.2.1 Scenarios involving subscriber's personal data

An example of scenario involving subscriber's data could be the self-service management.

##### A.4.2.1.1 Self-service management

This scenario allows user to authenticate to a Web portal, run by operator, to achieve secure access for self-provisioning. Secure end-to-end (TLS) tunnel from the terminal to the Web portal can be established (subscriber's private key and the certificate are used in standard fashion, i.e. no changes needed in TLS components). The user can have either mobile or fixed network access (e.g. GPRS, WLAN, or xDSL). The main use cases are billing information queries and modifying one's subscription profile.

##### **User experience:**

The authorization may be based directly on subscriber certificates, or on a combination of authentication with subscriber certificate and access control list in the Web portal. In the first case the self-management server:

- receives an assertion signed by the data owner, which contains a public key and set of access rights;
- verifies that the sender of the assertion holds the matching private key; and
- allows the secure access (e.g. TLS connection) only if the verification succeeds.

##### A.4.2.1.2 Security Risk Analysis in this scenario

The security risk analysis is performed according to the unauthorized usage threats identified in clause A.3.2.

##### **Unauthorized usage by using the private key of the victim without retrieving the private key:**

##### **Potential attack:**

so, an attacker could get usage of the subscriber private key to authenticate to the Web portal and access for self-provisioning. The attacker could for example modify the subscription profile of the subscriber.

##### **Feasibility:**

the attacker requires an interaction with the UE to gain access to the UICC.

the attack applies in case of:

- key pair storage on the ME;
- key pair storage on the UICC.

##### **Unauthorized usage by getting hold of the private key:**

##### **Potential attack:**

so, an attacker could retrieve the subscriber private key to authenticate to the Web portal and access for self-provisioning. The attacker could for example modify the subscription profile of the subscriber.

**Feasibility:**

once the key retrieved, the attacker does not require any interaction with the UE equipment to gain access to the UICC.

the attack applies in case of:

- key pair storage on the ME

This attack is based on the key retrieval. So, as the UICC is tamper resistant device so the attack does not apply to UICC.

**Consequences of these attacks:**

the self-service management is low added value and the consequences of the key pair storage on the UE are limited.

## A.4.2.2 Scenarios involving payment and agreement between operator and service provider

Some scenarios deal with payment and agreement between cellular network operator and service provider, 3<sup>rd</sup> party.

### A.4.2.2.1 Notifications through cellular network scenario

The subscriber authorizes the operation of sending notifications by service provider through the cellular network. The service provider does not need to know subscriber's identity. If there is no identity information in the certificate, then the subscriber may remain anonymous towards the service provider. However, subscriber may pay for the notification through his phone bill. Subscriber authorizes such payment and the charging is triggered when the service provider sends a notification.

**User experience:**

During a transaction UE sends to the service provider an assertion, i.e. signed authorization, to send a notification message to that UE through the cellular network, and subscriber certificate or subscriber certificate URL. The service provider verifies the authorization text and UE's signature with the aid of subscriber certificate. If the signature and the authorization text are correct, then the service provider will send a positive acknowledgement to the UE.

At a later time, for example when a certain sport's event takes place, the service provider creates a notification and submits it to the operator together with the signed UE's authorization and subscriber's certificate. The operator verifies the signed authorization. If the verification succeeds the operator will forward the notification text to the subscriber in an SMS or MMS message.

### A.4.2.2.2 Small to medium payment through cellular operator scenario

The subscriber authorizes payment for a service through his phone bill (or with separate bill). Note that the provider of the service does not need to know subscriber's identity. If there is no information in the certificate, then the subscriber may remain anonymous towards the service provider. The service may be e.g. non-cellular access in a environment where the operator's traditional billing mechanisms are not directly applicable, e.g. non-cellular access is provided by 3<sup>rd</sup> party.

During a payment transaction the UE sends to the service provider a signed invoice and subscriber certificate (or subscriber certificate URL). The service provider verifies the UE's signature with the aid of subscriber certificate. If the signature and the invoice are correct, then the service provider will grant UE access to, or deliver the requested service.

In the settlement phase the service provider forwards the signed invoice to the operator for verification. If the verification is successful then the operator will reimburse service provider and charge the subscriber the price of the service through his phone bill (or with separate bill).

**Prerequisite:**

the service provider has a business relationship with operator that issued subscriber's certificate and it knows operator's signature verification key.

if the service provider (e.g. visited access network provider abroad) does not have a direct relationship with the subscriber's home network, the certificate should come from the visited network. The independent access network provider trusts the visited operator as well as the subscriber authentication and certificate from that operator.

**User experience:**

the subscriber trusts the billing from the home operator and payment is convenient. During the service usage he will have to type in the payment PIN for configured amounts. The terminal may automatically sign very small amounts. In this case only larger amounts and cumulative sum above a threshold trigger the PIN query.

**A.4.2.2.3 Security Risk Analysis in these scenarios**

These secure services deal with payment and an agreement between a cellular network operator and a service provider. The nature of the key pair storage has consequences. The security risk analysis is performed according to the unauthorized usage threats identified in clause A.3.2.

**Unauthorized usage by using the private key of the victim without retrieving the private key:****Potential attacks:**

if the ME is not sufficiently secure, the attacker may have a program that shows the user a certain message ("payment of €1") but ask the UICC to sign a different message ("payment of €100). Also if the attacker's program discovers the PIN, it can command the UICC to generate signatures even without the user being aware of it.

**Feasibility:**

the attacker requires an interaction with the UE to gain access to the UICC.

these attacks apply in case of:

- key pair storage on the ME;
- key pair storage on the UICC.

**Unauthorized usage by getting hold of the private key:****Potential attacks:**

if an attacker manages to discover the subscriber's private key then an attack could consist in sending signed authorizations to the service provider, then the subscriber would have to pay for services he did not ask for.

**Feasibility:**

once the key is retrieved, the attacker does not require any interaction with the UE equipment to gain access to the UICC.

The attack applies in case of:

- key pair storage on the ME.

This attack is based on the key retrieval. So, as the UICC is a tamper-resistant device, the attack does not apply to UICC.

**Consequences of these attacks:**

- forgeability: the subscriber could pay for services he did not ask for;
- repudiation: The cellular network operator and the service provider are not paid for the service they provided.

If there is any way to attack the system a signer can repudiate the performed signatures arguing that the system is not secure. So, if it is possible to use the subscriber's private key without his deliberate consent, then the subscriber can repudiate the signatures sent for authorization, and not pay the associated phone bill. So,:

- the operator and the service provider could not be paid for the proposed service;
- the trust relationship between the operator and the service provider can be destroyed. The service provider has no guaranty of security; he would no longer trust the subscriber certificates issued by the cellular network operator and the associated signatures;
- if there is any problem due to some unauthorized usages of the subscriber private key then the trust in 3G PKI may be lost;
- high valued services involving payment and relationship with service provider or 3<sup>rd</sup> party content provider often require the use of long-term certificates. The issuance of long-term certificates requires more security constraints than the issuance of short-lived certificates. So, according to the unauthorized usage threats present on the UE, the security level may not satisfy the security requirements for long-term certificates issuance and usage.

### A.4.3 Summary of risk analysis

To prevent the identified unauthorized usages of the private key the following recommendations need to be addressed:

- the storage of the private key and the related cryptographic computations to be done in a secure manner;
- the solution should provide a secure path to the private key usage.

The UICC provides the most secure location for storage and usage of the private key in terms of security (in the form of, e.g. the WIM application). This does not preclude the use of other locations for certain services. On the other hand, the ME can provide a secure path to using the private key (e.g. with mechanisms such as code signing). The combination of solutions will provide a complete secure solution and enable the deployment of secure services.

## Annex B (informative): Change history

Change history							
Date	TSG #	TSG Doc.	CR	Rev	Subject/Comment	Old	New
2003-10	SA3#30				First draft TS: Support for Subscriber Certificates (SSC). Extracted from 33.109 clause 5 and Annex A.		0.1.0
2003-10	SA3#30	S3-020536			Further clarification on WAP Certificate and CRL profile.		0.1.0
2003-10	SA3#30	S3-030537			New interface names		0.1.0
2003-10	SA3#30	S3-030645			Annex A material moved to the main body.	0.1.0	0.1.1
2003-10					Requirements on Zn interface moved to GBA TS.	0.1.0	0.1.1
2003-11	SA3#31	S3-030730			Subscriber Certificate Enrollment Protocol	0.1.1	0.2.0
2003-11	SA3#31	S3-030667			Updated Annex C to 33.109: Key pair storage	0.1.1	0.2.0
2003-11	SA3#31	S3-030795			Results of risk analysis in the "Key Pair Storage" informative annex	0.1.1	0.2.0
2003-11	SA3#31	S3-030796			PSEUDO CR on clarifications on Certificate enrolment using pre-certified keys	0.1.1	0.2.0
2003-11	SA3#31	S3-030797			PSEUDO CR on enrollment of keys in a WIM application	0.1.1	0.2.0
2003-11	SA3#31	S3-030685			PSEUDO CR on on-board key generation in a UICC	0.1.1	0.2.0
2003-11					Changed "session key K" to "session key Ks"	0.1.1	0.2.0
2003-12	SP-22	SP-030584	-	-	Presentation to TSG SA#22 for Information	0.2.0	1.0.0
2004-02	SA3#32	S3-040072			Service discovery for bootstrapping procedure	1.0.0	1.1.0
2004-02	SA3#32	S3-040073			Certificate chain content type	1.1.0	1.2.0
2004-02	SA3#32	S3-040074			Further clarifications on certificate profiles and certificate request	1.1.0	1.2.0
2004-02	SA3#32	S3-040061			Editorial changes	1.1.0	1.2.0
2004-02					Minor editorial changes	1.2.0	1.2.1
2004-03					Editorially updated for presentation to TSG SA #23 for approval	1.2.1	2.0.0