Source: SA5 (Telecom Management)
Title: Rel-5 TS 32.672-200 (State Management IRP: Information Service)
Document for: Approval
Agenda Item: 7.5.3

3GPP TSG-SA5 (Telecom Management)
Meeting #29, Beijing, China, 24-28 June 2002

S5-026494

Presentation of Technical Specification to TSG SA

Presentation to: TSG SA Meeting #17
Document for presentation: TS 32.672, Version 2.0.0
State Management IRP: Information Service
Presented for: Approval

Abstract of document:

This Specification defines the Information Service of the State Management IRP.
Work done against the WID contained in SP-010461 (Work Item ID: OAM-NIM).

Purpose of These Specifications:

This Information Service Specification is intended for Release 5 and is part of the State Management IRP (32.67x-family), which consists of the four specifications, a Requirement Specification (32.671), an Information Service Specification (32.672) and a Stage 3 CORBA Solution Set (32.674) and CMIP Solution Set (32.674) Specifications.

The purpose of this set of specifications is to provide the management state of managed objects, which represents the instantaneous condition of availability and operability of the associated resource from the point of view of management.

The State Management IRP is defined to specify and to standardise the generic attributes for modelling and managing the resources of 3G networks at the Itf-N.

Status of These Specifications:

| | | | | | | | |
|----------|------|-----------|----|----|---|-------|--|
| Jun 2002 | S_16 | SP-020329 | -- | -- | Submitted to TSG SA #16 for Information | 1.0.0 | |
|----------|------|-----------|----|----|---|-------|--|

The State Management IRP: Information Service Specification (32.672) is complete and ready as v2.0.0 for Approval as Release 5.

Outstanding Issues:

None.

Contentious Issues:

None.

3GPP TS 32.672 V2.0.0 (2002-09)

Technical Specification

**3rd Generation Partnership Project;
Technical Specification Group Services and System Aspects;
Telecommunication Management;
Configuration Management (CM);
State Management Integration Reference Point (IRP):
Information service
(Release 5)**



The present document has been developed within the 3rd Generation Partnership Project (3GPP™) and may be further elaborated for the purposes of 3GPP.

The present document has not been subject to any approval process by the 3GPP Organizational Partners and shall not be implemented. This Specification is provided for future development work within 3GPP only. The Organizational Partners accept no liability for any use of this Specification. Specifications and reports for implementation of the 3GPP™ system should be obtained via the 3GPP Organizational Partners' Publications Offices.

Keywords

Configuration Management

3GPP

Postal address

3GPP support office address

650 Route des Lucioles - Sophia Antipolis
Valbonne - FRANCE
Tel.: +33 4 92 94 42 00 Fax: +33 4 93 65 47 16

Internet

<http://www.3gpp.org>

Copyright Notification

No part may be reproduced except as authorized by written permission.
The copyright and the foregoing restriction extend to reproduction in all media.

© 2002, 3GPP Organizational Partners (ARIB, CWTS, ETSI, T1, TTA, TTC).
All rights reserved.

Contents

| | |
|--|-----------|
| Foreword | 4 |
| Introduction | 4 |
| 1 Scope | 5 |
| 2 References | 5 |
| 3 Definitions and abbreviations | 5 |
| 3.1 Definitions | 5 |
| 3.2 Abbreviations | 6 |
| 4 System overview | 6 |
| 4.1 System context for Notification | 6 |
| 5 Information Object Classes (IOCs) | 7 |
| 5.1 Information entities imported and local labels | 7 |
| 5.2 Class diagram | 7 |
| 5.2.1 Attributes and relationships | 7 |
| 5.2.2 Inheritance | 8 |
| 5.3 Information object classes definition | 8 |
| 5.3.1 StateManagementEntity | 8 |
| 5.3.1.1 Definition | 8 |
| 5.3.1.2 Attributes | 8 |
| 5.4 Information attributes definition | 9 |
| 5.4.1 Definition and legal values | 9 |
| Annex A (informative): Change history | 10 |

Foreword

This Technical Specification (TS) has been produced by the 3rd Generation Partnership Project (3GPP).

The present document is 32.672 of the 32.67x-series covering the 3rd Generation Partnership Project; Technical Specification Group Services and System Aspects; Telecommunication management; Configuration Management (CM); State Management Integration Reference Point (IRP), as identified below:

32.671 "Requirements";

32.672 "Information service";

32.673 "CORBA solution set";

32.674 "CMIP solution set".

The contents of the present document are subject to continuing work within the TSG and may change following formal TSG approval. Should the TSG modify the contents of the present document, it will be re-released by the TSG with an identifying change of release date and an increase in version number as follows:

Version x.y.z

where:

- x the first digit:
 - 1 presented to TSG for information;
 - 2 presented to TSG for approval;
 - 3 or greater indicates TSG approved document under change control.
- y the second digit is incremented for all changes of substance, i.e. technical enhancements, corrections, updates, etc.
- z the third digit is incremented when editorial only changes have been incorporated in the document.

Introduction

Configuration Management (CM), in general, provides the operator with the ability to assure correct and effective operation of the 3G network as it evolves. CM actions have the objective to control and monitor the actual configuration on the Network Elements (NEs) and Network Resources (NRs), and they may be initiated by the operator or by functions in the Operations Systems (OSs) or NEs.

CM actions may be requested as part of a deployment program (e.g. additions and deletions), as part of an optimisation program (e.g. modifications), and to maintain the overall Quality of Service (QoS). The CM actions are initiated either as single actions on single NEs of the 3G network, or as part of a complex procedure involving actions on many resources/objects in one or several NEs.

1 Scope

The present document defines the Information Service (IS) part of the State Management IRP. It specifies the semantics of the network resource state and status information visible across the Itf-N. It also specifies the interaction required for the management of the state and status information.

The state and status attributes specified in this document shall be used, where applicable, as attributes in Information Object Class (IOC) definitions of other 3GPP IRPs. When used by the IOC definition, the semantics of the state and status attributes can be qualified and enhanced if deemed necessary.

2 References

The following documents contain provisions which, through reference in this text, constitute provisions of the present document.

- References are either specific (identified by date of publication, edition number, version number, etc.) or non-specific.
- For a specific reference, subsequent revisions do not apply.
- For a non-specific reference, the latest version applies. In the case of a reference to a 3GPP document (including a GSM document), a non-specific reference implicitly refers to the latest version of that document *in the same Release as the present document*.

- [1] 3GPP TS 32.101: "3G Telecom Management principles and high level requirements".
- [2] 3GPP TS 32.102: "3G Telecom Management Architecture".
- [3] 3GPP TS 32.300: "Telecommunication management; Configuration Management (CM); Name convention for Managed Objects".
- [4] 3GPP TS 32.302: "Telecommunication management; Configuration Management; Notification Integration Reference Point; Information Service version 1".
- [5] 3GPP TS 32.312: "Telecommunication management; Generic Integration Reference Point (IRP) management; Information service".
- [6] 3GPP TS 32.600: "Telecommunication management; Configuration Management (CM); Concept and main requirements".
- [7] ITU-T Recommendation X.731: "Information technology - Open Systems Interconnection - Systems Management: State management function".
- [8] ITU-T Recommendation X.733: "Information technology - Open Systems Interconnection - Systems Management: Alarm reporting function".

3 Definitions and abbreviations

3.1 Definitions

For the purposes of the present document, the terms and definitions given in 3GPP TS 32.101 [1], 3GPP TS 32.102 [2] and 3GPP TS 32.600 [6] apply.

3.2 Abbreviations

For the purposes of the present document, the following abbreviations apply:

| | |
|-----|--|
| CM | Configuration Management |
| EM | Element Manager |
| IOC | Information Object Class |
| IRP | Integration Reference Point |
| IS | Information Service (see 3GPP TS 32.101 [1]) |
| M | Mandatory |
| NE | Network Element |
| NM | Network Manager |
| NR | Network Resource |
| O | Optional |
| OMG | Object Management Group |
| OS | Operations System |
| QoS | Quality of Service |
| UML | Unified Modelling Language (OMG) |

4 System overview

4.1 System context for Notification

Figure 1 and figure 2 identify System contexts of State Management IRP in terms of implementations called IRPAgent and IRPManager. For a definition of IRPManager and IRPAgent, see 3GPP TS 32.102 [2].

The IRPAgent implements and supports the State Management IRP attributes. The IRPAgent can be an Element Manager (EM) or a mediator that interfaces one or more NEs (see figure 1), or it can be a Network Element (NE) (see figure 2). In the former case, the interfaces (represented by a thick dotted line) between the EM and the NEs are not subject of this IS.

An IRPManager using this IRP shall choose one of the two System Contexts defined here, for each NE. For instance, if an EM is responsible for managing a number of NEs, the NM shall access this IRP through the EM and not directly to those NEs. For another IRP though, the System Context may be different.

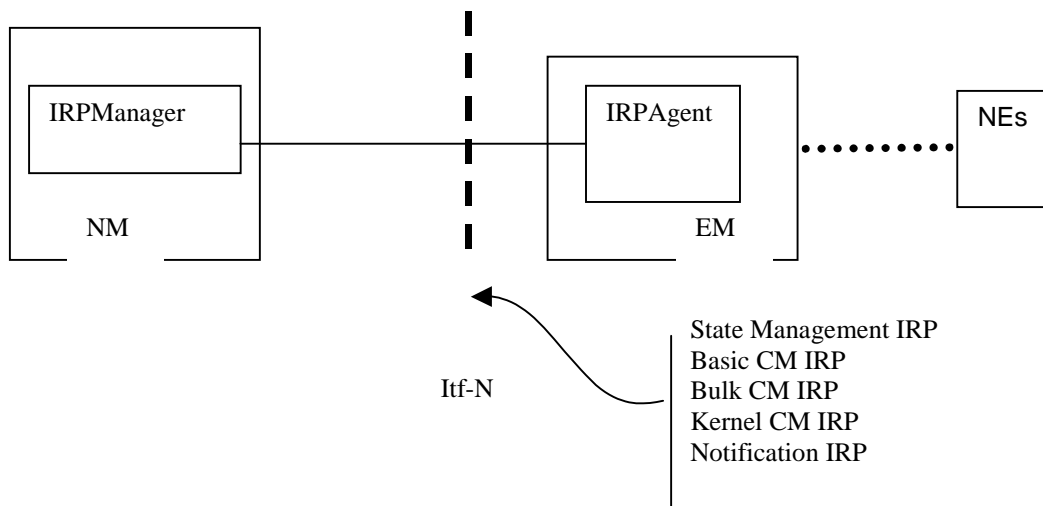

Figure 1: System Context A

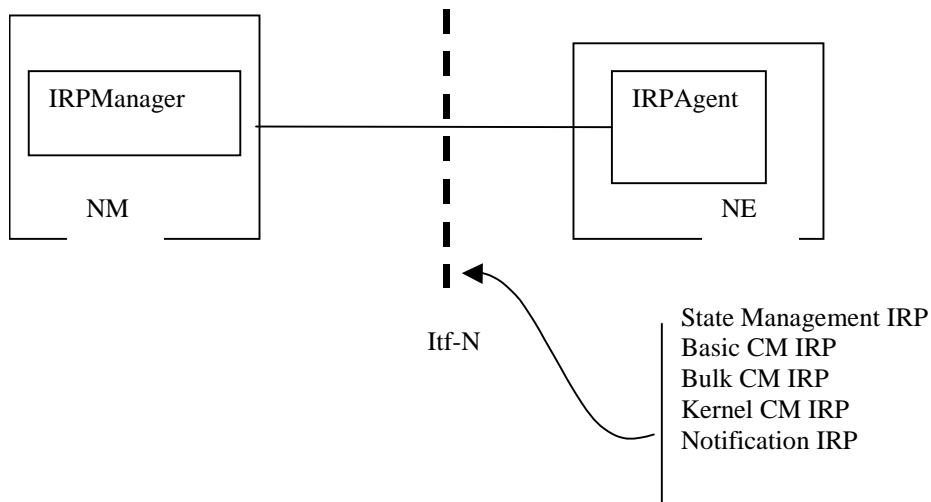

Figure 2: System Context B

5 Information Object Classes (IOCs)

5.1 Information entities imported and local labels

Table 5.1

| Label reference | Local label |
|-----------------|-------------|
| | |
| | |

There are no information entities imported.

5.2 Class diagram

5.2.1 Attributes and relationships

This subclause depicts the set of information object classes (IOCs) that encapsulate information within the Generic State Management IRP. The intent is to identify the information required for the State Management IRP implementation of its operations and notification emission. This subclause provides the overview of all information object classes in UML. Subsequent subclauses provide more detailed specification of various aspects of these information object classes.

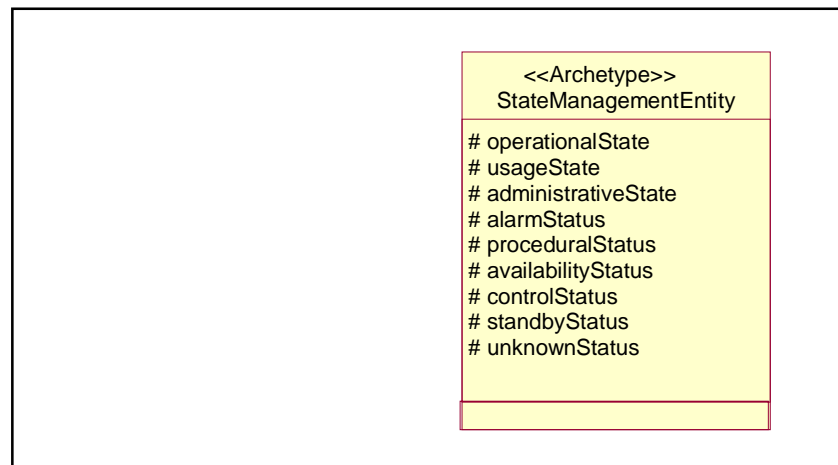

Figure 5.1

5.2.2 Inheritance

There are no inheritance relationships.

5.3 Information object classes definition

5.3.1 StateManagementEntity

5.3.1.1 Definition

StateManagementEntity is a Archetype, that may represent any IOC defined in the Network Resource Models, e.g. Generic Network Resource Model, Core Network Resource Model, UTRAN Network Resource Model or GERAN Network Resource Model.

The attributes defined for this Archetype can be imported and used in any IOC of the Network Resource Models, where such attributes are needed. These attributes shall be used in the same way as defined in the ITU-T Recommendation X.731 [7] and ITU-T Recommendation X.733 [8], unless otherwise stated. That document gives also examples of state diagrams, defining possible state transitions when one or more of the state attributes defined here are used in a class.

5.3.1.2 Attributes

The following attributes are defined for this information object class.

Table 5.2

| Attribute name | Support Qualifier |
|---------------------|-------------------|
| operationalState | N/A |
| usageState | N/A |
| administrativeState | N/A |
| alarmStatus | N/A |
| proceduralStatus | N/A |
| availabilityStatus | N/A |
| controlStatus | N/A |
| standbyStatus | N/A |
| unknownStatus | N/A |

5.4 Information attributes definition

5.4.1 Definition and legal values

The following table gives the definition and legal values for each attribute.

Table 5.3

| Attribute Name | Definition | Legal Values |
|---------------------|--|---|
| operationalState | It indicates the operational state of the object instance. "It describes whether or not the resource is physically installed and working." [7] This attribute is READ-ONLY. | "Enabled", "Disabled" The meaning of these values is as defined in ITU-T Recommendation X.731 [7]. |
| usageState | It indicates the usage state of the object instance. "It describes whether or not the resource is actively in use at a specific instant, and if so, whether or not it has spare capacity for additional users at that instant." [7] This attribute is READ-ONLY. | "Idle", "Active", "Busy" The meaning of these values is as defined in ITU-T Recommendation X.731 [7]. |
| administrativeState | It indicates the administrative state of the object instance. "It describes the permission to use or prohibition against using the resource, imposed through the management services." [7] | "Locked", "Shutting down", "Unlocked" The meaning of these values is as defined in ITU-T Recommendation X.731 [7]. |
| alarmStatus | It indicates the alarm status of the object instance. This is mapped to the perceived severity of the most severe active alarm associated to the object instance. | "Cleared", "Indeterminate", "Warning", "Minor", "Major", "Critical", The meaning of these values is as defined for the attribute perceived severity in ITU-T Recommendation X.733 [8]. |
| proceduralStatus | It indicates the procedural status of the object instance. | A set consisting of zero or more of the following values: "Initialisation required", "Not initialised", "Initialising", "Reporting", "Terminating". The meaning of these values is as defined in ITU-T Recommendation X.731 [7]. |
| availabilityStatus | It indicates the availability status of the object instance. | A set consisting of zero or more of the following values: "In test", "Failed", "Power off", "Off line", "Off duty", "Dependency", "Degraded", "Not installed", "Log full" The meaning of these values is as defined in ITU-T Recommendation X.731 [7]. |
| controlStatus | It indicates the control status of the object instance. | A set consisting of zero or more of the following values: "Subject to test", "Part of services locked", "Reserved for test", "Suspended" . The meaning of these values is as defined in ITU-T Recommendation X.731 [7]. |
| standbyStatus | It indicates the standby status of the object instance. | "Hot standby", "Cold standby", "Providing service", . The meaning of these values is as defined in ITU-T Recommendation X.731 [7]. |
| UnknownStatus | It indicates whether the state of the resource represented by the managed object is unknown. | "True" (state is unknown, the values of the state attributes may not reflect the actual state of the resource); "False" (state is known, the values of the state attributes reflect the actual state of the resource). |

Annex A (informative): Change history

| Change history | | | | | | | |
|----------------|-------|-----------|----|-----|---|-------|-----|
| Date | TSG # | TSG Doc. | CR | Rev | Subject/Comment | Old | New |
| Jun 2002 | S_16 | SP-020329 | -- | -- | Submitted to TSG SA #16 for Information | 1.0.0 | |
| Sep 2002 | S_17 | SP-020469 | -- | -- | Submitted to TSG SA #17 for Approval | 2.0.0 | |
| | | | | | | | |
| | | | | | | | |
| | | | | | | | |