Source: SA5 (Telecom Management)
Title: 2 Rel-5 CR 32.102 (3G Telecom Management Architecture)
Document for: Decision
Agenda Item: 7.5.3

Doc-1st-Level	Spec	CR	Phase	Subject	Category	Version - Current	Version - New	Doc-2nd-Level	Workitem
SP-020014	32.102	018	Rel-5	Add the rule on how all SA5 Solution Set specifications indicate a reference to a particular SA5 Information Service specification.	F	4.2.0	5.0.0	S5-010802	OAM-AR
SP-020014	32.102	019	Rel-5	Inclusion of the IMS in the 3G Telecom Management Architecture (32.102)	B	4.2.0	5.0.0	S5-020170	OAM-AR

CHANGE REQUEST

⌘ **32.102 CR 018** ⌘ ev **-** ⌘ Current version: **4.2.0** ⌘

For **HELP** on using this form, see bottom of this page or look at the pop-up text over the ⌘ symbols.

Proposed change affects: ⌘ (U)SIM ME/UE Radio Access Network Core Network

Title:	⌘	Add the rule on how all SA5 Solution Set specifications indicate a reference to a particular SA5 Information Service specification.	
Source:	⌘	SA5	
Work item code:	⌘	OAM-AR	Date: ⌘ 18/01/2002
Category:	⌘	B	Release: ⌘ REL-5
		Use <u>one</u> of the following categories: F (correction) A (corresponds to a correction in an earlier release) B (addition of feature), C (functional modification of feature) D (editorial modification) Detailed explanations of the above categories can be found in 3GPP TR 21.900.	Use <u>one</u> of the following releases: 2 (GSM Phase 2) R96 (Release 1996) R97 (Release 1997) R98 (Release 1998) R99 (Release 1999) REL-4 (Release 4) REL-5 (Release 5)

Reason for change:	⌘	Solution Set (SS) specifications do not have explicit reference to the related Information Service (IS) specifications. SS readers need such reference since the semantics of the SS constructs are defined in the related IS specification.
Summary of change:	⌘	Add a new sub-clause that specifies the rule on how all Solution Set specifications shall indicate a reference to a particular Information Service specification. Remove a superfluous and confusing statement in sub-clause E.1.
Consequences if not approved:	⌘	The semantics of the Solution Set constructs may be ambiguous.

Clauses affected:	⌘	Annex E.
Other specs affected:	⌘	<input type="checkbox"/> Other core specifications ⌘ <input type="checkbox"/> Test specifications <input type="checkbox"/> O&M Specifications
Other comments:	⌘	

Annex E (informative): General rules for Solution Sets

E.1 Introduction

The intent of this annex is twofold. The first intent is for 3GPP internal use to document how a 3GPP Solution Set is produced and what it shall contain. The second intent with the annex is to give the reader of an IS or a Solution Set a better understanding on how to interpret the IS or Solution Set document.

~~It can be noted that it is expected that this annex is to be extended in later version of this document.~~

E.2 Solution Set versioning

For further study.

E.3 Referenced Information Service Specification

A sentence shall be included in the clause “Scope” of all Solution Set specifications. The sentence shall read as follows.

“This Solution Set specification is related to Z.”

where Z is the 3GPP Information Service specification number including the version, such as “3G TS 32.111-2 V4.1.X” for the case of Alarm Integration Reference Point: Information Service. Note that ‘X’, rather than the actual digit, is actually used in the sentence. This is because the value of X is not relevant for the reference purpose since different values of X identify different 3GPP published specifications that reflect only minor editorial changes.

CHANGE REQUEST

⌘ **32.102** **CR 019** ⌘ rev **-** ⌘ Current version: **4.2.0** ⌘

For **HELP** on using this form, see bottom of this page or look at the pop-up text over the ⌘ symbols.

Proposed change affects: ⌘ (U)SIM ME/UE Radio Access Network Core Network

Title:	⌘ Inclusion of the IMS in the 3G Telecom Management Architecture (32.102)		
Source:	⌘ SA5		
Work item code:	⌘ OAM-AR	Date:	⌘ 01/03/2002
Category:	⌘ B Use <u>one</u> of the following categories: F (correction) A (corresponds to a correction in an earlier release) B (addition of feature), C (functional modification of feature) D (editorial modification) Detailed explanations of the above categories can be found in 3GPP TR 21.900 .	Release:	⌘ REL-5 Use <u>one</u> of the following releases: 2 (GSM Phase 2) R96 (Release 1996) R97 (Release 1997) R98 (Release 1998) R99 (Release 1999) REL-4 (Release 4) REL-5 (Release 5)

Reason for change:	⌘ To include the IMS
Summary of change:	⌘ General updating of diagrams to show the existence of the IMS
Consequences if not approved:	⌘ The description of the 3G Telecom Management Architecture would be incomplete.

Clauses affected:	⌘ 3.2, 7.3.2, 7.3.3, Annex B
Other specs affected:	⌘ <input type="checkbox"/> Other core specifications ⌘ <input type="checkbox"/> <input type="checkbox"/> Test specifications <input type="checkbox"/> O&M Specifications
Other comments:	⌘

How to create CRs using this form:

Comprehensive information and tips about how to create CRs can be found at:
http://www.3gpp.org/3G_Specs/CRs.htm. Below is a brief summary:

- 1) Fill out the above form. The symbols above marked ⌘ contain pop-up help information about the field that they are closest to.
- 2) Obtain the latest version for the release of the specification to which the change is proposed. Use the MS Word "revision marks" feature (also known as "track changes") when making the changes. All 3GPP specifications can be downloaded from the 3GPP server under <ftp://ftp.3gpp.org/specs/>. For the latest version, look for the directory name with the latest date e.g. 2001-03 contains the specifications resulting from the March 2001 TSG meetings.
- 3) With "track changes" disabled, paste the entire CR form (use CTRL-A to select it) into the specification just in front of the clause containing the first piece of changed text. Delete those parts of the specification which are not relevant to the change request.

multiple systems within a subject area link and inter-operate, and may describe the internal construction or operations of particular systems within the architecture.

UMTS Organisation: A legal entity that is involved in the provisioning of UMTS.

3.2 Abbreviations

For the purposes of the present document, the following abbreviations apply:

3G	3 rd Generation
ATM	Asynchronous Transfer Mode
BG	Border Gateway
BGCF	Breakout Gateway Control Function
BSC	Base Station Controller
BSS	Base Station Subsystem
BTS	Base Transceiver Station
CIM	Common Information Model Specification (from DMTF)
CMIP	Common Management Information Protocol
CMIS	Common Management Information Service
CMISE	Common Management Information Service Element
CORBA	Common Object Request Broker Architecture
CSCF	Call Session Control Function
DCN	Data Communication Network
DECT	Digital Enhanced Cordless Telecommunications
DSS1	Digital Subscriber System 1
E-OS	Element Management Layer-Operations System
F/W	Firewall
FM	Fault Management
FTAM	File Transfer, Access and Management
GDMO	Guidelines for the Definition of Managed Objects
GGSN	Gateway GPRS Support Node
GPRS	General Packet Radio Service
HLR	Home Location Register
HTTP	HyperText Transfer Protocol
HW	Hardware
I-CSCF	Interrogating CSCF
IDL	Interface Definition Language
IIOP	Internet Inter-ORB Protocol
IM	Information Model
IM-MGW	IP Multimedia Media Gateway
IMS	IP Multimedia Subsystem
INAP	Intelligent Network Application Part
IP	Internet Protocol
IRP	Integration Reference Point
IS	Information Service
ISDN	Integrated Services Digital Network
IWU	Inter Working Unit
MD	Mediation Device
MGCF	Media Gateway Control Function
MIB	Management Information Base
MMI	Man-Machine Interface
MML	Man-Machine Language
MRFC	Multimedia Resource Function Controller
MRFP	Multimedia Resource Function Processor
MSC	Mobile service Switching Centre
NE	Network Element
N-OS	Network Management Layer-Operations System
NR	Network Resource
NRM	Network Resource Model
NSS	Network Switching Subsystem

NW	Network
OMG	Object Management Group
OS	Operations System
OSF	Operations System Functions
P-CSCF	Proxy CSCF
PDH	Plesiochronous Digital Hierarchy
PSA	Product Specific Applications
PSTN	Public Switched Telephone Network
QA	Q-Adapter
QoS	Quality of Service
RNC	Radio Network Controller
RSVP	Resource ReserVation Protocol
S-CSCF	Serving CSCF
SDH	Synchronous Digital Hierarchy
SGSN	Serving GPRS Support Node
SGW	Signalling Gateway
SLA	Service Level Agreement
SLF	Subscription Locator Function
SMI	Structure of Management Information
SNM	Sub-Network Manager
SNMP	Simple Network Management Protocol
SS	Solution Set
SS7	Signalling System No. 7
SW	Software
TM	Telecom Management
TMN	Telecommunications Management Network as defined in ITU-T Recommendation M.3010 [1].
UML	Unified Modelling Language
UMTS	Universal Mobile Telecommunications System
UTRA	Universal Terrestrial Radio Access
UTRAN	Universal Terrestrial Radio Access Network
VHE	Virtual Home Environment
VLR	Visitor Location Register
WBEM	Web Based Enterprise Management
WS	Workstation

4 General

4.1 UMTS

4.1.1 UMTS Reference Model

A Universal Mobile Telecommunications System is made of the following components:

- one or more Access Networks, using different types of access techniques (GSM, UTRA, DECT, PSTN, ISDN,...) of which at least one is UTRA;
- one or more Core Networks;
- one or more Intelligent Node Networks, service logic and mobility management, (IN, GSM...);
- one or more transmission networks (PDH, SDH etc) in various topologies (point-to-point, ring, point-to-multipoint etc) and physical means (radio, fibre, copper etc).

The UMTS components have signalling mechanisms among them (DSS1, INAP, MAP, SS7, RSVP etc.).

From the service perspective, the UMTS is defined to offer:

- service support transparent to the location, access technique and core network, within the bearer capabilities available in one particular case;

- user to terminal and user to network interface (MMI) irrespective of the entities supporting the services required (VHE);
- multimedia capabilities.

Numerous of different interfaces can be identified in a UMTS network in the areas of network element management, network management and service management. The most important and complex of these interfaces will be standardised but many interfaces of less importance are unlikely to be fully standardised and will be up to the individual operator and vendor to develop. To adopt mainstream computing technologies, re-use widely used protocols, standards and an open system architecture will be essential to secure interworking between all physical entities in a UMTS.

Low-cost and general access to management systems information will be needed. Obviously this is the critical issue and challenging task in the heterogeneous, distributed and complex network of a UMTS.

7.3.2 Interfaces

A UMTS will consist of many different types of components based on different types of technologies. There will be access-, core-, transmission- and intelligent node networks and many of the UMTS components have already been the targets for Telecom Management standardisation at different levels. Many of these standards will be reused and the management domain of a UMTS will thereby consist of many TMNs. The architecture of UMTS TMNs should support distributed TMNs and TMN-interworking on peer-to-peer basis.

The Telecom Management Architecture can vary greatly in scope and detail, because of scale of operation and that different organisations may take different roles in a UMTS (see clause 5). The architecture of UMTS TMNs should provide a high degree of flexibility to meet the various topological conditions as the physical distribution and the number of NEs. Flexibility is also required to allow high degree of centralisation of personnel and the administrative practices as well as allowing dispersion to administrative domains (see further clause 10). The 3G Telecom Management architecture should be such that the NEs will operate in the same way, independently of the OS architecture.

Figure 7.2 illustrates the basic domains in UMTS (identified in 3GPP Technical Standards [12], [13]), related management functional areas and introduces Interface-N (Itf-N).

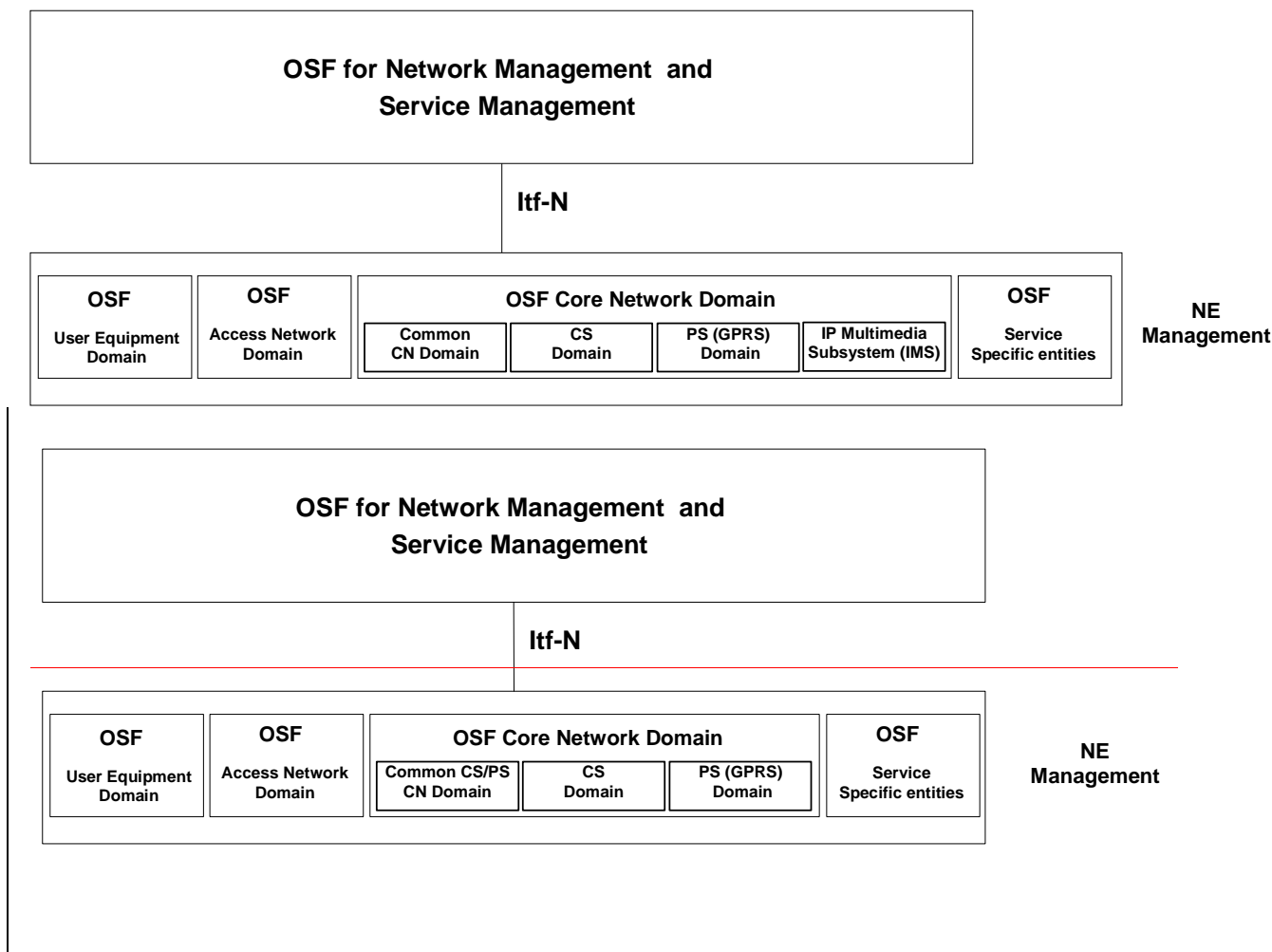

Figure 7.2: Overview of UMTS Telecom Management Domains and Itf-N

Itf-N between the NE OSFs and NM/SM OSFs could be used by the network- and service management systems to transfer management messages, notifications and service management requests via the NE OSF to the Network Elements (NEs).

This interface shall be open and the information models standardised.

Telecom management interfaces may be considered from two perspectives:

1. the management information model;
2. the management information exchange.

The management information models will be standardised in other 3GPP documents but the management information exchange will be further described in this architectural standard.

The management task will vary greatly between different network elements in a UMTS. Some NEs are of high complexity e.g. a RNC, while others e.g. a border gateway is of less complexity. Different application protocols can be chosen to best suite the management requirements of the different Network Elements and the technology used.

Application protocols can be categorised out of many capabilities as:

- Functionality;
- Implementation complexity;
- Processor requirements;
- Cost efficiency;
- Market acceptance, availability of "off the shelf commercial systems and software".

For each Telecom Management interface that will be standardised by 3GPP at least one of the accepted protocols will be recommended. Accepted application protocols (e.g. CMIP, SNMP, CORBA IIOP) are defined in 3GPP TS 32.101 [2], Annex A.

7.3.3 Basic entities of a UMTS

To provide the mobile service as it is defined in a UMTS, some specific functions are introduced [12]. These functional entities can be implemented in different physical equipments or gathered. In any case, exchanges of data occur between these entities and from the Telecom Management perspective they can all normally be treated as network elements of a UMTS. The basic telecom management functional areas as fault management, configuration management, performance management and security management are all applicable to these UMTS entities. As such they are all the targets for UMTS Telecom Management technical standards.

As discussed in clause 5, there will be many possible ways to build a UMTS and thereby many possible architectures of a mobile system. The entities presented in figures 7.3a,b,c,d should be treated as the fundamental building blocks of any possible implementation of a UMTS.

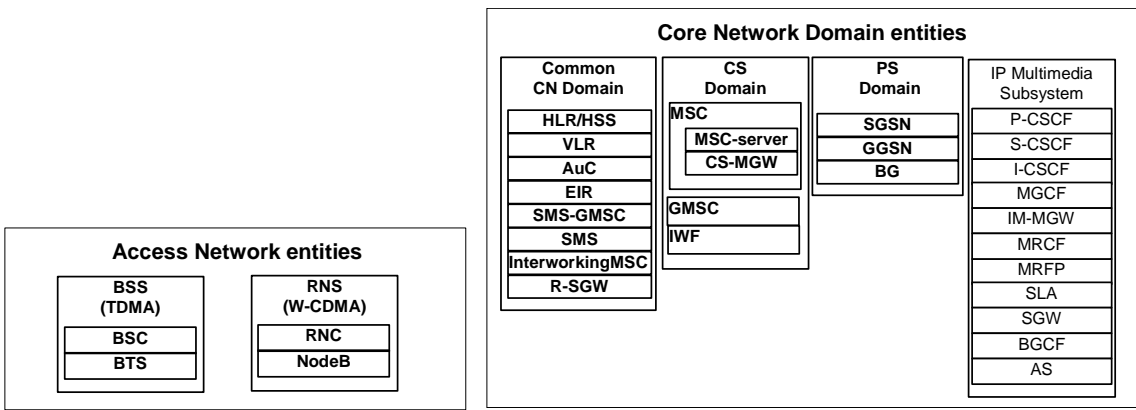

Figure 7.3a: Basic AN entities

Figure 7.3b: Basic CN entities

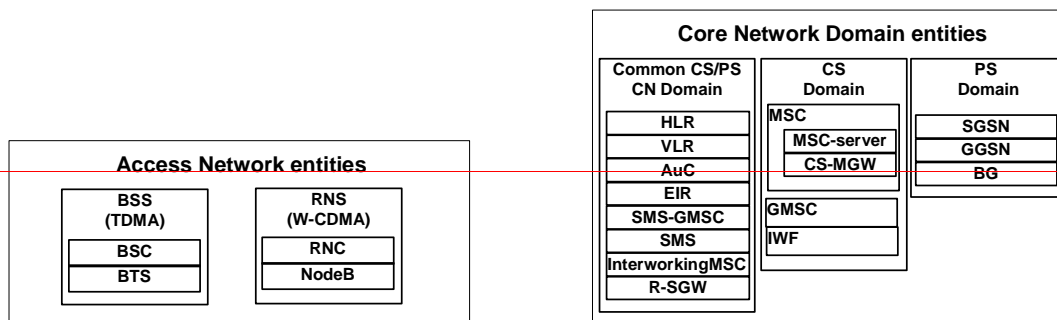
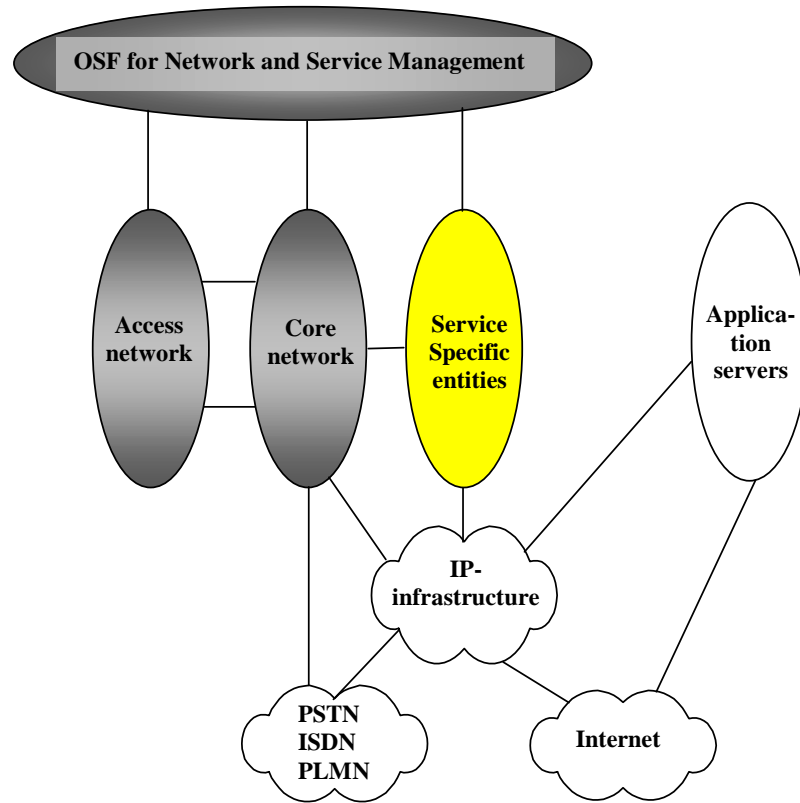

Figure 7.3a: Basic AN entities

Figure 7.3b: Basic CN entities

In figure 7.4 the prime domains for the standardisation effort of 3GPP Telecom Management are shown as shaded.



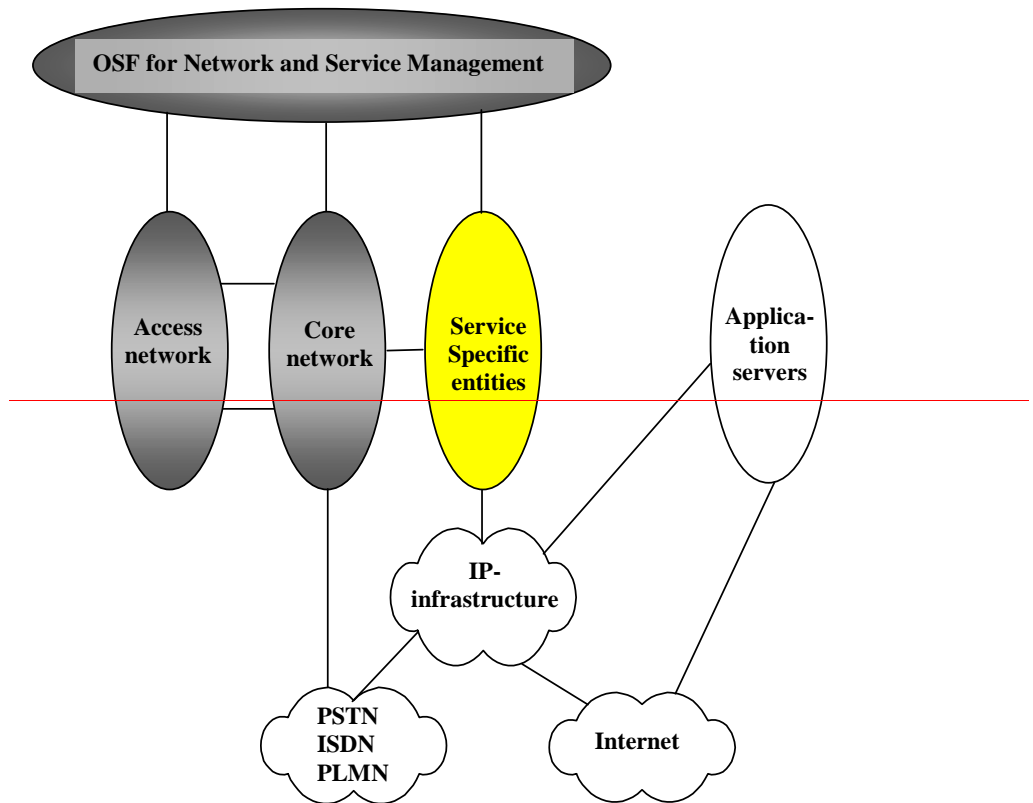

Figure 7.4 : High level UMTS Network architecture

Annex B (informative): Overview of a UMTS Network

Figure B.1 presents an example of a UMTS network, related management areas and introduces some management interfaces. UMTS Service specific entities are not shown.

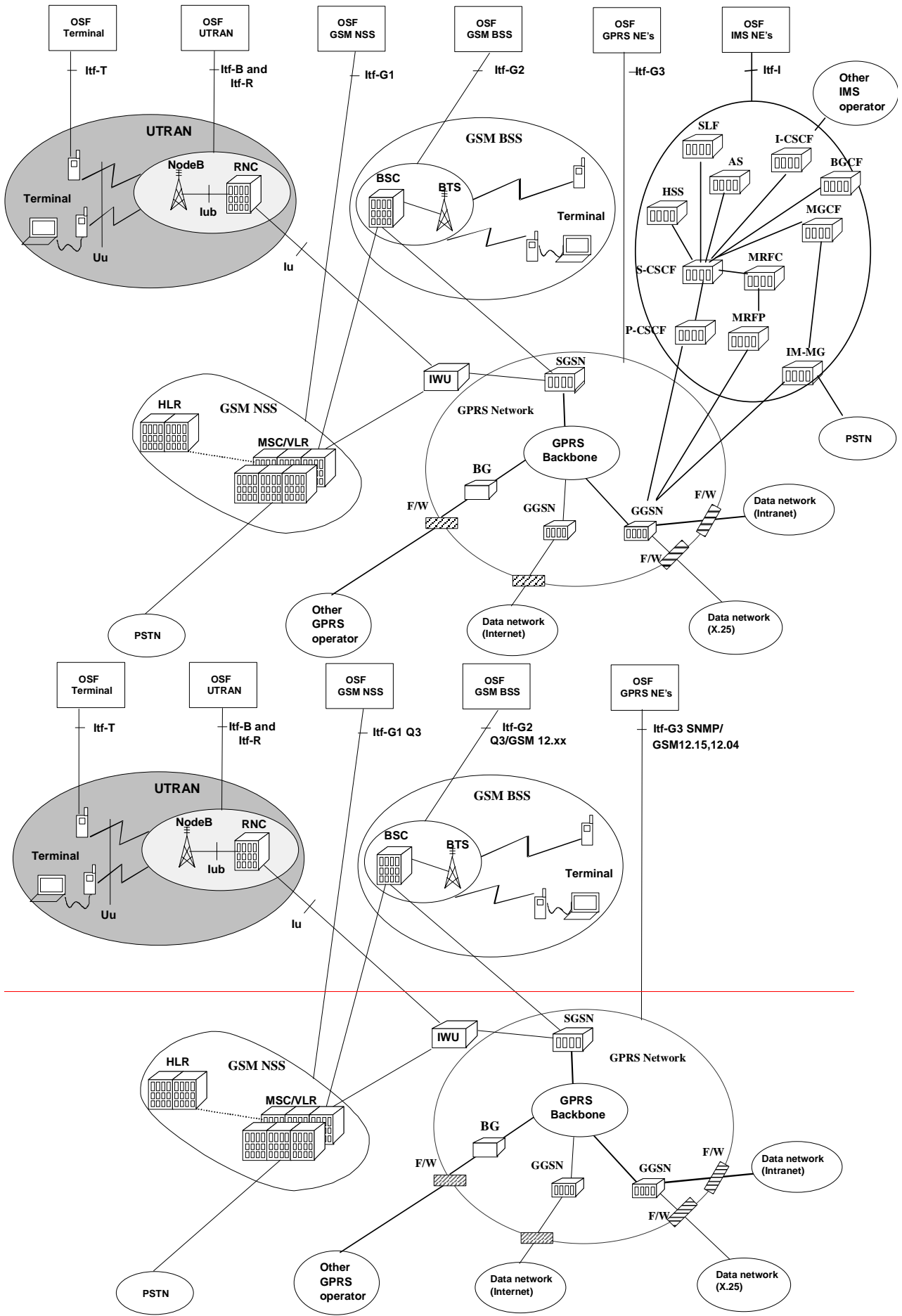

Figure B.1: Overview of a UMTS Network, showing management interfaces and management areas

All the following interfaces are illustrated in figure B.1:

- Itf-T between a terminal and a NE Manager. This interface will in some extent manage the 3G terminal and the USIM of the subscriber. Requirements of this interface are for further study.
- Itf-B and Itf-R between UTRAN and a NE Manager.
- Itf-G1 between GSM NSS and NE Manager.
- Itf-G2 between GSM BSS and NE Manager. This interface is standardised in GSM 12-series specifications.
- ~~Itf-G3 between GPRS NEs and a NE Manager. This interface is based on SNMP, GSM 12.15 (charging) and GSM 12.04 (performance management).~~
- Itf-I between the IMS and the NE manager.