

**From: TSG-CN<sup>1</sup>**

**To: TSG-SA**

**Title: Liaison Statement on Standardization/Specification of NNI (Network-to-Network Interface) standardization with Other IMT-2000 Family Member Systems**

**Document for: Discussion**

## **1. Introduction**

This liaison statement discusses an issue of NNI with other IMT-2000 Family Member Systems and clarifies some necessary preliminary steps within 3GPP TSG-SA and TSG-CN and action to outside organizations (i.e., ITU-T and 3GPP2) to start the detailed NNI specification/standardization work..

## **2. Background**

According to the GSC-4 Adhoc meeting (May 1998, Geneva), ITU-T SG11 has been proceeding the standardization for (1) UIM-MT, (2) MT-RAN, and (3) CN-CN interfaces for inter IMT-2000 family members. The figure below is extracted from ITU-T draft recommendation Q.1701 Supplement.

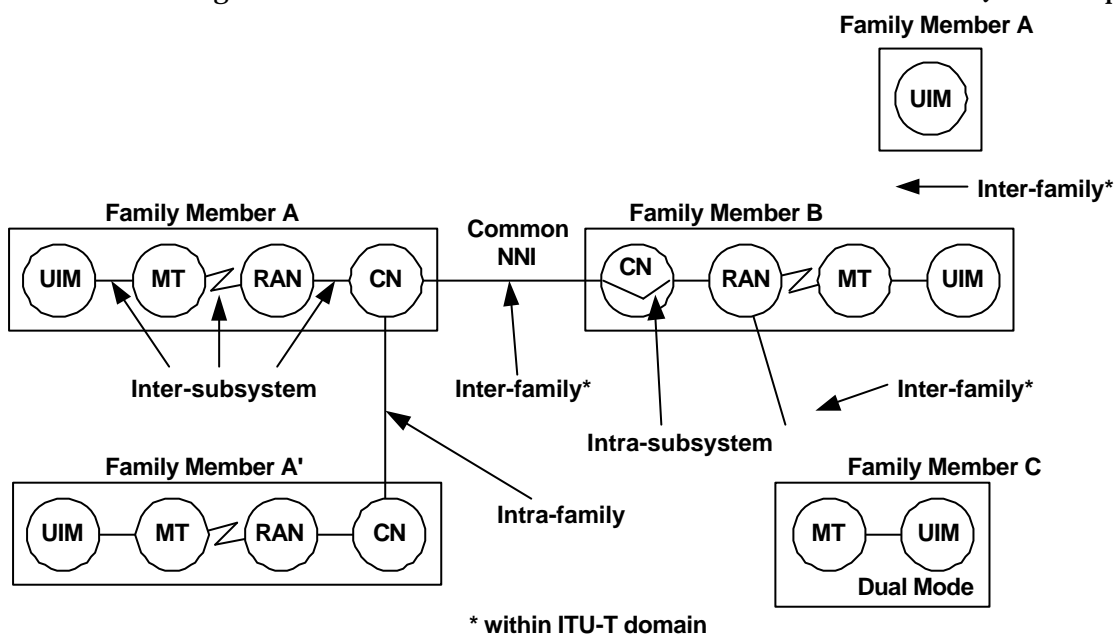

However, actual situation is as follows.

### (1) UIM-MT interface

ITU-T SG11 has already sent to 3GPP TSG-T and ETSI SMG9 a liaison stating that SMG9 should work as a center-of-excellence for UIM/IC Card standardization. ITU-T SG11 plans to terminate the work by completing a technical report "IMT-2000 Functionality and signaling requirements for UIM".

### (2) MT-RAN interface

ITU-R made a reference to 3GPP specifications/SDO standards for this interface in its recommendation IMT.RSPC. ITU-T SG11 plans to terminate the work by completing a technical report "General Requirements for IMT-2000 radio interface architecture".

### (3) NNI

ITU-T SG11 plans to standardize NNI among IMT-2000 Family Member Systems with new signaling protocols while it recognizes that different IMT-2000 Family Member Systems can be connected by installing IWF in one side.

<sup>1</sup> Masami YABUSAKI (NTTDoCoMo) e-mail:yabusaki@docomo.fr

TSG-SA has sent its position paper which implicitly objected to this NNI standardization in ITU-T SG11 (See Annex). However, it is of course rejected because ITU will normally proceed with the standardizations as far as one proponent exists.

In 3GPP, some service requirement works have been proceeded in S1 lead by Korean companies. However, the technical report "UMTS Interworking with ANSI-41 Networks". has not yet been completed. This means that 3GPP has not yet been convinced of the necessity of any specification for NNI with other IMT-2000 Family Member Systems.

Thus, ***it is silly to just criticize and object to ITU-T standardization without sufficient feasibility study.*** Instead, 3GPP TSG-SA and TSG-CN should start the necessary preliminary study for the detailed NNI specification/standardization work .

### **3. Preliminary Steps for the NNI Specification/Standardization**

In order to start the detailed NNI specification/standardization work, the following questions need to be clarified step-by-step.

#### **(1) NNI with other IMT-2000 Family Member Systems needed? (by S1)**

As mentioned below, S1 has already started some service requirement works. However, S1 should reconsider whether the market is demanding the NNI between GSM evolved CN and other IMT-2000 family CN.

#### **(2) What functions should be provided in the NNI? (by S2)**

ITU-T SG11 has already identified that NNI should at least provide mobility management, service control, call/bearer control. Any further functions?

#### **(3) New Protocol or Interworking? (by S2)**

Although TSG-SA stated in the liaison to ITU-T SG11 that it prefers interworking, it is not yet verified technically that all the functions can be implemented by interworking or not. This question is followed by:

In case that S2 concludes to make new protocol,

#### **(3-1) New protocol should be developed in ITU or between 3GPPs? (by S2 and N2)**

Even new protocol will not be unnecessarily made in ITU-T from now on. It can be made jointly with 3GPP. High level decision will be needed.

In case that S2 concludes to take interworking approach,

#### **(3-2) Specification for interworking needed? (by S2 and N2)**

Let's assume that NTTDoCoMo will interwork with any ANSI-41 network operator. In this case, interworking function can be realized by implementing GSM CN protocols within such ANSI-41 network operator or ANSI-41 CN protocols within NTTDoCoMo. Then, does 3GPP need to produce any specifications if it decides to take interworking approach?

#### **(3-2-1) Specifications on interworking should be jointly with 3GPP2? (by S2 and N2)**

Since interworking may impact on the 3GPP2 specification. The specification may have to be made jointly with 3GPP2. Relatively high judgment will be needed.

### **3. Proposal**

**TSG-CN proposes to urgently start the preliminary steps above in the relevant WGs (TSG-SA1, SA2, TSG-CN2).**

UIT - Secteur de la normalisation des télécommunications  
**ITU - Telecommunication Standardization Sector**  
**UIT - Sector de Normalización de las Telecomunicaciones**

**Study Period 1997-2000**

Commission d'études Study Group Comisión de Estudio	} <b>11</b>	Contribution tardive Delayed Contribution Contribución tardía	} <b>D.1626 - 3/11</b>
---	-------------	---	------------------------

Geneva, 22 November - 10 December 1999

**Document addressed to WP 3/11**

Texte disponible seulement en Text available only in Texto disponible solamente en	} <b>E</b>
Question(s):	8/11

SOURCE\*: ALCATEL, BT, ERICSSON, NOKIA, OMNIPOINT, SAMSUNG SIEMENS, TELIA, T-MOBIL ON BEHALF OF 3GPP TSG-SA

TITLE: 3GPP TSG-SA POSITION ON "SUPPLEMENT TO RECOMMENDATION Q.1701"

3GPP TSG SA would like to thank the Editors of the Q.1701 Supplement Proposal for their contribution. This paper has been studied and discussed intensively, and 3GPP TSG SA wants to state the following position:

The work on the 3GPP specifications for Release '99 has been progressing during the whole year 1999 and the relevant specifications have been created. The work has taken the GSM Release '98 specifications as a basis and evolved it into the current 3GPP Release '99 specifications.

We would like to make the following observations:

**MT « UIM and UIM « CN interfaces**

3GPP TSG Terminal WG3 and its 3GPP2 equivalent are already working towards a common MT ↔ UIM interface for IMT-2000. Furthermore, there is even work going on to ensure a common data structure for both 3GPP UIMs and 3GPP2 UIMs. This will lead to a common MT ↔ UIM interface fully meeting ITU-T's expectations on inter-family interfacing.

**RAN « MT interface**

This important interface has resulted in intensive negotiations and workshops having led to sound harmonization agreements among operators, manufacturers and SDOs. The technical work to turn this into reality is carried out by the cooperation of 3G Partnership Projects. Again, ITU-T's framework vision of a common RAN ↔ MT interface is being achieved.

## **CN « CN interface**

We have intensively discussed the Appendix 2 of the Q.1701 Supplement Proposal.

ITU-T considers two methods to establish interworking between core networks of IMT-2000 family members:

- (1) direct CN ↔ CN interworking
- (2) the definition of a common and unique protocol between appropriate interworking functions to any IMT-2000 family member CN protocol.

3GPP prefers the direct CN ↔ CN interface approach based on our assessment of the technical feasibility and the necessary resources and time it takes to specify and implement such kind of CN protocol. We note that there is already considerable work underway to define an evolved ANSI-41 core network and an evolved GSM MAP core network. Furthermore, strong initiatives are currently undertaken to overcome major obstacles for a mutual interworking such as different authentication mechanisms, incompatible ciphering algorithms and inconsistent packet data network architectures. We feel that these initiatives will enable global roaming in the best way achievable to meet the requirements set for the introduction of IMT-2000 networks.

## **Conclusion**

To conclude, 3GPP TSG SA is of the firm opinion that IMT-2000 can best be achieved by allowing the initiatives between family members partnership projects already begun (such as the “Hooks and Extensions” workshops, the Operators Harmonization Group and the GAIT initiative) to develop the protocols and architectures needed to fulfil the IMT-2000 framework. We feel that the role of ITU-T should be the further development of the guiding vision and evolution of the IMT-2000 family concept. This vision has already led to the effective development of detailed protocol specifications by the 3G Partnership Projects.

-----

