

Technical Specification Group Services and System Aspects Meeting #6, Nice, France, 15-17 December 1999 **TSGS#6(99)537**

Source: TSG SA WG2
Title: Coversheet for 23.002
Agenda Item: 5.2.3

Release 1999 Submission form for 23.002

Work Area / Item:		23.002 v.3.1.0			
Affects:	UE/MS:X	CN:X	UTRAN:X	Compatibility Issues:	Yes: No:X
Expected Completion Date:		March 2000 (TSG SA#7)			
Services impacted:		-			
Specifications affected:		-			
Tasks within work which are not complete:			At least the following issues are not yet covered:		
			<ul style="list-style-type: none"> • Inclusion of CAMEL aspects (already missing in 03.02 v.6 and v.7) • Inclusion of CBS aspects (already missing in 03.02 v.6 and v.7) • Update of some references, in particular to RAN TSs • possible update of terminology needed (for UE/MS) 		
Consequences if not included in Release 1999:			The complete view of the GSM/UMTS system will not be provided.		
Accepted by TSG#		for late inclusion in Release 1999:			

Abstract of document:

[This document provides the architecture of the GSM/UMTS system.](#)

Contentious Issues:

[No particular contentious issues expected.](#)

3G TS 23.002 V3.1.0 (1999-09)

Technical Specification

3rd Generation Partnership Project; Technical Specification Group Services and Systems Aspects; Network architecture (3G TS 23.002 version 3.1.0)



The present document has been developed within the 3rd Generation Partnership Project (3GPP™) and may be further elaborated for the purposes of 3GPP. The present document has not been subject to any approval process by the 3GPP Organisational Partners and shall not be implemented. This Specification is provided for future development work within 3GPP only. The Organisational Partners accept no liability for any use of this Specification. Specifications and reports for implementation of the 3GPP™ system should be obtained via the 3GPP Organisational Partners' Publications Offices.

Reference

DTS/TSGS-0223002

Keywords

Digital cellular telecommunications system,
Global System for Mobile communications (GSM)
Universal Mobile Telecommunication System
(UMTS)

3GPP

Postal address

F-06921 Sophia Antipolis Cedex - FRANCE

Office address

650 Route des Lucioles - Sophia Antipolis
Valbonne - FRANCE
Tel.: +33 4 92 94 42 00 Fax: +33 4 93 65 47 16

Internet

<http://www.3gpp.org>

Copyright Notification

No part may be reproduced except as authorized by written permission.
The copyright and the foregoing restriction extend to reproduction in all media.

© 1999, 3GPP Organizational Partners (ARIB, CWTS, ETSI, T1, TTA, TTC).
All rights reserved.

Contents

Foreword.....	5
Introduction.....	5
1 Scope.....	6
2 Normative references.....	6
3 Definitions and abbreviations.....	8
3.1 Location register.....	8
3.1.1 Home Location Register (HLR).....	8
3.1.2 Visitor Location Register (VLR).....	8
3.1.3 Serving GPRS Support Node (SGSN).....	8
3.1.4 Gateway GPRS Support Node (GGSN).....	9
3.2 Authentication Centre (AuC).....	9
3.3 Equipment Identity Register (EIR).....	9
3.4 Mobile-services Switching Centre (MSC).....	9
3.5 Border Gateway (BG).....	9
3.6 Public Land Mobile Network (PLMN).....	9
3.7 Cell.....	10
3.8 Node B.....	10
3.9 Base Station Controller (BSC) area.....	10
3.10 Radio Network Controller (RNC) area.....	10
3.11 Location Area (LA).....	10
3.12 Routing Area (RA).....	10
3.13 MSC area.....	10
3.14 GPRS Support Nodes (GSN).....	10
3.15 VLR area.....	10
3.16 SGSN area.....	11
3.17 Zones for Regional Subscription.....	11
3.18 Service area.....	11
3.19 Group call area.....	11
3.20 Group Call Register (GCR).....	11
3.21 Definitions related to Location Services (LCS).....	11
3.21.1 Serving Mobile Location Center (SMLC).....	11
3.21.2 Gateway Mobile Location Center (GMLC).....	12
3.21.3 Location Measurement Unit (LMU).....	12
3.22 Core Network (CN) and Access Network (AN).....	12
3.23 Circuit Switched (CS) and Packet Switched (PS) Domains.....	12
3.23.1 CS Domain.....	12
3.23.2 PS Domain.....	12
4 The entities of the mobile system.....	12
4.1 The Home Location Register (HLR).....	13
4.2 The Visitor Location Register (VLR).....	13
4.3 The Authentication Centre (AuC).....	14
4.4 The Equipment Identity Register (EIR).....	14
4.5 The Mobile-services Switching Centre (MSC).....	15
4.6 The Gateway MSC (GMSC).....	15
4.7 SMS Gateway MSC (SMS-GMSC).....	15
4.8 SMS Interworking MSC.....	15
4.9 The Interworking Function (IWF).....	15
4.10 The Access Network.....	15
4.10.1 The Base Station System (BSS).....	16
4.10.2 The Radio Network System (RNS).....	16
4.11 The Mobile Station (MS).....	16
4.12 The Group Call Register (GCR).....	16
4.13 Shared InterWorking Function (SIWF).....	17
4.14 Serving GPRS Support Node (SGSN).....	17

4.15	Gateway GPRS Support Node (GGSN).....	17
5	Configuration of a Public Land Mobile Network.....	18
5.1	General.....	18
5.2	Basic configuration.....	18
5.3	Basic configuration with support for LCS	20
6	PLMN interfaces.....	20
6.1	General.....	20
6.2	Interface between the MSC and the Access Network	21
6.2.1	Interface between the MSC and Base Station System (A-interface)	21
6.2.2	Interface between the MSC and RNS (Iu_CS interface)	21
6.3	Interfaces internal to the Access Network.....	21
6.3.1	Interface between BSC and BTS (Abis-interface).....	21
6.3.2	Interface between RNC and Node B (Iubis-interface).....	21
6.4	Interface between two RNCs (Iur-interface)	21
6.5	Interface between the MSC and its associated VLR (B-interface).....	21
6.6	Interface between the HLR and the MSC (C-interface)	22
6.7	Interface between the HLR and the VLR (D-interface)	22
6.8	Interface between MSCs (E-interface).....	22
6.9	Interface between MSC and EIR (F-interface).....	22
6.10	Interface between VLRs (G-interface).....	22
6.11	Interface between HLR and AuC (H-Interface)	23
6.12	Interface between Mobile Station and the Fixed Infrastructure	23
6.12.1	Interface between Mobile Station and Base Station System (Um-interface).....	23
6.12.2	Interface between Mobile Station and Radio Network System (Uu-interface).....	23
6.13	Interface between the MSC and its associated GCR (I-interface).....	23
6.14	Interface between MSC/VLR and SGSN (Gs-interface).....	23
6.15	Interface between SGSN and HLR (Gr-interface)	23
6.16	Interface between SGSN and GGSN (Gn- and Gp-interface).....	23
6.17	Interface between SGSN and the Access Network	24
6.17.1	Interface between SGSN and BSS (Gb-interface).....	24
6.17.2	Interface between SGSN and RNS (Iu_PS-interface)	24
6.18	Signalling Path between GGSN and HLR (Gc-interface).....	24
6.19	Interface between SGSN and EIR (Gf-interface).....	24
6.20	Interface between MSC and SIWFS (K-Interface) -	24
6.21	Interface between MSC and GMLC (Lg-interface)	24
6.22	Interface between MSC and SMLC (Ls-interface)	25
6.23	Interface between VLR and SMLC (Lv-interface).....	25
6.24	Interface between GMLC and HLR (Lh-interface).....	25
6.25	Interface between BTS and LMU (Um-interface)	25
7	Interface to external networks	25
7.1	Interface between the fixed networks and the MSC.....	25
7.2	Interface between GGSN and external data networks (Gi-interface).....	25
7.3	Interface between GMLC and external LCS Client (Le-interface)	25
Annex A (informative): Document change history		26
History.....		27

Foreword

This Technical Specification has been produced by the 3GPP.

The contents of the present document are subject to continuing work within the TSG and may change following formal TSG approval. Should the TSG modify the contents of this TS, it will be re-released by the TSG with an identifying change of release date and an increase in version number as follows:

Version 3.y.z

where:

x the first digit:

1 presented to TSG for information;

2 presented to TSG for approval;

3 Indicates TSG approved document under change control.

y the second digit is incremented for all changes of substance, i.e. technical enhancements, corrections, updates, etc.

z the third digit is incremented when editorial only changes have been incorporated in the specification;

Introduction

This TS present the possible architectures of the Universal Mobile Telecommunication System (UMTS) Release 99.

1 Scope

The purpose of this Technical Specification is to present the possible architectures of the mobile system. Clause 3 of this specification contains a definition of the different functional entities needed to support the mobile service. In clause 4, the configuration of a PLMN is described as well as the organisation of the functional entities; the configuration presented is the most general in order to cope with all the possible implementations which can be imagined in the different countries. To illustrate that purpose, some examples of possible configurations are presented. Clause 5 of this specification contains a brief description of the interfaces involved which shows the principle of the organisation considered.

2 Normative references

References may be made to:

- a) specific versions of publications (identified by date of publication, edition number, version number, etc.), in which case, subsequent revisions to the referenced document do not apply; or
- b) all versions up to and including the identified version (identified by “up to and including” before the version identity); or
- c) all versions subsequent to and including the identified version (identified by “onwards” following the version identity); or
- d) publications without mention of a specific version, in which case the latest version applies.

A non-specific reference to an ETS shall also be taken to refer to later versions published as an EN with the same number.

[editorial note: the replacement of the references to GSM TSs by UMTS TSs has been made according to the latest available set of UMTS TSs. The GSM TSs which should be transferred to UMTS but have not yet been transferred are marked by: "[GSM TS reference]-> TS XX.XXX "].

- [1] GSM 01.04 -> TS XX.XXX : "Digital cellular telecommunications system (Phase 2+); Abbreviations and acronyms".
- [2] TS 22.016: "Digital cellular telecommunications system (Phase 2+); International Mobile station Equipment Identities (IMEI)".
- [2a] TS 22.060: "Digital cellular telecommunications system (Phase 2+); General Packet radio Service (GPRS); Service Description; Stage 1".
- [2b] TS 22.071: "Digital cellular telecommunications system (Phase 2+); Location Services (LCS); Service Description; Stage 1".
- [3] TS 23.003: "Digital cellular telecommunications system (Phase 2+); Numbering, addressing and identification".
- [4] GSM 03.04 -> TS XX.XXX : "Digital cellular telecommunications system (Phase 2+); Signalling requirements relating to routing of calls to mobile subscribers".
- [5] TS 23.008: "Digital cellular telecommunications system (Phase 2+); Organisation of subscriber data".
- [6] TS 23.009: "Digital cellular telecommunications system (Phase 2+); Handover procedures".
- [7] TS 23.012: "Digital cellular telecommunications system (Phase 2+); Location registration procedures".
- [8] GSM 03.20 -> TS XX.XXX : "Digital cellular telecommunications system (Phase 2+); Security related network functions".

- [9] TS 23.054: "Digital cellular telecommunications system (Phase 2+); Description for the use of a Shared Inter Working Function (SIWF) in a GSM PLMN;
- [9a] TS 23.060 "Digital cellular telecommunication system (Phase 2+); General Packet Radio Service (GPRS); Service Description; Stage 2".
- [10] TS 23.068 "Digital cellular telecommunications system (Phase 2+); Voice Group Call Service (VGCS) stage 2".
- [10a] GSM 03.64 -> *TS XX.XXX* "Digital cellular telecommunication system (Phase 2+); Overall Description of the General Packet Radio Service (GPRS) Radio Interface; Stage 2".
- [10b] TS 23.071: "Digital cellular telecommunications system (Phase 2+); Location Services (LCS); Functional Description; Stage 2".
- [11] GSM 03.89 -> *TS XX.XXX* "Digital cellular telecommunications system (Phase 2+); Voice Broadcast Service (VBS) stage 2".
- [11a] TS 23.101: "General UMTS Architecture".
- [11b] TS 23.110: "Access Stratum (AS): Services and Functions".
- [12] GSM 04.02 -> *TS XX.XXX* : "Digital cellular telecommunications system (Phase 2+); GSM Public Land Mobile Network (PLMN) access reference configuration".
- [13] GSM 08.01: "Digital cellular telecommunications system (Phase 2+); Base Station System - Mobile-services Switching Centre (BSS - MSC) interface General aspects".
- [14] GSM 08.02: "Digital cellular telecommunications system (Phase 2+); Base Station System - Mobile-services Switching Centre (BSS - MSC) interface Interface principles".
- [15] GSM 08.04: "Digital cellular telecommunications system (Phase 1); Base Station System - Mobile-services Switching Centre (BSS - MSC) interface Layer 1 specification".
- [16] GSM 08.06: "Digital cellular telecommunications system (Phase 2+); Signalling transport mechanism specification for the Base Station System - Mobile-services Switching Centre (BSS - MSC) interface".
- [17] GSM 08.08: "Digital cellular telecommunications system (Phase 2+); Mobile Switching Centre - Base Station System (MSC - BSS) interface Layer 3 specification".
- [18] TS 28.020: "Digital cellular telecommunications system (Phase 2+); Rate adaption on the Base Station System - Mobile-services Switching Centre (BSS - MSC) interface".
- [19] GSM 08.51: "Digital cellular telecommunications system (Phase 2+); Base Station Controller - Base Transceiver Station (BSC - BTS) interface General aspects".
- [20] GSM 08.52: "Digital cellular telecommunications system (Phase 2+); Base Station Controller - Base Transceiver Station (BSC - BTS) interface Interface principles".
- [21] GSM 08.54: "Digital cellular telecommunications system (Phase 2+); Base Station Controller (BSC) to Base Transceiver Station (BTS) interface Layer 1 structure of physical circuits".
- [22] GSM 08.56: "Digital cellular telecommunications system (Phase 2+); Base Station Controller (BSC) to Base Transceiver Station (BTS) Layer 2 specification".
- [23] GSM 08.58: "Digital cellular telecommunications system (Phase 2+); Base Station Controller (BSC) to Base Transceiver Station (BTS) interface Layer 3 specification".
- [24] GSM 08.60: "Digital cellular telecommunications system (Phase 2+); Inband control of remote transcoders and rate adaptors".
- [25] GSM 08.61: "Digital cellular telecommunications system (Phase 2+); Inband control of remote transcoders and rate adaptors (half rate)"

- [26] TS 29.002: "Digital cellular telecommunications system (Phase 2+); Mobile Application Part (MAP) specification".
- [27] GSM 09.03 -> TS XX.XXX : "Digital cellular telecommunications system (Phase 2+); Signalling requirements on interworking between the Integrated Services Digital Network (ISDN) or Public Switched Telephone Network (PSTN) and the Public Land Mobile Network (PLMN)".
- [28] TS 29.004: "Digital cellular telecommunications system (Phase 2+); Interworking between the Public Land Mobile Network (PLMN) and the Circuit Switched Public Data Network (CSPDN)".
- [29] TS 29.005: "Digital cellular telecommunications system (Phase 2+); Interworking between the Public Land Mobile Network (PLMN) and the Packet Switched Public Data Network (PSPDN) for Packet Assembly/Disassembly facility (PAD) access".
- [30] TS 29.006: "Digital cellular telecommunications system (Phase 2+); Interworking between a Public Land Mobile Network (PLMN) and a Packet Switched Public Data Network/Integrated Services Digital Network (PSPDN/ISDN) for the support of packet switched data transmission services".
- [31] TS 29.007: "Digital cellular telecommunications system (Phase 2+); General requirements on interworking between the Public Land Mobile Network (PLMN) and the Integrated Services Digital Network (ISDN) or Public Switched Telephone Network (PSTN)".
- [32] TS 29.010: "Digital cellular telecommunications system (Phase 2+); Information element mapping between Mobile Station - Base Station System and BSS - Mobile-services Switching Centre (MS - BSS - MSC) Signalling procedures and the Mobile Application Part (MAP)".
- [33] TS 29.011: "Digital cellular telecommunications system (Phase 2+); Signalling interworking for supplementary services".

3 Definitions and abbreviations

In addition to the abbreviations given in the remainder of this clause others are listed in GSM 01.04-> TS XX.XXX .

3.1 Location register

To enable communication to a mobile station the network must know where this mobile station is located. This information is stored in a function named location register.

3.1.1 Home Location Register (HLR)

The Home Location Register (HLR) is the location register to which a mobile subscriber is assigned for record purposes such as subscriber information.

3.1.2 Visitor Location Register (VLR)

The Visitor Location Register (VLR) is the location register for Circuit Switched (CS) services, other than the HLR, used by an MSC to retrieve information for, e.g. handling of calls to or from a roaming mobile station currently located in its area.

3.1.3 Serving GPRS Support Node (SGSN)

The location register function in the SGSN stores subscription information and location information for Packet Switched (PS) services for each subscriber registered in the SGSN.

The SGSN is needed only in a PLMN which supports GPRS.

3.1.4 Gateway GPRS Support Node (GGSN)

The location register function in the GGSN stores subscription information and routing information (needed to tunnel packet data traffic destined for a GPRS MS to the SGSN where the MS is registered) for each subscriber for which the GGSN has at least one PDP context active.

The GGSN is needed only in a PLMN which supports GPRS.

3.2 Authentication Centre (AuC)

The Authentication Centre (AuC) is an entity which stores data for each mobile subscriber to allow the International Mobile Subscriber Identity (IMSI) to be authenticated and to allow communication over the radio path between the mobile station and the network to be ciphered. The AuC transmits the data needed for authentication and ciphering via the HLR to the VLR, MSC and SGSN which need to authenticate a mobile station.

The procedures used for authentication and ciphering are described more fully in GSM 03.20-> TS XX.XXX.

3.3 Equipment Identity Register (EIR)

The Equipment Identity Register (EIR) in the GSM system is the logical entity which is responsible for storing in the network the International Mobile Equipment Identities (IMEIs), used in the GSM system.

The equipment is classified as "white listed", "grey listed", "black listed" or it may be unknown as specified in TS 22.016 and TS 29.002.

3.4 Mobile-services Switching Centre (MSC)

The Mobile-services Switching Centre (MSC) constitutes the interface between the radio system and the fixed networks. The MSC performs all necessary functions in order to handle the circuit switched services to and from the mobile stations.

In order to obtain radio coverage of a given geographical area a number of base stations are normally required; i.e. each MSC would thus have to interface several base stations. In addition several MSCs may be required to cover a country.

3.5 Border Gateway (BG)

The Border Gateway (BG) is a gateway between a PLMN supporting GPRS and an external inter-PLMN backbone network used to interconnect with other PLMNs also supporting GPRS. The role of the BG is to provide the appropriate level of security to protect the PLMN and its subscribers.

The BG is only needed in PLMNs supporting GPRS.

3.6 Public Land Mobile Network (PLMN)

A Public Land Mobile Network (PLMN) is established and operated by an administration or Recognized Private Operating Agency (RPOA) for the specific purpose of providing land mobile telecommunications service services to the public. A PLMN may be regarded as an extension of a network (e.g. ISDN); it is a collection of MSCs areas within a common numbering plan (e.g. same National Destination Code) and a common routing plan. The MSCs are the functional interfaces between the fixed networks and a PLMN for call set-up.

Functionally the PLMNs may be regarded as independent telecommunications entities even though different PLMNs may be interconnected through the ISDN/PSTN and PDNs for forwarding of calls or network information. A similar type of interconnection may exist for the interaction between the MSCs of one PLMN.

3.7 Cell

[editorial note: the validity of this definition for UMTS has to be further checked]

The cell is an area of radio coverage identified by a Base station identification as defined in GSM 03.03.

3.8 Node B

A Node B is a network component which serves one cell.

3.9 Base Station Controller (BSC) area

The Base Station Controller (BSC) area is an area of radio coverage consisting of one or more cells controlled by one BSC. The boundaries of a BSC area and a location area are independent; a location area may span the boundary between BSC area and a BSC area may span the boundary between location areas.

3.10 Radio Network Controller (RNC) area

The Radio Network Controller (RNC) area is an area of radio coverage consisting of one or more cells controlled by one RNC. The boundaries of a RNC area and a location area are independent; a location area may span the boundary between RNC area and a RNC area may span the boundary between location areas.

3.11 Location Area (LA)

The Location Area (LA) is defined as an area in which a mobile station may move freely without updating the VLR. A location area may include one or several cells.

3.12 Routing Area (RA)

The Routing Area (RA) is defined as an area in which a mobile station, in certain operation modes, may move freely without updating the SGSN. A routing area may include one or several cells. A RA is always contained within a location area.

3.13 MSC area

The MSC area is the part of the network covered by an MSC. An MSC area may consist of one or several location areas. An MSC area may also consist of one or several BSC areas.

3.14 GPRS Support Nodes (GSN)

The UMTS PS-services support nodes, Gateway GSN (GGSN) and Serving GSN (SGSN) constitutes the interface between the radio system and the fixed networks for packet switched services. The GSN performs all necessary functions in order to handle the packet transmission to and from the mobile stations.

3.15 VLR area

[editorial note: the difference with the LA should be explicated]

The VLR area is the part of the network controlled by a VLR. A VLR area may consist of one or several MSC areas.

3.16 SGSN area

The SGSN area is the part of the network served by an SGSN. An SGSN area may consist of one or several routing areas. An SGSN area may also consist of one or several BSC areas. There need not be a one to one relationship between SGSN area and MSC/VLR area.

3.17 Zones for Regional Subscription

A PLMN operator may define a number of regional subscription areas, each of which is a subset of the service area for an unrestricted mobile subscriber. A regional subscription area may be contained within the service area of a single PLMN, or may lie within the service areas of two or more PLMNs. Each regional subscription area consists of one or more zones; each zone is contained within the service area of a PLMN.

The definition of a mobile subscriber's regional subscription area is stored within the HLR per National Destination Code(s) (NDC) of a PLMN and is transferred to the VLRs and/or SGSNs of that PLMN. The VLR and/or SGSN evaluates this information to extract the restricted or accessible MSC and/or SGNS areas and location areas to which the mobile subscriber is allowed to roam. The VLR and/or SGNS informs the HLR if an entire MSC and/or SGNS area is restricted.

Zones for Regional Subscription and their handling are defined in TS 23.003, TS 23.008 and TS 29.002.

3.18 Service area

The service area is defined as an area in which a mobile subscriber can be reached by another (mobile or fixed) subscriber without the subscriber's knowledge of the actual location of the mobile station within the area. A service area may consist of several PLMNs. One service area may consist of one country, be a part of a country or include several countries. The location registration system associated with each service area must thus contain a list of all mobile stations located within that service area.

3.19 Group call area

The group call area is a predefined area composed of one or a number of cells to which a particular Voice Group Call Service (VGCS) or Voice Broadcast Service (VBS) call is distributed. The composition of a group call area is predefined in the network. The group call area may include cells of more than one MSC area and cells of more than one PLMN.

3.20 Group Call Register (GCR)

The Group Call Register (GCR) is a register holding information about VGCS or VBS calls, the voice group or broadcast call attributes, respectively.

Voice group or broadcast call attributes are defined for a specific voice group or broadcast call reference and include the data required to configure the conference bridge for a VGCS or VBS call and other call related attributes.

3.21 Definitions related to Location Services (LCS)

[editorial note: the way LCS will be supported in UMTS rel.99 is still under discussion. The following definitions might not apply.]

3.21.1 Serving Mobile Location Center (SMLC)

The Serving Mobile Location Center (SMLC) node is responsible for managing the overall co-ordination and scheduling of resources required to perform positioning of a mobile, and calculating the final location estimate and accuracy. There may be more than one SMLC in a PLMN.

3.21.2 Gateway Mobile Location Center (GMLC)

The Gateway Mobile Location Center (GMLC) is the first node an external Location Application accesses in the GSM PLMN. The GMLC performs registration authorization and requests routing information from the HLR. There may be more than one GMLC in a PLMN.

3.21.3 Location Measurement Unit (LMU)

The Location Measurement Unit (LMU) gathers radio signal measurements and supplies them over the GSM air interface, via the MSC/VLR, to a particular SMLC associated with the LMU. An LMU interacts with its HLR, serving access network and MSC/VLR like a normal GSM MS, i.e. it has its own IMSI and subscription profile, and supports radio resources and mobility management functions.

3.22 Core Network (CN) and Access Network (AN)

The PLMN infrastructure is logically divided into a Core Network (CN) and an Access Network (AN), as defined in TS 23.101 and TS 23.110. The CN is logically divided into CS domain and PS domain, as defined in section "3.23 Circuit Switched (CS) and Packet Switched (PS) Domains". The AN is called BSS for GSM and RNS for UMTS, as defined in section "4.10 The Access Network".

3.23 Circuit Switched (CS) and Packet Switched (PS) Domains

The CN is constituted of a Circuit Switched (CS) domain and a Packet Switched (PS) domain. These two domains differ by the way they support user traffic, as explained below.

These two domains are overlapping, i.e. they contain some common entities. A PLMN can implement only one domain or both domains.

3.23.1 CS Domain

The CS domain refers to the set of all the CN entities offering "CS type of connection" for user traffic as well as all the entities supporting the related signalling. A "CS type of connection" is a connection for which dedicated network resources are allocated at the connection establishment and released at the connection release.

The entities specific to the CS domain are: MSC, GMSC, VLR. All the other CN entities defined in section "4 The entities of the mobile system" and not defined as PS domain specific entities (see following sub-section) are common to the CS and to the PS domains.

3.23.2 PS Domain

The PS domain refers to the set of all the CN entities offering "PS type of connection" for user traffic as well as all the entities supporting the related signalling. A "PS type of connection" transports the user information using autonomous concatenation of bits called packets: each packet can be routed independently from the previous one.

The entities specific to the PS domain are the GPRS specific entities, i.e. SGSN and GGSN. All the other CN entities defined in section "4 The entities of the mobile system" and not defined as CS domain specific entities (see previous sub-section) are common to the CS and to the PS domains.

4 The entities of the mobile system

To provide the mobile service as it is defined, it is necessary to introduce some specific functions. These functional entities can be implemented in different equipments or gathered. In any case, exchanges of data occur between these entities.

4.1 The Home Location Register (HLR)

This functional entity is a data base in charge of the management of mobile subscribers. A PLMN may contain one or several HLRs: it depends on the number of mobile subscribers, on the capacity of the equipment and on the organisation of the network. The following kinds of information are stored there:

- the subscription information;
- some location information enabling the charging and routing of calls towards the MSC where the MS is registered (e.g. the MS Roaming Number, the VLR Number, the MSC Number, the Local MS Identity).

and, if GPRS is supported, also :

- location information enabling the charging and routing of messages in the SGSN where the MS is currently registered (e.g. the SGSN Number);

and, if LCS is supported, also :

- a LCS privacy exception list, which indicates the privacy class of the MS subscriber;
- a HPLMN GMLC list.

Different types of identity are attached to each mobile subscription and are stored in the HLR. The following identities are stored:

- the International Mobile Station Identity (IMSI);
- one or more Mobile Station International ISDN number(s) (MSISDN);

if GPRS is supported, the following identity is also stored :

- zero or more Packet Data Protocol (PDP) address(es).

and, if LCS is supported, the following identity is also stored:

- the LMU indicator.

There is always at least one identity, apart from the IMSI, attached to each mobile subscription and stored in the HLR.

The IMSI or, the MSISDN may be used as a key to access the information in the database for a mobile subscription.

The data base contains other information such as:

- teleservices and bearer services subscription information;
- service restrictions (e.g. roaming limitation);
- a list of all the group IDs a service subscriber is entitled to use to establish voice group or broadcast calls;
- supplementary services; the HLR contains the parameters attached to these services;

and, if GPRS is supported, also :

- information about if a GGSN is allowed to dynamically allocate PDP addresses for a subscriber.

NOTE: Supplementary services parameters need not all be stored in the HLR. However, it seems safer to store all subscription parameters in the HLR even when some are stored in a subscriber card.

The organisation of the subscriber data is outlined in GSM 03.08.

4.2 The Visitor Location Register (VLR)

A mobile station roaming in an MSC area is controlled by the Visitor Location Register in charge of this area. When a Mobile Station (MS) enters a new location area it starts a registration procedure. The MSC in charge of that area notices this registration and transfers to the Visitor Location Register the identity of the location area where the MS is situated.

If this MS is not yet registered, the VLR and the HLR exchange information to allow the proper handling of calls involving the MS.

A VLR may be in charge of one or several MSC areas.

The VLR contains also the information needed to handle the calls set-up or received by the MSs registered in its database (for some supplementary services the VLR may have to obtain additional information from the HLR) the following elements are included:

- the International Mobile Subscriber Identity (IMSI);
- the Mobile Station International ISDN number (MSISDN);
- the Mobile Station Roaming Number (MSRN), see TS 23.003 for allocation principles;
- the Temporary Mobile Station Identity (TMSI), if applicable;
- the Local Mobile Station Identity (LMSI), if used;
- the location area where the mobile station has been registered.
- the identity of the SGSN where the MS has been registered. Only applicable to PLMNs supporting GPRS and which have a Gs interface between MSC/VLR and SGSN:
 - the last known location and the initial location of the MS;

and, if LCS is supported, the following elements for the LMUs registered in its database:

- an indication of whether the LMU was successfully registered in an associated SMLC;
- the SMLC address. The information is passed between VLR and HLR by the procedures described in TS 23.012.

The VLR also contains supplementary service parameters attached to the mobile subscriber and received from the HLR. The organisation of the subscriber data is outlined in TS 23.008.

4.3 The Authentication Centre (AuC)

The Authentication Centre (AuC) is associated with an HLR, and stores an identity key for each mobile subscriber registered with the associated HLR. This key is used to generate:

- data which are used to authenticate the International Mobile Subscriber Identity (IMSI);
- a key used to cipher communication over the radio path between the mobile station and the network.

The procedures used for authentication and ciphering are described more fully in GSM 03.20 -> TS XX.XXX.

The AuC communicates only with its associated HLR over an interface denoted the H-interface (see clause 5).

4.4 The Equipment Identity Register (EIR)

This functional entity contains one or several databases which store(s) the IMEIs used in the GSM system.

The mobile equipment may be classified as "white listed", "grey listed" and "black listed" and therefore may be stored in three separate lists.

An IMEI may also be unknown to the EIR.

An EIR shall as a minimum contain a "white list" (Equipment classified as "white listed").

4.5 The Mobile-services Switching Centre (MSC)

The Mobile-services Switching Centre is an exchange which performs all the switching and signalling functions for mobile stations located in a geographical area designated as the MSC area. The main difference between a MSC and an exchange in a fixed network is that the MSC has to take into account the impact of the allocation of radio resources and the mobile nature of the subscribers and has to perform in addition, at least the following procedures:

- procedures required for the location registration (see TS 23.012);
- procedures required for handover (see TS 23.009).

NOTE: When this improves the readability (e.g. when dealing with inter-releases handover), the term 2G-MSC can be used to refer to an MSC Release 98 or prior, and the term 3G-MSC can be used to refer to an MSC Release 99 or later.

4.6 The Gateway MSC (GMSC)

If a network delivering a call to the PLMN cannot interrogate the HLR, the call is routed to an MSC. This MSC will interrogate the appropriate HLR and then route the call to the MSC where the mobile station is located. The MSC which performs the routing function to the actual location of the MS is called the Gateway MSC (GMSC).

The acceptance of an interrogation to an HLR is the decision of the operator.

The choice of which MSCs can act as Gateway MSCs is for the operator to decide (i.e. all MSCs or some designated MSCs).

See also GSM 03.04 -> TS XX.XXX .

4.7 SMS Gateway MSC (SMS-GMSC)

The SMS Gateway MSC (SMS-GMSC) acts as an interface between a Short Message Service Centre and the PLMN, to allow short messages to be delivered to mobile stations from the Service Centre (SC).

4.8 SMS Interworking MSC

The SMS Interworking MSC acts as an interface between the PLMN and a Short Message Service Centre (SC) to allow short messages to be submitted from Mobile Stations to the SC.

4.9 The Interworking Function (IWF)

The Interworking Function (IWF) is a functional entity associated with the MSC. The IWF provides the functionality necessary to allow interworking between a PLMN and the fixed networks (ISDN, PSTN and PDNs). The functions of the IWF depend on the services and the type of fixed network. The IWF is required to convert the protocols used in the PLMN to those used in the appropriate fixed network. The IWF may have no functionality where the service implementation in the PLMN is directly compatible with that at the fixed network. The interworking functions are described in TS Technical Specifications 29.004, 29.005, 29.007 and 09.09-> TS XX.XXX .

4.10 The Access Network

Two different types of access network are used by the CN: the Base Station System (BSS) and the Radio Network System (RNS). The BSS offers a Time Division Multiple Access (TDMA) based technology to access the Mobile Station whereas the RNS offers a Wideband-Code Division Multiple Access (W-CDMA) based technology. The MSC (resp. SGSN) can connect to one of these Access Network type or to both of them.

4.10.1 The Base Station System (BSS)

The Base Station System (BSS) is the system of base station equipments (transceivers, controllers, etc...) which is viewed by the MSC through a single A-interface as being the entity responsible for communicating with Mobile Stations in a certain area. Similarly, in PLMNs supporting GPRS, the BSS also has an interface to an SGSN. The radio equipment of a BSS may support one or more cells. A BSS may consist of one or more base stations. Where an Abis-interface is implemented. The BSS consists of one Base Station Controller (BSC) and one or more Base Transceiver Station (BTS). The functionality is described in GSM 08.02.

A Base Station Controller (BSC) is a network component in the PLMN with the functions for control of one or more BTS.

A Base Transceiver Station (BTS) is a network component which serves one cell.

The split of functions between BSS and CN is described in the 08-series of GSM Technical Specifications.

4.10.2 The Radio Network System (RNS)

The Radio Network System (RNS) is the system of base station equipments (transceivers, controllers, etc...) which is viewed by the MSC through a single Iu-interface as being the entity responsible for communicating with Mobile Stations in a certain area. Similarly, in PLMNs supporting GPRS, the RNS also has an interface to a SGSN. The radio equipment of a RNS may support one or more cells. A RNS may consist of one or more base stations. The RNS consists of one Radio Network Controller (RNC) and one or more Node B. The functionality is described in [GSM 08.02 -> TS XX.XXX .

A Radio Network Controller (RNC) is a network component in the PLMN with the functions for control of one or more Node B.

A Node B is a network component which serves one cell.

The split of functions between RNS and CN is described in the 28-series of UMTS Technical Specifications.

4.11 The Mobile Station (MS)

The mobile station consists of the physical equipment used by a PLMN subscriber; it comprises the Mobile Equipment (ME) and the Subscriber Identity Module (SIM), called UMTS Subscriber Identity Module (USIM) for Release 99 and following. The ME comprises the Mobile Termination (MT) which, depending on the application and services, may support various combinations of Terminal Adapter (TA) and Terminal Equipment (TE) functional groups. These functional groups are described in GSM 04.02 > TS XX.XXX .

4.12 The Group Call Register (GCR)

The Group Call Register (GCR) shall hold for a related MSC area for each group ID and cell from which Voice Group Call Service (VGCS) or Voice Broadcast Service (VBS) calls can be established by mobile stations the voice group call reference or voice broadcast call reference to be used for a VGCS or VBS call to be established and an indication whether the originating MSC is the MSC responsible for that call.

If the originating MSC is not responsible for that call, the GCR shall hold the routing information identifying the MSC responsible for that call.

A GCR may be in charge of one or several MSC. Each MSC involved in a voice group or broadcast call requests its proper voice group or broadcast call attributes from its related GCR by use of the voice group or broadcast call reference.

The contents of each list related to requests of the MSC responsible for a voice group or broadcast call is as follows:

- a list of cells inside the MSC area of the requesting MSC into which the call is to be sent (part of the group call area);
- a list of other MSCs into which the call is to be sent;

- a list of identities of dispatchers to which a dedicated link is to be established;
- a list of identities of dispatchers which are allowed to initiate the voice group or broadcast call;
- a list of identities of dispatchers which are allowed to terminate the voice group or broadcast call;
- the length of time over which no activity is detected before the voice group call is automatically terminated;
- the default priority level related to the voice group or broadcast call if the eMLPP supplementary service applies;
- a flag indicating if acknowledgements are required for this voice group or broadcast call.

The contents of each list related to requests of an MSC not responsible for a voice group or broadcast call is as follows:

- a list of cells inside the MSC area of the requesting MSC into which the call is to be sent (part of the group call area).

More information is provided in TS 23.068 and 23.069.

4.13 Shared InterWorking Function (SIWF)

Shared InterWorking Function (SIWF) is a network function that provides interworking for data/fax calls. SIWF consists of a SIWF Controller (SIWFC) functionality located in MSCs and SIWF Server(s) (SIWFS) located in the PLMN. An SIWFS contains IWF capabilities as described in subclause 3.9. An SIWFS can be accessed by several other network nodes e. g. any MSC in the same PLMN.

More information is provided in GSM 03.54.

4.14 Serving GPRS Support Node (SGSN)

The location register function in the SGSN stores two types of subscriber data needed to handle originating and terminating packet data transfer:

- Subscription information:
 - The IMSI;
 - One or more temporary identities;
 - Zero or more PDP addresses.
- Location information:
 - Depending on the operating mode of the MS, the cell or the routing area where the MS is registered;
 - The VLR number of the associated VLR (if the Gs interface is implemented);
 - The GGSN address of each GGSN for which an active PDP context exists.

The organisation of the subscriber data in the SGSN is defined in TS 23.008 and TS 23.060.

The procedures for information transfer between the SGSN, the GGSN, the VLR and the HLR are defined in TS 23.016 and TS 23.060.

Note: When this improves the readability (e.g. when dealing with inter-releases handover), the term 2G-SGSN can be used to refer to an MSC Release 98 or prior, and the term 3G-SGSN can be used to refer to an MSC Release 99 or later.

4.15 Gateway GPRS Support Node (GGSN)

The location register function in the GGSN stores subscriber data received from the HLR and the SGSN. There are two types of subscriber data needed to handle originating and terminating packet data transfer:

- Subscription information:

- The IMSI;
- Zero or more PDP addresses.
- Location information:
 - The SGSN address for the SGSN where the MS is registered;

The organisation of the subscriber data in the GGSN is defined in TS 23.008 and TS 23.060.

The procedures for information transfer between the GGSN, the SGSN and the HLR are defined in TS 23.016 and TS 23.060.

5 Configuration of a Public Land Mobile Network

5.1 General

The basic configuration of a Public Land Mobile Network (PLMN) and the interconnection to the PSTN/ISDN is presented in figure 1. The basic configuration of a PLMN supporting GPRS and the interconnection to external PDN is presented in figures 2 and 3. This configuration presents signalling interfaces which can be found in a PLMN. Implementations may be different: some particular functions may be gathered in the same equipment and then some interfaces may become internal interfaces.

5.2 Basic configuration

In the basic configuration presented in figure 1, all the functions are considered implemented in different equipments. Therefore, all the interfaces within PLMN are external. Interfaces A and Abis are defined in the GSM 08-series of Technical Specifications. Interfaces Iu and Iubis are defined in the UMTS 28-series of Technical Specifications. Interfaces B, C, D, E, F and G need the support of the Mobile Application Part of the signalling system No. 7 to exchange the data necessary to provide the mobile service. No protocols for the H-interface and for the I-interface are standardized. All the GPRS-specific interfaces (G- series) are defined in the UMTS 23-series and 24-series of Technical Specifications.

From this configuration, all the possible PLMN organisations can be deduced. In the case when some functions are contained in the same equipment, the relevant interfaces become internal to that equipment.

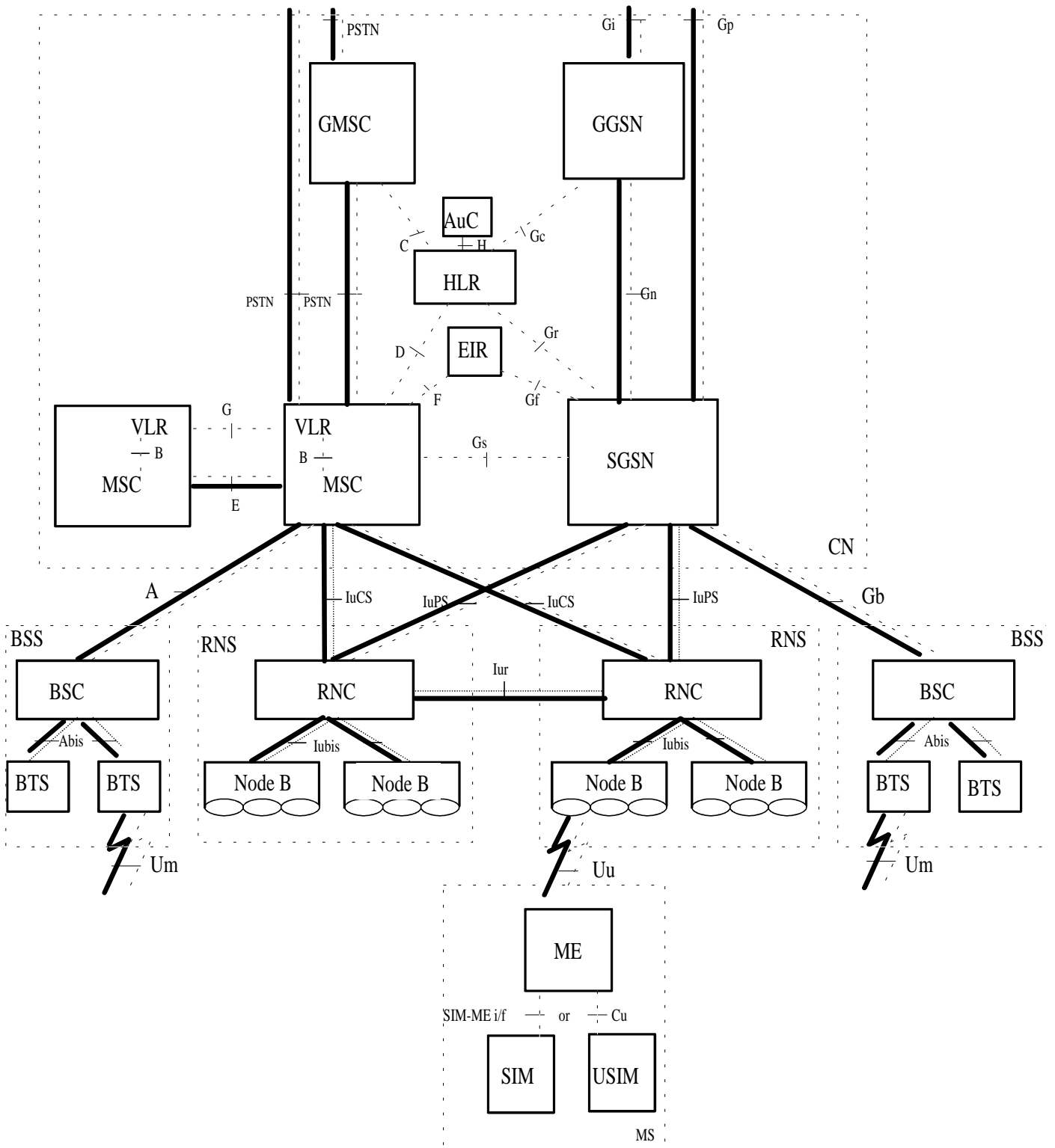

Figure 1: Configuration of a PLMN and interfaces

Legend:

Bold lines: interfaces supporting user traffic

Dashed lines: interfaces supporting signalling

NOTE 1: the figure shows direct interconnections between the entities. The actual links may be provided by an underlying network (e.g. SS7 or IP): this needs further studies.

NOTE 2: the following entities are not shown:

- the entities specific to the provisioning of Group Call (GCR)
- the entities specific to the provisioning of Location Services (shown in 5.3 Basic configuration with support for LCS)
- the entities specific to the provisioning of Short Message Services
- the other entities related to specific tasks not correctly reflected in this version of this TS, e.g. Camel Server (CS), Cell Broadcast Center (CBC), Short Message Service Center (SMSCB)

NOTE 3: when the MSC and the SGSN are integrated in a single physical entity, this entity is called UMTS MSC (UMSC).

5.3 Basic configuration with support for LCS

[editorial note: to be updated]

In the basic configuration presented in figure 4, all the functions are considered implemented in different logical nodes. If two logical nodes are implemented in the same physical equipment, the relevant interfaces may become internal to that equipment.

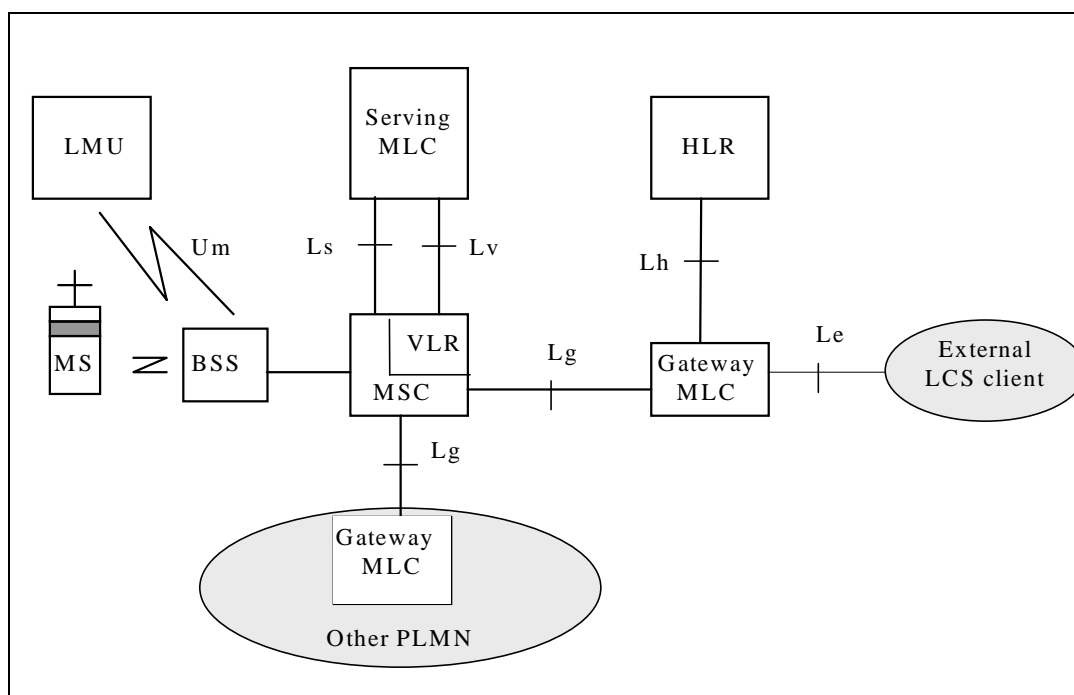

Figure 4: Configuration of a PLMN supporting LCS

6 PLMN interfaces

6.1 General

The implementation of the mobile service with international roaming implies the exchange of data between the equipment involved in the service. The same No.7 signalling network should be used to transfer these data and the call-related signalling information.

6.2 Interface between the MSC and the Access Network

6.2.1 Interface between the MSC and Base Station System (A-interface)

The interface between the MSC and its BSS is specified in the 08-series of GSM Technical Specifications.

The BSS-MSC interface is used to carry information concerning:

- BSS management;
- call handling;
- mobility management.

6.2.2 Interface between the MSC and RNS (Iu-CS interface)

The interface between the MSC and its RNS is specified in the 28-series of UMTS Technical Specifications.

The RNS-MSC interface is used to carry information concerning:

- RNS management;
- call handling;
- mobility management.

6.3 Interfaces internal to the Access Network

6.3.1 Interface between BSC and BTS (Abis-interface)

When the BSS consists of a Base Station Controller (BSC) and one or more Base Transceiver Stations (BTS), this interface is used between the BSC and BTS to support the services offered to the GSM users and subscribers.

The interface also allows control of the radio equipment and radio frequency allocation in the BTS.

The interface is specified in the 08.5x-series of GSM Technical Specifications.

6.3.2 Interface between RNC and Node B (Iubis-interface)

When the RNS consists of a Base Station Controller (RNC) and one or more Base Transceiver Stations (BTS), this interface is used between the RNC and BTS to support the services offered to the GSM users and subscribers.

The interface also allows control of the radio equipment and radio frequency allocation in the BTS.

The interface is specified in the 28.5x-series of GSM Technical Specifications.

6.4 Interface between two RNCs (Iur-interface)

[to be completed]

6.5 Interface between the MSC and its associated VLR (B-interface)

The VLR is the location and management data base for the mobile subscribers roaming in the area controlled by the associated MSC(s). Whenever the MSC needs data related to a given mobile station currently located in its area, it interrogates the VLR. When a mobile station initiates a location updating procedure with an MSC, the MSC informs its VLR which stores the relevant information. This procedure occurs whenever an MS roams to another location area.

Also, when a subscriber activates a specific supplementary service or modifies some data attached to a service, the MSC informs (via the VLR) the HLR which stores these modifications and updates the VLR if required.

This interface is internal to the MSC/VLR; signalling on it is not standardised.

6.6 Interface between the HLR and the MSC (C-interface)

The Gateway MSC must interrogate the HLR of the required subscriber to obtain routing information for a call or a short message directed to that subscriber.

Signalling on this interface uses the Mobile Application Part (MAP), which in turn uses the services of Transaction Capabilities. See TS 29.002.

6.7 Interface between the HLR and the VLR (D-interface)

This interface is used to exchange the data related to the location of the mobile station and to the management of the subscriber. The main service provided to the mobile subscriber is the capability to set up or to receive calls within the whole service area. To support this, the location registers have to exchange data. The VLR informs the HLR of the location of a mobile station managed by the latter and provides it (either at location updating or at call set-up) with the roaming number of that station. The HLR sends to the VLR all the data needed to support the service to the mobile subscriber. The HLR then instructs the previous VLR to cancel the location registration of this subscriber. Exchanges of data may occur when the mobile subscriber requires a particular service, when he wants to change some data attached to his subscription or when some parameters of the subscription are modified by administrative means.

Signalling on this interface uses the Mobile Application Part (MAP), which in turn uses the services of Transaction Capabilities. See TS 29.002.

6.8 Interface between MSCs (E-interface)

When a mobile station moves from one MSC area to another during a call, a handover procedure has to be performed in order to continue the communication. For that purpose the MSCs have to exchange data to initiate and then to realise the operation.

After the handover operation has been completed, the MSCs will exchange information to transfer A-interface signalling as necessary.

When a short message is to be transferred between a Mobile Station and Short Message Service Centre (SC), in either direction, this interface is used to transfer the message between the MSC serving the Mobile Station and the MSC which acts as the interface to the SC.

Signalling on this interface uses the Mobile Application Part (MAP), which in turn uses the services of Transaction Capabilities. See TS 29.002.

6.9 Interface between MSC and EIR (F-interface)

This interface is used between MSC and EIR to exchange data, in order that the EIR can verify the status of the IMEI retrieved from the Mobile Station.

Signalling on this interface uses the Mobile Application Part (MAP), which in turn uses the services of Transaction Capabilities. See TS 29.002.

6.10 Interface between VLRs (G-interface)

When a mobile subscriber moves from a VLR area to another Location Registration procedure will happen. This procedure may include the retrieval of the IMSI and authentication parameters from the old VLR.

Signalling on this interface uses the Mobile Application Part (MAP), which in turn uses the services of Transaction Capabilities. See GSM 09.02.

6.11 Interface between HLR and AuC (H-Interface)

When an HLR receives a request for authentication and ciphering data for a Mobile Subscriber and it does not hold the requested data, the HLR requests the data from the AuC. The protocol used to transfer the data over this interface is not standardised.

6.12 Interface between Mobile Station and the Fixed Infrastructure

6.12.1 Interface between Mobile Station and Base Station System (Um-interface)

The interface between the MS and the BSS is specified in the 04- and 05-series of GSM Technical Specifications.

6.12.2 Interface between Mobile Station and Radio Network System (Uu-interface)

The interface between the MS and the RNS is specified in the 24- and 25-series of UMTS Technical Specifications.

6.13 Interface between the MSC and its associated GCR (I-interface)

The GCR is the management data base for the voice group or broadcast calls in the area controlled by the associated MSC(s). Whenever the MSC needs data related to a requested voice group or broadcast call it interrogates the GCR to obtain the respective voice group or broadcast call attributes. The protocol used to transfer the data over this interface is not standardized.

6.14 Interface between MSC/VLR and SGSN (Gs-interface)

The SGSN may send location information to the MSC/VLR via the optional Gs interface. The SGSN may receive paging requests from the MSC/VLR via the Gs interface. The MSC/VLR may indicate to an SGSN, via the Gs interface, that an MS is engaged in a service handled by the MSC.

Signalling on this interface uses connectionless SCCP (without TCAP). SCCP Global Title (GT) is used for addressing. The Gs-interface is defined in TS 29.016 and 29.018.

6.15 Interface between SGSN and HLR (Gr-interface)

This interface is used to exchange the data related to the location of the mobile station and to the management of the subscriber. The main service provided to the mobile subscriber is the capability to transfer packet data within the whole service area. The SGSN informs the HLR of the location of a mobile station managed by the latter. The HLR sends to the SGSN all the data needed to support the service to the mobile subscriber. Exchanges of data may occur when the mobile subscriber requires a particular service, when he wants to change some data attached to his subscription or when some parameters of the subscription are modified by administrative means.

Signalling on this interface uses the Mobile Application Part (MAP), which in turn uses the services of Transaction Capabilities (TCAP). See TS 29.002.

6.16 Interface between SGSN and GGSN (Gn- and Gp-interface)

These interfaces are used to support mobility between the SGSN and GGSN. The Gn interface is used when GGSN and SGSN are located inside one PLMN. The Gp-interface is used if GGSN and SGSN are located in different PLMNs. The

Gn/Gp interface also includes a part which allows SGSNs to communicate subscriber and user data, when changing SGSN.

Signalling on this interface uses the User Datagram Protocol, UDP/IP. The Gn/Gp interface is defined in TS 29.060.

6.17 Interface between SGSN and the Access Network

6.17.1 Interface between SGSN and BSS (Gb-interface)

The BSS-SGSN interface is used to carry information concerning:

- packet data transmission;
- mobility management.

The Gb interface is defined in GSM 08.14, 08.16 and 08.18.

6.17.2 Interface between SGSN and RNS (Iu_PS-interface)

The RNS-3G-SGSN interface is used to carry information concerning:

- packet data transmission;
- mobility management.

The Iu_PS interface is defined in *TS XX.XXX* , *TS XX.XXX* and *TS XX.XXX* .

6.18 Signalling Path between GGSN and HLR (Gc-interface)

This optional signalling path may be used by the GGSN to retrieve information about the location and supported services for the mobile subscriber, to be able to activate a packet data network address.

There are two alternative ways to implement this signalling path:

- if an SS7 interface is implemented in the GGSN, signalling between the GGSN and the HLR uses the Mobile Application Part (MAP), which in turn uses the services of Transaction Capabilities (TCAP). See GSM 09.02;
- if there is *no* SS7 interface in the GGSN, any GSN in the same PLMN and which has an SS7 interface installed can be used as a GTP to MAP protocol converter, thus forming a signalling path between the GGSN and the HLR.

6.19 Interface between SGSN and EIR (Gf-interface)

This interface is used between SGSN and EIR to exchange data, in order that the EIR can verify the status of the IMEI retrieved from the Mobile Station.

Signalling on this interface uses the Mobile Application Part (MAP), which in turn uses the services of Transaction Capabilities (TCAP). See GSM 09.02.

6.20 Interface between MSC and SIWFS (K-Interface) -

The K interface is used between MSC and SIWFS and is specified in GSM Technical specification 03.54.

6.21 Interface between MSC and GMLC (Lg-interface)

The MSC -GMLC interface is used to exchange data needed by the MSC to perform subscriber authorization and allocate network resources. The GMLC provides the IMSI and requested Quality of Service information.

Signalling on this interface uses the Mobile Application Part (MAP), which in turn uses the services of Transaction Capabilities (TCAP). See TS 29.002.

6.22 Interface between MSC and SMLC (Ls-interface)

The MSC -SMLC interface is used to exchange data needed by the SMLC to select a positioning method and compute a location estimate. The MSC provides the MS's location capabilities and requested Quality of Service information.

Signalling on this interface uses the Mobile Application Part (MAP), which in turn uses the services of Transaction Capabilities (TCAP). See TS 29.002.

6.23 Interface between VLR and SMLC (Lv-interface)

The VLR-SMLC interface is used to support transferring of registration and deregistration information between the VLR and SMLC.

Signalling on this interface uses the Mobile Application Part (MAP), which in turn uses the services of Transaction Capabilities (TCAP). See TS 29.002.

6.24 Interface between GMLC and HLR (Lh-interface)

This interface is used by the GMLC to retrieve the VMSC location and IMSI for a particular mobile.

Signalling on this interface uses the Mobile Application Part (MAP), which in turn uses the services of Transaction Capabilities (TCAP). See TS 29.002.

6.25 Interface between BTS and LMU (Um-interface)

The Um interface specific to LCS is defined in 24.071.

7 Interface to external networks

The interfaces with fixed networks, including dedicated networks, are described in the 09-series of GSM Technical Specifications and in the 29-series of TS Technical Specification.

7.1 Interface between the fixed networks and the MSC

The MSC is based on a normal ISDN exchange. It has, for call control, the same interface as the fixed network exchanges. The signalling interface considered in the GSM Technical Specifications is related to the signalling system No. 7 User Parts TUP and ISUP associated to the circuits used for incoming and outgoing calls.

7.2 Interface between GGSN and external data networks (Gi-interface)

This interface connects the PLMN to external public or private packet data networks.

7.3 Interface between GMLC and external LCS Client (Le-interface)

This interface connects the PLMN to the external LCS Client.

Annex A (informative): Document change history

Status of TS 23.002		
Date	Version	Information about changes
September 1999	23.002 version 3.0.0	renumbering of this TS from 03.02 to 23.002 (23.002 v.3.0.0 identical to 03.02 v.7.0.0)
October 1999	23.002 version 3.1.0	widely modified to incorporate UMTS

History

Document history		
V3.0.0	September 1999	identical to 03.02 v.7.0.0
v3.1.0	October 1999	widely modified to incorporate UMTS aspects