

**TSG-RAN Working Group 3 meeting #4**  
**Warwick, UK, 1st - 4<sup>th</sup> June 1999**

*TSGR3#4(99)468*

**Agenda Item:** 16.2  
**Source:** Vodafone  
**Title:** Proposed changes to 25.433: NBAP Specification V1.0.1  
**Document for:** Decision

---

**3GPP**

# TS RAN 25.433 V1.0.1 (1999-06)

---

*Technical Specification*

**3<sup>rd</sup> Generation Partnership Project (3GPP);  
Technical Specification Group (TSG) RAN  
NBAP Specification**

**[UMTS <spec>]**

---

**3GPP**

Reference

---

<Workitem> (<Shortfilename>.PDF)

Keywords

---

<keyword[, keyword]>

**3GPP**

Postal address

---

Office address

---

Internet

---

[secretariat@3gpp.org](mailto:secretariat@3gpp.org)

Individual copies of this deliverable  
can be downloaded from

<http://www.3gpp.org>

---

**Copyright Notification**

---

No part may be reproduced except as authorized by written permission.  
The copyright and the foregoing restriction extend to reproduction in all media.

©  
All rights reserved.

---

# Contents

Intellectual Property Rights .....	<a href="#">554</a>
Foreword .....	<a href="#">554</a>
1 Scope .....	<a href="#">554</a>
2 References .....	<a href="#">554</a>
3 Definitions, symbols and abbreviations .....	<a href="#">554</a>
3.1 Definitions.....	<a href="#">554</a>
3.2 Symbols.....	<a href="#">664</a>
3.3 Abbreviations .....	<a href="#">664</a>
4 General.....	<a href="#">664</a>
5 NBAP Services .....	<a href="#">774</a>
6 Services expected from signalling transport.....	<a href="#">774</a>
7 Functions of NBAP .....	<a href="#">774</a>
8 Elementary NBAP procedures.....	<a href="#">884</a>
9 Elements for NBAP communication .....	<a href="#">20204</a>
9.1 Message functional definition and content.....	<a href="#">20204</a>
9.2 Message format and information element coding .....	<a href="#">26274</a>
9.3 Timers .....	<a href="#">39394</a>
10 Handling of unknown, unforeseen and erroneous protocol data.....	<a href="#">39394</a>
11 Annex A (normative):.....	<a href="#">39394</a>
12 History .....	<a href="#">40404</a>

---

# Intellectual Property Rights

## Foreword

This Technical Specification has been produced by the 3<sup>rd</sup> Generation Partnership Project, Technical Specification Group <TSG name>.

The contents of this TS may be subject to continuing work within the 3GPP and may change following formal TSG approval. Should the TSG modify the contents of this TS, it will be re-released with an identifying change of release date and an increase in version number as follows:

Version m.t.e

where:

- m indicates [major version number]
- x the second digit is incremented for all changes of substance, i.e. technical enhancements, corrections, updates, etc.
- y the third digit is incremented when editorial only changes have been incorporated into the specification.

---

## 4 Scope

The present document specifies the standards for NBAP specification to be used over Iub Interface.

---

## 2 References

The following documents contain provisions which, through reference in this text, constitute provisions of the present document.

- References are either specific (identified by date of publication, edition number, version number, etc.) or non-specific.
- For a specific reference, subsequent revisions do not apply.
- For a non-specific reference, the latest version applies.
- A non-specific reference to an ETS shall also be taken to refer to later versions published as an EN with the same number.

[1] [25.401, UTRAN Overall Description](#)

[2]

---

## 3 Definitions, symbols and abbreviations

### 3.1 Definitions

*NBAP (Node B Application Part) is defined as Radio Network Layer Protocol applied the interface between Controlling RNC and NodeB, namely Iub Interface.*

## 3.2 Symbols

## 3.3 Abbreviations

AAL2	ATM Adaptation Layer type 2
ASN.1	Abstract Syntax Notation One
ATM	Asynchronous Transfer Mode
BCCH	Broadcast Control Channel
CCPCH	Common Control Physical Channel
CFN	Connection Frame Number
CRNC	Controlling Radio Network Controller
DCH	Dedicated Channel
DL	Downlink
DPCCCH	Dedicated Physical Control Channel
DPCH	Dedicated Physical Channel
DPDCH	Dedicated Physical Data Channel
DRNC	Drift Radio Network Controller
FDD	Frequency Division Duplex
FP	Frame Protocol
L1	Layer 1
L2	Layer 2
NBAP	Node B Application Part
OFF	Frame Offset
O&M	Operation and Management
<del>OMC-B</del>	
QoS	Quality of Service
RL	Radio Link
RNC	Radio Network Controller
RRC	Radio Resource Control
SRNC	Serving Radio Network Controller
TDD	Time Division Duplex
TFC	Transport Format Combination
TFCI	Transport Format Combination Indicator
TFCS	Transport Format Combination Set
TFS	Transport Format Set
UE	User Equipment
UL	Uplink
UTRAN	UMTS Terrestrial Radio Access Network

---

## 4 General

*[Editor's note: This chapter should describe requirements on protocol capabilities, principles, etc.]*

Node B Application Part, NBAP, includes common procedures and dedicated procedures. It covers procedures for paging distribution, broadcast system information, request / complete / release of dedicated resources and management of logical resources ([logical O&M \[1\]](#)).

Note that the issue of transport layer addressing is FFS.

---

## 5 NBAP Services

The NBAP offers the following services:

---

## 6 Services expected from signalling transport

---

## 7 Functions of NBAP

The following messages belong to NBAP protocol.

- Measurement Request
- Measurement Request Accept
- Measurement Request Reject
- Measurement Termination
- Measurement Report
- System Information Update
- Radio Link Setup
- Radio Link Setup Response
- Radio Link Setup Failure
- Radio Link Addition
- Radio Link Addition Response
- Radio Link Addition Failure
- Radio Link Reconfiguration Prepare
- Radio Link Reconfiguration Ready
- Radio Link Reconfiguration Commit
- Radio Link Reconfiguration Failure
- Radio Link Reconfiguration Cancel
- Radio Link Reconfiguration
- Radio Link Reconfiguration Response
- Radio Link Deletion
- Radio Link Deletion Response
- Power Control

---

## 8 Elementary NBAP procedures

NBAP procedures are divided into common procedures and dedicated procedures.

- NBAP common procedures are procedures that request initiation of a UE context for a specific UE in Node B or are not related to a specific UE. NBAP common procedures also incorporate logical O&M [1] procedures.
- NBAP dedicated procedures are procedures that are related to a specific UE context in Node B. This UE context is identified by a UE context identity.

The two types of procedures may be carried on separate signalling links.

### 8.1 NBAP Common Procedures

Note: Logical O&M Procedures will be included in this chapter.

Editor's Note: This section is not stable

#### 8.1.1 Common Channels Management

This procedure provides the capability to activate common channel resources such as [cell broadcast channels and] random access channels. The ability to control, for example, paging retransmission should also be provided. Information on common channel performance (eg overload) should be provided by node B to the RNC. Any failures impacting on the common channel resources at Node B should be signalled to the RNC via the Resource Event Management procedure (section 8.1.6).

#### 8.1.2 Radio ~~Resource~~ System Equipment Management

Where parameters relating to configuration of the Radio System Equipment are part of the cell logical model (i.e. channel frequency and transmission power), their transfer will be supported by the Cell Configuration Management procedure (section 8.1.5). Other Radio System Equipment Management functions will be supported via Implementation Specific O&M [1]. If failures in the radio system equipment impact on the logical resources (or redundancy of such resources) at Node B, this should be signalled to the RNC via the Resource Event Management procedure (section 8.1.6). This procedure controls the physical radio system, eg transmitter tuning and output power control functions. Procedures [will], for example, also provide for the RNC to be informed of the automatic reconfiguration of node B in the case of partial failures and the availability of redundant radio equipment.

#### 8.1.3 Iub ~~Signalling Bearer~~ Link Termination and Management

This procedure shall deal with the management of the Iub link. This will address not only initial link establishment, but also the ongoing monitoring of link health, link recovery, load sharing and distribution.

#### Performance Monitoring (Real Time)

#### 8.1.4 Measurement Request

For requesting measurements, the RNC use the following procedure:



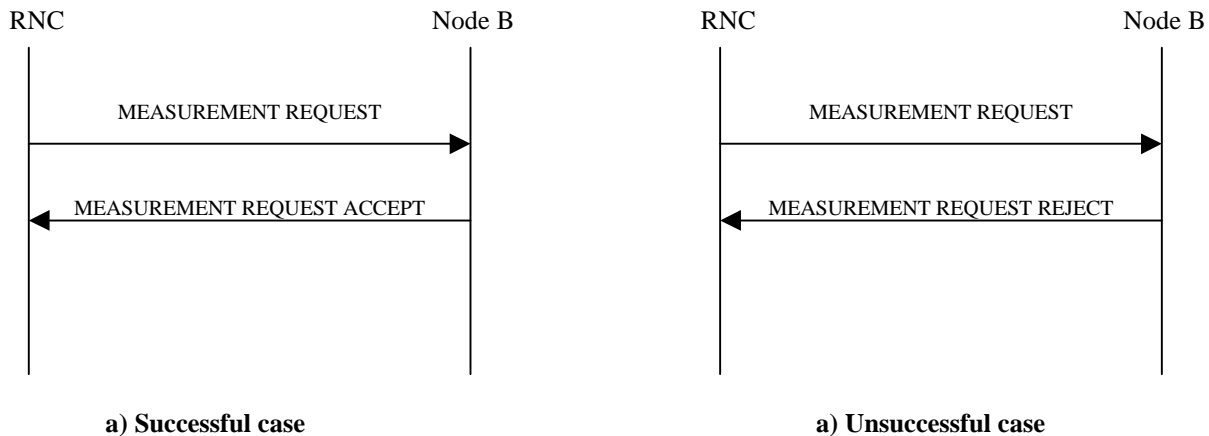

### Measurement Request Procedure

The MEASUREMENT REQUEST message includes the following information:

- **Measurement Id:** This is a RNC defined identifier that uniquely identifies the measurement.
- **Measurement Object:** This defines on which resource the measurement should be performed. For example might this identifier point out a cell or a carrier within the Node B.
- **Measurement Type:** This defines what measurement that should be performed. This could for example be “interference on the uplink” or “used power on the downlink”.
- **Measurement Characteristics:** This defines how the measurements should be performed. For example measurement frequency, timing information, filtering information. *The exact structure and contents of this parameter is dependent on the Measurement Type and is FFS.*
- **Report Characteristics:** The reporting could be any of the following classes:
  - ◆ **Periodic:** Reports should be delivered in a periodic matter with some frequency. In this case the update frequency have to be specified.
  - ◆ **Event Triggered:** Reports should be delivered upon a specific event in Node B. In this case the event have to be specified.
  - ◆ **Immediate Reporting:** A report should be delivered immediately. Only one measurement report should be sent and after that the measurement is automatically cancelled.

*The possibility to request several measurements for the same event is FFS.*

The MEASUREMENT REQUEST ACCEPT message is used to accept a requested measurement and it includes the following information:

- **Measurement Id:** This is the same Id that was used in the request.

The MEASUREMENT REQUEST REJECT message is used to reject a requested measurement and it includes the following information:

- **Measurement Id:** This is the same Id that was used in the request.
- **Cause:** This states the cause for the reject. *The exact content of this parameter is FFS.*

### 8.1.5 Measurement Termination initiated by RNC

For termination of previously requested measurements, the RNC use the following procedure:

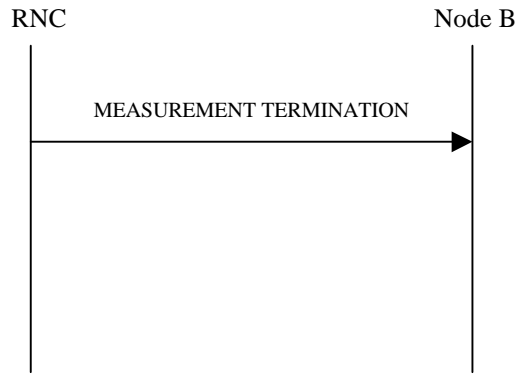

**Measurement Termination Procedure initiated by RNC**

The MEASUREMENT TERMINATION message includes the following information:

- **Measurement Id:** This is the same Id that was used in the request.

**8.1.6 Measurement Termination initiated by NodeB**

For termination of previously requested measurements from NodeB, the NodeB use the following procedure:

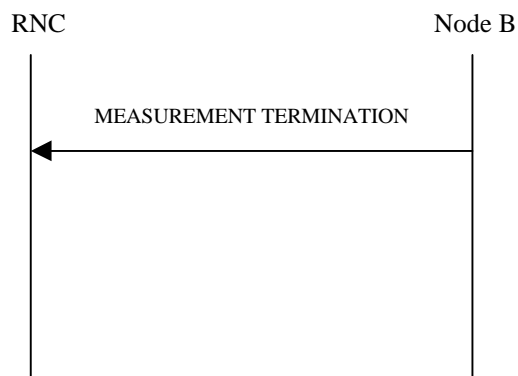

**Measurement Termination Procedure initiated by NodeB**

The MEASUREMENT TERMINATION message includes the following information:

- **Measurement Id:** This is the same Id that was used in the request.

**8.1.7 Measurement Report**

To report a previously requested measurement, Node B uses the following procedure:

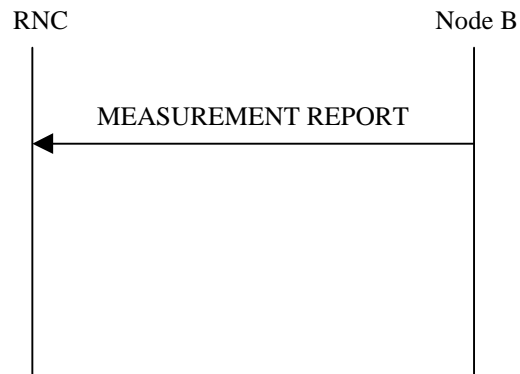

### Measurement Report Procedure

The MEASUREMENT REPORT message includes the following information:

- **Measurement Id:** This is the same id that was used in the request.
- **Time Reference:** This is a time reference showing the time of the measurement. *The accuracy of this is FFS.*
- **Value**

*The possibilities for including several values and/or several measurements in the same report are FFS.*

## 8.1.8 Cell Configuration Management

This procedure provides the means for the RNC to configure ~~some of~~ the cell related parameters of the node B, and also the means for the node B to transfer the values of these and other parameters back to the RNC. Examples are: RF parameters, system information parameters and, channel configuration data. The overall Cell Configuration Management procedure should support a set of individual procedures which allow specific areas of the cell configuration to be updated independently. This will reduce the signalling on the Iub in the case where individual parameters need to be updated.

The following procedures should form part of the overall Cell Configuration Management procedure (the inclusion of further procedures is FFS).

### System Information Update Procedure

This NBAP common procedure is used by the CRNC to send system information to its Node B, which broadcasts them on the logical channel BCCH. The procedure is triggered when CRNC sets the system information at start/restart and when the system information needs to be modified.

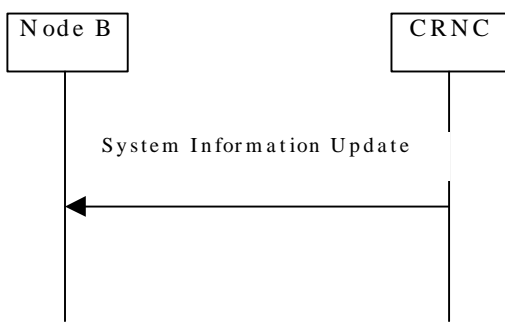

### 8.1.9 Notification of Available Logical Resources Resource Event Management

When the resources of node B which are available to the RNC change (eg due to failures within Node B or due to interactions with ~~OMC-B management system~~), this procedure provides the means to inform the RNC of this change and/or to warn the RNC of the impending change. In the case of the latter, the procedure should support the ability for the RNC to authorise such changes, (e.g. in the case where the management system wishes to perform service affecting routine operations, the RNC should be provided with the ability to ability to reject these dependent on the traffic conditions).

Where events at Node B occur on implementation specific entities within it, but the result is a possible impact on the logical resources of Node B, the Resource Event Management procedure shall be used to indicate this impact to the RNC. Any such impact on logical resources should include both total loss and performance degradation (for example fault such as receiver sensitivity reduction). Scenarios anticipated to trigger such a situation include:

- Timing and synchronisation errors in Node B
- Loss of the Implementation Specific O&M link [1]
- Radio System Equipment events (see section 8.1.2)
- Node B common equipment events
- Maintenance procedures (either internal to Node B or initiated from the management system)

### 8.1.10 System Information Update Procedure

~~This NBAP common procedure is used by the CRNC to send system information to its Node B, which broadcasts them on the logical channel BCCH. The procedure is triggered when CRNC sets the system information at start/restart and when the system information needs to be modified.~~

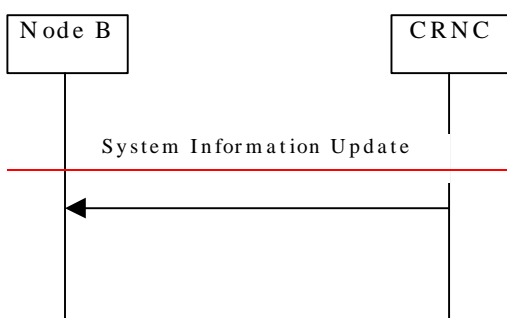

### Node B Initialisation and Software Management

This procedure will allow for the RNC to be involved in the management of software downloads and initialisation of Node B, in the case where these processes impact on the logical resources at Node B. For software download, the procedure shall support RNC and management system co-ordination for the control of the process. The Iub shall not support the actual transfer of software. The procedure should include co-ordination between the RNC and management system for the activation of new software, incorporating notification of any possible resource impact.

Similarly, the procedure shall allow for co-ordination between the RNC and management system for Node B initialisation and resets. The procedure should support Node B resets originated from both the RNC and management system.

## 8.1.11 Radio Link Setup

This NBAP common procedure is used when there is no Radio Link for this UE in the Node B.

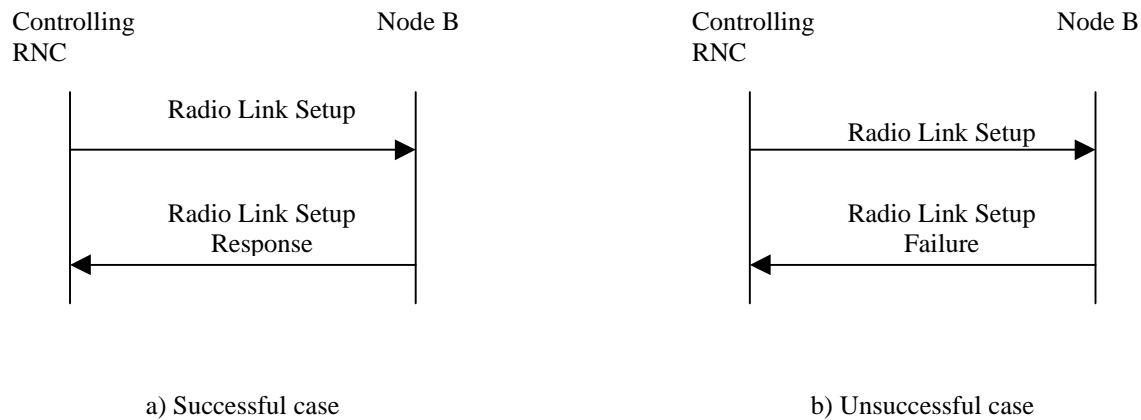

The RADIO LINK SETUP message contains the following information (the identification of the UE is FFS):

- UL Radio Resource (UL Scrambling Code, UL Channelisation Code)
- DL Radio Resource (DL Channelisation Codes per Radio Link, DL Scrambling Code is FFS)
- DCH Information (DCH Identifier, Transmission Rate, Transport Format Set) (for each DCH in the UE)
- Transport Format Combination Set
- Power control information
- Frequency
- RL identifier #1
- Target cell identifier #
- RL identifier #2
- Target cell identifier #
- Soft combining indication (may, must, or must not be combined with already existing radio links)
- .....
- RL identifier #n
- Target cell identifier #
- Soft combining indication (may, must, or must not be combined with already existing radio links)

The RADIO LINK SETUP RESPONSE message contains

- Transport layer addressing information (AAL2 address) per RL

## 8.2 NBAP Dedicated Procedures

Editor's Note: This section is not stable

### 8.2.1 Radio Link Addition

This procedure is used when there is already one or more existing Radio Link(s) for this UE in the Node B.

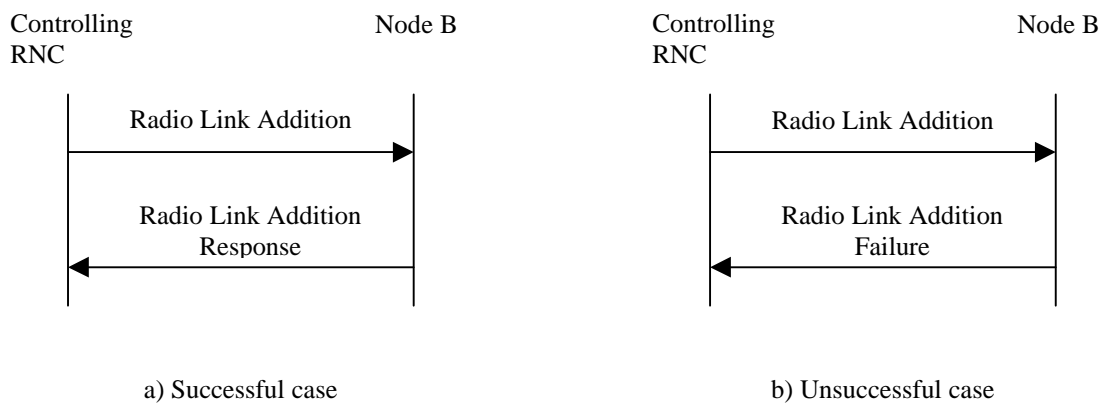

The RADIO LINK ADDITION message contains the following information (the identification of the UE is FFS):

- DL Radio Resource (DL channelisation codes) per RL
- Power control information
- the parameter “OFF” (frame offset information)
- Frequency
- RL identifier #n+1
- Target cell identifier #
- Soft combining indication (may, must, or must not be combined with already existing radio links)
- RL identifier #n+2
- Target cell identifier #
- Soft combining indication (may, must, or must not be combined with already existing radio links)
- ...

Other parameters are already known in the Node B, therefore there is no need to send them.

The RADIO LINK ADDITION RESPONSE message contains

- Transport layer addressing information (AAL2 address, AAL2 binding ID) per RL

If the transport layer addressing information is not needed in case Node B decides to use an existing AAL2 connection, then the AAL2 address is not needed and the AAL2 binding ID of the already existing AAL2 connection is sent. If the Controlling RNC receives the AAL2 binding ID of an already existing AAL2 connection, the Controlling

RNC does not execute the setting of the AAL2 connection.

## 8.2.2 Radio Link Reconfiguration (Synchronized)

The Radio Link Reconfiguration (Synchronized) procedure is used to reconfigure radio links related to one UE-UTRAN connection within Node B. The procedure can be used to add, delete or reconfigure a DCH. The Radio Link Reconfiguration procedure is initiated by the Controlling RNC by sending the message RADIO LINK RECONFIGURATION PREPARE to the Node B. The message is sent using the relevant signalling connection. It includes the desired radio link parameters for the radio links to be used continuously after completion of this procedure (no change in active set). If the proposed modifications are approved by the Node B resource management algorithms, and when the Node B has successfully reserved the required resources, it responds to the Controlling RNC with the RADIO LINK RECONFIGURATION READY message. In the unsuccessful case a NBAP message RADIO LINK RECONFIGURATION FAILURE is returned, indicating among other things the reason for failure. The Controlling RNC informs the UE about the changes in the RL with the relevant RRC message(s) after sending the RADIO LINK RECONFIGURATION COMMIT message to the Node Bs. If necessary (for example when the new L1/L2 configuration cannot coexist with the old one), the SRNC selects the most suitable CFN for the switching between the old and new configuration and includes it in the RRC message and in the RADIO LINK RECONFIGURATION COMMIT message. The Controlling RNC is responsible for releasing unnecessary Iub transport bearers (in case of DCH deletion).

This procedure is not used for adding or deleting radio links.

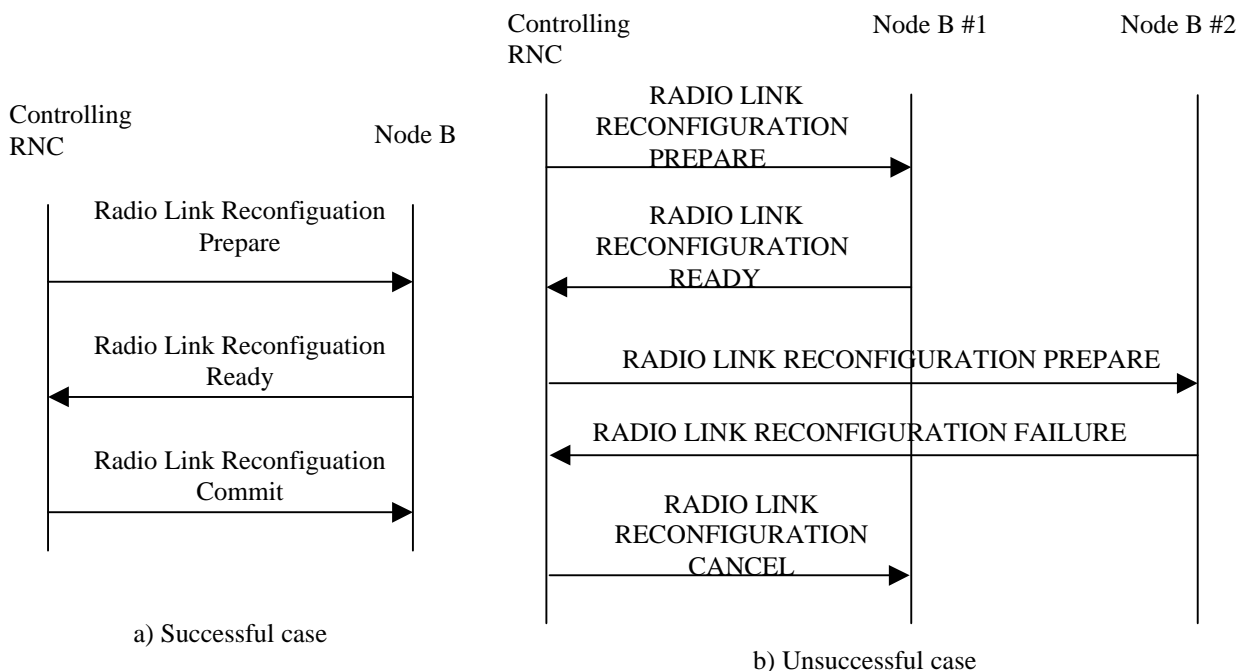

The RADIO LINK RECONFIGURATION PREPARE message contains:

- UL Radio Resources (UL Channelisation code type)
- DL Radio Resources (DL Channelisation code per RL) (if changed)
- Transport Format Combination Set

In case of DCH addition, this message also contains

- DCH Information (new DCH ID to add, Transmission Rate, Transport Format Set)
- Priority of DCH (How is it used?)

In case of DCH reconfiguration, this message also contains

- DCH Information (existing DCH ID to modify, Transmission Rate, Transport Format Set)
- Priority of modified DCH (How is it used?)

In case of DCH deletion, this message also contains

- DCH Information (DCH ID to delete)

The RADIO LINK RECONFIGURATION PREPARE message may consist of a combination of DCH addition, deletion, and reconfiguration.

The RADIO LINK RECONFIGURATION READY message contains:

- FFS

In case of DCH addition, this message also contains

- Transport layer addressing information (AAL2 address, AAL2 binding ID) for added DCH

In case of DCH reconfiguration, this message also contains

- Transport layer addressing information (AAL2 address, AAL2 binding ID) for modified DCH (if needed)

The RADIO LINK RECONFIGURATION FAILURE message contains

- CAUSE

The RADIO LINK RECONFIGURATION COMMIT message contains

- Timing information (e.g. CFN) to change old resource to new resource (FFS)



The RADIO LINK RECONFIGURATION CANCEL message contains

- Cancel information to reconfigure resources

Note: A mechanism for synchronising the switching from the old to the new configuration in the UE and in the Controlling RNC is needed and FFS.

## 8.2.3 Radio Link Reconfiguration (Unsynchronised)

The Radio Link Reconfiguration (Unsynchronised) procedure is used to reconfigure radio links related to one UE-UTRAN connection within Node B. The procedure can be used to add, delete or reconfigure a DCH.

The Unsynchronised RL Reconfiguration is used when there is no need to synchronise the time of the switching from the old to the new configuration in the node-Bs used by the UE-UTRAN connection. This is the case when new TFCs are added or old TFCs are deleted without changing the TFCI values of the TFCs that are maintained during the reconfiguration.

The Radio Link Reconfiguration procedure is initiated by the Controlling RNC by sending the message RADIO LINK RECONFIGURATION to the Node B. The message is sent using the relevant signalling connection. It includes the desired radio link parameters for the radio links to be used continuously after completion of this procedure (no change in active set).

If the proposed modifications are approved by the Node B resource management algorithms, and when the Node B has successfully reserved the required resources, it responds to the Controlling RNC with the RADIO LINK RECONFIGURATION RESPONSE message.

In the unsuccessful case a NBAP message RADIO LINK RECONFIGURATION FAILURE is returned, indicating among other things the reason for failure.

The Controlling RNC is responsible for releasing unnecessary Iub transport bearers (in case of DCH deletion).

This procedure is not used for adding or deleting radio links.

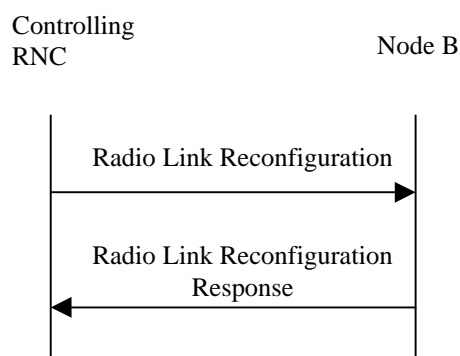

The RADIO LINK RECONFIGURATION message contains:

- Transport Format Combination Set

In case of DCH addition, this message also contains

- DCH Information (new DCH ID to add, Transmission Rate, Transport Format Set)
- Priority of DCH (How is it used?)

In case of DCH reconfiguration, this message also contains

- DCH Information (existing DCH ID to modify, Transmission Rate, Transport Format Set)
- Priority of modified DCH (How is it used?)

In case of DCH deletion, this message also contains

- DCH Information (DCH ID to delete)

The RADIO LINK RECONFIGURATION message may consist of a combination of DCH addition, deletion, and reconfiguration.

The RADIO LINK RECONFIGURATION RESPONSE message contains:

- FFS

In case of DCH addition, this message also contains

- Transport layer addressing information (AAL2 address, AAL2 binding ID) for added DCH

In case of DCH reconfiguration, this message also contains

- Transport layer addressing information (AAL2 address, AAL2 binding ID) for modified DCH (if needed)

The RADIO LINK RECONFIGURATION FAILURE message contains

- CAUSE

## 8.2.4 Radio Link Deletion

When the Controlling RNC is asked to delete a cell from the active set of a specific RRC connection, the message RADIO LINK DELETION is sent to the corresponding Node B. The message contains essentially the Radio Link identifier of the Radio Link to be deleted. Upon reception of the message, Node B should delete immediately the radio link and all related allocations within the Node B and acknowledge the deletion to the Controlling RNC with the message RADIO LINK DELETION RESPONSE.

The Controlling RNC is responsible to release the corresponding Iub transport bearers if they are not used by other radio links.

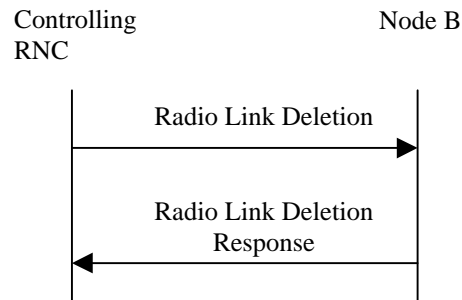

The RADIO LINK DELETION message contains (the identification of the UE is FFS):

- Radio Link Identifiers (of cells to be deleted)

The RADIO LINK DELETION RESPONSE message contains:

- FFS

## 8.2.5 DL Power Control

The purpose of this procedure is to balance the DL transmission powers of Radio Links used for the related RRC connection within the node B. DL POWER CONTROL procedure is initiated by the Controlling RNC by sending a *DL POWER CONTROL* NBAP message, which contains the desired power range for the Radio Links within the node B.



## 9 Elements for NBAP communication

### 9.1 Message functional definition and content

#### 9.1.1 Message Contents

An information element can be of the following *types*:

<b>M</b>	The information element is mandatory, i.e. always present in the message
<b>O</b>	The information element is optional, i.e. may or may not be present in the message independently on the presence or value of other information elements in the same message
<b>C</b>	The presence of the information element is conditional to the presence or to the value of another information element, as reported in the correspondent footnote

In case of an information element group, the group is preceded by a name for the info group (in bold). It is also indicated whether the group is mandatory, optional or conditional. Each group may be also repeated within one message. The presence field of the information elements inside one group defines if the information element is mandatory, optional or conditional if the group is present.

*[Editor's note] Most-right columns in the table indicate whether each parameter is used for FDD, TDD, or both. TDD parameters will be added if needed. This field is kept open for the time being.*

#### 9.1.2 Radio Link Setup

This message is sent from CRNC to Node B in order to start radio link setup for the UE in the Node B.

Information Element	Reference	Type	FDD/TDD
<b>Message Discriminator</b>		<b>M</b>	
Message Type		M	
CRNC Communication Context ID		M	
UL Scrambling Code		M	
<b>UL Channelization Code</b>		<b>M</b>	
Length of UL Channelization Code		M	
<b>DCH Information</b>		<b>M</b>	
DCH ID		M	
DCH Type		M	
UL Transport Format Set		M	
DL Transport Format Set		M	
UL Transport Format Combination Set		M	
UL TFCI used flag		(FFS)	

DL Transport Format Combination Set		M	
DL TFCI used Flag		(FFS)	
<b>RL Information</b>		<b>M</b>	
RL ID		M	
Cell ID		M	
OFF		M	
Chip Offset		M	
Diversity Control Field		C <sup>1</sup>	
DL Scrambling Code		M	
<b>DL Channelization Code</b>		<b>M</b>	
DL Channelization Code Number		M	
(initial) DL transmission power		M	
Maximum DL power		M	
Minimum DL power		M	
UL Eb/No Setpoint		FFS	
UL Eb/No Adjustment Parameters		FFS	
Maximum UL Eb/No		FFS	
Minimum UL Eb/No		FFS	
DL Reference Power		M	

### 9.1.3 Radio Link Setup Response

This message is sent from Node B to CRNC as response to the Radio Link Setup message when all RLS have been successfully setup.

Information Element	Reference	Type	FDD/TDD
<b>Message Discriminator</b>		<b>M</b>	
Message Type		M	
CRNC Communication Context ID		M	
Node B Communication Context ID		M	
Communication Control Port ID		M	
<b>RL Information Response</b>		<b>M</b>	
RL ID		M	
Diversity Indication		C <sup>2</sup>	
Reference RL ID		C <sup>3</sup>	
<b>DCH Information Response</b>		<b>C<sup>4</sup></b>	

<sup>1</sup> This Information Element is present for all the radio links except the first radio link in the Node B.

<sup>2</sup> This Information Element is present for all the radio links except the first radio link in the Node B.

<sup>3</sup> This Information Element is present when the Diversity Indication Information Element indicates combining.

<sup>4</sup> This Information Element is present when the Diversity Indication Information Element indicates non-combining.

DCH ID		M	
Binding ID		M	
Transport Layer Address		FFS	

### 9.1.4 Radio Link Setup Failure

This message is sent from Node B to CRNC as response to the Radio Link Setup message when at least one RL has not been successfully setup.

Information Element	Reference	Type	FDD/TDD
<b>Message Discriminator</b>		<b>M</b>	
Message Type		M	
CRNC Communication Context ID		M	
Node B Communication Context ID		M	
Communication Control Port ID		O	
<b>Successful RL Information Response</b>		<b>O</b>	
RL ID		M	
Diversity Indication		C <sup>5</sup>	
Reference RL ID		C <sup>6</sup>	
<b>DCH Information Response</b>		<b>C<sup>7</sup></b>	
DCH ID		M	
Binding ID		M	
Transport Layer Address		FFS	
<b>Unsuccessful RL Information Response</b>		<b>M</b>	
RL ID		M	
RL Failure Cause		M	

### 9.1.5 Radio Link Addition

This message is sent from CRNC to Node B in order to add radio link(s) for the UE in the Node B.

Information Element	Reference	Type	FDD/TDD
<b>Message Discriminator</b>		<b>M</b>	
Message Type		M	
Node B Communication Context ID		M	
Transaction ID		M	
<b>RL Information</b>		<b>M</b>	

<sup>5</sup> This Information Element is present for all the radio links except the first radio link in the Node B.

<sup>6</sup> This Information Element is present when the Diversity Indication Information Element indicates combining.

<sup>7</sup> This Information Element is present when the Diversity Indication Information Element indicates non-combining.

RL ID		M	
Cell ID		M	
OFF		M	
Chip Offset		M	
Diversity Control Field		M	
DL Scrambling Code		M	
<b>DL Channelization Code</b>		<b>M</b>	
DL Channelization Code Number		M	
(initial) DL transmission power		M	
Maximum DL power		M	
Minimum DL power		M	
UL Eb/No Setpoint		FFS	
UL Eb/No Adjustment Parameters		FFS	
Maximum UL Eb/No		FFS	
Minimum UL Eb/No		FFS	
DL Reference Power		M	

## 9.1.6 Radio Link Addition Response

This message is sent from Node B to CRNC as response to the Radio Link Addition message when all RLs have been successfully added.

Information Element	Reference	Type	FDD/TDD
<b>Message Discriminator</b>		<b>M</b>	
Message Type		M	
CRNC Communication Context ID		M	
Node B Communication Context ID		M	
Transaction ID		M	
<b>RL Information Response</b>		<b>M</b>	
RL ID		M	
Diversity Indication		M	
Reference RL ID		C <sup>8</sup>	
<b>DCH Information Response</b>		<b>C<sup>9</sup></b>	
DCH ID		M	
Binding ID		M	
Transport Layer Address		FFS	

<sup>8</sup> This Information Element is present when the Diversity Indication Information Element indicates combining.

<sup>9</sup> This Information Element is present when the Diversity Indication Information Element indicates non-combining.

### 9.1.7 Radio Link Addition Failure

This message is sent from Node B to CRNC as response to the Radio Link Addition message when at least one RL has not been successfully added.

Information Element	Reference	Type	FDD/TDD
<b>Message Discriminator</b>		<b>M</b>	
Message Type		M	
CRNC Communication Context ID		M	
Node B Communication Context ID		M	
Transaction ID		M	
<b>Successful RL Information Response</b>		<b>O</b>	
RL ID		M	
Diversity Indication		M	
Reference RL ID		C <sup>10</sup>	
<b>DCH Information Response</b>		C <sup>11</sup>	
DCH ID		M	
Binding ID		M	
Transport Layer Address		FFS	
<b>Unsuccessful RL Information Response</b>		<b>M</b>	
RL ID		M	
RL Failure Cause		M	

### 9.1.8 Radio Link Deletion

This message is sent from CRNC to Node B in order to delete radio link(s) for the UE in the Node B.

Information Element	Reference	Type	FDD/TDD
<b>Message Discriminator</b>		<b>M</b>	
Message Type		M	
Node B Communication Context ID		M	
Transaction ID		M	
<b>RL Information</b>		<b>M</b>	
RL ID		M	

### 9.1.9 Radio Link Deletion Response

This message is sent from Node B to CRNC as response to the Radio Link Deletion message.

Information Element	Reference	Type	FDD/TDD
---------------------	-----------	------	---------

<sup>10</sup> This Information Element is present when the Diversity Indication Information Element indicates combining.

<sup>11</sup> This Information Element is present when the Diversity Indication Information Element indicates non-combining.



<b>Message Discriminator</b>		<b>M</b>	
Message Type		M	
CRNC Communication Context ID		M	
Node B Communication Context ID		M	
Transaction ID		M	

### 9.1.10 RADIO LINK RECONFIGURATION PREPARE

INFORMATION ELEMENT	REFERENCE	DIRECTION	TYPE	LEN
Link Reference		DRNC-NodeB	M	
Message Identifier			M	
Length			M	
Message Compatibility Information			M	
No. of DCHs			M	
DCH ID (# 1)		For Addition	M	
TFS (for DCH ID# 1)			O	
DCH QoS			M	
DCH ID (# n)			O	
TFS (for DCH ID# n)			O	
DCH QoS			O	
TFCS (for DCHs)		For Reconfiguration	M	
UL channelization code type			M	
No. of UL channelization code			M	
UL channelization code id(s)			M	
DL channelization code type			M	
No. of DL channelization code			M	
No. of Radio Links		For Deletion	M	
Radio Link ID#1			M	
Radio Link ID#2			O	

### 9.1.11 RADIO LINK RECONFIGURATION READY

INFORMATION ELEMENT	REFERENCE	DIRECTION	TYPE	LEN
Link Reference		NodeB-DRNC	M	
Message Identifier			M	
Length			M	
Message Compatibility Information			M	
No. of DCHs			O	
DCH ID (# 1)		For Addition	O	
ATM Binding ID			O	
ATM Address			O	
DCH ID (# n)			O	
ATM Binding ID			O	
ATM Address			O	
No. of Radio Links		For Reconfiguration	M	
Radio Link ID			M	
No. of DL channelization code			M	
DL channelization code id #1			M	
DL channelization code id #m			M	
Radio Link ID		For Deletion	O	
No. of DL channelization code			O	
DL channelization code id #1			O	
DL channelization code id #m			O	

**9.1.12** RADIO LINK RECONFIGURATION COMMIT

INFORMATION ELEMENT	REFERENCE	DIRECTION	TYPE	LEN
Link Reference		DRNC-NodeB	M	
Message Identifier			M	
Length			M	
Message Compatibility Information			M	
Execution Time			M	

**9.1.13** RADIO LINK RECONFIGURATION FAILURE

INFORMATION ELEMENT	REFERENCE	DIRECTION	TYPE	LEN
Link Reference		NodeB-DRNC	M	
Message Identifier			M	
Length			M	
Message Compatibility Information			M	

**9.1.14** RADIO LINK RECONFIGURATION CANCEL

INFORMATION ELEMENT	REFERENCE	DIRECTION	TYPE	LEN
Link Reference		DRNC-NodeB	M	
Message Identifier			M	
Length			M	
Message Compatibility Information			M	

**9.1.15** POWER CONTROL

INFORMATION ELEMENT	REFERENCE	DIRECTION	TYPE	LEN
Link Reference		DRNC-NodeB	M	
Message Identifier			M	
Length			M	
Message Compatibility Information			M	
DL Power Range			M	

**9.1.16** RESET (FFS)**9.1.17** RESET ACKNOWLEDGE (FFS)**9.1.18** CONFUSION (FFS)**9.2** Information Element Functional Definition and Contents**9.2.1** Message discriminator

This field is used to discriminate between Dedicated NBAP and Common NBAP messages.

### 9.2.2 Message Type

The Message Type uniquely identifies the message being sent.

### 9.2.3 UE Context ID

Identifies the UE context in the Node B

### 9.2.4 CRNC Communication Context ID

The CRNC Communication Context ID is the identifier of the Communication Context in the CRNC.

### 9.2.5 UL Scrambling Code

The UL Scrambling Code is the scrambling code used by UE. Every UE has its specific UL Scrambling Code.

### 9.2.6 UL Channelization Code Number

The UL Channelization Code is used to preserve the orthogonality between a UE's different UL physical channels, e.g. DPDCH/DPCCH. The UL Channelization Code Number indicates the UL Channelization Code number for a specific UL physical channel an UE has.

### 9.2.7 Length of UL Channelization Code

The Length of UL Channelization Code defines the level of the channelization code in the code tree. It is equivalent to the Spreading Factor.

### 9.2.8 DCH ID

The DCH ID is the identifier of an active dedicated transport channel. It is unique for each active DCH among the active DCHs simultaneously allocated for the same UE.

### 9.2.9 DCH Type

The DCH Type is used to indicate the DCH priority level.

### 9.2.10 UL Transport Format Set

The Transport Format Set is defined as the set of Transport Formats associated to a Transport Channel, e.g. DCH. The UL Transport Format Set is applicable for UL.

### 9.2.11 DL Transport Format Set

The Transport Format Set is defined as the set of Transport Formats associated to a Transport Channel, e.g. DCH. The DL Transport Format Set is applicable for DL.

### 9.2.12 UL Transport Format Combination Set

The Transport Format Combination Set is defined as a set of Transport Format Combinations on a Coded Composite Transport Channel. It is the allowed Transport Format Combinations of the corresponding Transport Channels. The UL Transport Format Combination Set is applicable for UL Transport Channels.

### 9.2.13 TFCI used flag

Indicates whether TFCI shall be included in the DPCCH.

### 9.2.14 DL Transport Format Combination Set

The Transport Format Combination Set is defined as a set of Transport Format Combinations on a Coded Composite Transport Channel. It is the allowed Transport Format Combinations of the corresponding Transport Channels. The DL Transport Format Combination Set is applicable for DL Transport Channels.

### 9.2.15 RL ID

The RL ID is the unique identifier for one RL associated with a UE

### 9.2.16 Cell ID

The Cell ID is the identifier of a cell.

### 9.2.17 OFF

The OFF (Frame Offset) is the required offset between the dedicated channel downlink transmission frames (CFN, Connection Frame Number) and the broadcast channel frame offset (Cell Frame Number). The OFF is UE and cell specific.

### 9.2.18 Chip Offset

The Chip Offset is defined as the radio timing offset inside a radio frame. The precision is on chip level.

### 9.2.19 Diversity Control Field

The Diversity Control Field indicates if the current RL may, must or must not be combined with the already existing RLs.

### 9.2.20 DL Scrambling Code

The DL Scrambling Code is the scrambling code used for each cell/RL. It is the same for all physical channels in one cell, but different for different cells. One cell may have several DL Scrambling Codes available.

### 9.2.21 DL Channelization Code Number

The DL Channelization Code is used to preserve the orthogonality between a cell's different DL physical channels, e.g. DPCH/CCPCH. The DL Channelization Code Number indicates the DL Channelization Code

number for a specific DL physical channel a cell has.

### 9.2.22 Length of DL Channelization Code

The Length of UL Channelization Code defines the level of the channelization code in the code tree. It is equivalent to the Spreading Factor.

### 9.2.23 UL Eb/No Setpoint

The UL Eb/No Setpoint indicates the UL Eb/No target to be used by the UL inner loop power control. This is FFS and depends on the outcome of Study Item Iur/1: Signalling for UL Outer Loop Power Control and DL Power Balancing.

### 9.2.24 UL Eb/No Adjustment Parameters

The UL Eb/No Adjustment Parameters indicate the steps to be used to increase or decrease the Eb/No setpoint for the UL inner loop power control. The increase/decrease commands are carried by the FP. This is FFS and depends on the outcome of Study Item Iur/1: Signalling for UL Outer Loop Power Control and DL Power Balancing.

### 9.2.25 Maximum UL Eb/No

The Maximum UL Eb/No indicates the maximum allowed Eb/No to be used by the UL inner loop power control. This is FFS and depends on the outcome of Study Item Iub/2 (admission control in Node B).

### 9.2.26 Minimum UL Eb/No

The Minimum UL Eb/No indicates the minimum allowed Eb/No to be used by the UL inner loop power control. This is FFS and depends on the outcome of Study Item Iub/2 (admission control in Node B).

### 9.2.27 DL Reference Power

The DL Reference Power indicates the reference transmission power used by the fast UL inner loop power control to eliminate the power drifting problem. This is FFS and depends on the outcome of Study Item Iur/1: Signalling for UL Outer Loop Power Control and DL Power Balancing.

### 9.2.28 Node B Communication Context ID

The Node B Communication Context ID is the identifier of the Communication Context in the Node B, it corresponds to all the dedicated resources which are necessary for an UE using one or more dedicated channels in a given Node B.

### 9.2.29 Communication Control Port ID

A Communication Control Port corresponds to one signalling bearer between the RNC and Node B for the control of Node B Communication Contexts. Node B may have multiple Communication Control Ports (one per Traffic Termination Point). The Communication Control Port is selected at creation of the Node B Communication Context. The Communication Control Port ID is the identifier of the Communication Control Port.

### 9.2.30 Diversity Indication

The Diversity Indication indicates if the RL has been (ON) or has not been (OFF) combined with another RL.

### 9.2.31 Reference RL ID

The Reference RL ID is the identifier of the radio link that the indicated radio link has been combined with.

### 9.2.32 Binding ID

The Binding ID is the identifier of an user data stream. It is allocated at Node B and it is unique for each active transport bearer to/from the Node B.

### 9.2.33 Transport Layer Address

The Transport Layer Address indicates the Node B transport address. The format of the Transport Layer Address is FFS.

### 9.2.34 RL Failure Cause

The RL Failure Cause indicates the reason of unsuccessful radio link setup.

### 9.2.35 Transaction ID

The Transaction ID is used to associate all the messages belonging to the same pending procedure of the same NBAP procedure type (e.g. Radio Link Addition), i.e. the Request-, Response-, Confirm-type of messages have the same Transaction ID. The messages belonging to different pending procedures have different Transaction IDs.

## 9.3 Message and Information element abstract syntax (with ASN.1)

*[Editor's Note: ASN.1 shall be applied to describe the contents of each NBAP message.]*

## 9.4 Message transfer syntax

[Editor's Note: The transfer syntax to be used is FFS]

This paragraph contains the CODING of the signaling elements used.

The following convention are assumed for the sequence of transmission of bits and bytes:

Each bit position is marked as 1 to 8. Bit 1 is the least significant bit and is transmitted first.

In an element octets are identified by number, octet 1 is transmitted first, then octet 2 etc.

Length Indicator

It is desirable to have Length for messages and parameters because future version of protocol may have extension to the present message or parameter, and also variable size can be present in some parameters as well.

In case of message size exceeding 256 byte it is better to have 2 bytes for message LENGTH.

However it is enough to have 1 byte for parameter LENGTH.

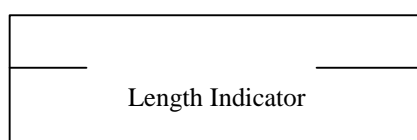

3GPP Fig. 9.2.4.1-2 Length Indicator for Parameter

Compatibility Information

Compatibility Information is used in the situation of unrecognized messages or parameter. This parameter should be placed at a certain place then it is easy to pick up this parameter in any circumstances.

Consequently, the format can be as follow:

Message Identifier / Length / Compatibility Info / parameters

Parameter Identifier / Length / Compatibility Info / Fields

Figure 3 shows the coding format of message and Figure 4 shows the coding format of parameter.

Message Identifier
Length
Compatibility Information
Parameter

Fig. 9.2.4.1-3 Message Coding Format

Parameter Identifier
Length
Compatibility Information
Field

Fig. 9.2.4.1-4 Parameter Coding Format

Fixed size data and Variable size data in Field

It may have two types of field i.e. with variable size or fixed size in data of field. It has no any problem to specify the fixed size field. Figure5 shows an example of fixed size data in field.

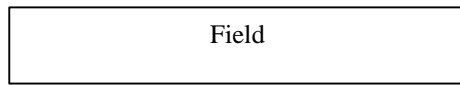

Fig. 9.2.4.1-5 Format for fixed size field

Regarding the variable size of data

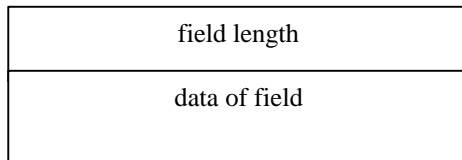

Fig. 9.2.4.1-6 Length method

The elements used and their CODING are:

Element Identifier Coding	Element name	Reference
	ATM Binding ID	
	ATM Address	
	No of DCHs	
	DCH ID	
	TFS(for DCH)	
	TFCS(for DCHs)	
	Radio Frequency	
	UL scrambling code	
	UL channelization code type	
	No. of UL channelization code	
	UL channelization code ID	
	UL Interference Level	
	DL channelization code type	
	No. of DL channelization code	
	DL channelization code id	
	Cell ID	
	Neighbor Cell Information	
	Soft Combination Indication	
	Phase Difference	



	Radio Link ID	
	No. of Radio Links	
	Execution Time	
	Slot offset	
	Frame offset	
	Initial DL Power	
	DL Power Range	
	Target UL Eb/lo	
	DCH QoS	
	LAI	
	Group number of incoming call	
	Cause	

### 9.4.1 Message Identifier

Message Identifier uniquely identifies the message being sent. It is a single octet element, mandatory in all messages.

8765 4321	
	RADIO LINK SETUP RADIO LINK SETUP RESPONSE RADIO LINK SETUP FAILURE
	RADIO LINK ADDITION RADIO LINK ADDITION RESPONSE RADIO LINK ADDITION FAILURE
	RADIO LINK DELETION RADIO LINK DELETION RESPONSE
	RADIO LINK RECONFIGURATION PREPARE RADIO LINK RECONFIGURATION READY RADIO LINK RECONFIGURATION COMMIT RADIO LINK RECONFIGURATION FAILURE RADIO LINK RECONFIGURATION CANCEL
	POWER CONTROL
	OUTER LOOP POWER CONTROL
	PAGING
	RESET (FFS)
	RESET ACKNOWLEDGE (FFS)
	RESET (FFS)

#### Message Compatibility Information

Message Compatibility Information is used in the situation of unrecognized messages.

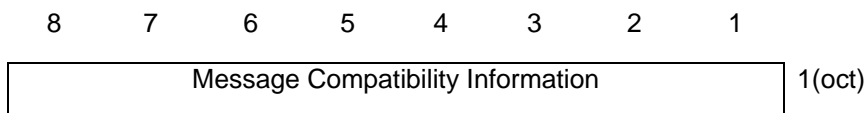
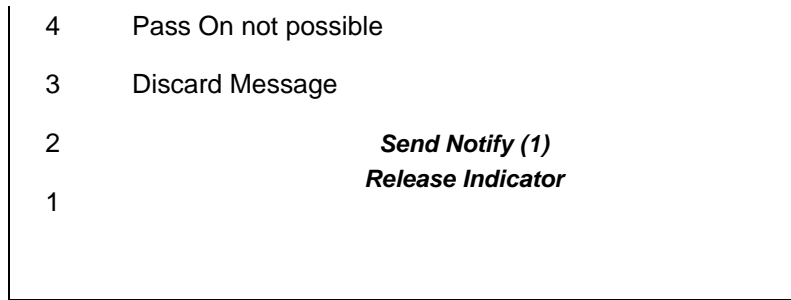

Figure: Message Compatibility Information

Table: Message Compatibility Information octet

Bit	
8	Reserved
:	



1. It should be used in CONFUSION message

### 9.4.2 Parameter Compatibility Information

Parameter Compatibility Information is used in the situation of unrecognized messages.

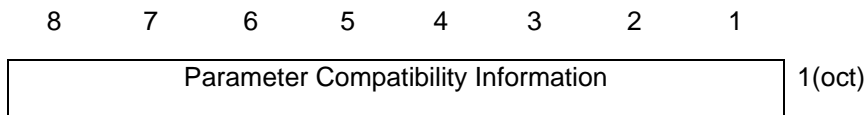
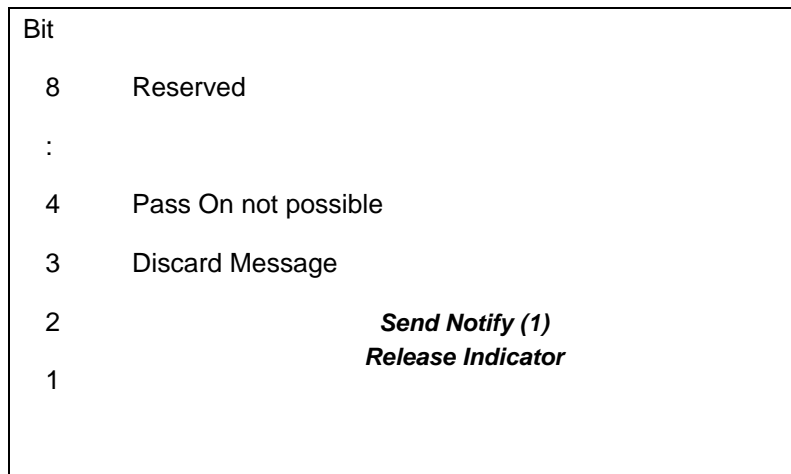

Figure: Parameter Compatibility Information

Table: Parameter Compatibility Information octet (The detail is FFS.)



1. It should be used in CONFUSION message

### 9.4.3 ATM Address

This element is included ATM address.

[Note: The following should be described the coding format. (The detail is FFS.)]

### 9.4.4 ATM Binding ID

This element is included ATM Binding ID.

[Note: The following should be described the coding format. (The detail is FFS.)]

### 9.4.5 Cell ID

This element uniquely identifies cell which a RNC and is of variable length containing.

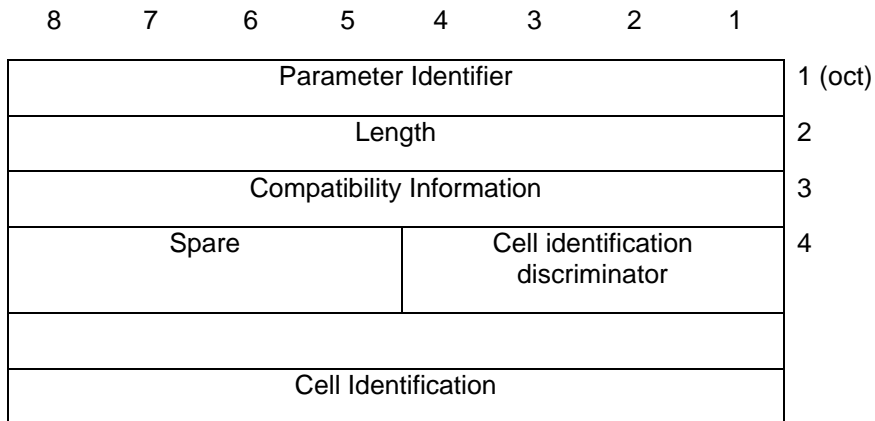

Figure: format of Cell Identifier

### 9.4.6 Neighbour Cell information

### 9.4.7 No of DCHs

### 9.4.8 DCH ID

### 9.4.9 TFS(for DCH)

### 9.4.10 TFCS(for DCHs)

### 9.4.11 Soft Combination Indication

~~9.4.12~~ Phase Difference

~~9.4.13~~ Radio Frequency

~~9.4.14~~ UL Interference level

~~9.4.15~~ UL scrambling code

~~9.4.16~~ UL channelization code type

~~9.4.17~~ No. of UL channelization codes

~~9.4.18~~ UL channelization code ID

~~9.4.19~~ DL channelization code type

~~9.4.20~~ No. of Radio Links

~~9.4.21~~ Radio Link ID

~~9.4.22~~ No. of DL channelization codes

~~9.4.23~~ DL channelization code ID

~~9.4.24~~ Execution Timer

~~9.4.25~~ Initial DL Power

### 9.4.26 DL Power Range

This Information element defines the DL transmission power range to be used for the radio links used for the related RRC connection in the node-B.

### 9.4.27 Target UL Eb/lo

### 9.4.28 Slot Offset

### 9.4.29 Frame Offset

### 9.4.30 DCH QoS

### 9.4.31 LAI

### 9.4.32 Group number of incoming call

### 9.4.33 Cause

This element is used to indicate the reason for a particular event to have occurred and is coded as shown below.

The cause value is a single octet element if the extension bit (bit 8) is set to 0. If it is set to 1 then the cause value is a 2octet field.

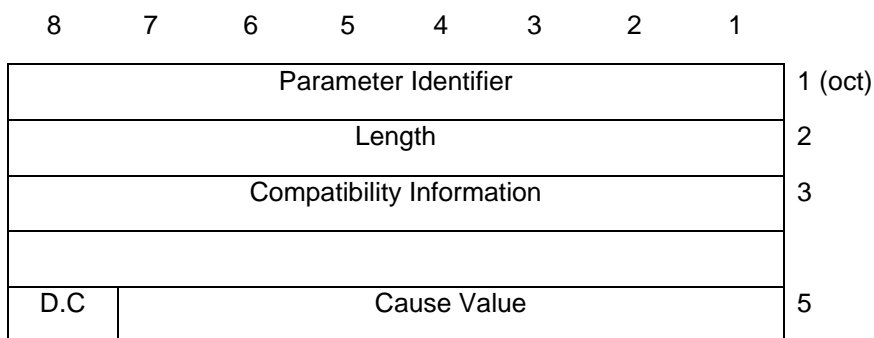

Figure: format of Cause

Cause Value:

Class: Normal event

Class: Normal event

Class: Resource unavailable

Class: Service or option not available

Class: Service or option not implemented

Class: invalid message (e.g. parameter out of range)

Class: protocol error

Class: interworking

The following table shows example of cause value.

Table: cause value

Cause Value		
Class	value	
<u>765</u>	<u>4321</u>	
		Normal termination Mobile illegal (ex. Authentication NG) O & M intervention Equipment failure Protocol error Message type non-existent or not implemented Information element/parameter non-existent or not implemented Radio link failure BS approach link failure Timer expired Ciphering algorithm not supported Resource unavailable Other values are reserved

## ~~9.5~~ Timers

---

## ~~10~~ Handling of unknown, unforeseen and erroneous protocol data

---

## ~~11~~ Annex A (normative):

## 12 History

Document history		
Edition x	<MMMM yyyy>	Publication as <old doctype> <old docnumber>
V0.0.1	March 1999	First Draft
V0.0.2	March 1999	Introduction of content from the Merged Description of I <sub>ub</sub> Interface, V0.0.2 1999-03
V0.0.3	April 1999	<p>New sections “8.1.4. Measurement Request”, “8.1.5. Measurement Termination requested by RNC”, “8.1.6. Measurement Termination requested by NodeB” and “8.1.7. Measurement Report” have been introduced. Contents in Tdoc R3-99191 have been reflected. Contents for “Measurement Termination requested by NodeB” will be contributed.</p> <p>New section “8.1.9. System Information Update Procedure” has been introduced. Contents in Tdoc R99-192 have been reflected. Several corrections and modifications have been made to “4 General”, “8.1.11 Paging”, “8.2.2 Radio Link Reconfiguration (Synchronized)”, and “8.2.4 Radio Link Deletion” reflecting the proposals in Tdoc R3-99193</p> <p>Editor’s notes were added to “8.2.6 Outer Loop Power Control”. The notes describe the raised discussion items to be solved from Tdoc R3-99176.</p> <p>“8.2.7 Down Link Code Reconfiguration Trigger” has been deleted according to the result of study item “ARC/2: DL Channelization codes are managed and allocated by CRNC to NodeB”. “9.1.16 DL CODE RECONFIGURATION REQUEST” has also been deleted.</p> <p>“Spreading Code” were renamed to “Channelization Code”</p> <p>Editor’s notes were added onto the top of 8.1.1 stating that Logical O&amp;M procedures would be included in NBAP Common Procedures</p>
V0.0.4	April 1999	New section “8.1.6 Measurement Termination initiated by NodeB” has been added according to the result from TSG-RAN WG3 meeting #2. In accordance, the title of section 8.1.5 has been changed to “8.1.5 Measurement Termination initiated by RNC”
V0.1.0	April 1999	V0.0.4 has been updated to V0.1.0 after the approval by TSG-RAN WG3
V1.0.0	April 1999	V0.1.0 has been updated to V1.0.0 after the approval by TSG-RAN WG3



V1.0.1	May 1999	<p>Chapter 3 has been detailed (definition and abbreviation were added)</p> <p>Chapter 7 has been detailed (List of messages were added)</p> <p>Section 8.1.2 has been deleted due to the change of paging termination point</p> <p>DL Power Control will be done in outband singaling (8.2.5)</p> <p>Outerloop Power Control will be done in inband signaling (8.2.6)</p> <p>Chapter 9 has been updated</p> <p>Section 9.2 has been divided into two sections, Section 9.2 and Section 9.4; Section 9.2 is for "Information Element Functional Definition and Contents. Section 9.4 is for "Message Transfer Syntax"</p> <p>New Section 9.3 will be prepared for "Message and Information element abstract syntax with ASN.1"</p> <p>Chapter 12 (Annex B) has been deleted</p>
Editor for 3GPP RAN S3.33 is:		
<p>Nobutaka Ishikawa  NTT DoCoMo  Tel.: +81 468 40 3220  Fax : +81 468 40 3840  Email : <a href="mailto:nobu@wsp.yrp.nttdocomo.co.jp">nobu@wsp.yrp.nttdocomo.co.jp</a></p>		
This document is written in Microsoft Word 98.		