

**Agenda Item:** 7

**Source:** TTC/ARIB

**Title:** TTC/ARIB lub draft specification

---

Attached is the lub specification document studied in TTC/ARIB joint meeting in Japan.

Note: Revision marks indicate the difference between the ETSI specification document and TTC/ARIB's. But ANNEX only exists in the document of TTC/ARIB.

V1.0.0 1999.1.29

## **Description of I<sub>ub</sub> Interface**

Telecommunication Technology Committee(TTC)  
Association of Radio Industries and Businesses(ARIB)

This document is agreed by  
TTC/IMT-2000 SWG-6-5-1 ARIB/IMT-2000 SWG6 GSM-G Joint Meeting.

# Contents

|            |   |    |
|------------|---|----|
| 1.         | INTELLECTUAL PROPERTY RIGHTS .....  | 6  |
| 2.         | FOREWORD.....   | 6  |
| 3.         | SCOPE.....  | 6  |
| 4.         | REFERENCES.....   | 6  |
| 5.         | DEFINITIONS, ABBREVIATIONS AND NOTATION .....   | 7  |
| 5.1        | DEFINITIONS .....   | 7  |
| 5.2        | ABBREVIATIONS .....   | 7  |
| 5.3        | NOTATION.....   | 7  |
| 6.         | GENERAL ASPECTS.....  | 7  |
| 6.1        | UTRAN ARCHITECTURE .....  | 7  |
| 6.2        | I <sub>UB</sub> -INTERFACE GENERAL PRINCIPLES AND SPECIFICATION OBJECTIVES.....           | 7  |
| 6.3        | I <sub>UB</sub> -INTERFACE CAPABILITIES.....  | 8  |
| 6.4        | I <sub>UB</sub> -INTERFACE CHARACTERISTICS.....   | 8  |
| 7.         | I <sub>UB</sub> -INTERFACE PROTOCOL FUNCTIONS .....                                       | 9  |
| 7.1        | INTERFACE FUNCTIONS .....   | 9  |
| 8.         | I <sub>UB</sub> -INTERFACE PROTOCOL STRUCTURE .....                                       | 9  |
| 9.         | I <sub>UB</sub> -INTERFACE PROTOCOL LAYER SPECIFICATION FOR RADIO NETWORK CONTROL PLANE10 |    |
| 9.1        | INTRODUCTION.....   | 10 |
| 9.2        | RADIO NETWORK LAYER .....   | 10 |
| 9.2.1      | General.....  | 10 |
| 9.2.2      | NBAP Procedures.....  | 11 |
| 9.2.2.1    | Radio Link Setup .....  | 11 |
| 9.2.2.2    | Radio Link Addition .....   | 12 |
| 9.2.2.3    | Radio Link Reconfiguration .....  | 12 |
| 9.2.2.4    | Radio Link Deletion.....  | 14 |
| 9.2.2.5    | DL Power Control.....   | 14 |
| 9.2.2.6    | Outer Loop Power Control.....   | 15 |
| 9.2.2.7    | Down Link Code Reconfiguration Trigger.....   | 15 |
| 9.2.3      | NBAP Messages.....  | 16 |
| 9.2.3.1    | Message Contents.....   | 16 |
| 9.2.3.1.1  | RADIO LINK SETUP.....   | 17 |
| 9.2.3.1.2  | RADIO LINK SETUP RESPONSE .....   | 17 |
| 9.2.3.1.3  | RADIO LINK SETUP FAILURE.....   | 18 |
| 9.2.3.1.4  | RADIO LINK ADDITION.....  | 18 |
| 9.2.3.1.5  | RADIO LINK ADDITION RESPONSE .....  | 18 |
| 9.2.3.1.6  | RADIO LINK ADDITION FAILURE.....  | 19 |
| 9.2.3.1.7  | RADIO LINK DELETION.....  | 19 |
| 9.2.3.1.8  | RADIO LINK DELETION RESPONSE .....  | 19 |
| 9.2.3.1.9  | RADIO LINK RECONFIGURATION PREPARE .....  | 19 |
| 9.2.3.1.10 | RADIO LINK RECONFIGURATION READY .....  | 20 |
| 9.2.3.1.11 | RADIO LINK RECONFIGURATION COMMIT .....   | 20 |
| 9.2.3.1.12 | RADIO LINK RECONFIGURATION FAILURE .....  | 20 |
| 9.2.3.1.13 | RADIO LINK RECONFIGURATION CANCEL .....   | 20 |
| 9.2.3.1.14 | POWER CONTROL.....  | 20 |
| 9.2.3.1.15 | OUTER LOOP POWER CONTROL .....  | 21 |
| 9.2.3.1.16 | DL CODE RECONFIGURATION REQUEST .....   | 21 |
| 9.2.3.1.17 | PAGING.....   | 21 |
| 9.2.3.1.18 | RESET (FFS).....  | 21 |
| 9.2.3.1.19 | RESET ACKNOWLEDGE (FFS) .....   | 21 |
| 9.2.3.1.20 | CONFUSION (FFS).....  | 21 |
| 9.2.4      | Signaling Element Coding.....   | 22 |
| 9.3        | TRANSPORT LAYER.....  | 27 |

|            |  |           |
|------------|--|-----------|
| 9.3.1      | General .....  | 27        |
| 9.3.2      | Signalling Bearer.....   | 27        |
| <b>10.</b> | <b>I<sub>UB</sub>-INTERFACE PROTOCOL LAYER SPECIFICATION FOR TRANSPORT NETWORK CONTROL PLANE</b> | <b>28</b> |
| 10.1       | INTRODUCTION .....   | 28        |
| 10.2       | TRANSPORT LAYER .....  | 28        |
| 10.2.1     | General .....  | 28        |
| 10.2.2     | ALCAP .....  | 28        |
| 10.2.3     | Signalling Bearer.....   | 28        |
| <b>11.</b> | <b>I<sub>UB</sub> -INTERFACE PROTOCOL LAYER SPECIFICATION FOR USER PLANE .....</b>               | <b>28</b> |
| 11.1       | INTRODUCTION .....   | 28        |
| 11.2       | RADIO NETWORK LAYER.....   | 29        |
| 11.2.1     | General .....  | 29        |
| 11.2.2     | Dedicated Channel Frame Protocol.....  | 29        |
| 11.2.2.1   | Dedicated Channel Procedures .....   | 30        |
| 11.2.2.1.1 | General .....  | 30        |
| 11.2.2.1.2 | Downlink Transfer .....  | 30        |
| 11.2.2.1.3 | Uplink Transfer .....  | 30        |
| 11.2.2.2   | Iur / Iub DCH Data Stream Synchronisation .....  | 31        |
| 11.2.3     | FACH Frame Protocol .....  | 31        |
| 11.2.4     | RACH Frame Protocol .....  | 31        |
| 11.3       | TRANSPORT LAYER .....  | 31        |
| <b>12.</b> | <b>PHYSICAL LAYER .....</b>  | <b>31</b> |
| <b>13.</b> | <b>EXAMPLE SEQUENCES.....</b>  | <b>32</b> |
| <b>14.</b> | <b>HISTORY.....</b>  | <b>32</b> |
|            | <b>ANNEX IUB PARAMETERS LIST .....</b>   | <b>32</b> |

---

# 1. Intellectual Property Rights

IPRs essential or potentially essential to the present deliverable may have been declared to ETSI. The information pertaining to these essential IPRs, if any, is publicly available for **ETSI members and non-members, free of charge**. This can be found in the latest version of the ETSI Technical Report: ETR 314: "Intellectual Property Rights (IPRs); Essential or potentially Essential, IPRs notified to ETSI in respect of ETSI standards". The most recent update of ETR 314, is available on the ETSI web server or on request from the Secretariat.

Pursuant to the ETSI Interim IPR Policy, no investigation, including IPR searches, has been carried out by ETSI. No guarantee can be given as to the existence of other IPRs not referenced in the ETR 314, which are, or may be, or may become, essential to the present document.

---

# 2. Foreword

This Technical Report (TR) has been produced by the Special Mobile Group (SMG) of the European Telecommunications Standards Institute (ETSI).

This TR describes the UTRAN RNC-NodeB (Iub) interface. The contents of this TR is subject to continuing work within TC-SMG and may change following formal TC-SMG approval.

---

# 3. Scope

This document shall provide a description of the UTRAN RNC-NodeB (Iub) interface as agreed within the TTC SWG6-5-1 / ARIB SWG6 ETSI SMG2 UMTS-ARC expert group.

---

# 4. References

References may be made to:

- a) specific versions of publications (identified by date of publication, edition number, version number, etc.), in which case, subsequent revisions to the referenced document do not apply;
- b) all versions up to and including the identified version (identified by "up to and including" before the version identity);
- c) all versions subsequent to and including the identified version (identified by "onwards" following the version identity); or
- d) publications without mention of a specific version, in which case the latest version applies.

~~A non-specific reference to an ETS shall also be taken to refer to later versions published as an EN with the same number.~~

- |         |   |
|---------|---|
| [1] [1] | ZZ.01, UTRAN Architecture Description, Editor (Nortel)  |
| [1] [2] | UMTS 23.10 UMTS Access Stratum Services and Function  |
| [1] [3] | Tdoc SMG2 UMTS-L23 110/98, Vocabulary used in the UMTS L2&L3 Expert Group                     |
| [1] [4] | ZZ.12, Description of I <sub>ur</sub> Interface, Editor (Ericsson)                            |
| [1] [5] | ZZ.11, Description of I <sub>ur</sub> Interface, Editor (Nokia)                               |
| [1] [6] | YY.01, MS-UTRAN Radio Interface Protocol Architecture, Editor (Ericsson)                      |
| [1] [7] | ITU-T I.363.2 B-ISDN ATM Adaptation Layer Specification: Type 2 AAL                           |
| [1] [8] | ITU-T I.366.1 Segmentation and Reassembly Service Specific Convergence Sublayer for AAL Type2 |
| [1] [9] | ITU-T Draft new ITU-T Recommendation Q.aal2 AAL Type2 Signalling Protocol, November 1998      |

---

## 5. Definitions, Abbreviations and Notation

### 5.1 Definitions

[Editor's note: For list of definitions, see [1].]

### 5.2 Abbreviations

[Editor's note: For list of abbreviations, see [1].]

### 5.3 Notation

[Editor's note: This text has been copied from [1].]

Parts of the document apply only to one mode, FDD or TDD. Any such area will be tagged by [FDD — xxxxxxxx] and [TDD — yyyyyyyyyyy] respectively. The tag applies to the text until the closing bracket.

---

## 6. General Aspects

### 6.1 UTRAN Architecture

[Editor's note: This chapter should describe the UTRAN architecture from  $I_{ub}$  point of view. The RNS architecture with its elements RNC and NodeB is described to facilitate the description of functional split in chapter 7. In order to avoid inconsistency between documents, reference to [1], chapter 8, has been made.]

For the description of the UTRAN architecture see [1], chapter 8.

### 6.2 $I_{ub}$ -Interface General Principles and Specification Objectives

The  $I_{ub}$  interface specifications shall facilitate the following:

- Inter-connection of RNCs and NodeBs from different manufacturers;
- Separation of  $I_{ub}$  interface Radio Network functionality and Transport Network functionality to facilitate introduction of future technology.

The general principles for the specification of the  $I_{ub}$  interface are as follows:

~~— Transmission sharing between the GSM/GPRS Abis interface and the  $I_{ub}$  interface shall not be precluded.~~

- The functional division between RNC and NodeB shall have as few options as possible;
- $I_{ub}$  should be based on a logical model of NodeB;
- NodeB controls a number of cells and can be ordered to add/remove radio links in those cells;
- Neither the physical structure nor any internal protocols of the NodeB shall be visible over  $I_{ub}$  and are thus not limiting factors, e.g., when introducing future technology.
- Operation and Maintenance of NodeB hardware and software resources is not a part of the  $I_{ub}$  standardisation.  
Note: It is FFS which functions belong to this group.
- Complex functionality shall as far as possible be avoided over  $I_{ub}$ . This is important so that the  $I_{ub}$  specification is ready on time. Advanced optimisation solutions may be added in later versions of the standard.
- The  $I_{ub}$  functional split shall take into account the probability of frequent switching between different channel types.

The  $I_{ub}$  parts to be standardised by TTC/ARIBSMG2 are:

1. User data
2. Signalling for handling the user data

3. Management of logical resources of Node B  
Note: The definition of logical resources is FFS.

It should be possible to transport the O&M information via the I<sub>ub</sub> interface and, hence, the lower layer transport mechanisms should be standardised to this effect. The content of the O&M information is not standardised by TTC/ARIBSMG2 and it is up to SMG6 to decide how to handle it.

## 6.3 I<sub>ub</sub> -Interface Capabilities

The I<sub>ub</sub> interface connects a RNC and a Node B.

The information transferred over the I<sub>ub</sub> reference point can be categorised as follows:

1. Radio application related signalling

The I<sub>ub</sub> interface allows the RNC and the Node B to negotiate about radio resources, for example to add and delete cells controlled by the Node B to support communication of the dedicated connection between UE and SRNC. Information used to control the broadcast and paging channels, and information to be transported on the broadcast and paging channels, belong to this category also.

2. I<sub>ub</sub>/I<sub>ur</sub> DCH data stream

The I<sub>ub</sub> interface provides means for transport of uplink and downlink DCH I<sub>ub</sub> frames between RNC and Node B. The DCH I<sub>ub</sub> frame header includes uplink quality estimates and synchronisation information. The DCH I<sub>ub</sub> frame body comprises of data to be transferred over the radio interface. The DCH I<sub>ub</sub> frames can be carried on pre-defined transmission links or switched connections. One I<sub>ub</sub>/I<sub>ur</sub> DCH data stream is carried on one transport bearer.

3. I<sub>ub</sub> RACH data stream

The I<sub>ub</sub> interface provides means for transport of uplink RACH transport frames between RNC and Node B. The RACH transport frame header includes synchronisation information. The RACH transport frame body includes the data received over radio interface. The transport frames can be carried on pre-defined transmission links or switched connections. One I<sub>ub</sub> RACH data stream is carried on one transport bearer. For each RACH in a cell, a I<sub>ub</sub> RACH data stream must be established over the I<sub>ub</sub> interface.

4. I<sub>ub</sub> FACH data stream

The I<sub>ub</sub> interface provides means for transport of downlink FACH transport frames between RNC and Node B. The FACH transport frame header includes synchronisation information. The FACH transport frame body includes the data to be sent over radio interface. The transport frames can be carried on pre-defined transmission links or switched connections. One I<sub>ub</sub> FACH data stream is carried on one transport bearer. For each FACH in a cell, a I<sub>ub</sub> FACH data stream must be established over the I<sub>ub</sub> interface.

- ~~5. I<sub>ub</sub> DSCH data stream~~

~~The I<sub>ub</sub> interface provides the means for transport of downlink shared channel, DSCH, data frames between RNC and Node B. The DSCH I<sub>ub</sub> frame body comprises of data to be transferred over the radio interface. The DSCH I<sub>ub</sub> frames can be carried on pre-defined transmission links or switched connections. One I<sub>ub</sub> DSCH data stream is carried on one transport bearer.~~

## 6.4 I<sub>ub</sub> -Interface Characteristics

[Editor's note: This chapter should shortly describe the I<sub>ub</sub> -Interface Characteristics.]



---

## 7. I<sub>ub</sub> -Interface Protocol Functions

[Editor's note: This chapter should describe the functions of the Iub interface. For information about the Iub interface functional division, see [1].]

### 7.1 Interface Functions

The list of functions on the Iub interface is the following:

1. Management of Iub Transport Resources
2. Logical OA&M of Node B
  - Iub Signalling Bearer Management
  - Cell Configuration Management
  - Interference Measurements
  - Notification of Available Logical Resources
  - Common Channels Management
  - Radio Resource Management
3. Physical OA&M Transport
4. Traffic Management of Common Channels
  - Admission Control
  - Power Management
  - Data Transfer
5. Traffic Management of Dedicated Channels
  - Channel Allocation / De-allocation
  - Power Management
  - Measurement Reporting
  - Dedicated Transport Channel Management
  - Data Transfer
- ~~6. Traffic Management of Downlink Shared Channels (FFS)~~
  - ~~• Channel Allocation / Deallocation~~
  - ~~• Power Management~~
  - ~~• Transport Channel Management~~
  - ~~• Data Transfer~~
- ~~6-7.~~ Timing and Synchronisation Management

---

## 8. I<sub>ub</sub> -Interface Protocol Structure

[Editor's note: This chapter should provide an introduction to the structure of the Iub interface protocols.]

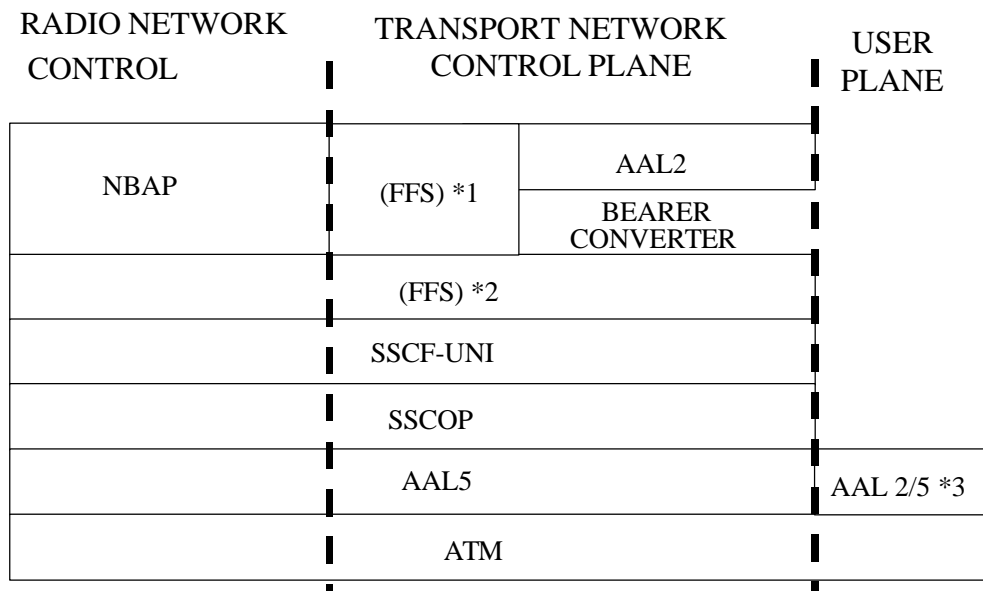

[Note \*1]: It is FFS which signalling protocol sets up AAL5 connection.

[Note \*2]: It is FFS how to distinguish NBAP from signalling protocol.

[Note \*3]: It is FFS whether AAL5 is applied to User-plane.

**Figure 1: Iub Interface Protocol Structure.**

**Note: The possibility to share AAL2 needs further clarification; the FAUSCH FP is FFS.**

The Iub interface protocol architecture consists of two functional layers:

1. Radio Network Layer, defines procedures related to the operation of Node B. The radio network layer consists of a radio network control plane and a radio network user plane.
2. Transport Layer, defines procedures for establishing physical connections between Node B and the RNC.

## 9. I<sub>ub</sub> -Interface Protocol Layer Specification for Radio Network Control Plane

### 9.1 Introduction

[Editor's note: This chapter should give an introduction to the protocol layer specification for Radio Network Control Plane.]

### 9.2 Radio Network Layer

#### 9.2.1 General

[Editor's note: This chapter should describe requirements on protocol capabilities, principles, etc..]

Node B Application protocol, NBAP, includes common procedures and traffic handling procedures. It covers procedures for paging distribution, broadcast system information, request / complete / release of dedicated resources and management of logical resources.

## 9.2.2 NBAP Procedures

NBAP procedures are divided into common procedures and dedicated procedures.

- NBAP common procedures are procedures that request initiation of a UE context for a specific UE in Node B or are not related to a specific UE.
- NBAP dedicated procedures are procedures that are related to a specific UE context in Node B. This UE context is identified by a UE context identity.

The two types of procedures may be carried on separate signalling links.

### 9.2.2.1 NBAP Common Procedures

#### 9.2.2.1.7 Radio Link Setup Request

This NBAP common procedure is used when there is no Radio Link for this UE in the Node B.

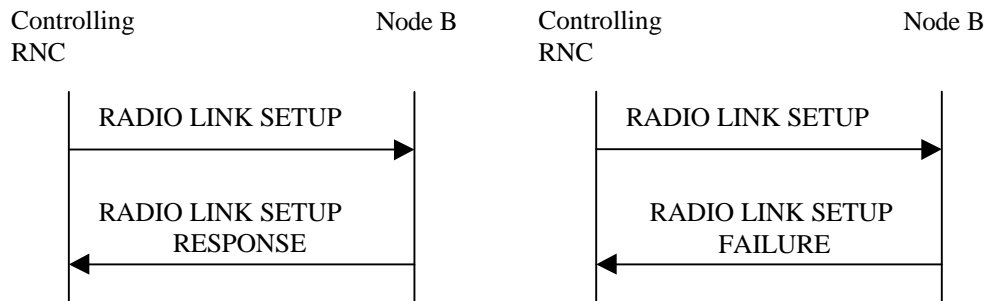

Fig1. In the Case successful

Fig2. In the Case unsuccessful

The RADIO LINK SETUP REQUEST message contains the following information (the identification of the UE is FFS):

- UL Radio Resource (UL Scrambling Code, UL Channelisation Spreading Code)
- DL Radio Resource (DL Channelisation Spreading Codes per Radio Link, DL Scrambling Code is FFS)
- DCH Information (DCH Identifier, Transmission Rate, Transport Format Set) (for each DCH in the UE)
- Transport Format Combination Set
- Power control information
- Frequency
- RL identifier #1
- Target cell identifier #
- RL identifier #2
- Target cell identifier #
- Soft combining indication (may, must, or must not be combined with already existing radio links)
- .....
- RL identifier #n
- Target cell identifier #
- Soft combining indication (may, must, or must not be combined with already existing radio links)

The RADIO LINK SETUP COMPLETE RESPONSE message contains

- Transport layer addressing information (AAL2 address/ATM Address) per RL

## 9.2.2.1 NBAP Dedicated Procedures

### 9.2.2.2.4 Radio Link Addition

This procedure is used when there is already one or more existing Radio Link(s) for this UE in the Node B.

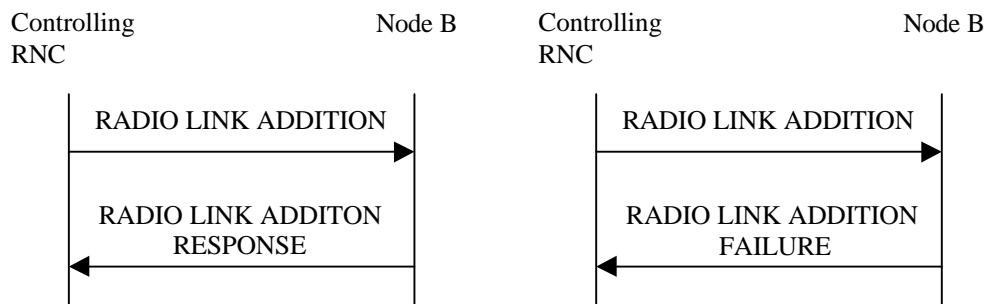

Fig1. In the Case successful

Fig2. In the Case unsuccessful

The RLRADIO LINK ADDITION message contains the following information (the identification of the UE is FFS):

- DL Radio Resource (DL channelisations/spreading codes) per RL
- Power control information
- the parameter "OFF" (frame offset information)
- Frequency
- RL identifier #n+1
- Target cell identifier #
- Soft combining indication (may, must, or must not be combined with already existing radio links)
- RL identifier #n+2
- Target cell identifier #
- Soft combining indication (may, must, or must not be combined with already existing radio links)

Other parameters are already known in the Node B, therefore there is no need to send them. In case of inter-frequency hard handover, the "soft combining indicator" of the RL identifier #n+1 should be "must not be combined".

The RLRADIO LINK ADDITION COMPLETE RESPONSE message contains

- Transport layer addressing information (AAL2 address/ATM Address, AAL2 binding/ATM Binding ID) per RL

If the transport layer addressing information is not needed in case Node B decides to use an existing AAL2 connection, then the AAL2 address/ATM Address is not needed and the AAL2 binding/ATM Binding ID of the already existing AAL2 connection is sent. If the Controlling RNC receives the AAL2 binding/ATM Binding ID of an already existing AAL2 connection, the Controlling RNC does not execute the setting of the AAL2 connection.

### 9.2.2.3.2 Radio Link Reconfiguration

The RL Reconfiguration procedure is used to reconfigure radio links related to one UE-UTRAN connection within Node B. The procedure can be used to add, delete or reconfigure a DCH. The RLRADIO LINK Reconfiguration procedure is initiated by the Controlling RNC by sending the message RLRADIO LINK RECONFIGURATION REQUEST/PREPARE to the Node B. The message is sent using the relevant signalling connection. It includes the desired radio link parameters for the radio links to be used continuously after completion of this procedure (no change in active set). If the proposed modifications are approved by the Node B resource management algorithms, and when the Node B has successfully reserved the required resources, it responds to the Controlling RNC with the RLRADIO LINK RECONFIGURATION READY PROCEEDING message. In the unsuccessful case a NBAP message RLRADIO LINK RECONFIGURATION FAILURE is returned, indicating among other things the reason for failure. The Controlling RNC informs the UE about the changes in the RL with the relevant RRC message(s) after sending the RLRADIO LINK RECONFIGURATION COMMIT COMMAND message to the Node Bs. If necessary (for example when the new L1/L2 configuration cannot coexist with the old one), the SRNC selects the most suitable CFN for the switching between the

old and new configuration and includes it in the RRC message and in the ~~RLRADIO LINK RECONFIGURATION COMMIT COMMAND~~ message. The Controlling RNC is responsible for releasing unnecessary lub transport bearers (in case of DCH deletion). This procedure is not used for adding or deleting radio links.

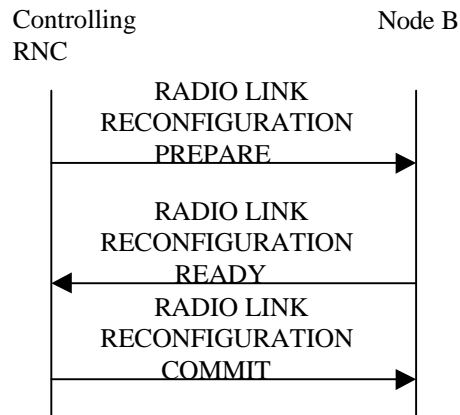

Fig1. In the Case successful

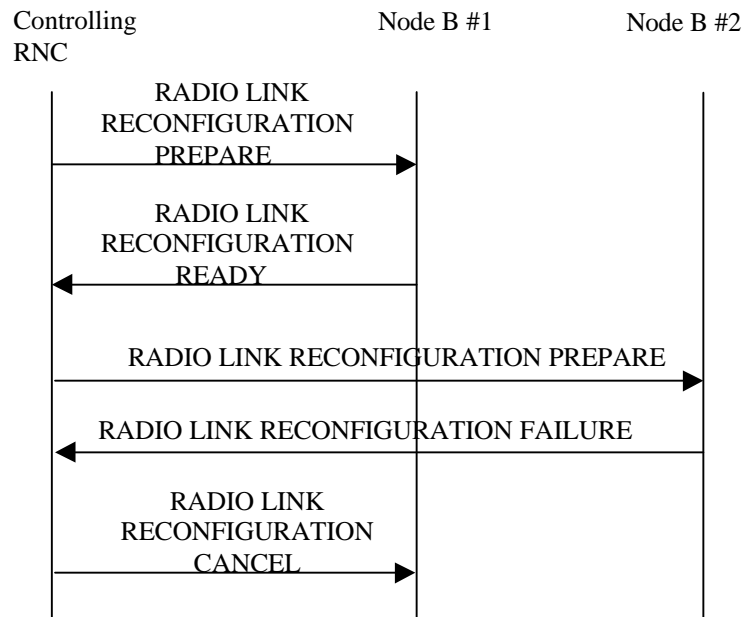

Fig2. In the Case unsuccessful

The ~~RLRADIO LINK RECONFIGURATION PREPARE REQUEST~~ message contains:

- UL Radio Resources (UL Channelisation Spreading code type)
- DL Radio Resources (DL Channelisation Spreading code per RL) (if changed)
- Transport Format Combination Set

In case of DCH addition, this message also contains

- DCH Information (new DCH ID to add, Transmission Rate, Transport Format Combination Set)
- Priority of DCH (How is it used?)

In case of DCH reconfiguration, this message also contains

- DCH Information (existing DCH ID to modify, Transmission Rate, Transport Format Combination Set)
- Priority of modified DCH (How is it used?)

In case of DCH deletion, this message also contains

- DCH Information (DCH ID to delete)

The ~~RECONFIGURATION PREPARE REQUEST~~ message may consist of a combination of DCH addition, deletion, and reconfiguration.

The ~~RLRADIO LINK RECONFIGURATION READY PROCEEDING~~ message contains:

- FFS

In case of DCH addition, this message also contains

- Transport layer addressing information (~~AAL2 address~~ATM Address, ~~AAL2 binding~~ATM Binding ID) for added DCH

In case of DCH reconfiguration, this message also contains

- Transport layer addressing information (~~AAL2 address~~ATM Address, ~~AAL2 binding~~ATM Binding ID) for modified DCH (if needed)

The ~~RLRADIO LINK RECONFIGURATION FAILURE~~ message contains

- CAUSE

The ~~RLRADIO LINK RECONFIGURATION COMMIT COMMAND~~ message contains

- Timing information to change old resource to new resource (FFS)

The RADIO LINK RECONFIGURATION CANCEL message contains

- Cancel information to reconfigure resources

Note: A mechanism for synchronising the switching from the old to the new configuration in the UE and in the Controlling RNC is needed and FFS.

### 9.2.2.42.3 Radio Link Deletion

When the Controlling RNC is asked by Node B to delete a cell from the active set of a specific RRC connection, the message ~~RLRADIO LINK DELETION REQUEST~~ is sent to the corresponding Node B. The message contains essentially the RL identifier of the RL to be deleted. Upon reception of the message, Node B should delete immediately the radio link and all related allocations within the Node B and acknowledge the deletion to the Controlling RNC with the message ~~RLRADIO LINK DELETION RESPONSE CONFIRM~~.

The Controlling RNC is responsible to release the corresponding lub transport bearers if they are not used by other radio links.

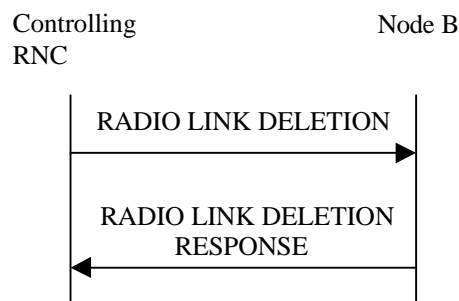

The Radio Link ~~DELETION REQUEST~~ message contains (the identification of the UE is FFS):

- Radio Link Identifiers (of cells to be deleted)

The Radio Link ~~DELETION RESPONSE CONFIRM~~ message contains:

- FFS

### 9.2.2.5 DL Power Control

The purpose of this procedure is to balance the DL transmission powers of Radio Links used for the related RRC connection within the node B. DL POWER CONTROL procedure is initiated by the Controlling RNC by sending a DL POWER CONTROL NBAP message, which contains the desired power range for the Radio Links within the node B.



### 9.2.2.6 Outer Loop Power Control

This procedure is used to provide the Node B with a new quality target value ( $E_b/I_0$ ) for the UL quality.



### 9.2.2.7 Down Link Code Reconfiguration Trigger

Down Link Code reconfiguration trigger procedure is initiated by the DRNC, when it detects unwanted fragmentation in the DL spreading code pool(s). DRNC sends DL CODE RECONFIGURATION REQUEST to the SRNC via the appropriate dedicated connection. The message includes the radio link ID(s) and proposal for the new DL spreading codes for them.

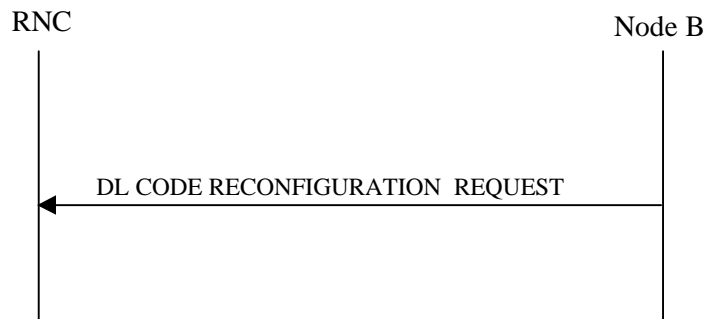

### 9.2.2.9 Common Channels Management

This procedure provides the capability to activate common channel resources such as [cell broadcast channels and] random access channels. The ability to control, for example, paging retransmission should also be provided. Information on common channel performance (eg overload) should be provided by node B to the RNC.

### 9.2.2.8 Radio Resource Management

This procedure controls the physical radio system, eg transmitter tuning and output power control functions. Procedures [will], for example, also provide for the RNC to be informed of the automatic reconfiguration of node B in the case of partial failures and the availability of redundant radio equipment.

### 9.2.2.9 Iub Signalling Bearer Management

This procedure shall deal with the management of the Iub link. This will address not only initial link establishment, but also the ongoing monitoring of link health, link recovery, load sharing and distribution.

### 9.2.2.10 Interference Measurements

[To be provided]

### 9.2.2.11 Cell Configuration Management

This procedure provides the means for the RNC to configure some of the parameters of the node B and also the means for the node B to transfer the values of these and other parameters to the RNC. Examples are: RF parameters, system information parameters and, channel configuration data.

### 9.2.2.12 Notification of Available Logical Resources

When the resources of node B which are available to the RNC change (eg due to failures within Node B or due to interactions with OMC-B), this procedure provides the means to inform the RNC of this change and/or to warn the RNC of the impending change.

## 9.2.3 NBAP Protocol Messages

[Editor's note: This chapter should describe protocol messages and information elements]

This chapter defines the structure of the messages required for the NBAP protocols.

For each message there is, a table listing the signaling elements in their order of appearance in the transmitted message.

All the NBAP messages are listed in the following table :

[Note : All of these message name are tentative, these can be changed after complete discussion]

| <u>Message name</u>                       | <u>Reference</u>  |
|---|-------------------|
| <u>RADIO LINK SETUP</u>                   | <u>9.2.3.1.1</u>  |
| <u>RADIO LINK SETUP RESPONSE</u>          | <u>9.2.3.1.2</u>  |
| <u>RADIO LINK SETUP FAILURE</u>           | <u>9.2.3.1.3</u>  |
| <u>RADIO LINK ADDITION</u>                | <u>9.2.3.1.4</u>  |
| <u>RADIO LINK ADDITION RESPONSE</u>       | <u>9.2.3.1.5</u>  |
| <u>RADIO LINK ADDITION FAILURE</u>        | <u>9.2.3.1.6</u>  |
| <u>RADIO LINK DELETION</u>                | <u>9.2.3.1.7</u>  |
| <u>RADIO LINK DELETION RESPONSE</u>       | <u>9.2.3.1.8</u>  |
| <u>RADIO LINK RECONFIGURATION PREPARE</u> | <u>9.2.3.1.9</u>  |
| <u>RADIO LINK RECONFIGURATION READY</u>   | <u>9.2.3.1.10</u> |
| <u>RADIO LINK RECONFIGURATION COMMIT</u>  | <u>9.2.3.1.11</u> |
| <u>RADIO LINK RECONFIGURATION FAILURE</u> | <u>9.2.3.1.12</u> |
| <u>RADIO LINK RECONFIGURATION CANCEL</u>  | <u>9.2.3.1.13</u> |
| <u>DL CODE RECONFIGURATION REQUEST</u>    | <u>9.2.3.1.14</u> |
| <u>POWER CONTROL</u>                      | <u>9.2.3.1.15</u> |
| <u>OUTER LOOP POWER CONTROL</u>           | <u>9.2.3.1.16</u> |
| <u>PAGING</u>                             | <u>9.2.3.1.17</u> |
| <u>RESET (FFS)</u>                        | <u>9.2.3.1.18</u> |
| <u>RESET ACKNOWLEDGE (FFS)</u>            | <u>9.2.3.1.19</u> |
| <u>CONFUSION (FFS)</u>                    | <u>9.2.3.1.20</u> |

### 9.2.3.1 Message Contents

**[Note: INFORMATION ELEMENT for each message shall be described in detail with each TYPE M/O.]**



### 9.2.3.1.1 RADIO LINK SETUP

| <u>INFORMATION ELEMENT</u>        | <u>REFERENCE</u> | <u>DIRECTION</u> | <u>TYPE</u> | <u>LEN</u> |
|-----------------------------------|------------------|------------------|-------------|------------|
| Link Reference                    |                  | DRNC-NodeB       | M           |            |
| Message Identifier                |                  |                  | M           |            |
| Length                            |                  |                  | M           |            |
| Message Compatibility Information |                  |                  | M           |            |
| No. of DCHs                       |                  |                  | M           |            |
| DCH ID (# 1)                      |                  |                  | M           |            |
| TFS (for DCH ID# 1)               |                  |                  | M           |            |
| DCH ID (# n)                      |                  |                  | M           |            |
| TFS (for DCH ID# n)               |                  |                  | M           |            |
| TFCS (for DCHs)                   |                  |                  | M           |            |
| Radio Frequency                   |                  |                  | M           |            |
| UL scrambling code                |                  |                  | M           |            |
| UL spreading code type            |                  |                  | M           |            |
| No. of UL spreading code          |                  |                  | M           |            |
| UL spreading code id(s)           |                  |                  | M           |            |
| DL spreading code type            |                  |                  | M           |            |
| No. of DL spreading code          |                  |                  | M           |            |
| No. of Radio Links                |                  |                  | M           |            |
| Radio Link ID                     |                  |                  | M           |            |
| Cell ID                           |                  |                  | M           |            |
| Phase Difference                  |                  |                  | M           |            |
| Radio Link ID                     |                  |                  | O           |            |
| Cell ID                           |                  |                  | O           |            |
| Soft Combination Indication       |                  |                  | O           |            |
| Phase Difference                  |                  |                  | O           |            |
| Slot offset                       |                  |                  | M           |            |
| Frame offset                      |                  |                  | M           |            |
| Initial DL Power                  |                  |                  | M           |            |
| Target UL Eb/lo                   |                  |                  | M           |            |

### 9.2.3.1.2 RADIO LINK SETUP RESPONSE

| <u>INFORMATION ELEMENT</u>        | <u>REFERENCE</u> | <u>DIRECTION</u> | <u>TYPE</u> | <u>LEN</u> |
|-----------------------------------|------------------|------------------|-------------|------------|
| Link Reference                    |                  | NodeB-DRNC       | M           |            |
| Message Identifier                |                  |                  | M           |            |
| Length                            |                  |                  | M           |            |
| Message Compatibility Information |                  |                  | M           |            |
| No. of DCHs                       |                  |                  | M           |            |
| DCH ID (# 1)                      |                  |                  | M           |            |
| ATM Binding ID                    |                  |                  | M           |            |
| ATM Address                       |                  |                  | O           |            |
| DCH ID (# n)                      |                  |                  | M           |            |
| ATM Binding ID                    |                  |                  | M           |            |
| ATM Address                       |                  |                  | O           |            |
| UL Interference Level             |                  |                  | M           |            |
| No. of Radio Links                |                  |                  | M           |            |
| Radio Link ID                     |                  |                  | M           |            |
| Neighbor Cell Information         |                  |                  | M           |            |
| No. of DL spreading code          |                  |                  | M           |            |
| DL spreading code id #1           |                  |                  | M           |            |
| DL spreading code id #m           |                  |                  | M           |            |
| Radio Link ID                     |                  |                  | O           |            |
| Neighbor Cell Information         |                  |                  | O           |            |
| No. of DL spreading code          |                  |                  | O           |            |

|                         |  |  |   |  |
|-------------------------|--|--|---|--|
| DL spreading code id #1 |  |  | O |  |
| DL spreading code id #m |  |  | O |  |

### 9.2.3.1.3 RADIO LINK SETUP FAILURE

| <b>INFORMATION ELEMENT</b>        | <b>REFERENCE</b> | <b>DIRECTION</b> | <b>TYPE</b> | <b>LEN</b> |
|-----------------------------------|------------------|------------------|-------------|------------|
| Link Reference                    |                  | NodeB-DRNC       | M           |            |
| Message Identifier                |                  |                  | M           |            |
| Length                            |                  |                  | M           |            |
| Message Compatibility Information |                  |                  | M           |            |
| Cause                             |                  |                  | M           |            |

### 9.2.3.1.4 RADIO LINK ADDITION

| <b>INFORMATION ELEMENT</b>        | <b>REFERENCE</b> | <b>DIRECTION</b> | <b>TYPE</b> | <b>LEN</b> |
|-----------------------------------|------------------|------------------|-------------|------------|
| Link Reference                    |                  | DRNC-NodeB       | M           |            |
| Message Identifier                |                  |                  | M           |            |
| Length                            |                  |                  | M           |            |
| Message Compatibility Information |                  |                  | M           |            |
| Radio Frequency                   |                  |                  | O           |            |
| No. of Radio Links                |                  |                  | M           |            |
| Radio Link ID                     |                  |                  | M           |            |
| Cell ID                           |                  |                  | M           |            |
| Soft Combination Indication       |                  |                  | M           |            |
| Phase Difference                  |                  |                  | M           |            |
| Radio Link ID                     |                  |                  | O           |            |
| Cell ID                           |                  |                  | O           |            |
| Soft Combination Indication       |                  |                  | O           |            |
| Phase Difference                  |                  |                  | O           |            |

### 9.2.3.1.5 RADIO LINK ADDITION RESPONSE

| <b>INFORMATION ELEMENT</b>        | <b>REFERENCE</b> | <b>DIRECTION</b> | <b>TYPE</b> | <b>LEN</b> |
|-----------------------------------|------------------|------------------|-------------|------------|
| Link Reference                    |                  | NodeB-DRNC       | M           |            |
| Message Identifier                |                  |                  | M           |            |
| Length                            |                  |                  | M           |            |
| Message Compatibility Information |                  |                  | M           |            |
| No. of DCHs                       |                  |                  | M           |            |
| DCH ID (# 1)                      |                  |                  | M           |            |
| ATM Binding ID                    |                  |                  | M           |            |
| ATM Address                       |                  |                  | O           |            |
| DCH ID (# n)                      |                  |                  | M           |            |
| ATM Binding ID                    |                  |                  | M           |            |
| ATM Address                       |                  |                  | O           |            |
| UL Interference Level             |                  |                  | O           |            |
| No. of Radio Links                |                  |                  | M           |            |
| Radio Link ID                     |                  |                  | M           |            |
| Neighbor Cell Information         |                  |                  | M           |            |
| No. of DL spreading code          |                  |                  | M           |            |
| DL spreading code id #1           |                  |                  | M           |            |
| DL spreading code id #m           |                  |                  | M           |            |
| Radio Link ID                     |                  |                  | O           |            |
| Neighbor Cell Information         |                  |                  | O           |            |
| No. of DL spreading code          |                  |                  | O           |            |
| DL spreading code id #1           |                  |                  | O           |            |
| DL spreading code id #m           |                  |                  | O           |            |

### 9.2.3.1.6 RADIO LINK ADDITION FAILURE

| <u>INFORMATION ELEMENT</u>               | <u>REFERENCE</u> | <u>DIRECTION</u>  | <u>TYPE</u> | <u>LEN</u> |
|--|------------------|-------------------|-------------|------------|
| <u>Link Reference</u>                    |                  | <u>NodeB-DRNC</u> | <u>M</u>    |            |
| <u>Message Identifier</u>                |                  |                   | <u>M</u>    |            |
| <u>Length</u>                            |                  |                   | <u>M</u>    |            |
| <u>Message Compatibility Information</u> |                  |                   | <u>M</u>    |            |
| <u>Cause</u>                             |                  |                   | <u>M</u>    |            |

### 9.2.3.1.7 RADIO LINK DELETION

| <u>INFORMATION ELEMENT</u>               | <u>REFERENCE</u> | <u>DIRECTION</u>  | <u>TYPE</u> | <u>LEN</u> |
|--|------------------|-------------------|-------------|------------|
| <u>Link Reference</u>                    |                  | <u>DRNC-NodeB</u> | <u>M</u>    |            |
| <u>Message Identifier</u>                |                  |                   | <u>M</u>    |            |
| <u>Length</u>                            |                  |                   | <u>M</u>    |            |
| <u>Message Compatibility Information</u> |                  |                   | <u>M</u>    |            |
| <u>No. of Radio Links</u>                |                  |                   | <u>M</u>    |            |
| <u>Radio Link ID #1</u>                  |                  |                   | <u>M</u>    |            |
| <u>Radio Link ID #2</u>                  |                  |                   | <u>O</u>    |            |

### 9.2.3.1.8 RADIO LINK DELETION RESPONSE

| <u>INFORMATION ELEMENT</u>               | <u>REFERENCE</u> | <u>DIRECTION</u>  | <u>TYPE</u> | <u>LEN</u> |
|--|------------------|-------------------|-------------|------------|
| <u>Link Reference</u>                    |                  | <u>NodeB-DRNC</u> | <u>M</u>    |            |
| <u>Message Identifier</u>                |                  |                   | <u>M</u>    |            |
| <u>Length</u>                            |                  |                   | <u>M</u>    |            |
| <u>Message Compatibility Information</u> |                  |                   | <u>M</u>    |            |

### 9.2.3.1.9 RADIO LINK RECONFIGURATION PREPARE

| <u>INFORMATION ELEMENT</u>               | <u>REFERENCE</u> | <u>DIRECTION</u>           | <u>TYPE</u> | <u>LEN</u> |
|--|------------------|----------------------------|-------------|------------|
| <u>Link Reference</u>                    |                  | <u>DRNC-NodeB</u>          | <u>M</u>    |            |
| <u>Message Identifier</u>                |                  |                            | <u>M</u>    |            |
| <u>Length</u>                            |                  |                            | <u>M</u>    |            |
| <u>Message Compatibility Information</u> |                  |                            | <u>M</u>    |            |
| <u>No. of DCHs</u>                       |                  |                            | <u>M</u>    |            |
| <u>DCH ID (# 1)</u>                      |                  | <u>For Addition</u>        | <u>M</u>    |            |
| <u>TFS (for DCH ID# 1)</u>               |                  |                            | <u>O</u>    |            |
| <u>DCH QoS</u>                           |                  |                            | <u>M</u>    |            |
| <u>DCH ID (# n)</u>                      |                  |                            | <u>O</u>    |            |
| <u>TFS (for DCH ID# n)</u>               |                  |                            | <u>O</u>    |            |
| <u>DCH QoS</u>                           |                  |                            | <u>O</u>    |            |
| <u>TFCS (for DCHs)</u>                   |                  | <u>For Reconfiguration</u> | <u>M</u>    |            |
| <u>UL spreading code type</u>            |                  |                            | <u>M</u>    |            |
| <u>No. of UL spreading code</u>          |                  |                            | <u>M</u>    |            |
| <u>UL spreading code id(s)</u>           |                  |                            | <u>M</u>    |            |
| <u>DL spreading code type</u>            |                  |                            | <u>M</u>    |            |
| <u>No. of DL spreading code</u>          |                  |                            | <u>M</u>    |            |
| <u>No. of Radio Links</u>                |                  | <u>For Deletion</u>        | <u>M</u>    |            |
| <u>Radio Link ID#1</u>                   |                  |                            | <u>M</u>    |            |
| <u>Radio Link ID#2</u>                   |                  |                            | <u>O</u>    |            |

### 9.2.3.1.10 RADIO LINK RECONFIGURATION READY

| <u>INFORMATION ELEMENT</u>               | <u>REFERENCE</u> | <u>DIRECTION</u>           | <u>TYPE</u> | <u>LEN</u> |
|--|------------------|----------------------------|-------------|------------|
| <u>Link Reference</u>                    |                  | <u>NodeB-DRNC</u>          | <u>M</u>    |            |
| <u>Message Identifier</u>                |                  |                            | <u>M</u>    |            |
| <u>Length</u>                            |                  |                            | <u>M</u>    |            |
| <u>Message Compatibility Information</u> |                  |                            | <u>M</u>    |            |
| <u>No. of DCHs</u>                       |                  |                            | <u>O</u>    |            |
| <u>DCH ID (# 1)</u>                      |                  | <u>For Addition</u>        | <u>O</u>    |            |
| <u>ATM Binding ID</u>                    |                  |                            | <u>O</u>    |            |
| <u>ATM Address</u>                       |                  |                            | <u>O</u>    |            |
| <u>DCH ID (# n)</u>                      |                  |                            | <u>O</u>    |            |
| <u>ATM Binding ID</u>                    |                  |                            | <u>O</u>    |            |
| <u>ATM Address</u>                       |                  |                            | <u>O</u>    |            |
| <u>No. of Radio Links</u>                |                  | <u>For Reconfiguration</u> | <u>M</u>    |            |
| <u>Radio Link ID</u>                     |                  |                            | <u>M</u>    |            |
| <u>No. of DL spreading code</u>          |                  |                            | <u>M</u>    |            |
| <u>DL spreading code id #1</u>           |                  |                            | <u>M</u>    |            |
| <u>DL spreading code id #m</u>           |                  |                            | <u>M</u>    |            |
| <u>Radio Link ID</u>                     |                  | <u>For Deletion</u>        | <u>O</u>    |            |
| <u>No. of DL spreading code</u>          |                  |                            | <u>O</u>    |            |
| <u>DL spreading code id #1</u>           |                  |                            | <u>O</u>    |            |
| <u>DL spreading code id #m</u>           |                  |                            | <u>O</u>    |            |

### 9.2.3.1.11 RADIO LINK RECONFIGURATION COMMIT

| <u>INFORMATION ELEMENT</u>               | <u>REFERENCE</u> | <u>DIRECTION</u>  | <u>TYPE</u> | <u>LEN</u> |
|--|------------------|-------------------|-------------|------------|
| <u>Link Reference</u>                    |                  | <u>DRNC-NodeB</u> | <u>M</u>    |            |
| <u>Message Identifier</u>                |                  |                   | <u>M</u>    |            |
| <u>Length</u>                            |                  |                   | <u>M</u>    |            |
| <u>Message Compatibility Information</u> |                  |                   | <u>M</u>    |            |
| <u>Execution Time</u>                    |                  |                   | <u>M</u>    |            |

### 9.2.3.1.12 RADIO LINK RECONFIGURATION FAILURE

| <u>INFORMATION ELEMENT</u>               | <u>REFERENCE</u> | <u>DIRECTION</u>  | <u>TYPE</u> | <u>LEN</u> |
|--|------------------|-------------------|-------------|------------|
| <u>Link Reference</u>                    |                  | <u>NodeB-DRNC</u> | <u>M</u>    |            |
| <u>Message Identifier</u>                |                  |                   | <u>M</u>    |            |
| <u>Length</u>                            |                  |                   | <u>M</u>    |            |
| <u>Message Compatibility Information</u> |                  |                   | <u>M</u>    |            |

### 9.2.3.1.13 RADIO LINK RECONFIGURATION CANCEL

| <u>INFORMATION ELEMENT</u>               | <u>REFERENCE</u> | <u>DIRECTION</u>  | <u>TYPE</u> | <u>LEN</u> |
|--|------------------|-------------------|-------------|------------|
| <u>Link Reference</u>                    |                  | <u>DRNC-NodeB</u> | <u>M</u>    |            |
| <u>Message Identifier</u>                |                  |                   | <u>M</u>    |            |
| <u>Length</u>                            |                  |                   | <u>M</u>    |            |
| <u>Message Compatibility Information</u> |                  |                   | <u>M</u>    |            |

### 9.2.3.1.14 POWER CONTROL

| <u>INFORMATION ELEMENT</u> | <u>REFERENCE</u> | <u>DIRECTION</u>  | <u>TYPE</u> | <u>LEN</u> |
|----------------------------|------------------|-------------------|-------------|------------|
| <u>Link Reference</u>      |                  | <u>DRNC-NodeB</u> | <u>M</u>    |            |
| <u>Message Identifier</u>  |                  |                   | <u>M</u>    |            |
| <u>Length</u>              |                  |                   | <u>M</u>    |            |

|  |  |  |          |  |
|--|--|--|----------|--|
| <u>Message Compatibility Information</u> |  |  | <u>M</u> |  |
| <u>DL Power Range</u>                    |  |  | <u>M</u> |  |

#### 9.2.3.1.15 OUTER LOOP POWER CONTROL

| <u>INFORMATION ELEMENT</u>               | <u>REFERENCE</u> | <u>DIRECTION</u>  | <u>TYPE</u> | <u>LEN</u> |
|--|------------------|-------------------|-------------|------------|
| <u>Link Reference</u>                    |                  | <u>DRNC-NodeB</u> | <u>M</u>    |            |
| <u>Message Identifier</u>                |                  |                   | <u>M</u>    |            |
| <u>Length</u>                            |                  |                   | <u>M</u>    |            |
| <u>Message Compatibility Information</u> |                  |                   | <u>M</u>    |            |
| <u>Target UL Eb/lo</u>                   |                  |                   | <u>M</u>    |            |

#### 9.2.3.1.16 DL CODE RECONFIGURATION REQUEST

| <u>INFORMATION ELEMENT</u>               | <u>REFERENCE</u> | <u>DIRECTION</u>  | <u>TYPE</u> | <u>LEN</u> |
|--|------------------|-------------------|-------------|------------|
| <u>Link Reference</u>                    |                  | <u>NodeB-DRNC</u> | <u>M</u>    |            |
| <u>Message Identifier</u>                |                  |                   | <u>M</u>    |            |
| <u>Length</u>                            |                  |                   | <u>M</u>    |            |
| <u>Message Compatibility Information</u> |                  |                   | <u>M</u>    |            |

#### 9.2.3.1.17 PAGING

| <u>INFORMATION ELEMENT</u>           | <u>REFERENCE</u> | <u>DIRECTION</u>  | <u>TYPE</u> | <u>LEN</u> |
|--------------------------------------|------------------|-------------------|-------------|------------|
| <u>Link Reference</u>                |                  | <u>DRNC-NodeB</u> | <u>M</u>    |            |
| <u>Message Identifier</u>            |                  |                   | <u>M</u>    |            |
| <u>Length</u>                        |                  |                   | <u>M</u>    |            |
| <u>LAI</u>                           |                  |                   | <u>M</u>    |            |
| <u>Group number of Incoming Call</u> |                  |                   | <u>M</u>    |            |

#### 9.2.3.1.18 RESET (FFS)

#### 9.2.3.1.19 RESET ACKNOWLEDGE (FFS)

#### 9.2.3.1.20 CONFUSION (FFS)

## 9.2.4 Signaling Element Coding

This paragraph contains the CODING of the signaling elements used.

The following convention are assumed for the sequence of transmission of bits and bytes:

Each bit position is marked as 1 to 8. Bit 1 is the least significant bit and is transmitted first.

In an element octets are identified by number, octet 1 is transmitted first, then octet 2 etc.

### Length Indicator

It is desirable to have Length for messages and parameters because future version of protocol may have extension to the present message or parameter, and also variable size can be present in some parameters as well.

In case of message size exceeding 256 byte it is better to have 2 bytes for message LENGTH.

However it is enough to have 1 byte for parameter LENGTH.

### Compatibility Information

Compatibility Information is used in the situation of unrecognized messages or parameter. This parameter should be placed at a certain place then it is easy to pick up this parameter in any circumstances.

Consequently, the format can be as follow:

Message Identifier / Length / Compatibility Info / parameters

Parameter Identifier / Length / Compatibility Info / Fields

Figure 3 shows the coding format of message and Figure 4 shows the coding format of parameter.

### Fixed size data and Variable size data in Field

It may have two types of field i.e. with variable size or fixed size in data of field. It has no any problem to specify the fixed size field. Figure5 shows an example of fixed size data in field.

Regarding the variable size of data

The elements used and their CODING are:

| <u>Element Identifier Coding</u> | <u>Element name</u>                  | <u>Reference</u> |
|----------------------------------|--------------------------------------|------------------|
|                                  | <u>ATM Binding ID</u>                |                  |
|                                  | <u>ATM Address</u>                   |                  |
|                                  | <u>No of DCHs</u>                    |                  |
|                                  | <u>DCH ID</u>                        |                  |
|                                  | <u>TFS(for DCH)</u>                  |                  |
|                                  | <u>TFCS(for DCHs)</u>                |                  |
|                                  | <u>Radio Frequency</u>               |                  |
|                                  | <u>UL scrambling code</u>            |                  |
|                                  | <u>UL spreading code type</u>        |                  |
|                                  | <u>No. of UL spreading code</u>      |                  |
|                                  | <u>UL spreading code ID</u>          |                  |
|                                  | <u>UL Interference Level</u>         |                  |
|                                  | <u>DL spreading code type</u>        |                  |
|                                  | <u>No. of DL spreading code</u>      |                  |
|                                  | <u>DL spreading code id</u>          |                  |
|                                  | <u>Cell ID</u>                       |                  |
|                                  | <u>Neighbor Cell Information</u>     |                  |
|                                  | <u>Soft Combination Indication</u>   |                  |
|                                  | <u>Phase Difference</u>              |                  |
|                                  | <u>Radio Link ID</u>                 |                  |
|                                  | <u>No. of Radio Links</u>            |                  |
|                                  | <u>Execution Time</u>                |                  |
|                                  | <u>Slot offset</u>                   |                  |
|                                  | <u>Frame offset</u>                  |                  |
|                                  | <u>Initial DL Power</u>              |                  |
|                                  | <u>DL Power Range</u>                |                  |
|                                  | <u>Target UL Eb/lo</u>               |                  |
|                                  | <u>DCH QoS</u>                       |                  |
|                                  | <u>LAI</u>                           |                  |
|                                  | <u>Group number of incoming call</u> |                  |
|                                  | <u>Cause</u>                         |                  |

### Message Identifier

Message Identifier uniquely identifies the message being sent. It is a single octet element, mandatory in all messages.

|           |   |
|-----------|---|
| 8765 4321 |   |
|           | <u>RADIO LINK SETUP</u><br><u>RADIO LINK SETUP RESPONSE</u><br><u>RADIO LINK SETUP FAILURE</u>          |
|           | <u>RADIO LINK ADDITION</u><br><u>RADIO LINK ADDITION RESPONSE</u><br><u>RADIO LINK ADDITION FAILURE</u> |
|           | <u>RADIO LINK DELETION</u><br><u>RADIO LINK DELETION RESPONSE</u>                                       |

|  |                                    |
|--|------------------------------------|
|  | RADIO LINK RECONFIGURATION PREPARE |
|  | RADIO LINK RECONFIGURATION READY   |
|  | RADIO LINK RECONFIGURATION COMMIT  |
|  | RADIO LINK RECONFIGURATION FAILURE |
|  | RADIO LINK RECONFIGURATION CANCEL  |
|  | POWER CONTROL                      |
|  | OUTER LOOP POWER CONTROL           |
|  | DL CODE RECONFIGURATION REQUEST    |
|  | PAGING                             |
|  | RESET (FFS)                        |
|  | RESET ACKNOWLEDGE (FFS)            |
|  | RESET (FFS)                        |

### Message Compatibility Information

Message Compatibility Information is used in the situation of unrecognized messages.

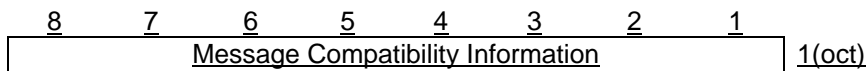

Fig.3.2.2.2 Message Compatibility Information

Table 3.2.2.2 Message Compatibility Information octet

| Bit |                      |
|-----|----------------------|
| 8   | Reserved             |
| :   |                      |
| 4   | Pass On not possible |
| 3   | Discard Message      |
| 2   | Send Notify (1)      |
| 1   | Release Indicator    |

1. It should be used in CONFUSION message

### Parameter Compatibility Information

Parameter Compatibility Information is used in the situation of unrecognized messages.

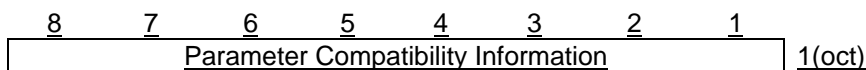

Fig.3.2.2.3 Parameter Compatibility Information

Table 3.2.2.3 Parameter Compatibility Information octet ( The detail is FFS.)

| Bit |                      |
|-----|----------------------|
| 8   | Reserved             |
| :   |                      |
| 4   | Pass On not possible |
| 3   | Discard Message      |
| 2   | Send Notify (1)      |
| 1   | Release Indicator    |

1. It should be used in CONFUSION message

### ATM Address

This element is included ATM address.

[Note: The following should be described the coding format.(The detail is FFS.)]



ATM Binding ID

This element is included ATM Binding ID.

[Note: The following should be described the coding format.(The detail is FFS.)]

Cell ID

This element uniquely identifies cell which a RNC and is of variable length containing.

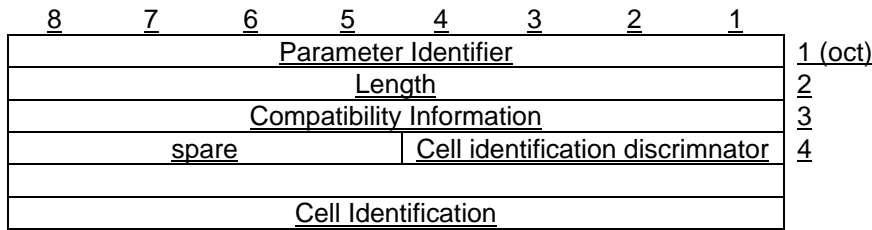

Fig.3.2.2.16 format of Cell Identifier

Neighbor Cell information

No of DCHs

DCH ID

TFS(for DCH)

TFCS(for DCHs)

Soft Combination Indication

Phase Difference

Radio Frequency

UL Interference level

UL scrambling code

UL spreading code type

No. of UL spreading codes

UL spreading code ID

DL spreading code type

No. of Radio Links

Radio Link ID

No. of DL spreading codes

DL spreading code ID

Execution Timer

Initial DL Power

DL Power Range

This Information element defines the DL transmission power range to be used for the radio links used for the related RRC connection in the node-B.

Target UL Eb/lo

Slot Offset

Frame Offset

DCH QoS

LAI

Group number of incoming call

Cause

This element is used to indicate the reason for a particular event to have occurred and is coded as shown below.

The cause value is a single octet element if the extension bit (bit 8) is set to 0. If it is set to 1 then the cause value is a 2octet field.

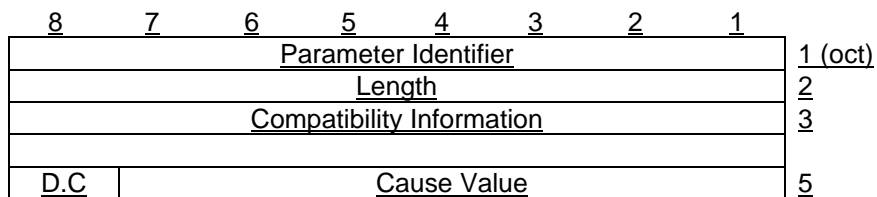

Fig.3.2.2.7 format of Cause

Cause Value:

- Class : Normal event
- Class: Normal event
- Class: Resource unavailable
- Class : Service or option not available
- Class : Service or option not implemented
- Class : invalid message (eg parameter out of range)
- Class : protocol error
- Class : interworking

The following table shows example of cause value.

Table3.2.2.7 cause value

| Cause Value |  |
|-------------|--|
| Class       | value  |
| 765         | 4321   |
|             | <ul style="list-style-type: none"> <li><u>Normal termination</u></li> <li><u>Mobile illegal (ex. Authentication NG)</u></li> <li><u>O &amp; M intervention</u></li> <li><u>Equipment failure</u></li> <li><u>Protocol error</u></li> <li><u>Message type non-existent or not implemented</u></li> <li><u>Information element/parameter non-existent or not implemented</u></li> <li><u>Radio link failure</u></li> <li><u>BS approach link failure</u></li> <li><u>Timer expired</u></li> <li><u>Ciphering algorithm not supported</u></li> <li><u>Resource unavailable</u></li> <li><u>Other values are reserved</u></li> </ul> |

## 9.3 Transport Layer

### 9.3.1 General

[Editor's note: This chapter should e.g. describe Radio Network Layer requirements on Transport Layer protocols.]

### 9.3.2 Signalling Bearer

The Signalling Bearer for the NBAP is a point-to-point protocol. There may be multiple point-to-point links between an RNC and a Node B.

Two alternatives have been identified for the signalling bearer in the Radio Network Control Plane, SAAL-UNI over ATM and TCP/IP / AAL5. The current working assumption is to use SAAL-UNI as the signalling bearer for NBAP.

---

# 10. I<sub>ub</sub>-Interface Protocol Layer Specification for Transport Network Control Plane

## 10.1 Introduction

[Editor's note: This chapter should describe general requirements and structure of the Transport Network Control Plane.]

## 10.2 Transport Layer

### 10.2.1 General

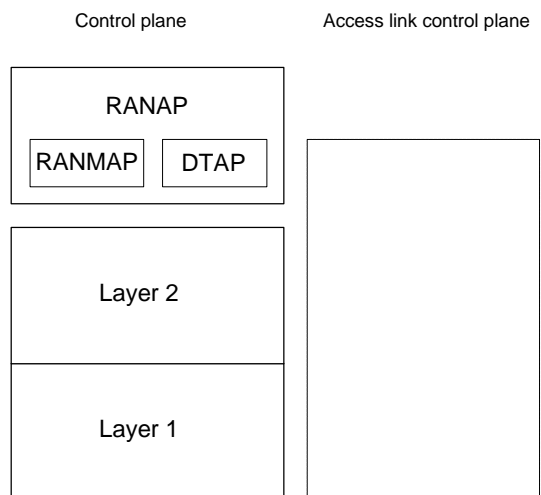

Figure 2: Transport Network Control plane protocol structure on Iub.

### 10.2.2 ALCAP

Working assumption: Q.aal2 under development by ITU SG11 [9] is selected as that standard AAL2 signalling protocol for Iub.

### 10.2.3 Signalling Bearer

Working assumption: SAAL-UNI is the standard signalling bearer for the AAL Type Signalling protocol (Q.aal2) on Iub.

---

# 11. I<sub>ub</sub> -Interface Protocol Layer Specification for User Plane

## 11.1 Introduction

[Editor's note: This chapter should describe the structure of the User Plane.]

The description of the structure of I<sub>ur</sub> and I<sub>ub</sub> data frames is included here, but not in [4]. The I<sub>ur</sub> data stream shall follow the same specification as the I<sub>ub</sub> data stream [1].

## 11.2 Radio Network Layer

### 11.2.1 General

~~[Editor's note: This chapter should describe structure of  $I_{ub}$  data streams]~~

For the user plane of the radio network layer there are four protocols:

- Dedicated Channel Frame Protocol (DCH FP) for transport of  $I_{ub}$  data streams carried on dedicated channels on the Uu-interface.
- Random Access Channel Frame Protocol (RACH FP) for transport of  $I_{ub}$  data streams carried on RACH on the Uu-interface.
- Forward Access Channel Frame Protocol (FACH FP) for transport of  $I_{ub}$  data streams carried on FACH on the Uu-interface.
- ~~Downlink Shared Channel Frame Protocol (DSCH FP) for transport of  $I_{ub}$  data streams carried on DSCH on the Uu-interface.~~

~~Note: FAUSCH frame protocol is FFS (depending on the decision of Layer 1 Expert Group).~~

### 11.2.2 Dedicated Channel Frame Protocol

The specification of  $I_{ub}$  DCH data streams is also valid for  $I_{ur}$  DCH data streams.

The parameters to be included in the  $I_{ub}$  frames to be transported between Node B and Serving RNC (i.e., they apply for  $I_{ur}$  and  $I_{ub}$  data stream) are:

1. **User data** - a block of user data.
2. **Connection ID** - used by soft combining function to identify multiple paths of the same call.
3. **Quality Indication** - used by soft combining function.
4. **Length Indicator** - used to allow different frame sizes and different user rates.
5. **CRC** - error check for the frame.
6. **Rx power** - indication of received power level in uplink only.
7. **Frame Type** - e.g. signalling or data.
8. **CFN** – the connection frame number is the indicator as to which radio frame the data should be transmitted / was received. It is also needed for synchronisation purposes in DL channel frames.
9. **Timing adjustment command** – needed for synchronisation purposes in UL channel frames.

~~[Note: This list of parameters is the starting assumption and not necessarily comprehensive.]~~

Two different message types are to be used for both the downlink and uplink DCH Transport Channel Frame protocol in the  $I_{ur}$  and  $I_{ub}$  interfaces.

- DCH data frame
- DCH control frame

The DCH control frame shall be used for inband signalling between SRNC and Node B in cases where the normal DCH data frame can not be utilised. The DCH control frame shall not carry any data targeted to or received from the air interface. Typical use for the DCH control frame would be synchronisation of the user plane and transport of DL outer loop power control commands.

## 11.2.2.1 Dedicated Channel Procedures

### 11.2.2.1.1 General

The SRNC is responsible for creating communications inside the SRNS. The SRNC provides to the Node B the complete configuration of the Transport channels to be provided by the Node B for a given communication. The parameters of a Transport channel are described in [6]. These Transport channels are multiplexed on the downlink by the Node B on radio physical channels, and de-multiplexed on the uplink from radio physical channels to Transport channels.

Every Transport channel related to one UE context that is communicated over a set of cells that are macro-diversity combined within Node B, is carried on one AAL2 connection. This means that there are as many AAL2 connections as Transport channels and User ports for that communication.

It is FFS whether unidirectional or bi-directional AAL2 connections are used.

### 11.2.2.1.2 Downlink Transfer

Every Transmission Time Period (typically one radio frame, i.e. 10ms), for each Transport channel, the SRNC provides to the Node B the following information:

- a Transport Bloc Set (user data) to be sent on the radio interface
- the Transport Format Indicator (TFI) to use

The CID of the AAL2 frame identifies the lub data stream where a Transport channel frame is transported.

| Information element                 | Description  |
|-------------------------------------|--|
| Message type                        | Downlink DCH Transport channel frame   |
| Transport Format Indicator          | The TFI identifies the format of the transport channel to be used on the radio interface |
| Transport Bloc Set                  | This contains the data to be sent on the radio interface                                 |
| Outer Loop Power Control (optional) | This may update the target outer loop power control                                      |

### 11.2.2.1.3 Uplink Transfer

Every Transmission Time Period (typically one radio frame, i.e. 10ms), for each Transport channel, the Node B sends to the SRNC the following information:

- a Transport Bloc Set (user data) received from the radio interface
- the Transport Format Indicator (TFI) associated to the Transport Bloc Set
- A Quality indicator:  
Bad / Good frame

Other Quality indications are FFS.

When the frame is incorrectly received, it is not sent on the lur interface.

| Information element        | Description   |
|----------------------------|---|
| Message type               | Uplink DCH Transport channel frame  |
| Transport Format Indicator | The TFI identifies the format of the transport channel as received from the radio interface |
| Transport Bloc Set         | This contains the data received from the radio interface                                    |
| Quality indicator          | This may update the target outer loop power control   |

### 11.2.2.2 Iur / Iub DCH Data Stream Synchronisation

To synchronise and keep the synchronisation of a DCH data stream SRNC includes a Connection Frame Number (CFN) to all DL DCH Transport channel frames. If there is no data to be transmitted to the UE via the DCH transport bearer then a special DL DCH Control frames can be sent instead of DL DCH data frames.

Upon reception of a DL DCH Transport channel frame, node B should evaluate the time difference between the optimal arrival time for the DL DCH Transport Channel frame to be transmitted in the indicated CFN and the actual measured arrival time of the DL DCH Transport channel frame.

According to the measured time difference, node B should set a proper value for the Timing adjustment command in the UL DCH transport channel frame. If there is no UL data to be transmitted to the SRNC via the DCH transport bearer then a special UL DCH Control frame can be sent.

(The initial value for the parameters is FFS)

### 11.2.3 FACH Frame Protocol

The parameters to be included in the Iub FACH frames are:

1. **CELL FN** – the cell frame number is needed for synchronisation purposes.

### 11.2.4 RACH Frame Protocol

The parameters to be included in the Iub RACH frames are:

1. **CELL FN** – the cell frame number is needed for synchronisation purposes.

### ~~11.2.5 DSCH Frame Protocol~~

## 11.3 Transport Layer

~~[Editor's note: This chapter should refer to specifications of the Transport Layer protocol(s). Limitations in usage of options of the protocol(s) should be described.]~~

Iub / Iur DCH data stream for soft handover [FDD]:

ATM and AAL2 is used as a standard transport layer for DCH data streams across the Iur and Iub interfaces. Other protocols such as Frame Relay and ATM AAL5 are FFS.

~~Iub / Iur DCH data stream for soft handover [TDD]:~~

~~FFS~~

ATM and AAL2 type 2 (I363.2 and I366.1) is used at the standard transport layer for Iub RACH and FACH data streams.

Note: This assumes that MAC scheduling is in the RNC. This decision is to be confirmed when protocol termination points are decided.

---

## 12. Physical Layer

~~[Editor's note: This chapter should refer to specifications of the Physical Layer. Limitations in usage of options of the protocol(s) should be described.]~~

Working assumption:

When using multiple low speed links in the Iub interface, the Node B shall support IMA (Inverse Multiplexing for ATM).

---

## 13. Example Sequences

[Editor's note: This chapter should contain examples of sequences including both Radio Network Signalling and Transport Signalling.]

---

## 14. History

| <b>Document history</b> |                |                |
|-------------------------|----------------|----------------|
| <b>Date</b>             | <b>Version</b> | <b>Comment</b> |
| Jan 29 1999             | 1.0.0          | First draft    |



---

## ANNEX Iub Parameters List

### Paging

| Parameter Category         | Iub Parameters             | Iub Message | Note |
|----------------------------|----------------------------|-------------|------|
|                            |                            | PAGING      |      |
| LAI                        | LAI                        | m           |      |
| Group No. of Incoming Call | Group No. of Incoming Call | m           |      |

## RRC Connection Setup

| Parameter Category                     | Sub Parameters           | Sub Message                        |  |   | Note                               |
|--|--------------------------|------------------------------------|--|---|------------------------------------|
|  |                          | IDLE to DCH                        |  |   |                                    |
|  |                          | RA<br>DIO<br>LIN<br>K<br>SET<br>UP | RA<br>DIO<br>LIN<br>K<br>SET<br>UP<br>RES<br>PO<br>NSE | RA<br>DIO<br>LIN<br>K<br>SET<br>UP<br>FAI<br>LUR<br>E |                                    |
| Transport CH Info                      | No. of DCHs              | m                                  | -  | -   |                                    |
|  | DCH ID (# 1)             | m                                  | -  | -   | DCH ID or each DCH                 |
|  | TFS (for DCH ID# 1)      | m                                  | -  | -   | Set TFS when it is required        |
|  | :                        |                                    |  |   |                                    |
|  | DCH ID (# n)             | m                                  | -  | -   |                                    |
|  | TFS (for DCH ID# n)      | m                                  | -  | -   |                                    |
|  | TFCS (for DCHs)          | m                                  | -  | -   | Set TFCS per UE                    |
| Transport Layer Addressing Information | No. of DCHs              | -                                  | m  | -   |                                    |
|  | DCH ID (# 1)             | -                                  | m  | -   |                                    |
|  | ATM Binding ID           | -                                  | m  | -   | (TTC) 1 Binding ID for 1 DCH *1    |
|  | ATM Address              | -                                  | o  | -   |                                    |
|  | :                        |                                    |  |   |                                    |
|  | DCH ID (# n)             | -                                  | m  | -   |                                    |
|  | ATM Binding ID           | -                                  | m  | -   |                                    |
|  | ATM Address              | -                                  | o  | -   |                                    |
| Radio Frequency Info                   | Radio Frequency          | m                                  | -  | -   | Set Radio Frequency per UE         |
|  | UL Interference Level    | -                                  | m  | -   |                                    |
| UL Radio Resources                     | UL scrambling code       | m                                  | -  | -   | Set UL Scrambling Code per UE      |
|  | UL spreading code type   | m                                  | -  | -   |                                    |
|  | No. of UL spreading code | m                                  | -  | -   |                                    |
|  | UL spreading code id(s)  | m                                  | -  | -   |                                    |
| DL Radio Resources                     | DL spreading code type   | m                                  | -  | -   | Same code type for all Radio Links |

|                              |                            |   |   |   |   |
|------------------------------|----------------------------|---|---|---|---|
|                              | No. of DL spreading code   | m | - | - | Same number of codes for all Radio Links    |
|                              | No. of Radio Links         | m | - | - |   |
|                              | Radio Link ID              | m | - | - |   |
|                              | Cell ID                    | m | - | - |   |
|                              | Soft Combination Indicator | - | - | - | Indicates May, Must, Must not               |
|                              | Phase Difference           | m | - | - |   |
|                              | :                          |   |   |   |   |
|                              | Radio Link ID              | o | - | - |   |
|                              | Cell ID                    | o | - | - |   |
|                              | Soft Combination Indicator | o | - | - |   |
|                              | Phase Difference           | o | - | - |   |
| DL Radio Resources           | No. of Radio Links         | - | m | - |   |
|                              | Radio Link ID              | - | m | - |   |
|                              | Neighbor Cell Information  | - | m | - | FFS*2                                       |
|                              | No. of DL spreading code   | - | m | - |   |
|                              | DL spreading code id #1    | - | m | - |   |
|                              | :                          |   |   |   |   |
|                              | DL spreading code id #m    | - | m | - |   |
|                              | :                          |   |   |   |   |
|                              | Radio Link ID              | - | o | - |   |
|                              | Neighbor Cell Information  | - | o | - | FFS   |
|                              | No. of DL spreading code   | - | o | - |   |
|                              | DL spreading code id #1    | - | o | - |   |
|                              | :                          |   |   |   |   |
|                              | DL spreading code id #m    | - | o | - |   |
| Execution Time               | Execution Time             | - | - | - |   |
| Offset Values                | Slot offset                | m | - | - |   |
|                              | Frame offset               | m | - | - |   |
| Power Control Info           | Initial DL Power           | m | - | - | For Initial DL Power Setting                |
|                              | DL Power Range             | - | - | - | For Correcting DL Power Drifting during DHO |
| Outerloop Power Control Info | Target UL Eb/lo            | m | - | - | For L1 Power Control                        |
| Cause                        | Cause                      | - | - | m |   |

m: mandatory, o: optional

\*1: In TTC assumption, in the case of intra RFTR RL addition in intra-frequency, it is always soft combined in RFTR. Also in the case of intra RFTR RL addition in inter-frequency, same lub ATM connection is used. Therefore, in case of RADIO LINK ADDITION resp.conf.(Inter RFTR), RFTR send existing binding ID to RACFd.

\*2: Contents of this information is FFS. It is related to BS addressing scheme.

**RAB Setup**

| Parameter Category                     | Iub Parameters      | Iub Message  |  |   |   |   |  |   |   |   |   | Note                            |
|--|---------------------|--|--|---|---|---|--|---|---|---|---|---------------------------------|
|  |                     | RA/FACH to DCH   |  |   | DCH to DCH  |   |  |   |   | DCH to RA/FACH  |   |                                 |
|  |                     | R<br>A<br>D<br>I<br>O<br><br>L<br>I<br>N<br>K<br>S<br>E<br>T<br>U<br>P | RA<br>DIO<br>LIN<br>K<br>S<br>E<br>T<br>U<br>P<br>R<br>E<br>S<br>P<br>O<br>N<br>S<br>E | RA<br>DIO<br>LIN<br>K<br>S<br>E<br>T<br>U<br>P<br>F<br>A<br>I<br>L<br>U<br>R<br>E | RA<br>DIO<br>LIN<br>K<br>R<br>E<br>C<br>O<br>N<br>F<br>I<br>G<br>U<br>R<br>A<br>T<br>I<br>O<br>N<br>P<br>R<br>E<br>P<br>A<br>R<br>E | RA<br>DIO<br>LIN<br>K<br>R<br>E<br>C<br>O<br>N<br>F<br>I<br>G<br>U<br>R<br>A<br>T<br>I<br>O<br>N<br>R<br>E<br>A<br>D<br>Y | RA<br>DIO<br>LIN<br>K<br>R<br>E<br>C<br>O<br>N<br>F<br>I<br>G<br>U<br>R<br>A<br>T<br>I<br>O<br>N<br>C<br>O<br>M<br>M<br>I<br>T | RA<br>DIO<br>LIN<br>K<br>R<br>E<br>C<br>O<br>N<br>F<br>I<br>G<br>U<br>R<br>A<br>T<br>I<br>O<br>N<br>F<br>A<br>I<br>L<br>U<br>R<br>E | RA<br>DIO<br>LIN<br>K<br>R<br>E<br>C<br>O<br>N<br>F<br>I<br>G<br>U<br>R<br>A<br>T<br>I<br>O<br>N<br>C<br>A<br>N<br>C<br>E<br>L<br>(F<br>F<br>S) | R<br>A<br>D<br>I<br>O<br><br>L<br>I<br>N<br>K<br>D<br>E<br>L<br>E<br>T<br>I<br>O<br>N | RA<br>DIO<br>LIN<br>K<br>D<br>E<br>L<br>E<br>T<br>I<br>O<br>N<br>R<br>E<br>S<br>P<br>O<br>N<br>S<br>E |                                 |
| Transport CH Info                      | No. of DCHs         | m  | -  | -   | m   | -   | -  | -   | -   | -   | -   |                                 |
|  | DCH ID (# 1)        | m  | -  | -   | m   | -   | -  | -   | -   | -   | -   | DCH ID or each DCH              |
|  | TFS (for DCH ID# 1) | m  | -  | -   | m   | -   | -  | -   | -   | -   | -   | Set TFS when it is required     |
|  | :                   |  |  |   |   |   |  |   |   |   |   |                                 |
|  | DCH ID (# n)        | m  | -  | -   | m   | -   | -  | -   | -   | -   | -   |                                 |
|  | TFS (for DCH ID# n) | m  | -  | -   | m   | -   | -  | -   | -   | -   | -   |                                 |
|  | TFCS (for DCHs)     | m  | -  | -   | m   | -   | -  | -   | -   | -   | -   | Set TFCS per UE                 |
| Transport Layer Addressing Information | No. of DCHs         | -  | m  | -   | -   | m   | -  | -   | -   | -   | -   |                                 |
|  | DCH ID (# 1)        | -  | m  | -   | -   | m   | -  | -   | -   | -   | -   |                                 |
|  | ATM Binding ID      | -  | m  | -   | -   | m   | -  | -   | -   | -   | -   | (TTC) 1 Binding ID for 1 DCH *1 |
|  | ATM Address         | -  | o  | -   | -   | o   | -  | -   | -   | -   | -   |                                 |

|                      |                            |   |   |   |   |   |   |   |   |   |   |  |
|----------------------|----------------------------|---|---|---|---|---|---|---|---|---|---|--|
|                      | :                          |   |   |   |   |   |   |   |   |   |   |  |
|                      | DCH ID (# n)               | - | m | - | - | m | - | - | - | - | - |  |
|                      | ATM Binding ID             | - | m | - | - | m | - | - | - | - | - |  |
|                      | ATM Address                | - | o | - | - | o | - | - | - | - | - |  |
| Radio Frequency Info | Radio Frequency            | m | - | - | - | - | - | - | - | - | - | Set Radio Frequency per UE               |
|                      | UL Interference Level      | - | m | - | - | - | - | - | - | - | - |  |
| UL Radio Resources   | UL scrambling code         | m | - | - | - | - | - | - | - | - | - | Set UL Scrambling Code per UE            |
|                      | UL spreading code type     | m | - | - | m | - | - | - | - | - | - |  |
|                      | No. of UL spreading code   | m | - | - | m | - | - | - | - | - | - |  |
|                      | UL spreading code id(s)    | m | - | - | m | - | - | - | - | - | - |  |
| DL Radio Resources   | DL spreading code type     | m | - | - | m | - | - | - | - | - | - | Same code type for all Radio Links       |
|                      | No. of DL spreading code   | m | - | - | m | - | - | - | - | - | - | Same number of codes for all Radio Links |
|                      | No. of Radio Links         | m | - | - | m | - | - | - | - | m | - |  |
|                      | Radio Link ID              | m | - | - | m | - | - | - | - | m | - |  |
|                      | Cell ID                    | m | - | - | - | - | - | - | - | - | - |  |
|                      | Soft Combination Indicator | - | - | - | - | - | - | - | - | - | - | Indicates May, Must, Must not            |
|                      | Phase Difference           | m | - | - | - | - | - | - | - | - | - |  |
|                      | :                          |   |   |   |   |   |   |   |   |   |   |  |
|                      | Radio Link ID              | o | - | - | o | - | - | - | - | o | - |  |
|                      | Cell ID                    | o | - | - | - | - | - | - | - | - | - |  |
|                      | Soft Combination Indicator | o | - | - | - | - | - | - | - | - | - |  |
|                      | Phase Difference           | o | - | - | - | - | - | - | - | - | - |  |
| DL Radio Resources   | No. of Radio Links         | - | m | - | - | m | - | - | - | - | - |  |
|                      | Radio Link ID              | - | m | - | - | m | - | - | - | - | - |  |
|                      | Neighbor Cell Information  | - | m | - | - | - | - | - | - | - | - | FFS*2                                    |
|                      | No. of DL spreading code   | - | m | - | - | m | - | - | - | - | - |  |
|                      | DL spreading code id #1    | - | m | - | - | m | - | - | - | - | - |  |
|                      | :                          |   |   |   |   |   |   |   |   |   |   |  |
|                      | DL spreading code id #m    | - | m | - | - | m | - | - | - | - | - |  |
|                      | :                          |   |   |   |   |   |   |   |   |   |   |  |
|                      | Radio Link ID              | - | o | - | - | o | - | - | - | - | - |  |
|                      | Neighbor Cell Information  | - | o | - | - | - | - | - | - | - | - | FFS                                      |
|                      | No. of DL spreading code   | - | o | - | - | o | - | - | - | - | - |  |
|                      | DL spreading code id #1    | - | o | - | - | o | - | - | - | - | - |  |

|                              |                         |   |   |   |   |   |   |   |   |   |   |   |
|------------------------------|-------------------------|---|---|---|---|---|---|---|---|---|---|---|
|                              | :                       |   |   |   |   |   |   |   |   |   |   |   |
|                              | DL spreading code id #m | - | o | - | - | o | - | - | - | - | - |   |
| Execution Time               | Execution Time          | - | - | - | - | - | m | - | - | - | - |   |
| Offset Values                | Slot offset             | m | - | - | - | - | - | - | - | - | - |   |
|                              | Frame offset            | m | - | - | - | - | - | - | - | - | - |   |
| Power Control Info           | Initial DL Power        | m | - | - | - | - | - | - | - | - | - | For Initial DL Power Setting                |
|                              | DL Power Range          | - | - | - | - | - | - | - | - | - | - | For Correcting DL Power Drifting during DHO |
| Outerloop Power Control Info | Target UL Eb/lo         | m | - | - | - | - | - | - | - | - | - | For L1 Power Control                        |
| Cause                        | Cause                   | - | - | m | - | - | - | m | - | - | - |   |

\*1,\*2: Same as the previous.

## RAB Reconfiguration

| Parameter Category                     | Iub Parameters        | Iub Message   |   |  |   |   | Note                            |
|--|-----------------------|---|---|--|---|---|---------------------------------|
|  |                       | DCH to DCH  |   |  |   |   |                                 |
|  |                       | RA<br>DIO<br>LIN<br>K<br>RE<br>CO<br>NFI<br>GU<br>RAT<br>ION<br>PRE<br>PAR<br>E | RA<br>DIO<br>LIN<br>K<br>RE<br>CO<br>NFI<br>GU<br>RAT<br>ION<br>REA<br>DY | RA<br>DIO<br>LIN<br>K<br>RE<br>CO<br>NFI<br>GU<br>RAT<br>ION<br>CO<br>MMI<br>T | RA<br>DIO<br>LIN<br>K<br>RE<br>CO<br>NFI<br>GU<br>RAT<br>ION<br>FAI<br>LUR<br>E | RA<br>DIO<br>LIN<br>K<br>RE<br>CO<br>NFI<br>GU<br>RAT<br>ION<br>CA<br>NC<br>EL<br>(FF<br>S) |                                 |
| Transport CH Info                      | No. of DCHs           | m   | -   | -  | -   | -   |                                 |
|  | DCH ID (# 1)          | m   | -   | -  | -   | -   | DCH ID or each DCH              |
|  | TFS (for DCH ID# 1)   | m   | -   | -  | -   | -   | Set TFS when it is required     |
|  | :                     |   |   |  |   |   |                                 |
|  | DCH ID (# n)          | m   | -   | -  | -   | -   |                                 |
|  | TFS (for DCH ID# n)   | m   | -   | -  | -   | -   |                                 |
|  | TFCS (for DCHs)       | m   | -   | -  | -   | -   | Set TFCS per UE                 |
| Transport Layer Addressing Information | No. of DCHs           | -   | m   | -  | -   | -   |                                 |
|  | DCH ID (# 1)          | -   | m   | -  | -   | -   |                                 |
|  | ATM Binding ID        | -   | m   | -  | -   | -   | (TTC) 1 Binding ID for 1 DCH *1 |
|  | ATM Address           | -   | o   | -  | -   | -   |                                 |
|  | :                     |   |   |  |   |   |                                 |
|  | DCH ID (# n)          | -   | m   | -  | -   | -   |                                 |
|  | ATM Binding ID        | -   | m   | -  | -   | -   |                                 |
|  | ATM Address           | -   | o   | -  | -   | -   |                                 |
| Radio Frequency Info                   | Radio Frequency       | -   | -   | -  | -   | -   | Set Radio Frequency per UE      |
|  | UL Interference Level | -   | -   | -  | -   | -   |                                 |
| UL Radio Resources                     | UL scrambling code    | -   | -   | -  | -   | -   | Set UL Scrambling Code per UE   |

|                    |                            |   |   |   |   |   |   |
|--------------------|----------------------------|---|---|---|---|---|---|
|                    | UL spreading code type     | m | - | - | - | - |   |
|                    | No. of UL spreading code   | m | - | - | - | - |   |
|                    | UL spreading code id(s)    | m | - | - | - | - |   |
| DL Radio Resources | DL spreading code type     | m | - | - | - | - | Same code type for all Radio Links          |
|                    | No. of DL spreading code   | m | - | - | - | - | Same number of codes for all Radio Links    |
|                    | No. of Radio Links         | m | - | - | - | - |   |
|                    | Radio Link ID              | m | - | - | - | - |   |
|                    | Cell ID                    | - | - | - | - | - |   |
|                    | Soft Combination Indicator | - | - | - | - | - | Indicates May, Must, Must not               |
|                    | Phase Difference           | - | - | - | - | - |   |
|                    | :                          |   |   |   |   |   |   |
|                    | Radio Link ID              | o | - | - | - | - |   |
|                    | Cell ID                    | - | - | - | - | - |   |
|                    | Soft Combination Indicator | - | - | - | - | - |   |
|                    | Phase Difference           | - | - | - | - | - |   |
| DL Radio Resources | No. of Radio Links         | - | m | - | - | - |   |
|                    | Radio Link ID              | - | m | - | - | - |   |
|                    | Neighbor Cell Information  | - | - | - | - | - | FFS*2                                       |
|                    | No. of DL spreading code   | - | m | - | - | - |   |
|                    | DL spreading code id #1    | - | m | - | - | - |   |
|                    | :                          |   |   |   |   |   |   |
|                    | DL spreading code id #m    | - | m | - | - | - |   |
|                    | :                          |   |   |   |   |   |   |
|                    | Radio Link ID              | - | o | - | - | - |   |
|                    | Neighbor Cell Information  | - | - | - | - | - | FFS   |
|                    | No. of DL spreading code   | - | o | - | - | - |   |
|                    | DL spreading code id #1    | - | o | - | - | - |   |
|                    | :                          |   |   |   |   |   |   |
|                    | DL spreading code id #m    | - | o | - | - | - |   |
| Execution Time     | Execution Time             | - | - | m | - | - |   |
| Offset Values      | Slot offset                | - | - | - | - | - |   |
|                    | Frame offset               | - | - | - | - | - |   |
| Power Control Info | Initial DL Power           | - | - | - | - | - | For Initial DL Power Setting                |
|                    | DL Power Range             | - | - | - | - | - | For Correcting DL Power Drifting during DHO |



|                              |                 |   |   |   |   |   |                      |
|------------------------------|-----------------|---|---|---|---|---|----------------------|
| Outerloop Power Control Info | Target UL Eb/lo | - | - | - | - | - | For L1 Power Control |
| Cause                        | Cause           | - | - | - | m | - |                      |

\*1,\*2: Same as the previous.

## RAB Release

| Parameter Category                     | Iub Parameters        | Iub Message   |   |  |   |   |   |   | Note                            |
|--|-----------------------|---|---|--|---|---|---|---|---------------------------------|
|  |                       | DCH to DCH  |   |  |   |   | DCH to RA/FACH                            |   |                                 |
|  |                       | RA<br>DIO<br>LIN<br>K<br>RE<br>CO<br>NFI<br>GU<br>RAT<br>ION<br>PRE<br>PAR<br>E | RA<br>DIO<br>LIN<br>K<br>RE<br>CO<br>NFI<br>GU<br>RAT<br>ION<br>REA<br>DY | RA<br>DIO<br>LIN<br>K<br>RE<br>CO<br>NFI<br>GU<br>RAT<br>ION<br>CO<br>MMI<br>T | RA<br>DIO<br>LIN<br>K<br>RE<br>CO<br>NFI<br>GU<br>RAT<br>ION<br>FAI<br>LUR<br>E | RA<br>DIO<br>LIN<br>K<br>RE<br>CO<br>NFI<br>GU<br>RAT<br>ION<br>CA<br>NC<br>EL<br>(FF<br>S) | RA<br>DIO<br>LIN<br>K<br>DEL<br>ETI<br>ON | RA<br>DIO<br>LIN<br>K<br>DEL<br>ETI<br>ON<br>RES<br>PO<br>NSE |                                 |
| Transport CH Info                      | No. of DCHs           | m   | -   | -  | -   | -   | -   | -   |                                 |
|  | DCH ID (# 1)          | m   | -   | -  | -   | -   | -   | -   | DCH ID or each DCH              |
|  | TFS (for DCH ID# 1)   | -   | -   | -  | -   | -   | -   | -   | Set TFS when it is required     |
|  | :                     |   |   |  |   |   |   |   |                                 |
|  | DCH ID (# n)          | m   | -   | -  | -   | -   | -   | -   |                                 |
|  | TFS (for DCH ID# n)   | -   | -   | -  | -   | -   | -   | -   |                                 |
|  | TFCS (for DCHs)       | m   | -   | -  | -   | -   | -   | -   | Set TFCS per UE                 |
| Transport Layer Addressing Information | No. of DCHs           | -   | -   | -  | -   | -   | -   | -   |                                 |
|  | DCH ID (# 1)          | -   | -   | -  | -   | -   | -   | -   |                                 |
|  | ATM Binding ID        | -   | -   | -  | -   | -   | -   | -   | (TTC) 1 Binding ID for 1 DCH *1 |
|  | ATM Address           | -   | -   | -  | -   | -   | -   | -   |                                 |
|  | :                     |   |   |  |   |   |   |   |                                 |
|  | DCH ID (# n)          | -   | -   | -  | -   | -   | -   | -   |                                 |
|  | ATM Binding ID        | -   | -   | -  | -   | -   | -   | -   |                                 |
|  | ATM Address           | -   | -   | -  | -   | -   | -   | -   |                                 |
| Radio Frequency Info                   | Radio Frequency       | -   | -   | -  | -   | -   | -   | -   | Set Radio Frequency per UE      |
|  | UL Interference Level | -   | -   | -  | -   | -   | -   | -   |                                 |

|                    |                            |   |   |   |   |   |   |   |   |
|--------------------|----------------------------|---|---|---|---|---|---|---|---|
| UL Radio Resources | UL scrambling code         | - | - | - | - | - | - | - | Set UL Scrambling Code per UE               |
|                    | UL spreading code type     | m | - | - | - | - | - | - |   |
|                    | No. of UL spreading code   | m | - | - | - | - | - | - |   |
|                    | UL spreading code id(s)    | m | - | - | - | - | - | - |   |
| DL Radio Resources | DL spreading code type     | m | - | - | - | - | - | - | Same code type for all Radio Links          |
|                    | No. of DL spreading code   | m | - | - | - | - | - | - | Same number of codes for all Radio Links    |
|                    | No. of Radio Links         | m | - | - | - | - | m | - |   |
|                    | Radio Link ID              | m | - | - | - | - | m | - |   |
|                    | Cell ID                    | - | - | - | - | - | - | - |   |
|                    | Soft Combination Indicator | - | - | - | - | - | - | - | Indicates May, Must, Must not               |
|                    | Phase Difference           | - | - | - | - | - | - | - |   |
|                    | :                          |   |   |   |   |   |   |   |   |
|                    | Radio Link ID              | o | - | - | - | - | o | - |   |
|                    | Cell ID                    | - | - | - | - | - | - | - |   |
|                    | Soft Combination Indicator | - | - | - | - | - | - | - |   |
|                    | Phase Difference           | - | - | - | - | - | - | - |   |
| DL Radio Resources | No. of Radio Links         | - | m | - | - | - | - | - |   |
|                    | Radio Link ID              | - | m | - | - | - | - | - |   |
|                    | Neighbor Cell Information  | - | - | - | - | - | - | - | FFS*2                                       |
|                    | No. of DL spreading code   | - | m | - | - | - | - | - |   |
|                    | DL spreading code id #1    | - | m | - | - | - | - | - |   |
|                    | :                          |   |   |   |   |   |   |   |   |
|                    | DL spreading code id #m    | - | m | - | - | - | - | - |   |
|                    | :                          |   |   |   |   |   |   |   |   |
|                    | Radio Link ID              | - | o | - | - | - | - | - |   |
|                    | Neighbor Cell Information  | - | - | - | - | - | - | - | FFS   |
|                    | No. of DL spreading code   | - | o | - | - | - | - | - |   |
|                    | DL spreading code id #1    | - | o | - | - | - | - | - |   |
|                    | :                          |   |   |   |   |   |   |   |   |
|                    | DL spreading code id #m    | - | o | - | - | - | - | - |   |
| Execution Time     | Execution Time             | - | - | m | - | - | - | - |   |
| Offset Values      | Slot offset                | - | - | - | - | - | - | - |   |
|                    | Frame offset               | - | - | - | - | - | - | - |   |
| Power Control Info | Initial DL Power           | - | - | - | - | - | - | - | For Initial DL Power Setting                |
|                    | DL Power Range             | - | - | - | - | - | - | - | For Correcting DL Power Drifting during DHO |

|                              |                 |   |   |   |   |   |   |   |   |                      |
|------------------------------|-----------------|---|---|---|---|---|---|---|---|----------------------|
| Outerloop Power Control Info | Target UL Eb/lo | - | - | - | - | - | - | - | - | For L1 Power Control |
| Cause                        | Cause           | - | - | - | m | - | - | - |   |                      |

\*1,\*2: Same as the previous.

## RRC Connection Release

| Parameter Category                     | Sub Parameters           | Sub Message                               |   | Note                               |
|--|--------------------------|---|---|------------------------------------|
|  |                          | DCH to IDLE                               |   |                                    |
|  |                          | RA<br>DIO<br>LIN<br>K<br>DEL<br>ETI<br>ON | RA<br>DIO<br>LIN<br>K<br>DEL<br>ETI<br>ON<br>RES<br>PO<br>NSE |                                    |
| Transport CH Info                      | No. of DCHs              | -   | -   |                                    |
|  | DCH ID (# 1)             | -   | -   | DCH ID or each DCH                 |
|  | TFS (for DCH ID# 1)      | -   | -   | Set TFS when it is required        |
|  | :                        |   |   |                                    |
|  | DCH ID (# n)             | -   | -   |                                    |
|  | TFS (for DCH ID# n)      | -   | -   |                                    |
|  | TFCS (for DCHs)          | -   | -   | Set TFCS per UE                    |
| Transport Layer Addressing Information | No. of DCHs              | -   | -   |                                    |
|  | DCH ID (# 1)             | -   | -   |                                    |
|  | ATM Binding ID           | -   | -   | (TTC) 1 Binding ID for 1 DCH *1    |
|  | ATM Address              | -   | -   |                                    |
|  | :                        |   |   |                                    |
|  | DCH ID (# n)             | -   | -   |                                    |
|  | ATM Binding ID           | -   | -   |                                    |
|  | ATM Address              | -   | -   |                                    |
| Radio Frequency Info                   | Radio Frequency          | -   | -   | Set Radio Frequency per UE         |
|  | UL Interference Level    | -   | -   |                                    |
| UL Radio Resources                     | UL scrambling code       | -   | -   | Set UL Scrambling Code per UE      |
|  | UL spreading code type   | -   | -   |                                    |
|  | No. of UL spreading code | -   | -   |                                    |
|  | UL spreading code id(s)  | -   | -   |                                    |
| DL Radio Resources                     | DL spreading code type   | -   | -   | Same code type for all Radio Links |

|                              |                            |   |   |   |
|------------------------------|----------------------------|---|---|---|
|                              | No. of DL spreading code   | - | - | Same number of codes for all Radio Links    |
|                              | No. of Radio Links         | m | - |   |
|                              | Radio Link ID              | m | - |   |
|                              | Cell ID                    | - | - |   |
|                              | Soft Combination Indicator | - | - | Indicates May, Must, Must not               |
|                              | Phase Difference           | - | - |   |
|                              | :                          |   |   |   |
|                              | Radio Link ID              | o | - |   |
|                              | Cell ID                    | - | - |   |
|                              | Soft Combination Indicator | - | - |   |
|                              | Phase Difference           | - | - |   |
| DL Radio Resources           | No. of Radio Links         | - | - |   |
|                              | Radio Link ID              | - | - |   |
|                              | Neighbor Cell Information  | - | - | <b>FFS*2</b>                                |
|                              | No. of DL spreading code   | - | - |   |
|                              | DL spreading code id #1    | - | - |   |
|                              | :                          |   |   |   |
|                              | DL spreading code id #m    | - | - |   |
|                              | :                          |   |   |   |
|                              | Radio Link ID              | - | - |   |
|                              | Neighbor Cell Information  | - | - | FFS   |
|                              | No. of DL spreading code   | - | - |   |
|                              | DL spreading code id #1    | - | - |   |
|                              | :                          |   |   |   |
|                              | DL spreading code id #m    | - | - |   |
| Execution Time               | Execution Time             | - | - |   |
| Offset Values                | Slot offset                | - | - |   |
|                              | Frame offset               | - | - |   |
| Power Control Info           | Initial DL Power           | - | - | For Initial DL Power Setting                |
|                              | DL Power Range             | - | - | For Correcting DL Power Drifting during DHO |
| Outerloop Power Control Info | Target UL Eb/lo            | - | - | For L1 Power Control                        |

\*1,\*2: Same as the previous.

## Transport CH Reconfiguration

| Parameter Category                     | Iub Parameters      | Iub Message  |  |   |   |   |  |   |   |   |   | Note                            |
|--|---------------------|--|--|---|---|---|--|---|---|---|---|---------------------------------|
|  |                     | RA/FACH to DCH   |  |   | DCH to DCH  |   |  |   |   |   | DCH to RA/FACH  |                                 |
|  |                     | R<br>A<br>D<br>I<br>O<br><br>L<br>I<br>N<br>K<br>S<br>E<br>T<br>U<br>P | RA<br>DIO<br>LIN<br>K<br>S<br>E<br>T<br>U<br>P<br>R<br>E<br>S<br>P<br>O<br>N<br>S<br>E | RA<br>DIO<br>LIN<br>K<br>S<br>E<br>T<br>U<br>P<br>F<br>A<br>I<br>L<br>U<br>R<br>E | RA<br>DIO<br>LIN<br>K<br>R<br>E<br>C<br>O<br>N<br>F<br>I<br>G<br>U<br>R<br>A<br>T<br>I<br>O<br>N<br>P<br>R<br>E<br>P<br>A<br>R<br>E | RA<br>DIO<br>LIN<br>K<br>R<br>E<br>C<br>O<br>N<br>F<br>I<br>G<br>U<br>R<br>A<br>T<br>I<br>O<br>N<br>R<br>E<br>A<br>D<br>Y | RA<br>DIO<br>LIN<br>K<br>R<br>E<br>C<br>O<br>N<br>F<br>I<br>G<br>U<br>R<br>A<br>T<br>I<br>O<br>N<br>C<br>O<br>M<br>M<br>I<br>T | RA<br>DIO<br>LIN<br>K<br>R<br>E<br>C<br>O<br>N<br>F<br>I<br>G<br>U<br>R<br>A<br>T<br>I<br>O<br>N<br>F<br>A<br>I<br>L<br>U<br>R<br>E | RA<br>DIO<br>LIN<br>K<br>R<br>E<br>C<br>O<br>N<br>F<br>I<br>G<br>U<br>R<br>A<br>T<br>I<br>O<br>N<br>C<br>A<br>N<br>C<br>E<br>L<br>(F<br>F<br>S) | R<br>A<br>D<br>I<br>O<br><br>L<br>I<br>N<br>K<br>D<br>E<br>L<br>E<br>T<br>I<br>O<br>N | RA<br>DIO<br>LIN<br>K<br>D<br>E<br>L<br>E<br>T<br>I<br>O<br>N<br>R<br>E<br>S<br>P<br>O<br>N<br>S<br>E |                                 |
| Transport CH Info                      | No. of DCHs         | m  | -  | -   | m   | -   | -  | -   | -   | -   | -   |                                 |
|  | DCH ID (# 1)        | m  | -  | -   | m   | -   | -  | -   | -   | -   | -   | DCH ID or each DCH              |
|  | TFS (for DCH ID# 1) | m  | -  | -   | m   | -   | -  | -   | -   | -   | -   | Set TFS when it is required     |
|  | :                   |  |  |   |   |   |  |   |   |   |   |                                 |
|  | DCH ID (# n)        | m  | -  | -   | m   | -   | -  | -   | -   | -   | -   |                                 |
|  | TFS (for DCH ID# n) | m  | -  | -   | m   | -   | -  | -   | -   | -   | -   |                                 |
|  | TFCS (for DCHs)     | m  | -  | -   | m   | -   | -  | -   | -   | -   | -   | Set TFCS per UE                 |
| Transport Layer Addressing Information | No. of DCHs         | -  | m  | -   | -   | m   | -  | -   | -   | -   | -   |                                 |
|  | DCH ID (# 1)        | -  | m  | -   | -   | m   | -  | -   | -   | -   | -   |                                 |
|  | ATM Binding ID      | -  | m  | -   | -   | m   | -  | -   | -   | -   | -   | (TTC) 1 Binding ID for 1 DCH *1 |
|  | ATM Address         | -  | o  | -   | -   | o   | -  | -   | -   | -   | -   |                                 |
|  | :                   |  |  |   |   |   |  |   |   |   |   |                                 |
|  | DCH ID (# n)        | -  | m  | -   | -   | m   | -  | -   | -   | -   | -   |                                 |
|  | ATM Binding ID      | -  | m  | -   | -   | m   | -  | -   | -   | -   | -   |                                 |

|                      |                            |   |   |   |   |   |   |   |   |   |   |  |
|----------------------|----------------------------|---|---|---|---|---|---|---|---|---|---|--|
|                      | ATM Address                | - | o | - | - | o | - | - | - | - | - |  |
| Radio Frequency Info | Radio Frequency            | m | - | - | - | - | - | - | - | - | - | Set Radio Frequency per UE               |
|                      | UL Interference Level      | - | m | - | - | - | - | - | - | - | - |  |
| UL Radio Resources   | UL scrambling code         | m | - | - | - | - | - | - | - | - | - | Set UL Scrambling Code per UE            |
|                      | UL spreading code type     | m | - | - | m | - | - | - | - | - | - |  |
|                      | No. of UL spreading code   | m | - | - | m | - | - | - | - | - | - |  |
|                      | UL spreading code id(s)    | m | - | - | m | - | - | - | - | - | - |  |
| DL Radio Resources   | DL spreading code type     | m | - | - | m | - | - | - | - | - | - | Same code type for all Radio Links       |
|                      | No. of DL spreading code   | m | - | - | m | - | - | - | - | - | - | Same number of codes for all Radio Links |
|                      | No. of Radio Links         | m | - | - | m | - | - | - | - | m | - |  |
|                      | Radio Link ID              | m | - | - | m | - | - | - | - | m | - |  |
|                      | Cell ID                    | m | - | - | - | - | - | - | - | - | - |  |
|                      | Soft Combination Indicator | - | - | - | - | - | - | - | - | - | - | Indicates May, Must, Must not            |
|                      | Phase Difference           | m | - | - | - | - | - | - | - | - | - |  |
|                      | :                          |   |   |   |   |   |   |   |   |   |   |  |
|                      | Radio Link ID              | o | - | - | o | - | - | - | - | o | - |  |
|                      | Cell ID                    | o | - | - | - | - | - | - | - | - | - |  |
|                      | Soft Combination Indicator | o | - | - | - | - | - | - | - | - | - |  |
|                      | Phase Difference           | o | - | - | - | - | - | - | - | - | - |  |
| DL Radio Resources   | No. of Radio Links         | - | m | - | - | m | - | - | - | - | - |  |
|                      | Radio Link ID              | - | m | - | - | m | - | - | - | - | - |  |
|                      | Neighbor Cell Information  | - | m | - | - | - | - | - | - | - | - | FFS*2                                    |
|                      | No. of DL spreading code   | - | m | - | - | m | - | - | - | - | - |  |
|                      | DL spreading code id #1    | - | m | - | - | m | - | - | - | - | - |  |
|                      | :                          |   |   |   |   |   |   |   |   |   |   |  |
|                      | DL spreading code id #m    | - | m | - | - | m | - | - | - | - | - |  |
|                      | :                          |   |   |   |   |   |   |   |   |   |   |  |
|                      | Radio Link ID              | - | o | - | - | o | - | - | - | - | - |  |
|                      | Neighbor Cell Information  | - | o | - | - | - | - | - | - | - | - | FFS                                      |
|                      | No. of DL spreading code   | - | o | - | - | o | - | - | - | - | - |  |
|                      | DL spreading code id #1    | - | o | - | - | o | - | - | - | - | - |  |
|                      | :                          |   |   |   |   |   |   |   |   |   |   |  |
|                      | DL spreading code id #m    | - | o | - | - | o | - | - | - | - | - |  |
| Execution Time       | Execution Time             | - | - | - | - | - | m | - | - | - | - |  |



|                              |                  |   |   |   |   |   |   |   |   |   |   |   |
|------------------------------|------------------|---|---|---|---|---|---|---|---|---|---|---|
| Offset Values                | Slot offset      | m | - | - | - | - | - | - | - | - | - |   |
|                              | Frame offset     | m | - | - | - | - | - | - | - | - | - |   |
| Power Control Info           | Initial DL Power | m | - | - | - | - | - | - | - | - | - | For Initial DL Power Setting                |
|                              | DL Power Range   | - | - | - | - | - | - | - | - | - | - | For Correcting DL Power Drifting during DHO |
| Outerloop Power Control Info | Target UL Eb/lo  | m | - | - | - | - | - | - | - | - | - | For L1 Power Control                        |
| Cause                        | Cause            | - | - | m | - | - | - | m | - | - | - |   |

\*1,\*2: Same as the previous.

## Physical CH Reconfiguration

| Parameter Category                     | Iub Parameters      | Iub Message  |  |   |   |   |  |   |   |   |   | Note                            |
|--|---------------------|--|--|---|---|---|--|---|---|---|---|---------------------------------|
|  |                     | RA/FACH to DCH   |  |   | DCH to DCH  |   |  |   |   |   | DCH to RA/FACH  |                                 |
|  |                     | R<br>A<br>D<br>I<br>O<br><br>L<br>I<br>N<br>K<br>S<br>E<br>T<br>U<br>P | RA<br>D<br>I<br>O<br>L<br>I<br>N<br>K<br>S<br>E<br>T<br>U<br>P<br>R<br>E<br>S<br>P<br>O<br>N<br>S<br>E | RA<br>D<br>I<br>O<br>L<br>I<br>N<br>K<br>S<br>E<br>T<br>U<br>P<br>F<br>A<br>I<br>L<br>U<br>R<br>E | RA<br>D<br>I<br>O<br>L<br>I<br>N<br>K<br>R<br>E<br>C<br>O<br>N<br>F<br>I<br>G<br>U<br>R<br>A<br>T<br>I<br>O<br>N<br>P<br>R<br>E<br>P<br>A<br>R<br>E | RA<br>D<br>I<br>O<br>L<br>I<br>N<br>K<br>R<br>E<br>C<br>O<br>N<br>F<br>I<br>G<br>U<br>R<br>A<br>T<br>I<br>O<br>N<br>R<br>E<br>A<br>D<br>Y | RA<br>D<br>I<br>O<br>L<br>I<br>N<br>K<br>R<br>E<br>C<br>O<br>N<br>F<br>I<br>G<br>U<br>R<br>A<br>T<br>I<br>O<br>N<br>C<br>O<br>M<br>M<br>I<br>T | RA<br>D<br>I<br>O<br>L<br>I<br>N<br>K<br>R<br>E<br>C<br>O<br>N<br>F<br>I<br>G<br>U<br>R<br>A<br>T<br>I<br>O<br>N<br>F<br>A<br>I<br>L<br>U<br>R<br>E | RA<br>D<br>I<br>O<br>L<br>I<br>N<br>K<br>R<br>E<br>C<br>O<br>N<br>F<br>I<br>G<br>U<br>R<br>A<br>T<br>I<br>O<br>N<br>C<br>A<br>N<br>C<br>E<br>L<br>(F<br>F<br>S) | R<br>A<br>D<br>I<br>O<br>L<br>I<br>N<br>K<br>D<br>E<br>L<br>E<br>T<br>I<br>O<br>N | RA<br>D<br>I<br>O<br>L<br>I<br>N<br>K<br>D<br>E<br>L<br>E<br>T<br>I<br>O<br>N<br>R<br>E<br>S<br>P<br>O<br>N<br>S<br>E |                                 |
| Transport CH Info                      | No. of DCHs         | m  | -  | -   | -   | -   | -  | -   | -   | -   | -   |                                 |
|  | DCH ID (# 1)        | m  | -  | -   | -   | -   | -  | -   | -   | -   | -   | DCH ID or each DCH              |
|  | TFS (for DCH ID# 1) | m  | -  | -   | -   | -   | -  | -   | -   | -   | -   | Set TFS when it is required     |
|  | :                   |  |  |   | -   |   |  |   |   |   |   |                                 |
|  | DCH ID (# n)        | m  | -  | -   | -   | -   | -  | -   | -   | -   | -   |                                 |
|  | TFS (for DCH ID# n) | m  | -  | -   | -   | -   | -  | -   | -   | -   | -   |                                 |
|  | TFCS (for DCHs)     | m  | -  | -   | -   | -   | -  | -   | -   | -   | -   | Set TFCS per UE                 |
| Transport Layer Addressing Information | No. of DCHs         | -  | m  | -   | -   | -   | -  | -   | -   | -   | -   |                                 |
|  | DCH ID (# 1)        | -  | m  | -   | -   | -   | -  | -   | -   | -   | -   |                                 |
|  | ATM Binding ID      | -  | m  | -   | -   | -   | -  | -   | -   | -   | -   | (TTC) 1 Binding ID for 1 DCH *1 |
|  | ATM Address         | -  | o  | -   | -   | -   | -  | -   | -   | -   | -   |                                 |
|  | :                   |  |  |   |   |   |  |   |   |   |   |                                 |
|  | DCH ID (# n)        | -  | m  | -   | -   | -   | -  | -   | -   | -   | -   |                                 |
|  | ATM Binding ID      | -  | m  | -   | -   | -   | -  | -   | -   | -   | -   |                                 |

|                      |                            |   |   |   |   |   |   |   |   |   |   |  |
|----------------------|----------------------------|---|---|---|---|---|---|---|---|---|---|--|
|                      | ATM Address                | - | o | - | - | - | - | - | - | - | - |  |
| Radio Frequency Info | Radio Frequency            | m | - | - | - | - | - | - | - | - | - | Set Radio Frequency per UE               |
|                      | UL Interference Level      | - | m | - | - | - | - | - | - | - | - |  |
| UL Radio Resources   | UL scrambling code         | m | - | - | o | - | - | - | - | - | - | Set UL Scrambling Code per UE            |
|                      | UL spreading code type     | m | - | - | o | - | - | - | - | - | - |  |
|                      | No. of UL spreading code   | m | - | - | o | - | - | - | - | - | - |  |
|                      | UL spreading code id(s)    | m | - | - | o | - | - | - | - | - | - |  |
| DL Radio Resources   | DL spreading code type     | m | - | - | o | - | - | - | - | - | - | Same code type for all Radio Links       |
|                      | No. of DL spreading code   | m | - | - | o | - | - | - | - | - | - | Same number of codes for all Radio Links |
|                      | No. of Radio Links         | m | - | - | o | - | - | - | - | m | - |  |
|                      | Radio Link ID              | m | - | - | o | - | - | - | - | m | - |  |
|                      | Cell ID                    | m | - | - | - | - | - | - | - | - | - |  |
|                      | Soft Combination Indicator | - | - | - | - | - | - | - | - | - | - | Indicates May, Must, Must not            |
|                      | Phase Difference           | m | - | - | - | - | - | - | - | - | - |  |
|                      | :                          |   |   |   |   |   |   |   |   |   |   |  |
|                      | Radio Link ID              | o | - | - | o | - | - | - | - | o | - |  |
|                      | Cell ID                    | o | - | - | - | - | - | - | - | - | - |  |
|                      | Soft Combination Indicator | o | - | - | - | - | - | - | - | - | - |  |
|                      | Phase Difference           | o | - | - | - | - | - | - | - | - | - |  |
| DL Radio Resources   | No. of Radio Links         | - | m | - | - | m | - | - | - | - | - |  |
|                      | Radio Link ID              | - | m | - | - | m | - | - | - | - | - |  |
|                      | Neighbor Cell Information  | - | m | - | - | - | - | - | - | - | - | FFS*2                                    |
|                      | No. of DL spreading code   | - | m | - | - | m | - | - | - | - | - |  |
|                      | DL spreading code id #1    | - | m | - | - | m | - | - | - | - | - |  |
|                      | :                          |   |   |   |   |   |   |   |   |   |   |  |
|                      | DL spreading code id #m    | - | m | - | - | m | - | - | - | - | - |  |
|                      | :                          |   |   |   |   |   |   |   |   |   |   |  |
|                      | Radio Link ID              | - | o | - | - | o | - | - | - | - | - |  |
|                      | Neighbor Cell Information  | - | o | - | - | - | - | - | - | - | - | FFS                                      |
|                      | No. of DL spreading code   | - | o | - | - | o | - | - | - | - | - |  |
|                      | DL spreading code id #1    | - | o | - | - | o | - | - | - | - | - |  |
|                      | :                          |   |   |   |   |   |   |   |   |   |   |  |
|                      | DL spreading code id #m    | - | o | - | - | o | - | - | - | - | - |  |
| Execution Time       | Execution Time             | - | - | - | - | - | m | - | - | - | - |  |

|                              |                  |   |   |   |   |   |   |   |   |   |   |   |
|------------------------------|------------------|---|---|---|---|---|---|---|---|---|---|---|
| Offset Values                | Slot offset      | m | - | - | - | - | - | - | - | - | - |   |
|                              | Frame offset     | m | - | - | - | - | - | - | - | - | - |   |
| Power Control Info           | Initial DL Power | m | - | - | - | - | - | - | - | - | - | For Initial DL Power Setting                |
|                              | DL Power Range   | - | - | - | - | - | - | - | - | - | - | For Correcting DL Power Drifting during DHO |
| Outerloop Power Control Info | Target UL Eb/lo  | m | - | - | - | - | - | - | - | - | - | For L1 Power Control                        |
| Cause                        | Cause            | - | - | m | - | - | - | m | - | - | - |   |

\*1,\*2: Same as the previous.

### Hard Handover (Inter-NodeB)

| Parameter Category                     | Iub Parameters           | Iub Message                        |  |   |   |   | Note                               |
|--|--------------------------|------------------------------------|--|---|---|---|------------------------------------|
|  |                          | RA<br>DIO<br>LIN<br>K<br>SET<br>UP | RA<br>DIO<br>LIN<br>K<br>SET<br>UP<br>RES<br>PO<br>NSE | RA<br>DIO<br>LIN<br>K<br>SET<br>UP<br>FAI<br>LUR<br>E | RA<br>DIO<br>LIN<br>K<br>DEL<br>ETI<br>ON | RA<br>DIO<br>LIN<br>K<br>DEL<br>ETI<br>ON<br>RES<br>PO<br>NSE |                                    |
| Transport CH Info                      | No. of DCHs              | m                                  | -  | -   | -   | -   |                                    |
|  | DCH ID (# 1)             | m                                  | -  | -   | -   | -   | DCH ID or each DCH                 |
|  | TFS (for DCH ID# 1)      | m                                  | -  | -   | -   | -   | Set TFS when it is required        |
|  | :                        |                                    |  |   |   |   |                                    |
|  | DCH ID (# n)             | m                                  | -  | -   | -   | -   |                                    |
|  | TFS (for DCH ID# n)      | m                                  | -  | -   | -   | -   |                                    |
|  | TFCS (for DCHs)          | m                                  | -  | -   | -   | -   | Set TFCS per UE                    |
| Transport Layer Addressing Information | No. of DCHs              | -                                  | m  | -   | -   | -   |                                    |
|  | DCH ID (# 1)             | -                                  | m  | -   | -   | -   |                                    |
|  | ATM Binding ID           | -                                  | m  | -   | -   | -   | (TTC) 1 Binding ID for 1 DCH *1    |
|  | ATM Address              | -                                  | o  | -   | -   | -   |                                    |
|  | :                        |                                    |  |   |   |   |                                    |
|  | DCH ID (# n)             | -                                  | m  | -   | -   | -   |                                    |
|  | ATM Binding ID           | -                                  | m  | -   | -   | -   |                                    |
|  | ATM Address              | -                                  | o  | -   | -   | -   |                                    |
| Radio Frequency Info                   | Radio Frequency          | m                                  | -  | -   | -   | -   | Set Radio Frequency per UE         |
|  | UL Interference Level    | -                                  | m  | -   | -   | -   |                                    |
| UL Radio Resources                     | UL scrambling code       | m                                  | -  | -   | -   | -   | Set UL Scrambling Code per UE      |
|  | UL spreading code type   | m                                  | -  | -   | -   | -   |                                    |
|  | No. of UL spreading code | m                                  | -  | -   | -   | -   |                                    |
|  | UL spreading code id(s)  | m                                  | -  | -   | -   | -   |                                    |
| DL Radio Resources                     | DL spreading code type   | m                                  | -  | -   | -   | -   | Same code type for all Radio Links |

|                              |                            |   |   |   |   |   |   |
|------------------------------|----------------------------|---|---|---|---|---|---|
|                              | No. of DL spreading code   | m | - | - | - | - | Same number of codes for all Radio Links    |
|                              | No. of Radio Links         | m | - | - | m | - |   |
|                              | Radio Link ID              | m | - | - | m | - |   |
|                              | Cell ID                    | m | - | - | - | - |   |
|                              | Soft Combination Indicator | - | - | - | - | - | Indicates May, Must, Must not               |
|                              | Phase Difference           | m | - | - | - | - |   |
|                              | :                          |   |   |   |   |   |   |
|                              | Radio Link ID              | o | - | - | o | - |   |
|                              | Cell ID                    | o | - | - | - | - |   |
|                              | Soft Combination Indicator | o | - | - | - | - |   |
|                              | Phase Difference           | o | - | - | - | - |   |
| DL Radio Resources           | No. of Radio Links         | - | m | - | - | - |   |
|                              | Radio Link ID              | - | m | - | - | - |   |
|                              | Neighbor Cell Information  | - | m | - | - | - | FFS*2                                       |
|                              | No. of DL spreading code   | - | m | - | - | - |   |
|                              | DL spreading code id #1    | - | m | - | - | - |   |
|                              | :                          |   |   |   |   |   |   |
|                              | DL spreading code id #m    | - | m | - | - | - |   |
|                              | :                          |   |   |   |   |   |   |
|                              | Radio Link ID              | - | o | - | - | - |   |
|                              | Neighbor Cell Information  | - | o | - | - | - | FFS   |
|                              | No. of DL spreading code   | - | o | - | - | - |   |
|                              | DL spreading code id #1    | - | o | - | - | - |   |
|                              | :                          |   |   |   |   |   |   |
|                              | DL spreading code id #m    | - | o | - | - | - |   |
| Execution Time               | Execution Time             | - | - | - | - | - |   |
| Offset Values                | Slot offset                | m | - | - | - | - |   |
|                              | Frame offset               | m | - | - | - | - |   |
| Power Control Info           | Initial DL Power           | m | - | - | - | - | For Initial DL Power Setting                |
|                              | DL Power Range             | - | - | - | - | - | For Correcting DL Power Drifting during DHO |
| Outerloop Power Control Info | Target UL Eb/lo            | m | - | - | - | - | For L1 Power Control                        |
| Cause                        | Cause                      | - | - | m | - | - |   |

\*1,\*2: Same as the previous.

### Hard Handover (Intra-NodeB)

| Parameter Category                     | Iub Parameters           | Iub Message                               |   |  |   |   | Note                               |
|--|--------------------------|---|---|--|---|---|------------------------------------|
|  |                          | RA<br>DIO<br>LIN<br>K<br>AD<br>DITI<br>ON | RA<br>DIO<br>LIN<br>K<br>AD<br>DITI<br>ON<br>RES<br>PO<br>NSE | RA<br>DIO<br>LIN<br>K<br>AD<br>DITI<br>ON<br>FAI<br>LUR<br>E | RA<br>DIO<br>LIN<br>K<br>DEL<br>ETI<br>ON | RA<br>DIO<br>LIN<br>K<br>DEL<br>ETI<br>ON<br>RES<br>PO<br>NSE |                                    |
| Transport CH Info                      | No. of DCHs              | -   | -   | -  | -   | -   |                                    |
|  | DCH ID (# 1)             | -   | -   | -  | -   | -   | DCH ID or each DCH                 |
|  | TFS (for DCH ID# 1)      | -   | -   | -  | -   | -   | Set TFS when it is required        |
|  | :                        |   |   |  |   |   |                                    |
|  | DCH ID (# n)             | -   | -   | -  | -   | -   |                                    |
|  | TFS (for DCH ID# n)      | -   | -   | -  | -   | -   |                                    |
|  | TFCS (for DCHs)          | -   | -   | -  | -   | -   | Set TFCS per UE                    |
| Transport Layer Addressing Information | No. of DCHs              | -   | m   | -  | -   | -   |                                    |
|  | DCH ID (# 1)             | -   | m   | -  | -   | -   |                                    |
|  | ATM Binding ID           | -   | m   | -  | -   | -   | (TTC) 1 Binding ID for 1 DCH *1    |
|  | ATM Address              | -   | o   | -  | -   | -   |                                    |
|  | :                        |   |   |  |   |   |                                    |
|  | DCH ID (# n)             | -   | m   | -  | -   | -   |                                    |
|  | ATM Binding ID           | -   | m   | -  | -   | -   |                                    |
|  | ATM Address              | -   | o   | -  | -   | -   |                                    |
| Radio Frequency Info                   | Radio Frequency          | o   | -   | -  | -   | -   | Set Radio Frequency per UE         |
|  | UL Interference Level    | -   | m   | -  | -   | -   |                                    |
| UL Radio Resources                     | UL scrambling code       | -   | -   | -  | -   | -   | Set UL Scrambling Code per UE      |
|  | UL spreading code type   | -   | -   | -  | -   | -   |                                    |
|  | No. of UL spreading code | -   | -   | -  | -   | -   |                                    |
|  | UL spreading code id(s)  | -   | -   | -  | -   | -   |                                    |
| DL Radio Resources                     | DL spreading code type   | -   | -   | -  | -   | -   | Same code type for all Radio Links |

|                              |                            |   |   |   |   |   |   |
|------------------------------|----------------------------|---|---|---|---|---|---|
|                              | No. of DL spreading code   | - | - | - | - | - | Same number of codes for all Radio Links    |
|                              | No. of Radio Links         | m | - | - | m | - |   |
|                              | Radio Link ID              | m | - | - | m | - |   |
|                              | Cell ID                    | m | - | - | - | - |   |
|                              | Soft Combination Indicator | m | - | - | - | - | Indicates May, Must, Must not               |
|                              | Phase Difference           | m | - | - | - | - |   |
|                              | :                          |   |   |   |   |   |   |
|                              | Radio Link ID              | o | - | - | o | - |   |
|                              | Cell ID                    | o | - | - | - | - |   |
|                              | Soft Combination Indicator | o | - | - | - | - |   |
|                              | Phase Difference           | o | - | - | - | - |   |
| DL Radio Resources           | No. of Radio Links         | - | m | - | - | - |   |
|                              | Radio Link ID              | - | m | - | - | - |   |
|                              | Neighbor Cell Information  | - | m | - | - | - | FFS*2                                       |
|                              | No. of DL spreading code   | - | m | - | - | - |   |
|                              | DL spreading code id #1    | - | m | - | - | - |   |
|                              | :                          |   |   |   |   |   |   |
|                              | DL spreading code id #m    | - | m | - | - | - |   |
|                              | :                          |   |   |   |   |   |   |
|                              | Radio Link ID              | - | o | - | - | - |   |
|                              | Neighbor Cell Information  | - | o | - | - | - | FFS   |
|                              | No. of DL spreading code   | - | o | - | - | - |   |
|                              | DL spreading code id #1    | - | o | - | - | - |   |
|                              | :                          |   |   |   |   |   |   |
|                              | DL spreading code id #m    | - | o | - | - | - |   |
| Execution Time               | Execution Time             | - | - | - | - | - |   |
| Offset Values                | Slot offset                | - | - | - | - | - |   |
|                              | Frame offset               | - | - | - | - | - |   |
| Power Control Info           | Initial DL Power           | - | - | - | - | - | For Initial DL Power Setting                |
|                              | DL Power Range             | - | - | - | - | - | For Correcting DL Power Drifting during DHO |
| Outerloop Power Control Info | Target UL Eb/lo            | - | - | - | - | - | For L1 Power Control                        |
| Cause                        | Cause                      | - | - | m | - | - |   |

\*1,\*2: Same as the previous.



### Handover Radio Link Addition (Inter-NodeB)

| Parameter Category                     | Iub Parameters           | Iub Message                        |  |   | Note                                     |
|--|--------------------------|------------------------------------|--|---|--|
|  |                          | RA<br>DIO<br>LIN<br>K<br>SET<br>UP | RA<br>DIO<br>LIN<br>K<br>SET<br>UP<br>RES<br>PO<br>NSE | RA<br>DIO<br>LIN<br>K<br>SET<br>UP<br>FAI<br>LUR<br>E |  |
| Transport CH Info                      | No. of DCHs              | m                                  | -  | -   |  |
|  | DCH ID (# 1)             | m                                  | -  | -   | DCH ID or each DCH                       |
|  | TFS (for DCH ID# 1)      | m                                  | -  | -   | Set TFS when it is required              |
|  | :                        |                                    |  |   |  |
|  | DCH ID (# n)             | m                                  | -  | -   |  |
|  | TFS (for DCH ID# n)      | m                                  | -  | -   |  |
|  | TFCS (for DCHs)          | m                                  | -  | -   | Set TFCS per UE                          |
| Transport Layer Addressing Information | No. of DCHs              | -                                  | m  | -   |  |
|  | DCH ID (# 1)             | -                                  | m  | -   |  |
|  | ATM Binding ID           | -                                  | m  | -   | (TTC) 1 Binding ID for 1 DCH *1          |
|  | ATM Address              | -                                  | o  | -   |  |
|  | :                        |                                    |  |   |  |
|  | DCH ID (# n)             | -                                  | m  | -   |  |
|  | ATM Binding ID           | -                                  | m  | -   |  |
|  | ATM Address              | -                                  | o  | -   |  |
| Radio Frequency Info                   | Radio Frequency          | m                                  | -  | -   | Set Radio Frequency per UE               |
|  | UL Interference Level    | -                                  | m  | -   |  |
| UL Radio Resources                     | UL scrambling code       | m                                  | -  | -   | Set UL Scrambling Code per UE            |
|  | UL spreading code type   | m                                  | -  | -   |  |
|  | No. of UL spreading code | m                                  | -  | -   |  |
|  | UL spreading code id(s)  | m                                  | -  | -   |  |
| DL Radio Resources                     | DL spreading code type   | m                                  | -  | -   | Same code type for all Radio Links       |
|  | No. of DL spreading code | m                                  | -  | -   | Same number of codes for all Radio Links |

|                              |                            |   |   |   |   |
|------------------------------|----------------------------|---|---|---|---|
|                              | No. of Radio Links         | m | - | - |   |
|                              | Radio Link ID              | m | - | - |   |
|                              | Cell ID                    | m | - | - |   |
|                              | Soft Combination Indicator | - | - | - | Indicates May, Must, Must not               |
|                              | Phase Difference           | m | - | - |   |
|                              | :                          |   |   |   |   |
|                              | Radio Link ID              | o | - | - |   |
|                              | Cell ID                    | o | - | - |   |
|                              | Soft Combination Indicator | o | - | - |   |
|                              | Phase Difference           | o | - | - |   |
| DL Radio Resources           | No. of Radio Links         | - | m | - |   |
|                              | Radio Link ID              | - | m | - |   |
|                              | Neighbor Cell Information  | - | m | - | FFS*2                                       |
|                              | No. of DL spreading code   | - | m | - |   |
|                              | DL spreading code id #1    | - | m | - |   |
|                              | :                          |   |   |   |   |
|                              | DL spreading code id #m    | - | m | - |   |
|                              | :                          |   |   |   |   |
|                              | Radio Link ID              | - | o | - |   |
|                              | Neighbor Cell Information  | - | o | - | FFS   |
|                              | No. of DL spreading code   | - | o | - |   |
|                              | DL spreading code id #1    | - | o | - |   |
|                              | :                          |   |   |   |   |
|                              | DL spreading code id #m    | - | o | - |   |
| Execution Time               | Execution Time             | - | - | - |   |
| Offset Values                | Slot offset                | m | - | - |   |
|                              | Frame offset               | m | - | - |   |
| Power Control Info           | Initial DL Power           | m | - | - | For Initial DL Power Setting                |
|                              | DL Power Range             | - | - | - | For Correcting DL Power Drifting during DHO |
| Outerloop Power Control Info | Target UL Eb/lo            | m | - | - | For L1 Power Control                        |
| Cause                        | Cause                      | - | - | m |   |

\*1,\*2: Same as the previous.

### Handover Radio Link Addition (Intra-NodeB)

| Parameter Category                     | Iub Parameters           | Iub Message                               |   |  | Note                               |
|--|--------------------------|---|---|--|------------------------------------|
|  |                          | RA<br>DIO<br>LIN<br>K<br>AD<br>DITI<br>ON | RA<br>DIO<br>LIN<br>K<br>AD<br>DITI<br>ON<br>RES<br>PO<br>NSE | RA<br>DIO<br>LIN<br>K<br>AD<br>DITI<br>ON<br>FAI<br>LUR<br>E |                                    |
| Transport CH Info                      | No. of DCHs              | -   | -   | -  |                                    |
|  | DCH ID (# 1)             | -   | -   | -  | DCH ID or each DCH                 |
|  | TFS (for DCH ID# 1)      | -   | -   | -  | Set TFS when it is required        |
|  | :                        |   |   |  |                                    |
|  | DCH ID (# n)             | -   | -   | -  |                                    |
|  | TFS (for DCH ID# n)      | -   | -   | -  |                                    |
|  | TFCS (for DCHs)          | -   | -   | -  | Set TFCS per UE                    |
| Transport Layer Addressing Information | No. of DCHs              | -   | m   | -  |                                    |
|  | DCH ID (# 1)             | -   | m   | -  |                                    |
|  | ATM Binding ID           | -   | m   | -  | (TTC) 1 Binding ID for 1 DCH *1    |
|  | ATM Address              | -   | o   | -  |                                    |
|  | :                        |   |   |  |                                    |
|  | DCH ID (# n)             | -   | m   | -  |                                    |
|  | ATM Binding ID           | -   | m   | -  |                                    |
|  | ATM Address              | -   | o   | -  |                                    |
| Radio Frequency Info                   | Radio Frequency          | o   | -   | -  | Set Radio Frequency per UE         |
|  | UL Interference Level    | -   | m   | -  |                                    |
| UL Radio Resources                     | UL scrambling code       | -   | -   | -  | Set UL Scrambling Code per UE      |
|  | UL spreading code type   | -   | -   | -  |                                    |
|  | No. of UL spreading code | -   | -   | -  |                                    |
|  | UL spreading code id(s)  | -   | -   | -  |                                    |
| DL Radio Resources                     | DL spreading code type   | -   | -   | -  | Same code type for all Radio Links |

|                              |                            |   |   |   |   |
|------------------------------|----------------------------|---|---|---|---|
|                              | No. of DL spreading code   | - | - | - | Same number of codes for all Radio Links    |
|                              | No. of Radio Links         | m | - | - |   |
|                              | Radio Link ID              | m | - | - |   |
|                              | Cell ID                    | m | - | - |   |
|                              | Soft Combination Indicator | m | - | - | Indicates May, Must, Must not               |
|                              | Phase Difference           | m | - | - |   |
|                              | :                          |   |   |   |   |
|                              | Radio Link ID              | o | - | - |   |
|                              | Cell ID                    | o | - | - |   |
|                              | Soft Combination Indicator | o | - | - |   |
|                              | Phase Difference           | o | - | - |   |
| DL Radio Resources           | No. of Radio Links         | - | m | - |   |
|                              | Radio Link ID              | - | m | - |   |
|                              | Neighbor Cell Information  | - | m | - | FFS*2                                       |
|                              | No. of DL spreading code   | - | m | - |   |
|                              | DL spreading code id #1    | - | m | - |   |
|                              | :                          |   |   |   |   |
|                              | DL spreading code id #m    | - | m | - |   |
|                              | :                          |   |   |   |   |
|                              | Radio Link ID              | - | o | - |   |
|                              | Neighbor Cell Information  | - | o | - | FFS   |
|                              | No. of DL spreading code   | - | o | - |   |
|                              | DL spreading code id #1    | - | o | - |   |
|                              | :                          |   |   |   |   |
|                              | DL spreading code id #m    | - | o | - |   |
| Execution Time               | Execution Time             | - | - | - |   |
| Offset Values                | Slot offset                | - | - | - |   |
|                              | Frame offset               | - | - | - |   |
| Power Control Info           | Initial DL Power           | - | - | - | For Initial DL Power Setting                |
|                              | DL Power Range             | - | - | - | For Correcting DL Power Drifting during DHO |
| Outerloop Power Control Info | Target UL Eb/lo            | - | - | - | For L1 Power Control                        |
| Cause                        | Cause                      | - | - | m |   |

\*1,\*2: Same as the previous.

### Handover Radio Link Deletion (Inter-NodeB)

| Parameter Category                     | Iub Parameters           | Iub Message                               |   | Note                               |
|--|--------------------------|---|---|------------------------------------|
|  |                          | RA<br>DIO<br>LIN<br>K<br>DEL<br>ETI<br>ON | RA<br>DIO<br>LIN<br>K<br>DEL<br>ETI<br>ON<br>RES<br>PO<br>NSE |                                    |
| Transport CH Info                      | No. of DCHs              | -   | -   |                                    |
|  | DCH ID (# 1)             | -   | -   | DCH ID or each DCH                 |
|  | TFS (for DCH ID# 1)      | -   | -   | Set TFS when it is required        |
|  | :                        |   |   |                                    |
|  | DCH ID (# n)             | -   | -   |                                    |
|  | TFS (for DCH ID# n)      | -   | -   |                                    |
|  | TFCS (for DCHs)          | -   | -   | Set TFCS per UE                    |
| Transport Layer Addressing Information | No. of DCHs              | -   | -   |                                    |
|  | DCH ID (# 1)             | -   | -   |                                    |
|  | ATM Binding ID           | -   | -   | (TTC) 1 Binding ID for 1 DCH *1    |
|  | ATM Address              | -   | -   |                                    |
|  | :                        |   |   |                                    |
|  | DCH ID (# n)             | -   | -   |                                    |
|  | ATM Binding ID           | -   | -   |                                    |
|  | ATM Address              | -   | -   |                                    |
| Radio Frequency Info                   | Radio Frequency          | -   | -   | Set Radio Frequency per UE         |
|  | UL Interference Level    | -   | -   |                                    |
| UL Radio Resources                     | UL scrambling code       | -   | -   | Set UL Scrambling Code per UE      |
|  | UL spreading code type   | -   | -   |                                    |
|  | No. of UL spreading code | -   | -   |                                    |
|  | UL spreading code id(s)  | -   | -   |                                    |
| DL Radio Resources                     | DL spreading code type   | -   | -   | Same code type for all Radio Links |

|                              |                            |   |   |   |
|------------------------------|----------------------------|---|---|---|
|                              | No. of DL spreading code   | - | - | Same number of codes for all Radio Links    |
|                              | No. of Radio Links         | m | - |   |
|                              | Radio Link ID              | m | - |   |
|                              | Cell ID                    | - | - |   |
|                              | Soft Combination Indicator | - | - | Indicates May, Must, Must not               |
|                              | Phase Difference           | - | - |   |
|                              | :                          |   |   |   |
|                              | Radio Link ID              | o | - |   |
|                              | Cell ID                    | - | - |   |
|                              | Soft Combination Indicator | - | - |   |
|                              | Phase Difference           | - | - |   |
| DL Radio Resources           | No. of Radio Links         | - | - |   |
|                              | Radio Link ID              | - | - |   |
|                              | Neighbor Cell Information  | - | - | <b>FFS*2</b>                                |
|                              | No. of DL spreading code   | - | - |   |
|                              | DL spreading code id #1    | - | - |   |
|                              | :                          |   |   |   |
|                              | DL spreading code id #m    | - | - |   |
|                              | :                          |   |   |   |
|                              | Radio Link ID              | - | - |   |
|                              | Neighbor Cell Information  | - | - | FFS   |
|                              | No. of DL spreading code   | - | - |   |
|                              | DL spreading code id #1    | - | - |   |
|                              | :                          |   |   |   |
|                              | DL spreading code id #m    | - | - |   |
| Execution Time               | Execution Time             | - | - |   |
| Offset Values                | Slot offset                | - | - |   |
|                              | Frame offset               | - | - |   |
| Power Control Info           | Initial DL Power           | - | - | For Initial DL Power Setting                |
|                              | DL Power Range             | - | - | For Correcting DL Power Drifting during DHO |
| Outerloop Power Control Info | Target UL Eb/lo            | - | - | For L1 Power Control                        |

\*1,\*2: Same as the previous.

### Handover Radio Link Deletion (Intra-NodeB)

| Parameter Category                     | Iub Parameters           | Iub Message                               |   | Note                               |
|--|--------------------------|---|---|------------------------------------|
|  |                          |   |   |                                    |
|  |                          | RA<br>DIO<br>LIN<br>K<br>DEL<br>ETI<br>ON | RA<br>DIO<br>LIN<br>K<br>DEL<br>ETI<br>ON<br>RES<br>PO<br>NSE |                                    |
| Transport CH Info                      | No. of DCHs              | -   | -   |                                    |
|  | DCH ID (# 1)             | -   | -   | DCH ID or each DCH                 |
|  | TFS (for DCH ID# 1)      | -   | -   | Set TFS when it is required        |
|  | :                        |   |   |                                    |
|  | DCH ID (# n)             | -   | -   |                                    |
|  | TFS (for DCH ID# n)      | -   | -   |                                    |
|  | TFCS (for DCHs)          | -   | -   | Set TFCS per UE                    |
| Transport Layer Addressing Information | No. of DCHs              | -   | -   |                                    |
|  | DCH ID (# 1)             | -   | -   |                                    |
|  | ATM Binding ID           | -   | -   | (TTC) 1 Binding ID for 1 DCH *1    |
|  | ATM Address              | -   | -   |                                    |
|  | :                        |   |   |                                    |
|  | DCH ID (# n)             | -   | -   |                                    |
|  | ATM Binding ID           | -   | -   |                                    |
|  | ATM Address              | -   | -   |                                    |
| Radio Frequency Info                   | Radio Frequency          | -   | -   | Set Radio Frequency per UE         |
|  | UL Interference Level    | -   | -   |                                    |
| UL Radio Resources                     | UL scrambling code       | -   | -   | Set UL Scrambling Code per UE      |
|  | UL spreading code type   | -   | -   |                                    |
|  | No. of UL spreading code | -   | -   |                                    |
|  | UL spreading code id(s)  | -   | -   |                                    |
| DL Radio Resources                     | DL spreading code type   | -   | -   | Same code type for all Radio Links |

|                              |                            |   |   |   |
|------------------------------|----------------------------|---|---|---|
|                              | No. of DL spreading code   | - | - | Same number of codes for all Radio Links    |
|                              | No. of Radio Links         | m | - |   |
|                              | Radio Link ID              | m | - |   |
|                              | Cell ID                    | - | - |   |
|                              | Soft Combination Indicator | - | - | Indicates May, Must, Must not               |
|                              | Phase Difference           | - | - |   |
|                              | :                          |   |   |   |
|                              | Radio Link ID              | o | - |   |
|                              | Cell ID                    | - | - |   |
|                              | Soft Combination Indicator | - | - |   |
|                              | Phase Difference           | - | - |   |
| DL Radio Resources           | No. of Radio Links         | - | - |   |
|                              | Radio Link ID              | - | - |   |
|                              | Neighbor Cell Information  | - | - | <b>FFS*2</b>                                |
|                              | No. of DL spreading code   | - | - |   |
|                              | DL spreading code id #1    | - | - |   |
|                              | :                          |   |   |   |
|                              | DL spreading code id #m    | - | - |   |
|                              | :                          |   |   |   |
|                              | Radio Link ID              | - | - |   |
|                              | Neighbor Cell Information  | - | - | FFS   |
|                              | No. of DL spreading code   | - | - |   |
|                              | DL spreading code id #1    | - | - |   |
|                              | :                          |   |   |   |
|                              | DL spreading code id #m    | - | - |   |
| Execution Time               | Execution Time             | - | - |   |
| Offset Values                | Slot offset                | - | - |   |
|                              | Frame offset               | - | - |   |
| Power Control Info           | Initial DL Power           | - | - | For Initial DL Power Setting                |
|                              | DL Power Range             | - | - | For Correcting DL Power Drifting during DHO |
| Outerloop Power Control Info | Target UL Eb/lo            | - | - | For L1 Power Control                        |

\*1,\*2: Same as the previous.



## Power Control

| Parameter Category | lub Parameters   | lub Message         | Note  |
|--------------------|------------------|---------------------|---|
|                    |                  | POWR<br>CONTRO<br>L |   |
| Power Control Info | Initial DL Power | -                   | For Initial DL Power Setting                |
|                    | DL Power Range   | o                   | For Correcting DL Power Drifting during DHO |



### Outer-loop Power Control

| Parameter Category           | Iub Parameters  | Iub Message                           | Note                 |
|------------------------------|-----------------|---------------------------------------|----------------------|
|                              |                 | OUTER-<br>LOOP<br>POWR<br>CONTRO<br>L |                      |
| Outerloop Power Control Info | Target UL Eb/lo | o                                     | For L1 Power Control |

---