

CR-Form-v4

## CHANGE REQUEST

⌘ **TS 25.212 CR 111** ⌘ ev **-** ⌘ Current version: **3.5.0** ⌘

For **HELP** on using this form, see bottom of this page or look at the pop-up text over the ⌘ symbols.

**Proposed change affects:** ⌘ (U)SIM  ME/UE  Radio Access Network  Core Network

<b>Title:</b>	⌘ Correction for downlink rate matching for the DSCH		
<b>Source:</b>	⌘ Nortel Networks		
<b>Work item code:</b>	⌘	<b>Date:</b>	⌘ 05-15-2001
<b>Category:</b>	⌘ <b>F</b>	<b>Release:</b>	⌘ R99
	Use <u>one</u> of the following categories: <b>F</b> (correction) <b>A</b> (corresponds to a correction in an earlier release) <b>B</b> (addition of feature), <b>C</b> (functional modification of feature) <b>D</b> (editorial modification) Detailed explanations of the above categories can be found in 3GPP <a href="#">TR 21.900</a> .		Use <u>one</u> of the following releases: <b>2</b> (GSM Phase 2) <b>R96</b> (Release 1996) <b>R97</b> (Release 1997) <b>R98</b> (Release 1998) <b>R99</b> (Release 1999) <b>REL-4</b> (Release 4) <b>REL-5</b> (Release 5)

<b>Reason for change:</b>	⌘ Rate matching algorithm does not work for DSCH		
<b>Summary of change:</b>	⌘ Change section on calculations of the amount of rate matching to perform: for each possible number of bits available for the DSCH CCTrCh (called Ndata,*), take into account only the Transport Formats and Transport Format Combinations which apply to this Ndata,*.		
<b>Consequences if not approved:</b>	⌘ Inconsistent number of bits is output from the rate matching algorithm for the DSCH CCTrCh.		

<b>Clauses affected:</b>	⌘ 4.2.7		
<b>Other specs affected:</b>	<input type="checkbox"/> Other core specifications <input type="checkbox"/> Test specifications <input type="checkbox"/> O&M Specifications	⌘	
<b>Other comments:</b>	⌘		

### How to create CRs using this form:

Comprehensive information and tips about how to create CRs can be found at: [http://www.3gpp.org/3G\\_Specs/CRs.htm](http://www.3gpp.org/3G_Specs/CRs.htm). Below is a brief summary:

- 1) Fill out the above form. The symbols above marked ⌘ contain pop-up help information about the field that they are closest to.
- 2) Obtain the latest version for the release of the specification to which the change is proposed. Use the MS Word "revision marks" feature (also known as "track changes") when making the changes. All 3GPP specifications can be downloaded from the 3GPP server under <ftp://ftp.3gpp.org/specs/> For the latest version, look for the directory name with the latest date e.g. 2001-03 contains the specifications resulting from the March 2001 TSG meetings.
- 3) With "track changes" disabled, paste the entire CR form (use CTRL-A to select it) into the specification just in front of the clause containing the first piece of changed text. Delete those parts of the specification which are not relevant to the change request.

## 4.2.7 Rate matching

Rate matching means that bits on a transport channel are repeated or punctured. Higher layers assign a rate-matching attribute for each transport channel. This attribute is semi-static and can only be changed through higher layer signalling. The rate-matching attribute is used when the number of bits to be repeated or punctured is calculated.

The number of bits on a transport channel can vary between different transmission time intervals. In the downlink the transmission is interrupted if the number of bits is lower than maximum. When the number of bits between different transmission time intervals in uplink is changed, bits are repeated or punctured to ensure that the total bit rate after TrCH multiplexing is identical to the total channel bit rate of the allocated dedicated physical channels.

If no bits are input to the rate matching for all TrCHs within a CCTrCH, the rate matching shall output no bits for all TrCHs within the CCTrCH and no uplink DPDCH will be selected in the case of uplink rate matching.

### Notation used in subclause 4.2.7 and subclauses:

$N_{ij}$ : For uplink: Number of bits in a radio frame before rate matching on TrCH  $i$  with transport format combination  $j$ .

For downlink: An intermediate calculation variable (not an integer but a multiple of 1/8).

$N_{i,l}^{TTI}$ : Number of bits in a transmission time interval before rate matching on TrCH  $i$  with transport format  $l$ .  
Used in downlink only.

$\Delta N_{i,j}$ : For uplink: If positive - number of bits that should be repeated in each radio frame on TrCH  $i$  with transport format combination  $j$ .

If negative - number of bits that should be punctured in each radio frame on TrCH  $i$  with transport format combination  $j$ .

For downlink: An intermediate calculation variable (not an integer but a multiple of 1/8).

$\Delta N_{i,l}^{TTI}$ : If positive - number of bits to be repeated in each transmission time interval on TrCH  $i$  with transport format  $l$ .

If negative - number of bits to be punctured in each transmission time interval on TrCH  $i$  with transport format  $l$ .

Used in downlink only.

$Np_{i,l}^{TTI,m}$ ,  $m=0$  to  $(F_{max}/F_i) - 1$ : Positive or null: number of bits to be removed in TTI number  $m$  within the largest TTI, to create the required gaps in the compressed radio frames of this TTI, in case of compressed mode by puncturing, for TrCH  $i$  with transport format  $l$ . In case of fixed positions and compressed mode by puncturing, this value is noted  $Np_{i,max}^{TTI,m}$  since it is calculated for all TrCH with their maximum number of bits; thus it is the same for all TFCs

Used in downlink only.

$Np_{i,l}^n$ ,  $n=0$  to  $F_{max}-1$ : Positive or null: number of bits, in radio frame number  $n$  within the largest TTI, corresponding to the gap for compressed mode in this radio frame, for TrCH  $i$  with transport format  $l$ . The value will be null for the radio frames not overlapping with a transmission gap. In case of fixed positions and compressed mode by puncturing, this value is noted  $Np_{i,max}^n$  since it is calculated for all TrCHs with their maximum number of bits; thus it is the same for all TFCs

Used in downlink only.

$N_{TGL}[k]$ ,  $k=0$  to  $F_{max}-1$ : Positive or null: number of bits in each radio frame corresponding to the gap for compressed mode for the CCTrCH.

$RM_i$ : Semi-static rate matching attribute for transport channel  $i$ .  $RM_i$  is provided by higher layers or takes a value as indicated in section 4.2.13.

$PL$ : Puncturing limit for uplink. This value limits the amount of puncturing that can be applied in order to avoid multicoding or to enable the use of a higher spreading factor. Signalled from higher layers. The allowed puncturing in % is actually equal to  $(1-PL)*100$ .

$N_{data,j}$ : Total number of bits that are available for the CCTrCH in a radio frame with transport format combination  $j$ .

$I$ : Number of TrCHs in the CCTrCH.

$Z_{i,j}$ : Intermediate calculation variable.

$F_i$ : Number of radio frames in the transmission time interval of TrCH  $i$ .

$F_{max}$  Maximum number of radio frames in a transmission time interval used in the CCTrCH :

$$F_{max} = \max_{1 \leq i \leq I} F_i$$

$n_i$ : Radio frame number in the transmission time interval of TrCH  $i$  ( $0 \leq n_i < F_i$ ).

$q$ : Average puncturing or repetition distance (normalised to only show the remaining rate matching on top of an integer number of repetitions). Used in uplink only.

$P1_F(n_i)$ : The column permutation function of the 1<sup>st</sup> interleaver,  $P1_F(x)$  is the original position of column with number  $x$  after permutation.  $P1$  is defined on table 4 of section 4.2.5.2 (note that the  $P1_F$  is self-inverse). Used for rate matching in uplink only.

$S[n]$ : The shift of the puncturing or repetition pattern for radio frame  $n_i$  when  $n = P1_{F_i}(n_i)$ . Used in uplink only.

$TF_i(j)$ : Transport format of TrCH  $i$  for the transport format combination  $j$ .

$TFS(i)$  The set of transport format indexes  $I$  for TrCH  $i$ .

$TFCS$  The set of transport format combination indexes  $j$ .

$e_{ini}$  Initial value of variable  $e$  in the rate matching pattern determination algorithm of subclause 4.2.7.5.

$e_{plus}$  Increment of variable  $e$  in the rate matching pattern determination algorithm of subclause 4.2.7.5.

$e_{minus}$  Decrement of variable  $e$  in the rate matching pattern determination algorithm of subclause 4.2.7.5.

$b$ : Indicates systematic and parity bits

$b=1$ : Systematic bit.  $x_k$  in subclause 4.2.3.2.1.

$b=2$ : 1<sup>st</sup> parity bit (from the upper Turbo constituent encoder).  $z_k$  in subclause 4.2.3.2.1.

$b=3$ : 2<sup>nd</sup> parity bit (from the lower Turbo constituent encoder).  $z'_k$  in subclause 4.2.3.2.1.

The \* (star) notation is used to replace an index  $x$  when the indexed variable  $X_x$  does not depend on the index  $x$ . In the left wing of an assignment the meaning is that " $X_* = Y$ " is equivalent to "for all  $x$  do  $X_x = Y$ ". In the right wing of an assignment, the meaning is that " $Y = X_*$ " is equivalent to "take any  $x$  and do  $Y = X_x$ ".

The following relations, defined for all TFC  $j$ , are used when calculating the rate matching parameters:

$$Z_{0,j} = 0$$

$$Z_{i,j} = \left[ \frac{\left( \sum_{m=1}^i RM_m \times N_{m,j} \right) \times N_{data,j}}{\sum_{m=1}^I RM_m \times N_{m,j}} \right] \text{ for all } i = 1 \dots I \quad (1)$$

$$\Delta N_{i,j} = Z_{i,j} - Z_{i-1,j} - N_{i,j} \text{ for all } i = 1 \dots I$$

#### 4.2.7.1 Determination of rate matching parameters in uplink

##### 4.2.7.1.1 Determination of SF and number of PhCHs needed

In uplink, puncturing can be applied to match the CCTrCH bit rate to the PhCH bit rate. The bit rate of the PhCH(s) is limited by the UE capability and restrictions imposed by UTRAN, through limitations on the PhCH spreading factor. The maximum amount of puncturing that can be applied is 1-PL, PL is signalled from higher layers. The number of available bits in the radio frames of one PhCH for all possible spreading factors is given in [2]. Denote these values by  $N_{256}$ ,  $N_{128}$ ,  $N_{64}$ ,  $N_{32}$ ,  $N_{16}$ ,  $N_8$ , and  $N_4$ , where the index refers to the spreading factor. The possible number of bits available to the CCTrCH on all PhCHs,  $N_{data}$ , then are  $\{ N_{256}, N_{128}, N_{64}, N_{32}, N_{16}, N_8, N_4, 2 \times N_4, 3 \times N_4, 4 \times N_4, 5 \times N_4, 6 \times N_4 \}$ .

For a RACH CCTrCH SET0 represents the set of  $N_{data}$  values allowed by the UTRAN, as set by the minimum SF provided by higher layers. SET0 may be a sub-set of  $\{ N_{256}, N_{128}, N_{64}, N_{32} \}$ . SET0 does not take into account the UE's capability.

For other CCTrCHs, SET0 denotes the set of  $N_{data}$  values allowed by the UTRAN and supported by the UE, as part of the UE's capability. SET0 can be a subset of  $\{ N_{256}, N_{128}, N_{64}, N_{32}, N_{16}, N_8, N_4, 2 \times N_4, 3 \times N_4, 4 \times N_4, 5 \times N_4, 6 \times N_4 \}$ .  $N_{data,j}$  for the transport format combination  $j$  is determined by executing the following algorithm:

$$\text{SET1} = \{ N_{data} \text{ in SET0 such that } \left( \min_{1 \leq y \leq I} \{ RM_y \} \right) \times N_{data} - \sum_{x=1}^I RM_x \times N_{x,j} \text{ is non negative} \}$$

If SET1 is not empty and the smallest element of SET1 requires just one PhCH then

$$N_{data,j} = \min \text{ SET1}$$

else

$$\text{SET2} = \{ N_{data} \text{ in SET0 such that } \left( \min_{1 \leq y \leq I} \{ RM_y \} \right) \times N_{data} - PL \times \sum_{x=1}^I RM_x \times N_{x,j} \text{ is non negative} \}$$

Sort SET2 in ascending order

$$N_{data} = \min \text{ SET2}$$

While  $N_{data}$  is not the max of SET2 and the follower of  $N_{data}$  requires no additional PhCH do

$$N_{data} = \text{follower of } N_{data} \text{ in SET2}$$

End while

$$N_{data,j} = N_{data}$$

End if

For a RACH CCTrCH, if  $N_{data,j}$  is not part of the UE's capability then the TFC  $j$  cannot be used.

##### 4.2.7.1.2 Determination of parameters needed for calculating the rate matching pattern

The number of bits to be repeated or punctured,  $\Delta N_{i,j}$ , within one radio frame for each TrCH  $i$  is calculated with equation 1 for all possible transport format combinations  $j$  and selected every radio frame.  $N_{data,j}$  is given from subclause 4.2.7.1.1.

In a compressed radio frame,  $N_{data,j}$  is replaced by  $N_{data,j}^{cm}$  in Equation 1.  $N_{data,j}^{cm}$  is given as follows:

In a radio frame compressed by higher layer scheduling,  $N_{data,j}^{cm}$  is obtained by executing the algorithm in subclause 4.2.7.1.1 but with the number of bits in one radio frame of one PhCH reduced to  $\frac{N_{tr}}{15}$  of the value in normal mode.

$N_{tr}$  is the number of transmitted slots in a compressed radio frame and is defined by the following relation:

$$N_{tr} = \begin{cases} 15 - TGL, & \text{if } N_{first} + TGL \leq 15 \\ N_{first}, & \text{in first frame if } N_{first} + TGL > 15 \\ 30 - TGL - N_{first}, & \text{in second frame if } N_{first} + TGL > 15 \end{cases}$$

$N_{first}$  and  $TGL$  are defined in subclause 4.4.

In a radio frame compressed by spreading factor reduction,  $N_{data,j}^{cm} = 2 \times (N_{data,j} - N_{TGL})$ , where

$$N_{TGL} = \frac{15 - N_{tr}}{15} \times N_{data,j}$$

If  $\Delta N_{ij} = 0$  then the output data of the rate matching is the same as the input data and the rate matching algorithm of subclause 4.2.7.5 does not need to be executed.

If  $\Delta N_{ij} \neq 0$  the parameters listed in subclauses 4.2.7.1.2.1 and 4.2.7.1.2.2 shall be used for determining  $e_{mini}$ ,  $e_{plus}$ , and  $e_{minus}$  (regardless if the radio frame is compressed or not).

#### 4.2.7.1.2.1 Uncoded and convolutionally encoded TrCHs

$R = \Delta N_{ij} \bmod N_{ij}$  -- note: in this context  $\Delta N_{ij} \bmod N_{ij}$  is in the range of 0 to  $N_{ij}-1$  i.e.  $-1 \bmod 10 = 9$ .

if  $R \neq 0$  and  $2 \times R \leq N_{ij}$

$$\text{then } q = \lceil N_{ij} / R \rceil$$

else

$$q = \lceil N_{ij} / (R - N_{ij}) \rceil$$

endif

-- note: q is a signed quantity.

if q is even

$$\text{then } q' = q + \gcd(|q|, F_i) / F_i \text{ -- where } \gcd(|q|, F_i) \text{ means greatest common divisor of } |q| \text{ and } F_i$$

-- note that q' is not an integer, but a multiple of 1/8

else

$$q' = q$$

endif

for  $x = 0$  to  $F_i - 1$

$$S[\lfloor Lx \times q' \rfloor \bmod F_i] = (\lfloor Lx \times q' \rfloor \text{ div } F_i)$$

end for

$$\Delta N_i = \Delta N_{ij}$$

$$a = 2$$

For each radio frame, the rate-matching pattern is calculated with the algorithm in subclause 4.2.7.5, where :

$$X_i = N_{i,j}, \text{ and}$$

$$e_{ini} = (a \times S[P1_{F_i}(n_i)] \times |\Delta N_i| + 1) \bmod (a \cdot N_{ij}).$$

$$e_{plus} = a \times N_{ij}$$

$$e_{minus} = a \times |\Delta N_i|$$

puncturing for  $\Delta N < 0$ , repetition otherwise.

#### 4.2.7.1.2.2 Turbo encoded TrCHs

If repetition is to be performed on turbo encoded TrCHs, i.e.  $\Delta N_{ij} > 0$ , the parameters in subclause 4.2.7.1.2.1 are used.

If puncturing is to be performed, the parameters below shall be used. Index  $b$  is used to indicate systematic ( $b=1$ ), 1<sup>st</sup> parity ( $b=2$ ), and 2<sup>nd</sup> parity bit ( $b=3$ ).

$$a=2 \text{ when } b=2$$

$$a=1 \text{ when } b=3$$

$$\Delta N_i = \begin{cases} \lfloor \Delta N_{i,j} / 2 \rfloor, & b=2 \\ \lfloor \Delta N_{i,j} / 2 \rfloor, & b=3 \end{cases}$$

If  $\Delta N_i$  is calculated as 0 for  $b=2$  or  $b=3$ , then the following procedure and the rate matching algorithm of subclause 4.2.7.5 don't need to be performed for the corresponding parity bit stream.

$$X_i = \lfloor N_{i,j} / 3 \rfloor,$$

$$q = \lfloor X_i / |\Delta N_i| \rfloor$$

if ( $q \leq 2$ )

for  $r=0$  to  $F_i-1$

$$S[(3 \times r + b - 1) \bmod F_i] = r \bmod 2;$$

end for

else

if  $q$  is even

then  $q' = q - \gcd(q, F_i) / F_i$  -- where  $\gcd(q, F_i)$  means greatest common divisor of  $q$  and  $F_i$   
 -- note that  $q'$  is not an integer, but a multiple of  $1/8$

else  $q' = q$

endif

for  $x=0$  to  $F_i-1$

$$r = \lceil x \times q' \rceil \bmod F_i;$$

$$S[(3 \times r + b - 1) \bmod F_i] = \lceil x \times q' \rceil \text{ div } F_i;$$

endfor

endif

For each radio frame, the rate-matching pattern is calculated with the algorithm in subclause 4.2.7.5, where:

$X_i$  is as above:

$$e_{ini} = (a \times S[P1_{Fi}(n_j)] \times |\Delta N_i| + X_i) \bmod (a \times X_i), \text{ if } e_{ini} = 0 \text{ then } e_{ini} = a \times X_i$$

$$e_{plus} = a \times X_i$$

$$e_{minus} = a \times |\Delta N_i|$$

#### 4.2.7.2 Determination of rate matching parameters in downlink

For downlink channels other than DSCH,  $N_{data,j}$  does not depend on the transport format combination  $j$ .  $N_{data,*}$  is given by the channelisation code(s) assigned by higher layers. Denote the number of physical channels used for the CCTrCH by  $P$ .  $N_{data,*}$  is the number of bits available to the CCTrCH in one radio frame and defined as

$N_{data,*} = P \times 15 \times (N_{data1} + N_{data2})$ , where  $N_{data1}$  and  $N_{data2}$  are defined in [2]. Note that contrary to the uplink, the same rate matching patterns are used in TTIs containing no compressed radio frames and in TTIs containing radio frames compressed by spreading factor reduction or higher layer scheduling.

For DSCH, let also  $N_{data,*}$  be the number of bits available to the CCTrCH in one radio frame, given by the channelisation codes assigned by higher layers. Denote the number of physical channels used for the CCTrCH by  $P$ .  $N_{data,*}$  is defined as  $N_{data,*} = P \times 15 \times N_{data}$  where  $N_{data}$  is defined in [2] for the PDSCH.

For DSCH, different sets of channelisation codes may be configured by higher layers for different Transport Format Combinations, or even for the same Transport Format Combination. Therefore a DSCH CCTrCH configuration may correspond to multiple  $N_{data,*}$  values, each of which corresponding to a sub-set of the configured TFCs.

For DSCH, the calculations described in the rest of the current section are performed for each value of  $N_{data,*}$  given by the channelisation codes which have been configured by higher layers. For each value of  $N_{data,*}$ , only the TFCs and the TFs which apply to this  $N_{data,*}$  are considered.

In the following, the total amount of puncturing or repetition for the TTI is calculated.

Additional calculations for TTIs containing radio frames compressed by puncturing in case fixed positions are used, are performed to determine this total amount of rate matching needed.

For compressed mode by puncturing, in TTIs where some compressed radio frames occur, the puncturing is increased or the repetition is decreased compared to what is calculated according to the rate matching parameters provided by higher layers. This allows to cope with reduction of available data bits on the physical channel(s) if the slot format for the compressed frame(s) contains fewer data bits than for the normal frames(s), and to create room for later insertion of marked bits, noted p-bits, which will identify the positions of the gaps in the compressed radio frames.

The amount of additional puncturing corresponds to the number of bits to create the gap in the TTI for TrCH  $i$ , plus the difference between the number of data bits available in normal frames and in compressed frames, due to slot format change. In case of fixed positions, it is calculated in addition to the amount of rate matching indicated by higher layers.

It is noted  $Np_{i,max}^{TTI,m}$ .

In fixed positions case, to obtain the total rate matching  $\Delta N_{i,max}^{TTI,cm,m}$  to be performed on the TTI  $m$ ,  $Np_{i,max}^{TTI,m}$  is subtracted from  $\Delta N_{i,max}^{TTI,m}$  (calculated based on higher layers RM parameters as for normal rate matching). This allows to create room for the  $Np_{i,max}^{TTI,m}$  bits p to be inserted later. If the result is null, i.e. the amount of repetition matches exactly the amount of additional puncturing needed, then no rate matching is necessary.

In case of compressed mode by puncturing and fixed positions, for some calculations,  $N'_{data,*}$  is used for radio frames with gap instead of  $N_{data,*}$ , where  $N'_{data,*} = P \times 15 \times (N'_{data1} + N'_{data2})$ .  $N'_{data1}$  and  $N'_{data2}$  are the number of bits in the data fields of the slot format used for the current compressed mode, i.e. slot format A or B as defined in [2] corresponding to the Spreading Factor and the number of transmitted slots in use.

The number of bits corresponding to the gap for TrCH  $i$ , in each radio frame of its TTI is calculated using the number of bits to remove on all Physical Channels  $N_{TGL}[k]$ , where  $k$  is the radio frame number in the largest TTI.

For each radio frame  $k$  of the largest TTI that is overlapping with a transmission gap,  $N_{TGL}[k]$  is given by the relation:

$$N_{TGL} = \begin{cases} \frac{TGL}{15} \times N'_{data,*}, & \text{if } N_{first} + TGL \leq 15 \end{cases}$$

$$\frac{15 - N_{first}}{15} \times N'_{data,*}, \text{ in first radio frame of the gap if } N_{first} + TGL > 15$$

$$\frac{TGL - (15 - N_{first})}{15} \times N'_{data,*}, \text{ in second radio frame of the gap if } N_{first} + TGL > 15$$

$N_{first}$  and  $TGL$  are defined in subclause 4.4.

Note that  $N_{TGL}[k] = 0$  if radio frame  $k$  is not overlapping with a transmission gap.

#### 4.2.7.2.1 Determination of rate matching parameters for fixed positions of TrCHs

##### 4.2.7.2.1.1 Calculation of $\Delta N_{i,max}$ for normal mode and compressed mode by spreading factor reduction

First an intermediate calculation variable  $N_{i,*}$  is calculated for all transport channels  $i$  by the following formula:

$$N_{i,*} = \frac{1}{F_i} \times \left( \max_{l \in TFS(i)} N_{i,l}^{TTI} \right)$$

In order to compute the  $\Delta N_{i,l}^{TTI}$  parameters for all TrCH  $i$  and all TF  $l$ , we first compute an intermediate parameter  $\Delta N_{i,max}$  by the following formula, where  $\Delta N_{i,*}$  is derived from  $N_{i,*}$  by the formula given at subclause 4.2.7:

$$\Delta N_{i,max} = F_i \times \Delta N_{i,*}$$

If  $\Delta N_{i,max} = 0$  then, for TrCH  $i$ , the output data of the rate matching is the same as the input data and the rate matching algorithm of subclause 4.2.7.5 does not need to be executed. In this case we have :

$$\forall l \in TFS(i) \Delta N_{i,l}^{TTI} = 0$$

If  $\Delta N_{i,max} \neq 0$  the parameters listed in subclauses 4.2.7.2.1.3 and 4.2.7.2.1.4 shall be used for determining  $e_{in,i}$ ,  $e_{plus}$ , and  $e_{minus}$ , and  $\Delta N_{i,l}^{TTI}$ .

##### 4.2.7.2.1.2 Calculations for compressed mode by puncturing

Calculations of  $\Delta N_{i,max}^{TTI,m}$  for all TTI  $m$  within largest TTI, for all TrCH  $i$

First an intermediate calculation variable  $N_{i,*}$  is calculated for all transport channels  $i$  by the following formula:

$$N_{i,*} = \frac{1}{F_i} \times \left( \max_{l \in TFS(i)} N_{i,l}^{TTI} \right)$$

Then an intermediate calculation variable  $\Delta N_{i,*}$  is derived from  $N_{i,*}$  by the formula given at subclause 4.2.7, for all TrCH  $i$ .

In order to compute the  $\Delta N_{i,l}^{TTI,m}$  parameters for all TrCH  $i$ , all TF  $l$  and all TTI with number  $m$  in the largest TTI, we first compute an intermediate parameter  $\Delta N_{i,max}^m$  by the following formula :

$$\Delta N_{i,max}^m = F_i \times \Delta N_{i,*}$$



Calculations of  $Np_{i,max}^n$  and  $Np_{i,max}^{TTI,m}$

Let  $Np_{i,max}^n$  be the number of bits to eliminate on TrCH  $i$  to create the gap for compressed mode and to cope for the reduction of the number of available data bits in the compressed frame if the changed slot format contains fewer data bits than for normal frame, in each radio frame  $n$  of the TTI, calculated for the Transport Format Combination of TrCH  $i$ , in which the number of bits of TrCH  $i$  is at its maximum.

$Np_{i,max}^n$  is calculated for each radio frame  $n$  of the TTI in the following way.

Intermediate variables  $Z_i$  for  $i = 1$  to  $l$  are calculated using the formula (1) in 4.2.7, by replacing  $N_{data,j}$  by  $(N_{TGL}[n] + (N_{data,*} - N'_{data,*}))$ .

Then  $Np_{i,max}^n = (Z_i - Z_{i-1})$  for  $i = 1$  to  $l$

The total number of bits  $Np_{i,max}^{TTI,m}$  corresponding to the gaps for compressed mode for TrCH  $i$  in the TTI is calculated as:

$$Np_{i,max}^{TTI,m} = \sum_{n=m \times F_i}^{n=(m+1) \times F_i - 1} Np_{i,max}^n$$

The amount of rate matching  $\Delta N_{i,max}^{TTI,cm,m}$  for the highest TrCH bit rate is then computed by the following formula :

$$\Delta N_{i,max}^{TTI,cm,m} = \Delta N_{i,max}^m - Np_{i,max}^{TTI,m}$$

If  $\Delta N_{i,max}^{TTI,cm,m} = 0$ , then, for TrCH  $i$ , the output data of the rate matching is the same as the input data and the rate matching algorithm of subclause 4.2.7.5 does not need to be executed.

If  $\Delta N_{i,max}^{TTI,cm,m} \neq 0$ , then, for TrCH  $i$ , the rate matching algorithm of subclause 4.2.7.5 needs to be executed, and the parameters listed in subclauses 4.2.7.2.1.3 and 4.2.7.2.1.4 shall be used for determining  $e_{ini}$ ,  $e_{plus}$ , and  $e_{minus}$ , and  $\Delta N_{i,l}^{TTI,m}$ .

#### 4.2.7.2.1.3 Determination of rate matching parameters for uncoded and convolutionally encoded TrCHs

$$\Delta N_i = \Delta N_{i,max}$$

For compressed mode by puncturing,  $\Delta N_i$  is defined as:  $\Delta N_i = \Delta N_{i,max}^{TTI,cm,m}$ , instead of the previous relation.

$$a=2$$

$$N_{max} = \max_{l \in TFS(i)} N_{il}^{TTI}$$

For each transmission time interval of TrCH  $i$  with TF  $l$ , the rate-matching pattern is calculated with the algorithm in subclause 4.2.7.5. The following parameters are used as input:

$$X_i = N_{il}^{TTI}$$

$$e_{ini} = 1$$

$$e_{plus} = a \times N_{max}$$

$$e_{\min us} = a \times |\Delta N_i|$$

Puncturing if  $\Delta N_i < 0$ , repetition otherwise. The values of  $\Delta N_{i,l}^{TTI}$  may be computed by counting repetitions or puncturing when the algorithm of subclause 4.2.7.5 is run. The resulting values of  $\Delta N_{i,l}^{TTI}$  can be represented with following expression.

$$\Delta N_{i,l}^{TTI} = \left\lceil \frac{|\Delta N_i| \times X_i}{N_{max}} \right\rceil \times \text{sgn}(\Delta N_i)$$

For compressed mode by puncturing, the above formula produces  $\Delta N_{i,l}^{TTI,m}$  instead of  $\Delta N_{i,l}^{TTI}$ .

#### 4.2.7.2.1.4 Determination of rate matching parameters for Turbo encoded TrCHs

If repetition is to be performed on turbo encoded TrCHs, i.e.  $\Delta N_{i,max} > 0$ , the parameters in subclause 4.2.7.2.1.3 are used.

If puncturing is to be performed, the parameters below shall be used. Index  $b$  is used to indicate systematic ( $b=1$ ), 1<sup>st</sup> parity ( $b=2$ ), and 2<sup>nd</sup> parity bit ( $b=3$ ).

$$a=2 \text{ when } b=2$$

$$a=1 \text{ when } b=3$$

The bits indicated by  $b=1$  shall not be punctured.

$$\Delta N_i^b = \begin{cases} \left\lfloor \Delta N_{i,max} / 2 \right\rfloor, & \text{for } b=2 \\ \left\lceil \Delta N_{i,max} / 2 \right\rceil, & \text{for } b=3 \end{cases}$$

In Compressed Mode by puncturing, the following relations are used instead of the previous ones:

$$\Delta N_i^b = \left\lfloor \Delta N_{i,max}^{TTI,cm,m} / 2 \right\rfloor, \text{ for } b=2$$

$$\Delta N_{i,l}^b = \left\lceil \Delta N_{i,max}^{TTI,cm,m} / 2 \right\rceil, \text{ for } b=3$$

$$N_{max} = \max_{l \in TFS(i)} (N_{il}^{TTI} / 3)$$

For each transmission time interval of TrCH  $i$  with TF  $l$ , the rate-matching pattern is calculated with the algorithm in subclause 4.2.7.5. The following parameters are used as input:

$$X_i = N_{il}^{TTI} / 3$$

$$e_{ini} = N_{max}$$

$$e_{plus} = a \times N_{max}$$

$$e_{minus} = a \times |\Delta N_i^b|$$

The values of  $\Delta N_{i,l}^{TTI}$  may be computed by counting puncturing when the algorithm of subclause 4.2.7.5 is run. The resulting values of  $\Delta N_{i,l}^{TTI}$  can be represented with following expression.

$$\Delta N_{i,l}^{TTI} = - \left[ \frac{|\Delta N_i^2| \times X_i}{N_{max}} + 0.5 \right] - \left[ \frac{|\Delta N_i^3| \times X_i}{N_{max}} \right]$$

In the above equation, the first term of the right hand side represents the amount of puncturing for  $b=2$  and the second term represents the amount of puncturing for  $b=3$ .

For compressed mode by puncturing, the above formula produces  $\Delta N_{i,l}^{TTI,m}$  instead of  $\Delta N_{i,l}^{TTI}$ .

#### 4.2.7.2.2 Determination of rate matching parameters for flexible positions of TrCHs

##### 4.2.7.2.2.1 Calculations for normal mode, compressed mode by higher layer scheduling, and compressed mode by spreading factor reduction

First an intermediate calculation variable  $N_{ij}$  is calculated for all transport channels  $i$  and all transport format combinations  $j$  by the following formula:

$$N_{i,j} = \frac{1}{F_i} \times N_{i,TF_i(j)}^{TTI}$$

Then rate matching ratios  $RF_i$  are calculated for each the transport channel  $i$  in order to minimise the number of DTX bits when the bit rate of the CCTrCH is maximum. The  $RF_i$  ratios are defined by the following formula:

$$RF_i = \frac{N_{data,*}}{\max_{j \in TFCS} \sum_{l=1}^{i=l} (RM_l \times N_{i,j})} \times RM_i$$

The computation of  $\Delta N_{i,l}^{TTI}$  parameters is then performed in two phases. In a first phase, tentative temporary values of  $\Delta N_{i,l}^{TTI}$  are computed, and in the second phase they are checked and corrected. The first phase, by use of the  $RF_i$  ratios, ensures that the number of DTX indication bits inserted is minimum when the CCTrCH bit rate is maximum, but it does not ensure that the maximum CCTrCH bit rate is not greater than  $N_{data,*}$  per 10ms. The latter condition is ensured through the checking and possible corrections carried out in the second phase.

At the end of the second phase, the latest value of  $\Delta N_{i,l}^{TTI}$  is the definitive value.

The first phase defines the tentative temporary  $\Delta N_{i,l}^{TTI}$  for all transport channel  $i$  and any of its transport format  $l$  by use of the following formula:

$$\Delta N_{i,l}^{TTI} = F_i \times \left[ \frac{RF_i \times N_{i,l}^{TTI}}{F_i} \right] - N_{i,l}^{TTI} = F_i \times \left[ \frac{N_{data,*} \times RM_i \times N_{i,l}^{TTI}}{F_i \times \max_{j \in TFCS} \sum_{l=1}^i (RM_l \times N_{i,j})} \right] - N_{i,l}^{TTI}$$

The second phase is defined by the following algorithm:

for all  $j$  in  $TFCS$  in ascending order of TFCI do -- for all TFC

$$D = \sum_{i=1}^{i=l} \frac{N_{i,TF_i(j)}^{TTI} + \Delta N_{i,TF_i(j)}^{TTI}}{F_i} \quad \text{-- CCTrCH bit rate (bits per 10ms) for TFC } j$$

if  $D > N_{data,*}$  then

for  $i = 1$  to  $l$  do -- for all TrCH

$\Delta N = F_i \times \Delta N_{i,j}$  --  $\Delta N_{i,j}$  is derived from  $N_{i,j}$  by the formula given at subclause 4.2.7.

if  $\Delta N_{i,TF_i(j)}^{TTI} > \Delta N$  then

$$\Delta N_{i,TF_i(j)}^{TTI} = \Delta N$$

end-if

end-for

end-if

end-for

If  $\Delta N_{i,l}^{TTI} = 0$  then, for TrCH  $i$  at TF  $l$ , the output data of the rate matching is the same as the input data and the rate matching algorithm of subclause 4.2.7.5 does not need to be executed.

If  $\Delta N_{i,l}^{TTI} \neq 0$  the parameters listed in subclauses 4.2.7.2.2.2 and 4.2.7.2.2.3 shall be used for determining  $e_{ini}$ ,  $e_{plus}$ , and  $e_{minus}$ .

4.2.7.2.2.2 Determination of rate matching parameters for uncoded and convolutionally encoded TrCHs

$$\Delta N_i = \Delta N_{il}^{TTI}$$

$$a=2$$

For each transmission time interval of TrCH  $i$  with TF  $l$ , the rate-matching pattern is calculated with the algorithm in subclause 4.2.7.5. The following parameters are used as input:

$$X_i = N_{il}^{TTI}$$

$$e_{ini} = 1$$

$$e_{plus} = a \times N_{il}^{TTI}$$

$$e_{minus} = a \times |\Delta N_i|$$

puncturing for  $\Delta N_i < 0$ , repetition otherwise.

4.2.7.2.2.3 Determination of rate matching parameters for Turbo encoded TrCHs

If repetition is to be performed on turbo encoded TrCHs, i.e.  $\Delta N_{il}^{TTI} > 0$ , the parameters in subclause 4.2.7.2.2.2 are used.

If puncturing is to be performed, the parameters below shall be used. Index  $b$  is used to indicate systematic ( $b=1$ ), 1<sup>st</sup> parity ( $b=2$ ), and 2<sup>nd</sup> parity bit ( $b=3$ ).

$$a=2 \text{ when } b=2$$

$$a=1 \text{ when } b=3$$

The bits indicated by  $b=1$  shall not be punctured.

$$\Delta N_i = \begin{cases} \left\lfloor \frac{\Delta N_{il}^{TTI}}{2} \right\rfloor, & b=2 \\ \left\lfloor \frac{\Delta N_{il}^{TTI}}{2} \right\rfloor, & b=3 \end{cases}$$

For each transmission time interval of TrCH  $i$  with TF  $i$ , the rate-matching pattern is calculated with the algorithm in subclause 4.2.7.5. The following parameters are used as input:

$$X_i = N_{ii}^{TTI} / 3,$$

$$e_{ini} = X_i,$$

$$e_{plus} = a \times X_i$$

$$e_{minus} = a \times |\Delta N_i|$$

#### 4.2.7.3 Bit separation and collection in uplink

The systematic bits of turbo encoded TrCHs shall not be punctured, the other bits may be punctured. The systematic bits, first parity bits, and second parity bits in the bit sequence input to the rate matching block are therefore separated into three sequences.

The first sequence contains:

- All of the systematic bits that are from turbo encoded TrCHs.
- From 0 to 2 first and/or second parity bits that are from turbo encoded TrCHs. These bits come into the first sequence when the total number of bits in a block after radio frame segmentation is not a multiple of three.
- Some of the systematic, first parity and second parity bits that are for trellis termination.

The second sequence contains:

- All of the first parity bits that are from turbo encoded TrCHs, except those that go into the first sequence when the total number of bits is not a multiple of three.
- Some of the systematic, first parity and second parity bits that are for trellis termination.

The third sequence contains:

- All of the second parity bits that are from turbo encoded TrCHs, except those that go into the first sequence when the total number of bits is not a multiple of three.
- Some of the systematic, first parity and second parity bits that are for trellis termination.

The second and third sequences shall be of equal length, whereas the first sequence can contain from 0 to 2 more bits. Puncturing is applied only to the second and third sequences. The bit separation function is transparent for uncoded TrCHs, convolutionally encoded TrCHs, and for turbo encoded TrCHs with repetition. The bit separation and bit collection are illustrated in figures 5 and 6.

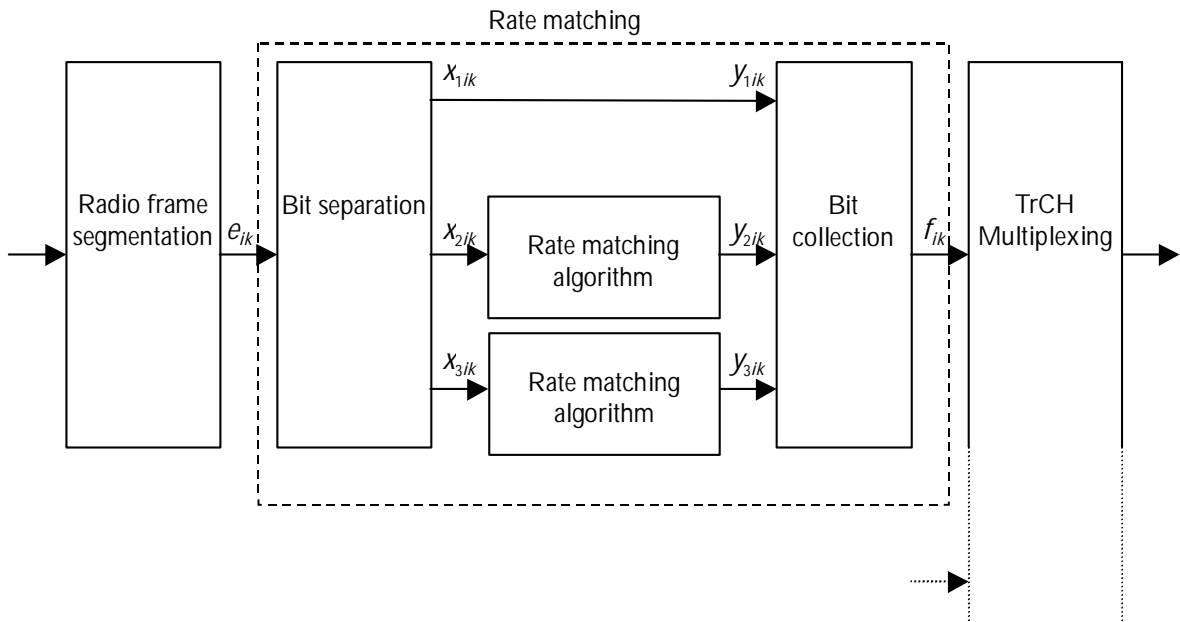

Figure 5: Puncturing of turbo encoded TrCHs in uplink

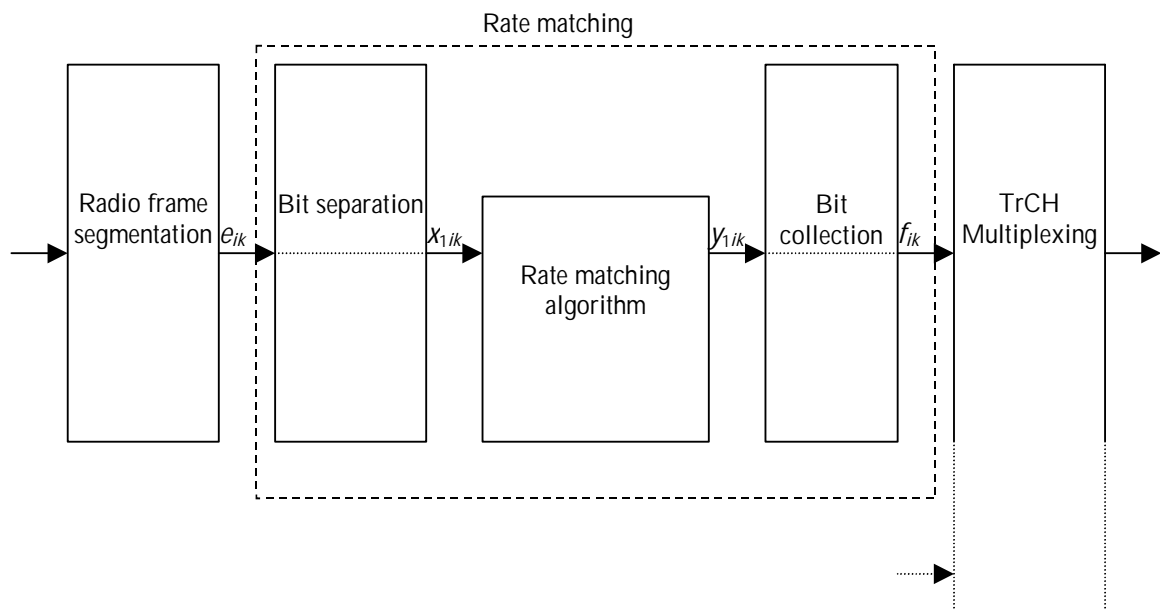

Figure 6: Rate matching for uncoded TrCHs, convolutionally encoded TrCHs, and for turbo encoded TrCHs with repetition in uplink

The bit separation is dependent on the 1<sup>st</sup> interleaving and offsets are used to define the separation for different TTIs.  $b$  indicates the three sequences defined in this section, with  $b=1$  indicating the first sequence,  $b=2$  the second one, and  $b=3$  the third one. The offsets  $\alpha_b$  for these sequences are listed in table 5.

Table 5: TTI dependent offset needed for bit separation

TTI (ms)	$\alpha_1$	$\alpha_2$	$\alpha_3$
10, 40	0	1	2
20, 80	0	2	1

The bit separation is different for different radio frames in the TTI. A second offset is therefore needed. The radio frame number for TrCH  $i$  is denoted by  $n_i$ , and the offset by  $\beta_{n_i}$ .

**Table 6: Radio frame dependent offset needed for bit separation**

TTI (ms)	$\beta_0$	$\beta_1$	$\beta_2$	$\beta_3$	$\beta_4$	$\beta_5$	$\beta_6$	$\beta_7$
10	0	NA	NA	NA	NA	NA	NA	NA
20	0	1	NA	NA	NA	NA	NA	NA
40	0	1	2	0	NA	NA	NA	NA
80	0	1	2	0	1	2	0	1

#### 4.2.7.3.1 Bit separation

The bits input to the rate matching are denoted by  $e_{i1}, e_{i2}, e_{i3}, \dots, e_{iN_i}$ , where  $i$  is the TrCH number and  $N_i$  is the number of bits input to the rate matching block. Note that the transport format combination number  $j$  for simplicity has been left out in the bit numbering, i.e.  $N_i = N_{ij}$ . The bits after separation are denoted by  $X_{bi1}, X_{bi2}, X_{bi3}, \dots, X_{biX_i}$ . For turbo encoded TrCHs with puncturing,  $b$  indicates the three sequences defined in section 4.2.7.3, with  $b=1$  indicating the first sequence, and so forth. For all other cases  $b$  is defined to be 1.  $X_i$  is the number of bits in each separated bit sequence. The relation between  $e_{ik}$  and  $X_{bik}$  is given below.

For turbo encoded TrCHs with puncturing:

$$X_{1,i,k} = e_{i,3(k-1)+1+(\alpha_1+\beta_{n_i}) \bmod 3} \quad k = 1, 2, 3, \dots, X_i \quad X_i = \lfloor N_i/3 \rfloor$$

$$X_{1,i,\lfloor N_i/3 \rfloor + k} = e_{i,3\lfloor N_i/3 \rfloor + k} \quad k = 1, \dots, N_i \bmod 3 \quad \text{Note: When } (N_i \bmod 3) = 0 \text{ this row is not needed.}$$

$$X_{2,i,k} = e_{i,3(k-1)+1+(\alpha_2+\beta_{n_i}) \bmod 3} \quad k = 1, 2, 3, \dots, X_i \quad X_i = \lfloor N_i/3 \rfloor$$

$$X_{3,i,k} = e_{i,3(k-1)+1+(\alpha_3+\beta_{n_i}) \bmod 3} \quad k = 1, 2, 3, \dots, X_i \quad X_i = \lfloor N_i/3 \rfloor$$

For uncoded TrCHs, convolutionally encoded TrCHs, and turbo encoded TrCHs with repetition:

$$X_{1,i,k} = e_{i,k} \quad k = 1, 2, 3, \dots, X_i \quad X_i = N_i$$

#### 4.2.7.3.2 Bit collection

The bits  $X_{bik}$  are input to the rate matching algorithm described in subclause 4.2.7.5. The bits output from the rate matching algorithm are denoted  $Y_{bi1}, Y_{bi2}, Y_{bi3}, \dots, Y_{biY_i}$ .

Bit collection is the inverse function of the separation. The bits after collection are denoted by  $Z_{bi1}, Z_{bi2}, Z_{bi3}, \dots, Z_{biY_i}$ .

After bit collection, the bits indicated as punctured are removed and the bits are then denoted by  $f_{i1}, f_{i2}, f_{i3}, \dots, f_{iV_i}$ , where  $i$  is the TrCH number and  $V_i = N_{ij} + \Delta N_{ij}$ . The relations between  $y_{bik}$ ,  $Z_{bik}$ , and  $f_{ik}$  are given below.

For turbo encoded TrCHs with puncturing ( $Y_i = X_i$ ):

$$Z_{i,3(k-1)+1+(\alpha_1+\beta_{n_i}) \bmod 3} = Y_{1,i,k} \quad k = 1, 2, 3, \dots, Y_i$$

$$Z_{i,3\lfloor N_i/3 \rfloor + k} = Y_{1,i,\lfloor N_i/3 \rfloor + k} \quad k = 1, \dots, N_i \bmod 3 \quad \text{Note: When } (N_i \bmod 3) = 0 \text{ this row is not needed.}$$

$$Z_{i,3(k-1)+1+(\alpha_2+\beta_{n_i}) \bmod 3} = Y_{2,i,k} \quad k = 1, 2, 3, \dots, Y_i$$

$$Z_{i,3(k-1)+1+(\alpha_3+\beta_{n_i}) \bmod 3} = Y_{3,i,k} \quad k = 1, 2, 3, \dots, Y_i$$

After the bit collection, bits  $Z_{i,k}$  with value  $\delta$ , where  $\delta \notin \{0, 1\}$ , are removed from the bit sequence. Bit  $f_{i,1}$  corresponds to the bit  $Z_{i,k}$  with smallest index  $k$  after puncturing, bit  $f_{i,2}$  corresponds to the bit  $Z_{i,k}$  with second smallest index  $k$  after puncturing, and so on.

For uncoded TrCHs, convolutionally encoded TrCHs, and turbo encoded TrCHs with repetition:

$$Z_{i,k} = Y_{1,i,k} \quad k = 1, 2, 3, \dots, Y_i$$

When repetition is used,  $f_{i,k} = Z_{i,k}$  and  $Y_i = V_i$ .

When puncturing is used,  $Y_i = X_i$  and bits  $Z_{i,k}$  with value  $\delta$ , where  $\delta \notin \{0, 1\}$ , are removed from the bit sequence. Bit  $f_{i,1}$  corresponds to the bit  $Z_{i,k}$  with smallest index  $k$  after puncturing, bit  $f_{i,2}$  corresponds to the bit  $Z_{i,k}$  with second smallest index  $k$  after puncturing, and so on.

#### 4.2.7.4 Bit separation and collection in downlink

The systematic bits of turbo encoded TrCHs shall not be punctured, the other bits may be punctured.

The systematic bits, first parity bits and second parity bits in the bit sequence input to the rate matching block are therefore separated into three sequences of equal lengths.

The first sequence contains :

- All of the systematic bits that are from turbo encoded TrCHs.
- Some of the systematic, first parity and second parity bits that are for trellis termination.

The second sequence contains:

- All of the first parity bits that are from turbo encoded TrCHs.
- Some of the systematic, first parity and second parity bits that are for trellis termination.

The third sequence contains:

- All of the second parity bits that are from turbo encoded TrCHs.
- Some of the systematic, first parity and second parity bits that are for trellis termination.

Puncturing is applied only to the second and third sequences.

The bit separation function is transparent for uncoded TrCHs, convolutionally encoded TrCHs, and for turbo encoded TrCHs with repetition. The bit separation and bit collection are illustrated in figures 7 and 8.

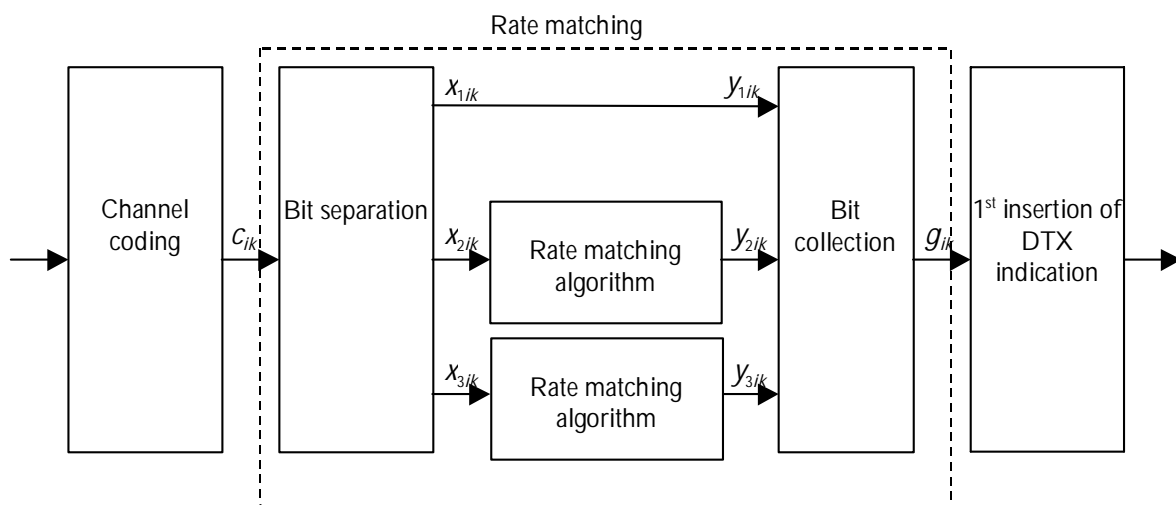
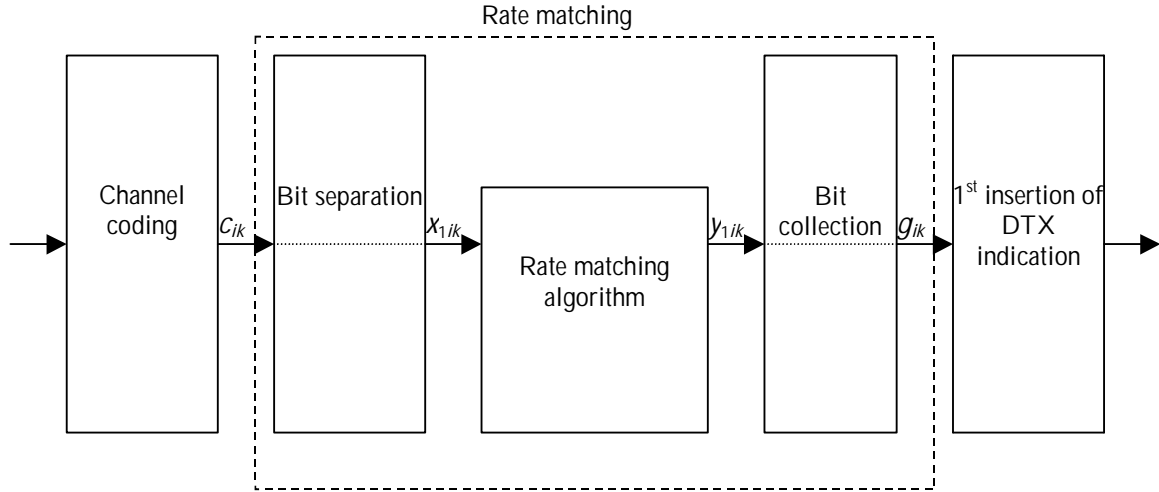

Figure 7: Puncturing of turbo encoded TrCHs in downlink





**Figure 8: Rate matching for uncoded TrCHs, convolutionally encoded TrCHs, and for turbo encoded TrCHs with repetition in downlink**

#### 4.2.7.4.1 Bit separation

The bits input to the rate matching are denoted by  $C_{i1}, C_{i2}, C_{i3}, \dots, C_{iE_i}$ , where  $i$  is the TrCH number and  $E_i$  is the number of bits input to the rate matching block. Note that  $E_i$  is a multiple of 3 for turbo encoded TrCHs and that the transport format  $T$  for simplicity has been left out in the bit numbering, i.e.  $E_i = N_{ij}^{TTI}$ . The bits after separation are denoted by  $X_{bi1}, X_{bi2}, X_{bi3}, \dots, X_{biX_i}$ . For turbo encoded TrCHs with puncturing,  $b$  indicates the three sequences defined in section 4.2.7.4, with  $b=1$  indicating the first sequence, and so forth. For all other cases  $b$  is defined to be 1.  $X_i$  is the number of bits in each separated bit sequence. The relation between  $C_{ik}$  and  $X_{bik}$  is given below.

For turbo encoded TrCHs with puncturing:

$$X_{1,i,k} = C_{i,3(k-1)+1} \quad k = 1, 2, 3, \dots, X_i \quad X_i = E_i/3$$

$$X_{2,i,k} = C_{i,3(k-1)+2} \quad k = 1, 2, 3, \dots, X_i \quad X_i = E_i/3$$

$$X_{3,i,k} = C_{i,3(k-1)+3} \quad k = 1, 2, 3, \dots, X_i \quad X_i = E_i/3$$

For uncoded TrCHs, convolutionally encoded TrCHs, and turbo encoded TrCHs with repetition:

$$X_{1,i,k} = C_{i,k} \quad k = 1, 2, 3, \dots, X_i \quad X_i = E_i$$

#### 4.2.7.4.2 Bit collection

The bits  $X_{bik}$  are input to the rate matching algorithm described in subclause 4.2.7.5. The bits output from the rate matching algorithm are denoted  $Y_{bi1}, Y_{bi2}, Y_{bi3}, \dots, Y_{biY_i}$ .

Bit collection is the inverse function of the separation. The bits after collection are denoted by  $Z_{bi1}, Z_{bi2}, Z_{bi3}, \dots, Z_{biY_i}$ . After bit collection, the bits indicated as punctured are removed and the bits are then denoted by  $g_{i1}, g_{i2}, g_{i3}, \dots, g_{iG_i}$ , where  $i$  is the TrCH number and  $G_i = N_{ij}^{TTI} + \Delta N_{ij}^{TTI}$ . The relations between  $Y_{bik}$ ,  $Z_{bik}$ , and  $g_{ik}$  are given below.

For turbo encoded TrCHs with puncturing ( $Y_i = X_i$ ):

$$Z_{i,3(k-1)+1} = Y_{1,i,k} \quad k = 1, 2, 3, \dots, Y_i$$

$$Z_{i,3(k-1)+2} = Y_{2,i,k} \quad k = 1, 2, 3, \dots, Y_i$$

$$Z_{i,3(k-1)+3} = Y_{3,i,k} \quad k = 1, 2, 3, \dots, Y_i$$

After the bit collection, bits  $Z_{i,k}$  with value  $\delta$ , where  $\delta \notin \{0, 1\}$ , are removed from the bit sequence. Bit  $g_{i,1}$  corresponds to the bit  $Z_{i,k}$  with smallest index  $k$  after puncturing, bit  $g_{i,2}$  corresponds to the bit  $Z_{i,k}$  with second smallest index  $k$  after puncturing, and so on.

For uncoded TrCHs, convolutionally encoded TrCHs, and turbo encoded TrCHs with repetition:

$$Z_{i,k} = Y_{1,i,k} \quad k = 1, 2, 3, \dots, Y_i$$

When repetition is used,  $g_{i,k} = Z_{i,k}$  and  $Y_i = G_i$ .

When puncturing is used,  $Y_i = X_i$  and bits  $Z_{i,k}$  with value  $\delta$ , where  $\delta \notin \{0, 1\}$ , are removed from the bit sequence. Bit  $g_{i,1}$  corresponds to the bit  $Z_{i,k}$  with smallest index  $k$  after puncturing, bit  $g_{i,2}$  corresponds to the bit  $Z_{i,k}$  with second smallest index  $k$  after puncturing, and so on.

#### 4.2.7.5 Rate matching pattern determination

Denote the bits before rate matching by:

$X_{i,1}, X_{i,2}, X_{i,3}, \dots, X_{i,X_i}$ , where  $i$  is the TrCH number and the sequence is defined in 4.2.7.3 for uplink or in 4.2.7.4 for downlink. Parameters  $X_i$ ,  $e_{ini}$ ,  $e_{plus}$ , and  $e_{minus}$  are given in 4.2.7.1 for uplink or in 4.2.7.2 for downlink.

The rate matching rule is as follows:

if puncturing is to be performed

$e = e_{ini}$  -- initial error between current and desired puncturing ratio

$m = 1$  -- index of current bit

do while  $m \leq X_i$

$e = e - e_{minus}$  -- update error

if  $e \leq 0$  then -- check if bit number  $m$  should be punctured

set bit  $x_{i,m}$  to  $\delta$  where  $\delta \notin \{0, 1\}$

$e = e + e_{plus}$  -- update error

end if

$m = m + 1$  -- next bit

end do

else

$e = e_{ini}$  -- initial error between current and desired puncturing ratio

$m = 1$  -- index of current bit

do while  $m \leq X_i$

$e = e - e_{minus}$  -- update error

do while  $e \leq 0$  -- check if bit number  $m$  should be repeated

repeat bit  $x_{i,m}$

$e = e + e_{plus}$  -- update error

```
end do
   $m = m + 1$       -- next bit
end do
end if
```

A repeated bit is placed directly after the original one.

# CHANGE REQUEST

⌘ **TS 25.212 CR 112** ⌘ ev **-** ⌘ Current version: **4.0.0** ⌘

For **HELP** on using this form, see bottom of this page or look at the pop-up text over the ⌘ symbols.

**Proposed change affects:** ⌘ (U)SIM  ME/UE  Radio Access Network  Core Network

<b>Title:</b>	⌘ Correction for downlink rate matching for the DSCH		
<b>Source:</b>	⌘ Nortel Networks		
<b>Work item code:</b>	⌘	<b>Date:</b>	⌘ 05-15-2001
<b>Category:</b>	⌘ <b>F</b>	<b>Release:</b>	⌘ REL-4
	<i>Use <u>one</u> of the following categories:</i> <b>F</b> (correction) <b>A</b> (corresponds to a correction in an earlier release) <b>B</b> (addition of feature), <b>C</b> (functional modification of feature) <b>D</b> (editorial modification)		<i>Use <u>one</u> of the following releases:</i> <b>2</b> (GSM Phase 2) <b>R96</b> (Release 1996) <b>R97</b> (Release 1997) <b>R98</b> (Release 1998) <b>R99</b> (Release 1999) <b>REL-4</b> (Release 4) <b>REL-5</b> (Release 5)
	Detailed explanations of the above categories can be found in 3GPP <a href="http://www.3gpp.org/ftp/Specs/3GPP/25.212-000/CR-112">TR 21.900</a> .		

<b>Reason for change:</b>	⌘ Rate matching algorithm does not work for DSCH		
<b>Summary of change:</b>	⌘ Change section on calculations of the amount of rate matching to perform: for each possible number of bits available for the DSCH CCTrCh (called Ndata,*), take into account only the Transport Formats and Transport Format Combinations which apply to this Ndata,*.		
<b>Consequences if not approved:</b>	⌘ Inconsistent number of bits is output from the rate matching algorithm for the DSCH CCTrCh.		

<b>Clauses affected:</b>	⌘ 4.2.7		
<b>Other specs affected:</b>	⌘ <input type="checkbox"/> Other core specifications <input type="checkbox"/> Test specifications <input type="checkbox"/> O&M Specifications	⌘	
<b>Other comments:</b>	⌘		

### How to create CRs using this form:

Comprehensive information and tips about how to create CRs can be found at: [http://www.3gpp.org/3G\\_Specs/CRs.htm](http://www.3gpp.org/3G_Specs/CRs.htm). Below is a brief summary:

- 1) Fill out the above form. The symbols above marked ⌘ contain pop-up help information about the field that they are closest to.
- 2) Obtain the latest version for the release of the specification to which the change is proposed. Use the MS Word "revision marks" feature (also known as "track changes") when making the changes. All 3GPP specifications can be downloaded from the 3GPP server under [ftp://ftp.3gpp.org/specs/](http://ftp.3gpp.org/specs/) For the latest version, look for the directory name with the latest date e.g. 2001-03 contains the specifications resulting from the March 2001 TSG meetings.
- 3) With "track changes" disabled, paste the entire CR form (use CTRL-A to select it) into the specification just in front of the clause containing the first piece of changed text. Delete those parts of the specification which are not relevant to the change request.

## 4.2.7 Rate matching

Rate matching means that bits on a transport channel are repeated or punctured. Higher layers assign a rate-matching attribute for each transport channel. This attribute is semi-static and can only be changed through higher layer signalling. The rate-matching attribute is used when the number of bits to be repeated or punctured is calculated.

The number of bits on a transport channel can vary between different transmission time intervals. In the downlink the transmission is interrupted if the number of bits is lower than maximum. When the number of bits between different transmission time intervals in uplink is changed, bits are repeated or punctured to ensure that the total bit rate after TrCH multiplexing is identical to the total channel bit rate of the allocated dedicated physical channels.

If no bits are input to the rate matching for all TrCHs within a CCTrCH, the rate matching shall output no bits for all TrCHs within the CCTrCH and no uplink DPDCH will be selected in the case of uplink rate matching.

### Notation used in subclause 4.2.7 and subclauses:

$N_{i,j}$ : For uplink: Number of bits in a radio frame before rate matching on TrCH  $i$  with transport format combination  $j$ .

For downlink: An intermediate calculation variable (not an integer but a multiple of 1/8).

$N_{i,l}^{TTI}$ : Number of bits in a transmission time interval before rate matching on TrCH  $i$  with transport format  $l$ .  
Used in downlink only.

$\Delta N_{i,j}$ : For uplink: If positive - number of bits that should be repeated in each radio frame on TrCH  $i$  with transport format combination  $j$ .

If negative - number of bits that should be punctured in each radio frame on TrCH  $i$  with transport format combination  $j$ .

For downlink: An intermediate calculation variable (not an integer but a multiple of 1/8).

$\Delta N_{i,l}^{TTI}$ : If positive - number of bits to be repeated in each transmission time interval on TrCH  $i$  with transport format  $l$ .

If negative - number of bits to be punctured in each transmission time interval on TrCH  $i$  with transport format  $l$ .

Used in downlink only.

$Np_{i,l}^{TTI,m}$ ,  $m=0$  to  $(F_{max}/F_i) - 1$ : Positive or null: number of bits to be removed in TTI number  $m$  within the largest TTI, to create the required gaps in the compressed radio frames of this TTI, in case of compressed mode by puncturing, for TrCH  $i$  with transport format  $l$ . In case of fixed positions and compressed mode by puncturing, this value is noted  $Np_{i,max}^{TTI,m}$  since it is calculated for all TrCH with their maximum number of bits; thus it is the same for all TFCs

Used in downlink only.

$Np_{i,l}^n$ ,  $n=0$  to  $F_{max}-1$ : Positive or null: number of bits, in radio frame number  $n$  within the largest TTI, corresponding to the gap for compressed mode in this radio frame, for TrCH  $i$  with transport format  $l$ . The value will be null for the radio frames not overlapping with a transmission gap. In case of fixed positions and compressed mode by puncturing, this value is noted  $Np_{i,max}^n$  since it is calculated for all TrCHs with their maximum number of bits; thus it is the same for all TFCs

Used in downlink only.

$N_{TGL}[k]$ ,  $k=0$  to  $F_{max}-1$ : Positive or null: number of bits in each radio frame corresponding to the gap for compressed mode for the CCTrCH.

$RM_i$ : Semi-static rate matching attribute for transport channel  $i$ .  $RM_i$  is provided by higher layers or takes a value as indicated in section 4.2.13.

$PL$ : Puncturing limit for uplink. This value limits the amount of puncturing that can be applied in order to avoid multicoding or to enable the use of a higher spreading factor. Signalled from higher layers. The allowed puncturing in % is actually equal to  $(1-PL)*100$ .

$N_{data,j}$ : Total number of bits that are available for the CCTrCH in a radio frame with transport format combination  $j$ .

$I$ : Number of TrCHs in the CCTrCH.

$Z_{i,j}$ : Intermediate calculation variable.

$F_i$ : Number of radio frames in the transmission time interval of TrCH  $i$ .

$F_{max}$ : Maximum number of radio frames in a transmission time interval used in the CCTrCH :

$$F_{max} = \max_{1 \leq i \leq I} F_i$$

$n_i$ : Radio frame number in the transmission time interval of TrCH  $i$  ( $0 \leq n_i < F_i$ ).

$q$ : Average puncturing or repetition distance (normalised to only show the remaining rate matching on top of an integer number of repetitions). Used in uplink only.

$P1_F(n_i)$ : The column permutation function of the 1<sup>st</sup> interleaver,  $P1_F(x)$  is the original position of column with number  $x$  after permutation.  $P1$  is defined on table 4 of section 4.2.5.2 (note that the  $P1_F$  is self-inverse). Used for rate matching in uplink only.

$S[n]$ : The shift of the puncturing or repetition pattern for radio frame  $n_i$  when  $n = P1_{F_i}(n_i)$ . Used in uplink only.

$TF_i(j)$ : Transport format of TrCH  $i$  for the transport format combination  $j$ .

$TFS(i)$ : The set of transport format indexes  $I$  for TrCH  $i$ .

$TFCS$ : The set of transport format combination indexes  $j$ .

$e_{ini}$ : Initial value of variable  $e$  in the rate matching pattern determination algorithm of subclause 4.2.7.5.

$e_{plus}$ : Increment of variable  $e$  in the rate matching pattern determination algorithm of subclause 4.2.7.5.

$e_{minus}$ : Decrement of variable  $e$  in the rate matching pattern determination algorithm of subclause 4.2.7.5.

$b$ : Indicates systematic and parity bits

$b=1$ : Systematic bit.  $x_k$  in subclause 4.2.3.2.1.

$b=2$ : 1<sup>st</sup> parity bit (from the upper Turbo constituent encoder).  $z_k$  in subclause 4.2.3.2.1.

$b=3$ : 2<sup>nd</sup> parity bit (from the lower Turbo constituent encoder).  $z'_k$  in subclause 4.2.3.2.1.

The \* (star) notation is used to replace an index  $x$  when the indexed variable  $X_x$  does not depend on the index  $x$ . In the left wing of an assignment the meaning is that " $X_* = Y$ " is equivalent to "for all  $x$  do  $X_x = Y$ ". In the right wing of an assignment, the meaning is that " $Y = X_*$ " is equivalent to "take any  $x$  and do  $Y = X_x$ ".

The following relations, defined for all TFC  $j$ , are used when calculating the rate matching parameters:

$$Z_{0,j} = 0$$

$$Z_{i,j} = \left[ \frac{\left( \left( \sum_{m=1}^i RM_m \times N_{m,j} \right) \times N_{data,j} \right)}{\sum_{m=1}^i RM_m \times N_{m,j}} \right] \text{ for all } i = 1 \dots I \quad (1)$$

$$\Delta N_{i,j} = Z_{i,j} - Z_{i-1,j} - N_{i,j} \text{ for all } i = 1 \dots I$$

#### 4.2.7.1 Determination of rate matching parameters in uplink

##### 4.2.7.1.1 Determination of SF and number of PhCHs needed

In uplink, puncturing can be applied to match the CCTrCH bit rate to the PhCH bit rate. The bit rate of the PhCH(s) is limited by the UE capability and restrictions imposed by UTRAN, through limitations on the PhCH spreading factor. The maximum amount of puncturing that can be applied is 1-PL, PL is signalled from higher layers. The number of available bits in the radio frames of one PhCH for all possible spreading factors is given in [2]. Denote these values by  $N_{256}$ ,  $N_{128}$ ,  $N_{64}$ ,  $N_{32}$ ,  $N_{16}$ ,  $N_8$ , and  $N_4$ , where the index refers to the spreading factor. The possible number of bits available to the CCTrCH on all PhCHs,  $N_{data}$ , then are  $\{ N_{256}, N_{128}, N_{64}, N_{32}, N_{16}, N_8, N_4, 2 \times N_4, 3 \times N_4, 4 \times N_4, 5 \times N_4, 6 \times N_4 \}$ .

For a RACH CCTrCH SET0 represents the set of  $N_{data}$  values allowed by the UTRAN, as set by the minimum SF provided by higher layers. SET0 may be a sub-set of  $\{ N_{256}, N_{128}, N_{64}, N_{32} \}$ . SET0 does not take into account the UE's capability.

For other CCTrCHs, SET0 denotes the set of  $N_{data}$  values allowed by the UTRAN and supported by the UE, as part of the UE's capability. SET0 can be a subset of  $\{ N_{256}, N_{128}, N_{64}, N_{32}, N_{16}, N_8, N_4, 2 \times N_4, 3 \times N_4, 4 \times N_4, 5 \times N_4, 6 \times N_4 \}$ .  $N_{data,j}$  for the transport format combination  $j$  is determined by executing the following algorithm:

$$\text{SET1} = \{ N_{data} \text{ in SET0 such that } \left( \min_{1 \leq y \leq I} \{ RM_y \} \right) \times N_{data} - \sum_{x=1}^I RM_x \times N_{x,j} \text{ is non negative} \}$$

If SET1 is not empty and the smallest element of SET1 requires just one PhCH then

$$N_{data,j} = \min \text{ SET1}$$

else

$$\text{SET2} = \{ N_{data} \text{ in SET0 such that } \left( \min_{1 \leq y \leq I} \{ RM_y \} \right) \times N_{data} - PL \times \sum_{x=1}^I RM_x \times N_{x,j} \text{ is non negative} \}$$

Sort SET2 in ascending order

$$N_{data} = \min \text{ SET2}$$

While  $N_{data}$  is not the max of SET2 and the follower of  $N_{data}$  requires no additional PhCH do

$$N_{data} = \text{follower of } N_{data} \text{ in SET2}$$

End while

$$N_{data,j} = N_{data}$$

End if

For a RACH CCTrCH, if  $N_{data,j}$  is not part of the UE's capability then the TFC  $j$  cannot be used.

##### 4.2.7.1.2 Determination of parameters needed for calculating the rate matching pattern

The number of bits to be repeated or punctured,  $\Delta N_{i,j}$ , within one radio frame for each TrCH  $i$  is calculated with equation 1 for all possible transport format combinations  $j$  and selected every radio frame.  $N_{data,j}$  is given from subclause 4.2.7.1.1.

In a compressed radio frame,  $N_{data,j}$  is replaced by  $N_{data,j}^{cm}$  in Equation 1.  $N_{data,j}^{cm}$  is given as follows:

In a radio frame compressed by higher layer scheduling,  $N_{data,j}^{cm}$  is obtained by executing the algorithm in subclause 4.2.7.1.1 but with the number of bits in one radio frame of one PhCH reduced to  $\frac{N_{tr}}{15}$  of the value in normal mode.

$N_{tr}$  is the number of transmitted slots in a compressed radio frame and is defined by the following relation:

$$N_{tr} = \begin{cases} 15 - TGL, & \text{if } N_{first} + TGL \leq 15 \\ N_{first}, & \text{in first frame if } N_{first} + TGL > 15 \\ 30 - TGL - N_{first}, & \text{in second frame if } N_{first} + TGL > 15 \end{cases}$$

$N_{first}$  and  $TGL$  are defined in subclause 4.4.

In a radio frame compressed by spreading factor reduction,  $N_{data,j}^{cm} = 2 \times (N_{data,j} - N_{TGL})$ , where

$$N_{TGL} = \frac{15 - N_{tr}}{15} \times N_{data,j}$$

If  $\Delta N_{ij} = 0$  then the output data of the rate matching is the same as the input data and the rate matching algorithm of subclause 4.2.7.5 does not need to be executed.

If  $\Delta N_{ij} \neq 0$  the parameters listed in subclauses 4.2.7.1.2.1 and 4.2.7.1.2.2 shall be used for determining  $e_{mini}$ ,  $e_{plus}$ , and  $e_{minus}$  (regardless if the radio frame is compressed or not).

#### 4.2.7.1.2.1 Uncoded and convolutionally encoded TrCHs

$R = \Delta N_{ij} \bmod N_{ij}$  -- note: in this context  $\Delta N_{ij} \bmod N_{ij}$  is in the range of 0 to  $N_{ij}-1$  i.e.  $-1 \bmod 10 = 9$ .

if  $R \neq 0$  and  $2 \times R \leq N_{ij}$

$$\text{then } q = \lceil N_{ij} / R \rceil$$

else

$$q = \lceil N_{ij} / (R - N_{ij}) \rceil$$

endif

-- note:  $q$  is a signed quantity.

if  $q$  is even

$$\text{then } q' = q + \gcd(|q|, F_i) / F_i \text{ -- where } \gcd(|q|, F_i) \text{ means greatest common divisor of } |q| \text{ and } F_i$$

-- note that  $q'$  is not an integer, but a multiple of  $1/8$

else

$$q' = q$$

endif

for  $x = 0$  to  $F_i - 1$

$$S[\lfloor \lfloor x \times q' \rfloor \rfloor \bmod F_i] = (\lfloor \lfloor x \times q' \rfloor \rfloor \text{ div } F_i)$$

end for

$$\Delta N_i = \Delta N_{ij}$$

$$a = 2$$



For each radio frame, the rate-matching pattern is calculated with the algorithm in subclause 4.2.7.5, where :

$$X_i = N_{i,j}, \text{ and}$$

$$e_{ini} = (a \times S[P1_{F_i}(n_i)] \times |\Delta N_i| + 1) \bmod (a \cdot N_{ij}).$$

$$e_{plus} = a \times N_{ij}$$

$$e_{minus} = a \times |\Delta N_i|$$

puncturing for  $\Delta N < 0$ , repetition otherwise.

#### 4.2.7.1.2.2 Turbo encoded TrCHs

If repetition is to be performed on turbo encoded TrCHs, i.e.  $\Delta N_{ij} > 0$ , the parameters in subclause 4.2.7.1.2.1 are used.

If puncturing is to be performed, the parameters below shall be used. Index  $b$  is used to indicate systematic ( $b=1$ ), 1<sup>st</sup> parity ( $b=2$ ), and 2<sup>nd</sup> parity bit ( $b=3$ ).

$$a=2 \text{ when } b=2$$

$$a=1 \text{ when } b=3$$

$$\Delta N_i = \begin{cases} \lfloor \Delta N_{i,j} / 2 \rfloor, & b=2 \\ \lfloor \Delta N_{i,j} / 2 \rfloor, & b=3 \end{cases}$$

If  $\Delta N_i$  is calculated as 0 for  $b=2$  or  $b=3$ , then the following procedure and the rate matching algorithm of subclause 4.2.7.5 don't need to be performed for the corresponding parity bit stream.

$$X_i = \lfloor N_{i,j} / 3 \rfloor,$$

$$q = \lfloor X_i / |\Delta N_i| \rfloor$$

if ( $q \leq 2$ )

for  $r=0$  to  $F_i-1$

$$S[(3 \times r + b - 1) \bmod F_i] = r \bmod 2;$$

end for

else

if  $q$  is even

then  $q' = q - \gcd(q, F_i) / F_i$  -- where  $\gcd(q, F_i)$  means greatest common divisor of  $q$  and  $F_i$   
-- note that  $q'$  is not an integer, but a multiple of  $1/8$

else  $q' = q$

endif

for  $x=0$  to  $F_i-1$

$$r = \lceil x \times q' \rceil \bmod F_i;$$

$$S[(3 \times r + b - 1) \bmod F_i] = \lceil x \times q' \rceil \text{ div } F_i;$$

endfor

endif

For each radio frame, the rate-matching pattern is calculated with the algorithm in subclause 4.2.7.5, where:

$X_i$  is as above:

$$e_{ini} = (a \times S[P1_{F_i}(n_i)] \times |\Delta N_i| + X_i) \bmod (a \times X_i), \text{ if } e_{ini} = 0 \text{ then } e_{ini} = a \times X_i$$

$$e_{plus} = a \times X_i$$

$$e_{minus} = a \times |\Delta N_i|$$

#### 4.2.7.2 Determination of rate matching parameters in downlink

For downlink channels other than DSCH,  $N_{data,j}$  does not depend on the transport format combination  $j$ .  $N_{data,*}$  is given by the channelisation code(s) assigned by higher layers. Denote the number of physical channels used for the CCTrCH by  $P$ .  $N_{data,*}$  is the number of bits available to the CCTrCH in one radio frame and defined as

$N_{data,*} = P \times 15 \times (N_{data1} + N_{data2})$ , where  $N_{data1}$  and  $N_{data2}$  are defined in [2]. Note that contrary to the uplink, the same rate matching patterns are used in TTIs containing no compressed radio frames and in TTIs containing radio frames compressed by spreading factor reduction or higher layer scheduling.

For DSCH, let also  $N_{data,*}$  be the number of bits available to the CCTrCH in one radio frame, given by the channelisation codes assigned by higher layers. Denote the number of physical channels used for the CCTrCH by  $P$ .  $N_{data,*}$  is defined as  $N_{data,*} = P \times 15 \times N_{data}$  where  $N_{data}$  is defined in [2] for the PDSCH.

For DSCH, different sets of channelisation codes may be configured by higher layers for different Transport Format Combinations, or even for the same Transport Format Combination. Therefore a DSCH CCTrCH configuration may correspond to multiple  $N_{data,*}$  values, each of which corresponding to a sub-set of the configured TFCs.

For DSCH, the calculations described in the rest of the current section are performed for each value of  $N_{data,*}$  given by the channelisation codes which have been configured by higher layers. For each value of  $N_{data,*}$ , only the TFCs and the TFs which apply to this  $N_{data,*}$  are considered.

In the following, the total amount of puncturing or repetition for the TTI is calculated.

Additional calculations for TTIs containing radio frames compressed by puncturing in case fixed positions are used, are performed to determine this total amount of rate matching needed.

For compressed mode by puncturing, in TTIs where some compressed radio frames occur, the puncturing is increased or the repetition is decreased compared to what is calculated according to the rate matching parameters provided by higher layers. This allows to cope with reduction of available data bits on the physical channel(s) if the slot format for the compressed frame(s) contains fewer data bits than for the normal frames(s), and to create room for later insertion of marked bits, noted p-bits, which will identify the positions of the gaps in the compressed radio frames.

The amount of additional puncturing corresponds to the number of bits to create the gap in the TTI for TrCH  $i$ , plus the difference between the number of data bits available in normal frames and in compressed frames, due to slot format change. In case of fixed positions, it is calculated in addition to the amount of rate matching indicated by higher layers.

It is noted  $Np_{i,max}^{TTI,m}$ .

In fixed positions case, to obtain the total rate matching  $\Delta N_{i,max}^{TTI,cm,m}$  to be performed on the TTI  $m$ ,  $Np_{i,max}^{TTI,m}$  is subtracted from  $\Delta N_{i,max}^{TTI,m}$  (calculated based on higher layers RM parameters as for normal rate matching). This allows to create room for the  $Np_{i,max}^{TTI,m}$  bits p to be inserted later. If the result is null, i.e. the amount of repetition matches exactly the amount of additional puncturing needed, then no rate matching is necessary.

In case of compressed mode by puncturing and fixed positions, for some calculations,  $N'_{data,*}$  is used for radio frames with gap instead of  $N_{data,*}$ , where  $N'_{data,*} = P \times 15 \times (N'_{data1} + N'_{data2})$ .  $N'_{data1}$  and  $N'_{data2}$  are the number of bits in the data fields of the slot format used for the current compressed mode, i.e. slot format A or B as defined in [2] corresponding to the Spreading Factor and the number of transmitted slots in use.

The number of bits corresponding to the gap for TrCH  $i$ , in each radio frame of its TTI is calculated using the number of bits to remove on all Physical Channels  $N_{TGL}[k]$ , where  $k$  is the radio frame number in the largest TTI.

For each radio frame  $k$  of the largest TTI that is overlapping with a transmission gap,  $N_{TGL}[k]$  is given by the relation:

$$N_{TGL} = \begin{cases} \frac{TGL}{15} \times N'_{data,*}, & \text{if } N_{first} + TGL \leq 15 \end{cases}$$

$$\frac{15 - N_{first}}{15} \times N'_{data,*}, \text{ in first radio frame of the gap if } N_{first} + TGL > 15$$

$$\frac{TGL - (15 - N_{first})}{15} \times N'_{data,*}, \text{ in second radio frame of the gap if } N_{first} + TGL > 15$$

$N_{first}$  and  $TGL$  are defined in subclause 4.4.

Note that  $N_{TGL}[k] = 0$  if radio frame  $k$  is not overlapping with a transmission gap.

#### 4.2.7.2.1 Determination of rate matching parameters for fixed positions of TrCHs

##### 4.2.7.2.1.1 Calculation of $\Delta N_{i,max}$ for normal mode and compressed mode by spreading factor reduction

First an intermediate calculation variable  $N_{i,*}$  is calculated for all transport channels  $i$  by the following formula:

$$N_{i,*} = \frac{1}{F_i} \times \left( \max_{l \in TFS(i)} N_{i,l}^{TTI} \right)$$

In order to compute the  $\Delta N_{i,l}^{TTI}$  parameters for all TrCH  $i$  and all TF  $l$ , we first compute an intermediate parameter  $\Delta N_{i,max}$  by the following formula, where  $\Delta N_{i,*}$  is derived from  $N_{i,*}$  by the formula given at subclause 4.2.7:

$$\Delta N_{i,max} = F_i \times \Delta N_{i,*}$$

If  $\Delta N_{i,max} = 0$  then, for TrCH  $i$ , the output data of the rate matching is the same as the input data and the rate matching algorithm of subclause 4.2.7.5 does not need to be executed. In this case we have :

$$\forall l \in TFS(i) \Delta N_{i,l}^{TTI} = 0$$

If  $\Delta N_{i,max} \neq 0$  the parameters listed in subclauses 4.2.7.2.1.3 and 4.2.7.2.1.4 shall be used for determining  $e_{in,i}$ ,  $e_{plus}$ , and  $e_{minus}$ , and  $\Delta N_{i,l}^{TTI}$ .

##### 4.2.7.2.1.2 Calculations for compressed mode by puncturing

Calculations of  $\Delta N_{i,max}^{TTI,m}$  for all TTI  $m$  within largest TTI, for all TrCH  $i$

First an intermediate calculation variable  $N_{i,*}$  is calculated for all transport channels  $i$  by the following formula:

$$N_{i,*} = \frac{1}{F_i} \times \left( \max_{l \in TFS(i)} N_{i,l}^{TTI} \right)$$

Then an intermediate calculation variable  $\Delta N_{i,*}$  is derived from  $N_{i,*}$  by the formula given at subclause 4.2.7, for all TrCH  $i$ .

In order to compute the  $\Delta N_{i,l}^{TTI,m}$  parameters for all TrCH  $i$ , all TF  $l$  and all TTI with number  $m$  in the largest TTI, we first compute an intermediate parameter  $\Delta N_{i,max}^m$  by the following formula :

$$\Delta N_{i,max}^m = F_i \times \Delta N_{i,*}$$

Calculations of  $Np_{i,max}^n$  and  $Np_{i,max}^{TTI,m}$

Let  $Np_{i,max}^n$  be the number of bits to eliminate on TrCH  $i$  to create the gap for compressed mode and to cope for the reduction of the number of available data bits in the compressed frame if the changed slot format contains fewer data bits than for normal frame, in each radio frame  $n$  of the TTI, calculated for the Transport Format Combination of TrCH  $i$ , in which the number of bits of TrCH  $i$  is at its maximum.

$Np_{i,max}^n$  is calculated for each radio frame  $n$  of the TTI in the following way.

Intermediate variables  $Z_i$  for  $i = 1$  to  $l$  are calculated using the formula (1) in 4.2.7, by replacing  $N_{data,j}$  by  $(N_{TGL}[n] + (N_{data,*} - N'_{data,*}))$ .

Then  $Np_{i,max}^n = (Z_i - Z_{i-1})$  for  $i = 1$  to  $l$

The total number of bits  $Np_{i,max}^{TTI,m}$  corresponding to the gaps for compressed mode for TrCH  $i$  in the TTI is calculated as:

$$Np_{i,max}^{TTI,m} = \sum_{n=m \times F_i}^{n=(m+1) \times F_i - 1} Np_{i,max}^n$$

The amount of rate matching  $\Delta N_{i,max}^{TTI,cm,m}$  for the highest TrCH bit rate is then computed by the following formula :

$$\Delta N_{i,max}^{TTI,cm,m} = \Delta N_{i,max}^m - Np_{i,max}^{TTI,m}$$

If  $\Delta N_{i,max}^{TTI,cm,m} = 0$ , then, for TrCH  $i$ , the output data of the rate matching is the same as the input data and the rate matching algorithm of subclause 4.2.7.5 does not need to be executed.

If  $\Delta N_{i,max}^{TTI,cm,m} \neq 0$ , then, for TrCH  $i$ , the rate matching algorithm of subclause 4.2.7.5 needs to be executed, and the parameters listed in subclauses 4.2.7.2.1.3 and 4.2.7.2.1.4 shall be used for determining  $e_{ini}$ ,  $e_{plus}$ , and  $e_{minus}$ , and  $\Delta N_{i,l}^{TTI,m}$ .

#### 4.2.7.2.1.3 Determination of rate matching parameters for uncoded and convolutionally encoded TrCHs

$$\Delta N_i = \Delta N_{i,max}$$

For compressed mode by puncturing,  $\Delta N_i$  is defined as:  $\Delta N_i = \Delta N_{i,max}^{TTI,cm,m}$ , instead of the previous relation.

$$a=2$$

$$N_{max} = \max_{l \in TFS(i)} N_{il}^{TTI}$$

For each transmission time interval of TrCH  $i$  with TF  $l$ , the rate-matching pattern is calculated with the algorithm in subclause 4.2.7.5. The following parameters are used as input:

$$X_i = N_{il}^{TTI}$$

$$e_{ini} = 1$$

$$e_{plus} = a \times N_{max}$$

$$e_{\min us} = a \times |\Delta N_i|$$

Puncturing if  $\Delta N_i < 0$ , repetition otherwise. The values of  $\Delta N_{i,l}^{TTI}$  may be computed by counting repetitions or puncturing when the algorithm of subclause 4.2.7.5 is run. The resulting values of  $\Delta N_{i,l}^{TTI}$  can be represented with following expression.

$$\Delta N_{i,l}^{TTI} = \left\lceil \frac{|\Delta N_i| \times X_i}{N_{max}} \right\rceil \times \text{sgn}(\Delta N_i)$$

For compressed mode by puncturing, the above formula produces  $\Delta N_{i,l}^{TTI,m}$  instead of  $\Delta N_{i,l}^{TTI}$ .

#### 4.2.7.2.1.4 Determination of rate matching parameters for Turbo encoded TrCHs

If repetition is to be performed on turbo encoded TrCHs, i.e.  $\Delta N_{i,max} > 0$ , the parameters in subclause 4.2.7.2.1.3 are used.

If puncturing is to be performed, the parameters below shall be used. Index  $b$  is used to indicate systematic ( $b=1$ ), 1<sup>st</sup> parity ( $b=2$ ), and 2<sup>nd</sup> parity bit ( $b=3$ ).

$$a=2 \text{ when } b=2$$

$$a=1 \text{ when } b=3$$

The bits indicated by  $b=1$  shall not be punctured.

$$\Delta N_i^b = \begin{cases} \left\lfloor \Delta N_{i,max} / 2 \right\rfloor, & \text{for } b=2 \\ \left\lceil \Delta N_{i,max} / 2 \right\rceil, & \text{for } b=3 \end{cases}$$

In Compressed Mode by puncturing, the following relations are used instead of the previous ones:

$$\Delta N_i^b = \left\lfloor \Delta N_{i,max}^{TTI,cm,m} / 2 \right\rfloor, \text{ for } b=2$$

$$\Delta N_{i,l}^b = \left\lceil \Delta N_{i,max}^{TTI,cm,m} / 2 \right\rceil, \text{ for } b=3$$

$$N_{max} = \max_{i \in TFS(i)} (N_{il}^{TTI} / 3)$$

For each transmission time interval of TrCH  $i$  with TF  $l$ , the rate-matching pattern is calculated with the algorithm in subclause 4.2.7.5. The following parameters are used as input:

$$X_i = N_{il}^{TTI} / 3$$

$$e_{ini} = N_{max}$$

$$e_{plus} = a \times N_{max}$$

$$e_{minus} = a \times |\Delta N_i^b|$$

The values of  $\Delta N_{i,l}^{TTI}$  may be computed by counting puncturing when the algorithm of subclause 4.2.7.5 is run. The resulting values of  $\Delta N_{i,l}^{TTI}$  can be represented with following expression.

$$\Delta N_{i,l}^{TTI} = - \left[ \frac{|\Delta N_i^2| \times X_i}{N_{max}} + 0.5 \right] - \left[ \frac{|\Delta N_i^3| \times X_i}{N_{max}} \right]$$

In the above equation, the first term of the right hand side represents the amount of puncturing for  $b=2$  and the second term represents the amount of puncturing for  $b=3$ .

For compressed mode by puncturing, the above formula produces  $\Delta N_{i,l}^{TTI,m}$  instead of  $\Delta N_{i,l}^{TTI}$ .

#### 4.2.7.2.2 Determination of rate matching parameters for flexible positions of TrCHs

##### 4.2.7.2.2.1 Calculations for normal mode, compressed mode by higher layer scheduling, and compressed mode by spreading factor reduction

First an intermediate calculation variable  $N_{ij}$  is calculated for all transport channels  $i$  and all transport format combinations  $j$  by the following formula:

$$N_{i,j} = \frac{1}{F_i} \times N_{i,TF_i(j)}^{TTI}$$

Then rate matching ratios  $RF_i$  are calculated for each the transport channel  $i$  in order to minimise the number of DTX bits when the bit rate of the CCTrCH is maximum. The  $RF_i$  ratios are defined by the following formula:

$$RF_i = \frac{N_{data,*}}{\max_{j \in TFCS} \sum_{l=1}^{i=l} (RM_i \times N_{i,j})} \times RM_i$$

The computation of  $\Delta N_{i,l}^{TTI}$  parameters is then performed in two phases. In a first phase, tentative temporary values of  $\Delta N_{i,l}^{TTI}$  are computed, and in the second phase they are checked and corrected. The first phase, by use of the  $RF_i$  ratios, ensures that the number of DTX indication bits inserted is minimum when the CCTrCH bit rate is maximum, but it does not ensure that the maximum CCTrCH bit rate is not greater than  $N_{data,*}$  per 10ms. The latter condition is ensured through the checking and possible corrections carried out in the second phase.

At the end of the second phase, the latest value of  $\Delta N_{i,l}^{TTI}$  is the definitive value.

The first phase defines the tentative temporary  $\Delta N_{i,l}^{TTI}$  for all transport channel  $i$  and any of its transport format  $l$  by use of the following formula:

$$\Delta N_{i,l}^{TTI} = F_i \times \left[ \frac{RF_i \times N_{i,l}^{TTI}}{F_i} \right] - N_{i,l}^{TTI} = F_i \times \left[ \frac{N_{data,*} \times RM_i \times N_{i,l}^{TTI}}{F_i \times \max_{j \in TFCS} \sum_{l=1}^i (RM_i \times N_{i,j})} \right] - N_{i,l}^{TTI}$$

The second phase is defined by the following algorithm:

for all  $j$  in  $TFCS$  in ascending order of TFCI do -- for all TFC

$$D = \sum_{i=1}^{i=l} \frac{N_{i,TF_i(j)}^{TTI} + \Delta N_{i,TF_i(j)}^{TTI}}{F_i} \quad \text{-- CCTrCH bit rate (bits per 10ms) for TFC } j$$

if  $D > N_{data,*}$  then

for  $i = 1$  to  $l$  do -- for all TrCH

$$\Delta N = F_i \times \Delta N_{i,j} \quad \text{-- } \Delta N_{i,j} \text{ is derived from } N_{i,j} \text{ by the formula given at subclause 4.2.7.}$$

if  $\Delta N_{i,TF_i(j)}^{TTI} > \Delta N$  then

$$\Delta N_{i,TF_i(j)}^{TTI} = \Delta N$$

end-if

end-for

end-if

end-for

If  $\Delta N_{i,l}^{TTI} = 0$  then, for TrCH  $i$  at TF  $l$ , the output data of the rate matching is the same as the input data and the rate matching algorithm of subclause 4.2.7.5 does not need to be executed.

If  $\Delta N_{i,l}^{TTI} \neq 0$  the parameters listed in subclauses 4.2.7.2.2.2 and 4.2.7.2.2.3 shall be used for determining  $e_{ini}$ ,  $e_{plus}$ , and  $e_{minus}$ .

#### 4.2.7.2.2.2 Determination of rate matching parameters for uncoded and convolutionally encoded TrCHs

$$\Delta N_i = \Delta N_{il}^{TTI}$$

$$a=2$$

For each transmission time interval of TrCH  $i$  with TF  $l$ , the rate-matching pattern is calculated with the algorithm in subclause 4.2.7.5. The following parameters are used as input:

$$X_i = N_{il}^{TTI}$$

$$e_{ini} = 1$$

$$e_{plus} = a \times N_{il}^{TTI}$$

$$e_{minus} = a \times |\Delta N_i|$$

puncturing for  $\Delta N_i < 0$ , repetition otherwise.

#### 4.2.7.2.2.3 Determination of rate matching parameters for Turbo encoded TrCHs

If repetition is to be performed on turbo encoded TrCHs, i.e.  $\Delta N_{il}^{TTI} > 0$ , the parameters in subclause 4.2.7.2.2.2 are used.

If puncturing is to be performed, the parameters below shall be used. Index  $b$  is used to indicate systematic ( $b=1$ ), 1<sup>st</sup> parity ( $b=2$ ), and 2<sup>nd</sup> parity bit ( $b=3$ ).

$$a=2 \text{ when } b=2$$

$$a=1 \text{ when } b=3$$

The bits indicated by  $b=1$  shall not be punctured.

$$\Delta N_i = \begin{cases} \left\lfloor \frac{\Delta N_{il}^{TTI}}{2} \right\rfloor, & b=2 \\ \left\lfloor \frac{\Delta N_{il}^{TTI}}{2} \right\rfloor, & b=3 \end{cases}$$

For each transmission time interval of TrCH  $i$  with TF  $i$ , the rate-matching pattern is calculated with the algorithm in subclause 4.2.7.5. The following parameters are used as input:

$$X_i = N_{ii}^{TTI} / 3,$$

$$e_{ini} = X_i,$$

$$e_{plus} = a \times X_i$$

$$e_{minus} = a \times |\Delta N_i|$$

#### 4.2.7.3 Bit separation and collection in uplink

The systematic bits of turbo encoded TrCHs shall not be punctured, the other bits may be punctured. The systematic bits, first parity bits, and second parity bits in the bit sequence input to the rate matching block are therefore separated into three sequences.

The first sequence contains:

- All of the systematic bits that are from turbo encoded TrCHs.
- From 0 to 2 first and/or second parity bits that are from turbo encoded TrCHs. These bits come into the first sequence when the total number of bits in a block after radio frame segmentation is not a multiple of three.
- Some of the systematic, first parity and second parity bits that are for trellis termination.

The second sequence contains:

- All of the first parity bits that are from turbo encoded TrCHs, except those that go into the first sequence when the total number of bits is not a multiple of three.
- Some of the systematic, first parity and second parity bits that are for trellis termination.

The third sequence contains:

- All of the second parity bits that are from turbo encoded TrCHs, except those that go into the first sequence when the total number of bits is not a multiple of three.
- Some of the systematic, first parity and second parity bits that are for trellis termination.

The second and third sequences shall be of equal length, whereas the first sequence can contain from 0 to 2 more bits. Puncturing is applied only to the second and third sequences. The bit separation function is transparent for uncoded TrCHs, convolutionally encoded TrCHs, and for turbo encoded TrCHs with repetition. The bit separation and bit collection are illustrated in figures 5 and 6.



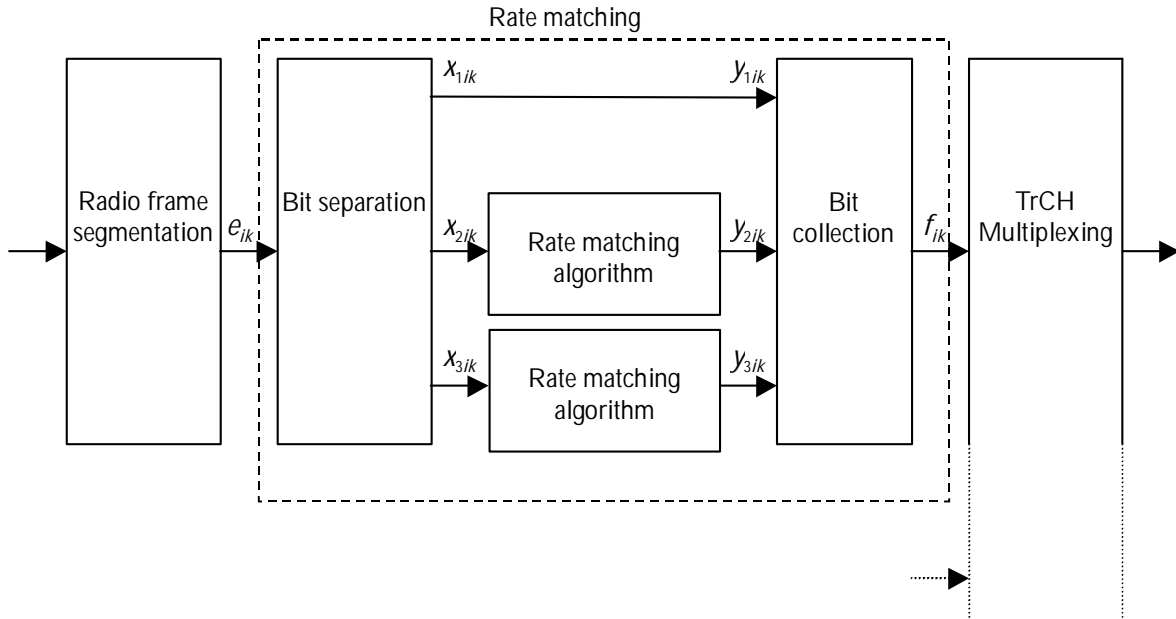

Figure 5: Puncturing of turbo encoded TrCHs in uplink

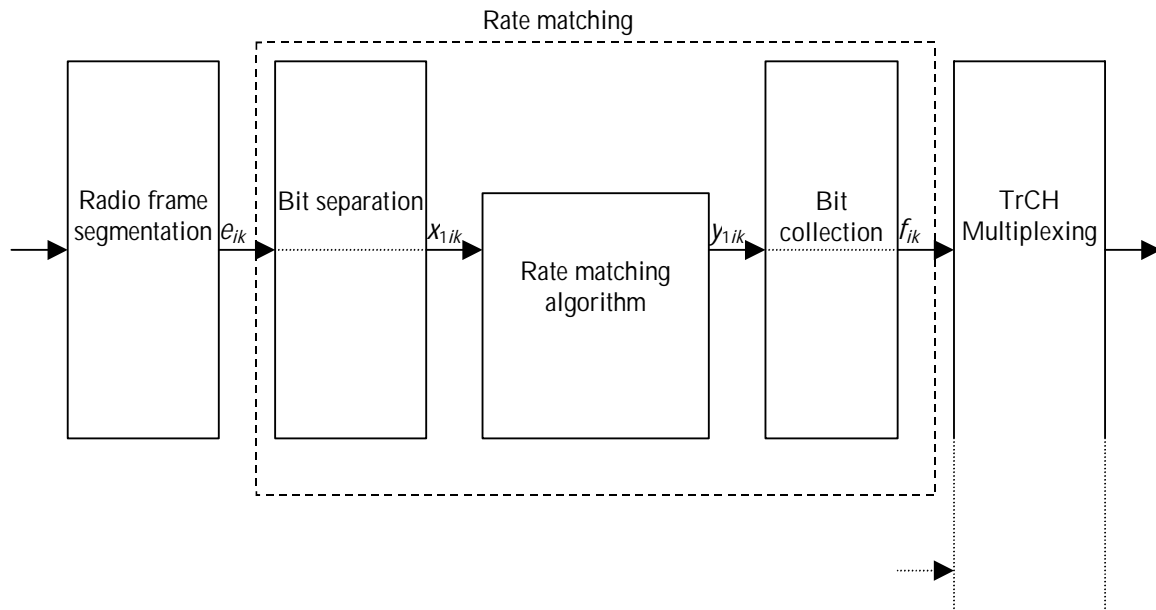

Figure 6: Rate matching for uncoded TrCHs, convolutionally encoded TrCHs, and for turbo encoded TrCHs with repetition in uplink

The bit separation is dependent on the 1<sup>st</sup> interleaving and offsets are used to define the separation for different TTIs.  $b$  indicates the three sequences defined in this section, with  $b=1$  indicating the first sequence,  $b = 2$  the second one, and  $b = 3$  the third one. The offsets  $\alpha_b$  for these sequences are listed in table 5.

Table 5: TTI dependent offset needed for bit separation

TTI (ms)	$\alpha_1$	$\alpha_2$	$\alpha_3$
10, 40	0	1	2
20, 80	0	2	1

The bit separation is different for different radio frames in the TTI. A second offset is therefore needed. The radio frame number for TrCH  $i$  is denoted by  $n_i$ , and the offset by  $\beta_{n_i}$ .

**Table 6: Radio frame dependent offset needed for bit separation**

TTI (ms)	$\beta_0$	$\beta_1$	$\beta_2$	$\beta_3$	$\beta_4$	$\beta_5$	$\beta_6$	$\beta_7$
10	0	NA	NA	NA	NA	NA	NA	NA
20	0	1	NA	NA	NA	NA	NA	NA
40	0	1	2	0	NA	NA	NA	NA
80	0	1	2	0	1	2	0	1

#### 4.2.7.3.1 Bit separation

The bits input to the rate matching are denoted by  $e_{i1}, e_{i2}, e_{i3}, \dots, e_{iN_i}$ , where  $i$  is the TrCH number and  $N_i$  is the number of bits input to the rate matching block. Note that the transport format combination number  $j$  for simplicity has been left out in the bit numbering, i.e.  $N_i = N_{ij}$ . The bits after separation are denoted by  $X_{bi1}, X_{bi2}, X_{bi3}, \dots, X_{biX_i}$ . For turbo encoded TrCHs with puncturing,  $b$  indicates the three sequences defined in section 4.2.7.3, with  $b=1$  indicating the first sequence, and so forth. For all other cases  $b$  is defined to be 1.  $X_i$  is the number of bits in each separated bit sequence. The relation between  $e_{ik}$  and  $X_{bik}$  is given below.

For turbo encoded TrCHs with puncturing:

$$X_{1,i,k} = e_{i,3(k-1)+1+(\alpha_1+\beta_{n_i}) \bmod 3} \quad k = 1, 2, 3, \dots, X_i \quad X_i = \lfloor N_i/3 \rfloor$$

$$X_{1,i,\lfloor N_i/3 \rfloor + k} = e_{i,3\lfloor N_i/3 \rfloor + k} \quad k = 1, \dots, N_i \bmod 3 \quad \text{Note: When } (N_i \bmod 3) = 0 \text{ this row is not needed.}$$

$$X_{2,i,k} = e_{i,3(k-1)+1+(\alpha_2+\beta_{n_i}) \bmod 3} \quad k = 1, 2, 3, \dots, X_i \quad X_i = \lfloor N_i/3 \rfloor$$

$$X_{3,i,k} = e_{i,3(k-1)+1+(\alpha_3+\beta_{n_i}) \bmod 3} \quad k = 1, 2, 3, \dots, X_i \quad X_i = \lfloor N_i/3 \rfloor$$

For uncoded TrCHs, convolutionally encoded TrCHs, and turbo encoded TrCHs with repetition:

$$X_{1,i,k} = e_{i,k} \quad k = 1, 2, 3, \dots, X_i \quad X_i = N_i$$

#### 4.2.7.3.2 Bit collection

The bits  $X_{bik}$  are input to the rate matching algorithm described in subclause 4.2.7.5. The bits output from the rate matching algorithm are denoted  $Y_{bi1}, Y_{bi2}, Y_{bi3}, \dots, Y_{biY_i}$ .

Bit collection is the inverse function of the separation. The bits after collection are denoted by  $Z_{bi1}, Z_{bi2}, Z_{bi3}, \dots, Z_{biY_i}$ .

After bit collection, the bits indicated as punctured are removed and the bits are then denoted by  $f_{i1}, f_{i2}, f_{i3}, \dots, f_{iV_i}$ , where  $i$  is the TrCH number and  $V_i = N_{ij} + \Delta N_{ij}$ . The relations between  $y_{bik}$ ,  $Z_{bik}$ , and  $f_{ik}$  are given below.

For turbo encoded TrCHs with puncturing ( $Y_i = X_i$ ):

$$Z_{i,3(k-1)+1+(\alpha_1+\beta_{n_i}) \bmod 3} = Y_{1,i,k} \quad k = 1, 2, 3, \dots, Y_i$$

$$Z_{i,3\lfloor N_i/3 \rfloor + k} = Y_{1,i,\lfloor N_i/3 \rfloor + k} \quad k = 1, \dots, N_i \bmod 3 \quad \text{Note: When } (N_i \bmod 3) = 0 \text{ this row is not needed.}$$

$$Z_{i,3(k-1)+1+(\alpha_2+\beta_{n_i}) \bmod 3} = Y_{2,i,k} \quad k = 1, 2, 3, \dots, Y_i$$

$$Z_{i,3(k-1)+1+(\alpha_3+\beta_{n_i}) \bmod 3} = Y_{3,i,k} \quad k = 1, 2, 3, \dots, Y_i$$

After the bit collection, bits  $Z_{i,k}$  with value  $\delta$ , where  $\delta \in \{0, 1\}$ , are removed from the bit sequence. Bit  $f_{i,1}$  corresponds to the bit  $Z_{i,k}$  with smallest index  $k$  after puncturing, bit  $f_{i,2}$  corresponds to the bit  $Z_{i,k}$  with second smallest index  $k$  after puncturing, and so on.

For uncoded TrCHs, convolutionally encoded TrCHs, and turbo encoded TrCHs with repetition:

$$Z_{i,k} = Y_{1,i,k} \quad k = 1, 2, 3, \dots, Y_i$$

When repetition is used,  $f_{i,k} = Z_{i,k}$  and  $Y_i = V_i$ .

When puncturing is used,  $Y_i = X_i$  and bits  $Z_{i,k}$  with value  $\delta$ , where  $\delta \in \{0, 1\}$ , are removed from the bit sequence. Bit  $f_{i,1}$  corresponds to the bit  $Z_{i,k}$  with smallest index  $k$  after puncturing, bit  $f_{i,2}$  corresponds to the bit  $Z_{i,k}$  with second smallest index  $k$  after puncturing, and so on.

#### 4.2.7.4 Bit separation and collection in downlink

The systematic bits of turbo encoded TrCHs shall not be punctured, the other bits may be punctured.

The systematic bits, first parity bits and second parity bits in the bit sequence input to the rate matching block are therefore separated into three sequences of equal lengths.

The first sequence contains :

- All of the systematic bits that are from turbo encoded TrCHs.
- Some of the systematic, first parity and second parity bits that are for trellis termination.

The second sequence contains:

- All of the first parity bits that are from turbo encoded TrCHs.
- Some of the systematic, first parity and second parity bits that are for trellis termination.

The third sequence contains:

- All of the second parity bits that are from turbo encoded TrCHs.
- Some of the systematic, first parity and second parity bits that are for trellis termination.

Puncturing is applied only to the second and third sequences.

The bit separation function is transparent for uncoded TrCHs, convolutionally encoded TrCHs, and for turbo encoded TrCHs with repetition. The bit separation and bit collection are illustrated in figures 7 and 8.

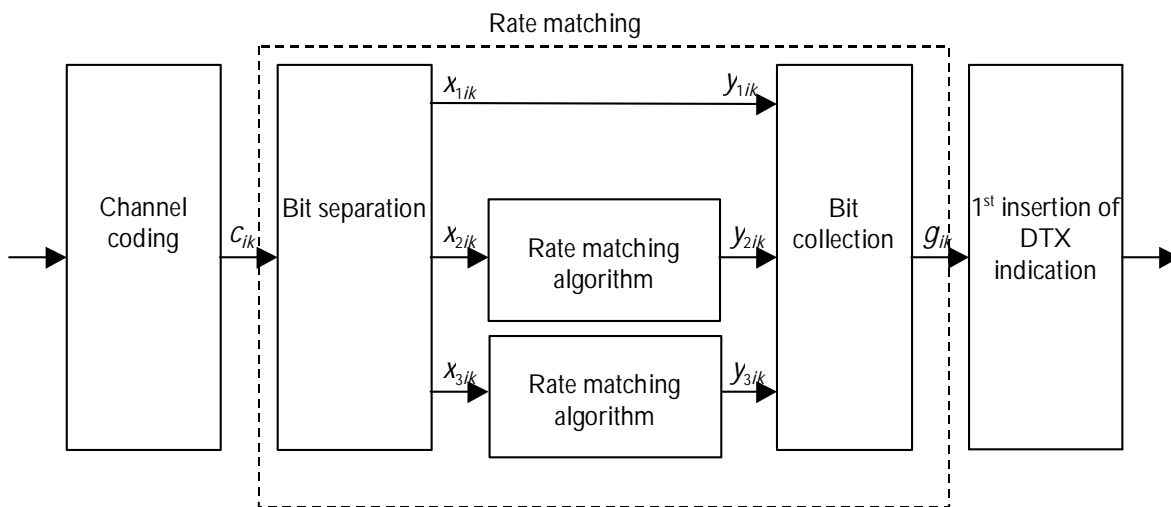
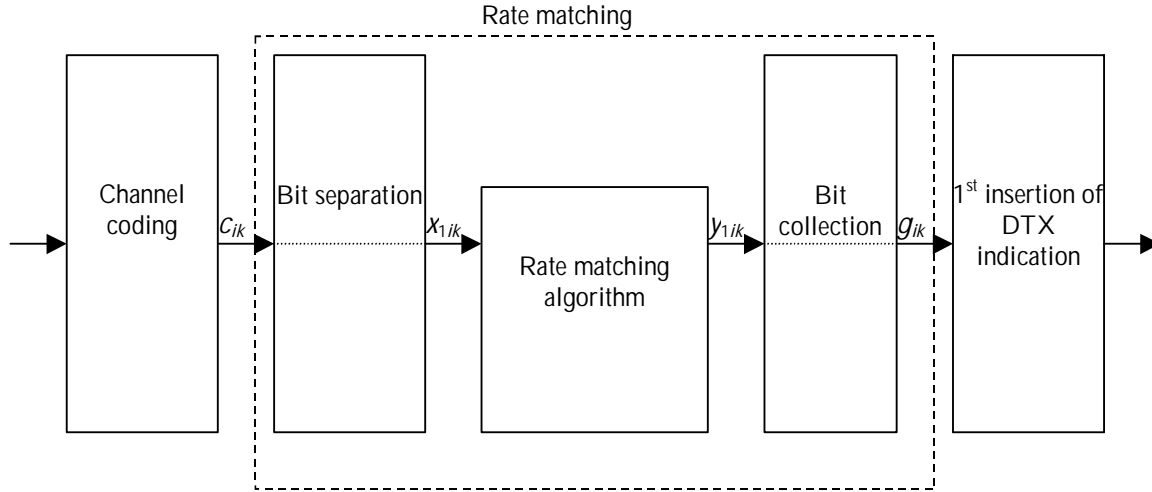

Figure 7: Puncturing of turbo encoded TrCHs in downlink



**Figure 8: Rate matching for uncoded TrCHs, convolutionally encoded TrCHs, and for turbo encoded TrCHs with repetition in downlink**

#### 4.2.7.4.1 Bit separation

The bits input to the rate matching are denoted by  $C_{i1}, C_{i2}, C_{i3}, \dots, C_{iE_i}$ , where  $i$  is the TrCH number and  $E_i$  is the number of bits input to the rate matching block. Note that  $E_i$  is a multiple of 3 for turbo encoded TrCHs and that the transport format  $T$  for simplicity has been left out in the bit numbering, i.e.  $E_i = N_{ii}^{TTI}$ . The bits after separation are denoted by  $X_{bi1}, X_{bi2}, X_{bi3}, \dots, X_{biX_i}$ . For turbo encoded TrCHs with puncturing,  $b$  indicates the three sequences defined in section 4.2.7.4, with  $b=1$  indicating the first sequence, and so forth. For all other cases  $b$  is defined to be 1.  $X_i$  is the number of bits in each separated bit sequence. The relation between  $C_{ik}$  and  $X_{bik}$  is given below.

For turbo encoded TrCHs with puncturing:

$$X_{1,i,k} = C_{i,3(k-1)+1} \quad k = 1, 2, 3, \dots, X_i \quad X_i = E_i/3$$

$$X_{2,i,k} = C_{i,3(k-1)+2} \quad k = 1, 2, 3, \dots, X_i \quad X_i = E_i/3$$

$$X_{3,i,k} = C_{i,3(k-1)+3} \quad k = 1, 2, 3, \dots, X_i \quad X_i = E_i/3$$

For uncoded TrCHs, convolutionally encoded TrCHs, and turbo encoded TrCHs with repetition:

$$X_{1,i,k} = C_{i,k} \quad k = 1, 2, 3, \dots, X_i \quad X_i = E_i$$

#### 4.2.7.4.2 Bit collection

The bits  $X_{bik}$  are input to the rate matching algorithm described in subclause 4.2.7.5. The bits output from the rate matching algorithm are denoted  $Y_{bi1}, Y_{bi2}, Y_{bi3}, \dots, Y_{biY_i}$ .

Bit collection is the inverse function of the separation. The bits after collection are denoted by  $Z_{bi1}, Z_{bi2}, Z_{bi3}, \dots, Z_{biY_i}$ . After bit collection, the bits indicated as punctured are removed and the bits are then denoted by  $g_{i1}, g_{i2}, g_{i3}, \dots, g_{iG_i}$ , where  $i$  is the TrCH number and  $G_i = N_{ii}^{TTI} + \Delta N_{ii}^{TTI}$ . The relations between  $Y_{bik}$ ,  $Z_{bik}$ , and  $g_{ik}$  are given below.

For turbo encoded TrCHs with puncturing ( $Y_i = X_i$ ):

$$Z_{i,3(k-1)+1} = Y_{1,i,k} \quad k = 1, 2, 3, \dots, Y_i$$

$$Z_{i,3(k-1)+2} = Y_{2,i,k} \quad k = 1, 2, 3, \dots, Y_i$$

$$Z_{i,3(k-1)+3} = Y_{3,i,k} \quad k = 1, 2, 3, \dots, Y_i$$

After the bit collection, bits  $Z_{i,k}$  with value  $\delta_i$ , where  $\delta_i \notin \{0, 1\}$ , are removed from the bit sequence. Bit  $g_{i,1}$  corresponds to the bit  $Z_{i,k}$  with smallest index  $k$  after puncturing, bit  $g_{i,2}$  corresponds to the bit  $Z_{i,k}$  with second smallest index  $k$  after puncturing, and so on.

For uncoded TrCHs, convolutionally encoded TrCHs, and turbo encoded TrCHs with repetition:

$$Z_{i,k} = Y_{1,i,k} \quad k = 1, 2, 3, \dots, Y_i$$

When repetition is used,  $g_{i,k} = Z_{i,k}$  and  $Y_i = G_i$ .

When puncturing is used,  $Y_i = X_i$  and bits  $Z_{i,k}$  with value  $\delta_i$ , where  $\delta_i \notin \{0, 1\}$ , are removed from the bit sequence. Bit  $g_{i,1}$  corresponds to the bit  $Z_{i,k}$  with smallest index  $k$  after puncturing, bit  $g_{i,2}$  corresponds to the bit  $Z_{i,k}$  with second smallest index  $k$  after puncturing, and so on.

#### 4.2.7.5 Rate matching pattern determination

Denote the bits before rate matching by:

$X_{i,1}, X_{i,2}, X_{i,3}, \dots, X_{i,X_i}$ , where  $i$  is the TrCH number and the sequence is defined in 4.2.7.3 for uplink or in 4.2.7.4 for downlink. Parameters  $X_i$ ,  $e_{ini}$ ,  $e_{plus}$ , and  $e_{minus}$  are given in 4.2.7.1 for uplink or in 4.2.7.2 for downlink.

The rate matching rule is as follows:

if puncturing is to be performed

$e = e_{ini}$       -- initial error between current and desired puncturing ratio

$m = 1$       -- index of current bit

do while  $m \leq X_i$

$e = e - e_{minus}$       -- update error

if  $e \leq 0$  then      -- check if bit number  $m$  should be punctured

    set bit  $x_{i,m}$  to  $\delta$  where  $\delta \notin \{0, 1\}$

$e = e + e_{plus}$       -- update error

end if

$m = m + 1$       -- next bit

end do

else

$e = e_{ini}$       -- initial error between current and desired puncturing ratio

$m = 1$       -- index of current bit

do while  $m \leq X_i$

$e = e - e_{minus}$       -- update error

do while  $e \leq 0$       -- check if bit number  $m$  should be repeated

    repeat bit  $x_{i,m}$

$e = e + e_{plus}$       -- update error

Error! No text of specified style in document.

38

Error! No text of specified style in document.

end do

$m = m + 1$       -- *next bit*

end do

end if

A repeated bit is placed directly after the original one.