

Source: LG Electronics

Title: CR for TR 25.841: DSCH Power control Improvement in soft handover

Document for: Approval

1. Introduction

In WG1 #17 meeting, we proposed and discussed TFCI power control in split mode[1]. In split mode, TFCI2 (TFCI for DSCH) is not transmitted from all the cells in the active set when UE is in the soft handover region. Thus, the reliability of TFCI cannot be guaranteed in this case. As well, current specification assigns TFCI power (PO1) when Radio Link is established. Therefore, power offset should be set high enough to detect TFCI bits reliably even if UE is not in the soft handover region [2].

To solve this problem, it is proposed that the power control for DSCH should be applied to that of TFCI. When the power control of DSCH is combined with SSDT, different power offsets are applied to TFCI. Like DSCH power offset, TFCI power offset is adjusted by UE location (i.e. in the soft handover region or in the non-soft handover region), and it is also determined whether the cell transmitting DSCH is primary or non-primary cell. Therefore, three TFCI power offsets such as PO1, primary_PO1 and non-primary_PO1 are required.

It was decided that the proposal [1] would be discussed in the context beyond R4, and the related text would be included in [3]. This CR includes the text for TFCI power control improvement in TR 25.841.

2. Reference

[1] TSG R1-00-1429, Power control of TFCI field for DSCH in soft handover, LG Electronics.

[2] TSG R1-01-125, TFCI power control in split mode, LG Electronics.

[3] TR 25.841, DSCH power control improvement in soft handover.

CR-Formv3	
CHANGE REQUEST	
✂ 25.841 CR 001 ✂ rev 1 ✂ Current version: 4.0.0 ✂	

For **HELP** on using this form, see bottom of this page or look at the pop-up text over the ✂ symbols.

Proposed change affects: ✂ (U)SIM ME/UE Radio Access Network Core Network

Title:	✂ TFCI power control for DSCH in split mode ✂		
Source:	✂ LG Electronics ✂		
Work item code:	✂	Date:	✂ 2001-02-28 ✂
Category:	✂ B ✂	Release:	✂ REL-4 ✂
Use <u>one</u> of the following categories: F (essential correction) A (corresponds to a correction in an earlier release) B (Addition of feature), C (Functional modification of feature) D (Editorial modification) Detailed explanations of the above categories can be found in 3GPP TR 21.900.		Use <u>one</u> of the following releases: 2 (GSM Phase 2) R96 (Release 1996) R97 (Release 1997) R98 (Release 1998) R99 (Release 1999) REL-4 (Release 4) REL-5 (Release 5)	

Reason for change:	✂ TFCI for DSCH is not transmitted from all Node B. To detect TFCI reliably and assign reliable power to the TFCI field, the TFCI power should be controlled by the power control of DSCH. This introduces additional feature beyond R4. ✂
Summary of change:	✂ To introduce the TFCI power control for DSCH in split mode . ✂
Consequences if not approved:	✂

Clauses affected:	✂ 6.2.3 ✂	
Other specs affected:	<input type="checkbox"/> Other core specifications ✂ <input type="checkbox"/> Test specifications ✂ <input type="checkbox"/> O&M Specifications ✂	✂
Other comments:	✂	

How to create CRs using this form:

Comprehensive information and tips about how to create CRs can be found at: http://www.3gpp.org/3G_Specs/CRs.htm. Below is a brief summary:

- 1) Fill out the above form. The symbols above marked ✂ contain pop-up help information about the field that they are closest to.
- 2) Obtain the latest version for the release of the specification to which the change is proposed. Use the MS Word "revision marks" feature (also known as "track changes") when making the changes. All 3GPP specifications can be downloaded from the 3GPP server under <ftp://www.3gpp.org/specs/> For the latest version, look for the directory name with the latest date e.g. 2000-09 contains the specifications resulting from the September 2000 TSG meetings.
- 3) With "track changes" disabled, paste the entire CR form (use CTRL-A to select it) into the specification just in front of the clause containing the first piece of changed text. Delete those parts of the specification which are not relevant to the change request.

Contents

Foreword	4
1 Scope	5
2 References.....	5
3 Definitions, symbols and abbreviations	5
3.1 Definitions.....	5
3.2 Symbols	5
3.3 Abbreviations	5
4 Background and Introduction.....	5
5 Changes over the Release –99 specification based equipment for the proposed method.....	6
5.1 Changes with respect to Release 99.....	6
5.1.1 Required Changes in UE.....	6
5.1.2 Required Changes in Node B.....	6
5.2 Expected Gain with respect to Release 99.....	6
6 DSCH Power Control Improvement	6
6.1 Fast DSCH power control combined with SSDT	6
6.2 Other solutions.....	7
6.2.1 Block error indication method.....	7
Description	7
Benefits	7
Drawbacks	8
6.2.2 SIR based method.....	8
Description	8
Benefits	8
Drawbacks	8
<u>6.2.3 TFCI Power control for DSCH in split mode.....</u>	<u>Error! Bookmark not defined.9</u>
<u>TFCI power control relying on SSDT signalling.....</u>	<u>Error! Bookmark not defined.9</u>
<u>TFCI power control with separate feedback.....</u>	<u>Error! Bookmark not defined.9</u>
7 Impacts to TSG RAN specifications	<u>889</u>
7.1 WG1	<u>889</u>
7.2 WG2	<u>111011</u>
7.3 WG3	11
7.4 WG4	11
8 Backward Compatibility.....	<u>111112</u>
Annex A (informative): Change history	<u>121213</u>

Foreword

This Technical Specification has been produced by the 3rd Generation Partnership Project (3GPP). The contents of the present document are subject to continuing work within the TSG and may change following formal TSG approval. Should the TSG modify the contents of the present document, it will be re-released by the TSG with an identifying change of release date and an increase in version number as follows:

Version x.y.z

where:

- x the first digit:
 - 1 presented to TSG for information;
 - 2 presented to TSG for approval;
 - 3 or greater indicates TSG approved document under change control.
- y the second digit is incremented for all changes of substance, i.e. technical enhancements, corrections, updates, etc.
- z the third digit is incremented when editorial only changes have been incorporated in the document.

1 Scope

This document is the Technical Report for the DSCH power control improvement in soft handover, part of the Release 4 work item "DSCH power control improvement in soft handover".

2 References

The following documents contain provisions which, through reference in this text, constitute provisions of the present document.

?? References are either specific (identified by date of publication, edition number, version number, etc.) or non-specific.

?? For a specific reference, subsequent revisions do not apply.

?? For a non-specific reference, the latest version applies.

[1] 3G TS 25.214 (V3.2.0):

[2] 3G TR 25.849

3 Definitions, symbols and abbreviations

3.1 Definitions

For the purposes of the present document, the following terms and definitions apply.

Example: text used to clarify abstract rules by applying them literally.

3.2 Symbols

3.3 Abbreviations

For the purposes of the present document, the following abbreviations apply:

DCH	Dedicated Channel
DPCCH	Dedicated Physical Control Channel
FBI	Feedback Information
PDSCH	Physical Downlink Shared Channel
SSDT	Site Selection Diversity Transmission
SHO	Soft Handover
DSCH	Downlink Shared Channel

4 Background and Introduction

Under the study item "Radio Link Performance Improvement", the proposal for "DSCH power control improvement in soft handover" has been discussed in TSG RAN WG1. Based on the progress in WG1 a work item was agreed in TSG RAN#9 under the name DSCH power control improvement in soft handover. In this technical report, the details of the proposed method are presented as well as the required changes in different specifications in TSG RAN specifications. Additional technical report has been created to cover the WG3 part separately, see [2] for details on the Iur & Iub impacts.

5 Changes over the Release –99 specification based equipment for the proposed method

This section covers the expected changes for the Release –99 based equipment to support the feature.

5.1 Changes with respect to Release 99

5.1.1 Required Changes in UE

At the UE side the new "capability" needed is to be able to do the normal soft handover even when sending the SSdT signalling in the uplink direction. This should not be a hardware issue; thus the incremental complexity is very small. Both such a "normal" SHO combining and SSdT signalling are "mandatory" requirements for the UE in Release –99.

5.1.2 Required Changes in Node B

For the Node B side the proposed method is giving a possibility to improve the resulting performance in setting the DSCH power level and from Release –99 specification the added complexity is also very small as only the power control algorithm in the Node B (for DSCH) would need to be modified.

In general it is also worth noting that this kind of item is optional in the Node B (or UTRAN in general).

5.2 Expected Gain with respect to Release 99

The performance improvements can be considered coming from the following case:

With the proposed method, The DSCH would be sent with more accurate power level, as UTRAN would utilise the information from the SSdT to see if the Node B/cell sending the DSCH is the strongest one. In the worst case with DSCH being sent from the weakest Node B, the DSCH power level could be 6-10dB below the desired power level. This corresponds also to a more or less non-power controlled case or random power controlled case as the associated DCH is not the basis for the power control commands generated by the UE.

6 DSCH Power Control Improvement

6.1 Fast DSCH power control combined with SSdT

In this section, the method for the DSCH power control improvement is described.

The proposed intends to allow the improvement of DSCH power control in soft handover by the use of the existing SSdT signalling in the uplink to determine whether DSCH power should follow the DCH (primary cell transmitting) or whether the DSCH power should be set with higher offset (or fixed value like for FACH (Forward Access Channel) for example) in case secondary cell is transmitting.

The SSdT has been specified in section 5.2.1.4 in [1] and according to the principle UE provides indication of the primary cell ID for in the uplink FBI field. This feature is considered as baseline feature and provided by all UEs (that can use dedicated channels) in the Release –99 as well. The intention with SSdT is that only the primary cell sends the DPDCH part of the downlink DCH, while DPCCH part is sent by the all Node Bs in the active set.

In the proposed enhancement, the UTRAN may activate the uplink SSdT signalling even the SSdT transmission is not necessary used on the downlink DCH. The Node Bs are given power offset value that is used whether the DSCH is sent from the Node B determined to be the primary Node B (or cell) or whether the Node B sending the DSCH is the secondary one. The primary/secondary status would be determined with sliding average for example over 10 frames with parameter given (over Iub) how many primary indications are needed to use the primary value power offset for DSCH.

The existing maximum/minimum power level values would be naturally valid, thus allowing to set the DSCH e.g. to be 6 dB over DCH but not to exceed the power level determined as being needed for example with FACH transmission.

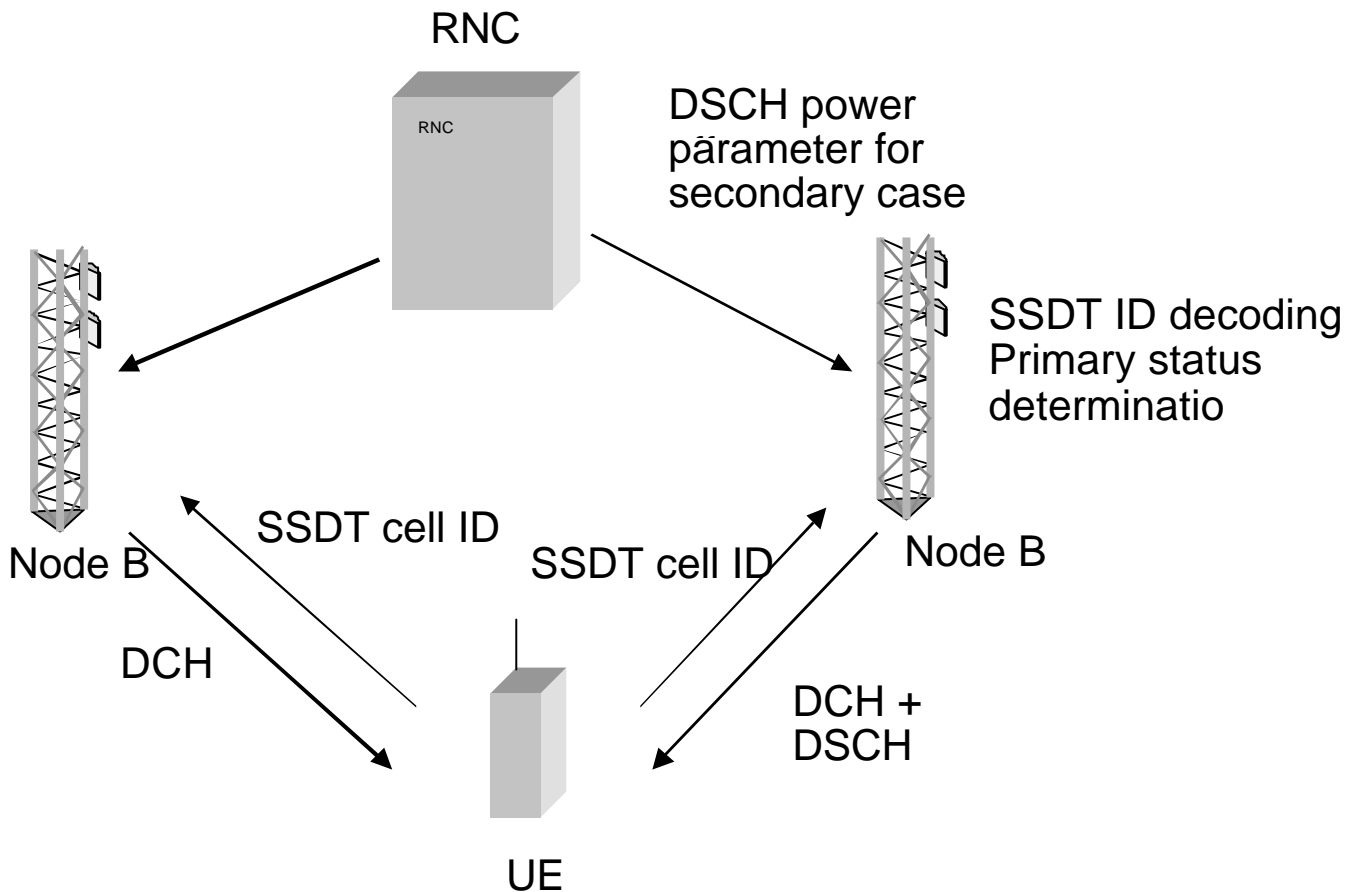

Figure 1. Concept of using SSDT signalling with DSCH power control

6.2 Other solutions.

The method presented in section 6.1 fits nicely in the R'4 context as it does not involve any hardware modification. However, it does not fully solve the PDSCH power control issue and has a number of drawbacks. In particular, the proposed method:

- ?? Only improves the performance in some very specific scenarios (unbalanced active set power distribution).
- ?? Could actually degrade the performance in some specific scenarios (balanced active set, error in cell selection)
- ?? Potentially decreases the average interference generated by PDSCH but does not necessarily provide additional capacity in power limited situation as the base station has to set aside the power required for fixed power or fixed offset PDSCH transmission in case the power control "mode" suddenly changes (switching between the two modes can not be predicted).

The following sub sections briefly presents two other possible solutions which are expected to provide additional gains (compared to solution in section 6.1) at the expense of potential HW modifications in the UE or Node B (compared to R'99). Those methods and their respective performance should be considered in more details in the context of releases beyond R'4.

6.2.1 Block error indication method

Description

The UE sends a 100 Hz, 1 bit, feedback to the network indicating whether any of the blocks in the previous frame has been received in error (based on CRC check). In case no TTI with CRC ended in the previous frame, the Node B knows it and discards the information sent by the UE. The information is sent by stealing one power control slot per frame on the associated DPCH.

Benefits

- ?? Does not require any change in the UE HW.

Drawbacks

- ?? Performance gain depends on transport channel configuration (CRC, TTI).
- ?? Since CRC is used for the outer loop and at least one transport channel is expected to include CRC integrity protection, CRC will, in principle, be available in most cases. However, depending on the TTI of the TrCH with CRC protection, the effective feedback rate could be 100 Hz (10 ms TTI), 50 Hz (20 ms TTI), 25 Hz (40 ms TTI) or 12.5 Hz (80 ms TTI).
- ?? Power control loop is not maintained when no data is sent over the PDSCH

6.2.2 SIR based method

Description

The UE derives an independent power control command based on the PDSCH symbols (non-coherent accumulation, PDSCH TFC is known in advance) and steals every 3, 5 or 15 slots of the associated DPCH UL power control stream to transmit the PDSCH power control commands. Alternatively, new UL slot structure could be defined.

Benefits

- ?? Full fast inner loop power control solution fully correlated with the fading experienced by the PDSCH.

Drawbacks

- ?? Requires the introduction of a specific PDSCH power control decision algorithm in the UE. The complexity increase is not expected to be significant but might require HW changes.
- ?? In case new UL slot formats are defined the Node B HW might also have to be modified.
- ?? Power control loop is not maintained when no data is sent over the PDSCH.

6.2.3 TFCI Power control for DSCH in split mode

In this subsection is presented the power control of TFCI in a cell transmitting DSCH when the TFCI is in split mode. In split mode, TFCI2 (TFCI for DSCH) is not transmitted from all the cells in the active set when the UE is in soft handover. Thus the reliability of TFCI cannot be guaranteed. As well, in the current specification, the power offset should be set high enough to always detect TFCI bits reliably even if UE is not in soft handover. To solve the problem of ensuring reliable detection without a large offset, it is proposed that the power control for DSCH should be applied to the TFCI. The benefits of this method may be considered in more details in the context of releases beyond R4. In addition, the impacts to other WGs should be considered.

Two approaches which could be considered are:-

TFCI power control relying on SSdT signalling

TFCI power control is described when the power control of DSCH is using the existing SSdT signaling. In DSCH power control, the primary or non-primary status is determined by SSdT signaling over an averaging window. A different TFCI power offset is assigned according to this status. Thus, there would exist three kinds of power offset for TFCI.

TFCI power control with separate feedback

TFCI power control is operated with either Block error indication method or SIR based method in sections 6.2.1 and 6.2.2. The power value for TFCI is adjusted by using the separate feedback for DSCH power control.

7 Impacts to TSG RAN specifications

7.1 WG1

This section contains the draft changes to TSG RAN WG1 TS 25.214. Editing note: The revision marks in the section on WG1 specifications indicate the changes with respect to TS 25.214 v.3.3.0 and should be retained to indicate the difference. Further work is to continue with draft CRs in WG1 on the issue based on the latest version of the 25.214..

5.2.1.4 Site selection diversity transmit power control

5.2.1.4.1 General

Site selection diversity transmit power control (SSDT) is an optional macro diversity method in soft handover mode. Operation is summarised as follows. The UE selects one of the cells from its active set to be 'primary', all other cells are classed as 'non primary'. The main objective is to transmit on the downlink from the primary cell, thus reducing the interference caused by multiple transmissions in a soft handover mode. A second objective is to achieve fast site selection without network intervention, thus maintaining the advantage of the soft handover. In order to select a primary cell, each cell is assigned a temporary identification (ID) and UE periodically informs a primary cell ID to the connecting cells. The non-primary cells selected by UE switch off the transmission power. The primary cell ID is delivered by UE to the active cells via uplink FBI field. SSDT activation, SSDT termination and ID assignment are all carried out by higher layer signalling.

UTRAN may also command UE to use SSDT signalling in the uplink although cells would transmit the downlink as without SSDT active. The downlink operation mode for SSDT is set by higher layers. UTRAN may use the SSDT information for the PDSCH power control as specified in section 5.2.2.

5.2.1.4.1.1 Definition of temporary cell identification

Each cell is given a temporary ID during SSDT and the ID is utilised as site selection signal. The ID is given a binary bit sequence. There are three different lengths of coded ID available denoted as "long", "medium" and "short". The network decides which length of coded ID is used. Settings of ID codes for 1-bit and 2-bit FBI are exhibited in table 3 and table 4, respectively.

Table 3: Settings of ID codes for 1 bit FBI

ID label	ID code		
	"long"	"medium"	"short"
a	0000000000000000	(0)0000000	00000
b	101010101010101	(0)1010101	01001
c	011001100110011	(0)0110011	11011
d	110011001100110	(0)1100110	10010
e	000111100001111	(0)0001111	00111
f	101101001011010	(0)1011010	01110
g	011110000111100	(0)0111100	11100
h	110100101101001	(0)1101001	10101

Table 4: Settings of ID codes for 2 bit FBI

ID label	ID code (Column and Row denote slot position and FBI-bit position.)		
	"long"	"medium"	"short"
a	(0)0000000	(0)000	000
	(0)0000000	(0)000	000
b	(0)0000000	(0)000	000
	(1)1111111	(1)111	111
c	(0)1010101	(0)101	101
	(0)1010101	(0)101	101
d	(0)1010101	(0)101	101
	(1)0101010	(1)010	010
e	(0)0110011	(0)011	011
	(0)0110011	(0)011	011
f	(0)0110011	(0)011	011
	(1)1001100	(1)100	100
g	(0)1100110	(0)110	110
	(0)1100110	(0)110	110
h	(0)1100110	(0)110	110
	(1)0011001	(1)001	001

ID must be terminated within a frame. If FBI space for sending a given ID cannot be obtained within a frame, hence if the entire ID is not transmitted within a frame but must be split over two frames, the first bit(s) of the ID is(are) punctured. The relating bit(s) to be punctured are shown with brackets in table 3 and table 4.

5.2.1.4.2 TPC procedure in UE

The TPC procedure of the UE in SSDT is identical to that described in subclause 5.2.1.2 or 5.2.1.3 in compressed mode.

5.2.1.4.3 Selection of primary cell

The UE selects a primary cell periodically by measuring the RSCP of CPICHs transmitted by the active cells. The cell with the highest CPICH RSCP is detected as a primary cell.

5.2.1.4.4 Delivery of primary cell ID

The UE periodically sends the ID code of the primary cell via portion of the uplink FBI field assigned for SSdT use (FBI S field). A cell recognises its state as non-primary if the following conditions are fulfilled simultaneously:

- the received primary ID code does not match with the own ID code;
- the received uplink signal quality satisfies a quality threshold, Q_{th} , a parameter defined by the network;
- and when the use of uplink compressed mode does not result in excessive levels of puncturing on the coded ID. The acceptable level of puncturing on the coded ID is less than $(int)N_{ID}/3$ symbols in the coded ID, where N_{ID} is the length of the coded ID.

Otherwise the cell recognises its state as primary.

The state of the cells (primary or non-primary) in the active set is updated synchronously. If a cell receives the last portion of the coded ID in uplink slot j , the state of cell is updated in downlink slot $(j+1+T_{os}) \bmod 15$, where T_{os} is defined as a constant of 2 time slots. The updating of the cell state is not influenced by the operation of downlink compressed mode.

At the UE, the primary ID code to be sent to the cells is segmented into a number of portions. These portions are distributed in the uplink FBI S-field. The cell in SSdT collects the distributed portions of the primary ID code and then detects the transmitted ID. The period of the primary cell update depends on the settings of the code length and the number of FBI bits assigned for SSdT use as shown in table 5.

Table 5: Period of primary cell update

code length	The number of FBI bits per slot assigned for SSdT	
	1	2
"long"	1 update per frame	2 updates per frame
"medium"	2 updates per frame	4 updates per frame
"short"	3 updates per frame	5 updates per frame

5.2.1.4.5 TPC procedure in the network

In SSdT, a non-primary cell can switch off its DPDCH output (i.e. no transmissions).

The cell manages two downlink transmission power levels, P1, and P2. Power level P1 is used for downlink DPCCH transmission power level and this level is updated as the same way specified in 5.2.1.2 or 5.2.1.3 in compressed mode regardless of the selected state (primary or non-primary). The actual transmission power of TFCI, TPC and pilot fields of DPCCH is set by adding P1 and the offsets PO1, PO2 and PO3, respectively, as specified in 5.2.1.1. P2 is used for downlink DPDCH transmission power level and this level is set to P1 if the cell is selected as primary, otherwise P2 is switched off. The cell updates P1 first and P2 next, and then the two power settings P1 and P2 are maintained within the power control dynamic range. Table 6 summarizes the updating method of P1 and P2.

Table 6: Updating of P1 and P2

State of cell	P1 (DPCCH)	P2 (DPDCH)
non primary	Updated by the same way as specified in 5.2.1.2 or 5.2.1.3 in compressed mode	Switched off
primary		= P1

5.2.2 PDSCH

The PDSCH power control can be based on the following solutions, which are selectable, by the network:

- Inner-loop power control based on the power control commands sent by the UE on the uplink DPCCH.
- Slow power control.

UTRAN may use the SSdT signalling to determine what power offset to use for PDSCH with respect to the associated downlink DCH when more than one cell may be in the active set.

The PDSCH power offset value to be used with respect to the associated DCH depends on whether the cell transmitting PDSCH is determined to be a primary one or not. The power offset values for both cases, a cell being primary (*primary_DSCH_pow*) and a cell being non-primary (*non-primary_DSCH_pow*), are given by higher layers.

The SSdT commands sent by the UE are averaged in UTRAN side over one or more frames. The averaging window length parameter as the number of frames to average over, *SSdT_aveg_window*, and the parameter for the required number of received primary SSdT commands, *SSdT_primary_commands*, during the averaging window for declaring primary status are given by higher layers. If the number of primary commands received during the averaging window is less than the parameter *SSdT_primary_commands*, then an offset given for the non-primary case is used.

7.2 WG2

The possibility to use SSdT signalling without SSdT transmission in the downlink needs small modification in the SSdT information elements in RRC specification. This means adding one additional parameter in addition to the ID lengths currently covered in RRC specification (25.331 in TSG RAN WG2). The SSdT code word parameters would remain unchanged.

The following parameter list needs to be extended in 25.331 with the parameter SSdT transmission in the downlink (on/off). Further details on the RRC parameter change is left for WG2 to elaborate.

10.3.6.67 SSdT information

NOTE: Only for FDD.

This information element indicates the status (e.g. initiated/terminated) of the Site Selection.

Diversity Transmit power control (SSdT). It is used to change the SSdT status. The parameter 'code word set' indicates how cell identities are coded (using many bits or few, values are long, medium, or short).

Information name	Element/Group	Need	Multi	Type and reference	Semantics description
S field		MP		Integer (1, 2)	in bits
Code Word Set		MP		Enumerated (long, medium, short, SSdT off)	

7.3 WG3

For the WG3 aspects the needed changes are covered in [2] for the Iub and Iur specifications.

7.4 WG4

No impacts foreseen at this point for Release –4.

8 Backward Compatibility

The proposal is backwards compatible with Release –99 UEs. Release –99 terminals can operate in Release 4 network and respectively Release 4 terminals may operate with Release –99 Node Bs where this feature is not available This is simple to justify as the proposal uses existing SSdT signalling in the uplink which is used to improve the performance in setting the power offset for DSCH frame for particular UE. The form of the downlink transmission in case of DCH (is SSdT applied or not), which is not causing any issues between UEs and occurs in Release –99 as well between different UEs as well.

Annex A (informative): Change history

Change history							
Date	TSG #	TSG Doc.	CR	Rev	Subject/Comment	Old	New
15/12/00	RAN_10	RP-000549	-	-	Approved at TSG RAN #10 and placed under Change Control	-	4.0.0