

TSG-RAN Working Group 1 meeting #19
Las Vegas, USA
Feb. 27 – March 2, 2001

TSGR1#19(01)0299

Agenda item: AH 99
Source: InterDigital Communications Corporation
Title: Corrections to SCH section.
Document for: Decision

This CR:

1. Corrects Figure 14 describing the synchronisation channel scheme, and clarifies the text in the section 5.3.4.
2. Adds indexing is to t_{offset} to indicate that it is cell dependent.
3. Clarifies the text in the section 6.2.1

CR-Formv3	
CHANGE REQUEST	
⚡ 25.221 CR 033 ⚡ rev 1 ⚡ Current version: 3.5.0 ⚡	

For **HELP** on using this form, see bottom of this page or look at the pop-up text over the ⚡ symbols.

Proposed change affects: ⚡ (U)SIM ME/UE Radio Access Network Core Network

Title:	⚡ Correction to SCH section	
Source:	⚡ InterDigital Comm. Corp.	
Work item code:	⚡	Date: ⚡ February 26, 2001
Category:	⚡ F	Release: ⚡ R99
	Use one of the following categories: F (essential correction) A (corresponds to a correction in an earlier release) B (Addition of feature), C (Functional modification of feature) D (Editorial modification) Detailed explanations of the above categories can be found in 3GPP TR 21.900.	Use one of the following releases: 2 (GSM Phase 2) R96 (Release 1996) R97 (Release 1997) R98 (Release 1998) R99 (Release 1999) REL-4 (Release 4) REL-5 (Release 5)

Reason for change:	⚡ The description of SCH codes power distribution is misleading
Summary of change:	⚡ Fig. 14 is redrawn to show correct power distribution of SCH codes. Indexing is added to t_{offset} to indicate that it is cell dependent.
Consequences if not approved:	⚡ Misleading information on SCH power distribution in the specification

Clauses affected:	⚡ 5.3.4, 6.2.1	
Other specs affected:	<input type="checkbox"/> Other core specifications <input type="checkbox"/> Test specifications <input type="checkbox"/> O&M Specifications	⚡
Other comments:	⚡	

How to create CRs using this form:

Comprehensive information and tips about how to create CRs can be found at: http://www.3gpp.org/3G_Specs/CRs.htm. Below is a brief summary:

- 1) Fill out the above form. The symbols above marked ⚡ contain pop-up help information about the field that they are closest to.
- 2) Obtain the latest version for the release of the specification to which the change is proposed. Use the MS Word "revision marks" feature (also known as "track changes") when making the changes. All 3GPP specifications can be downloaded from the 3GPP server under <ftp://www.3gpp.org/specs/> For the latest

version, look for the directory name with the latest date e.g. 2000-09 contains the specifications resulting from the September 2000 TSG meetings.

- 3) With "track changes" disabled, paste the entire CR form (use CTRL-A to select it) into the specification just in front of the clause containing the first piece of changed text. Delete those parts of the specification which are not relevant to the change request.

5.3.4 The synchronisation channel (SCH)

In TDD mode code group of a cell can be derived from the synchronisation channel. In order not to limit the uplink/downlink asymmetry the SCH is mapped on one or two downlink slots per frame only.

There are two cases of SCH and P-CCPCH allocation as follows:

Case 1) SCH and P-CCPCH allocated in TS#k, $k=0 \dots 14$

Case 2) SCH allocated in two TS: TS#k and TS#k+8, $k=0 \dots 6$; P-CCPCH allocated in TS#k.

The position of SCH (value of k) in frame can change on a long term basis in any case.

Due to this SCH scheme, the position of P-CCPCH is known from the SCH.

Figure 14 is an example for transmission of SCH, $k=0$, of Case 2.

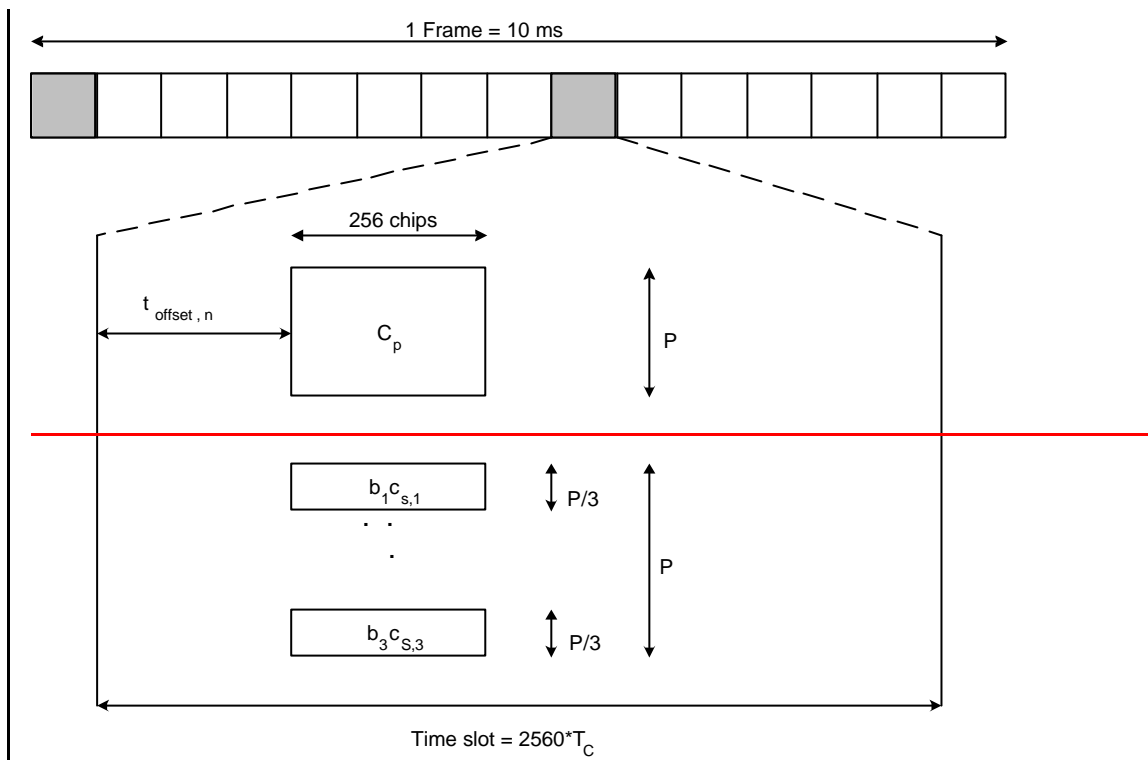

$C_{s,i} ? \{ C_0, C_1, C_3, C_4, C_5, C_6, C_8, C_{10}, C_{12}, C_{13}, C_{14}, C_{15} \}, i=1,2,3; \text{ see [8]}$

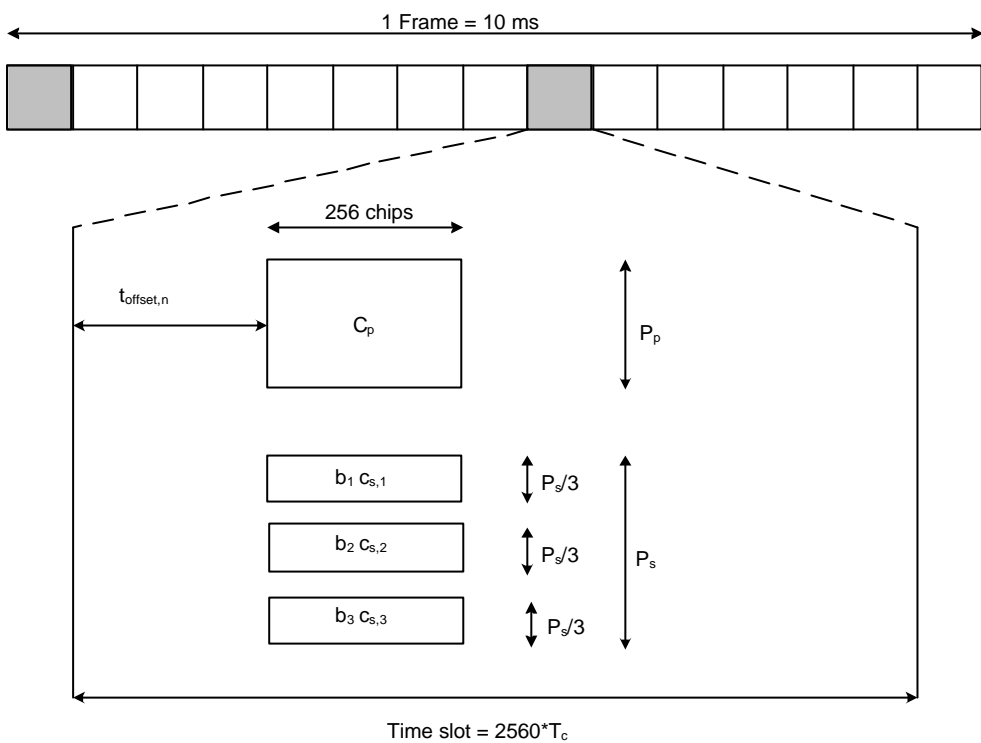

$b_i \in \{1, 2, 3\}$, $C_{s,i} \in \{C_0, C_1, C_3, C_4, C_5, C_6, C_8, C_{10}, C_{12}, C_{13}, C_{14}, C_{15}\}$, $i=1,2,3$; see [8]

Figure 14: Scheme for Synchronisation channel SCH consisting of one primary sequence C_p and 3 parallel secondary sequences $C_{s,i}$ in slot k and $k+8$ (example for $k=0$ in Case 2)

As depicted in figure 14, the SCH consists of a primary and three secondary code sequences with each 256 chips length long. The primary and secondary code sequences are defined in [8] clause 7 'Synchronisation codes'.

Due to mobile to mobile interference, it is mandatory for public TDD systems to keep synchronisation between base stations. As a consequence of this, a capture effect concerning SCH can arise. The time offset $t_{\text{offset},n}$ enables the system to overcome the capture effect.

The time offset $t_{\text{offset},n}$ is one of 32 values, depending on the cell parameter, thus on the code group of the cell, n , cf. 'table 6 Mapping scheme for Cell Parameters, Code Groups, Scrambling Codes, Midambles and t_{offset} ' in [8]. Note that the cell parameter will change from frame to frame, cf. 'Table 7 Alignment of cell parameter cycling and system frame number' in [8], but the cell will belong to only one code group and thus have one time offset $t_{\text{offset},n}$. The exact value for $t_{\text{offset},n}$, regarding column 'Associated t_{offset} ' in table 6 in [8] is given by:

$$t_{\text{offset},n} = \begin{cases} n \cdot 48 T_c & n \in \{0, \dots, 15\} \\ n \cdot 16 T_c & n \in \{16, \dots, 31\} \end{cases} ; \quad t_{\text{offset},n} = \begin{cases} n \cdot T_c \cdot \frac{2560 - 96 - 256}{31} & n \in \{0, \dots, 15\} \\ n \cdot 71 T_c & n \in \{16, \dots, 31\} \end{cases}$$

Please note that $\lceil x \rceil$ denotes the largest integer number less or equal to x and that T_c denotes the chip duration.

5.3.5 Physical Uplink Shared Channel (PUSCH)

For Physical Uplink Shared Channel (PUSCH) the burst structure of DPCH as described in subclause 5.2 shall be used. User specific physical layer parameters like power control, timing advance or directive antenna settings are derived from the associated channel (FACH or DCH). PUSCH provides the possibility for transmission of TFCI in uplink.

5.3.6 Physical Downlink Shared Channel (PDSCH)

For Physical Downlink Shared Channel (PDSCH) the burst structure of DPCH as described in subclause 5.2 shall be used. User specific physical layer parameters like power control or directive antenna settings are derived from the associated channel (FACH or DCH). PDSCH provides the possibility for transmission of TFCI in downlink.

To indicate to the UE that there is data to decode on the DSCH, three signalling methods are available:

- 1) using the TFCI field of the associated channel or PDSCH;
- 2) using on the DSCH user specific midamble derived from the set of midambles used for that cell;
- 3) using higher layer signalling.

When the midamble based method is used, the UE shall decode the PDSCH if the PDSCH was transmitted with the midamble assigned to the UE by UTRAN, see 5.5.1.1.2. For this method no other physical channels may use the same time slot as the PDSCH and only one UE may share the PDSCH time slot at the same time.

5.3.7 The Paging Indicator Channel (PICH)

The Paging Indicator Channel (PICH) is a physical channel used to carry the paging indicators.

Figure 15 depicts the structure of a PICH burst and the numbering of the bits within the burst. The same burst type is used for the PICH in every cell. N_{PIB} bits in a normal burst of type 1 or 2 are used to carry the paging indicators, where N_{PIB} depends on the burst type: $N_{PIB}=240$ for burst type 1 and $N_{PIB}=272$ for burst type 2. The bits $b_{N_{PIB}}, \dots, b_{N_{PIB}+3}$ adjacent to the midamble are reserved for possible future use. They shall be set to 0 and transmitted with the same power as the paging indicator carrying bits.

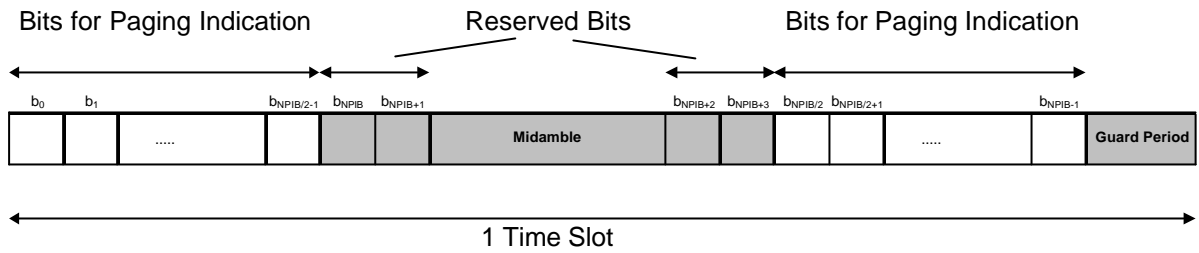

Figure 15: Transmission and numbering of paging indicator carrying bits in a PICH burst

In each time slot, N_{PI} paging indicators are transmitted, using $L_{PI}=2$, $L_{PI}=4$ or $L_{PI}=8$ symbols. L_{PI} is called the paging indicator length. The number of paging indicators N_{PI} per time slot is given by the paging indicator length and the burst type, which are both known by higher layer signalling. In table 8 this number is shown for the different possibilities of burst types and paging indicator lengths.

Table 8: Number N_{PI} of paging indicators per time slot for the different burst types and paging indicator lengths L_{PI}

	$L_{PI}=2$	$L_{PI}=4$	$L_{PI}=8$
Burst Type 1	$N_{PI}=60$	$N_{PI}=30$	$N_{PI}=15$
Burst Type 2	$N_{PI}=68$	$N_{PI}=34$	$N_{PI}=17$

As shown in figure 16, the paging indicators of N_{PICH} consecutive frames form a PICH block, N_{PICH} is configured by higher layers. Thus, $N_P = N_{PICH} \cdot N_{PI}$ paging indicators are transmitted in each PICH block.

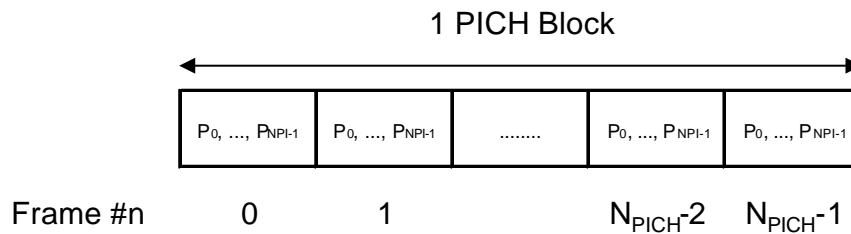

Figure 16: Structure of a PICH block

The value PI ($PI = 0, \dots, N_P - 1$) calculated by higher layers for use for a certain UE, see [15], is associated to the paging indicator P_q in the n th frame of one PICH block, where q is given by

$$q = PI \bmod N_{PI}$$

and n is given by

$$n = PI \text{ div } N_{PI}$$

The PI bitmap in the PCH data frames over l_{ub} contains indication values for all possible higher layer PI values, see [16]. Each bit in the bitmap indicates if the paging indicator P_q associated with that particular PI shall be set to 0 or 1.

Hence, the calculation in the formulas above is to be performed in Node B to make the association between PI and P_q .

The paging indicator P_q in one time slot is mapped to the bits $\{b_{L_{PI} \cdot q}, \dots, b_{L_{PI} \cdot q + L_{PI} - 1}, b_{N_{PIB}/2 + L_{PI} \cdot q}, \dots, b_{N_{PIB}/2 + L_{PI} \cdot q + L_{PI} - 1}\}$ within this time slot, as exemplary shown in figure 17. Thus, half of the L_{PI} symbols used for each paging indicator are transmitted in the first data part, and the other half of the L_{PI} symbols are transmitted in the second data part.

The coding of the paging indicator P_q is given in [7].

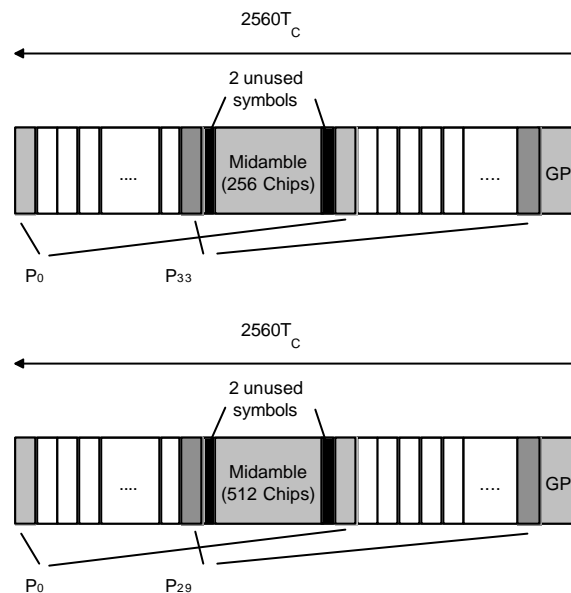

Figure 17: Example of mapping of paging indicators on PICH bits for $L_{PI}=4$

5.4 Transmit Diversity for DL Physical Channels

Table 9 summarizes the different transmit diversity schemes for different downlink physical channel types that are described in [9].

Table 9: Application of Tx diversity schemes on downlink physical channel types
"X" – can be applied, "-" – must not be applied

Physical channel type	Open loop Tx Diversity		Closed loop Tx Diversity
	TSTD	Block STTD	
P-CCPCH	-	X	-
SCH	X	-	-
DPCH	-	-	X

5.5 Beacon characteristics of physical channels

For the purpose of measurements, physical channels at particular locations (time slot, code) shall have particular physical characteristics, called beacon characteristics. Physical channels with beacon characteristics are called beacon channels. The locations of the beacon channels are called beacon locations. The ensemble of beacon channels shall provide the beacon function, i.e. a reference power level at the beacon locations, regularly existing in each radio frame. Thus, beacon channels must be present in each radio frame.

5.5.1 Location of beacon channels

The beacon locations are determined by the SCH and depend on the SCH allocation case, see 5.3.4:

- Case 1) The beacon function shall be provided by the physical channels that are allocated to channelisation code $c_{Q?16}^{(k?1)}$ and to TS#k, k=0...14.
- Case 2) The beacon function shall be provided by the physical channels that are allocated to channelisation code $c_{Q?16}^{(k?1)}$ and to TS#k and TS#k+8, k=0...6.

Note that by this definition the P-CCPCH always has beacon characteristics.

5.5.2 Physical characteristics of beacon channels

The beacon channels shall have the following physical characteristics. They:

- are transmitted with reference power;
- are transmitted without beamforming;
- use burst type 1;
- use midamble $m^{(1)}$ and $m^{(2)}$ exclusively in this time slot; and
- midambles $m^{(9)}$ and $m^{(10)}$ are always left unused in this time slot, if 16 midambles are allowed in that cell.

Note that in the time slot where the P-CCPCH is transmitted only the midambles $m^{(1)}$ to $m^{(8)}$ shall be used, see 5.6.1. Thus, midambles $m^{(9)}$ and $m^{(10)}$ are always left unused in this time slot.

The reference power corresponds to the sum of the power allocated to both midambles $m^{(1)}$ and $m^{(2)}$. Two possibilities exist:

- If no Block STTD antenna diversity is applied to P-CCPCH, all the reference power of any beacon channel is allocated to $m^{(1)}$.
- If Block STTD antenna diversity is applied to P-CCPCH, for any beacon channel midambles $m^{(1)}$ and $m^{(2)}$ are each allocated half of the reference power. Midamble $m^{(1)}$ is used for the first antenna and $m^{(2)}$ is used for the diversity antenna. Block STTD encoding is used for the data in P-CCPCH, see [9]; for all other beacon channels identical data sequences are transmitted on both antennas.

5.6 Midamble Allocation for Physical Channels

Midambles are part of the physical channel configuration which is performed by higher layers. Three different midamble allocation schemes exist:

- UE specific midamble allocation: A UE specific midamble for DL or UL is explicitly assigned by higher layers.
- Default midamble allocation: The midamble for DL or UL is allocated by layer 1 depending on the associated channelisation code.
- Common midamble allocation: The midamble for the DL is allocated by layer 1 depending on the number of channelisation codes currently being present in the DL time slot.

If a midamble is not explicitly assigned and the use of the common midamble allocation scheme is not signalled by higher layers, the midamble shall be

allocated by layer 1, based on the default midamble allocation scheme. This default midamble allocation scheme is given by a fixed association between midambles and channelisation codes, see clause A.3, and shall be applied individually to all channelisation codes within one time slot. Different associations apply for different burst types and cell configurations with respect to the maximum number of midambles.

5.6.1 Midamble Allocation for DL Physical Channels

Beacon channels shall always use the reserved midambles $m^{(1)}$ and $m^{(2)}$, see 5.5. For DL physical channels that are located in the same time slot as the P-CCPCH, midambles shall be allocated based on the default midamble allocation scheme, using the association for burst type 1 and $K=8$ midambles. For all other DL physical channels, the midamble is explicitly assigned by higher layers or allocated by layer 1.

5.6.1.1 Midamble Allocation by signalling from higher layers

UE specific midambles may be signalled by higher layers to UE's as a part of the physical channel configuration, if:

- multiple UEs use the physical channels in one DL time slot; and
- beamforming is applied to all of these DL physical channels; and
- no closed loop TxDiversity is applied to any of these DL physical channels;

or

- PDSCH physical layer signalling based on the midamble is used.

5.6.1.2 Midamble Allocation by layer 1

5.6.1.2.1 Default midamble

If a midamble is not explicitly assigned and the use of the common midamble allocation scheme is not signalled by higher layers, the UE shall derive the midamble from the associated channelisation code and shall use an individual midamble for each channelisation code. For each association between midambles and channelisation codes in annex A.3, there is one primary channelisation code associated to each midamble. A set of secondary channelisation codes is associated to each primary channelisation code. All the secondary channelisation codes within a set use the same midamble as the primary channelisation code to which they are associated.

Higher layers shall allocate the channelisation codes in a particular order. Primary channelisation codes shall be allocated prior to associated secondary channelisation codes. If midambles are reserved for the beacon channels, all primary and secondary channelisation codes that are associated with the reserved midambles shall not be used.

Primary and its associated secondary channelisation codes shall not be allocated to different UE's.

In the case that secondary channelisation codes are used, secondary channelisation codes of one set shall be allocated in ascending order, with respect to their numbering.

5.6.1.2.2 Common Midamble

The use of the common midamble allocation scheme is signalled to the UE by higher layers as a part of the physical channel configuration. A common midamble may be assigned by layer 1 to all physical channels in one DL time slot, if:

- a single UE uses all physical channels in one DL time slot (as in the case of high rate service);

or

- multiple UEs use the physical channels in one DL time slot; and
- no beamforming is applied to any of these DL physical channels; and
- no closed loop Tx Diversity is applied to any of these DL physical channels; and
- midambles are not used for PDSCH physical layer signalling.

The number of channelisation codes currently employed in the DL time slot is associated with the use of a particular common midamble. Different associations apply for different burst types and cell configurations with respect to the maximum number of midambles, see annex B.

5.6.2 Midamble Allocation for UL Physical Channels

If the midamble is explicitly assigned by higher layers, an individual midamble shall be assigned to all UE's in one UL time slot.

If no midamble is explicitly assigned by higher layers, the UE shall derive the midamble from the channelisation code that is used for the data part (except for TFCI/TPC) of the burst. The associations between midamble and channelisation code are the same as for DL physical channels.

5.7 Midamble Transmit Power

There shall be no offset between the sum of the powers allocated to all midambles in a timeslot and the sum of the powers allocated to the data symbol fields. The transmit power within a timeslot is hence constant.

The midamble transmit power of beacon channels is equal to the reference power. If Block STTD is used for the P-CCPCH, the reference power is equally divided between the midambles $m^{(1)}$ and $m^{(2)}$.

The midamble transmit power of all other physical channels depends on the midamble allocation scheme used. The following rules apply

- In case of Default Midamble Allocation, every midamble is transmitted with the same power as the associated codes.
- In case of Common Midamble Allocation in the downlink, the transmit power of this common midamble is such that there is no power offset between the data parts and the midamble part of the overall transmit signal within one time slot.

- In case of UE Specific Midamble Allocation, the transmit power of the UE specific midamble is such that there is no power offset between the data parts and the midamble part of every user within one time slot.

The following figure depicts the midamble powers for the different channel types and midamble allocation schemes. For the UE Specific Midamble Allocation, as an example, code 1 and code 2 are both assigned to UE 1, whereas to UE m is assigned only the code n.

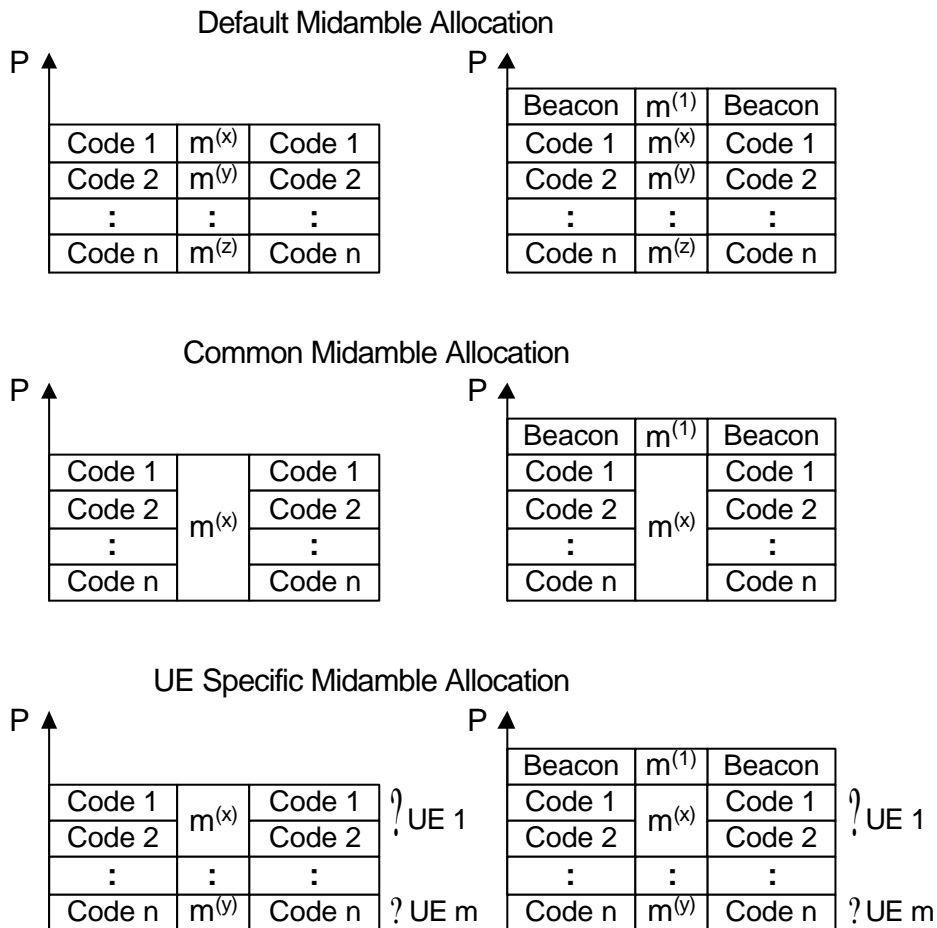

Figure 18: Midamble powers for the different midamble allocation schemes

6 Mapping of transport channels to physical channels

This clause describes the way in which transport channels are mapped onto physical resources, see figure 19.

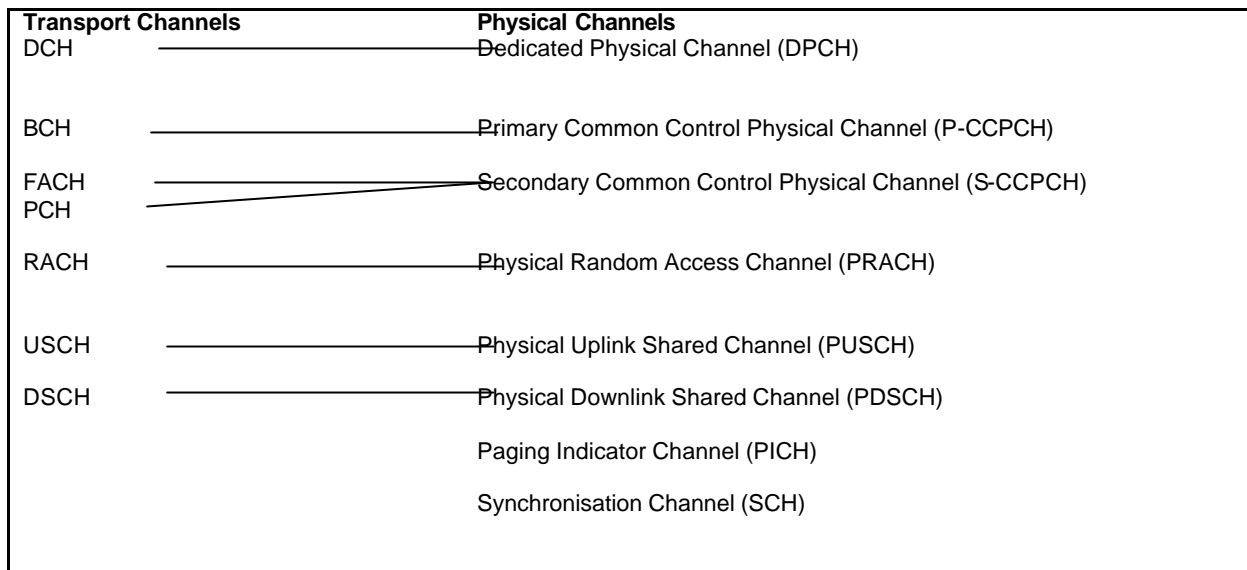

Figure 19: Transport channel to physical channel mapping

6.1 Dedicated Transport Channels

A dedicated transport channel is mapped onto one or more physical channels. An interleaving period is associated with each allocation. The frame is subdivided into slots that are available for uplink and downlink information transfer. The mapping of transport blocks on physical channels is described in TS 25.222 ("multiplexing and channel coding").

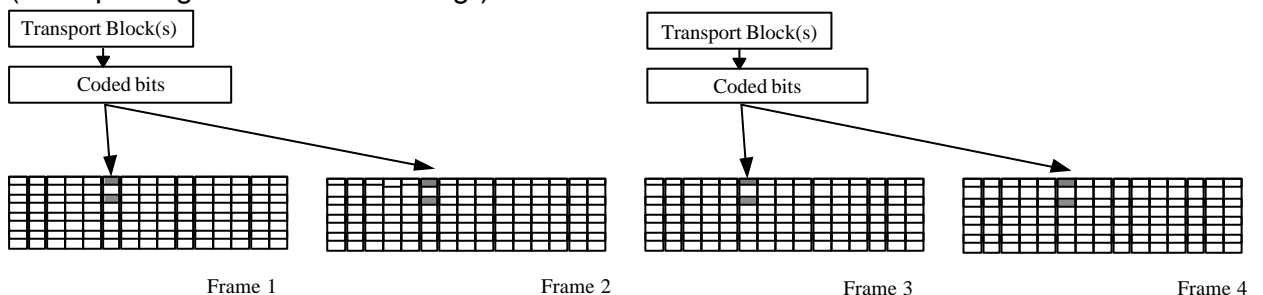

Figure 20: Mapping of Transport Blocks onto the physical bearer

For NRT packet data services, shared channels (USCH and DSCH) can be used to allow efficient allocations for a short period of time.

6.2 Common Transport Channels

6.2.1 The Broadcast Channel (BCH)

The BCH is mapped onto the P-CCPCH. The secondary SCH codes indicates in which timeslot a mobile can find the P-CCPCH containing BCH.

