

Stockholm, Sweden, November 21st – 24th, 2000**Agenda item:****Source:** Samsung**Title:** Downlink Tx Diversity Schemes for 1.28Mcps UTRA TDD**Document for:** Discussion and approval**Abstract**

Downlink transmit diversity schemes are proposed for the 1.28Mcps UTRA TDD. In the proposed TSTD schemes, two spatially separated antennas are alternately used at the base station to transmit each consecutive sub-frame of the downlink physical channels. The proposed TSTD scheme takes advantage of the frame structure of the 1.28Mcps UTRA TDD, where the frame structure makes TSTD transmission possible with a single power amplifier.

Introduction

The performance of a mobile communication system depends largely on how well the system is designed to overcome the time varying characteristics of the communication channel. One way of improving the performance in time varying channel environment is to use diversity technology. TSTD (Time Switched Transmit Diversity), TxAA (Transmit Antenna Array), and STTD (Space Time Transmit Diversity) are three of the methods that use (time and) space diversity technology. Each of these three methods has its own advantages and disadvantages. The advantages of TSTD are that it is quite simple to implement and the receiver structure requires little changes to receive the TSTD transmitted signal. Even though the performance of TSTD may not be the best among other transmit diversity schemes mentioned above, at worst the performance of TSTD is on par with the single antenna case. Furthermore, taking advantage of the frame structure of 1.28Mcps UTRA TDD, the base station can use TSTD with only a single power amplifier, by alternately switching the power amplifier between the two antennas. Since the power amplifier is the most expensive part of the base station system, this feature makes TSTD a quite attractive technique as long as the system cost is concerned.

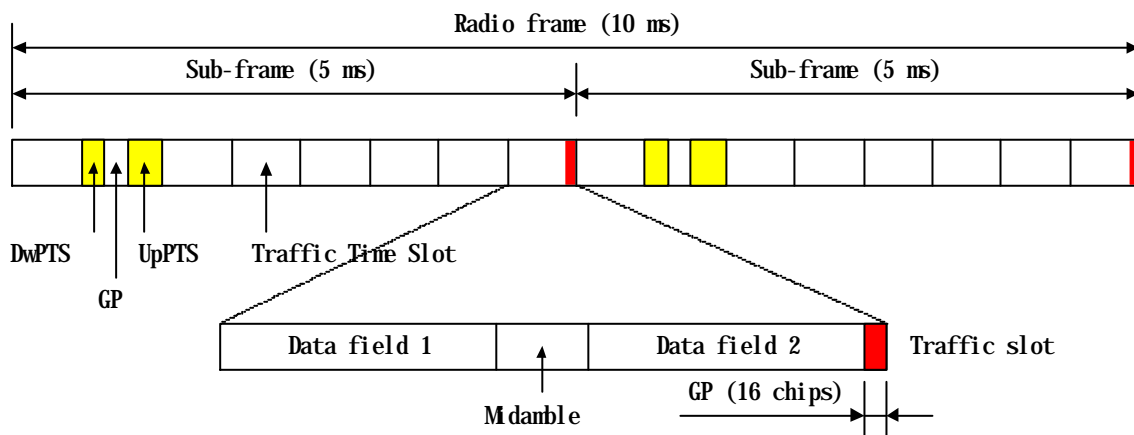

Figure 1. The frame and sub-frame structure of 1.28Mcps TDD mode.

Frame Structure of 1.28Mcps TDD mode

Figure 1 shows the frame structure of 1.28Mcps UTRA TDD. As shown in the figure, a 10ms radio frame consists of two 5ms sub-frames, each of which in turn consists of 7 traffic timeslots, DwPTS (Downlink Pilot Time Slot), UpPTS (Uplink Pilot Time Slot) and a Guard Period. And each of the traffic timeslots consists of

two data fields, a midamble part, and a 16 chip long guard period at the end of the timeslot. Thus, there is a 16 chip long guard period of 12.5 μ sec at the end of each sub-frame (marked in red in figure 1).

TSTD Transmission

In 1.28Mcps UTRA TDD, we can take advantage of the 12.5 μ sec guard period for TSTD transmission. Figure 2 shows an example of the structure of the proposed TSTD transmitter of 1.28Mcps UTRA TDD. As shown in the figure, channel coded and interleaved data is QPSK modulated, and then spread and scrambled before it is time multiplexed with the midamble sequence. The time multiplexed signal is then transformed into analog signal by pulse shaping filter, where it is then modulated to the carrier frequency. The modulated signal is then amplified to an appropriate power level by using power amplifier. For TSTD transmission, two spatially separated antennas alternate with each other to transmit the signal every sub-frame. During the 12.5 μ sec period at the end of each sub-frame, the power amplifier is switched from one antenna to the other of the two antennas every 5 ms sub-frame. Thus, each of the two antennas transmits the signal 100 times a second, for 5 ms each time, and the power amplifier is switched from antenna 1 to antenna 2 or from antenna 2 to antenna 1 200 times a second. Because of the 12.5 μ sec, TSTD transmission is possible with only one power amplifier as shown in figure 2. The transmission pattern of the two TSTD antennas is shown in figure 3. Note that TSTD transmission is identical to the transmission of the signal by a single antenna without Tx diversity, except for the switching operation between the two antennas.

A summary of the proposed scheme is as follows.

- /// The proposed scheme takes advantage of the sub-frame structure of 1.28Mcps TDD mode.
- /// Negligible additional hardware cost for base station (no additional power amplifier).
- /// There is little impact on UE receiver structure.
- /// TSTD requires minimal higher layer signalling. The higher layer only need to inform the UE that TSTD scheme is used so that UE can use appropriate power control algorithm.

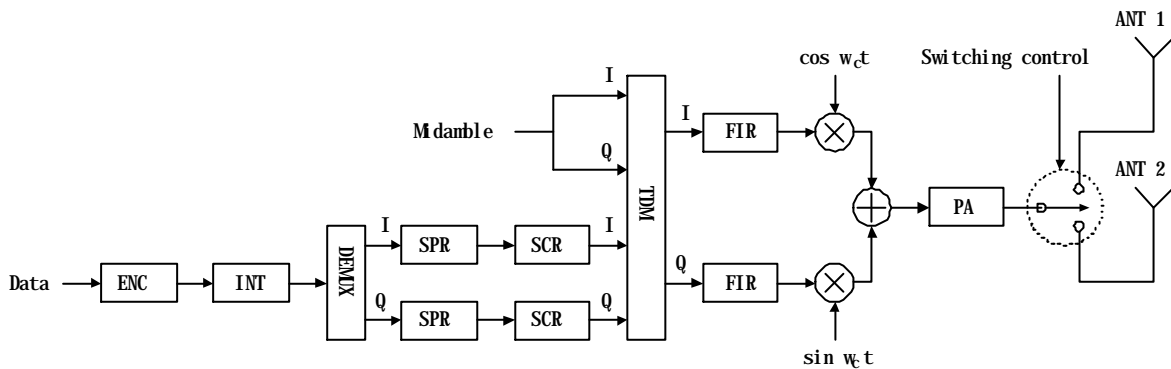

Figure 2. Transmit air-interface protocol of TSTD base-station

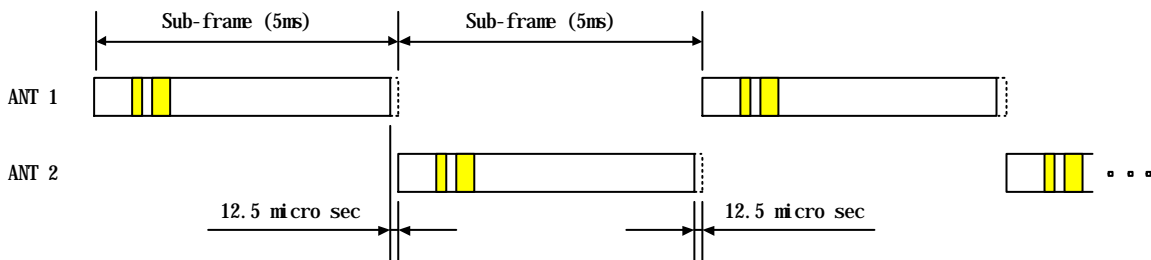

Figure 3. TSTD switching pattern utilizing sub-frame structure

Tx Diversity and Beamforming

Depending on the capability of the base station and the characteristics of the physical channels, many different combinations of TSTD, STTD, and beamforming are possible. For DwPCH, STTD cannot be used due to its nature. For P-CCPCH, both of the STTD and TSTD can be used but beamforming cannot be used because P-CCPCH carries the broadcast channel BCH. On the other hand, beamforming as well as Tx diversity schemes such as STTD or TSTD can be used for DPCH. Table 1 summarizes the possible cases of the combination of these technologies for three physical channels: DwPCH, P-CCPCH, DPCH.

Table 1. Tx Diversity and beamforming

	DwPCH	P-CCPCH	DPCH
Case 1	None	None	None or BF
Case 2	None or TSTD	STTD	BF
Case 3	TSTD	TSTD	TSTD or BF

When the base station is equipped with an array antenna, TSTD can be used with beamforming (case 2 or case 3); beamforming can be used for the transmission of dedicated channels, but common channels such as P-CCPCH or S-CCPCH can be transmitted using TSTD.

Uplink Synchronization with TSTD

If TSTD is used, the channel between the UE and antenna 1 and 2 are different, which may cause a different propagation delay between the odd numbered sub-frame and even numbered sub-frames. However, as shown in [1], when two separate antennas are used, more than 99% of the difference of the propagation delays between the two antennas is less than 12nsec, where 1 chip corresponds to 781.25 nsec and 1/8 chip corresponds to 97.7 nsec. Thus, even though the channel environment of the two antennas are different, the difference does not affect the uplink synchronization procedure of 1.28Mcps UTRA TDD.

Simulation Result

Although the performance of DPCH can be improved by using beamforming, beamforming is an optional feature and not every base station is expected to be equipped with beamforming capability because of its complexity. In that case, DPCH can be transmitted using TSTD.

Unlike common physical channels, DPCH is closed loop power controlled and the closed loop power control algorithm of UE needs to be changed when TSTD is used. However, the only required change in power control algorithm is how to produce the power control command, and the basic flow of the power control procedure remains the same. Since it is assumed that the distance between antenna 1 and antenna 2 is far enough for non coherent transmission, the channel environment between the UE and antenna 1 is different from that between UE and antenna 2. Thus, because of the TSTD transmission pattern shown in figure 3, the measurement of the received signal by UE in sub-frame n and sub-frame $n+1$ corresponds to different antennas and channels. This feature is considered in the new power control algorithm for TSTD. The new power control algorithm uses a linear combination of the two measurements of the received signal power in two consecutive sub-frames to update transmit power level. The performance of the new power control algorithm varies depending on the linear combination coefficients. Let w_1 and w_2 be the linear combination coefficient of the first (older of the two) and second (more recent) measurements, respectively. Two extreme cases of the linear combination coefficients are when $w_1 = 1$, and $w_2 = 0$, and $w_1 = 0$ and $w_2 = 1$. In the first case, the Rx power measurement only in sub-frame n is used to update the DL transmit power in sub-frame $n+2$. Thus Rx power measurement from antenna 1 is used to update the Tx power of antenna 1, and the Rx power measurement from antenna 2 is used to update the Tx power of antenna 2. In the second case, the Rx power measurement from antenna 1 is used to update the Tx power of antenna 2, and vice versa. In general, $w_1 > 0$ and $w_2 > 0$ can be used as the linear combination coefficients, where $w_1 + w_2 = 1$. In the

following, simulation results are presented to show the performance of TSTD with closed loop power control in comparison with a single antenna case. The simulation parameters used are as follows.

Target FER	1%
Channel	1-path fading
Service	12.2kbps voice
Channel coding	1/3 convolutional coding
Channel estimation	Ideal channel estimation

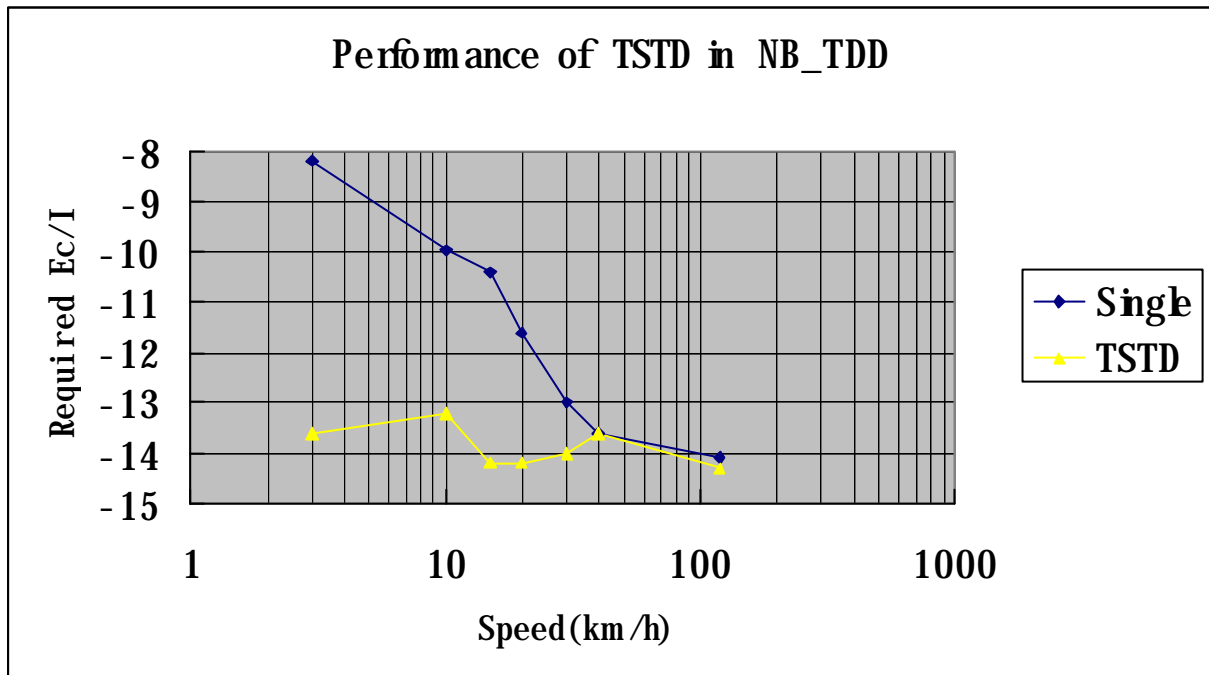

Figure 5. The performance of TSTD with DL closed loop power control

Figure 5 shows the simulation result.

When no transmit diversity scheme is used (marked "Single", meaning single antenna), the required E_c/I_{or} for the target FER of 1% decreases as the speed increases. This is due to the interleaving and convolutional coding gain.

When TSTD is used, the new power control algorithm is used. Figure 5 shows the results when two consecutive Rx power measurements are combined to produce the power control command (marked "TSTD"). As shown in the figure, the new power control algorithm has the better performance for all frequency ranges; more than 5dB performance gain at low speed, and about the same performance above 40km/h. Since the channel environments from the two antennas to the UE are different, when TSTD is used, the probability of losing both of the two consecutive sub-frames is lower than single antenna case, and hence the probability of recovering the data is higher, which leads to smaller required transmit power for the base station at low speed. On the other hand, at high speed, because of the interleaving and coding gain, the effect of transmit diversity gain is relatively small and thus the overall performance of TSTD scheme is about the same as the single antenna case.

Note: I_{or} is the total transmitted power density by a BTS. Since the base station has a fixed amount of power determined by the BTS power amplifier size, it is the average transmit (often called allocated) power by the BTS to the MS that determines the user capacity of the forward link. This fraction of the allocated power is called average traffic channel E_c/I_{or} and is inversely proportional to the forward link capacity [2].

Conclusion

We propose a TSTD scheme for downlink physical channels of 1.28Mcps UTRA TDD. The proposed scheme utilizes the sub-frame structure of 1.28Mcps UTRA TDD. The proposed scheme obtains a Tx diversity gain with little extra hardware complexity of RF switch and additional antenna of the base station, and the receiver structure of the UE requires minor change for the generation of DL TPC command.

Some simulation results are included to show the performance gain the TSTD scheme for Dedicated channel with closed loop power control.

The following is the proposed text for the working CRs for TS 25.221 and TS 25.224.

Reference

[1] SMG2 UMTS-L1 317/98, "Complexity requirements of OTD and TSTD", Motorola.

[2] Physical Layer Aspects of UTRA High Speed Downlink Packet Access, TSGR1#16(00)1306, Pusan, Korea, Oct. 10 – 13, 2000.

----- Beginning of the proposed changes of the working CR for 25.221 -----

6.4 Transmit Diversity for DL Physical Channels

Table X1 summarizes the different transmit diversity schemes for different downlink physical channel types in 1.28Mcps TDD that are described in [9].

Table X1: Application of Tx diversity schemes on downlink physical channel types in 1.28Mcps UTRA TDD

"X" – can be applied, "-" – must not be applied

Physical channel type	Open loop Tx Diversity		Closed loop Tx Diversity
	TSTD	Block STTD	
P-CCPCH	-	X	-
DwPCH	X	-	-
FPACH	-	-	X
DPCH	-	-	X

Physical channel type	Open loop Tx Diversity		Closed loop Tx Diversity
	TSTD	Block STTD	
P-CCPCH	X	X	=
DwPCH	X	=	=
DPCH	X	=	X

~~Note: Closed loop transmit diversity for the FPACH makes use of the UpPCH~~

----- End of the proposed changes of the working CR for 25.221 -----

----- Beginning of text proposal for working CR for 25.224 -----

5.5 Downlink Transmit Diversity for 1.28 Mcps UTRA TDD

5.5.1 Transmit Diversity for DPCH

Closed loop Transmit Diversity or Time Switched Transmit Diversity (TSTD) may be employed as transmit diversity scheme for downlink DPCH.

5.5.1.1 TSTD for DPCH

TSTD can be employed as transmit diversity scheme for downlink DPCH. The transmitter structure of the TSTD transmitter is shown in figure [F1]. Channel coding, rate matching, interleaving, bit-to-symbol mapping, spreading, and scrambling are performed as in the non-diversity mode. Then the data is time multiplexed with the midamble sequence. Then, after pulse shaping, modulation and amplification, DPCH is transmitted from antenna 1 and antenna 2 alternately every sub-frame. Figure [F2] shows the antenna switching pattern for the transmission of DPCH.

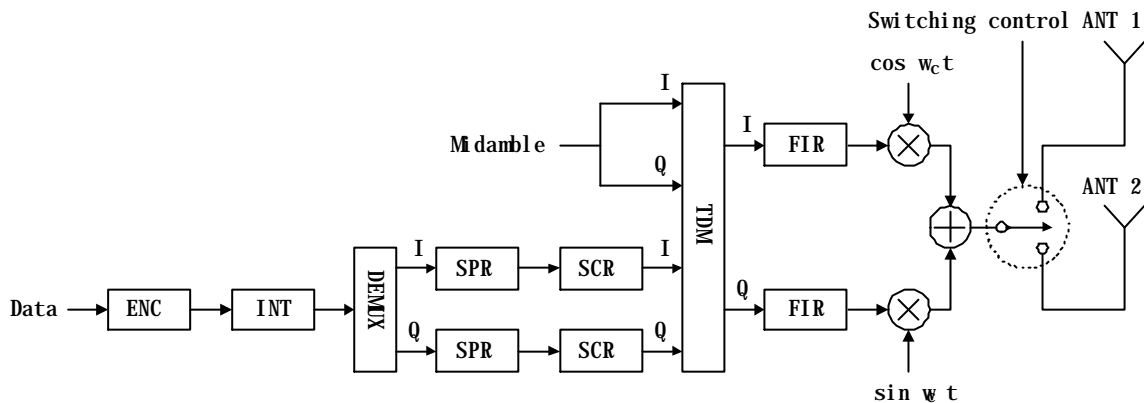

Figure [F1]: TSTD Transmitter structure for DPCH and P-CCPCH.

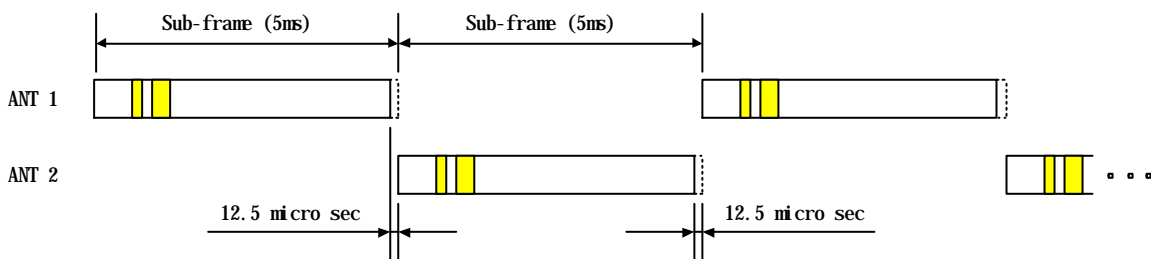

Figure [F2]: Antenna switching pattern for TSTD transmission of DPCH and P-CCPCH

5.5.1.2 Closed Loop Tx Diversity for DPCH

5.5.2 Transmit Diversity for DwPCH

TSTD can be employed as transmit diversity scheme for the downlink pilot channel DwPCH. If TSTD is employed, DwPCH is transmitted from antenna 1 and antenna 2 alternately. If P-CCPCH and DPCH employ TSTD, and DwPCH also employs TSTD, then DwPCH, P-CCPCH, and DPCH are transmitted from the same antenna within the same sub-frame as shown in figure [F2].

5.5.3 Transmit Diversity for P-CCPCH~~FPACH~~

TSTD or Block Space Time Transmit Diversity (Block STTD) can be employed as transmit diversity scheme for the Primary Common Control Physical Channel (P-CCPCH).

5.5.3.1 TSTD Transmission Scheme for P-CCPCH

A block diagram of the TSTD transmitter is shown in figure [F2]. Channel coding, rate matching, interleaving, bit-to-symbol mapping, spreading, and scrambling are performed as in the non-diversity mode. Then the data is time multiplexed with the midamble sequence. Then, after pulse shaping and modulation and amplification, P-CCPCH is transmitted from antenna 1 and antenna 2 alternately every sub-frame. An example of the antenna switching pattern is shown in figure [F2]. If P-CCPCH employs TSTD and there are other physical channels that employ TSTD, then P-CCPCH and the other physical channels that employ TSTD are transmitted from the same antenna within the same sub-frame as shown in figure [F2].

5.5.3.2 Block STTD Transmission Scheme for P-CCPCH

----- End of text proposal for working CR for 25.224 -----