

3GPP RAN 25.214 V1.3.0. (1999-09)

Technical Specification

**3rd Generation Partnership Project (3GPP);
Technical Specification Group (TSG)
Radio Access Network (RAN);
Working Group 1 (WG1);
Physical layer procedures (FDD)**



Reference

<Workitem>

Keywords

<keyword[, keyword]>

3GPP

Postal address

Office address

Internet

<http://www.3gpp.org>

Copyright Notification

Reproduction is only permitted for the purpose of standardization work undertaken within 3GPP.
The copyright and the foregoing restrictions extend to reproduction in all media.

© 3GPP 1999.
All rights reserved.

Contents

Contents	3
Intellectual Property Rights.....	5
Foreword.....	5
1 Scope	5
2 References.....	5
3 Definitions, symbols and abbreviations.....	5
3.1 Definitions	5
3.2 Symbols.....	5
3.3 Abbreviations	6
4 Synchronisation procedures.....	6
4.1 Cell search	6
4.2 Primary CCPCH synchronisation.....	7
4.3 Secondary CCPCH synchronisation	7
4.4 PRACH synchronisation.....	7
4.5 DPCCH/DPDCH synchronisation.....	7
4.5.1 General	7
4.5.2 No existing uplink dedicated channel.....	7
4.5.3 With existing uplink dedicated channel.....	8
4.6 PCPCH Synchronisation	9
5 Power control	10
5.1 Uplink power control.....	10
5.1.1 PRACH.....	10
5.1.2 DPCCH/DPDCH.....	10
5.1.2.1 General.....	10
5.1.2.2 Ordinary transmit power control.....	10
5.1.2.2.1 General	10
5.1.2.2.1.1 Out of synchronisation handling	11
5.1.2.2.2 Algorithm 1 for processing TPC commands	11
5.1.2.2.2.1 Derivation of TPC_cmd when only one TPC command is received in each slot.....	11
5.1.2.2.2.2 Combining of TPC commands known to be the same	11
5.1.2.2.2.3 Combining of TPC commands not known to be the same	11
5.1.2.2.2.3.1 General scheme	11
5.1.2.2.2.3.2 Example of the scheme	11
5.1.2.2.3 Algorithm 2 for processing TPC commands	12
5.1.2.2.3.1 Derivation of TPC_cmd when only one TPC command is received in each slot.....	12
5.1.2.3 Transmit power control in compressed mode	12
5.2 Downlink power control	13
5.2.1 Primary CCPCH	13
5.2.2 Secondary CCPCH.....	13
5.2.3 DPCCH/DPDCH.....	13
5.2.3.1 General.....	13
5.2.3.2 Ordinary transmit power control.....	14
5.2.3.3 Power control in compressed mode	14
5.2.3.4 Slow transmit power control	15
5.2.3.5 Site selection diversity transmit power control	15
5.2.3.5.1 General	15
5.2.3.5.2 Initiation of SSDT.....	15
5.2.3.5.3 Settings of temporary cell identification.....	16
5.2.3.5.3.1 Definition of temporary cell identification.....	16

5.2.3.5.3.2	Assignment of ID to each cell	17
5.2.3.5.4	TPC procedure in UE	17
5.2.3.5.5	Selection of primary cell.....	17
5.2.3.5.6	Delivery of primary cell ID.....	17
5.2.3.5.7	TPC procedure in the network	18
5.2.3.5.7.1	Management of multiple transmission power levels	18
5.2.3.5.7.2	Power setting of the downlink Dedicated Physical Channel.....	18
5.2.3.5.8	Termination of SSDT	18
5.2.4	Power Control with DSCH.....	19
6	Random access procedure	19
6.1	RACH Random Access Procedure.....	19
6.2	CPCCH Access Procedures.....	21
7	Procedures in Packet Data Transfer	22
7.1	Gated transmission in Control Only Substate.....	22
7.1.1	General	23
7.1.2	DPCCH channel with gated transmission mode	23
7.1.3	DPCCH gating during DPDCH transmission	24
7.2	Rapid Initialization of DCH for Packet Data Transfer	28
7.2.1	Rapid Initialization of DCH for Packet Data Transfer using DSCH.....	28
7.2.2	Rapid Initialization of DCH for Uplink Packet Data Transfer.....	28
7.2.3	Resumption of DCH for Downlink or Uplink Packet Data Transfer.....	29
8	Feedback mode transmit diversity.....	32
8.1	Determination of feedback information.....	32
8.2	Feedback mode 1	33
8.2.1	Mode 1 End of frame adjustment	34
8.2.2	Mode 1 Normal Initialisation.....	35
8.2.3	Mode 1 Recovery from slotted mode	35
8.3	Feedback mode 2.....	35
8.3.1	Mode 2 End of frame adjustment	37
8.3.2	Mode 2 Normal Initialisation.....	37
8.3.3	Mode 2 Recovery from slotted mode	37
9	Reverse link synchronous transmission.....	38
9.1	General	38
9.2	Initial synchronisation.....	38
9.3	Tracking process	38
9.4	Reference time.....	39
Annex A (informative): Other procedures.....		39
A.3	Antenna verification.....	39
Appendix A: Power Control Timing.....		40
History		42

Intellectual Property Rights

< Editor's note: To be filled in. >

Foreword

This specification has been produced within the Third Generation Partnership Project (3GPP), and has been elaborated by the TSG RAN WG1 working group, as a part of the work in defining and describing Layer 1 of the Universal Mobile Terrestrial Radio Access (UTRA).

This specification describes the physical layer procedures in UTRA/FDD.

1 Scope

This document specifies and establishes the characteristics of the physical layer procedures in the FDD mode of UTRA.

2 References

The following documents contain provisions which, through reference in this text, constitute provisions of the present document.

- References are either specific (identified by date of publication, edition number, version number, etc.) or non-specific.
- For a specific reference, subsequent revisions do not apply.
- For a non-specific reference, subsequent revisions do apply.
- A non-specific reference to an ETS shall also be taken to refer to later versions published as an EN with the same number.

[1] Reference 1

3 Definitions, symbols and abbreviations

3.1 Definitions

For the purposes of the present document, the following definitions apply:

<defined term>: <definition>.

3.2 Symbols

For the purposes of the present document, the following symbols apply:

<symbol> <Explanation>

3.3 Abbreviations

For the purposes of the present document, the following abbreviations apply:

ASC	Access Service Class
<u>AP</u>	<u>Access Preamble</u>
BCH	Broadcast Channel
CCPCH	Common Control Physical Channel
<u>CD</u>	<u>Collision Detection</u>
<u>CPCH</u>	<u>Common Packet Channel</u>
DCH	Dedicated Channel
DPCCCH	Dedicated Physical Control Channel
DPCH	Dedicated Physical Channel
DPDCH	Dedicated Physical Data Channel
FACH	Forward Access Channel
MUI	Mobile User Identifier
PCH	Paging Channel
<u>PCPCH</u>	<u>Physical Common Packet Channel</u>
PI	Paging Indication
PRACH	Physical Random Access Channel
RACH	Random Access Channel
SCH	Synchronisation Channel
SIR	Signal-to-Interference Ratio
SSDT	Site Selection Diversity TPC
TPC	Transmit Power Control
UE	User Equipment

4 Synchronisation procedures

4.1 Cell search

During the cell search, the UE searches for a cell and determines the downlink scrambling code and frame synchronisation of that cell. The cell search is typically carried out in three steps:

Step 1: Slot synchronisation

During the first step of the cell search procedure the UE uses the SCH's primary synchronisation code to acquire slot synchronisation to a cell. This is typically done with a single matched filter (or any similar device) matched to the primary synchronisation code which is common to all cells. The slot timing of the cell can be obtained by detecting peaks in the matched filter output.

Step 2: Frame synchronisation and code-group identification

During the second step of the cell search procedure, the UE uses the SCH's secondary synchronisation code to find frame synchronisation and identify the code group of the cell found in the first step. This is done by correlating the received signal with all possible secondary synchronisation code sequences, and identifying the maximum correlation value. Since the cyclic shifts of the sequences are unique the code group as well as the frame synchronisation is determined.

Step 3: Scrambling-code identification

During the third and last step of the cell search procedure, the UE determines the exact primary scrambling code used by the found cell. The primary scrambling code is typically identified through symbol-by-symbol correlation over the Primary CCPCH with all codes within the code group identified in the second step. After the primary scrambling code has been identified, the Primary CCPCH can be detected, super-frame synchronisation can be acquired and the system- and cell specific BCH information can be read.

If the UE has received a priority list with information about which scrambling codes to search for, steps 2 and 3 above can be simplified.

4.2 Primary CCPCH synchronisation

Synchronisation of the Primary CCPCHs is obtained during the cell search, see subclause 4.1 above. Frame synchronisation is obtained in step 2 of the cell search, and super-frame synchronisation is obtained by reading the SFN information on the BCH.

4.3 Secondary CCPCH synchronisation

Synchronisation of the Secondary CCPCHs can be obtained from the Primary CCPCH synchronisation and the timing offset information T_d broadcasted on the BCH. T_d is described in chapter 7 of 25.211.

4.4 PRACH synchronisation

Transmission of random access bursts on the PRACH is done aligned with access slot times. The timing of the access slots is derived from the received Primary CCPCH timing. The transmit timing of access slot n starts $n \times 10/N$ ms after the frame boundary of the received Primary CCPCH, where $n = 0, 1, \dots, N-1$, and N is the number of access slots per 10 ms.

4.5 DPCCH/DPDCH synchronisation

4.5.1 General

The synchronisation of the dedicated physical channels can be divided into two cases:

- when a downlink dedicated physical channel and uplink dedicated physical channel shall be set up at the same time;
- or when a downlink dedicated physical channel shall be set up and there already exist an uplink dedicated physical channel.

The two cases are described in subclauses 5.5.1 and 5.5.2 respectively.

4.5.2 No existing uplink dedicated channel

The assumption for this case is that a DPCCH/DPDCH pair shall be set up in both uplink and downlink, and that there exist no uplink DPCCH/DPDCH already. This corresponds to the case when a dedicated physical channel is initially set up on a frequency.

The synchronization establishment procedures of the dedicated physical channel is described below. The synchronization establishment process flow is shown in Figure 1.

- a) UTRAN starts the transmission of downlink DPCCH/DPDCHs. The DPDCH is transmitted only when there is data to be transmitted to the UE.
- b) The UE establishes downlink chip synchronization and frame synchronization based on the CPICH timing and timing offset information notified from UTRAN. Frame synchronization can be confirmed using the Frame Synchronization Word. Successful frame synchronization is confirmed and reported to the higher layers when S_R successive frames have been confirmed to be frame synchronized. Otherwise, frame synchronization failure is reported to the higher layers.
- c) The UE starts the transmission of the uplink DPCCH/DPDCHs at a frame timing exactly T_0 chips after the frame timing of the received downlink DPCCH/DPDCH. The DPDCH is transmitted only when there is

data to be transmitted. The UE immediately starts closed loop power control as described in sections 5.1.2 and 5.2.3, i.e. the transmission power of the uplink DPCCH/DPDCH follows the TPC commands generated by UTRAN, and the UE performs SIR estimation to generate TPC commands transmitted to UTRAN.

- d) UTRAN establishes uplink channel chip synchronization and frame synchronization.. Frame synchronization can be confirmed using the Frame Synchronization Word. Successful frame synchronization is confirmed and reported to the higher layers when S_R successive frames have been confirmed to be frame synchronized. Otherwise, frame synchronization failure is reported to the higher layers.

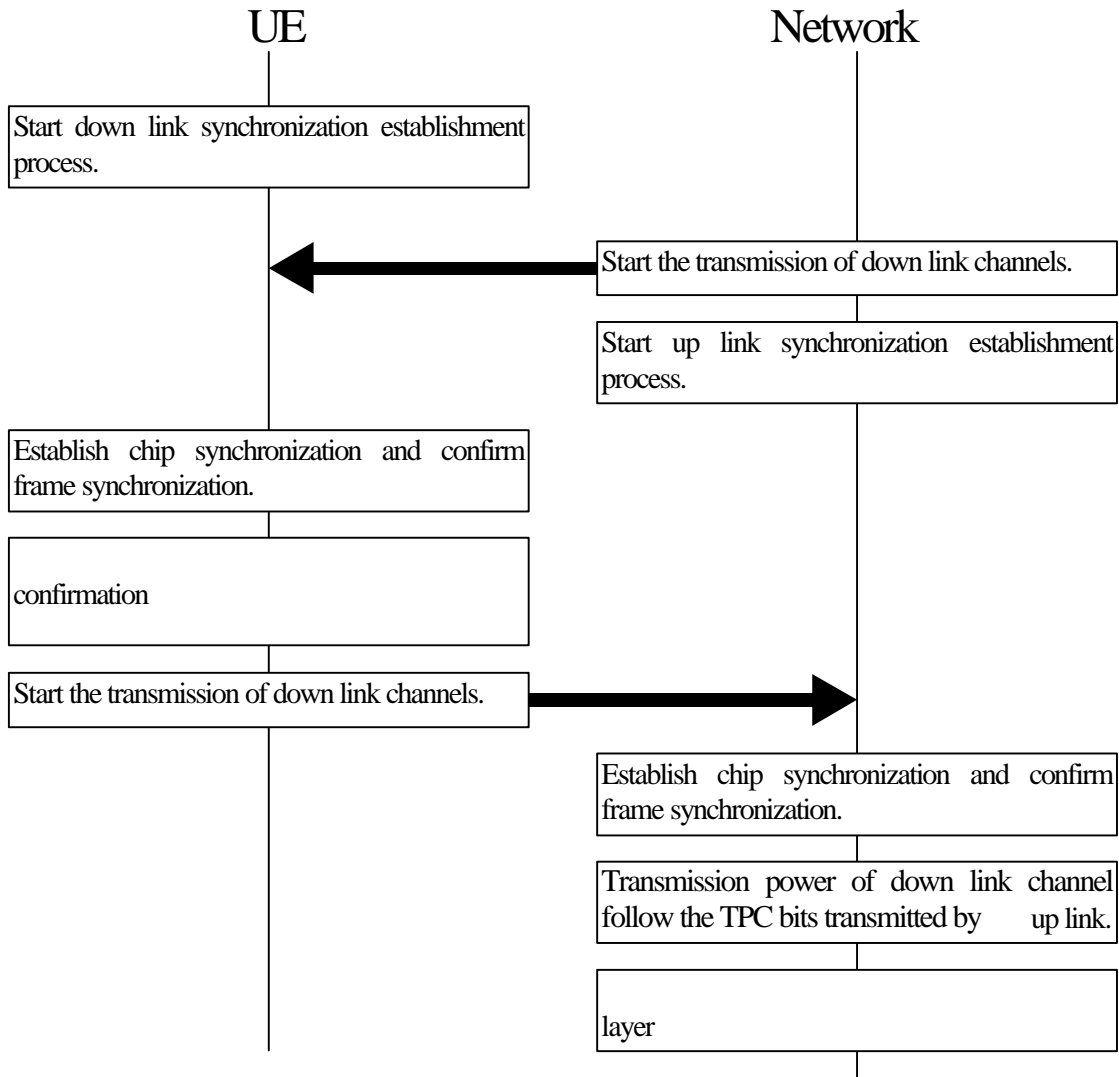

Figure 1: Synchronization establishment flow of dedicated channels

4.5.3 With existing uplink dedicated channel

The assumption for this case is that there already exist DPCCH/DPDCHs in the uplink, and a corresponding dedicated physical channel shall be set up in the downlink. This corresponds to the case when a new cell has been added to the active set in soft handover and shall begin its downlink transmission.

At the start of soft handover, the uplink dedicated physical channel transmitted by the UE, and the downlink dedicated physical channel transmitted by the soft handover source cell continues transmitting as usual.

The synchronisation establishment flow upon intra/inter-cell soft handover is described in Figure 2.

- a) The UE starts the chip synchronisation establishment process of downlink channels from the handover destination. The uplink channels being transmitted shall continue transmission as before.
- b) UTRAN starts the transmission of the downlink DPCCH/DPDCH at a frame timing such that the frame timing received at the UE will be within $T_0 \pm [148]_{128}$ chips prior to the frame timing of the uplink DPCCH/DPDCH at the UE. UTRAN then starts the synchronization establishment process of the uplink DPCCH/DPDCH transmitted by the UE. Frame synchronization can be confirmed using the Frame Synchronization Word. Successful frame synchronization is confirmed and reported to the higher layers when S_R successive frames have been confirmed to be frame synchronized. Otherwise, frame synchronization failure is reported to the higher layers.
- c) Based on the handover destination CPICH reception timing, the UE establishes chip synchronisation of downlink channels from handover destination cell. Frame synchronization can be confirmed using the Frame Synchronization Word. Successful frame synchronization is confirmed and reported to the higher layers when S_R successive frames have been confirmed to be frame synchronized. Otherwise, frame synchronization failure is reported to the higher layers.

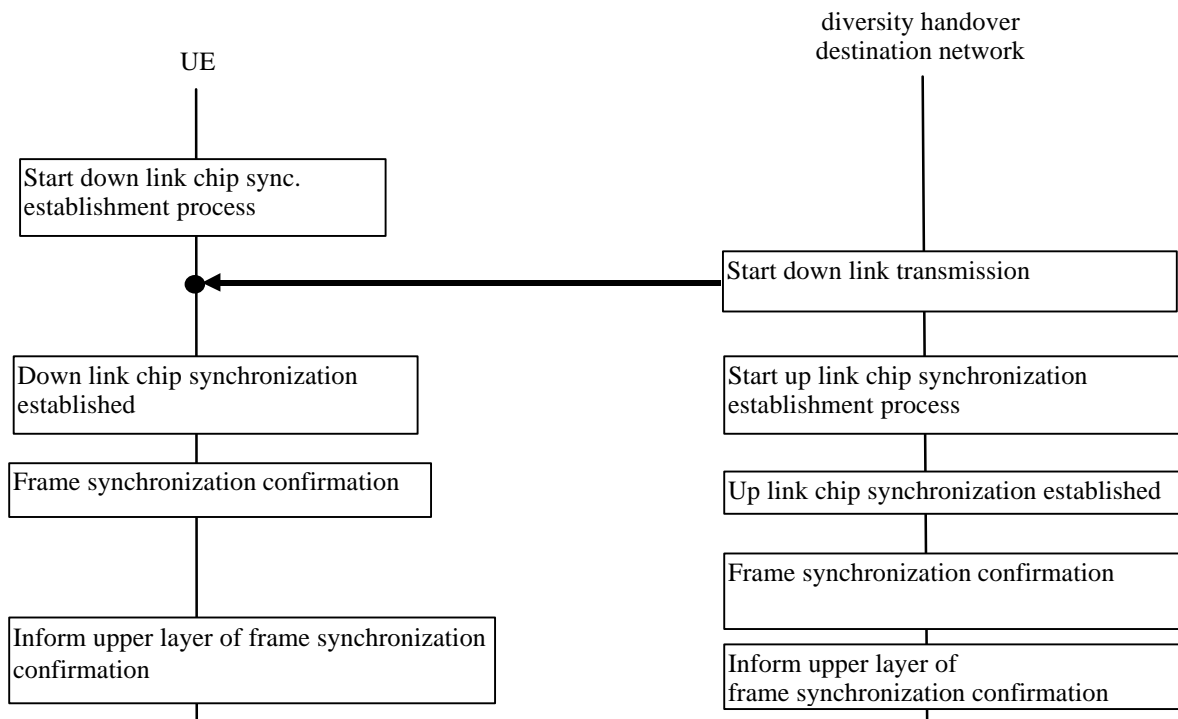

Figure 2: Synchronization establishment flow upon intra/inter-cell diversity handover

During a connection, in some cases the UE is allowed to change its transmission timing. When the UE is in soft handover with cells that all are known to have the same timing reference, the UE may adjust its DPDCH/DPCCH transmission time instant ~~by at most 1 chip during any 10 ms period.~~ <Note: maximum rate of the adjustment should be specified in R4> Otherwise, the UE may not adjust its DPDCH/DPCCH transmission time instant.

4.6 PCPCH Synchronisation

Transmission of random access bursts on the PCPCH is aligned with access slot times. The timing of the access slots is derived from the received Primary CCPCH timing. The transmit timing of access slot n starts $n \times 10/N$ ms after the frame boundary of the received Primary CCPCH, where $n = 0, 1, N-1$, and N is the number of access slots per 10 ms.

5 Power control

5.1 Uplink power control

5.1.1 PRACH

The transmitter power of UE shall be calculated by following equation:

$$P_{\text{RACH}} = L_{\text{Perch}} + I_{\text{BTS}} + \text{Constant value}$$

where,

P_{RACH} : transmitter power level in dBm,

L_{Perch} : measured path loss in dB,

I_{BTS} : interference signal power level at BTS in dBm, which is broadcasted on BCH,

Constant value: This value shall be designated via Layer 3 message (operator matter).

5.1.2 DPCCH/DPDCH

5.1.2.1 General

The uplink transmit power control procedure controls simultaneously the power of a DPCCH and its corresponding DPDCHs. The power control loop adjusts the power of the DPCCH and DPDCHs with the same amount. The relative transmit power offset between DPCCH and DPDCHs is determined by the network and signalled to the UE using higher layer signalling.

5.1.2.2 Ordinary transmit power control

5.1.2.2.1 General

The initial uplink transmit power to use is decided using an open-loop power estimate, similar to the random access procedure. < Editor's note: This needs to be elaborated, how is the estimate derived? >

The maximum transmission power at the maximum rate of DPDCH is designated for uplink and control must be performed within this range. < Editor's note: The necessity of this range needs to be confirmed. > The maximum transmit power value of the closed-loop TPC is set by the network using higher layer signalling.

The uplink closed-loop power control adjusts the UE transmit power in order to keep the received uplink signal-to-interference ratio (SIR) at a given SIR target, $\text{SIR}_{\text{target}}$. An higher layer outer loop adjusts $\text{SIR}_{\text{target}}$ independently for each cell in the active set.

The serving cells (cells in the active set) should estimate signal-to-interference ratio SIR_{est} of the received uplink DPCH. The serving cells then generates TPC commands and transmits the commands once per ms slot according to the following rule: if $\text{SIR}_{\text{est}} > \text{SIR}_{\text{target}}$ then the TPC command to transmit is "0", while if $\text{SIR}_{\text{est}} < \text{SIR}_{\text{target}}$ then the TPC command to transmit is "1".

~~If there is a single active connection and there is an idle period during the reception time of the TPC, the UE should not adjust its transmitter power.~~

Upon reception of one or more TPC commands in a slot, the UE derives a single TPC command, TPC_{cmd} , for each slot, combining multiple TPC commands if more than one is received in a slot. Two algorithms shall be supported by the UE for deriving a TPC_{cmd} , as described in subclauses 5.1.2.2.2 and 5.1.2.2.3. Which of these two algorithms is used is a UE-specific parameter and is under the control of the UTRAN. ~~In the case of idle periods for some links the combination is described in 5.1.2.2.4~~

The step size Δ_{TPC} is a UE specific parameter, under the control of the UTRAN, that can have the values 1 dB or 2 dB.

After deriving of the combined TPC command TPC_cmd using one of the two supported algorithms, the UE shall adjust the transmit power of the uplink dedicated physical channels with a step of Δ_{TPC} dB according to the TPC command. If TPC_cmd equals 1 then the transmit power of the uplink DPCCH and uplink DPDCHs shall be increased by Δ_{TPC} dB. If TPC_cmd equals -1 then the transmit power of the uplink DPCCH and uplink DPDCHs shall be decreased by Δ_{TPC} dB. If TPC_cmd equals 0 then the transmit power of the uplink DPCCH and uplink DPDCHs shall be unchanged.

Any power increase or decrease shall take place immediately before the start of the pilot field on the DPCCH.

5.1.2.2.1.1 Out of synchronisation handling

5.1.2.2.2 Algorithm 1 for processing TPC commands

5.1.2.2.2.1 Derivation of TPC_cmd when only one TPC command is received in each slot

When a UE is not in soft handover, only one TPC command will be received in each slot. In this case, the value of TPC_cmd is derived as follows:

- If the received TPC command is equal to 0 then TPC_cmd for that slot is -1.
- If the received TPC command is equal to 1, then TPC_cmd for that slot is 1.

5.1.2.2.2.2 Combining of TPC commands known to be the same

When a UE is in soft handover, multiple TPC commands may be received in each slot from different cells in the active set. In some cases, the UE has the knowledge that some of the transmitted TPC commands in a slot are the same. This is the case e.g. with receiver diversity or so called softer handover when the UTRAN transmits the same command in all the serving cells the UE is in softer handover with. For these cases, the TPC commands known to be the same are combined into one TPC command, to be further combined with other TPC commands as described in subclause 5.1.2.2.2.3.

5.1.2.2.2.3 Combining of TPC commands not known to be the same

In general in case of soft handover, the TPC commands transmitted in the different cells may be different.

This subclause describes the general scheme for combination of the TPC commands known to be different and then provides an example of such scheme. It is to be further decided what should be subject to detailed standardisation, depending on final requirements. The example might be considered as the scheme from which minimum requirement will be derived or may become the mandatory algorithm.

5.1.2.2.2.3.1 General scheme

First, the UE shall estimate the signal-to-interference ratio PC_SIR_i on each of the power control commands TPC_i , where $i = 1, 2, \dots, N$ and N is the number of TPC commands not known to be the same, that may be the result of a first phase of combination according to subclause 5.1.2.2.2.

Then the UE assigns to each of the TPC_i command a reliability figure W_i , where W_i is a function β of PC_SIR_i , $W_i = \beta(\text{PC_SIR}_i)$. Finally, the UE derives a combined TPC command, TPC_cmd , as a function γ of all the N power control commands TPC_i and reliability estimates W_i :

$\text{TPC_cmd} = \gamma(W_1, W_2, \dots, W_N, \text{TPC}_1, \text{TPC}_2, \dots, \text{TPC}_N)$, where TPC_cmd can take the values 1 or -1.

5.1.2.2.2.3.2 Example of the scheme

A particular example of the scheme is obtained when using the following definition of the functions β and γ :

For β : the reliability figure W_i is set to 0 if $PC_SIR_i < PC_thr$, otherwise W_i is set to 1. This means that the power control command is assumed unreliable if the signal-to-interference ratio of the TPC commands is lower than a minimum value PC_thr .

For γ : if there is at least one TPC_i command, for which $W_i = 1$ and $TPC_i = 0$, or if $W_i = 0$ and $TPC_i = 0$ for all N TPC_i commands, then TPC_cmd is set to 1, otherwise TPC_cmd is set to -1. Such a function γ means that the power is decreased if at least one cell for which the reliability criterion is satisfied asks for a power decrease.

5.1.2.2.3 Algorithm 2 for processing TPC commands

Note : Algorithm 2 makes it possible to emulate smaller step sizes than the minimum power control step specified in section 5.1.2.2.1, or to turn off uplink power control by transmitting an alternating series of TPC commands.

< The use or otherwise of Algorithm 2 in soft handover is FFS. >

5.1.2.2.3.1 Derivation of TPC_cmd when only one TPC command is received in each slot

When a UE is not in soft handover, only one TPC command will be received in each slot. In this case, the UE shall process received TPC commands on a 5-slot cycle, where the sets of 5 slots shall be aligned to the frame boundaries and there shall be no overlap between each set of 5 slots.

The value of TPC_cmd is derived as follows:

- For the first 4 slots of a set, $TPC_cmd = 0$.
- For the fifth slot of a set, the UE uses hard decisions on each of the 5 received TPC commands as follows:
 - If all 5 hard decisions within a set are 1 then $TPC_cmd = 1$ in the 5th slot.
 - If all 5 hard decisions within a set are 0 then $TPC_cmd = -1$ in the 5th slot.
 - Otherwise, $TPC_cmd = 0$ in the 5th slot.

~~5.1.2.2.4 Combining of TPC commands during downlink idle periods.~~

~~If one or more of the active links are idle during the reception of the TPC, the combining should be performed as in section 5.1.2.2.3 except that the reliability figures for those links are set to 0.~~

5.1.2.3 Transmit power control in compressed mode

< Note: The following is a working assumption of WGI. >

The aim of uplink power control in downlink or/and uplink compressed mode is to recover as fast as possible a signal-to-interference ratio (SIR) close to the target SIR after each transmission gap.

In downlink compressed mode, no power control is applied during transmission gaps, since no downlink TPC command is sent. Thus, the transmit powers of the uplink DPDCH(s) and DPCCH are not changed during the transmission gaps.

In simultaneous downlink and uplink compressed mode, the transmission of uplink DPDCH(s) and DPCCH is stopped during transmission gaps. <Note: the initial transmit power of each uplink DPDCH or DPCCH after the transmission gap is FFS. >

After each transmission gap, 2 modes are possible for the power control algorithm. The power control mode (PCM) is fixed and signalled with the other parameters of the downlink compressed mode (see TS 25.231). The different modes are summarised in the Table 1:

Table 1. Power control modes during compressed mode.

Mode	Description
0	Ordinary power control is applied with step size Δ_{TPC}
1	Ordinary power control is applied with step size $\Delta_{\text{RP-TPC}}$ during one or more slots after each transmission gap.

<Note: The exact power control algorithm in compressed mode when concatenation of TPC commands are used in normal mode is still FFS. The current description only applies when no concatenation is done in normal mode. >

For mode 0, the step size is not changed and the ordinary power control is still applied during compressed mode (see subclause 5.1.2.2).

For mode 1, during one or more slots after each transmission gap, called the recovery period, the ordinary power control algorithm is applied but with a step size $\Delta_{\text{RP-TPC}}$ instead of Δ_{TPC} , where $\Delta_{\text{RP-TPC}}$ is called recovery power control step size and is expressed in dB. The step size $\Delta_{\text{RP-TPC}}$ is equal to the minimum value of 3 dB and $2\Delta_{\text{TPC}}$.

After the recovery period the ordinary power control algorithm with step Δ_{TPC} is performed.

The recovery period length (RL) determination is still FFS and is to be chosen between the two following possibilities:

- The recovery period length is fixed and derived as a function of the Transmission mode parameters mostly the transmission gap period and possibly the spreading factor.
- The recovery period length is adapted and ends when the current and previous received power control commands are opposite or after TGL slots after the transmission gap.

5.2 Downlink power control

5.2.1 Primary CCPCH

The Primary CCPCH transmit power can vary on a slow basis, i.e. the power is constant over many frames. The transmit power is determined by the network and signalled on the BCH.

5.2.2 Secondary CCPCH

The Secondary CCPCH transmit power is set by the network, and may vary.

5.2.3 DPCCH/DPDCH

5.2.3.1 General

The downlink transmit power control procedure controls simultaneously the power of a DPCCH and its corresponding DPDCHs. The power control loop adjusts the power of the DPCCH and DPDCHs with the same amount, i.e. the relative power difference between the DPCCH and DPDCHs is not changed.

The relative transmit power offset between DPCCH fields and DPDCHs is determined by the network. The TFCI, TPC and pilot fields of the DPCCH are offset relative to the DPDCHs power by PO1, PO2 and PO3 dB respectively. The power offsets may vary in time. *<Note :- variation in time of the power offsets is a Working assumption>*

5.2.3.2 Ordinary transmit power control

The downlink closed-loop power control adjusts the network transmit power in order to keep the received downlink SIR at a given SIR target, SIR_{target} . A higher layer outer loop adjusts SIR_{target} independently for each connection.

The UE should estimate the received downlink DPCCH/DPDCH power of the connection to be power controlled. Simultaneously, the UE should estimate the received interference. ~~During downlink idle periods these estimations should be suspended.~~ The obtained SIR estimate SIR_{est} is then used by the UE to generate TPC commands according to the following rule: if $SIR_{est} > SIR_{target}$ then the TPC command to transmit is “0”, requesting a transmit power decrease, while if $SIR_{est} < SIR_{target}$ then the TPC command to transmit is “1”, requesting a transmit power increase.

When the UE is not in soft handover the TPC command generated is transmitted in the first available TPC field in the uplink DPCCH.

When the UE is in soft handover it should check the downlink power control mode (DPC_MODE) before generating the TPC command

- if DPC_MODE = 0 : the UE sends a unique TPC command in each slot and the TPC command generated is transmitted in the first available TPC field in the uplink DPCCH
- if DPC_MODE = 1 : the UE repeats the same TPC command over 3 slots and the new TPC command is transmitted such that there is a new command at the beginning of the frame. ~~As a response, the UTRAN may adjust its transmit power only after receiving the three TPC commands.~~

The DPC_MODE parameter is a UE specific parameter controlled by the UTRAN.

<Note : the introduction of the DPC_MODE parameter and its use are working assumptions>

As a response to the received TPC commands, UTRAN may adjust the downlink DPCCH/DPDCH power. The transmitted DPCCH/DPDCH power may not exceed Maximum_DL_Power dBm, nor may it be below Minimum_DL_Power dBm.

< Note: It is not clear to what extent the UTRAN response to the received TPC commands should be specified. Until this has been clarified, the text in the paragraph below should be seen as an example of UTRAN behaviour. >

Changes of power shall be a multiple of the minimum step size $\Delta_{TPC,min}$ dB. It is mandatory for UTRAN to support $\Delta_{TPC,min}$ of 1 dB, while support of 0.5 dB is optional.

< Note: It needs to be clarified if an upper limit on the downlink power step should be specified. >

When SIR measurements cannot be performed due to downlink out-of-synchronisation, the TPC command transmitted shall be set as “1” during the period of out-of-synchronisation.

5.2.3.3 Power control in compressed mode

The aim of downlink power control in uplink or/and downlink compressed mode is to recover as fast as possible a signal-to-interference ratio (SIR) close to the target SIR after each transmission gap.

The UE behaviour is the same in compressed mode as in normal mode, described in subclause 5.2.3.2, i.e. TPC commands should be generated based on the estimated received SIR.

The UTRAN behaviour during compressed mode is not specified. As an example, the algorithm can be similar to uplink power control in downlink compressed mode as described in sub-clause 5.1.2.3.

In downlink compressed mode or in simultaneous downlink and uplink compressed mode, the transmission of downlink DPCCCH and DPDCH(s) is stopped.

5.2.3.4 Slow transmit power control

Following an order from the network and acknowledgement by the UE, ordinary fast closed-loop transmit power control can be stopped and a slow transmit power control mode can be entered. In this mode, downlink DPCCCH/DPDCH transmit power is determined utilising power control ratios reported from the UE. Uplink transmission is suspended when the UE does not have any information to send, and the transmission is resumed to send a power control ratio at least once in every T_{RINT} second. The UE calculates power control ratios in the following steps:

1. The UE measures the CPICH power of the cell in which the UE is located, and sets the value to Q_1 .
2. The UE measures CPICH powers received from neighbouring cells, and sets the values greater than Q_1/R_{SEARCH} to Q_i , where $i = 2, 3, \dots, n$.
3. The UE sets the power control ratio to $(Q_1 + Q_2 + \dots + Q_n)/Q_1$.

All TPC bits in the uplink DPCCCH are used to send power control ratios. One power control ratio is sent per frame, i.e. 30 TPC bits are used to carry the power control ratio. The coding method is the same as that of default TFCI word described in 4.3.1.1. There are 64 code words. Code word $C_{32,m}$ corresponds to $0.5(m-1)$ dB and code word $\overline{C_{32,m}}$ corresponds to $\{0.5(m-1)+0.25\}$ dB where $m = 1, 2, \dots, 32$.

Following an order from the network, the slow transmit power control is stopped and ordinary fast closed-loop transmit power control is started. The parameters T_{RINT} and R_{SEARCH} are set using higher layer signalling.

5.2.3.5 Site selection diversity transmit power control

< Editor's note: The text could also be made more specification-like. For the time being the text is kept with some cosmetic and language related changes. >

5.2.3.5.1 General

Site selection diversity transmit power control (SSDT) is an optional macro diversity method in soft handover mode.

Operation is summarised as follows. The UE selects one of the cells from its active set to be 'primary', all other
The main objective is to transmit on the downlink from the best cell, thus reducing the interference caused by multiple transmissions in a soft handover mode. A second objective is to achieve fast site selection without network intervention, thus maintaining the advantage of the soft handover. In order to select a primary cell, each cell is assigned a temporary identification and UE periodically informs a primary cell identification to the connecting cells. The non-primary cells selected by UE switch off the transmission power. The primary cell identity code is delivered via uplink FBI field.

5.2.3.5.2 Initiation of SSDT

The SSDT is initiated by the network, based on the soft handover active cell set. The cell and UE are subsequently informed by the network that the SSDT option has been activated during the current soft handover period. Otherwise, TPC is operated in the ordinary mode, i.e. each cell controls its power in accordance with an uplink TPC command by the way described in 5.2.3.2. The temporary cell identification assignment (i.e. ID code assignment) is carried out by network which is communicated to all the active cells and the UE.

After the activation of the SSDT and the subsequent UE acknowledgements, the UE starts to send the "primary" cell ID code, described in the following subclauses. Following a successful activation of SSDT and reception of the UE acknowledgement, the active cells start detecting the "primary" cell ID information.

5.2.3.5.3 Settings of temporary cell identification

Each cell is given a temporary identification during SSDT and the identification is utilised as site selection signal. In the following, the temporary identification is referred to as "ID".

5.2.3.5.3.1 Definition of temporary cell identification

The ID is given a binary bit sequence. There are three different lengths of coded ID available denoted as "long", "medium" and "short". The network decides which length of coded ID is used and notifies it to both UE and cells by higher layer signaling message in the initiation of SSDT. Settings of ID codes for 1-bit and 2-bit FBI are exhibited in Table 2 and Table 3, respectively.

Table 2 Settings of ID codes for 1 bit FBI

ID label	ID code		
	"long"	"medium"	"short"
a	00000000000000	000000(0)	0000
b	11111111111111	111111(1)	1111
c	00000000111111	000011(1)	0001
d	11111111000000	111100(0)	1110
e	00001111111100	001111(0)	0011
f	11110000000011	110000(1)	1100
g	00111100001110	011001(0)	0101
h	11000011110001	100110(1)	1010

Table 3 Settings of ID codes for 2 bit FBI

ID label	ID code (Column and Row denote slot position and FBI-bit position.)		
	"long"	"medium"	"short"
a	000000(0)	000(0)	000
	000000(0)	000(0)	000
b	111111(1)	111(1)	111
	111111(1)	111(1)	111
c	000000(0)	000(0)	000
	111111(1)	111(1)	111
d	111111(1)	111(1)	111
	000000(0)	000(0)	000
e	000011(1)	001(1)	001
	111100(0)	110(0)	100
f	111100(0)	110(0)	110
	000011(1)	001(1)	011
g	001111(0)	011(0)	010
	001111(0)	011(0)	010
h	110000(1)	100(1)	101
	110000(1)	100(1)	101

ID must be terminated within a frame. If FBI space for sending a given ID cannot be obtained within a frame, hence if the entire ID is not transmitted within a frame but must be split over two frames, the last bit(s) of the ID is(are) punctured. The relating bit(s) to be punctured are shown with brackets in Table 2 and Table 3.

5.2.3.5.3.2 Assignment of ID to each cell

The ID assignment to each cell is carried out by network and the assignment result is informed to active cells and UE. Every time that the active list is changed, it shall be informed to all active cells and UE via the higher layer signaling.

Table 4: ID-assignment example

Number of cells in active set	ID label assignment for each cell					
	Cell index					
	1	2	3	4	5	6
1	a					
2	a	b				
3	a	b	e			
4	a	b	e	d		
5	a	b	e	d	e	
6	a	b	e	d	e	f

5.2.3.5.4 TPC procedure in UE

The TPC procedure of the UE in SSdT is identical to that described in subclause 5.2.3.2.

5.2.3.5.5 Selection of primary cell

The UE selects a primary cell periodically by measuring reception levels of common pilots transmitted by the active cells. The cell with the highest pilot power is detected as a primary cell.

5.2.3.5.6 Delivery of primary cell ID

The UE periodically sends the ID code of the primary cell via portion of the uplink FBI field assigned for SSdT use (FBI S field). A cell recognises its state as non-primary if the following two conditions are fulfilled simultaneously:

- the received primary ID code does not match with the own ID code,
- and the received uplink signal quality satisfies a quality threshold, Q_{th} , a parameter defined by the network.

Otherwise the cell recognises its state as primary.

At the UE, the primary ID code to be sent to the cells is segmented into a number of portions. These portions are distributed in the uplink FBI S-field. The cell in SSdT collects the distributed portions of the primary ID code and then detects the transmitted ID. Period of primary cell update depends on the settings of code length and the number of FBI bits assigned for SSdT use as shown in Table 4

Table 4 Period of primary cell update

code length	The number of FBI bits per slot assigned for SSdT	
	1	2
"long"	1 update per frame	2 updates per frame
"medium"	2 updates per frame	4 updates per frame
"short"	3 updates per frame	5 updates per frame

5.2.3.5.7 TPC procedure in the network

In SSDT, a non-primary cell can switch off its output power (i.e. no transmissions).

5.2.3.5.7.1 Management of multiple transmission power levels

The cell manages two downlink transmission power levels, P1, and P2, for each UE in soft handover. Power level P1 keeps track of the minimum downlink power required, if the cell is chosen as the primary cell. The cell updates P1 regardless of the selected state (primary or non-primary). The data fields from non-primary cells are transmitted at power level P2. When a cell is selected by the UE as the primary cell, P2 is set to P1, otherwise the cell maintains P2 at the minimum transmit level (i.e. data fields power off). P1 and P2, expressed in dBm, are updated in accordance with TPC commands from the UE as shown in Table 5. The two power settings P1 and P2 are maintained within the power control dynamic range.

Table 5: Updating of P1 and P2

State of cell	TPC signal	P1	P2
non primary	down	$P1 - \Delta_{TPC}$	Switched off
	up	$P1 + \Delta_{TPC}$	Switched off
primary	down	$P1 - \Delta_{TPC}$	= P1
	up	$P1 + \Delta_{TPC}$	= P1

Δ_{TPC} is defined in subclause 5.2.3.2. < Editor's note: Maybe it is not defined in standard, see comment in 5.2.3.2. > No regulation of initial value of P1 and P2 is given.

5.2.3.5.7.2 Power setting of the downlink Dedicated Physical Channel

The downlink Dedicated Physical Channel is partitioned into 5 portions as shown in Figure 9 of S25.211. Power setting of each portion during SSDT is depicted in Figure 3.

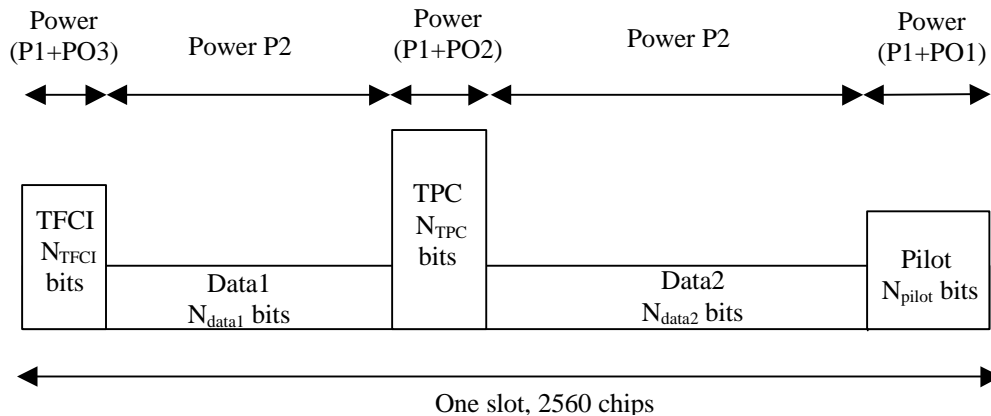

Figure 3: Power setting of the downlink Dedicated Physical Channel

Transmission power of the TPC and TFI portions are always set to P1, in order to detect the control information at the UE with high reliability.

5.2.3.5.8 Termination of SSDT

The decision to terminate the SSDT is made by the network, The termination request should be informed by the network to both cells and UE The signaling methods regarding SSDT termination are described in the higher layer specifications in detail.

5.2.4 Power Control with DSCH

The DSCH power control can be based on the following solutions, which are selectable, by the network.

- Fast closed loop power control based on the power control commands sent by the UE on the uplink DPCCH.
- Slow power control.

6 Random access procedure

6.1 RACH Random Access Procedure

Before the random-access procedure is executed, the UE should acquire the following information from the BCH :

- The preamble spreading code(s) / message scrambling code(s) used in the cell
- The available signatures , and sub RACH channel(s) groups for each ASC, where a sub-channel group is defined as a group of some of the sub-channels defined in Table 6, and is indicated by upper layer.
- The available spreading factors for the message part
- The uplink interference level in the cell
- The primary CCPCH transmit power level
- The AICH transmission timing parameter as defined in 25.211.
- The power offset ΔP_{p-m} between preamble and the message part.
- The power offsets ΔP_0 (power step when no acquisition indicator is received, step 7.3) and ΔP_1 (power step when negative acquisition is received, see step 8.3)

The random-access procedure is:

1. The UE randomly selects a preamble spreading code from the set of available spreading codes. The random function is TBD.
2. The UE sets the preamble transmit power to the value P_{RACH} given in Section 5.1.1. [*Editor's note: Here it is assumed that the initial power back-off is included in the "Constant Value" of 5.1.1*]
3. The UE implements the dynamic persistence algorithm by:
 - 3.1 Monitor the broadcast channel (BCH).
 - 3.2 Read the current persistence factor, N , from the BCH.
 - 3.3 If $N = 0$, the UE proceeds to step 4. Otherwise, the UE generate an integer uniform random variable R in the interval $[0, 1, \dots, 2^N - 1]$.
 - 3.4 If the outcome of the random draw $R = 0$, the UE proceeds to step 4. Otherwise, the UE defers the transmission of the message for one frame and repeats step 3.
- 4 The UE:
 - 4.1 Randomly selects the sub RACH channel group from the available ones for its ASC, The random function, for selecting the sub RACH channel group from the available ones is TBD.

- 4.2 Derives the available access slots in the next two frames, defined by SFN and SFN+1 in the selected sub-RACH channel group with the help of SFN and Table 6. Randomly selects one access slot from the available access slots in the next frame, defined by SFN, if there is one available. If there is no access slot available in the next frame, defined by SFN then, randomly selects one access slot from the available access slots in the following frame, defined by SFN+1. Random function is TBD.
- 4.3 Randomly selects a signature from the available signatures within the ASC given by higher layers. Random function is TBD.
- 5 The UE sets the Preamble Retransmission Counter to Preamble_Retrans_Max (value TBD).
- 6 The UE transmits its preamble using the selected uplink access slot, signature, and preamble transmission power..
- 7 If the UE does not detect the positive or negative acquisition indicator corresponding to the selected signature in the downlink access slot corresponding to the selected uplink access slot, the UE:
 - 7.1 Selects a new uplink access slot, as next available access slot, i.e. next slot in the sub-channel group used, as selected in 4.1
 - 7.2 Randomly selects a new signature from the available signatures within the ASC given by higher layers. Random function is TBD.
 - 7.3 Increases the preamble transmission power with the specified offset ΔP_0 .
 - 7.4 Decrease the Preamble Retransmission Counter by one.
 - 7.5 If the Preamble Retransmission Counter > 0 , the UE repeats from step 6 otherwise an error indication is passed to the higher layers and the random-access procedure is exited.
8. If the UE detects the negative acquisition indicator corresponding to the selected signature in the downlink access slot corresponding to the selected uplink access slot, the UE:
 - 8.1 Selects a new uplink access slot as in 7.1
 - 8.2 Randomly selects a new signature from the available signatures within the ASC given by higher layers. Random function is TBD.
 - 8.3 Modifies the preamble transmission power with the specified offset ΔP_1 .
 - 8.4 Repeats from step 6
9. The UE transmits its random access message three or four uplink access slots after the uplink access slot of the last transmitted preamble depending on the AICH transmission timing parameter. Transmission power of the random access message is modified from that of the last transmitted preamble with the specified offset ΔP_{p-m} .
10. A indication of successful random-access transmission is passed to the higher layers.

Dynamic persistence is provided for managing interference and minimising delay by controlling access to the RACH channel. The system will publish a dynamic persistence value on the BCH, the value of which is dependent on the estimated backlog of users in the system.

Table 6. The available access slots, Access, for different sub-RACH channels

Frame number	Sub-channel Number											
	0	1	2	3	4	5	6	7	8	9	10	11
SFN modulo 8=0	0	1	2	3	4	5	6	7				

SFN modulo 8=1	12	13	14						8	9	10	11
SFN modulo 8=2				0	1	2	3	4	5	6	7	
SFN modulo 8=3	9	10	11	12	13	14						8
SFN modulo 8=4	6	7					0	1	2	3	4	5
SFN modulo 8=5			8	9	10	11	12	13	14			
SFN modulo 8=6	3	4	5	6	7					0	1	2
SFN modulo 8=7						8	9	10	11	12	13	14

6.2 CPCH Access Procedures

<Editor's note: This clause is W.A., not agreement, Contents are to be determined in WGI#7bis>

For each CPCH physical channel allocated to a cell the following physical layer parameters are included in the System Information message:

- UL Access Preamble (AP) scrambling codeset.
- AP- AICH preamble channelization code set.
- UL CD preamble scrambling code set.
- CD-AICH preamble channelization code set.
- CPCH UL scrambling code set.
- CPCH UL channelization code set. (variable, data rate dependant)
- DPCCH DL channelization code set.([256] chip)

The following are access, collision detection/resolution and CPCH data transmission parameters:

Power ramp-up, Access and Timing parameters (Physical layer parameters)

1. $N_{AP_retrans_max}$ = Maximum Number of allowed consecutive access attempts (retransmitted preambles) if there is no AICH response. This is a CPCH parameter and is equivalent to Preamble Retrans Max in RACH.

2. $P_{RACH} \equiv P_{CPCH}$ = Initial open loop power level for the first CPCH access preamble sent by the UE.

[RACH/CPCH parameter]

3. ΔP_0 = Power step size for each successive CPCH access preamble.

[RACH/CPCH parameter]

4. ΔP_1 = Power step size for each successive RACH/CPCH access preamble in case of negative AICH

[RACH/CPCH]

5. T_{cpch} = CPCH transmission timing parameter: The range of T_{cpch} values is TBD. This parameter is similar to PRACH/AICH transmission timing parameter.

The CPCH -access procedure in the physical layer is:

1. The UE sets the preamble transmit power to the value P_{CPCH} , which is supplied by the MAC layer for initial power level for this CPCH access attempt.
2. The UE sets the AP Retransmission Counter to $N_{\text{AP Retrans Max}}$ (value TBD).
3. The UE transmits the AP using the MAC supplied uplink access slot, signature, and initial preamble transmission power.
4. If the UE does not detect the positive or negative acquisition indicator corresponding to the selected signature in the downlink access slot corresponding to the selected uplink access slot, the UE:
 - a. Selects a new uplink access slot. This new access slot must be one of the available access slots. There must be also a distance of three or four access slots from the uplink access slot in which the last preamble was transmitted depending on the CPCH/AICH transmission timing parameter. The selection scheme of this new access slot is TBD.
 - b. Increases the preamble transmission power with the specified offset P_0 .
 - c. Decrease the Preamble Retransmission Counter by one.
 - d. If the Preamble Retransmission Counter < 0 , the UE aborts the access attempt and sends a failure message to the MAC layer.
5. If the UE detects the negative acquisition indicator corresponding to the selected signature in the downlink access slot corresponding to the selected uplink access slot, the UE aborts the access attempt and sends a failure message to the MAC layer.
6. Upon reception of AP-AICH, the access segment ends and the contention resolution segment begins. In this segment, the UE randomly selects one of 16 signatures and transmits a CD Preamble, then waits for a CD-AICH from the base Node.
7. If the UE does not receive a CD-AICH in the designated slot, the UE aborts the access attempt and sends a failure message to the MAC layer.
8. If the UE receives a CD-AICH in the designated slot with a signature that does not match the signature used in the CD Preamble, the UE aborts the access attempt and sends a failure message to the MAC layer.
9. If the UE receives a CD-AICH with a matching signature, the UE transmits the power control preamble $\tau_{\text{cd-p-pc-p}}$ ms later as measured from initiation of the CD Preamble. . The transmission of the message portion of the burst starts immediately after the power control preamble.
10. During CPCH Packet Data transmission, the UE and UTRAN perform closed loop power control on both the CPCH UL and the DPCCH DL.
11. If the UE detects loss of DPCCH DL during transmission of the power control preamble or the packet data, the UE halts CPCH UL transmission, aborts the access attempt and sends a failure message to the MAC layer.
12. If the UE completes the transmission of the packet data, the UE sends a success message to the MAC layer.

7. Procedures in Packet Data Transfer

7.1 Gated transmission in Control Only Substate

[Note: Gated transmission in control only state is WA, not agreement in R1.]

7.1.1 General

The gated transmission of DPCCH in Control Only Substates(COS) may be initiated by the UTRAN to reduce the transmission rate of Pilot, TPC, TFCI or FBI.

7.1.2 DPCCH channel with gated transmission mode

The downlink and uplink DPCCH can be transmitted with the gated transmission mode enabled or disabled, as described in Figure 4.

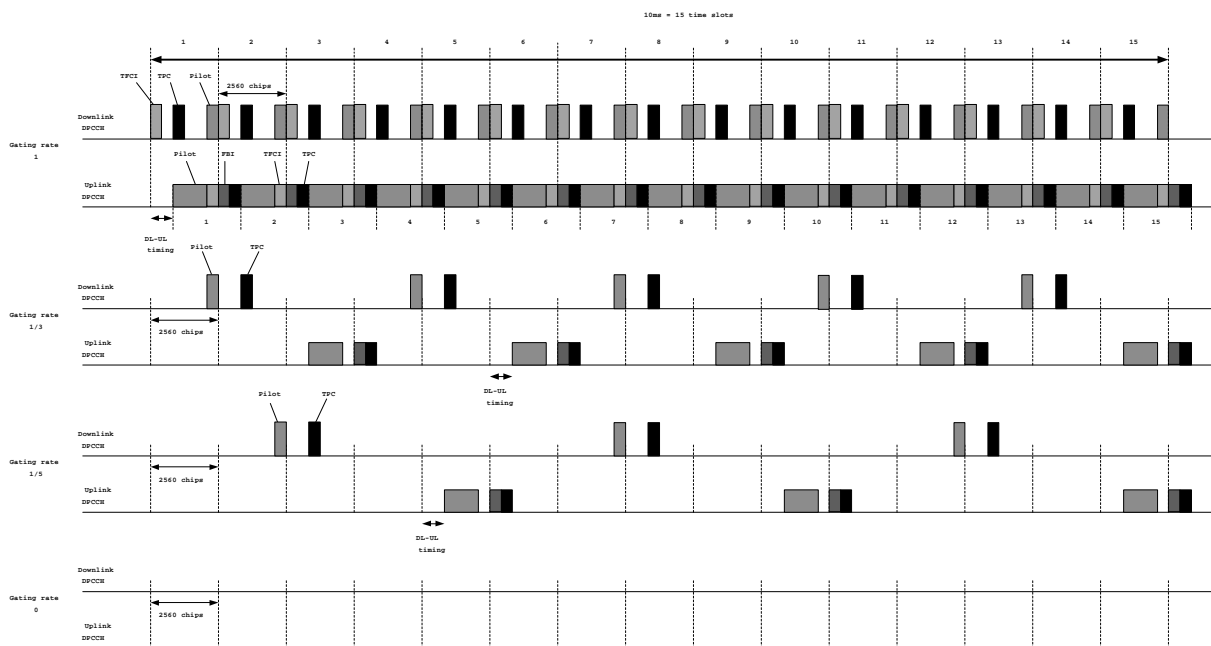

Figure 4. Downlink and uplink DPCCH transmission timing

When the gated transmission mode is disabled (i.e. the gating rate =1), the UTRAN and UE shall transmit the DPCCH in every time slot. When the gated transmission mode is enabled, the UTRAN and UE shall transmit the DPCCH only in the time slots that are gated on, as specified in Figure 4. The relative timings of the downlink and uplink DPCCH transmission when the gated transmission mode is enabled and disabled are depicted in Figure 4. When transmitting only on the DPCCH, the UTRAN and UE may periodically gate off certain time slots of DPCCH at a rate specified by the gating rate which may be continuous(=1 rate), 1/3 rate, 1/5, or 0 rate. The downlink DPCCH allocations are given in Table 7 and the uplink DPCCH allocations are given in Table 8.

Table 7 Downlink DPCCH allocations during gated transmission mode enabled

Gating Rate	Downlink DPCCH allocations (time slot numbers 1-15)	
	Pilot	TPC
1	1, 2, 3, 4, 5, 6, 7, 8, 9, 10, 11, 12, 13, 14, 15	1, 2, 3, 4, 5, 6, 7, 8, 9, 10, 11, 12, 13, 14, 15

1/3	1, 4, 7, 10, 13	2, 5, 8, 11, 14
1/5	2, 7, 12	3, 8, 13
0	-	-

Table 8. Uplink DPCCH allocations during gated transmission mode enabled

Gating Rate	Uplink DPCCH allocations (time slot numbers 1-15)	
	Pilot	FBI, TPC
1	1, 2, 3, 4, 5, 6, 7, 8, 9, 10, 11, 12, 13, 14, 15	1, 2, 3, 4, 5, 6, 7, 8, 9, 10, 11, 12, 13, 14, 15
1/3	3, 6, 9, 12, 15	3, 6, 9, 12, 15
1/5	5, 10, 15	5, 10, 15
0	-	-

7.1.3_DPCCH gating during DPDCH transmission

Gating patterns for the downlink DPCCH with gating rate of 1, 1/3, 1/5, and 0 are given in Table 9. Gating patterns for the uplink DPCCH with gating rate of 1, 1/3, 1/5, and 0 are given in Table 10. Downlink DPCCH gating during DPDCH transmission is depicted in Figure 5. Uplink DPCCH gating during DPDCH transmission is depicted in Figure 6. When there is transmission on the DPDCH, the DPCCH shall be gated on (i.e. shall have a gating rate=1) for the duration of the active DPDCH frame, as given in Table 9 and Table 10. However, downlink TPC shall continue gate off with gating rate during downlink DPDCH transmission. Uplink TPC and FBI shall continue gate off with gating rate during uplink DPDCH transmission.

Table 9 Downlink DPCCH allocations during DPDCH transmission

Gating Rate	Downlink DPCCH allocations (time slot numbers 1-15)	
	Pilot, TFCI	TPC
1	1, 2, 3, 4, 5, 6, 7, 8, 9, 10, 11, 12, 13, 14, 15	1, 2, 3, 4, 5, 6, 7, 8, 9, 10, 11, 12, 13, 14, 15
1/3	1, 2, 3, 4, 5, 6, 7, 8, 9, 10, 11, 12, 13, 14, 15	2, 5, 8, 11, 14
1/5	1, 2, 3, 4, 5, 6, 7, 8, 9, 10, 11, 12, 13, 14, 15	3, 8, 13
0	1, 2, 3, 4, 5, 6, 7, 8, 9, 10, 11, 12, 13, 14, 15	1, 2, 3, 4, 5, 6, 7, 8, 9, 10, 11, 12, 13, 14, 15

Table 10 Uplink DPCCH allocations during DPDCH transmission

Gating Rate	Uplink DPCCH allocations (time slot numbers 1-15)	
	Pilot, TFCI	FBI, TPC
1	1, 2, 3, 4, 5, 6, 7, 8, 9, 10, 11, 12, 13, 14, 15	1, 2, 3, 4, 5, 6, 7, 8, 9, 10, 11, 12, 13, 14, 15

$1/3$	1, 2, 3, 4, 5, 6, 7, 8, 9, 10, 11, 12, 13, 14, 15	3, 6, 9, 12, 15
$1/5$	1, 2, 3, 4, 5, 6, 7, 8, 9, 10, 11, 12, 13, 14, 15	5, 10, 15
0	1, 2, 3, 4, 5, 6, 7, 8, 9, 10, 11, 12, 13, 14, 15	1, 2, 3, 4, 5, 6, 7, 8, 9, 10, 11, 12, 13, 14, 15

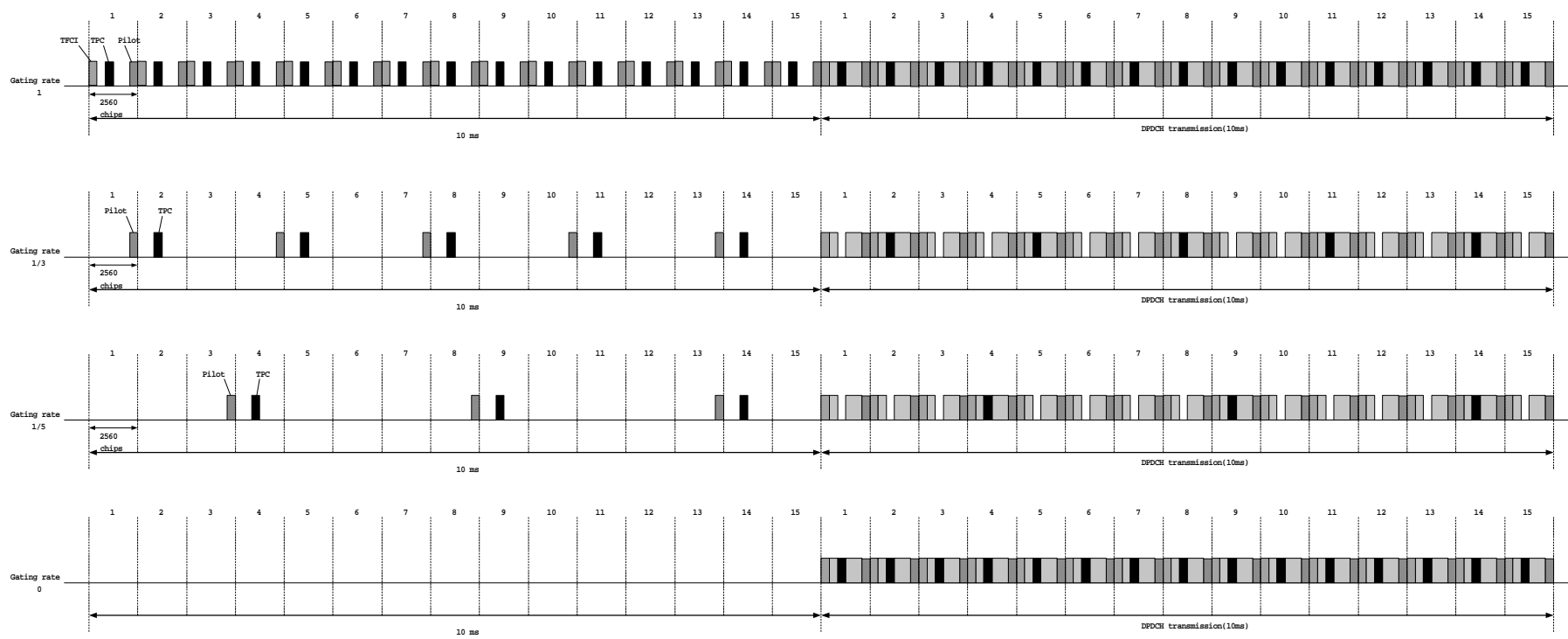

Figure 5 Downlink DPCCH gating during DPDCH transmission

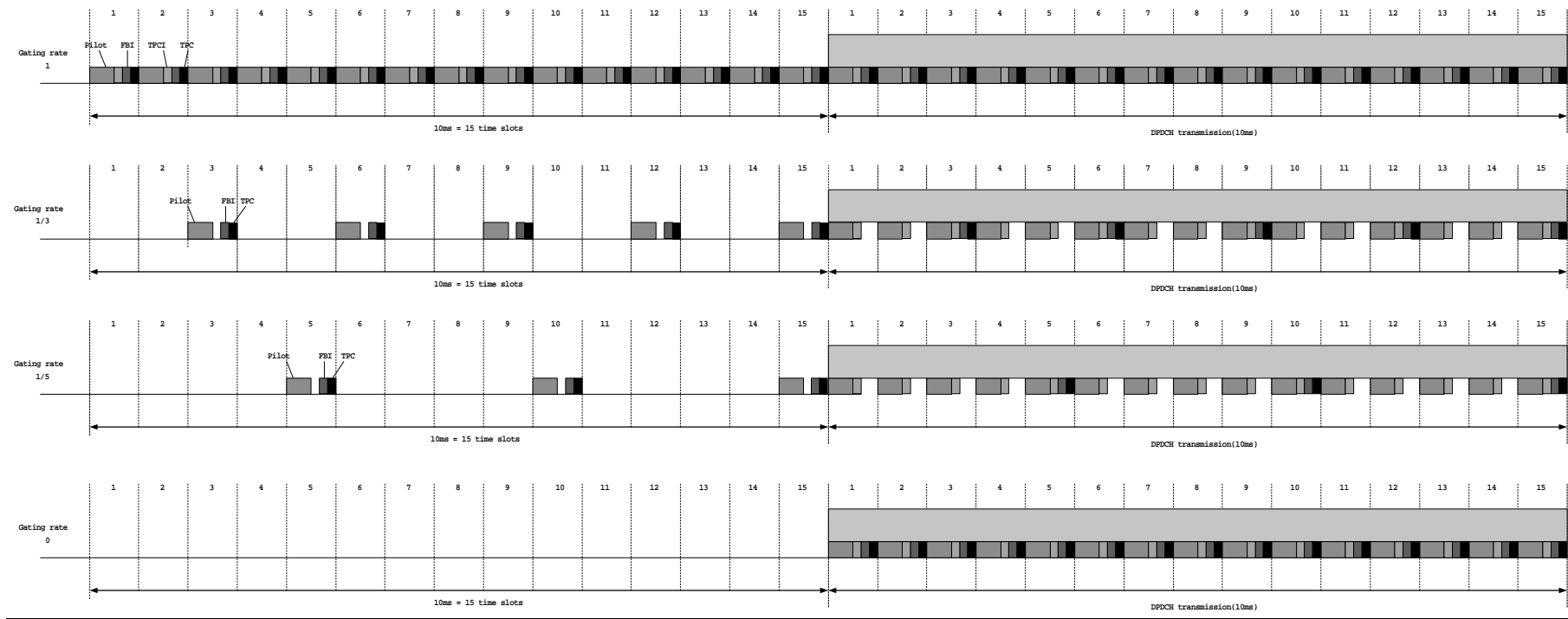

Figure 6 Uplink DPCCH gating during DPDCH transmission

7.2 Rapid Initialization of DCH for Packet Data Transfer

A rapid initialization procedure for establishing a DCH is defined to support bursting packet data transfer. The rapid initialization may be invoked for downlink packet data transfer on the DSCH or uplink packet data transfer on the DCH. The procedure may also be invoked to resume a recently discontinued DCH connection.

7.2.1 Rapid Initialization of DCH for Packet Data Transfer using DSCH

The synchronization of the DSCH/DCH pair may be expedited so that data transmission using DSCH can commence in slightly over 10 ms following the FACH burst assigning the TFCI using DCH. Figure 7 shows the timing diagram of RACH/FACH to DCH/DCH+DSCH state transition. The parameter T_A specifies the RACH/FACH response time. The parameters T_B , T_C and T_D are referenced relative to the FACH frame. T_B specifies the time period when the downlink DPCCH is started. The parameter T_C specifies the period at which the UE will start the uplink DPCCH. Finally, T_D specifies the period that the DCH will be stable and the first frame of data may arrive. The parameters T_B , T_C , and T_D have the following relationship:

$$T_B < T_C \ll T_D$$

$$T_D = T_B + N_{slots} * 0.666$$

where N_{slots} is a positive integer.

In order to initialise fast uplink link power control loop, searcher and channel estimator at the Node B, the UE will adhere to the following:

- The transmission of uplink link DPCCH will start at N_{slots} slots (1 to 15 slots) prior to the scheduled downlink packet data transmission using DSCH.
- The DPCCH will be transmitted with an additional negative power offset P_{offset} from the computed open loop estimate.
- The initial power control step size for transmitting the DPCCH will be set at P_{step} (typically: 2dB).
- The UE will revert back to the normal power control (PC) step size upon the receipt of the first down power control command during the uplink DPCCH transmission phase,
- The step size always goes back to its nominal setting in the beginning of DSCH transmission

The parameters T_B , T_C , T_D , N_{slots} , P_{offset} and P_{step} may be negotiated with each individual UE or broadcast by the system so that the transition from RACH/FACH to DCH/DCH+DSCH sub-state is optimised.

7.2.2 Rapid Initialization of DCH for Uplink Packet Data Transfer

The synchronization of the DCH may also be expedited for the transfer of uplink packet data.. Figure 8 shows the same parameters T_B , T_C , and T_D applied to an uplink packet data transfer. The UE, upon detecting data in its queue, transmits a RACH with measurement report. After the UTRAN assigns the DCH via the FACH message, the downlink DPCCH is started after a time period T_B . The UE then begins transmission of the uplink DPCCH for reasons as outlined in section 7.3.4 at time period T_C . T_C is measured relative to the FACH transmit timing. Finally, the UE begins transmitting the data on the DPCCH after the period. The procedure for starting the uplink DPCCH transmission will be similar to Section 7.3.4.1

7.2.3 Resumption of DCH for Downlink or Uplink Packet Data Transfer

The synchronization of the DCH technique may be used to resume a DCH/DCH+DSCH connection that has been dropped for a short period.. This is applicable for packet data transfer using DSCH or uplink DPDCH or bi-directional data transfer using DSCH/Uplink DPDCH. Figure 9 shows the case where the DCH has been discontinued based on an inactivity timer T_E . The UTRAN, upon detecting data in the queue, may resume the DCH operation provided the period T_E has not elapsed. Typically T_E is set to 1000msec.

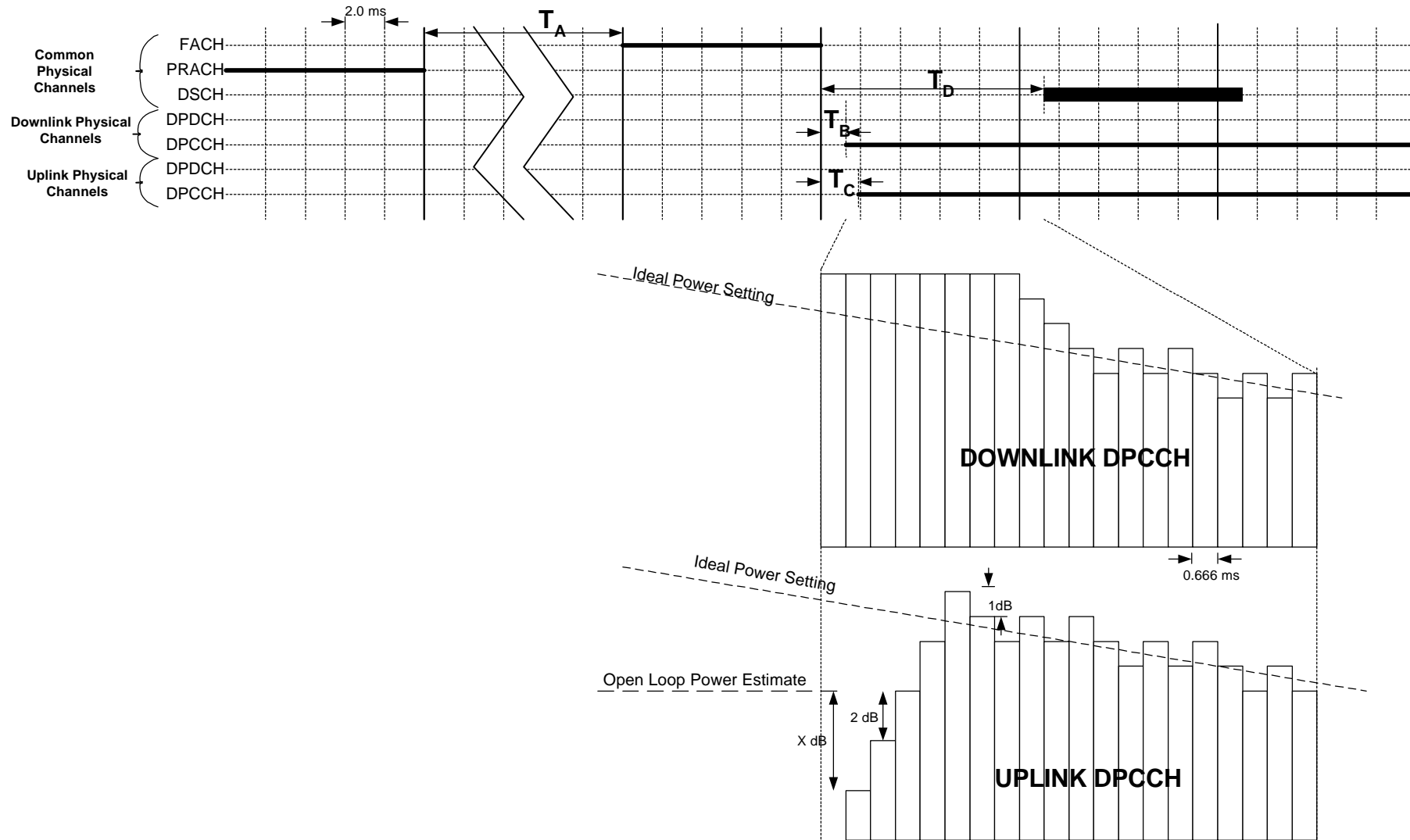

Figure 7 Rapid Initialization of DCH for packet data transfer over the DSCH.

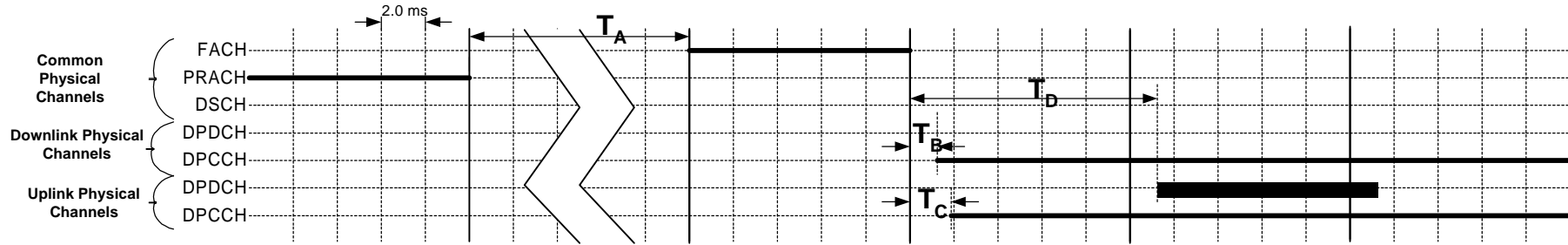

Figure 8 Rapid initialization of the DCH for transfer of uplink packet data.

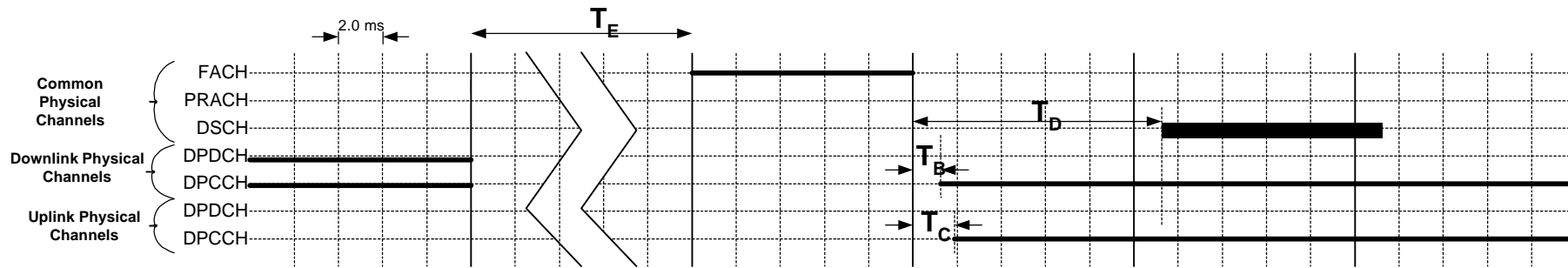

Figure 9 Resumption of the DCH for transmission of downlink packet data.

8 Feedback mode transmit diversity

The general transmitter structure to support Feedback (FB) mode transmit diversity for DPCH transmission is shown in Figure 10. Channel coding, interleaving and spreading are done as in non-diversity mode. The spread complex valued signal is fed to both TX antenna branches, and weighted with antenna specific weight factors w_1 and w_2 . The weight factors are complex valued signals (i.e., $w_i = a_i + jb_i$), in general.

The weight factors (actually the corresponding phase adjustments) are determined by the UE, and signaled to the UTRAN access point (=cell transceiver) using the D-bits of the FBI field of uplink DPCH.

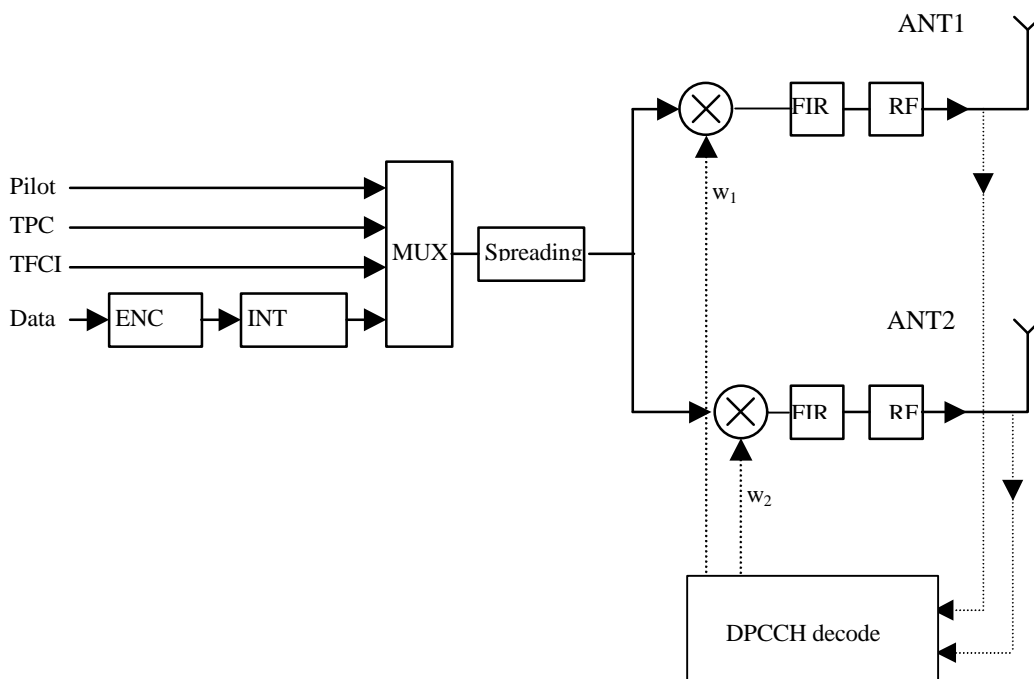

Figure 10. The generic downlink transmitter structure to support FB Mode Transmit Diversity for DPCH transmission (UTRAN Access Point)

There are twofeedback modes whose characteristics are summarized in the Table 11. The use of the modes is controlled by the UTRAN access point.

Table 11: Summary of number of feedback information bits per slot, N_{FBD} , feedback command length in slots, N_w , feedback command rate, feedback bit rate, number of phase bits, N_{ph} , per signaling word and amount of constellation rotation at UE for the two feedback modes.

FB mode	N_{FBD}	N_w	Update rate	Feedback bit rate	N_{po}	N_{ph}	Constellation rotation
1	1	1	1500 Hz	1500 bps	0	1	$\pi/2$
2	1	4	1500 Hz	1500 bps	1	3	N/A

8.1 Determination of feedback information

The UE uses the Common Pilot CHannel (CPICH) to separately estimate the channels seen from each antenna.

Once every slot, the UE computes the phase adjustment, f , and for mode 2 the amplitude adjustment that should be applied at the UTRAN access point to maximize the UE received power. In a generic sense for the non-soft handover case, UE solves for weight vector, \underline{w} , that maximizes

$$P = \underline{w}^H H^H H \underline{w} \tag{1}$$

where

$$H = [h_1 \ h_2 \ \dots]$$

and where the column vector h_i represents the estimated channel impulse response for the i 'th transmission antenna, of length equal to the length of the channel impulse response. The elements of w correspond to the phase and amplitude adjustments computed by the UE.

During soft handover or SSdT power control, the antenna weight vector, w is determined so as to maximize the criteria function,

$$P = w^H (H_1^H H_1 + H_2^H H_2 + \dots) w \tag{2}$$

where H_i is an estimated channel impulse response for BS# i . In regular SHO, the set of BS# i corresponds to the active set. With SSdT, the set of BS# i corresponds to the primary base station(s).

The UE feeds back to the UTRAN access point the information on which phase/power settings to use. Feedback Signaling Message (FSM) bits are transmitted in the portion of FBI field of uplink DPCCH slot(s) assigned to FB Mode Transmit Diversity, the FBI D field (see 25.211). Each message is of length $N_w = N_{po} + N_{ph}$ bits and its format is shown in the Figure 11. The transmission order of bits is from MSB to LSB, i.e. MSB is transmitted first. FSM_{po} and FSM_{ph} subfields are used to transmit the power and phase settings, respectively.

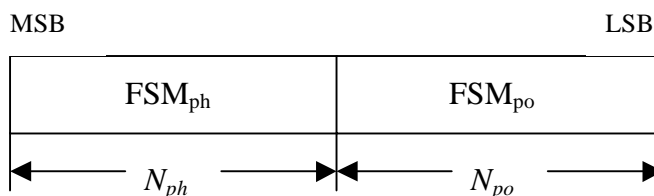

Figure 11: Format of feedback signaling message. FSM_{po} transmits the power setting and FSM_{ph} the phase setting.

The adjustments are made by the UTRAN Access Point at the beginning of the downlink DPCCH pilot field.

8.2 Feedback mode 1

In FB mode 1 UE first rotates the CPICH signal received from non-diversity antenna by $N \frac{p}{2} \text{ mod } p$. Next the UE calculates the phase adjustment as described in 8.1 and quantizes it into two values, 0, and π . If value is 0, a command '0' is send to Node B using the FSM_{ph} field. Correspondingly, if value is π , command '1' is send to Node B using thr FSM_{ph} field.

Due to rotation of the constellation at UE the Node B interprets the received commands according to Table 12 which shows the mapping between phase difference, f , and received feedback command for each UL slot. Note that no rotation is used (i.e. $N=0$) when calculating the value of feedback command for first slot of the UL frame.

Table 12. Feedback commands and corresponding phase differences, ϕ , for the slots of the UL radio frame.

FB Command	f														
	0	1	2	3	4	5	6	7	8	9	10	11	12	13	14
0	0	90	0	90	0	90	0	90	0	90	0	90	0	90	0
1	180	-90	180	-90	180	-90	180	-90	180	-90	180	-90	180	-90	180

The received phases are filtered by averaging over 2 slots. Conceptually, the filter must be implemented as shown in the Figure 12. There are two memory cells, one for each possible FB command. Whenever a new command is

received, the value of the corresponding memory cell is updated accordingly. After each update a new average is calculated. Algorithmically, the average is calculated as follows:

$$C = \frac{\sum_{i=0}^1 \sin(f_i)}{2} + j \frac{\sum_{i=0}^1 \cos(f_i)}{2} \quad (2)$$

where,

$$\begin{aligned} f_0 &\in \{0, 180\} \\ f_1 &\in \{90, -90\} \end{aligned} \quad (3)$$

The filtered phase difference between antennas, f_{Tx} , is then calculated from C. The weight vector, w , is:

$$w = \begin{bmatrix} w_1 \\ w_2 \end{bmatrix} = \begin{bmatrix} 1 \\ \cos f_{Tx} + j \sin f_{Tx} \end{bmatrix} \quad (4)$$

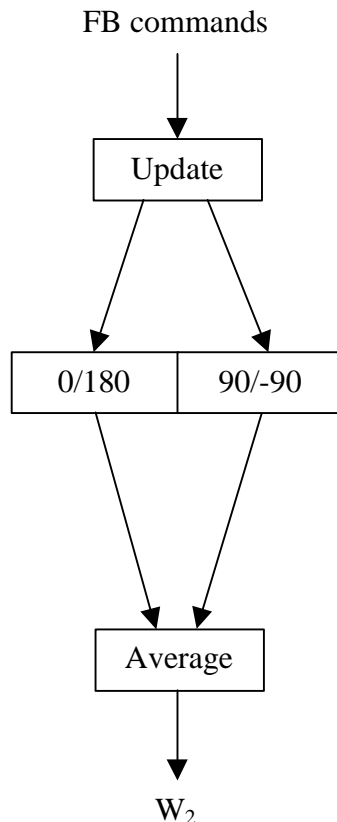

Figure 12. Conceptual description of the Node B filter for FB mode 1.

8.2.1 Mode 1 End of frame adjustment

In FB mode 1 at frame borders the command for slot 14 from previous frame and the command for slot 0 of the next frame update the same memory cell of the filter. Thus, at the border the average is calculated based on the command for slot 13 of the previous frame and the command for slot 0 of the next frame.

8.2.2 Mode 1 Normal Initialisation

For the first frame of transmission using closed loop mode 1 UE determines the feedback commands in a normal way and sends them to Node B.

At Node B the filter is initialized so that the memory cell for command 90/-90 degrees is always initialized to the value of 90 degrees.

8.2.3 Mode 1 Recovery from slotted mode

When recovering from the slotted mode no special actions are taken. The old values of the memory cells of the filter are used. When the first feedback command is received from UE the corresponding memory cell is updated and new average of w_2 is calculated to be used for the next downlink slot.

8.3 Feedback mode 2

In FB mode 2 there are 16 possible combinations of phase and amplitude adjustment from which the UE selects and transmits the FSM according to Table 13 and Table 14. No constellation rotation is done at UE. Similarly, no filtering of the received weights is performed at the Node B.

Table 13. FSM_{po} subfield of FB mode 2 signalling message.

FSM _{po}	Power_ant1	Power_ant2
0	0.2	0.8
1	0.8	0.2

Table 14. FSM_{ph} subfield of FB mode 2 signalling message.

FSM _{ph}	Phase difference between antennas (degrees)
000	180
001	-135
011	-90
010	-45
110	0
111	45
101	90
100	135

When $N_{po}=0$, equal power is applied to each antenna.

To obtain the best performance, progressive updating is performed at both the UE and the UTRAN Access point. Every slot time, the UE refines its choice of FSM, from the set of weights allowed given the previously transmitted bits of the FSM. This is shown in Figure 13.

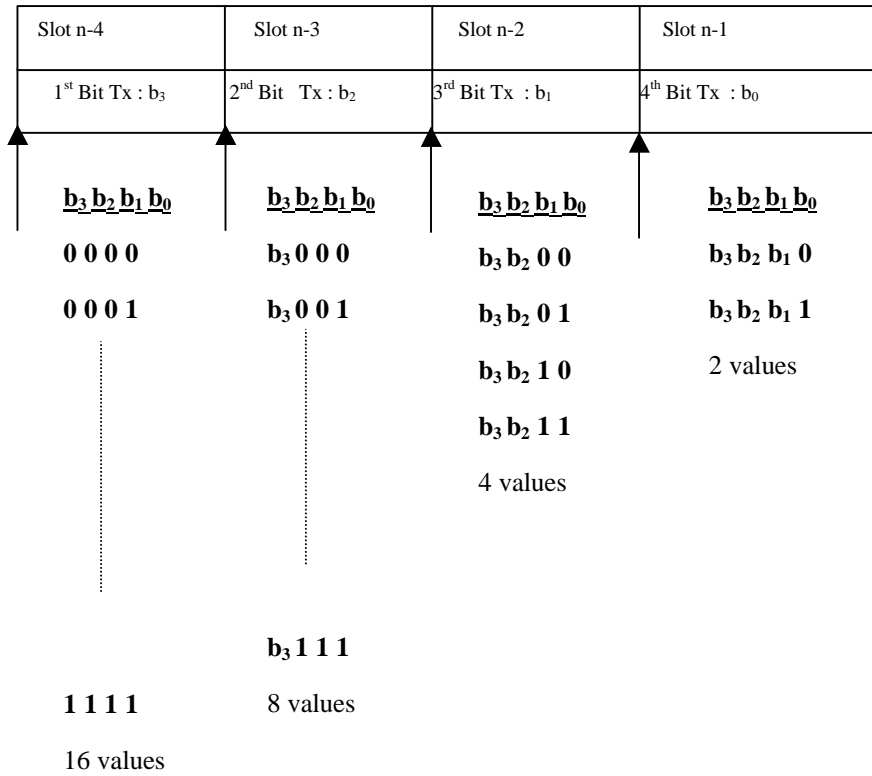

Figure 13. Profressive Refinement at the UE for FB mode 2.

Every slot time the UTRAN constructs the FSM from the most recently received bits for each position in the word. This is shown in Figure 14.

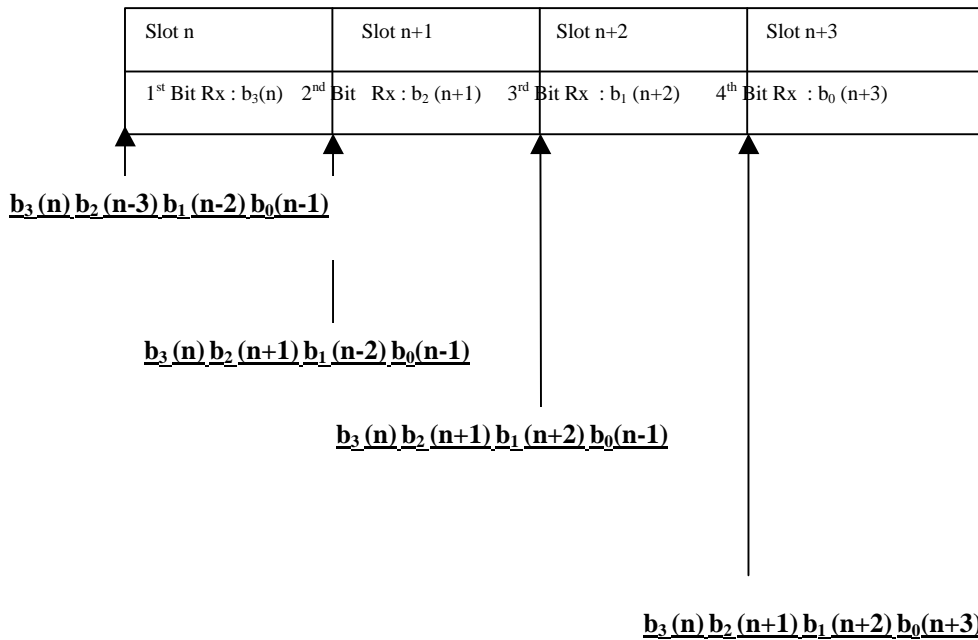

Figure 14. Profressive Refinement at the UTRAN Access Point for FB mode 2.

The weight vector, w , is then calculated as:

$$w = \begin{bmatrix} \sqrt{power_ant1} \\ \sqrt{power_ant2} \cdot \exp(jp \cdot phase_diff / 180) \end{bmatrix} \tag{6}$$

8.3.1 Mode 2 End of frame adjustment

The FSM must be wholly contained within a frame. To achieve this an adjustment is made to the last FSM in the frame where the UE only sends the FSM_{ph} subfield, and the Node B takes the amplitude bit FSM_{po} of the previous FSM.

8.3.2 Mode 2 Normal Initialisation

For the first frame of transmission using closed loop mode 2, the operation is as follows.

The UE starts sending the FSM message in slot 0 in the normal way, refining its choice of FSM in slots 1 to 3 from the set of weights allowed given the previously transmitted bits of the FSM.

During the reception of the first three FSM bits (that is before the full four bits are received), the UTRAN Access Point initialises its transmissions as follows. The power in both antennas is set to 0.5. The phase offset applied between the antennas is updated according to the number and value of FSM_{ph} bits received as given in Table 15.

Table 15.FSM_{ph} normal initialisation for FB mode 2.

FSM _{ph}	Phase difference between antennas (degrees)
- - -	180 (normal initialisation) or held from previous setting (slotted mode recovery)
0 - -	180
1 - -	0
0 0 -	180
0 1 -	-90
1 1 -	0
1 0 -	90
0 0 0	180
0 0 1	-135
0 1 1	-90
0 1 0	-45
1 1 0	0
1 1 1	45
1 0 1	90
1 0 0	135

This operation applies in both the soft handover and non soft handover cases.

8.3.3 Mode 2 Recovery from slotted mode

For recovery after slotted mode, UTRAN Access Point sets the power in both antennas to 0.5 until a FSM_{po} bit is received. Until the first FSM_{ph} bit is received and acted upon, UTRAN uses the phase offset which was applied before the transmission interruption (Table 15). Normal initialisation of FSM_{ph} (Table 15) occurs if the uplink signalling information resumes at the beginning of a FSM period (that is if signalling resumes in slots 0,4,8,12). If the uplink signalling does not resume at the beginning of a FSM period, the following operation is performed. In each of the remaining slots of the partial FSM period, and for the first slot of the next full FSM period, the UE sends the first (i.e. MSB) bit of the FSM_{ph} message, and at the UTRAN access point the phase offset applied between the antennas is updated according to the number and value of FSM_{ph} bits received as given in Table 16. Initialisation then continues with the transmission by the UE of the remaining FSM_{ph} bits and the UTRAN operation according to Table 15.

Table 16: FSM_{ph} subfield of FB mode 2 slotted mode recovery period

FSM _{ph}	Phase difference between antennas (degrees)
-	held from previous setting
0	180
1	0

9 Reverse link synchronous transmission

< Editor's note: This clause is only to be found in ARIB Volume 3. Some more discussion on this technique is probably needed, and for now the original text is kept. The physical layer procedures of RSTS needs to be identified and further refined and described in this clause. >

9.1 General

Reverse Link Synchronous Transmission (RSTS) can reduce reverse link intra-cell interference by means of making a node B receive orthogonalized signals from UEs in the cell. To orthogonalize receiving signals from UEs,

- the same scrambling code is allocated to all dedicated physical channels in the cell,
- different orthogonal spreading codes are allocated to all dedicated physical channels across all UEs in the cell, and
- the signal arrival time of each UE is adjusted.

The modulation scheme according to RSTS is described in *<update 3.2.4.2.1.2.2>*. The timing control procedures are described later in this section. RSTS is an alternative technology applicable for low mobility terminals. A system mainly accommodating low mobility terminals may adopt the RSTS.

The transmission time control is carried out by two steps. The first step is initial synchronization and the second is tracking.

- 1) Initial synchronization: Adjust transmission time through the initial timing control message over FACH
- 2) Tracking Process (Closed Loop Timing control): Adjust the transmission time through the Time Alignment Bit (TAB) over DTCH.

9.2 Initial synchronisation

- When the node B received signal from UE over RACH, node B measures the difference in time between the received timing and the reference time.
- The message for initial synchronization is delivered to UE via FACH.
- UE adjust its transmission time according to the message (the maximum amount of adjustments corresponds to the round trip delay of a cell).
- When the difference in time of initial measurement in the first step is not big, it is possible to skip these initial synchronization processes.

9.3 Tracking process

- Node B periodically compares the difference between the reference time and received signal timing from UE.
- When the received timing is earlier than the reference time, Time Alignment Bit (TAB) = "0". When this is

Since the timing control is carried out at much lower rate than TPC, TAB replaces the TPC bit every timing control period 20 msec. (In the exemplary embodiment, the timing control period equals to the frame length or multiples of it. In case of the example of timing control every frame, the first TPC bit of each frame is replaced by TAB)

- At the UE, soft decision on the TAB shall be performed, and when it is judged as "0", the transmission time shall be delayed by 1/4 (or 1/8) chip, whereas if it is judged as "1", the transmission time shall be advanced by 1/4 (or 1/8) chip.

9.4 Reference time

The reference time is set up at the starting point of forward-link frame plus the median value between minimum and maximum round trip delay within a cell. < Editor's note: How can one take the median of two values? >

Annex A (informative): Other procedures

A.3 Antenna verification

In FB mode 1, if channel estimates are taken from the Primary CCPCH, the performance will also suffer if the UE can not detect errors since the channel estimates will be taken for the incorrect phase settings. To mitigate this problem, antenna verification can be done, which can make use of antenna specific pilot patterns of the dedicated physical channel. The antenna verification can be implemented with several different algorithms. A straightforward algorithm can use a 4-hypothesis test per slot. Alternatively, a simplified beam former verification (SBV) requiring only a 2 hypothesis test per slot can be used. If we have orthogonal pilot patterns on the downlink DPCCH we can apply the SBV as follows:

Consider

$$2 \sum_{i=1}^{N_{path}} \frac{1}{s_i} \left\{ 2 \operatorname{Re}(g h_{2,i}^{(d)} h_{2,i}^{(p)*}) \right\} > \frac{\ln(\bar{p}(f_{Rx} = \mathbf{p}))}{\ln(\bar{p}(f_{Rx} = 0))}$$

then define the variable x_0 as, $x_0 = 0$ if the above inequality holds good and $x_0 = \pi$ otherwise. Similarly consider

$$-2 \sum_{i=1}^{N_{path}} \frac{1}{s_i} \left\{ 2 \operatorname{Im}(g h_{2,i}^{(d)} h_{2,i}^{(p)*}) \right\} > \frac{\ln(\bar{p}(f_{Rx} = -\frac{\mathbf{p}}{2}))}{\ln(\bar{p}(f_{Rx} = \frac{\mathbf{p}}{2}))}$$

then define the variable x_1 as, $x_1 = -\pi/2$ if the above inequality holds good and $x_1 = \pi/2$ otherwise. Whether x_0 or x_1 is to be calculated for each slot is given by the following table:

Slot	0	1	2	3	4	5	6	7	8	9	10	11	12	13	14
	x_0	x_1	x_0	x_1	x_0	x_1	x_0	x_1	x_0	x_1	x_0	x_1	x_0	x_1	x_0

The estimate for the transmitted phase is now obtained as:

$$\sin(f_{Tx}) + j \cos(f_{Tx}) = \frac{\sum_{i=0}^1 \sin(x_i)}{2} + j \frac{\sum_{i=0}^1 \cos(x_i)}{2}$$

where

the x_i values are used corresponding to the current slot and the next slot, except in the case of slot 14 wherein the slot 14 and slot 1 of the next frame values are used.

$h_{2,i}^{(p)}$ is the i 'th estimated channel tap of antenna 2 using the PCCPCH,

$h_{2,i}^{(d)}$ is the i 'th estimated channel tap of antenna 2 using the DPCCH,

γ^2 is the DPCH Pilot SNIR/ PCCPCH Pilot SNIR,

a_i are the elements of w .

S_i^2 is the noise plus interference on the i 'th path.

In normal operation the *a priori* probability for selected pilot pattern is assumed to be 96% (assuming there are 4% of errors in the feedback channel for power control and antenna selection).

Appendix A: Power Control Timing

<Editors note: The Power control timing described in this appendix should be seen as an example on how the control bits have to be placed in order to permit a short TPC delay. It seems appropriate to move this part later.>

In order to maximize the BTS-UE distance within which one-slot control delay is achieved, the frame timing of an uplink DPCH is delayed by 1024 chips from that of the corresponding downlink DPCH measured at the UE antenna.

Responding to a downlink TPC command, the UE shall change its uplink DPCH output power at the beginning of the first uplink pilot field after the TPC command reception. Responding to an uplink TPC command, BTS shall change its DPCH output power at the beginning of the next downlink pilot field after the reception of the whole TPC command. Note that in soft handover, the TPC command is sent over one slot when DPC_MODE is 0 and over three slots when DPC_MODE is 1. Note also that the delay from the uplink TPC command reception to the power change timing is not specified for BTS. The UE shall decide and send TPC commands on the uplink based on the downlink SIR measurement. The TPC command field on the uplink starts, when measured at the UE antenna, 512 chips after the end of the downlink pilot field. BTS shall decide and send TPC commands based on the uplink SIR measurement. However, the SIR measurement periods are not specified either for UE nor BTS.

Fig. A-1 illustrates an example of transmitter power control timings.

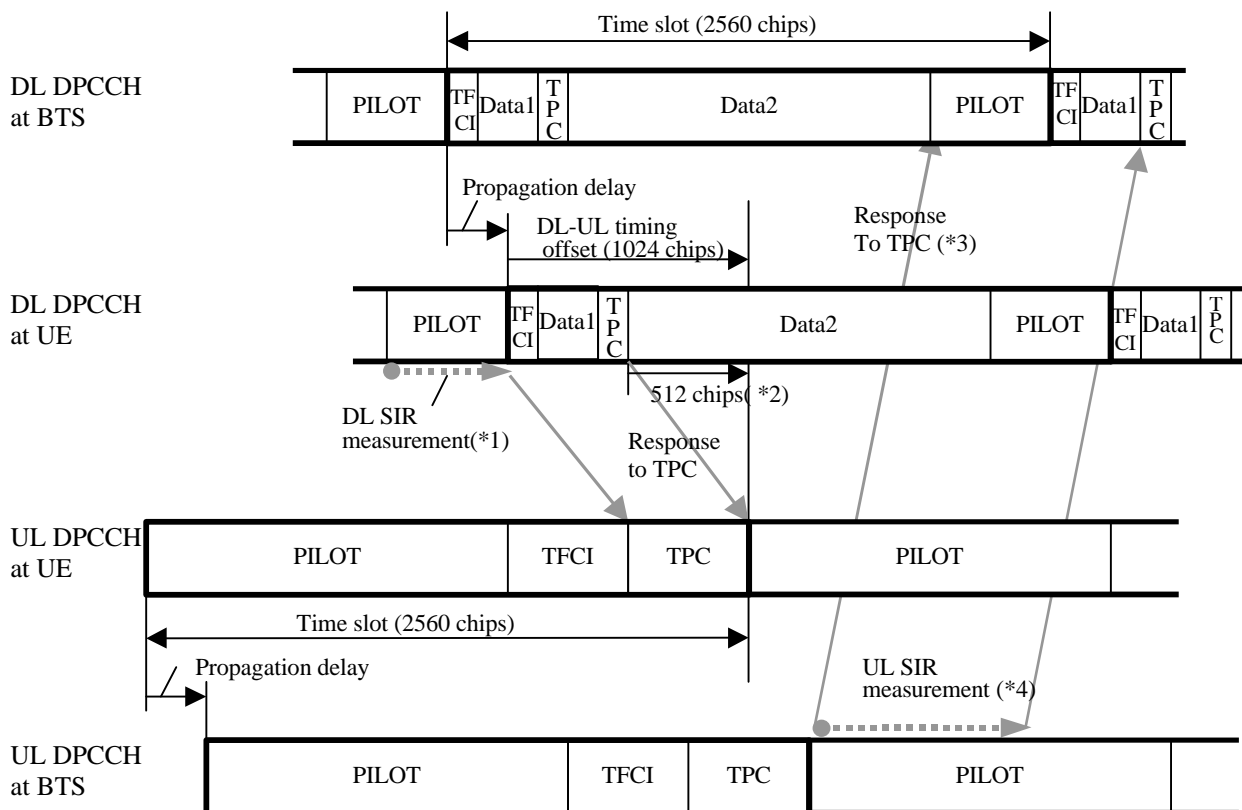

*1,4 The SIR measurement periods illustrated here are examples. Other ways of measurement are allowed to achieve accurate SIR estimation.

*2 Except the case of DL symbol rate=7.5ksp.

*3 If there is not enough time for BTS to respond to the TPC, the action can be delayed until the next slot.

Fig. A-1 Transmitter power control Timing

History

Document history		
V0.0.1	1999-02-12	Document created based on ETSI XX.07 V1.3.1 and ARIB Volume 3 ver. 1.0.
V0.1.0	1999-02-26	Version approved by WG1#2. The changes agreed at the meeting to incorporate e.g. ad hoc conclusions not yet included.
V1.0.0	1999-03-04	Version approved by TSG RAN. The changes agreed at the WG1#2 meeting to incorporate e.g. ad hoc conclusions not yet included.
V1.0.1	1999-03-17	Include adhoc conclusions in WG1#2
V1.0.2	1999-03-24	Include adhoc conclusions in WG1#3
V1.1.0	1999-03-25	Version approved by WG1#3.
V2.0.0	1999-04-20	Version approved by WG1#4
V1.0.0	1999-04-23	Version approved by TSG RAN#3
V1.1.0	1999-06-04	Version approved by WG1#5
V1.2.0	1999-08-30	Version approved by WG1#7
V1.3.0	1999-09-03	Version approved by WG1#7
<p>Editors for 3GPP TSG RAN S1.14 are:</p> <p>Takehiro Nakamura NTT DoCoMo R&D Headquarters Tel: +81 468 40 31 90 Mobile: +81 30 20 05 542 Fax: +81 468 40 38 40 E-mail: takehiro@wsp.yrp.nttdocomo.co.jp</p> <p>This document is written in Microsoft Word 97.</p>		