

Agenda item :

Title : SSdT specification update (TS25.214)

Source : NEC and T-Modus

Document for: Discussion

1. Overview

RAN-WG2 and WG3 are respectively standardizing the specifications relating to SSdT. From the up-to-date agreements within the respective WG, some parts of the L1 specifications for SSdT need modifications. The change to be required is that the assignment of temp ID to each active cell is carried out by the network itself, but not carried out by the way of entry position described in the current specification. This paper presents the modified proposed text that is updated so as to meet this change. The proposed text also includes the change regarding the addition of two more temp IDs. The new set containing 8 CWs can maintain the minimum Hamming distance that was achieved by the previous 6 CWs set.

Proposed text change (TS25.214)

5.2.3.5 Site selection diversity transmit power control

< Editor's note: ~~In general, the text describing SSdT should be checked to identify L1 and L23 issues separately. Some contents should perhaps be moved to WG2 documentation. The text could also be made more specification-like. For the time being the text is kept with some cosmetic and language related changes.~~ >

5.2.3.5.1 General

Site selection diversity transmit power control (SSdT) is an optional macro diversity method in soft handover mode.

Operation is summarised as follows. The UE selects one of the cells from its active set to be 'primary', all other cells are classed as 'non primary'. The main objective is to transmit on the downlink from the best cell, thus reducing the interference caused by multiple transmissions in a soft handover mode. A second objective is to achieve fast site selection without network intervention, thus maintaining the advantage of the soft handover. In order to select a primary cell, each cell is assigned a temporary identification and UE periodically informs a primary cell identification to the connecting cells. The non-primary cells selected by UE switch off the transmission power. The primary cell identity code is delivered via uplink FBI field.

5.2.3.5.2 Initiation of SSdT

The SSdT is initiated by the network, based on the soft handover active cell set. The cell and UE are subsequently informed by the network that the SSdT option has been

activated during the current soft handover period. Otherwise, TPC is operated in the ordinary mode, i.e. each cell controls its power in accordance with an uplink TPC command by the way described in 5.2.3.2. The temporary cell identification assignment (i.e. ID code assignment) is ~~based on the order of active set~~carried out by network which is communicated to all the active cells and the UE.

~~A cell receiving the active list is capable of recognising its entry position in the list from which it can determine its own ID code. Similarly, UE upon receiving the active list can determine the ID code of each of the active cells according to the order of the cell entries in the list. Therefore the network and UE has the same association between the ID codes and cells.~~ After the activation of the SSDT and the subsequent UE acknowledgements, the UE starts to send the “primary” cell ID code, described in the following subclauses. Following a successful activation of SSDT and reception of the UE acknowledgement, the active cells start detecting the “primary” cell ID information.

5.2.3.5.3 Settings of temporary cell identification

Each cell is given a temporary identification during SSDT and the identification is utilised as site selection signal. In the following, the temporary identification is referred to as “ID”.

5.2.3.5.3.1 Definition of temporary cell identification

The ID is given a binary bit sequence. There are three different lengths of coded ID available denoted as "long", "medium" and "short". The network decides which length of coded ID is used and notifies it to both UE and cells by higher layer signaling message in the initiation of SSDT. Settings of ID codes for 1-bit FBI are exhibited in Table 1 and Table 2, respectively.

Table 1 Settings of ID codes for 1 bit FBI

ID label	ID code		
	"long"	"medium"	"short"
a	0000000000000000	0000000(0)	00000
b	1111111111111111	1111111(1)	11111
c	0000000011111111	0000111(1)	00011
d	1111111100000000	1111000(0)	11100
e	0000111111110000	0011110(0)	00110
f	1111000000001111	1100001(1)	11001
<u>g</u>	<u>001111000011110</u>	<u>0110011(0)</u>	<u>01010</u>
<u>h</u>	<u>110000111100001</u>	<u>1001100(1)</u>	<u>10101</u>

Table 2 Settings of ID codes for 2 bit FBI

ID label	ID code (Column and Row denote slot position and FBI-bit position.)		
	<u>“long”</u>	<u>“medium”</u>	<u>“short”</u>
	a	0000000(0) 0000000(0)	000(0) 000(0)
b	1111111(1) 1111111(1)	111(1) 111(1)	111 111
c	0000000(0) 1111111(1)	000(0) 111(1)	000 111
d	1111111(1) 0000000(0)	111(1) 000(0)	111 000
e	0000111(1) 1111000(0)	001(1) 110(0)	001 100
f	1111000(0) 0000111(1)	110(0) 001(1)	110 011
g	<u>0011110(0)</u> <u>0011110(0)</u>	<u>011(0)</u> <u>011(0)</u>	<u>010</u> <u>010</u>
h	<u>1100001(1)</u> <u>1100001(1)</u>	<u>100(1)</u> <u>100(1)</u>	<u>101</u> <u>101</u>

ID must be terminated within a frame. If FBI space for sending a given ID cannot be obtained within a frame, hence if the entire ID is not transmitted within a frame but must be split over two frames, the last bit(s) of the ID is(are) punctured. The relating bit(s) to be punctured are shown with brackets in Table 1 and Table 2.

5.2.3.5.3.2 Assignment of ID to each cell

The “ID” word assignment to each cell is carried out by network and the assignment result is informed to active cells and UE. Every time that the active list is changed, it shall be informed to all active cells and UE via the higher layer signaling. The “ID” word assignment is based on the entry position in the active list, which is compiled and communicated to all active cells and UE.

Table 3: ID assignment example

Number of cells in active set	ID label assignment for each cell					
	<u>Entry position in active set</u> Cell					
	<u>index</u>					
	1	2	3	4	5	6
1	a					
2	a	b				
3	a	b	c			
4	a	b	c	d		
5	a	b	c	d	e	
6	a	b	c	d	e	F

5.2.3.5.3.3 ~~Notification of ID assignment change~~

~~Every time that the active list is changed, it is updated and communicated to all active cells and UE.~~

5.2.3.5.4 TPC procedure in UE

The TPC procedure of the UE in SSdT is identical to that described in subclause

5.2.3.2.

5.2.3.5.5 Selection of primary cell

The UE selects a primary cell periodically by measuring reception levels of common pilots transmitted by the active cells. The cell with the highest pilot power is detected as a primary cell.

5.2.3.5.6 Delivery of primary cell ID

The UE periodically sends the ID code of the primary cell via portion of the uplink FBI field assigned for SSDT use (FBI S field). A cell recognises its state as non-primary if the following two conditions are fulfilled simultaneously:

- the received primary ID code does not match with the own ID code,
- and the received uplink signal quality satisfies a quality threshold, Q_{th} , a parameter defined by the network.

Otherwise the cell recognises its state as primary.

At the UE, the primary ID code to be sent to the cells is segmented into a number of portions. These portions are distributed in the uplink FBI S-field. The cell in SSDT collects the distributed portions of the primary ID code and then detects the transmitted ID. Period of primary cell update depends on the settings of code length and the number of FBI bits assigned for SSDT use as shown in Table 4

Table 4 Period of primary cell update

code length	The number of FBI bits per slot assigned for SSDT	
	1	2
"long"	1 update per frame	2 updates per frame
"medium"	2 updates per frame	4 updates per frame
"short"	3 updates per frame	5 updates per frame

5.2.3.5.7 TPC procedure in the network

In SSDT, a non-primary cell can switch off its output power (i.e. no transmissions).

5.2.3.5.7.1 Management of multiple transmission power levels

The cell manages two downlink transmission power levels, P1, and P2, for each UE in soft handover. Power level P1 keeps track of the minimum downlink power required, if the cell is chosen as the primary cell. The cell updates P1 regardless of the selected state (primary or non-primary). The data fields from non-primary cells are transmitted at power level P2. When a cell is selected by the UE as the primary cell, P2 is set to P1, otherwise the cell maintains P2 at the minimum transmit level (i.e. data fields power off). P1 and P2, expressed in dBm, are updated in accordance with TPC commands from the UE as shown in Table 5. The two power settings P1 and P2 are maintained within the power control dynamic range.

Table 5: Updating of P1 and P2

State of cell	TPC signal	P1	P2
non primary	down	$P1 - \Delta_{TPC}$	Switched off
	up	$P1 + \Delta_{TPC}$	Switched off
primary	down	$P1 - \Delta_{TPC}$	= P1
	up	$P1 + \Delta_{TPC}$	= P1

Δ_{TPC} is defined in subclause 5.2.3.2. < Editor's note: Maybe it is not defined in standard, see comment in 5.2.3.2. > No regulation of initial value of P1 and P2 is given.

5.2.3.5.7.2 Power setting of the downlink Dedicated Physical Channel

The downlink Dedicated Physical Channel is partitioned into 5 portions as shown in Figure 9 of S25.211. Power setting of each portion during SSdT is depicted in Figure 1.

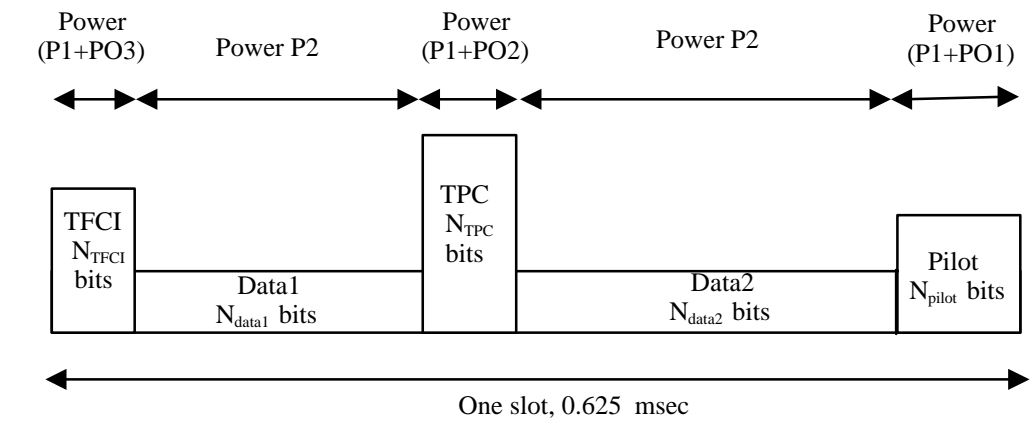

Figure 1: Power setting of the downlink Dedicated Physical Channel

Transmission power of the TPC and TFI portions are always set to P1, in order to detect the control information at the UE with high reliability.

5.2.3.5.8 Termination of SSdT

The decision to terminate the SSdT is made by the network, ~~based on the UE reported received signal strength levels of all the active and candidate list pilots.~~ The termination request should be informed by the network to both cells and UE The signaling methods regarding SSdT termination are described in the higher layer specifications in detail. in the same way as soft handoff termination process.