

TSG-RAN Working Group1 meeting #7
Hanover, Germany, August 1999

Source: Siemens
Title: Inclusion of a clause for detailed channel coding
Document for: Decision

Introduction

Following the approach for FDD to put some examples [1] for specific transmission schemes and data rates into the specification and in accordance to discussions during the WG1 meeting #6, this contribution shows service mapping examples for TDD. These diagrams only demonstrate some possibilities to clarify the minimum requirements for a UE and to give an overview for the handling of the resources. We propose to place these figures into the annex of the specification TS25.222 for informative purposes.

Purpose of the proposal

The purpose of this document is to clarify layer 1 transmission capabilities for other WG's and to give a hint for the minimum requirements for a UE, supporting the proposed data rates (e.g. number of TS and codes). Moreover it might prevent misunderstanding regarding ambiguous or insufficient description of specific transmission schemes or services.

Service mapping in TDD

For the downlink we propose to use multicode with spreading factor SF16 and for the uplink the use of variable spreading and at most two codes with spreading factors SF2 to SF16. We also propose to use SF1 in both downlink and uplink, if the interference conditions are favourable and the UE supports this. The reasons are listed below:

Multicode in the downlink

- Multicode detection and SF16 must be supported in the UE in any case, since the CCPCH is always transmitted with SF16
- SF1 is only possible, if interference conditions are favourable and the UE supports this
- The UE doesn't have to blindly detect multiple spreading factors, so the complexity of the mobile decreases

Variable Spreading in the uplink

- The peak to average ratio for the terminal decreases, if only one or at most two codes have to be transmitted, so the design of the power amplifier for the terminal becomes less complex
- SF8 and SF16 must be supported in the UE in any case for the PRACH, so it seems obvious to allow variable spreading in the uplink
- To achieve a better granularity of data rate, at most two codes with different spreading factors should be supported
- SF1 is only possible, if interference conditions are favourable and the UE supports this

Guidelines for Handling of Different User Data Rates

Downlink:

If the requested user data rate increases:

1. allocate additional codes within the same timeslot until 9 codes are allocated
2. allocate additional timeslots until 12 timeslots are allocated
3. use SF1 in all 12 timeslots

As an option:

SF1 may be used even if less than 12 TS are allocated if the interference conditions are favourable and the UE supports this.

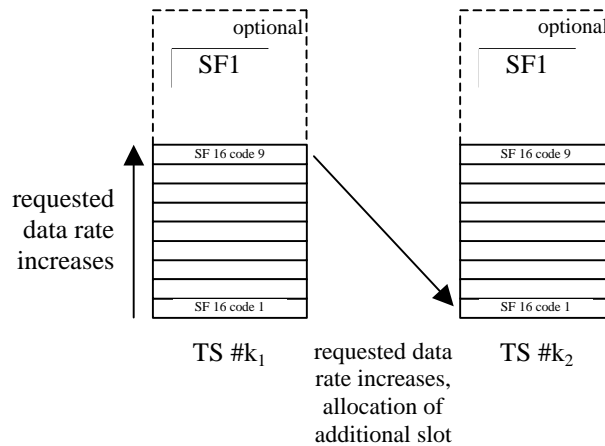

Figure 1: allocation of resources depending on requested data rate in Downlink

Uplink:

If the requested user data rate increases:

1. Reduce the spreading factor in discrete steps down to SF2.
If necessary, allocate at most one additional code with a higher spreading factor within the same timeslot to achieve a better granularity for data rates.
2. allocate additional timeslot until 12 timeslots are allocated
3. use SF1 in all 12 timeslots

As an option:

SF1 may be used even if less than 12 TS are allocated if the interference conditions are favourable and the UE supports this.

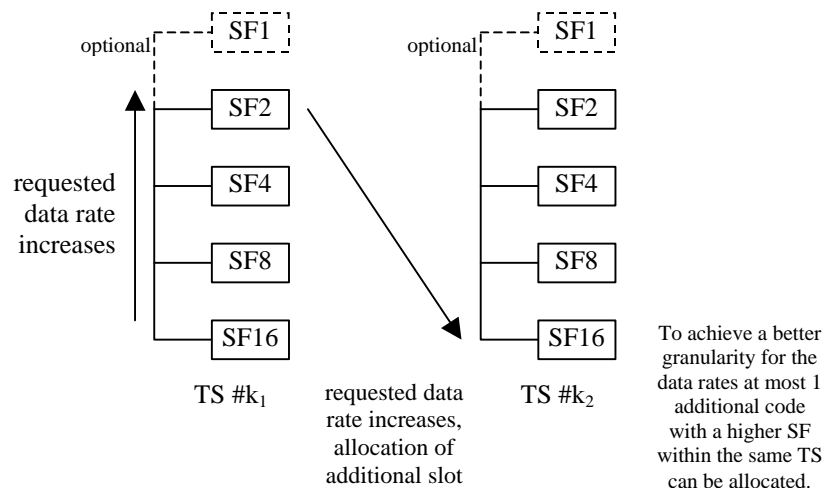

Figure 2: allocation of resources depending on requested data rate in Uplink

Examples for specific data rates

The following examples are proposed:

data rate	Uplink			Downlink		
	# of TS	TS content	burst type	# of TS	TS content	burst type
8 kbps	1	1 code SF16	1	1	1 code SF16	1
12.2 kbps	1	1 code SF8	1	1	2 codes SF16	1
64 kbps	1	1 code SF4 + 1 code SF16	1	1	5 codes SF16	1
144 kbps	1	1 code SF2 + 1 code SF16	2	1	9 codes SF16	2
384 kbps	3	1 code SF2	2	3	8 codes SF16	2
2 Mbps	12	1 code SF1	2	12	1 code SF1	2

Please note that any other mapping is possible, too. Here only some examples are shown to give a hint for minimum requirements.

The proposed figures demonstrate the mapping of the services to the radio frames. Although interleaving over 20ms ... 80ms is possible, we demonstrate the 20ms interleaving period because this seems to be the worst case regarding the effective code rate, since the overhead per user data block like CRC and Termination bits decreases with increased interleaving time. The DCCH is interleaved over 40ms.

Conclusion

This document has shown some examples for service mapping, we propose to place these figures into the annex of the specification TS25.222 for informative purposes. These mappings are only examples and show only one of many possible ways to do it. We proposed a rule for allocation of resources which should be put into TS25.222.

Textproposal for 25.222

The following pages are showing the proposed text for inclusion in specification document TS25.222 as informative annex.

References

- [1] 3GPP TSG RAN WG1 Tdoc R1-99648, Inclusion of a clause for detailed channel coding
- [2] 3GPP TSG RAN specification TS25.222, Multiplexing and channel coding (TDD)

Annex B (informative)

B.1 Guidelines for Handling of Different User Data Rates

In this informative Annex guidelines for handling of different user data rates are shown.

Downlink:

If the requested user data rate increases:

1. allocate additional codes within the same timeslot until 9 codes are allocated
2. allocate additional timeslots until 12 timeslots are allocated
3. use SF1 in all 12 timeslots

As an option:

SF1 may be used even if less than 12 TS are allocated if the interference conditions are favourable and the UE supports this.

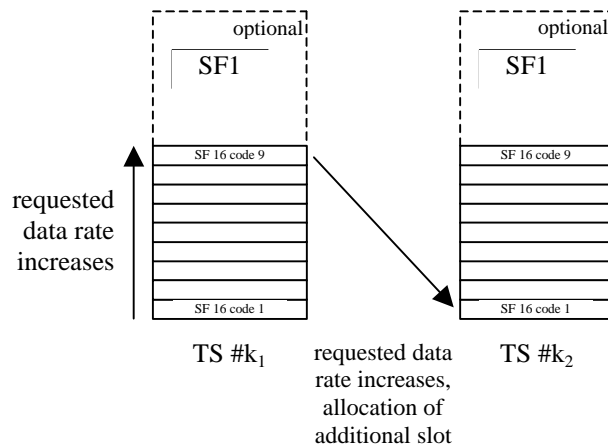

Figure 1: allocation of resources depending on requested data rate in Downlink

Uplink:

If the requested user data rate increases:

1. Reduce the spreading factor in discrete steps down to SF2.
If necessary, allocate at most one additional code with a higher spreading factor within the same timeslot to achieve a better granularity for data rates.
2. allocate additional timeslot until 12 timeslots are allocated
3. use SF1 in all 12 timeslots

As an option:

SF1 may be used even if less than 12 TS are allocated if the interference conditions are favourable and the UE supports this.

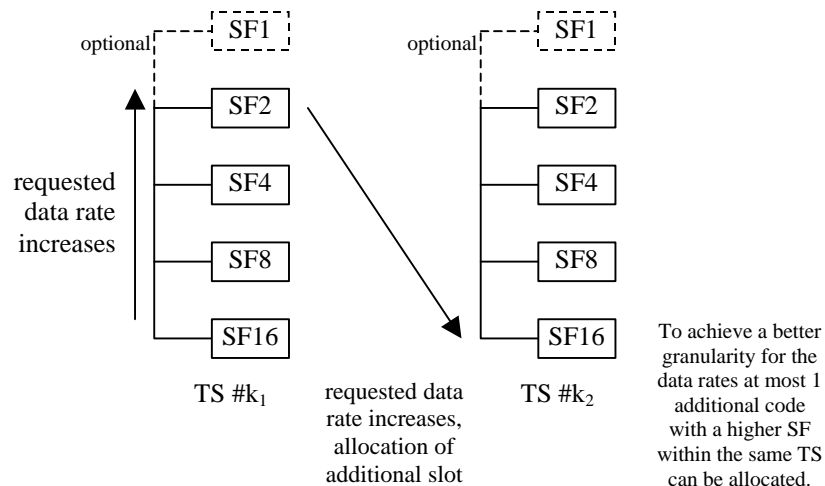

Figure 2: allocation of resources depending on requested data rate in Uplink

B.2 Examples for Detailed Channel Coding

The figures show some examples for channel coding and mapping to resource units. In both uplink and downlink we propose a 2 kbps channel for higher layer signalling, like control information and header. The different examples are in line with the figure 6.1 in the TS25.222 specification and show some examples for detailed channel coding and multiplexing structure for uplink and downlink for different data rates.

Example for BCH

[mapped to 1 code SF16]

Parameter	
Information data rate	11 kbps
RU's allocated	1 RU
Midamble	512 chips
Interleaving	20 ms
Power control	0 bit
TFCI	0 bit
Puncturing level at Code rate 1/2 :	0%

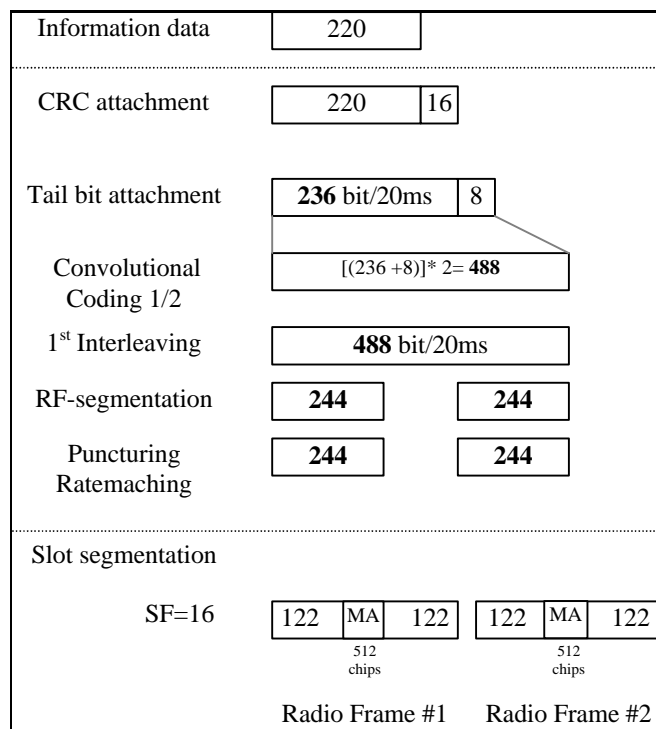

Example for 8 kbps data rate for Uplink

[mapped to 1 code SF=16]

Parameter	
Information data rate	8 kbps
RU's allocated	1 RU
Midamble	512 chips
Interleaving	20 ms
Power control	2 Bit/user
TFCI	16 Bit/user
Inband signalling DCCH	2 kbps
Puncturing level at Code rate 1/2 : DCH / DCCH	10% / -1%

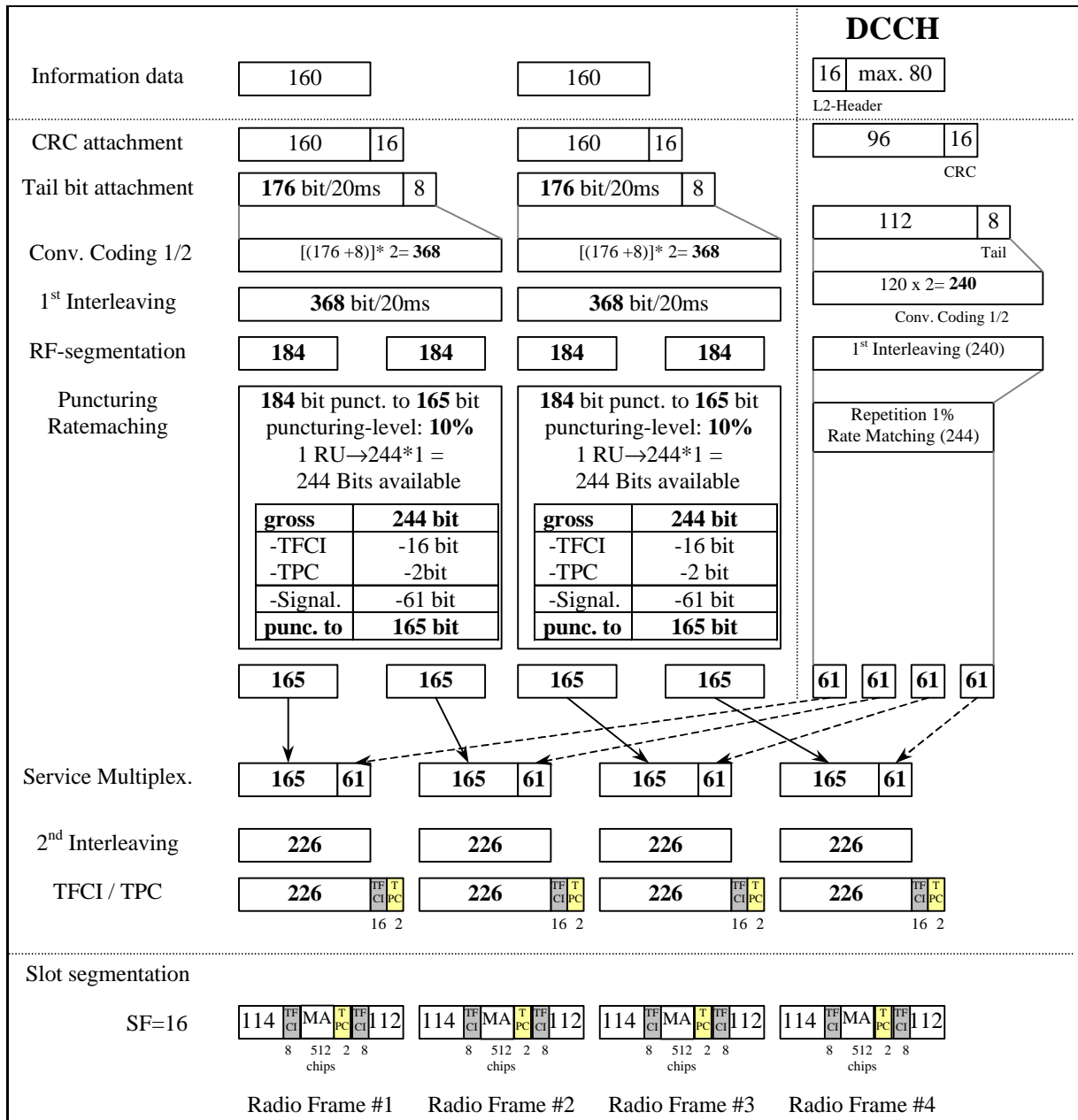

Example for 12.2 kbps data rate for Uplink

[mapped to 1 code SF=8]

Parameter	
Information data rate	12.2 kbps
RU's allocated	2 RU
Midamble	512 chips
Interleaving	20 ms
Power control	2 Bit/user
TFCI	16 Bit/user
Inband signalling DCCH	2 kbps
Puncturing level at Code rate 1/3 : DCH / DCCH	5% / 0%

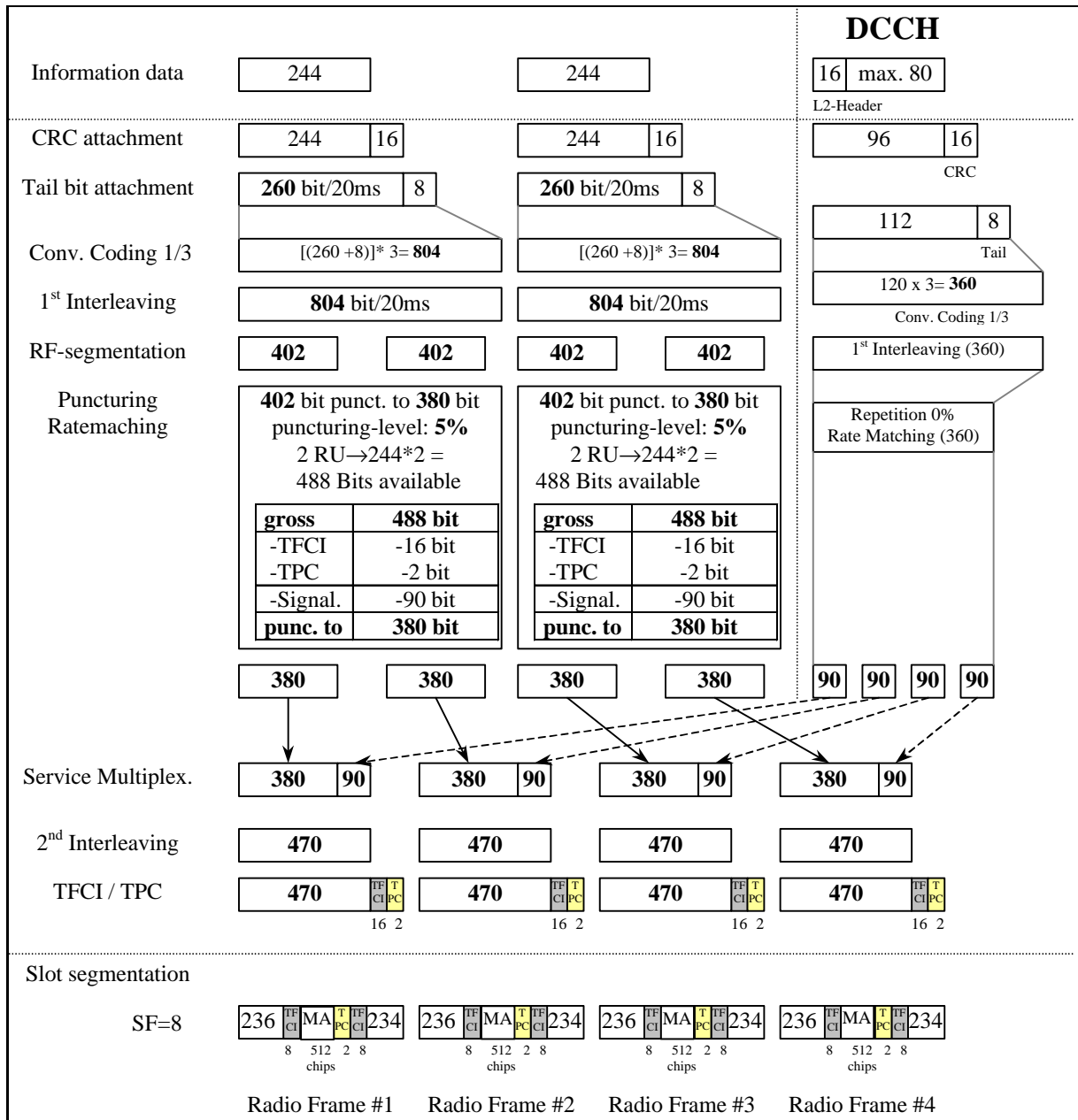

Example for 64 kbps data rate for Uplink

[mapped to 1 code SF=4 and 1 code SF=16]

Parameter	
Information data rate	64 kbps
RU's allocated	1 SF4 + 1 SF16 = 5RU
Midamble	512 chips
Interleaving	20 ms
Power control	2 Bit/user
TFCI	16 Bit/user
Inband signalling DCCH	2 kbps
Puncturing level at Code rate 1/2 : DCH / DCCH	11.8% / 10%

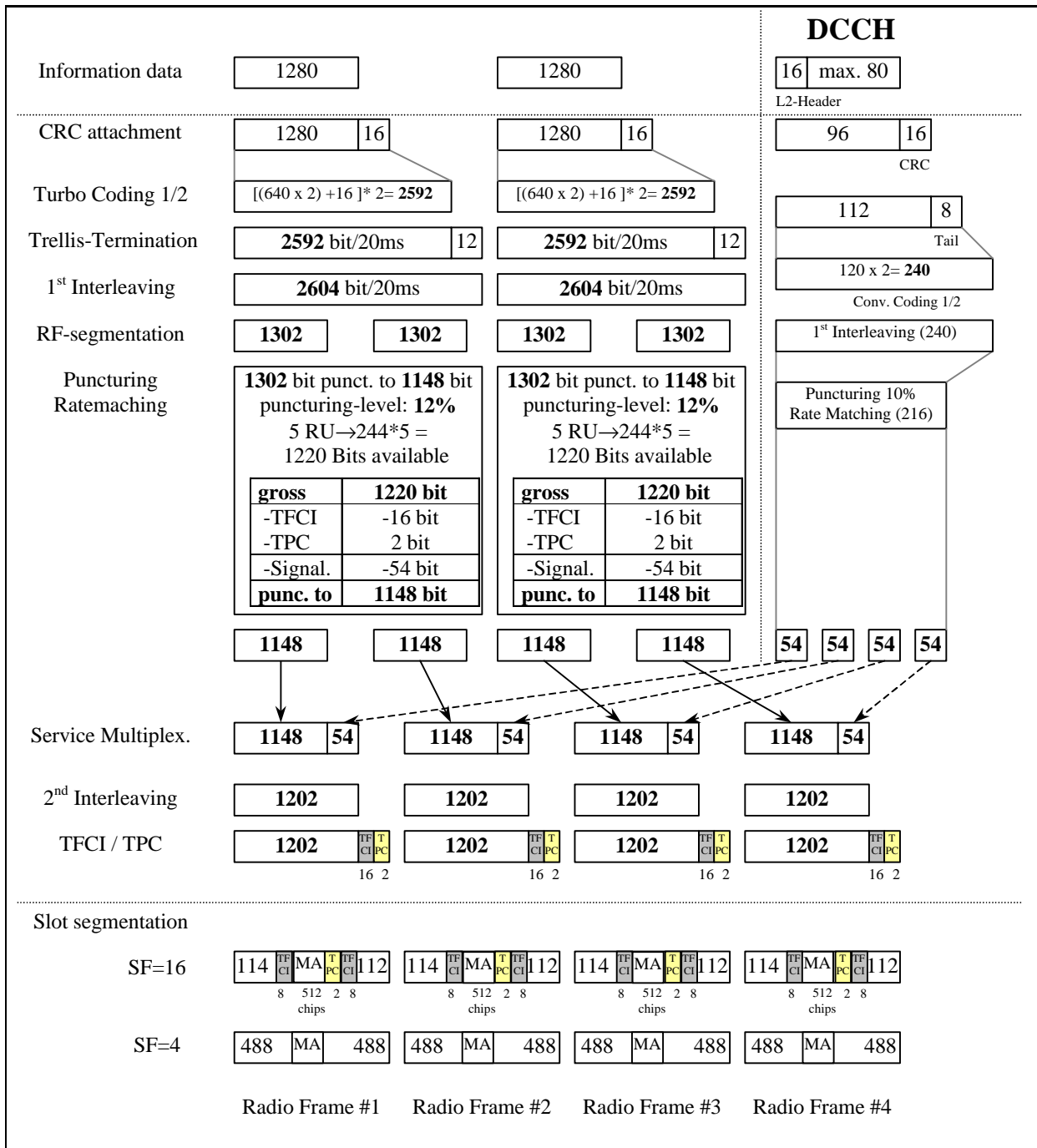

Example for 144 kbps data rate for Uplink

[mapped to 1 code SF=2 and 1 code SF=16]

Parameter	
Information data rate	144 kbps
RU's allocated	1 SF2 + 1 SF16 = 9RU
Midamble	256 chips
Interleaving	20 ms
Power control	2 Bit/user
TFCI	16 Bit/user
Inband signalling DCCH	2 kbps
Puncturing level at Code rate 1/2 : DCH / DCCH	16.7% / 16.6%

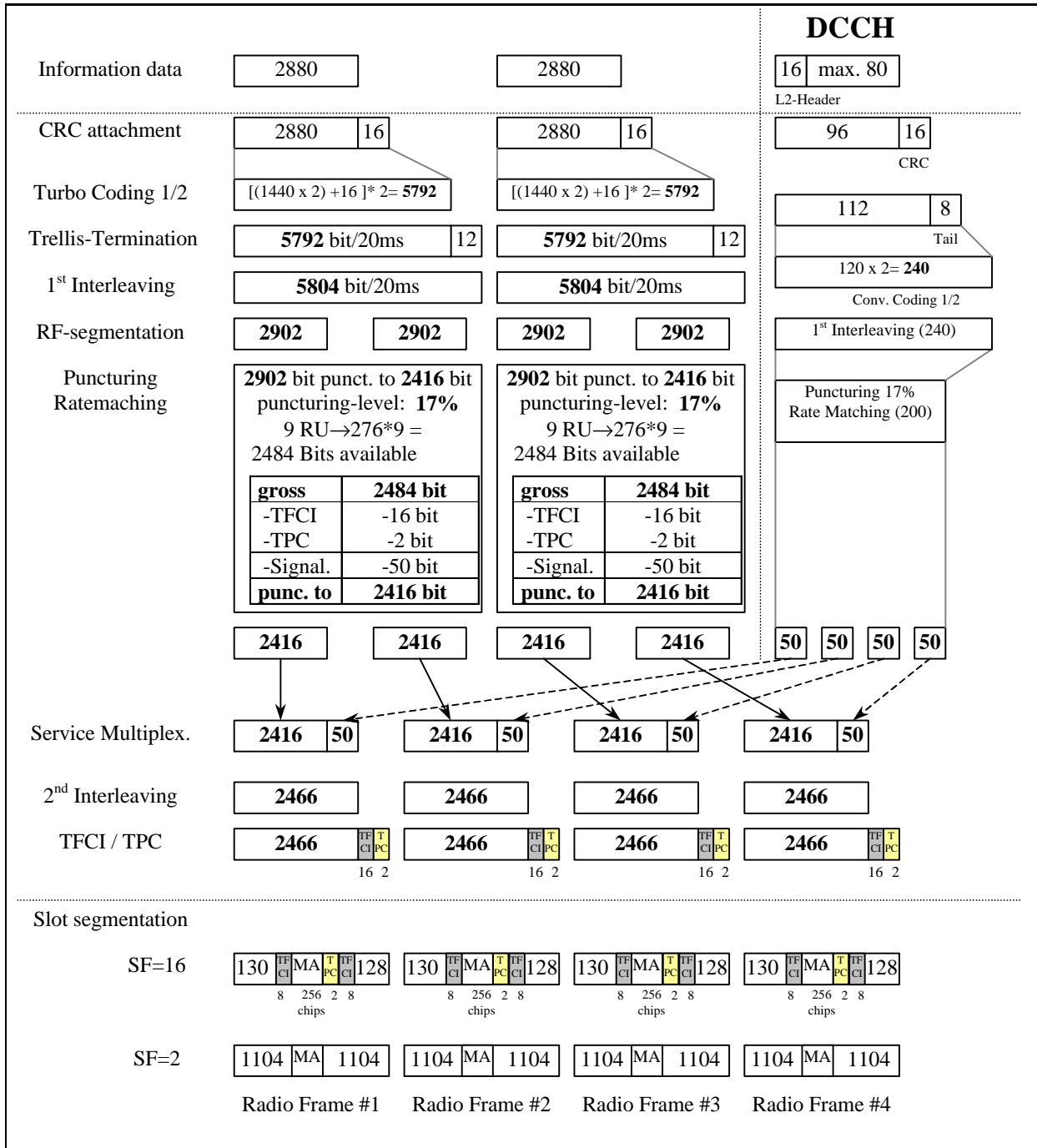

Example for 384 kbps data rate for Uplink

[mapped to 3 TS with 1 code SF=2 in each]

Parameter	
Information data rate	384 kbps
RU's allocated	8*3TS = 24RU
Midamble	256 chips
Interleaving	20 ms
Power control	2 Bit/user
TFCI	16 Bit/user
Inband signalling DCCH	2 kbps
Puncturing level at Code rate 1/2 : DCH / DCCH	15.1% / 15.3%

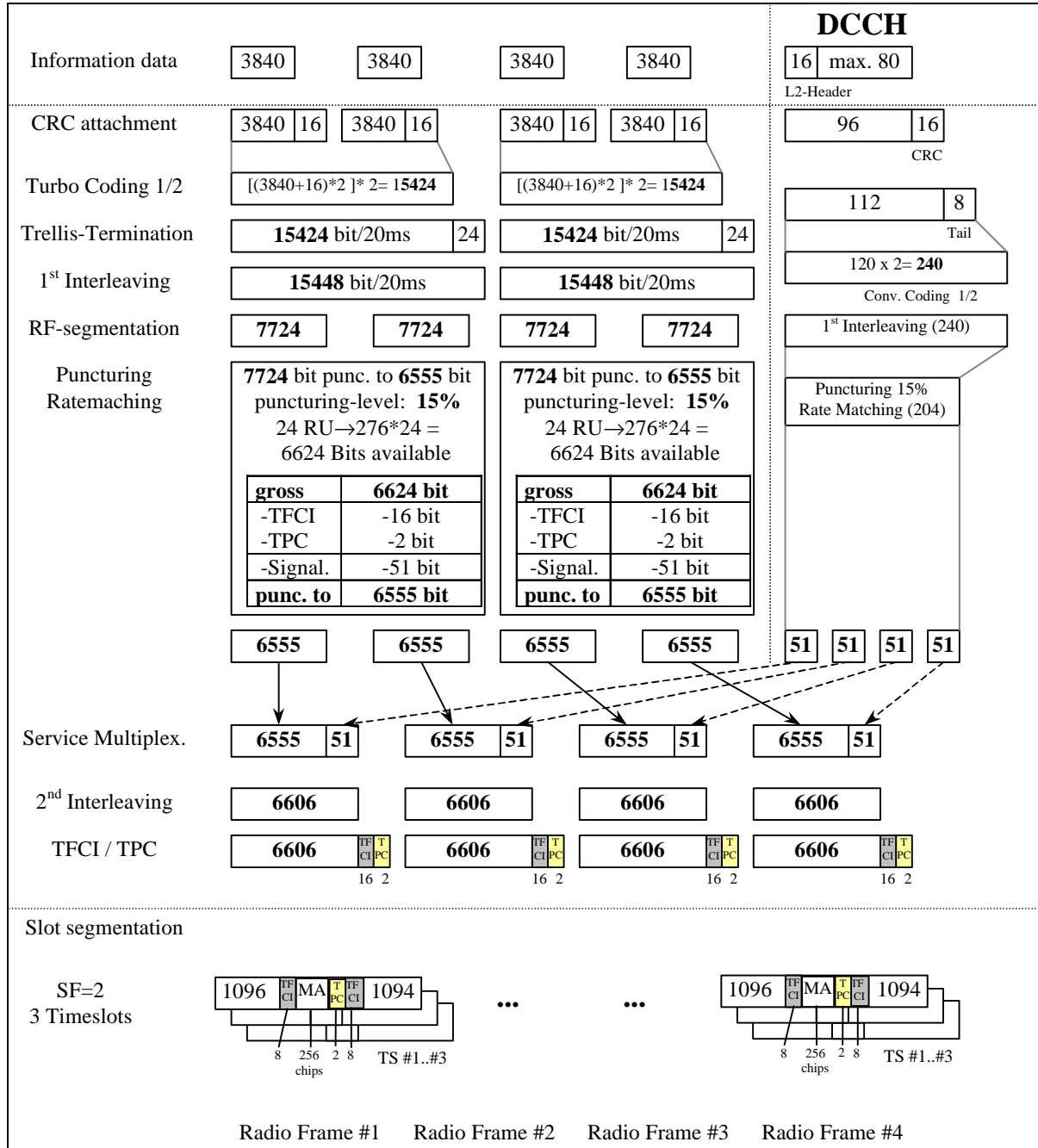

Example for 2048 kbps data rate for Uplink

[mapped to 12 TS with 1 code SF=1 in each]

Parameter	
Information data rate	2048 kbps
RU's allocated	16*12TS = 192RU
Midamble	256 chips
Interleaving	20 ms
Power control	2 Bit/user
TFCI	16 Bit/user
Inband signalling DCCH	2 kbps
Puncturing level at Code rate 1/3 : DCH / DCCH	14.3% / 0%

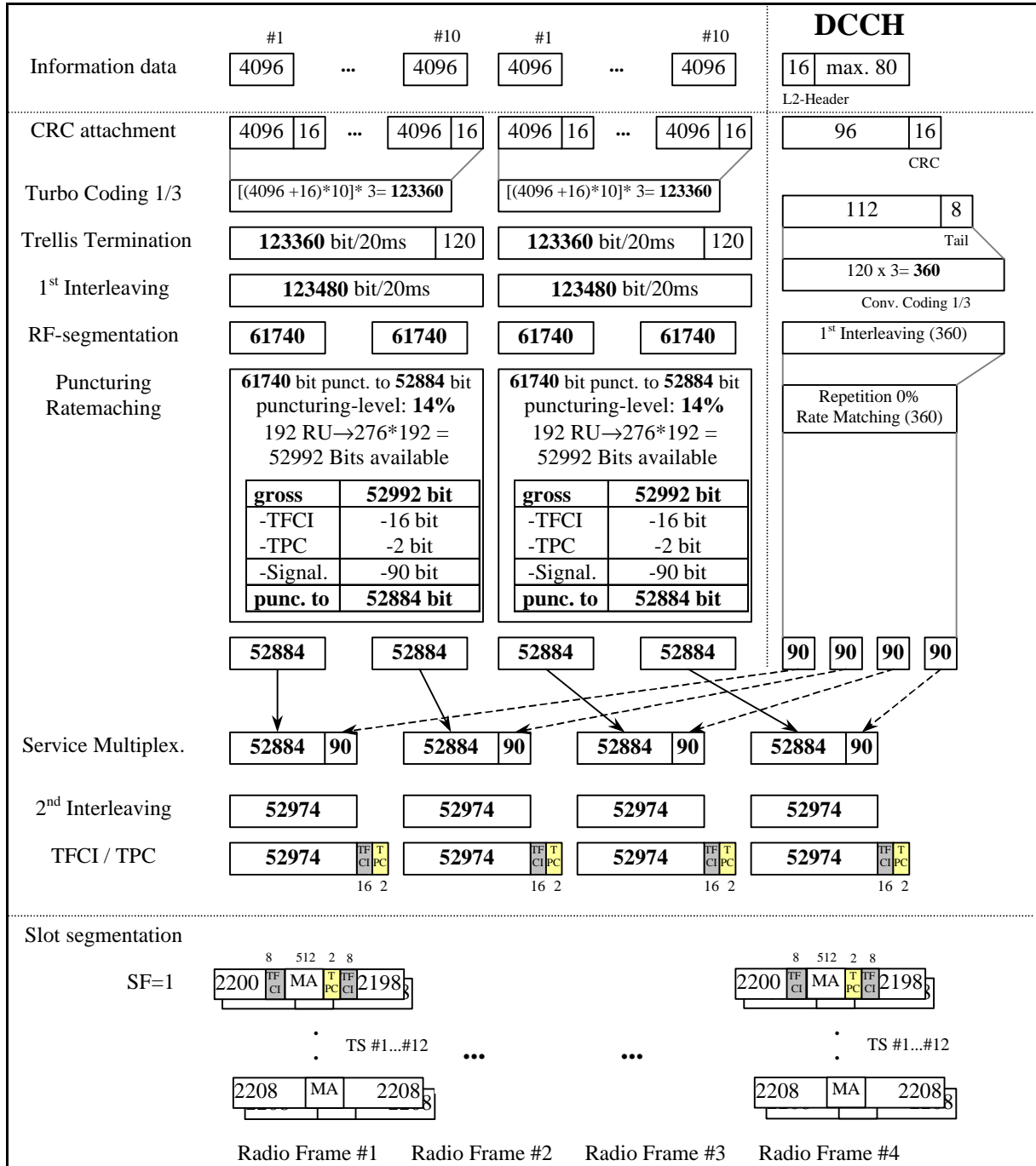

Example for 8 kbps data rate for Downlink

[mapped to 1 code SF=16]

Parameter	
Information data rate	8 kbps
RU's allocated	1 RU
Midamble	512 chips
Interleaving	20 ms
Power control	0 Bit/user
TFCI	16 Bit/user
Inband signalling DCCH	2 kbps
Puncturing level at Code rate 1/2 : DCH / DCCH	9% / -1%

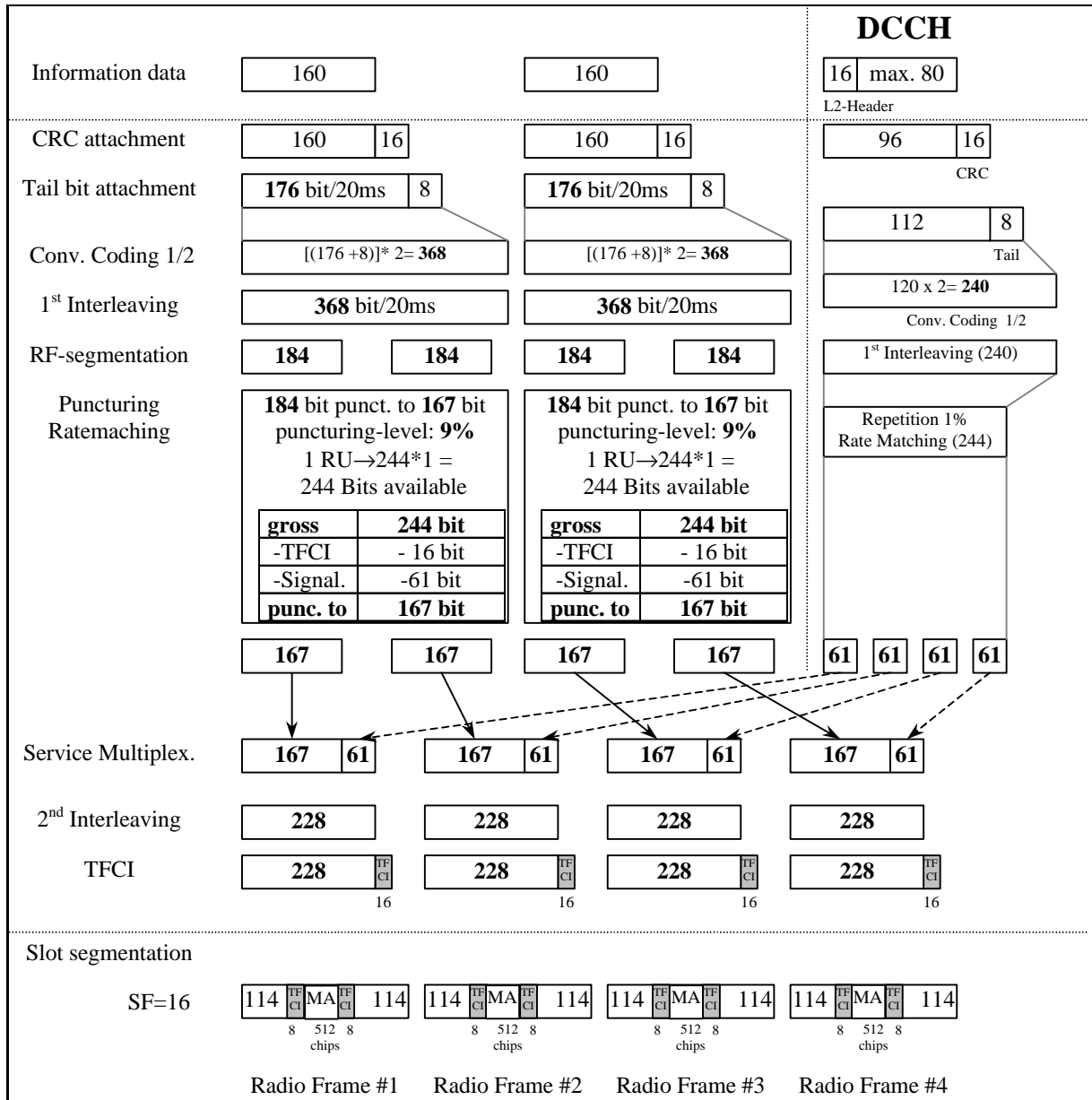

Example for 12.2 kbps data rate for Downlink

[mapped to 2 codes SF=16]

Parameter	
Information data rate	12.2 kbps
RU's allocated	2 RU
Midamble	512 chips
Interleaving	20 ms
Power control	0 Bit/user
TFCI	16 Bit/user
Inband signalling DCCH	2 kbps
Puncturing level at Code rate 1/3 : DCH / DCCH	5% / 0 %

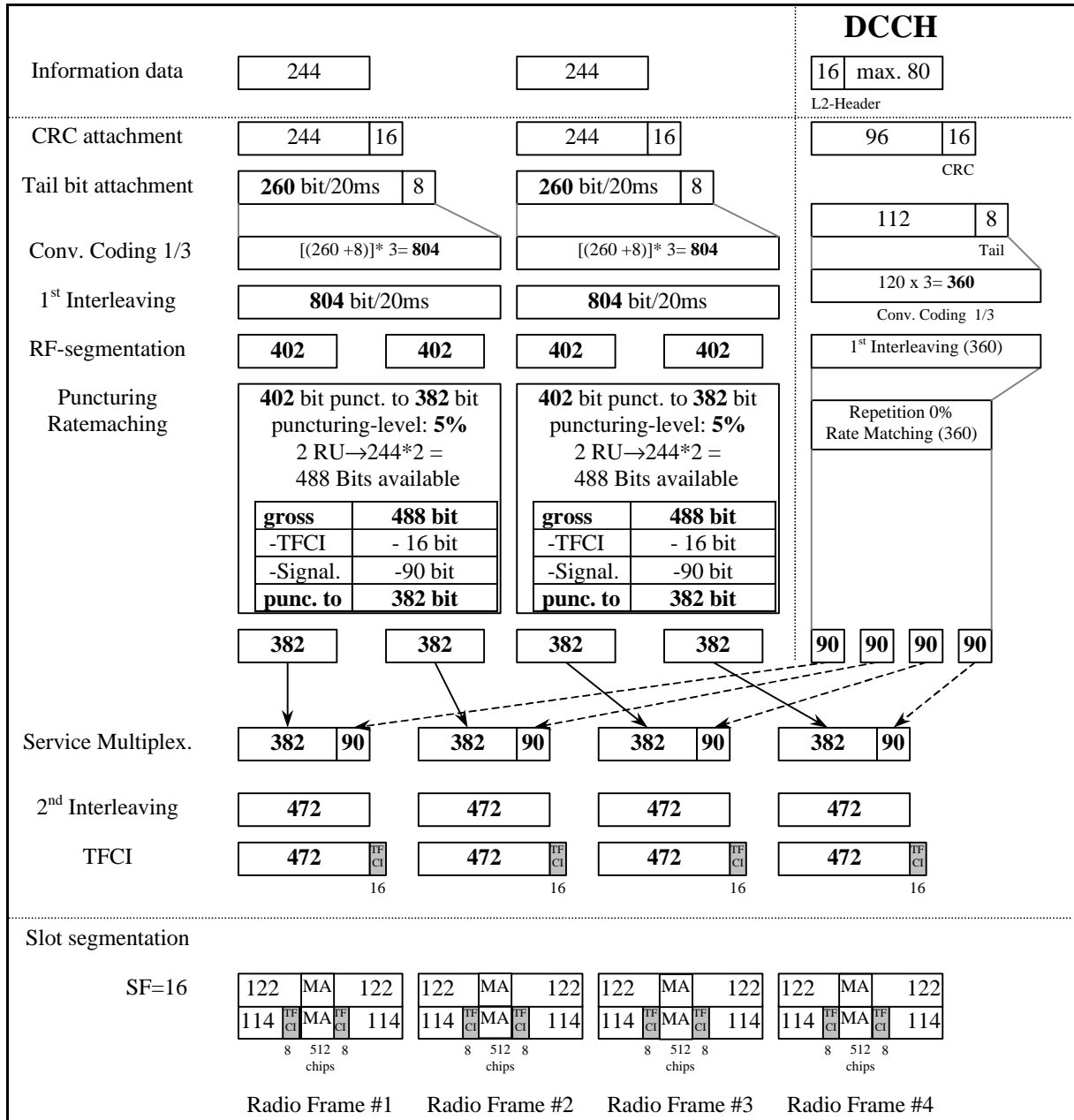

Example for 64 kbps data rate for Downlink

[mapped to 5 codes SF=16]

Parameter	
Information data rate	64 kbps
RU's allocated	5 codes SF16 = 5RU
Midamble	512 chips
Interleaving	20 ms
Power control	0 Bit/user
TFCI	16 Bit/user
Inband signalling DCCH	2 kbps
Puncturing level at Code rate 1/2 : DCH / DCCH	11.7% / 10%

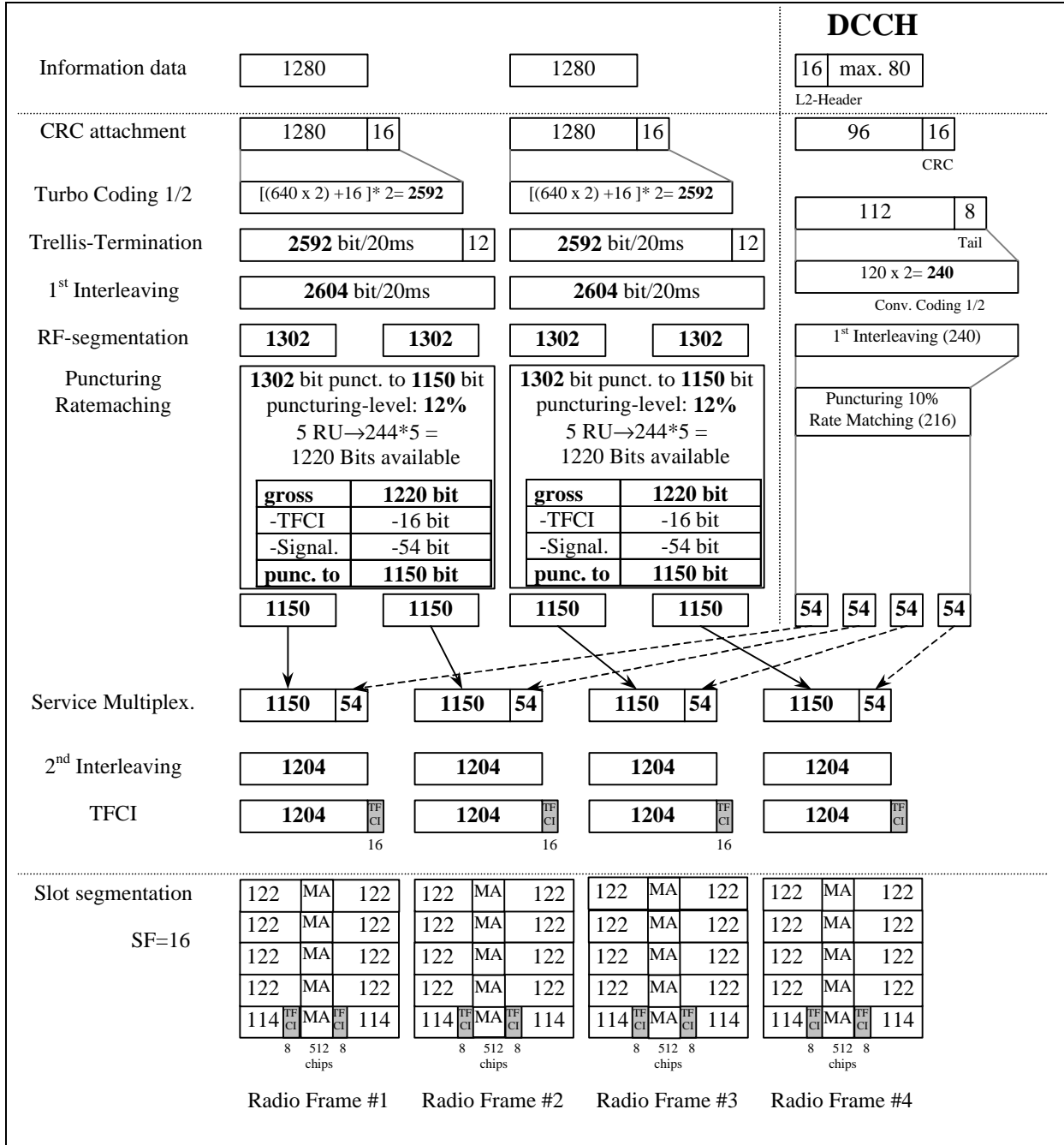

Example for 144 kbps data rate for Downlink

[mapped to 9 codes SF=16]

Parameter	
Information data rate	144 kbps
RU's allocated	9 codes SF16 = 9RU
Midamble	256 chips
Interleaving	20 ms
Power control	0 Bit/user
TFCI	16 Bit/user
Inband signalling DCCH	2 kbps
Puncturing level at Code rate 1/2: DCH / DCCH	16.7% / 16.6%

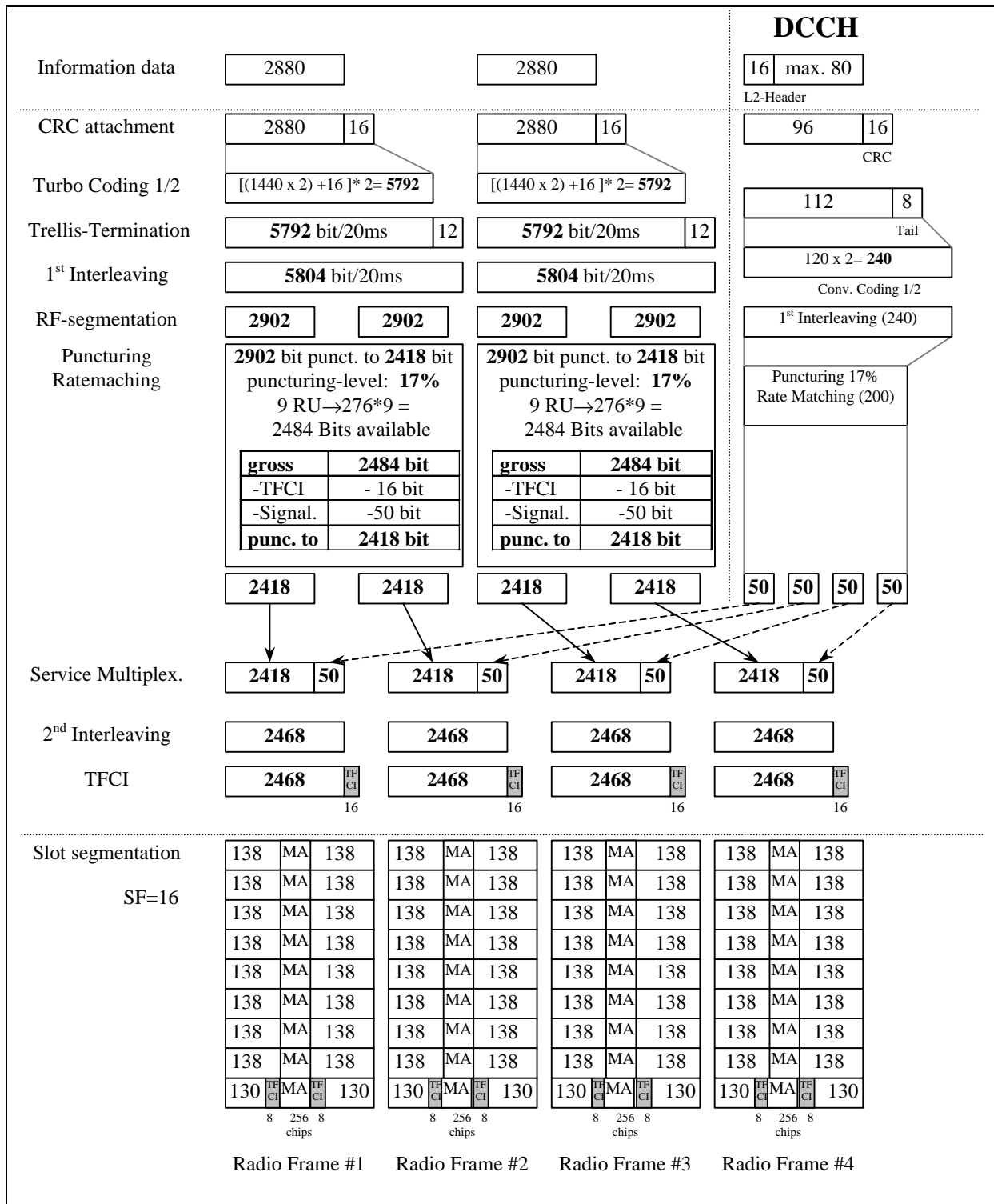

Example for 384 kbps data rate for Downlink

[mapped to 3 TS with 8 codes SF=16 in each]

Parameter	
Information data rate	384 kbps
RU's allocated	8*3TS = 24RU
Midamble	256 chips
Interleaving	20 ms
Power control	0 Bit/user
TFCI	16 Bit/user
Inband signalling DCCH	2 kbps
Puncturing level at Code rate 1/2 : DCH / DCCH	15.1% / 15.3%

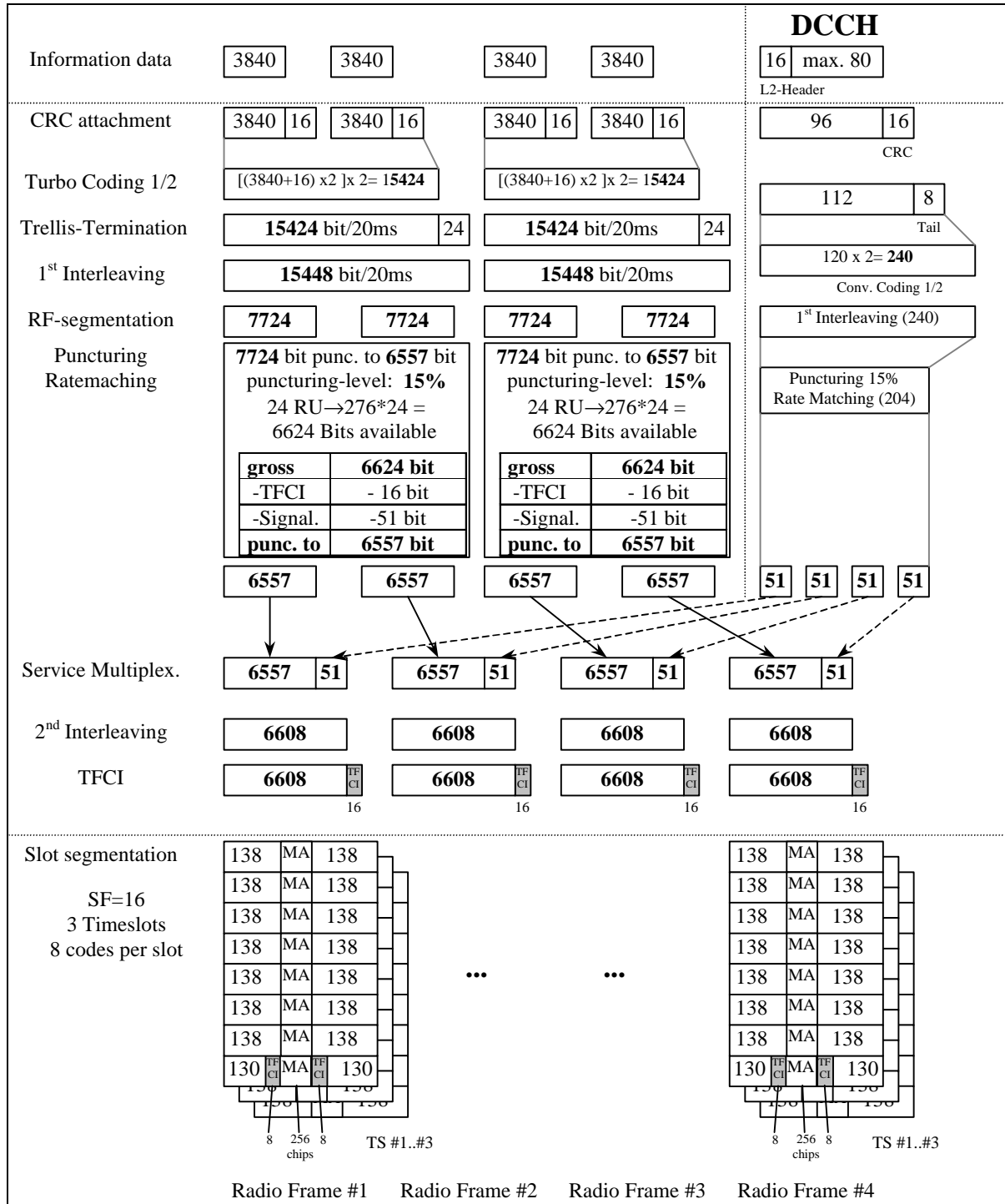

Example for 2048 kbps data rate for Downlink

[mapped to 12 TS with 1 code SF=1 in each]

Parameter	
Information data rate	2048 kbps
RU's allocated	16*12TS = 192RU
Midamble	256 chips
Interleaving	20 ms
Power control	0 Bit/user
TFCI	16 Bit/user
Inband signalling DCCH	2 kbps
Puncturing level at Code rate 1/3 : DCH / DCCH	14.3% / 0%

