

**Overview of 3GPP Release 4**

**Summary of all Release 4 Features**

**v. TSG #26**

## Credits

This document has been produced by the ETSI MCC department, headed by Adrian Scrase and then by John Meredith, namely Adrian Zoicas, Alain Sultan, Andrijana Jurisic, Cesar Gutierrez, Claude Arzelier, David Boswarthick, Friedhelm Rodermund, Jürgen Caldenhoven, Kimmo Kymalainen, Michael Clayton, Paolo Usai, Per Johan Jorgensen and Maurice Pope. The work was coordinated by Alain Sultan, who wishes to acknowledge all contributors for the quality of their inputs.

## Table of Content

<b>1</b>	<b>INTRODUCTION.....</b>	<b>5</b>
1.1	SCOPE.....	5
1.2	REFERENCES.....	5
1.2.1	<i>Specifications</i> .....	5
1.3	TDOCS.....	5
1.3.1	<i>Work Plan, Work Items and Study Items</i> .....	6
1.3.2	<i>Change Request database</i> .....	6
<b>2</b>	<b>NEW FEATURES APPLICABLE TO UMTS AND GSM.....</b>	<b>6</b>
2.1	BEARER INDEPENDENT CS ARCHITECTURE (ALSO CALLED “BEARER INDEPENDENT CORE NETWORK”).....	6
2.1.1	<i>Introduction</i> .....	7
2.1.2	<i>Architecture</i> .....	7
2.1.2.1	(G)MSC Server.....	8
2.1.2.2	Circuit Switched - Media Gateway (CS-MGW).....	8
2.1.3	<i>Interfaces and protocols</i> .....	8
2.1.3.1	Mc Reference Point: (G)MSC server to CS-MGW.....	8
2.1.3.2	Nc Reference Point: MSC Server to (G)MSC Server.....	8
2.1.3.3	Nb Reference Point: CS-MGW to CS-MGW.....	9
2.2	FEATURES RELATED TO SPEECH ENCODING AND DECODING.....	9
2.2.1	<i>General speech coding concepts</i> .....	9
2.2.2	<i>Relationship between TFO, TrFO and OoBTC</i> .....	10
2.2.3	<i>Tandem Free Operation (TFO) or In-band TFO</i> .....	10
2.2.4	<i>Transcoder-Free Operation/ Out-of-Band Transcoder Control</i> .....	11
2.3	TRANSPARENT END-TO-END PS MOBILE STREAMING APPLICATION.....	12
<b>3</b>	<b>UMTS-ONLY NEW FEATURES.....</b>	<b>14</b>
3.1	LOW CHIP RATE TDD OPTION.....	14
3.1.1	<i>Introduction</i> .....	15
3.1.2	<i>Physical layer</i> .....	16
3.1.3	<i>Layer 2 and Layer 3</i> .....	17
3.1.4	<i>UE radio access Capability</i> .....	18
3.1.5	<i>Iub/Iur protocol aspects</i> .....	18
3.1.6	<i>Measurement and testing of radio propagation</i> .....	18
3.1.7	<i>Interworking with GERAN</i> .....	18
3.2	UTRA FDD REPEATER SPECIFICATION.....	19
<b>4</b>	<b>GSM-ONLY NEW FEATURES.....</b>	<b>20</b>
4.1	700 MHz SPECTRUM SUPPORT.....	20
<b>5</b>	<b>IMPROVEMENTS OF UMTS AND GSM PRE-RELEASE 4 FEATURES.....</b>	<b>21</b>
5.1	MULTIMEDIA MESSAGING SERVICE.....	21
5.2	MEXE ENHANCEMENTS REL-4.....	23
5.3	ADVANCED SPEECH CALL ITEMS ENHANCEMENTS_REL-4.....	24
5.4	REL-4 EVOLUTIONS OF THE TRANSPORT IN THE CN.....	25
5.5	REL-4 EMERGENCY CALL ENHANCEMENTS.....	26
5.6	REL-4 TERMINAL INTERFACES.....	26
5.6.1	<i>AT-commands enhancements</i> .....	26
5.6.2	<i>Wide Area Data Synchronisation</i> .....	27
5.6.3	<i>Terminal Local Model</i> .....	28
5.7	REL-4 LOCATION SERVICES ENHANCEMENTS.....	28
5.7.1	<i>General aspects</i> .....	28

5.7.2	<i>Iub/Iur interfaces for UE positioning methods supported on the radio interface Release 99 (applicable only to UMTS)</i> .....	29
5.8	REL-4 UICC/(U)SIM ENHANCEMENTS AND INTERWORKING.....	29
5.8.1	<i>Addition of CPHS features</i> .....	30
5.8.2	<i>Other aspects</i> .....	30
5.9	REL-4 (U)SIM TOOLKIT ENHANCEMENTS.....	30
5.10	REL-4 OPEN SERVICE ACCESS (OSA) IMPROVEMENTS.....	31
<b>6</b>	<b>IMPROVEMENTS OF UMTS-ONLY PRE-RELEASE 4 FEATURES</b> .....	<b>32</b>
6.1	QoS ARCHITECTURE FOR PS DOMAIN.....	32
6.1.1	<i>RAB Quality of Service (re)Negotiation</i> .....	33
6.1.1.1	<i>RAB Quality of Service Negotiation over Iu</i> .....	33
6.1.1.2	<i>RAB Quality of Service Renegotiation over Iu</i> .....	33
6.1.1.3	<i>RAB Quality of Service Negotiation over Iu during Relocation</i> .....	33
6.1.2	<i>PS-Domain handover for real-time services</i> .....	33
6.2	REL-4 EVOLUTIONS OF THE TRANSPORT IN THE UTRAN.....	34
6.2.1	<i>QoS optimization for AAL type 2 connections over Iub and Iur interfaces</i> .....	34
6.2.2	<i>Transport bearer modification procedure on Iub, Iur, and Iu</i> .....	35
6.3	REL-4 IMPROVEMENTS OF RADIO INTERFACE.....	35
6.3.1	<i>DSCH power control improvement in soft handover</i> .....	35
6.4	REL-4 RAN IMPROVEMENTS.....	36
6.4.1	<i>Node B synchronisation for TDD</i> .....	36
6.4.2	<i>Radio Access Bearer Support Enhancements for Rel-4</i> .....	37
<b>7</b>	<b>IMPROVEMENTS OF GSM-ONLY PRE-RELEASE 4 FEATURES</b> .....	<b>38</b>
7.1	GB OVER IP (GERAN IMPROVEMENTS 1).....	38
7.2	NETWORK ASSISTED CELL CHANGE - NACC (GERAN IMPROVEMENTS 2).....	39
7.3	DELAYED TBF (GERAN IMPROVEMENTS 4).....	40
<b>8</b>	<b>OTHER ASPECTS</b> .....	<b>41</b>
8.1	REL-4 CHARGING AND OAM&P.....	41
8.2	MISCELLANEOUS UE CONFORMANCE TESTING ACTIVITIES.....	42
8.3	SMALL TECHNICAL ENHANCEMENTS AND IMPROVEMENTS FOR REL4.....	43
8.4	FACSIMILE GROUP 3, NON TRANSPARENT.....	43
8.5	“HOLLOW” FEATURES.....	44
8.5.1	<i>Operator Determined Barring for Packet Oriented Services</i> .....	44
8.5.2	<i>Rel-4 Security enhancements</i> .....	44
8.5.3	<i>Global Text Telephony</i> .....	44

# 1 Introduction

## 1.1 Scope

This document contains a high-level description of the 3GPP Release 4 Features.

A Feature is defined as new or substantially enhanced functionality which represents added value to the existing system. A feature should normally embody an improved service to the customer and / or increased revenue generation potential to the supplier.

Features are as independent as possible from each other, and relationships between features (if any) are clarified here.

In some cases, a feature does not correspond to a single functionality but consists in a grouping of different independent items impacting the same parts of the system (e.g. "Release 4 RAN improvements"). These groupings are performed to artificially limit the total number of features for each Release. For these "basket" features, a summary of each item is provided.

For each feature (or independent item), references are given to guide the reader on how to deepen the subject: the Work Item Description (WID) as well as the list of impacted specifications are provided in the beginning of the section describing the feature. Only the list of impacted specifications is provided here. The exact impact on a given specification due to a given feature is described in the Change Request (CR) list, which can be found at the end of the specification, or in the CR database, which provides the full list of CRs for all 3GPP specifications.

The second part of this introduction contains global references, and provides links towards the 3GPP Specifications, the temporary documents (tdocs), the Work Plan, the Work Item Descriptions (WIDs) and the CR database.

The main body of this document is structured according to the 3GPP Release 4 Features: each chapter corresponds to one Release 4 Feature.

## 1.2 References

### 1.2.1 Specifications

Global information on the Specifications (also called "specs") can be found at:

<http://www.3gpp.org/specs/specs.htm>

The latest versions of all 3GPP specifications, containing the most recent corrections and additions, are available at:

<http://www.3gpp.org/ftp/Specs/latest/>

For specific purposes, older versions might be needed. These versions are available at:

<http://www.3gpp.org/ftp/Specs/Archive/>

where the specifications are sorted by series and then by folders containing all the available versions of a given spec (one folder per spec), for all Releases.

## 1.3 Tdocs

The Temporary Documents (tdocs) are mainly the original papers written by the 3GPP Members, and are the inputs for elaborating the specs. They are available (sorted by 3GPP technical groups (Technical Specification Groups (TSGs) and Working Groups (WGs)) at:

<http://www.3gpp.org/ftp/>

starting with 'tsg....'.

### 1.3.1 Work Plan, Work Items and Study Items

Work Item Description (“WID”) (also called WI Description) and Study Item (also called "Feasibility Studies") are forms which initial version provides the target to be reached before starting the technical work. Potential subsequent versions narrow the target and foreseen completion date according the actual progress. They are stored in:

[http://www.3gpp.org/ftp/Information/WI\\_sheets/](http://www.3gpp.org/ftp/Information/WI_sheets/)

The 3GPP Work Plan is a living document, updated roughly each month, which contains the full list of Work Items and Study Items, as well as summary information for each WI, as: the WG in charge of it, its starting date and (foreseen or actual) completion date, the actual progress, etc. The Work Plan is available at:

[http://www.3gpp.org/ftp/Information/WORK\\_PLAN/](http://www.3gpp.org/ftp/Information/WORK_PLAN/)

### 1.3.2 Change Request database

A specification is originally drafted and maintained by a rapporteur, who compiles the contents from discussions in the WGs and TSGs. When it is considered to be 80% complete, it is brought under a so-called "change control" process. After this, changes to the specification can only be made using Change Requests that are usually agreed by consensus in the Working Group responsible for the specification, and then formally approved by the relevant Technical Specification Group<sup>1</sup>.

The Change Request database contains all available information on Change Requests, including a Work Item code, a Change Request number that is unique within the specification (different versions are possible, but only one can ever be approved), the status of each Change Request and references to relevant temporary document numbers and meetings. This database is available in:

[http://www.3gpp.org/ftp/Information/Databases/Change\\_Request/](http://www.3gpp.org/ftp/Information/Databases/Change_Request/)

Further information on CR is available at:

<http://www.3gpp.org/specs/CR.htm>

## 2 New Features applicable to UMTS and GSM

### 2.1 Bearer Independent CS architecture (also called “Bearer Independent Core Network”)

**Acronym:** CSSPLIT / BICC  
**UID:** 1322  
**Main responsibility:** CN4

**References for WI " Enable bearer independent CS architecture "**

<b>Document</b>	<b>Title/Contents</b>
NP-000538	Bearer Independent Circuit-Switched Core Network
<b>Impacted Specifications</b>	
TS 29.007	General requirements on Interworking between the PLMN and the ISDN or PSTN
TS 23.002	Network Architecture

---

<sup>1</sup> For a complete description on the handling of Specs and CRs at 3GPP, see the presentation in: <http://www.3gpp.org/ftp/Information/presentations/>

New Dedicated Specifications	
TS 23.205	Bearer-independent circuit-switched core network – Stage 2 Application of Q.1900 Series to Bearer Independent CS Core Network Architecture – Stage 3 Media Gateway Controller (MGC) – Media Gateway (MGW) Interface; Stage 3 Core Network Nb Data Transport and Signalling Transport  And the re-use of the ITU-T Q.19xx series of recommendations, in particular the Q.1902.x, as defined in TS 29.205
TS 29.205	
TS 29.232	
TS 29.414	

## 2.1.1 Introduction

The objective of this feature is to dissociate the transport and the control in the Circuit Switched (CS) domain. The aim is to offer a better transport resource efficiency and a convergence with the Packet Switched (PS) domain transport. Also, this enables to use one single set of layer 3 protocols (e.g. DTAP in TS 24.008 or MAP in TS 29.002) on top of different transport resources, as ATM, IP, STM, or even new ones.

The users shall not notice whether they are connected to a “bearer independent CS network” or to a classical CS domain. This implies that both types of network offer the same bearer and teleservices, and have same external behaviour for the handling of the call control, related supplementary services, application services and mobility support. Also, none of the protocols used on the radio interface is modified by this feature. This means for example there is no need for the terminals to support IP even if IP is the transport protocol used in the network.

## 2.1.2 Architecture

The basic principle is that the MSC is split into an MSC server and a (Circuit-Switched) Media Gateway (CS-MGW), the external interfaces remaining the same as much as possible as for a monolithic MSC. The MSC server provides the call control and mobility management functions, and the CS-MGW provides the stream manipulating functions, i.e. bearer control and transmission resource functions. The same applies to the GMSC, split into a GMSC server and a CS-MGW.

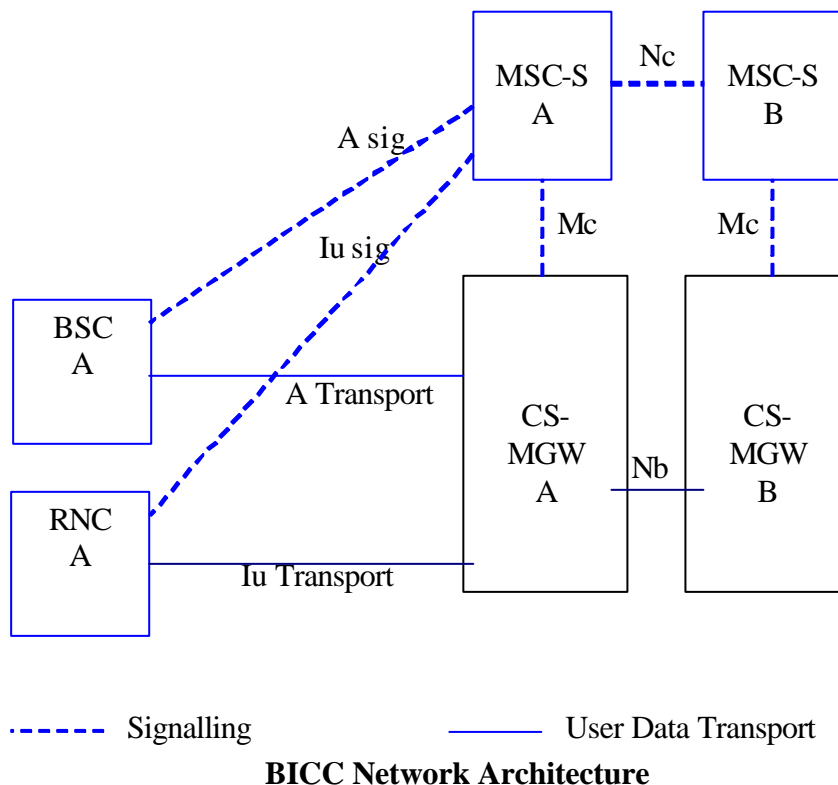

### 2.1.2.1 (G)MSC Server

The MSC Server comprises all the call control and mobility control parts of an MSC. As such, it is responsible for the control of mobile originated and mobile terminated CS domain calls. It terminates the user to network signalling (see in particular TS 24.008) and translates it into the relevant network to network signalling (see in particular TS 29.002). It also contains the VLR.

The MSC Server controls the parts of the call state that pertain to connection control for media channels in a CS-MGW.

A GMSC Server is to a GMSC as an MSC Server is to an MSC.

### 2.1.2.2 Circuit Switched - Media Gateway (CS-MGW<sup>2</sup>)

The CS-MGW interfaces the transport part of the UTRAN/BSC with the one of the core network, over Iu or the A interface. It interacts with the (G)MSC server for resource control.

A CS-MGW may also terminate bearer channels from a circuit switched network and media streams from a packet network (e.g., RTP streams in an IP network). As the entity interfacing the access and the core network, the CS-MGW operates the requested media conversion (it contains e.g. the TRAU), the bearer control and the payload processing (e.g. codec, echo canceller, conference bridge). It supports the different Iu options for CS services (AAL2/ATM based as well as RTP/UDP/IP based).

The CS-MGW bearer control and payload processing capabilities also need to support mobile specific functions such as SRNS relocation/handover and anchoring. Current H.248 standard mechanisms are applied to enable this. Further tailoring (i.e packages) of the H.248 may be required to support additional codecs and framing protocols, etc.

Note that no confusion should be made between the CS-MGW defined here and the IMS Media Gateway, the IM-MGW, defined in Release 5.

## 2.1.3 Interfaces and protocols

### 2.1.3.1 Mc Reference Point: (G)MSC server to CS-MGW

The Mc reference point describes the interfaces between the MSC Server and CS-MGW, and between the GMSC Server and CS-MGW. It supports a separation of call control entities from bearer control entities, and a separation of bearer control entities from transport entities.

It uses the H.248/IETF Megaco protocol, jointly developed by ITU-T and IETF, with the parameters and options specified in TS.29232 ("Media Gateway Controller (MGC) – Media Gateway (MGW) Interface; Stage 3)

It has the following properties:

- flexible connection handling which allows support of different call models and different media processing purposes not restricted to H.323 usage.
- open architecture where extensions/packages definition work on the interface may be carried out.
- dynamic sharing of MGW physical node resources. A physical MGW can be partitioned into logically separate virtual MGWs/domains consisting of a set of statically allocated terminations.
- dynamic sharing of transmission resources between the domains as the MGW controls bearers and manage resources according to the H.248 protocols.

Mobile specific functions such as SRNS relocation/handover and anchoring are also supported.

### 2.1.3.2 Nc Reference Point: MSC Server to (G)MSC Server

Over the Nc reference point, the Network-Network based call control is performed. Examples of this are ISUP or an evolution of ISUP for bearer independent call control (BICC). The protocol used on the Nc interface is specified in TS 29.205: "Application of Q.1900 Series to Bearer Independent circuit-switched core network architecture; Stage 3". In fact, the Nc interface uses ITU's BICC as specified in ITU Rec. Q.1902.x series of recommendations. It supports IP and ATM transports in a bearer-independent manner for the ISDN service set, allowing the physical separation of the call control entities from the bearer control entities, hence the name "Bearer-Independent Call Control".

The interworking between BICC and ISUP shall follow the ITU recommendation Q.1912.1 ("ISUP-BICC Interworking") and Q.19.12.2 ("Interworking between selected signalling systems and BICC").

---

<sup>2</sup> CS-MGW might also be referred as MGW when there is no ambiguity with IM-MGW.



### 2.1.3.3 Nb Reference Point: CS-MGW to CS-MGW

Over the Nb reference point, the bearer control and transport are performed. Different options are possible for user data transport and bearer control, as defined in TS.29.414 ("Core Network Nb Data Transport and Signalling Transport"). It can be IP bearer control protocol, BICC tunnelling protocol, "AAL type 2 signalling protocol (Q.2630.1-2).

In the case of ATM or IP transport, the passage of compressed speech at variable bit rates is possible through the CS core network.

## 2.2 Features related to Speech encoding and decoding

### 2.2.1 General speech coding concepts

In a normal MS<sup>3</sup> to MS call configuration, the Speech Signal is first encoded in the originating MS, sent over the Air Interface and on Ater, converted in the local transcoder (the TRAU) to A-law or  $\mu$ -law ITU-T Rec. G.711, carried over the fixed network, transcoded again in the distant transcoder, sent over the distant Air Interface and finally decoded in the terminating MS. When the Iu interface is used, the transcoder is in the MSC.

The figure below, extracted from TR 23.977, shows the different types of transcoding taking place for end-to-end calls, in case BICC is used (see first chapter). The end-user is either a PSTN-user (upper part of the figure), or she/he is a GSM/GERAN user (middle part) or she/he is a UMTS-user (lower part). The figure is limited to the infrastructure side of the end-to-end call, i.e. the radio interface and the MSs are not shown.

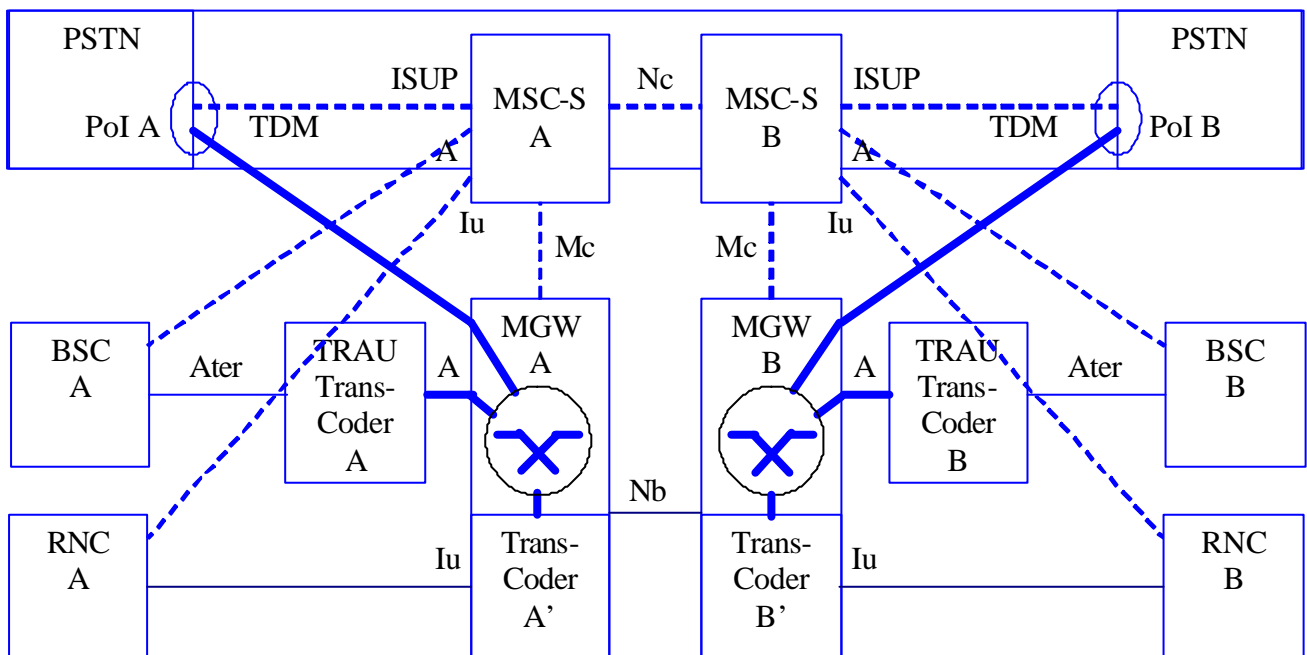

- - - - - Call Control Signalling    
 ——— Ater Interface    
 ——— A and TDM Interface: 64kb/s  
——— Iu and Nb Interface

PoI: Point of Interconnect

#### Bearer Independent Core Network with A- and Iu-Interfaces

In this configuration, the two speech codecs (coder/decoder pairs) at both ends are said to be in "Tandem Operation" as they introduce a double transcoding. The key inconvenience of a tandem configuration is the

<sup>3</sup> MS (Mobile Station) and UE (User Equipment) both refer to the set of devices the user carries with him to access GSM/UMTS services, namely: the "phone" (or Mobile Termination, MT), the (U)ICC card containing the (U)SIM application, and potentially a PC, a PDA, etc (the Terminal Equipment, TE). In the standard, "MS" is reserved for GSM and "UE" for UMTS. This distinction was thought to be useless by the authors and so it is not followed in this document: MS and UE are used indistinctively.

degradation of the speech quality. This degradation is usually more noticeable when the speech codecs are operating at low rates and in noisy conditions.

To avoid this double transcoding, different mechanisms have been defined: the “Out-of-Band Transcoder Control” (OoBTC), the “Tandem Free Operation” (TFO, also called “in-band TFO” as it uses in-band signalling<sup>4</sup>), and the “Transcoder free operation” (TrFO).

## 2.2.2 Relationship between TFO, TrFO and OoBTC

Tandem Free Operation (TFO) removes the double speech encoding/decoding done in the TRAU in MS-to-MS calls by ‘tunnelling’ the ‘compressed’ speech through the 64 kbit/s PCM (Pulse Code Modulation) links of the core network. “Compressed” speech refers to speech coding and configuration used on the radio interface, excluding radio channel related information.

No transmission resources are saved in the core network as PCM links are still used, but it mainly improves the perceived speech quality in mobile-to-mobile calls.

With Transcoder Free Operation (TrFO), there is no constraint to use PCM link on the Nb interface, so, in addition of the advantages proposed by TFO, there is also a saving of transmission resources. TrFO can also be used in mobile-to-fix calls: the mobile to fix transcoding is done at the edge of the mobile network, hence resource are saved in the mobile network.

Finally, Out of Band Transcoder Control (OoBTC) is the mechanism to establish the Transcoder Free Operation. It is the capability of a system to negotiate the types of codecs and codec modes on a call per call basis through out-of-band signalling. OoBTC is used before call set-up. If the OoBTC fails to establish the TrFO and transcoders are required, then (in-band) TFO may be used after call set-up. TFO shall be the fallback mechanism when transcoders cannot be avoided, either at set-up or during the communication phase.

When looking on the figure above, OoBTC/TrFO on the Nc/Nb interface or TFO on the Nb interface provide the means to transport speech in compressed form on the Nb interface. The MSC-Ss know, negotiate and select the speech Codec Types and Configurations on the Iu and on the Nb Interface.

If the MSC-Ss determine G.711 as the codec used between the MGWs, then the MGWs may afterwards establish TFO at the Nb interface. In this case, the transcoders in the MGWs know and negotiate the speech codec configuration on the Nb interface, and they inform the MSC-Server of this configuration indicating that TFO is possible. If the transcoder is in the BSCs, the BSCs know and select the speech codec type and configuration on the A-ter interface to enable TFO operation on the A interface.

## 2.2.3 Tandem Free Operation (TFO) or In-band TFO

*Full official name: Tandem Free aspects for 3G and between 2G and 3G system*

**Acronym:** TFO  
**UID:** 1631 (and BB 1632 on Tandem Free AMR)  
**Main responsibility:** S4

### References for WI " Tandem Free aspects for 3G and between 2G and 3G systems "

Document	Title/Contents
None	WID Sheet not produced (WI moved from R99 to Rel-4)
<b>Impacted Specifications</b>	
TS 22.053 TS 23.153 TS 28.062	Tandem Free Operation (TFO); Service Description; Stage 1 Out of Band Transcoder Control; Stage 2 Inband Tandem Free Operation (TFO) of speech codecs; Service description; Stage 3
<b>New Dedicated Specifications</b>	
	None

<sup>4</sup> The terminology “TFO”, as opposed to “in-band TFO”, is chosen in this document (except in references).

TFO, which removes the double speech encoding/decoding done in the TRAU in mobile-to-mobile calls by tunnelling the radio-encoded speech on the PCM links, is intended to be used for mobile-to-mobile call configurations (MS/UE to MS/UE, see previous footnote on MS/UE terminology).

In addition of improving the perceived speech quality, TFO saves DSP (Digital Signal Processor) resources, and allows new speech services like wideband speech. Generally, no transmission resources are saved in the core network as PCM links are still used. Possible savings could be done in case the inter-PLMN transmission links carry compressed speech compatible with a 16 kbit/s or 8 kbit/s sub-multiplexing scheme, including packet switched transmission. Also possible reduction in the end-to-end transmission delay is sometimes mentioned as an advantage of TFO.

The TFO in-band signalling is controlled by the TRAU after call set-up, and is described in TS 28.062. The procedure is that in case two transcoders are in tandem (a pair of transcoders with PCM coding between them) and are able to communicate to each other (i.e. both support TFO), then the TFO protocol allows the transcoders to compare coding schemes. If compatible codec types exist, the transcoders are able to overwrite the PCM coding with the pure compressed speech (effectively bypassing the transcoding functions).

Using in-band signalling implies that the link between the TRAU is transparent in the sense that the content of what is emitted by a TRAU is not modified. The so-called In Path Equipments must therefore be disabled or configured in such a way that the information (signalling and coded speech) required for Tandem Free is not altered.

Note that if the TFO protocol is not supported by both transcoders or the coding schemes are not compatible then normal "Tandem" operation occurs and PCM encoded speech is passed between them.

In case the TFO connection can not be maintained (e.g. because of activation of supplementary services causing insertion of CCD, DTMF, tones, etc), the protocol ideally provides a fast and seamless fallback to Tandem Operation.

TFO is defined for the different Speech Codec Types used in GSM and GSM-evolved 3G systems. This includes the GSM\_FR, GSM\_HR, GSM\_EFR and FR\_AMR, HR\_AMR, UMTS\_AMR, UMTS\_AMR\_2 codec types. However, the procedures used to establish TFO are considered system independent and could be extended to call configurations involving other systems like ISDN phones, speech servers, IP Multimedia or other wireless systems.

For non-AMR Speech Codec Types (i.e. GSM\_FR, GSM\_EFR and GSM\_HR), TFO is fully compatible with the installed equipment base. The feature is fully supported by the Transcoder Units. The additional processing complexity is small compared to the encoding/decoding functions. Other network elements are not affected and possibly not aware of the establishment of TFO.

For the support of AMR TFO in GSM, the BTS and possibly the BSC may be involved in addition to the TRAU.

The resolution of a possible codec mismatch is defined as an optional feature. A codec mismatch occurs when incompatible speech codecs are used at both ends of the call configuration at call set-up. The resolution consists in finding an optimal speech codec on which TFO may be established. For that purpose, other elements in the Radio Access Network (BSS in GSM or RNC in 3G) might be involved. The communication channel between the Transcoder Units and the other network elements used to transfer network parameters to solve a codec mismatch is considered a proprietary interface, and is not further defined in TS 28.062. For GSM AMR, provision exists in the TRAU Frames to carry the network parameters across the Abis/Ater interface (see TS 48.058, 48.060 and 48.061).

Note that RAN and CN have to verify UMTS\_AMR\_2 support in Release 4.

The main difference between OoBTC and TFO is that OoBTC is performed before call setup and TFO immediately after call setup.

## 2.2.4 Transcoder-Free Operation/ Out-of-Band Transcoder Control

<b>Acronym:</b>	OoBTC
<b>UID:</b>	1541
<b>Main responsibility:</b>	N4

### References for WI " Transcoder-Free Operation "

Document	Title/Contents
NP-000529	WID for Out of band Transcoder Control
<b>Impacted Specifications</b>	
TS 24.008 <sup>5</sup>	Mobile radio interface Layer 3 specification; Core network protocols; Stage 3
TS 26.108	
<b>New Dedicated Specifications</b>	
TS 23.153	Out of band Transcoder Control; Stage 2

Initially, this WI was started for Release 99. However, a significant amount of open issues were not closed on time so the WI was postponed to Release 4 and all remaining issues identified in Release 99 were resolved.

Out-of-Band Transcoder is the mechanism to establish the Transcoder Free Operation. Transcoder Free Operation (TrFO) is defined as the configuration of a speech or multimedia call for which no transcoder device is physically present in the communication path between the source codecs and hence no control or conversion or other functions can be associated with it.

In case of mobile to fixed network calls, the term "Transcoder free operation" is applicable for the TrFLs carrying compressed speech. TrFLs (Transcoding free link) refers to a bearer link where compressed voice is being carried between bearer endpoints. The TrFO usually ends at the Gateway to the PSTN where the speech is transcoded e.g. to G.711.

Although the main reason for avoiding transcoding in mobile-to-mobile calls has been speech quality, the transmission of compressed information in the CN and CN-CN interface of the cellular network also offers the possibility of bandwidth savings. Therefore Out-of-Band Transcoder Control is not limited to mobile-to-mobile calls but can be applied for calls to or from an external network as well.

In order to allocate transcoders for a call inside the network, and to select the appropriate codec type inside the UEs, signalling procedures are defined to convey the codec type selected for a call to all the affected nodes (UEs and potential transcoding points inside the network). Also, codec negotiation capabilities have been defined to enable the selection of a codec type supported in all the affected nodes, i.e. to resolve codec mismatch situations. This codec negotiation maximises the chances of operating in compressed mode end-to-end for mobile-to-mobile calls.

To allow transport of information in a compressed way in transmission networks, these networks make use of the transport -independent call control protocol as specified in TS 23.205 that provides means for signalling codec information, negotiation and selection of codecs end-to-end.

## 2.3 Transparent End-to-End PS mobile streaming application

**Acronym:** PSTREAM  
**UID:** 1539  
**Main responsibility:** S4

---

<sup>5</sup> Out-of-Band Transcoder Control requires the capability to indicate preferable transcoder types from the MT to the network and vice versa employing Call Control messages as a means of transport. The parameter for BICC protocol need to be adjusted. (Ex. OID)

**References for WI " Transparent End-to-End PS mobile streaming application "**

Document	Title/Contents
SP-000345	WI Description
<b>Impacted Specifications</b>	
TS 26.233	Transparent end-to-end packet switched streaming service (PSS); General description
TS 26.234	Transparent end-to-end packet switched streaming service (PSS); Protocols and codecs
<b>New Dedicated Specifications</b>	
	None

Streaming refers to the ability of an application to play synchronised media streams, like audio and video, in a continuous way while those streams are being transmitted to the client over a data network.

The applications which can be built on top of streaming services can be classified into “on-demand” and “live” information delivery. Examples of the first category are music and news-on-demand applications. Live delivery of radio and television programs are examples of the second category.

PSS-only mobiles are envisaged as their complexity would be lower than for conversational services: there is no need for media input devices, media encoders and some protocols can be avoided.

Streaming over fixed-IP networks is already a major application. While the Internet Engineering Task Force (IETF) and the World Wide Web Consortium (W3C) have developed a set of protocols used in fixed-IP streaming services, for 3G systems, the 3G packet-switched streaming service (PSS) fills the gap between 3G MMS, e.g. downloading, and conversational services.

This feature enables a multitude of streaming applications to be deployed by independent content providers. The advantage from a user’s perspective is to have access to a much broader set of content as in a closed configuration.

The 3GPP streaming is to be used both on top of GPRS/EDGE and UMTS. As an issue specific to mobile streaming, applicable to both types of access networks (GPRS and UMTS), the coupling between the browser and the streaming client have been addressed. Indeed, some mobile terminals have limited possibility of software plug-ins. Also specific to mobile, a default set of streaming protocols and codecs has been specified.

By contrast to the fixed Internet access, connection time is much more costly and the quality can be much worse, in particular in Release 4, as no specific content protection has been developed in this Release.

The mobile streaming service standardized by this feature covers the different components: streaming protocols, media transport protocols and multimedia codecs. Note that the wideband codec ITU-T G.722.2 has been made allowable for this release 4 work item, while the "AMR-WB service" is a feature which is part of the 3GPP Release 5.

TS 26.233 defines the usage scenarios, overall high level end-to-end service concept, and lists terminal-related functional components. It also lists any identified service interworking requirements. PSS protocols for control signalling, scene description, media transport and media encapsulations are specified in TS 26.234. TS 26.234 also specifies the codecs for speech, audio, video, still images, bitmap graphics, and text. Vector graphics belongs to the extended PSS features and is not specified in 3GPP Release 4.

The mobile streaming application allows various charging models.

Transport security aspects were covered as well (see TS 33.102 "Security architecture").

Harmonization with existing and emerging 3GPP multimedia applications has been considered whenever possible.

## 3 UMTS-only new Features

### 3.1 Low Chip Rate TDD option

*This section was elaborated in co-operation between MCC and the following Datang Mobile experts: Liyan Yin, Ke Wang, Darun Wang, Na Wu , Guiliang Yang, Qingguo Feng, Yusong He. Many thanks to all of them.*

**Acronym:** LCRTDD  
**UID:** 1222  
**Main responsibility:** RAN WG1

Structure of the feature:

UID	Task name	WG	Acronym
1223	Physical layer	R1	LCRTDD-Phys
1224	Layer 2 and layer 3 protocol aspects	R2	LCRTDD-L23
1225	"RF radio transmission/reception, system performance requirements and conformance testing"	R4	LCRTDD-RF
1227	UE radio access capability	R2	LCRTDD-UErac
1228	Iub/Iur protocol aspects	R3	LCRTDD-IubIur
2262	Low chiprate TDD interworking with GERAN	GERAN	

The Work Item Description Sheets can be found in the file RAN\_Work\_Items\_History in:  
[ftp://ftp.3gpp.org/tsg\\_ran/TSG\\_RAN/Work\\_Item\\_sheets/](ftp://ftp.3gpp.org/tsg_ran/TSG_RAN/Work_Item_sheets/)

#### References for WI "Low Chip Rate TDD option"

Impacted Specifications / Reports	
25.102	UE Radio Transmossion and Reception (TDD)
25.104	BTS Radio Transmission and Reception (FDD)
25.105	BTS Radio Transmission and Reception (TDD)
25.123	Requirements for support of Radio Resource Management (TDD)
25.142	Base station conformance testing(TDD)
25.113	Base station EMC
25.133	Requirements for support of Radio Resource Management (FDD)
25.201	Physical layer – General description
25.221	Physical channels and mapping of transport channels onto physical channels (TDD)
25.222	Multiplexing and channel coding (TDD)
25.223	Spreading and modulation (TDD)
25.224	TDD; physical layer procedures
25.225	Physical layer; measurements
25.302	Services Provided by the physical layer
25.303	UE functions and Inter-layer procedures in connected mode
25.304	UE procedures in idle mode and procedures for cell reselection in connected mode
25.305	User Equipment (UE) positioning in Universal Terrestrial Radio Access Network (UTRAN); Stage 2
25.306	UE Radio Access capabilities definition
25.321	Medium access control (MAC) protocol specification
25.331	Radio resource control (RRC) protocol specification
25.401	UTRAN Overall Description
25.402	Synchronisation in UTRAN Stage 2
25.423	UTRAN Iur Interface RNSAP Signalling
25.425	UTRAN Iur Interface User Plane Protocols for Common Transport Channel data streams
25.427	UTRAN Iub/Iur Interface User Plane Protocols for DCH data streams
25.430	UTRAN Iub Interface: General Aspects and Principles
25.433	UTRAN Iub Interface NBAP Signalling
25.435	UTRAN Iub Interface User Plane Protocols for Common Transport Channel data streams
25.922	Radio Resource Management Strategies
25.944	Channel coding and multiplexing examples
44.018	Radio Resource Control Protocol
44.060	Radio Link Control / Medium Access Control Protocol
45.002	Multiplexing and multiple access on the radio path
45.008	Radio subsystem link control
48.008	MSC-BSS interface Layer 3 specification
48.058	BSC-BTS interface Layer 3 specification
24.008	Mobile radio interface Layer 3 specification; Core network protocols; Stage 3
34.108	Common test environments for User Equipment (UE) conformance testing
34.122	Terminal conformance specification, Radio transmission and reception (TDD)
34.123-1	User Equipment (UE) conformance specification; Part 1: Protocol conformance specification

34.123-2	User Equipment (UE) conformance specification; Part 2: Implementation conformance statement (ICS) specification
34.124	Electromagnetic compatibility (EMC) requirements for Mobile terminals and ancillary equipment

New Dedicated Technical Reports	
25.834	UTRA TDD low chip rate option; Radio protocol aspects
25.843	1.28 Mcps TDD UE Radio Access Capabilities
25.928	Low Chip Rate TDD Physical Layer
25.937	Low chip rate TDD Iub/Iur protocol aspects
25.945	RF requirements for 1.28 Mcps UTRA TDD option

### 3.1.1 Introduction

3GPP Release 99 UTRA (Universal Terrestrial Radio Access) included two basic modes of operation: Frequency Division Duplex (FDD) and Time Division Duplex (TDD). TDD can be introduced without needs for paired spectrum and is well-suited to asymmetric traffic.

In addition to Release 99 TDD, using a chip rate of 3.84 Mcps, Release 4 introduces an option that uses a chip rate of 1.28 Mcps. This mode is known as “1.28 Mcps TDD” through 3GPP specifications, and usually referred to as "Low Chip Rate TDD" (LCR TDD). In line with this formulation, R99 TDD is often called High Chip Rate TDD.

LCR TDD is also supported by ITU-R (where it is called “TD-SCDMA”) and Operators Harmonisation Group (OHG). LCR TDD operation mode is TDD mode. It takes advantage of various available Multiple Access techniques: TDMA, CDMA, FDMA, SDMA. As one of IMT-2000 compliant system, LCR TDD can support all the bearer services and diversified radio propagation environments corresponding to ITU requirement.

The chip rate of LCR TDD is 1.28Mcp. The benefit of LCR TDD is that it can be supported on unpaired frequency bands of 1.6MHz hence it is more flexible than FDD and 3.84Mcps TDD that request a minimum bandwidth of 5 MHz. It can be deployed not only for high spot or high density area to provide high speed data service or to provide enhanced coverage, but also to be used alone as macro cell to provide the service coverage. LCR TDD allows deployment together with existing GSM system, with FDD system, with 3.84Mcps TDD system and should support the handover between UTRA modes (e.g., LCR TDD to 3.84Mcps TDD, LCR TDD to FDD) and between systems (e.g., LCR TDD to GSM).

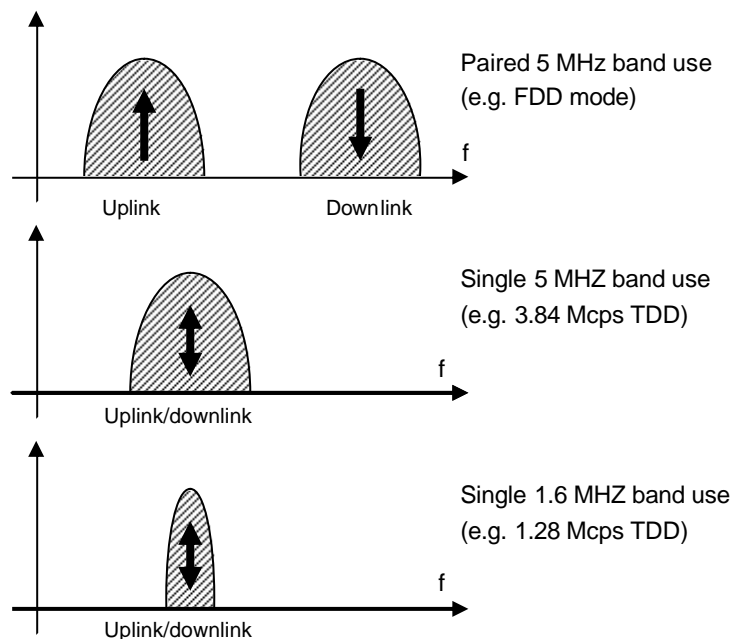

**Comparison between minimum bandwidth needed for FDD, HCR TDD and LCR TDD**

The goal of LCR TDD is to enable the full integration of TD-SCDMA and its specific properties into the Release 4 specifications of 3GPP. In other words, the integration work of all aspects of LCR TDD is designed to maximize the commonality with the 3.84Mcps TDD. As a result of this requirement, LCR TDD shares most of the aspects of the high layer and network elements as the other modes. But LCR TDD has its unique physical layer structure and key features. Correspondingly, some elements or parameters in high layer and interface for LCR TDD are added, modified or extended to adapt physical layer features. Also the differences on RF, system performance and conformance testing requirements of LCR TDD reflect the characteristic of an LCR TDD system.

The different system impacts of LCR TDD are described hereafter.

### 3.1.2 Physical layer

The main differences between LCR TDD and UTRA R99 TDD are on physical layer, e.g. the differences on the frame structure and synchronisation scheme.

#### Frame structure

In LCR TDD, a radio frame has a duration of 10 ms and is subdivided into 2 sub-frames of 5 ms each, each sub-frame is then subdivided into 7 traffic time slots (“Ts”) of 675  $\mu$ s duration each and 3 special time slots: DwPTS (downlink pilot timeslot), GP (guard period) and UpPTS (uplink pilot timeslot). This is different to 3.84 Mcps TDD, where there is no sub-frame. The LCR sub-frame of 5 ms allows for a faster update of power control and is well suited for smart antenna beamforming.

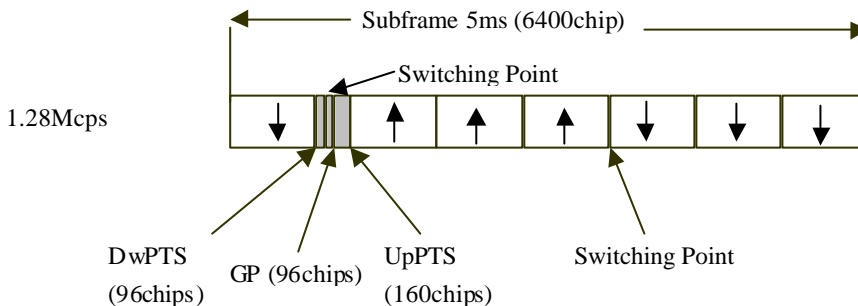

For high chip rate option, each 10 ms frame consists of 15 time slots, each allocated to either the uplink or the downlink. So it has both single and multiple-switching point configuration. While in the low chip rate option, the big Guard Period GP, the DwPTS and UpPTS physical channels are always between Ts0 and Ts1 whatever the level of asymmetry is, and there are always only 2 Switching Points per sub-frame.

The frame structure of LCR allows for a better control of the trade-off between quality and interference than with HCR. Indeed, given the switch of downlink to uplink, there is a risk of interference due to propagation delay. This risk of interference determines the size of cells. For the high chip rate option, there is no “DwPTS – guard – UpPTS” structure: the UL time slots are following the DL time slots immediately. This problem is avoided thanks to the guard period of LCR TDD.

#### Basic behaviour

In cell search procedure, unlike 3.84 Mcps TDD, the UE will search for the DwPCH at the first and then identify the scrambling code and basic midamble code.

Then, upon starting a transmission, the UE first accesses the cell through the UpPCH (uplink synchronisation burst, “power ramping”). The timing used for UpPCH is coarse and based on the DwPCH and P-CCPCH. The Node B will listen to the UpPCH burst, evaluate the timing and required power for the UE and send the information with the FPACH described below. The UE knows the correct timing and power level for the use of the PRACH, allowing for a more efficient use of resources (e.g. as the shorter initial sequence sent minimises interferences). This is similar to FDD mode “two step access”.

#### Physical Channels

Compared to R99 TDD, LCR TDD introduces new channels and removes others. The following channels are introduced:



- Two dedicated physical synchronisation channels: DwPCH and UpPCH, equal to DwPTS and UpPTS above.
- A physical channel for random access, the Fast Physical Access CHannel (FPACH). FPACH is used by the Node B to carry, in a single burst, the acknowledgement of a detected signature with timing and power level adjustment indication to a UE.
- A 5ms TTI (Transmission Time Interval) is also introduced

On the other hand, two physical channels of 3.84 Mcps TDD, SCH and PNBSCH, are not needed in LCR option.

The transport and logical channels do not change.

Only one burst type is used. Transmit method of TFCI, TPC, SS, different basic midamble sequences and different timeslot formats differ compared to R99 TDD.

### **Multiplexing and Channel Coding**

Comparing to High Chip Rate TDD, there is a subframe segment block located after the second interleaving module and before the physical channel mapping module. The physical channel mapping stratagems and TFCI mapping and coding are also different.

### **Modulation and spreading**

While 3.84 Mcps TDD uses QPSK, LCR TDD can support 8PSK and QPSK, together with different combination scheme of downlink and uplink physical channel from UTRA TDD. 64 chips of a SYNC-DL sequence have been used for DwPTS and 128chips of a SYNC-UL sequence have been used for UpPTS, and there is a fixed relationship between the SYNC-DL sequence and the SYNC-UL sequence.

### **Physical layer procedures**

Uplink Synchronisation is realised in completely different ways in the two TDD modes. In LCR TDD, the UL synchronisation replaces the timing advance function performed by higher layer interaction in HCR TDD. In LCR, it can be considered as part of the random access procedure, as shown in the “Basic behaviour” section.

To minimise interferences, a closed loop Power control (as for the FDD mode) is introduced, with cycles from 0 to 200 cycles/sec.

### **Physical Layer Measurements**

Two new parameters are introduced: Timing Advance ( $T_{ADV}$ ) and Received SYNC-UL Timing Deviation. The other parameters measured are similar to those of UTRA TDD.

## **3.1.3 Layer 2 and Layer 3**

The changes on the Physical Channels imply new parameters and information elements (IEs) in the radio related protocols.

In RRC messages, the IEs referring to common physical channels had to be updated to cover both TDD chip rate options. New IEs are needed for FPACH, DwPCH and 5ms TTI. 3.84Mchips TDD and FDD and LCR TDD conduct similarly with respect to the following aspects: UE procedures in idle mode, Interlayer procedures in connected mode, Control plane protocol aspects, User plane protocol aspects, mobility aspects. Timing handling function is now performed at Layer 1 with the UL synchronization procedure, providing higher accuracy. Thus timing advance as a Radio Resource Control Protocol (Layer 3) is not needed.

The different aspects of LCR TDD layer 2 and layer 3 protocol aspects are as follows:

The MAC layer controls the RACH transmission by a two step procedure. More precisely, it:

- 1) Selects an ASC from the available set of ASCs
- 2) Initiates PRACH transmission procedure (L1 starts with SYNC\_UL/FPACH power ramping sequence)
- 3) Waits for access information from L1

- 4) Requests data transmission when receiving the indication “ready for RACH data transmission” from physical layer
- 5) Indicates successful completion of the MAC procedure to high layer

Concerning the RRC layer, LCR TDD uses the same messages as HCR TDD. Some IEs referring to special physical channel are introduced. The close power control, function offered by RRC, implies DPCH and PDSCH in 1.28Mchips TDD.

### 3.1.4 UE radio access Capability

The main difference between LCR and HCR TDD concerning UE radio access capabilities relates to the physical channel parameters, as shown in the tables below. The description of other aspects, e.g. PDCP parameters, RLC parameters, Transport channel parameters, Multi-mode related parameters, Multi-RAT related parameters, security parameters, UE positioning related parameters, are the same in both options. Compressed mode is not to be used in 1.28Mchips TDD.

**LCR TDD physical channel parameters in downlink**

<b>Maximum number of timeslots per subframe</b>	Defines the maximum number of timeslots per subframe that the UE can receive.
<b>Maximum number of physical channels per subframe</b>	This parameter defines how many physical channels can be received during one subframe. The distribution of the received physical channels on the received timeslots can be arbitrary.
<b>Minimum SF</b>	Defines the minimum spreading factor supported by the UE.
<b>Support of PDSCH</b>	Defines whether PDSCH is supported or not.
<b>Maximum number of physical channels per timeslot</b>	This parameter defines how many physical channels can be received within one timeslot.
<b>Support of 8PSK</b>	Defines whether 8PSK modulation is supported or not.

**LCR TDD physical channel parameters in uplink**

<b>Maximum Number of timeslots per subframe</b>	Defines the maximum number of timeslots per subframe that the UE can transmit.
<b>Maximum number of physical channels per timeslot</b>	Defines the maximum number of physical channels transmitted in parallel during one timeslot.
<b>Minimum SF</b>	Defines the minimum SF supported by the UE.
<b>Support of PUSCH</b>	Defines whether PUSCH is supported or not.
<b>Support of 8PSK</b>	Defines whether 8PSK modulation is supported or not.

### 3.1.5 Iub/Iur protocol aspects

To support the physical channel parameters as modified by LCR, some adaptations have been made on the Information Elements in radio link related signalling for Iub and Iur interfaces. This implies new parameters and IEs in the radio related protocols.

In NBAP and RNSAP messages, the IEs referring to time slot information, burst types, and common physical channels were updated to cover both TDD chip rate options.

### 3.1.6 Measurement and testing of radio propagation

Bandwidth and noise figure between LCR TDD and 3.84Mcps TDD are different. Besides, differences exist on physical layer frame structure and feature, e.g. Physical Channels and Mapping of Transport Channels onto Physical Channels, Multiplexing and Channel Coding, Modulation and spreading, Physical layer procedures and Physical Layer Measurements. These above cause differences on UE and BS RF radio transmission and reception, performance requirements, BS conformance testing, BS Electromagnetic compatibility and requirements for support of Radio Resource Management. So LCR TDD has its performance requirements on corresponding aspects described above to adapt its unique bandwidth and physical layer features.

### 3.1.7 Interworking with GERAN

Although the handover and the Cell Selection / Reselection to the low chip rate TDD are very similar to their 3.84 Mcps equivalents, there are some differences, e.g. modification of the system broadcast and

measurement report, which are described and clarified. Basically, most of them were originated from the differences of physical layer between low chip rate TDD and 3.84 Mcps TDD.

### 3.2 UTRA FDD Repeater Specification

**Acronym:** RInImp-REP  
**UID:** 1509  
**Main responsibility:** RAN WG4

References for WI " UTRA FDD Repeater Specification "	
Document	Title/Contents
RAN_Work_Items_History	WI Description
R4-00012	Repeater Feasibility Study
<b>Impacted Specifications</b>	
TS 25.113	Base station and repeater electromagnetic compatibility (EMC)
<b>New Dedicated Specifications</b>	
TS 25.106	UTRA repeater radio transmission and reception
TS 25.143	UTRA repeater conformance testing

A repeater is a device that receives, amplifies and transmits the radiated or conducted RF carrier both in the downlink direction (from the base station to the mobile area) and in the uplink direction (from the mobile to the base station).

The repeater converts the signal down to IF (Intermediate Frequency), amplifies and filters it and converts it back to RF. The repeater does not process the signal in base band hence it cannot decode any information. For this reason, UTRA TDD repeaters have been considered out of scope: without the information contained in the signalling, the repeater cannot know when to transmit in each direction, uplink or downlink.

Repeaters have been used in 2G networks as a cost effective solution for extending coverage in sparsely populated areas or environments with particular propagation conditions such as buildings, tunnels, subways, stadiums, etc.

The following figure shows a simple schema of the use of a repeater.

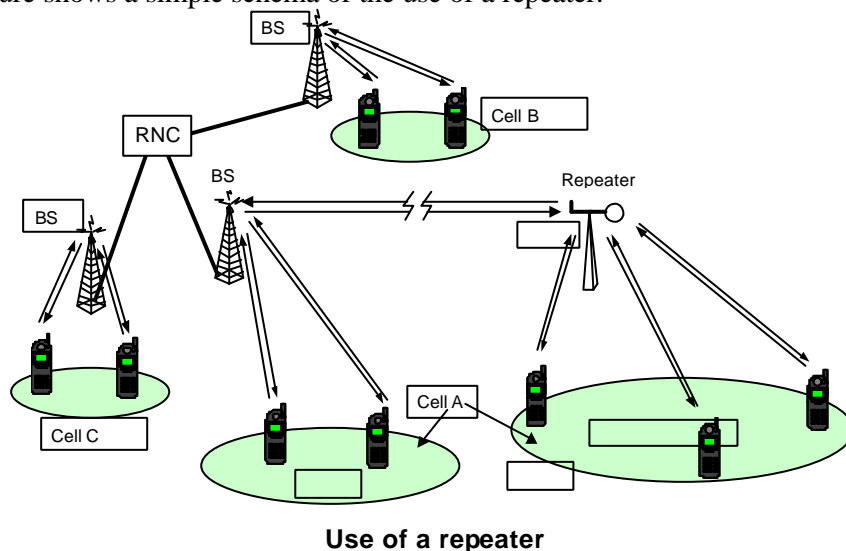

In the frame of this work, two new specifications are produced. TS 25.106 contains a set of Radio requirements for repeaters, and TS 25.143 specifies how this requirements should be tested. The following parameters are defined in Release 4:

- 1) Maximum output power: this is the difference between the actual power and the manufacturer's rated power. It has to be noted that 3GPP does not specify Maximum TX powers, this is a matter of national regulation.

- 2) Frequency stability, which is the frequency deviation of the output signal with respect to the input signal
- 3) Out of band gain: the undesired amplification of signals out of the operation band of the repeater.
- 4) Unwanted emissions. There are two set of limits: Out of band emissions, for the frequencies immediately outside the operating band; and Spurious emissions, from 9 KHz to 12,75 GHz. For the latter, particular requirements are specified for the cases of co-existence with various technologies (GSM, UTRA TDD, ...)
- 5) Modulation accuracy, to ensure that the quality of the source signal is not degraded by the additional processing in the repeater. There are two requirements: Error Vector Magnitude and Peak Code-Domain error
- 6) Input Intermodulation: the interference generated in the operating band in the repeater as a result of the presence of interfering signals on frequencies other than the operating band shall be less than a certain limit.
- 7) Output Intermodulation. This is a similar requirement as above, but in this case the interfering signals reach the repeater through the output port.

These requirements are roughly based on FDD Base Station requirements, only 3) and 7) address issues related to the operation of Repeaters. Notably, undesired interference or amplification in adjacent bands which might belong to a different network operator. Additional requirements are added in later Releases, as the particularities of operation of repeaters in a WCDMA network become evident.

The use of repeaters in the radio access is transparent to upper layers. However, there is an impact in the OTDOA method used in Location Services due to an increase in the path delay not originated by an increase in distance.

## 4 GSM-only new Features

### 4.1 700 MHz spectrum support

**Acronym:** 700SS  
**UID:** 2403  
**Main responsibility:** GP

**References for WI " 700 MHz spectrum support "**

Document	Title/Contents
GP-000449	WI Description
<b>Impacted Specifications</b>	
TS 51.010	Mobile Station (MS) conformance specification; Part 1: Conformance specification
TS 51.021	Base Station System (BSS) equipment specification; Radio aspects
TS 43.022	Functions related to Mobile Station (MS) in idle mode and group receive mode
TS 43.030	Radio network planning aspects
TS 44.018	Radio Resource Control (RRC) protocol
TS 24.008	Core network protocols; Stage 3
TS 45.001	Physical layer on the radio path; General description
TS 45.005	Radio transmission and reception
TS 45.008	Radio subsystem link control
<b>New Dedicated Specifications</b>	
	None

Contains:

2404	GERAN support for the 700 MHz band	GP-000450
2408	GERAN MS Conformance test for 700 MHz band	GP-000451
2410	GERAN BTS Conformance test for 700 MHz band	GP-000452

This feature provides GERAN system support for 700 MHz frequency band.

The commercial use of the 746-764 MHz and 776-794 MHz bands may be launched by US operators who have shown interest to provide GSM services on those new bands. In order to be one candidate technology to be used as a cellular service for those bands, the GSM specifications are now including the support of the so-called 700 MHz spectrum.

This was widely facilitated by the band independent format of GSM specifications: almost all aspects, as Service, MMI, Charging or Security aspects, are the same as in other bands (400, 850, 900, 1800 and 1900 MHz bands).

When considering GSM for the 700 MHz band, potential extension on further frequency bands like 430-450 MHz, 698-746 MHz, 1710-1885 MHz, 2500-2690 MHz was considered, e.g. in the channel numbering.

## 5 Improvements of UMTS and GSM pre-Release 4 features

### 5.1 Multimedia Messaging Service

**Acronym:** MMS  
**UID:** 1818  
**Main responsibility:** T2

**References for WI " Multimedia Messaging Service "**

Document	Title/Contents
TP-000078	WI Description
<b>Impacted Specifications</b>	
TS 22.140	Multimedia Messaging (MMS) stage 1
TS 23.140	Multimedia Messaging (MMS) stage 2/3
<b>New Dedicated Specifications</b>	
	None

The Multimedia Messaging Service (MMS) was first introduced in Release 99. It allows users to send and receive messages exploiting a large array of media types e.g. text of almost unlimited length, images, audio and video clips, while also making it possible to support new content types as they become popular. Multiple media elements can be combined into a composite single message. Messages can be sent either to a mobile phone or to an e-mail address.

The main network element of the Multimedia Message Service Environment (MMSE) is the MMS Relay/Server which is responsible for storage and handling of incoming and outgoing messages and for the transfer of messages between different messaging systems. Beside these tasks, the MMS Relay/Server has many other tasks which are described in TS 23.140. Other involved MMS elements are the MMS User Agent and MMS User databases. The functional descriptions of the involved MMS elements are provided in TS 23.140 and for implementation of the MMS User Agent – MMS Relay/Server interface a reference to the WAP Implementation of MMS is given. Whereas the Release 99 specifications only included the concept with some little technical details, the Release 4 document was enhanced significantly.

The figure below shows the MMS reference architecture and identifies the reference points.

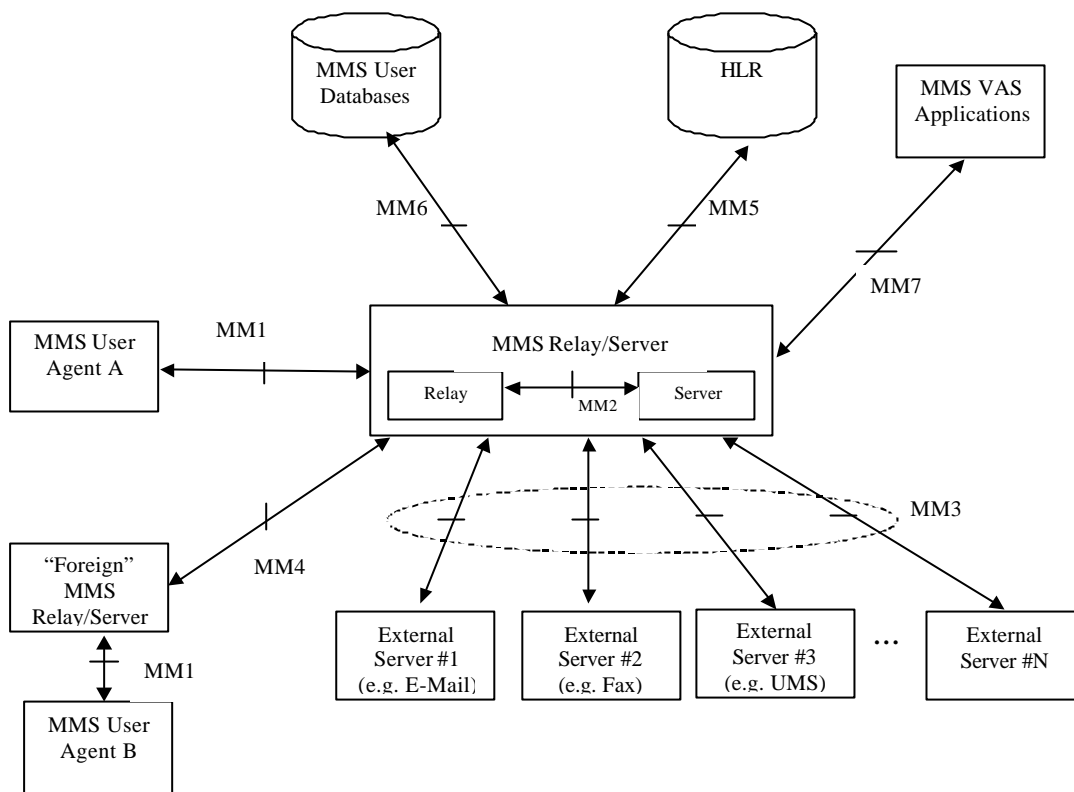

**MMS reference architecture**

The main improvement of MMS in Release 4 is the full definition of an operable MMS, including the MMS Service Behaviour Description, the Reference Architecture as shown above, the MMS framework, the application protocol framework and service primitives, and the Technical realisation of MMS, including the handling of MMS-related information on the USIM.

To enable interoperability of MMS between terminals and MMS network equipment of different manufacturers, the definition of a minimum set of mandatory media formats for the MMS User Agent was introduced. It included AMR for media type Audio, and Baseline JPEG for media type Image. The optional support of several more codecs is specified.

The support of the following aspects were added :

- streaming in MMS, enabling an MMS to trigger a streaming session.
- prepaid services in MMS
- sender's address hiding
- SMS over MMS. For this, the encapsulation of a short message in a multimedia message was specified.

The other aspects of Release 4 MMS are:

- The service behaviour description and the technical realization of Delivery-report and Read-reply report were introduced.
- As implementation examples for the MM1 interface between MMS User Agent and MMS Relay/Server, WAP implementation and IP implementation of MMS were added as Annexes.
- The reply-charging feature was added. This allows a user to take over the charge for the sending of a reply-MM to their submitted MM from the recipient(s). The originating MMS User Agent may define a reply-charging limitation request (e.g. may specify the latest time of submission of the reply-MMs or a maximum size of reply-MMs).
- The interworking with external servers (in particular IP-based) was further defined. An annex was added giving guidance on MM3 principles.
- The addressing scheme was further elaborated.

- The ability of forwarding MMs without prior download was inserted.
- The interface MM7 between the MMS Relay/Server and the MMS VAS Applications was added to the reference architecture. (It has to be noted that the detailed stages 2 and 3 descriptions were provided only in Rel-5)
- An example of Integration with Unified Messaging System (UMS) was added as an annex.
- Charging enhancements: An annex was added describing information of MMs/abstract messages which may be required for inclusion into Call Data Records (CDRs) for MMS for the purpose of Billing and Traceability.

## 5.2 MExE enhancements Rel-4

**Acronym:** MExE  
**UID:** 1445  
**Main responsibility:** T2

**References for WI " MExE enhancements Rel-4 "**

Document	Title/Contents
TP-030052	WI Description
<b>Impacted Specifications</b>	
TS 22.057	Mobile Execution Environment stage 1
TS 23.057	Mobile Execution Environment stage 2
<b>New Dedicated Specifications</b>	
	None

The work item MExE enhancements Rel-4 consists of two aspects:

- MExE Rel-4 Improvements and Investigations: several enhancements are introduced in Release 4 of which the most significant ones are mentioned in the MExE description below
- MExE Security Analysis Activity: this task was suggested to carry out an analysis of the MExE security framework and evaluate if it is sufficient to eliminate the risks posed by downloading content and applications. This analysis was performed by SA3 (Security) in co-operation with T2-MExE group.

MExE is a feature introduced in GSM Release 98, enhanced in GSM Release 99 to cover SIM MExE certificate management, security clarifications and QoS aspects. Release 4 introduces further enhancements of which the most significant is the introduction of a new small footprint Java classmark (Classmark 3).

MExE provides a standardised execution environment in an MS, and an ability to negotiate its supported capabilities with a MExE service provider, allowing applications to be developed independently of any MS platform. The MS can then be targeted at a range of implementations for MExE from small devices with low bandwidth, limited displays, low processor speeds, limited memory and MMI to sophisticated devices with a complete MExE execution environment.

A standardised means of negotiating the MSs' and network's capabilities is supported. This negotiation permits the mutual exchange of capabilities between the MS and the MExE server, and possibly includes the service profile of the user and capabilities of the network.

A network can be a transport bearer for the negotiation, interaction and transferring of applications, applets and content with the MS. It does not have to be the provider of the MExE services with which the MS's execution environment is interacting with. The network may also be the intermediary between two MSs which are engaged in a MExE service with each other, with the network effectively supplying the "pipe" and not playing a MExE role in the connection. Network nodes, nodes external to the network, or even MSs are the entities which can interact with the MSs' execution environment.

Central elements of the MExE specification are the classmark concept, content negotiation and the security architecture which are explained below.

The MExE classmark provides the device's capabilities. The following classmarks are defined in Release 4 (in Rel-4 MExE classmark 3 was added):

- MExE classmark 1 - based on Wireless Application Protocol (WAP) - requires limited input and output facilities (e.g. as simple as a 3 lines by 15 characters display and a numeric keypad) on the client side, and is designed to provide quick and cheap information access even over narrow and slow data connections.
- MExE classmark 2 - based on Personal-Java - provides and utilises a run-time system requiring more processing, storage, display and network resources, but supports more powerful applications and more flexible MMIs. MExE Classmark 2 also includes support for MExE classmark 1 applications (via the WML browser.)
- MExE classmark 3 – based on J2ME CLDC and MIDP environment – supports Java applications running on resource-constrained devices. Classmark 3 MExE devices are based on the Connected Limited Device Configuration (CLDC) with the Mobile Information Device Profile (MIDP). Java 2 Micro Edition (J2ME) is a version of the Java 2 platform targeted at consumer electronics and embedded devices. CLDC consists of a virtual machine and a set of APIs suitable for providing tailored runtime environments. The J2ME CLDC is targeted at resource constrained connected devices (e.g. memory size, processor speed etc.)

Content negotiation allows for flexible choice of formats available from a server or adaptation of a service to the actual classmark of a specific client device. Bi-directional capability negotiation between the MExE Service Environment and MExE device (including MExE classmark), supports the transfer of capabilities between the client and the server.

In order to manage the MExE and prevent attack from unfriendly sources or transferred applications unintentionally damaging the MExE device a security architecture is specified. The basis of MExE security is:

- a framework of permissions which defines the permissions transferred MExE executables have within the MExE MS;
- the secure storage of these permissions and permission types;
- conditions within the execution environment that ensure that MExE executables can only perform actions for which they have permission.

The MExE permissions framework is as follows (there is no implied hierarchy):

- MExE Security Operator Domain (MExE executables authorised by the HPLMN operator);
- MExE Security Manufacturer Domain (MExE executables authorised by the terminal manufacturer);
- MExE Security Third Party Domain (trusted MExE executables authorised by trusted third parties);
- Support for the three domains is mandatory;

Untrusted MExE executables are not in a specific domain, and have very reduced privileges.

In Release 4 several enhancements to the security framework have been introduced in particular enhancements related to the new MExE classmark 3 based on J2ME CLDC and MIDP.

Another enhancement in Release 4 is the optional support of core software download. Core software download enables the UE radio, characteristics and properties to be updated by changing the software in the UE. E.g. a new codec may be loaded into a device, a new air interface, etc. Guidelines are introduced into the specification but the functionality is not specified in detail.

## 5.3 Advanced Speech Call Items enhancements\_REL-4

**Acronym:** ASCII



**UID:** 2230  
**Main responsibility:** CN1

**References for WI " Advanced Speech Call Items enhancements\_REL-4 "**

Document	Title/Contents
NP-000730	WI Description on ASCI Release 4 enhancements
<b>Impacted Specifications</b>	
TS 43.068 TS 43.069 TS 44.068 TS 44.069 TS 24.008	Voice Group Call Service (VGCS); Stage 2 Voice Broadcast Service (VBS); Stage 2 Group Call Control (GCC) protocol Broadcast Call Control (BCC) protocol Mobile radio interface Layer 3 specification; Core network protocols; Stage 3
<b>New Dedicated Specifications</b>	
	None

This work item was introduced mainly for maintenance of the ASCI feature. ASCI refers to the use of GSM for Railways (GSM-R).

The Release 4 enhancements cover ASCI's High Speed Train Interoperability, as requested by the TSI (Technical Standards for Interoperability).

The enhancements are the possibility to add operator-to-dispatcher information, the definition of ASCI related event records, and the introduction of ciphering for Voice Group Call Service (VGCS)/Voice Broadcast Service (VBS).

## 5.4 Rel-4 Evolutions of the transport in the CN

**Acronym:** CNTRSP (for "CN Transport")  
**UID:** 400004  
**Main responsibility:** CN4

**References for WI " Rel-4 Evolutions of the transport in the CN "**

Document	Title/Contents
NP-000746	#7 Signalling over IP in Core Network
<b>Impacted Specifications</b>	
TS 29.002 TS 29.078 TS 29.018 TS 29.016	Mobile Application Part (MAP) specification CAMEL Application Part (CAP) specification Gs interface layer 3 specification (BSSAP+) Gs interface Layer 2 specification
<b>New Dedicated Specifications</b>	
	None

IP plays a significant role in UMTS according to the actual trend towards IP-capable backbone networks. This feature refers to the introduction of IP-based transmission in a Bearer Independent Core Network, so that the transfer of #7 signalling (e.g. MAP, CAP, BSSAP+) over IP is supported.

Within IETF, the group SIGTRAN has defined the Internet Drafts describing this functionality. The architecture defined by SIGTRAN (RFC 2719) consists of a modular extensible structure with a common reliable transport protocol SCTP (RFC 2960). SCTP (Stream Control Transmission Protocol) is an application level datagram transfer protocol operating on top of IP. In order to access SCTP an adaptation module has been defined between the SCN (Switched Circuit Network) signalling system being carried and SCTP. The adaptation module allows keeping the signalling protocol unchanged.

In 3GPP, the option to allow the transfer in the Core Network of the #7 signalling (e.g. MAP, CAP, BSSAP+) over IP is done according to the architecture defined by SIGTRAN (RFC 2719) with the SCTP layer (RFC 2960) and the appropriate adaptation layer. Impacts to the higher layer protocols TC and MAP have been avoided as much as possible.

## 5.5 Rel-4 Emergency call enhancements

**Acronym:** EMC1  
**UID:** 401652, 1654  
**Main responsibility:** N1

References for WI " Rel-4 Emergency call enhancements "	
Document	Title/Contents
NP-010136	CS based Emergency Call Enhancements in Rel-4
<b>Impacted Specifications</b>	
TS 24.008	Mobile radio interface Layer 3 specification; Core network protocols; Stage 3
<b>New Dedicated Specifications</b>	
	None

Emergency calls over the CS domain has been integrated into the system as a mandatory feature from the beginning of GSM. As imposed by new national regulations, this feature enhances this service by enabling emergency calls to be triggered without dialling the emergency number, as this number varies between networks and might create failures in roaming cases. Instead, other means such as menu and/or linkage to external security devices, as a car air bag, will trigger the call. The default numbers are stored in the ME and/or USIM. If the numbers are stored in ME, this functionality is also supported by the UE without a SIM/USIM being present.

Emergency calls was intended to work in the CS and the PS domain, but the packet emergency calls was not implemented in Release 4 and became a work item for Rel-5 where that part was enhanced to include IMS.

## 5.6 Rel-4 Terminal interfaces

The Feature Rel-4 Terminal Interfaces consists of the following three independent functionalities which are described in the following sections :

- AT commands enhancements
- Wide Area Data Synchronization
- Terminal local model

### 5.6.1 AT-commands enhancements

**Acronym:** TI-ATC  
**UID:** 1827  
**Main responsibility:** T2

References for WI " AT commands enhancements "	
Document	Title/Contents
	No WID
<b>Impacted Specifications</b>	
TS 27.007	AT command set for User Equipment (UE)
<b>New Dedicated Specifications</b>	
	None

This work item is about AT<sup>6</sup> commands for control of 3GPP Mobile Equipments (MEs) via an external Terminal Equipment (TE), fully compatible with GSM AT commands.

---

<sup>6</sup> AT: ATtention; this two character abbreviation is always used to start a command line to be sent from TE to TA. TE is the Terminal Equipment, e.g. a computer (equal to DTE; Data Terminal Equipment), TA is Terminal Adaptor, e.g. a GSM data card (equal to DCE; Data Circuit terminating Equipment)

TS 27.007 specifies a profile of AT commands and recommends that this profile be used for controlling ME functions and GSM network services from a TE through Terminal Adaptor (TA). The command prefix +C is reserved for Digital Cellular in ITU-T Recommendation V.25ter. This TS has also the syntax details used to construct these extended GSM commands. Commands from ITU-T Recommendation V.25ter and existing digital cellular standards (TIA IS-99 and TIA IS-135) are used whenever applicable. Some of the new commands are defined such way that they can be easily applied to ME of networks other than GSM.

The new AT commands added in Release 4 relate all to ASCII<sup>7</sup> services:

- Introduction of a new AT command +CUUS1 to manage User-to-User Information element
- Indication of priority and/or sub-address in the unsolicited result code CCWA
- eMLPP SIM Commands
- VBS, VGCS SIM Commands
- Extension of dial command for VBS and VGCS
- Introduction of a new AT command +COTDI to manage Originator-to-dispatcher information element

## 5.6.2 Wide Area Data Synchronisation

**Acronym:** TI-WADS  
**UID:** 1829  
**Main responsibility:** T2

References for WI " Wide Area Data Synchronisation "	
Document	Title/Contents
	No WID
<b>Impacted Specifications</b>	
TR 27.903	Discussion of synchronisation standards
TS 27.103	Wide Area Network Synchronisation
<b>New Dedicated Specifications</b>	
	None

In Release 99, the concept of Wide Area Synchronisation for 3GPP has been developed to allow data stored in the ME/USIM to be synchronised with the outside world. In Release 4, SyncML was introduced as the preferred synchronisation mechanism replacing IrMC level 4.

TR 27.903 provides information on existing synchronisation protocols. It summarises proprietary and standard protocols relevant to current and future mobile communication devices. The document covers only synchronisation between end-user devices, desktop applications, and server-based information services. It does not refer to replication or synchronisation between enterprise databases.

This specification provides a definition of a Wide Area Synchronisation protocols. The synchronization protocol was originally based upon IrMC level 4 in Release 99 which was replaced by SyncML in Release 4. The document covers Wide Area Network Synchronisation between current and future mobile communication end-user devices, desktop applications and server-based information servers.

SyncML is an XML-based specification for data synchronization. It accommodates not only traditional local synchronization but also the special requirements associated with remote synchronization in wide-area wireless environments with intermittent connectivity. SyncML is based on a client-server model. SyncML specifications consist of three major components: representation protocol, synchronization protocol, and transport bindings. The Representation protocol defines XML-based messages for synchronization, whereas the Synchronization protocol defines synchronization in the form of message sequence charts. The Transport binding specification defines a mechanism to carry synchronization messages over different transport mechanisms.

<sup>7</sup> ASCII: Advanced Speech Call Items, including Voice Group Call Service (VGCS), Voice Broadcast Service (VBS) and Enhanced Multi-Level Precedence and Pre-emption Service (eMLPP)

## 5.6.3 Terminal Local Model

**Acronym:** TLM  
**UID:** 1832  
**Main responsibility:** T2

**References for WI "Terminal Local Model"**

Document	Title/Contents
TP-000080	WI Description
<b>Impacted Specifications</b>	
TS 23.227	Application and User interaction in the UE - Principles and specific requirements
<b>New Dedicated Specifications</b>	
	None

The rapid development of a diversity of new applications and application environments for mobile usage creates a complexity of previously unseen proportions that the Mobile Equipment has to handle. Since third party software can run in various parts of the UE, there was a need to develop a general framework to ensure that the APIs created for the different UE-based toolkits work in harmony with each other.

The work item introduces such a generic model approach for the UE environment; the purpose is *not* to categorise the applications peripherals, but to try to structure the events that are internal and external to, and has to be handled by, the MT Core Functions. This means that the structure or grouping of the events is done from a *MT centric* perspective. Some applications run on the UE side have counterparts in the network. The functions in the network are not addressed in this work.

Under this work item the principles were defined for scheduling resources between applications in different application execution environment (e.g. MExE, USAT etc.) and internal and external peripherals (e.g. infra-red, Bluetooth, USIM, radio interface, MMI, memory etc.).

## 5.7 Rel-4 Location Services enhancements

### 5.7.1 General aspects

**Acronym:** LCS1  
**UID:** 401536  
**Main responsibility:** S2

**References for WI " Rel-4 Location Services enhancements "**

Document	Title/Contents
SP-010518	WI Description
<b>Impacted Specifications</b>	
TS 25.305	LCS Stage 2 (UTRAN part)
<b>New Dedicated Specifications</b>	
TS 23.271	LCS Stage 2 (CN part)
TS 43.059	LCS Stage 2 (GERAN part)

Between Rel99 LCS and Releases 4 LCS, the main difference concerns the documentation: the Stage 2 documents are restructured, as shown in the figure below.

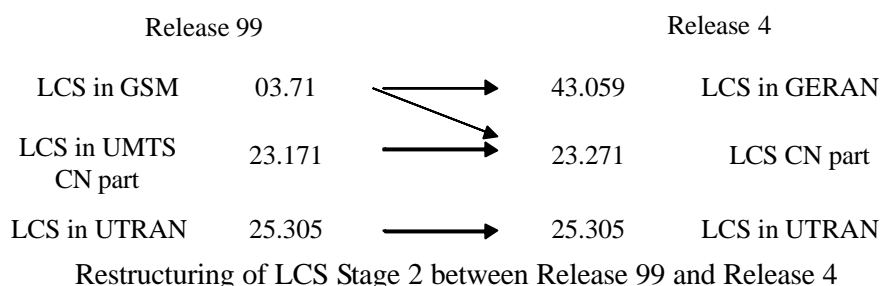

From a functionality point of view, Release 99 and Release 4 LCS are practically identical. The main difference is that the support of OTDOA method in LCR TDD mode is introduced in Release 4, as LCR TDD itself is introduced in this Release (see corresponding description in this document).

Also in Rel 4, the "Deferred Location Request" is introduced: in response to this request, the location is provided to the LCS client as soon as the target mobile becomes reachable again. Deferred answers triggered by other types of events are also considered, but are not standardised in this Release (not even in Release 5).

Lastly, new OSA APIs (Application Programming Interface for Open Access Service) are defined for the LCS.

## 5.7.2 Iub/Iur interfaces for UE positioning methods supported on the radio interface Release 99 (applicable only to UMTS)

**Acronym:** LCS1-UEpos-IubIur  
**UID:** 1601  
**Main responsibility:** R3

### References for WI "Iub/Iur interfaces for UE positioning methods supported on the radio interface Release 99 "

Document	Title/Contents
RP-000509	WI Description on "Iub/Iur interfaces for methods Rel 99"
<b>Impacted Specifications</b>	
TS 25.401	UTRAN Overall Description
TS 25.420	UTRAN Iur Interface: General Aspects and Principles
TS 25.423	UTRAN Iur Interface RNSAP Signalling
TS 25.430	UTRAN Iub Interface: General Aspects and Principles
TS 25.433	UTRAN Iub Interface NBAP Signalling
<b>New Dedicated Specifications</b>	
TR 25.850	UE positioning in UTRAN Iub/Iur protocol aspects

Several methods for UE positioning<sup>8</sup> are supported on the radio interface in Release 99:

- cell coverage based positioning method;
- OTDOA method with network configurable idle periods and
- network assisted GPS method.

Nevertheless, only the cell coverage based positioning method is supported on the Iub and Iur interface of Release 99.

In Release 4, the necessary support for the other positioning methods defined for Release 99 were added to the Iub and Iur protocols, hence the discrepancy between the name of this functionality and the Release to which it applies.

## 5.8 Rel-4 UICC/(U)SIM enhancements and interworking

**Acronym:** UICC1  
**UID:** 401560  
**Main responsibility:** T3

<sup>8</sup> "UE positioning" refers to the Access Network part of LCS.

### References for WI " Rel-4 UICC/(U)SIM enhancements and interworking "

Document	Title/Contents
TP-040116	WID on "Addition of CPHS features", WID on "Enhancements to 03.48",
<b>Impacted Specifications</b>	
TS 22.101 TS 31.102 TS 51.011	Service aspects; Service principles Characteristics of the USIM Application Specification of the Subscriber Identity Module - Mobile Equipment (SIM-ME) interface
<b>New Dedicated Specifications</b>	
	None

#### 5.8.1 Addition of CPHS features

This item refers to the incorporation in the Release 4 Standard of some terminal and USIM functions which were previously defined in a stand-alone addendum to the 3GPP standard known as the “CPHS features”, “CPHS” meaning “Common PCN (Personal Communication Network) Handset Specification”. These functions were already available in some pre-Rel 4 equipments and have proven to be useful.

They consist of additions in the USIM of :

- A file called ‘EF<sub>PNN</sub>’ (PLMN Network Name) (corresponding to the CPHS file EF<sub>OpName</sub> (PLMN Operator Name)). This file enables to display the operator name instead of a network code.
- A file called ‘EF<sub>OPL</sub>’ (Operator PLMN List) to indicate for which Location Area Identities a required network name is to be displayed
- Mailbox numbers and “Message waiting” indicators. Several mailbox Numbers can be stored, one per type of message: Voicemail, Fax, Electronic Mail and Other messages. A short message may be used to indicate the status, types and number of waiting messages. The ME shall present this indication as an icon on the screen, or other MMI indication, and store the indication status on the SIM/USIM to allow the status to be retained through power off/on, SIM/USIM movement between UEs etc. The ME shall be able to accept and acknowledge these message waiting status short messages irrespective of the memory available in the SIM/USIM.

#### 5.8.2 Other aspects

WID on "Report on SIM/USIM interoperation" was approved for Release 4 and TR 31.900 was created, but withdrawn in TP#16 plenary meeting. TR 31.900 remains valid only in Rel-5.

### 5.9 Rel-4 (U)SIM toolkit enhancements

**Acronym:** USAT1  
**UID:** 401800  
**Main responsibility:** T3

#### References for WI " Rel-4 (U)SIM toolkit enhancements "

Document	Title/Contents
	No WI Description
<b>Impacted Specifications</b>	
TS 31.111 TS 51.014	Universal Subscriber Identity Module Application Toolkit (USAT) Specification of the SIM Application Toolkit for the Subscriber Identity Module - Mobile Equipment (SIM - ME) interface
<b>New Dedicated Specifications</b>	
TS 23.048	Security Mechanisms for the (U)SIM application toolkit in Rel-4

In Release 4, only one enhancement was added in the field of (U)SIM toolkit, also called (U)SAT or USAT (Universal SIM Application Toolkit). This is the “USAT Local Link”, which refers to the use of a local link (RS232, Bluetooth, USB, Irda) as a bearer for USAT.

This work extends the existing bearer independent functionality and allows a USAT application to communicate with local devices using the local connectivity capabilities of the terminal.

For applications dedicated to third party equipment, the knowledge of the local environment (attached devices) is useful. So a way for the USAT to get the local connection status, independent of the type of link, is also defined.

As some applications may require a secure link, security facilities offered by the bearer may be used, as well as an upper layer security mechanism. This is covered in the Rel-4 created TS 23.048 "Security Mechanisms for the (U)SIM application toolkit in Rel-4", replacing GSM 03.48. It contains following enhancements compared to Release 99 GSM 03.48:

- USIM input and output commands for Remote File Management (RFM)
- Clarification on computation of Data Encryption Standard (DES) in Cipher Block Chaining (CBC) mode
- Clarifications on Access Domain Parameter

To meet the Release 4 requirements, the storage of MMS related information in several elementary files on the SIM is introduced retroactively (affected specifications are TS 51.011 and TS 31.102).

## 5.10 Rel-4 Open Service Access (OSA) improvements

**Acronym:** OSA1  
**UID:** 401142  
**Main responsibility:** CN5

### References for WI "OSA improvements"

Document	Title/Contents
<b>WIDs</b>	
SP-000216 (S1-000447)	WI on Scope of Open Interface for Service Provision in Release 2000 (SA1)
SP-000302	OSA security (SA3)
<b>Impacted Specifications</b>	
22.121	Service aspects; The Virtual Home Environment; Stage 1
23.127	Virtual Home Environment (VHE) / Open Service Access (OSA); Stage 2
29.198	Open Services Architecture API part 1 (R99 was split in Rel-4 in a multi-part TS, see below)
29.998	Open Services Architecture API part 2 (R99 was split in Rel-4 in a multi-part TS, see below)
33.102	Security Architecture
<b>New Dedicated Specifications</b>	
22.127	Service Requirement for the Open Services Access (OSA); Stage 1
33.200	MAP Application Layer Security
<b>OSA API</b>	
29.198-01	Part 1: Overview
29.198-02	Part 2: Common data
29.198-03	Part 3: Framework
29.198-04	Part 4: Call control
29.198-05	Part 5: Generic user interaction
29.198-06	Part 6: Mobility
29.198-07	Part 7: Terminal capabilities
29.198-08	Part 8: Data session control
29.198-11	Part 11: Account management
29.198-12	Part 12: Charging
<b>OSA API Mapping for OSA</b>	
29.998-01	Part 1: General Issues on API Mapping
29.998-04-1	Part 4: Call Control Service Mapping; Subpart 1: API to CAP Mapping
29.998-05-1	Part 5: User Interaction Service Mapping; Subpart 1: API to CAP Mapping
29.998-05-4	Part 5: User Interaction Service Mapping; Subpart 4: API to SMS Mapping
29.998-06	Part 6: User Location and User Status Service Mapping to MAP
29.998-08	Part 8: Data Session Control Service Mapping to CAP

Open Service Access (OSA) allows service development by operators and third parties: it enables application developers to make use of network functionality through open, standardised, secure, extensible and scalable interfaces. Applications see the network functionality offered to them as a set of Service Capability Features (SCFs) in the OSA APIs. These SCFs provide access to the network capabilities on which the application

developers can rely when designing their applications. The OSA APIs are independent of where or which network capabilities are implemented in the network, and of vendor-specific solutions and programming languages.

This work (stage 1, 2 and 3 specifications) was done jointly with other fora (3GPP2, ETSI SPAN and Parlay), so that there is a single set of standard OSA APIs for the whole development community.

The objective of OSA in Release 4 is to enhance the OSA interface for the communication between Applications and Service Capability Features (SCF). The SCFs are described in the OSA set of specifications.

Release 4 brings enhancements to the OSA interface based on the evolved network capabilities within the Core Networks. Examples of these are:

- **Call Control (IP)**  
This addresses the Call Control capabilities based on SIP and/or H.323. In 3GPP, SIP is introduced only in Release 5 with the IMS (IP Multimedia Subsystem). However, it is justified to have the corresponding OSA capability as early as Release 4 because SIP and H323 exist in fixed networks for some time and the 3GPP OSA has a requirement to have the same API for Fixed and Mobile networks (and, more generally, to be network-agnostic).
- **E-Commerce**  
This takes into account the capabilities provided by the network to use the capabilities provided by the post processing of the charging capabilities (e.g. E-Pay). It also involves the enhancements of the security to be provided by the network and by the application.

The enhancements compared to OSA Release 99 are as follows:

- **User Location:** Further integration of the Location Services within the provisioning of geographical positioning information, taking into account the evolution of the 3G networks associated with this capability.
- **Terminal Capabilities:** In Release 99, the mechanism to retrieve the terminal capabilities is only applicable to WAP phones. Rel-4 adds a mechanism that is applicable to all types of phones. Security mechanisms for the display of terminal capabilities information have been added.
- **Enhanced User Profile Management:** The integration of the Personal Service Environment Management (PSEM) within the Network and Framework SCFs.
- **Enhanced Session Control:** This provides the enhancements of the bearer manipulation and creation of bearers/sessions sessions (in particular negotiation of the QoS).

The OSA API offer many capabilities related to charging (they supervise of user activities for online charging features; allow applications to access the online account; allow applications to add charging information to network based charging records; and inform applications on network based charging event).

## 6 Improvements of UMTS-only pre-Release 4 features

### 6.1 QoS Architecture for PS Domain

**Acronym:** QoS  
**UID:** 2546  
**Main responsibility:** S2

This chapter covers the following WIs:

<i>UID</i>	<i>Name</i>	<i>Group</i>	<i>Acronym</i>	<i>WID</i>
2548	Architecture	SA2		
2550	Charging and OAM&P for QoS Management	SA5	QoS- OAM	SP-010461
1681	RAB Quality of Service (re)Negotiation over lu	RAN3	QoS- MAPEND- RABQoS	RAN_Wis, RP-000499
2554	RAB QoS Renegotiation at Relocation	RAN3		



1685	PS-domain handover for real-time services	RAN3	QoS-PSdoRTS	RAN_Wis
1553	GERAN QoS Aspects - Handovers: maintenance of real-time QoS while moving between cells in the PLMN including inter-SGSN and SRNS relocation or possibly other mechanisms	GP	GERQoS	GP-010431
50010	GERAN MS Conformance test for inter-system and intra-system Packet data real-time Handover	GERAN4, RAN3	GERQoS-Mstest	GP-012287

The References for WI " UMTS QoS Architecture for PS Domain " given for each individual WI. The work done under UIDs 2548 and 2550 (SA2's architecture and SA5's Charging aspects) was only maintenance of pre-Release 4 concepts.

### 6.1.1 RAB Quality of Service (re)Negotiation

UIDs:

- 1681 for "RAB Quality of Service (re)Negotiation over Iu"
- 2554 for "RAB QoS Renegotiation at Relocation"

WIDs in:

- RP-000499 for "RAB Quality of Service Negotiation over Iu"
- RP-000500 for "RAB Quality of Service Renegotiation over Iu"
- RP-010168 for "RAB Quality of Service Negotiation over Iu during Relocation"

Affected specification: TS 25.413

#### 6.1.1.1 RAB Quality of Service Negotiation over Iu

In Release 99, UTRAN can only accept or reject a radio access bearer request from the core network. For services that could accept looser QoS requirements than those requested by the CN in the RAB establishment request, there exist no means for UTRAN to propose alternative (looser) QoS. For such services, the RAB establishment will fail, or alternatively the CN could re-attempt the RAB reestablishment with looser QoS requirements which would significantly increase the setup time.

In Release 4 the Radio Access Bearer setup is enhanced with a QoS negotiation mechanism. This aligns the procedure with the already existing CN solution used in GPRS and it improves the service setup time.

#### 6.1.1.2 RAB Quality of Service Renegotiation over Iu

Release 99 also does not allow the UTRAN to renegotiate RAB/QoS parameters for on-going calls/session. Since the UTRAN is responsible for managing the radio resources, it was seen necessary that the UTRAN is able to initiate RAB renegotiation for efficient use of the radio interface.

In Release 4 the management of Radio Access Bearers for on-going calls/session was enhanced such that QoS parameters can be renegotiated by the UTRAN

The intention is also to allow continuation of service through UTRAN initiated QoS renegotiation

#### 6.1.1.3 RAB Quality of Service Negotiation over Iu during Relocation

In Release 99, no means exists for the UTRAN to propose an alternative QoS for services that could accept looser QoS requirements than those requested by the CN in the relocation request.

In Release 4, the relocation is enhanced such that QoS parameters can be negotiated by the UTRAN during relocation.

### 6.1.2 PS-Domain handover for real-time services

WID in RP-000127

Affected RAN3 spec: 25.413

New dedicated TR: 25.936 (PS-Domain handover for real-time services)

In Release 99, Relocation for services from PS domain is only optimised for non-real-time services, as it was designed only for this type of services. The principle is that the N-PDUs are forwarded from the source RNC

buffers to the target RNC. Data buffering is not adapted to real-time services, and means that interruption may exceed the requirement for real-time services.

In Release 4 the relocation is optimised by utilising a N-PDU duplication mechanism in the RNC/BSS and the execution of relocation is performed after relocation resource allocation.

## 6.2 Rel-4 Evolutions of the transport in the UTRAN

**Acronym:** ETRAN  
**UID:** 400002  
**Main responsibility:** RAN

### 6.2.1 QoS optimization for AAL type 2 connections over Iub and Iur interfaces

References for WI " QoS optimization for AAL type 2 connections over Iub and Iur interfaces "

Document	Title/Contents
RP-010146	Final Status Report
RP-000188	WID: QoS optimization for AAL type 2 connections over Iub and Iur interfaces
<b>Impacted Specifications</b>	
TS 25.414	UTRAN Iu interface: data transport & transport signalling
TS 25.415	UTRAN Iu interface: user plane protocols
TS 25.420	UTRAN Iur interface: general aspects and principles
TS 25.424	UTRAN Iur interface: data transport & transport signalling for common transport channel data streams
TS 25.425	UTRAN Iur interface: user plane protocols for common transport channel data streams
TS 25.426	UTRAN Iur and Iub interfaces: data transport & transport signalling for DCH data streams
TS 25.430	UTRAN Iub interface: general aspects and principles
TS 25.434	UTRAN Iub interface: data transport & transport signalling for common transport channel data streams
TR 25.931	UTRAN functions, examples on signalling procedures
<b>New Dedicated Specifications</b>	
TR 25.934	QoS optimization for AAL type 2 connections over Iub and Iur interfaces

Traffic like compressed voice and data both use AAL type 2 connections. Over Iub and Iur interfaces, this traffic is accommodated as real time traffic, even for data, in common underlying Virtual Circuits for AAL type 2 connections. This is done to ease management of Connection Frame Number (CFN) allocation to downlink data frames and the scheduling at the Serving RNC.

But the drawback is that in Release 99, the network sections with AAL type 2 switches do not offer the capability to prioritise real time traffic over non-real time. They use ITU Recommendations I.363.2 and Q.2630.1 which do not offer such a capability.

In practice, meeting the delay requirements for voice is solved in Release 99 by introducing much higher capacity for underlying Virtual Circuits for AAL type 2 connections. The capacity has to be quite oversized to cover the most difficult case, where a (small) real time traffic frame arrives at the switch immediately after a (much bigger) non-real time traffic data frame.

But over sizing the Virtual Circuits for AAL type 2 connections over the Iub interface impacts widely the initial and running costs of the Iub interface, which usually consists of a leased line.

In Release-4, a "Path type capability" is introduced, as defined in ITU Recommendation Q.2630.2. This capability allows to optimise the bandwidth of underlying Virtual Circuits for AAL type 2 connections over Iub and Iur interfaces in addition to the scheduling capability at SRNC.

This work is done under the 3GPP name "QoS optimization for AAL type 2 connections over Iub and Iur interfaces" (ETRAN-QoSAAAL2).

## 6.2.2 Transport bearer modification procedure on Iub, Iur, and Iu

### References for WI " Transport bearer modification procedure on Iub, Iur, and Iu "

Document	Title/Contents
RP-010148	Final Status Report
RP-000446	WID: Transport bearer modification procedure on Iub, Iur, and Iu (originally Migration to Modification procedure
<b>Impacted Specifications</b>	
TS 25.410	UTRAN Iu interface: data transport & transport signalling
TS25.413	UTRAN Iu interface: user plane protocols
TS 25.414	UTRAN Iur interface: general aspects and principles
TS 25.420	UTRAN Iur interface: data transport & transport signalling for common transport channel data streams
TS 25.424	UTRAN Iur interface: user plane protocols for common transport channel data streams
TS 25.426	UTRAN Iur and Iub interfaces: data transport & transport signalling for DCH data streams
TS 25.430	UTRAN Iub interface: general aspects and principles
TS 25.434	UTRAN Iub interface: data transport & transport signalling for common transport channel data streams
TR 25.931	UTRAN functions, examples on signalling procedures
<b>New Dedicated Specifications</b>	
TR 25.954	Transport bearer modification procedure on Iub, Iur, and Iu

In Release 99, a radio access bearer can be modified only by establishing a new bearer and releasing the old one. This is not very efficient, but no modification message exists.

In Release 4, a modification procedure is introduced. This is functionally less complex than the Release 99 solution, and much less signalling messages are needed.

## 6.3 Rel-4 Improvements of Radio Interface

This feature was designed as a collection of independent improvements of the Radio Interface. At the end of Release 4, it appears that the collection was reduced to one single item, "DSCH power control improvement in soft handover" described below. However, as to avoid purely administrative work, the structure was kept as such.

### 6.3.1 DSCH power control improvement in soft handover

**Acronym:** RInImp-DSCHsho  
**UID:** 1994  
**Main responsibility:** RAN1

## References for WI " DSCH power control improvement in soft handover "

Document	Title/Contents
RAN_Work_Items_History	WI Description
<b>Impacted Specifications/ TRs</b>	
TS 25.211	Physical Channels and mapping of transport channels to physical channels (FDD)
TS 25.214	Physical Layer Procedures (FDD)
TS 25.331	RRC Protocol Specification
TS 25.423	UTRAN Iur Interface RNSAP Signalling
TS 25.433	UTRAN Iub Interface NBAP Signalling
<b>New Dedicated Specifications</b>	
TR 25.841	DSCH power control improvement in SHO
TR 25.849	DSCH power control improvement in soft handover (Iub & Iur aspects)

In Release 99, DSCH (Downlink Shared Channel) power control is based on the TPC commands sent by the UE on the uplink DPCCH (Dedicated Physical Control Channel) for the control of the dedicated channel. In soft handover, the node B transmitting DSCH may appear to the UE as one of the weak, and the associated DCH from that node B will not be the basis for the power control commands generated by the UE. Using this commands to control the DSCH will result in a random power control.

DSCH power control in soft handover can be improved by the use of the existing SSTD (Site Selection Diversity TPC) signalling in the uplink.

SSTD is a Release 99 baseline feature. In soft handover, the UE provides indication in the uplink of which of the cells in the active set is the strongest (primary cell), and then only the primary cell sends the DPDCH part of the downlink DCH, while DPCCH part is still sent by the all Node Bs in the active set

The feature uses SSTD signalling to determine whether DSCH power should follow the DCH (primary cell transmitting) or whether the DSCH power should be set with higher offset in case secondary cell is transmitting.

Modifications to the specifications are required as follows:

- Layer 1 DSCH power control, to allow it to be independent of its associated DCH and commanded by the SSTD status of the node B.
- Site Selection Diversity Transmit, to allow the SSTD signalling in the uplink even if the SSTD is not active in the downlink.
- Iub & Iur protocols (NBAP & RNSAP): new IEs to implement the enhanced DSCH and the commands from the RNC to the Node B to set the offset in power between the DSCH and its associated DCH.

## 6.4 Rel-4 RAN improvements

**Acronym:** RANimp  
**UID:** 400009  
**Main responsibility:** RAN

This feature contains two independent items described in the next two sections.

### 6.4.1 Node B synchronisation for TDD

**Acronym:** RANimp-NBsync  
**UID:** 655  
**Main responsibility:** RAN1

### References for WI " Node B synchronisation for TDD "

Document	Title/Contents
RAN_Work_Items_History	WI Description
<b>Impacted Specifications/ TRs</b>	
TS 25.123	Requirements for Support of Radio Resource Management (TDD)
TS 25.221	Physical channels and mapping of transport channels onto physical channels (TDD)
TS 25.224	Physical Layer Procedures (TDD)
TS 25.225	Physical layer – Measurements (TDD)
TS 25.301	Radio Interface Protocol Architecture
TS 25.302	Services provided by the physical layer
TS 25.303	Interlayer procedures in connected mode
TS 25.321	MAC Protocol Specification
TS 25.331	RRC Protocol Specification
TS 25.402	Synchronisation in UTRAN Stage 2
TS 25.433	UTRAN Iub Interface NBAP Signalling
TS 25.423	UTRAN Iur Interface RNSAP Signalling
<b>New Dedicated Specifications/ TRs</b>	
TR 25.836	Node B synchronisation for TDD
TR 25.838	Node B synchronisation for TDD(Iub/Iur aspects)

Under the Release 4, the Node B synchronisation for TDD was introduced within this Work Item. This provides the functionality to enable Nodes B to be synchronised for UTRA TDD cells by the required modifications within the UTRA layers 1/2/3 for Rel. 99. The cell synchronisation is necessary for UTRA TDD in order to fully exploit the system capacity. This functionality enables the TDD Inter Node B Node Synchronisation via the air interface and also the synchronisation of cells among each other belonging to the same Node B or to neighbouring Node B.

For support of the Node B synchronisation for TDD, the following functionalities are provided:

- Synchronisation of the radio frame clock and multiframe clock between neighbouring cells
- Possibility to synchronise cells without external reference at each Node B
- Possibility to synchronise the TDD cells belonging to the same or to different Node B to an external clock (e.g. GPS) provided at a sync port.

### 6.4.2 Radio Access Bearer Support Enhancements for Rel-4

655	Node B synchronisation for TDD	R1	RANimp-NBsync
2206	RAB support enhancement for Rel-4 below	R2	RANimp-RABSE

**Acronym:** RANimp-RABSE  
**UID:** 2206  
**Main responsibility:** RAN2

### References for WI " Radio Access Bearer Support Enhancements for Rel-4"

Document	Title/Contents
RAN_Work_Items_History	WI Description
<b>Impacted Specifications/ TRs</b>	
TS 25.331 TS 25.323 TR 25.844 Release 4	Radio Resource Control (RRC); Protocol Specification Packet Data Convergence Protocol (PDCP) Specification Radio Access Bearer Bearer Support Enhancements
<b>New Dedicated Specifications</b>	
-	None

Under the Release 4, the RObust Header Compression functionality (ROHC) was introduced within this Work Item. Its benefit is an important reduction in header overhead, simply because the fields of the headers of IP packets are either constant or changing in a known pattern. Hence it is possible to send only information regarding the nature of the changing fields of those headers.

This leads to a reduction in the total size of header + payload, from 60 octets into 20 octets for some applications (e.g. IP based voice applications) and with IP version 4, and from about 80 octets to 20 octets with IP version 6. This translates directly into bandwidth efficiency.

The ROHC scheme is claimed to be more suited to cellular environment and changing links than the previous compression schemes.

The Robust Header compression protocol (RFC 3095) is included as a new functionality of the (already existing) Packet Data Convergence Protocol (PDCP), and this for the Release 4.

One of the use of ROHC is real-time IP services (over wireless links).

## 7 Improvements of GSM-only pre-Release 4 features

### 7.1 Gb over IP (GERAN improvements 1)

**Acronym:** GEIMP1  
**UID:** 2310 and 2311  
**Main responsibility:** GP

**References for WI " GERAN improvements 1 (Gb over IP) "**

Document	Title/Contents
GP-000433	WI Description
GP-000434	Same as above
<b>Impacted Specifications</b>	
TS 48.016	BSS Serving GPRS Support Node (SGSN) interface;
TS 48.018	Network Service Serving GPRS Support Node (SGSN); BSS GPRS Protocol (BSSGP)
<b>New Dedicated Specifications</b>	
	None

The evolution in data communication services leads to increased support for IP-based end-user services. The fixed infrastructure is in place to support the services via IP-based terrestrial networks; IP architecture and protocols support IP multimedia domain users.

In UMTS, the Core Network is based on different transport networks. One of the alternatives is IP based and also the Iu interface between 3G Core Network and Radio Access Networks is IP based.

This Work Item allows the Gb-interface to be configured to include IP based sub-network as an alternative sub-layer to existing Frame Relay sub-network. The IP sub-network will be the common sub-network between 2 / 3 G Core Networks and GSM/EDGE Radio Access Network (GERAN).

The user of the Network Service will experience one common Network Service independent of the utilised sub-network, see figure below.

## Gb interface - IP position

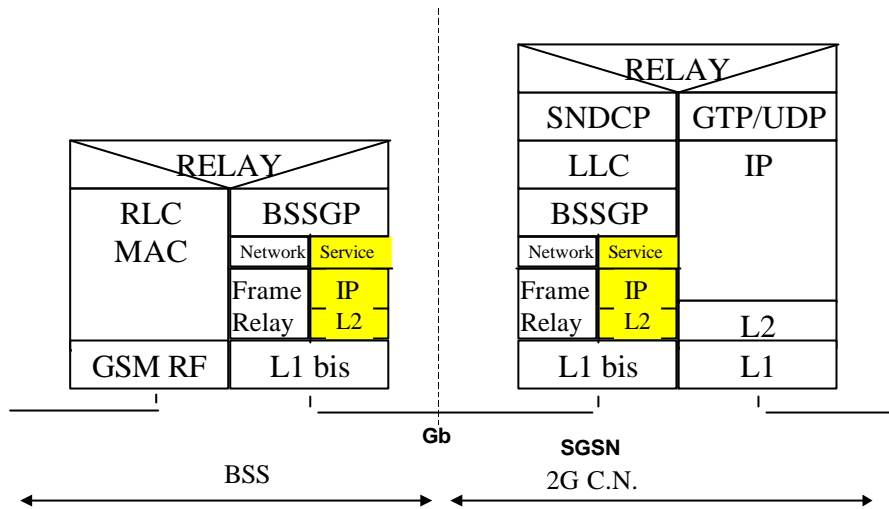

TS 48.016 specifies the Network Service used on the Base Station System (BSS) to Serving GPRS Support Node (SGSN) interface (Gb interface). The Network Service entity provides network services to the BSS GPRS Protocol (BSSGP) entity specified in TS 48.018. The required procedures between BSS and SGSN are defined in detail in TS 48.018.

## 7.2 Network Assisted Cell Change - NACC (GERAN improvements 2)

**Acronym:** GEIMP2  
**UID:** 2314 and 2316  
**Main responsibility:** GP

### References for WI " GERAN improvements 2 (NACC) "

Document	Title/Contents
GP-012812	WI Description on Intra BSC NACC (Network Assisted Cell Change)
<b>Impacted Specifications</b>	
TS 44. 018	Mobile radio interface layer 3 specification; Radio Resource Control Protocol.
TS 44. 060	Mobile Station (MS) - Base Station System (BSS) interface; Radio Link Control/ Medium Access Control (RLC/MAC) protocol.
TS 45. 008	Radio subsystem link control.
	<i>Non exhaustive</i>
<b>New Dedicated Specifications</b>	
	<i>None</i>

The Network Assisted Cell Change consists of two independent procedures:

- one procedure that can assist a mobile station in packet transfer mode with neighbour cell system information required for initial packet access after a cell change;
- one procedure in which the mobile station notifies the network when the cell reselection is determined and delays the cell re-selection to let the network respond with neighbour cell system information.

The purpose of this feature is to shorten the service outage time when the mobile station re-selects between GERAN cells (belonging to the same Base Station Controller, BSC). This improves (as it reduces) the

interruption time (in GPRS data transfer). It is defined as mandatory for a Release 4 mobile station (supporting the General Packer Radio Service, GPRS).

In the original GPRS specifications, under some scenarios defined by some network settings (known as NC0 or NC1), the cell change was performed without notifying the network. For this, the mobile station had to acquire all the necessary information on the new cell, leading to an interruption in the session.

With this feature, the network assists the mobile station before and during the cell change. For this, the mobile informs the network of its wish to change cell. In turn, the network provides the mobile while on the old cell in a dedicated connection all the "System Information" that is needed for accessing the new cell. This is done in a much quicker way than acquiring information broadcast from the new cell and therefore the interruption to the session is considerably reduced. Note that while doing this the network may order the mobile to reselect to another cell than the one initially identified by the mobile.

The Network Assisted Cell Change procedures are part of the *GERAN Feature Package 1* (see also 3GPP TS 24.008)

This NACC functionality is enhanced in the Release 5 of the specifications to assist in the cell reselection between two cells parented by different BSCs (external NACC).

### 7.3 Delayed TBF (GERAN improvements 4)

**Acronym:** GEIMP4  
**UID:** 2324 and 2325  
**Main responsibility:** GP

**References for WI " GERAN improvements 4 (Delayed TBF) "**

Document	Title/Contents
GP-010363	WI Description
<b>Impacted Specifications</b>	
TS 44.060	Mobile Station (MS) - Base Station System (BSS) interface; Radio Link Control/ Medium Access Control (RLC/MAC) protocol.
<b>New Dedicated Specifications</b>	
	None

GPRS RLC/MAC procedures were designed for non real-time data transfer where the data arrives as one large block. However, the true nature of packet traffic is usually different from this assumption. Typically there is a considerable amount of interactive message exchange between client and the server before the actual data transfer may begin and even during the data transfer. For example in the IMAP email protocol (commonly used to access mail server) the client generates a lot of requests to the server and typically the next request is sent only after receiving response for the previous request. This kind of a behaviour, which is common for many applications, leads to a high number of Temporary Block Flow (TBF) establishments and releases. The current procedures for establishment and releases were felt not sufficient; consequently, the resource utilization would be far from optimal, transmission delays unnecessary long and the load on the common control channels increased. This feature solves the problem of frequent TBF establishments and improve (E)GPRS Release 4 performance by:

1. Enhancing the RLC/MAC behavior in case of typical IP applications (e.g. e-mail, HTTP, FTP);
2. Reducing the number of TBF establishments caused by interactive client-server message exchange; this would in turn reduce the delay in signalling and data transfer;
3. Reducing the load on common control channels.

The following Stage 3 changes were included in 44.060:

- Definition of enhanced countdown procedure
- Definition of enhanced TBF release procedure
- Definition of USF=FREE type polling mechanism on PDCH



Note that the mobile station shall support in Release 4 the "extended uplink Temporary Block Flow (TBF)" mode (as part of the *GERAN Feature Package 1*).

In extended uplink TBF mode, the uplink TBF may be maintained during temporary inactive periods, where the mobile station has no Radio Link Control (RLC) information to send. The network determines the release of the uplink TBF.

## 8 Other aspects

### 8.1 Rel-4 Charging and OAM&P

**Acronym:** OAM  
**UID:** 401142  
**Main responsibility:** SA5

#### References for WI "Rel-4 Charging and OAM&P"

Document	Title/Contents
SP-000524	SA5 proposed Work-Plan & Work Items for Release 4 It contains the following WIDs:
S5-000569	WID for Feature: UTRAN Operations and Maintenance procedures (UOAM)
S5-000570	WID for Feature: Charging and OAM&P (OAM)
S5-000571	WID for BB: Principles, high level Requirements and Architecture (OAM-AR)
S5-000572	WID for BB: Configuration Management (OAM-CM)
S5-000573	WID for BB: Fault Management (OAM-FM)
S5-000574	WID for BB: Performance Management (OAM-PM)
S5-000575	WID for BB: Charging Management (OAM-CH)
<b>Impacted Specifications</b>	
32.101	Telecommunication management; Principles and high level requirements
32.102	Telecommunication management; Architecture
<b>On Telecommunication management; Fault Management:</b>	
32.111-1	Part 1: 3G fault management requirements
32.111-2	Part 2: Alarm Integration Reference Point (IRP): Information Service
32.111-3	Part 3: Alarm IRP: CORBA Solution Set
32.111-4	Part 4: Alarm IRP: CMIP Solution Set
<b>New Dedicated Specifications</b>	
<b>On Telecommunication management; Charging management</b>	
32.200	Charging principles
32.205	Charging data description for the Circuit Switched (CS) domain
32.215	Charging data description for the Packet Switched (PS) domain
32.235	Charging data description for application services
<b>On Telecommunication management; Configuration Management (CM);</b>	
32.300	Name convention for Managed Objects
	Notification IRP series:
32.301	Requirements
32.302	Information Service
32.303	CORBA Solution Set
32.304	CMIP Solution Set
	Generic IRP management series:
32.311	Requirements
32.312	Information Service
<b>On Telecommunication management; Performance Management (PM);</b>	
32.401	Concept and requirements
32.402	Performance measurements - GSM
32.403	Performance measurements - UMTS and combined UMTS/GSM
<b>On Telecommunication management; Configuration Management (CM);</b>	
32.600	Concept and high-level requirements
	Basic CM IRP series:
32.601	Requirements
32.602	Information Service
32.603	CORBA Solution Set
32.604	CMIP Solution Set
	Bulk CM IRP series:
32.611	Requirements
32.612	Information Service
32.613	CORBA Solution Set
32.614	CMIP Solution Set
32.615	XML file format definition
	Generic network resources IRP series:
32.621	Requirements
32.622	Information Service
32.623	CORBA Solution Set
32.624	CMIP Solution Set
	Core network resources IRP series:
32.631	Requirements

32.632	Network Resource Model (NRM)
32.633	CORBA Solution Set
32.634	CMIP Solution Set
	UTRAN network resources IRP series:
32.641	Requirements
32.642	Network Resource Model (NRM)
32.643	CORBA Solution Set
32.644	CMIP Solution Set
	GERAN network resources IRP series:
32.651	Requirements
32.652	Network Resource Model (NRM)
32.653	CORBA Solution Set
32.654	CMIP Solution Set
	<b>Others</b>
32.800	Management level procedures and interaction with UTRAN

The objective of Release 4 Charging and OAM&P (Operation, Administration, Maintenance and Provisioning, also called OAM) is to continue progressing the framework to be followed by all 3GPP TSGs and WGs dealing with 3G Systems' Telecom Management (e.g. SA5, RAN O&M, GERAN O&M, etc.).

OAM and Charging both provide interfaces, with appropriate functions, to operators' Operational Support Systems (OSS) and back-office systems for the purpose of planning, provisioning and monitoring of services, subscribers and network entities as well as charging and billing.

The figure below shows the relationship between the OSS and the monitored components, which are the elements of the "3GPP Network": the terminals (T), the Radio Access Network (RAN), the GSM EDGE RAN (GERAN) and the Core Network (CN). The aim of this feature is to have OAM&P and Charging interfaces as common as possible.

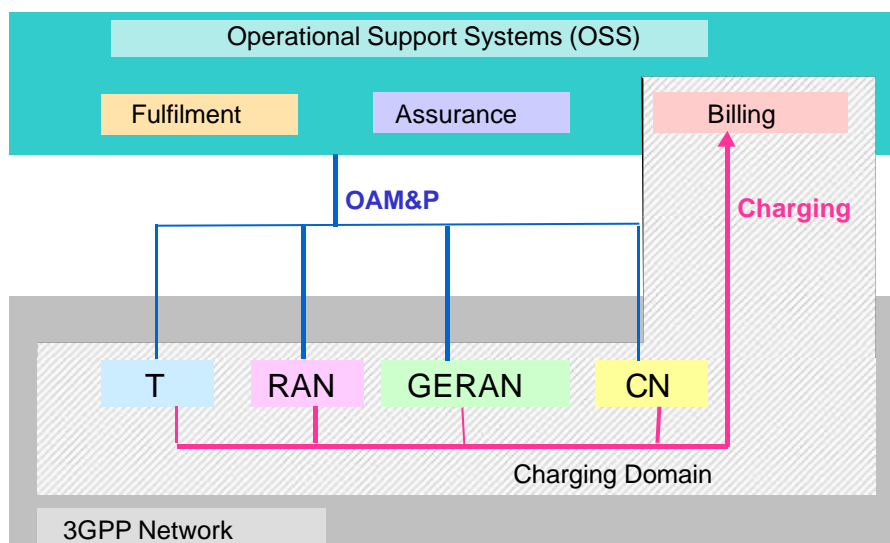

Overview of OAM and Charging: Domain and Flows

## 8.2 Miscellaneous UE Conformance Testing Activities

**Acronym:** MISTST1  
**UID:** 1861  
**Main responsibility:** T1

The testing of the Release 4 feature is just started by now. A description will be added to this document when the work will progress. The structure of the testing documents is described in the document "Description of the Release 99".

## 8.3 Small Technical Enhancements and Improvements for Rel4

**Acronym:** TEI4  
**UID:** 1993  
**Main responsibility:** Generic

This Feature is just a “joker” to be used for change requests bringing a minor modification to the system, with limited impact. It consists for example of the following changes:

- Changes to TS 23.038:
  - Automatic removal of ‘read’ SMS
  - Data coding scheme value for the Icelandic language
  - Message Waiting Indication Status storage on the USIM
- Changes to TS 23.040:
  - Addition of numbering plan value for Service Centre Specific Addresses
  - SMS Address fields enhancements
  - User prompt indication
  - Predefined animations for EMS
- and many other small changes.

## 8.4 Facsimile group 3, non transparent

**Acronym:** FAX-RT  
**UID:** 1340  
**Main responsibility:** N3

**References for WI " Facsimile group 3, non transparent "**

Document	Title/Contents
NP-99140	WI Description
<b>Impacted Specifications</b>	
TS 22.003	Circuit Teleservices supported by a Public Land Mobile Network (PLMN)
<b>New Dedicated Specifications</b>	
TS 23.146	Technical realization of facsimile group 3 non-transparent

The fixed network facsimile group 3 service is an international telematic service for document transmission between two facsimile group 3 terminals.

The service specifications are comprised of two parts:

- the control procedures described in ITU-T Recommendation T.30;
- the document transmission coding described in ITU-T Recommendation T.4.

The UMTS facsimile group 3 Teleservice allows connections between facsimile group 3 terminals using:

- a UMTS PLMN as stand-alone facility for mobile -to-mobile communication;
- a UMTS PLMN to have access to fixed networks PSTN and/or ISDN for mobile to/from fixed network communication.

For this Teleservice, the coding of the facsimile document is as per ITU-T Recommendation T.4 and the protocol as per ITU-T Recommendation T.30 both modified within the PLMN as detailed in the present document.

The interworking between different networks is based on ITU-T Recommendation X.300.

The particular features of this Teleservice are:

- it uses point-to-point communication;
- the information transfer mode is circuit, duplex, asynchronous;
- the information transfer capability is alternate speech/ facsimile group 3 or facsimile group 3 only;
- both mobile originated and mobile terminated calls are supported;
- different end-to-end message speeds as per ITU-T Recommendation T.30 may be used within the same connection to match the appropriate quality requirements;
- use of the standard asynchronous terminal adaptation function for non-transparent network support (as per 3GPP TS 27.002) within the UE is envisaged.

## 8.5 “Hollow” features

These features were once defined by 3GPP, but no work was actually done.

### 8.5.1 Operator Determined Barring for Packet Oriented Services

**Acronym:** ODB  
**UID:** 2463  
**Main responsibility:** NP

WI Description in NP-010089, but no work was done on this feature.

### 8.5.2 Rel-4 Security enhancements

It appeared *a posteriori* that nothing was done in Release 4 concerning Security enhancements. All the WIDs which once belonged to Release 4 are then “hollow”. All the corresponding structure given below did not lead to any concrete impact on the specifications in this Release.

**Acronym:** SEC1  
**UID:** 401571  
**Main responsibility:** SA3

#### References for WI " Rel-4 Security enhancements "

Document	Title/Contents
SP-000421	WI Description containing: S3-000488: UE triggered authentication during connections S3-000490: Enhanced home control of security by HE S3-000599: USIM toolkit security S3-000609: Location services security S3-000610: VHE security S3-000611: Study on network-based denial of services attacks
<b>Impacted Specifications</b>	
TS 33.102 TS 22.022 TS 33.107	Security architecture Personalisation of ME LI architecture
<b>New Dedicated Specifications</b>	
TS 21.133 TS 33.200 TR 33.909	Threats and requirements MAP Application Layer Security An Example Algorithm for the 3GPP Authentication and Key Generation Functions

#### Contains:

UID	Title	WG	Acronym	WID	Comment
1587	Evolution of GSM CS algorithms (e.g. A5/3 development and deployment)	S3	SEC1-CSALGO1	SP-000306	Algorithm development go-ahead at SA3#21. Scheduled for completion in August 2002?. Approved SA#17. DELETE ENTRY FROM REL-4?
1588	Evolution of GSM PS algorithms (e.g. GEA 2 deployment)	S3	SEC1-PSALGO1	SP-000307	A5/3 development will consider new GEA algorithm based on Kasumi.
401583	MAP application layer security	S3	SEC1-MAPAL		"TO DELETE: REPLACED BY NDS-MAP and NDS-IP. TO BE DELETED, but replacement NDS-MAP was missing. Completed Auto Key Management -> Rel-6"

### 8.5.3 Global Text Telephony

This Release-independent Feature is described in the document “Description of the Release 5”.

