

3G TR 25.877 V2.0.0 (2002-02)

Technical Report

3rd Generation Partnership Project; Technical Specification Group Radio Access Network; High Speed Downlink Packet Access: Iub/Iur protocol aspects

(Release 5)



The present document has been developed within the 3rd Generation Partnership Project (3GPP™) and may be further elaborated for the purposes of 3GPP.

The present document has not been subject to any approval process by the 3GPP Organisational Partners and shall not be implemented. This Specification is provided for future development work within 3GPP only. The Organisational Partners accept no liability for any use of this Specification. Specifications and reports for implementation of the 3GPP™ system should be obtained via the 3GPP Organisational Partners' Publications Offices.

Keywords

UMTS, HSDPA

3GPP

Postal address

3GPP support office address

650 Route des Lucioles - Sophia Antipolis
Valbonne - FRANCE
Tel.: +33 4 92 94 42 00 Fax: +33 4 93 65 47 16

Internet

<http://www.3gpp.org>

Copyright Notification

No part may be reproduced except as authorized by written permission.
The copyright and the foregoing restriction extend to reproduction in all media.

© 2001, 3GPP Organizational Partners (ARIB, CWTS, ETSI, T1, TTA, TTC).
All rights reserved.

Contents

Foreword.....	6
1 Scope.....	7
2 References.....	7
3 Definitions, symbols and abbreviations.....	7
3.1 Definitions.....	7
3.2 Symbols.....	7
3.3 Abbreviations.....	7
4 Background and Introduction.....	8
5 Requirements.....	8
6 Study Areas.....	8
6.2 Impacts on Iub Interface - General Aspects.....	8
6.2 Impacts on Iub/Iur Control Plane Protocols.....	10
6.2.1 HSDPA Signalling Requirements (Comparison between DSCH and HS-DSCH).....	10
6.2.2 Impacts on NBAP Procedures.....	12
6.2.2.1 Impacts on Dedicated NBAP Procedures and Message Contents.....	13
6.2.2.1.1 DSCH-related IEs in RNSAP.....	14
6.2.2.1.2 Proposed HS-DSCH-related IEs for NBAP for Downlink Signalling.....	15
6.2.2.1.2.1 Option 1 - One Transport Bearer per HS-DSCH MAC-d Flow.....	15
6.2.2.1.2.2 Option 2 - One Transport Bearer for Multiple HS-DSCH MAC-d Flows for Multiple UE's.....	18
6.2.2.1.3 Proposed HS-DSCH-related IEs for NBAP for Uplink Signalling.....	20
6.2.2.2 Impacts on Dedicated RNSAP Procedures and Message Contents.....	20
6.2.2.3 NBAP cell-level configuration handling.....	20
6.2.2.3.1 FDD 20	
6.2.2.3.1.1 Impact on NBAP Procedures.....	20
6.2.2.3.1.2 Proposed cell based HS-DSCH IEs.....	20
6.2.2.3.2 TDD 22	
6.2.2.3.2.1 Physical Shared Channel Reconfiguration [TDD] procedure.....	22
6.2.3 Example of HS-DSCH Configuration and Capacity Allocation.....	23
6.2.4 Examples of HS-DSCH Mobility Procedures.....	26
6.2.4.1 Intra-Node B serving HS-DSCH cell change.....	26
6.2.4.2 Inter-Node B serving HS-DSCH cell change.....	28
6.2.4.3 Inter-Node B serving HS-DSCH cell change at hard handover.....	29
6.2.4.4 Inter-Node B serving HS-DSCH cell change after radio link addition.....	33
6.2.5 Open Issues.....	35
6.3 Impacts on Iub Interface User Plane Protocols.....	35
6.3.1 Transport Bearer Options.....	35
6.3.1.1.1 Frame Protocol Aspects for HS-DSCH.....	36
6.3.1.1.2 Data Frame Format for HS-DSCH Frame Protocol.....	36
6.3.1.1.3 Control Frame Format for HS-DSCH Frame Protocol.....	38
6.3.1.1.4 Open Issues.....	39
6.3.1.2 Option 2 - One Transport Bearer for Multiple MAC-d flows for Multiple UE's.....	39
6.3.1.2.1 Frame Protocol Aspects for HS-DSCH.....	39
6.3.1.2.2 Data Frame Format for HS-DSCH Frame Protocol.....	40
6.3.1.2.2.1 Coding of information elements in data frames.....	42
6.3.1.2.3 Control Frame Format for HS-DSCH Frame Protocol.....	43
6.3.1.2.4 Open Issues.....	43
6.3.1.3 Inter-operability of Options 1 and 2.....	43
6.3.1.3.1 Signalling Flow Cases.....	44
6.3.1.3.1.1 CRNC allows HSDPA data stream multiplexing and Node B decides to multiplex (Case 1).....	44
6.3.1.3.1.2 CRNC allows HSDPA data stream multiplexing and Node B decides not to multiplex (Case 2).....	45
6.3.2 Flow Control Options.....	46
6.3.2.1 Option 1 - Credit Based Flow Control.....	46

6.3.2.1.1	HS-DSCH Data Transfer.....	46
6.3.2.1.2	HS-DSCH Capacity Request.....	47
6.3.2.1.3	HS-DSCH Capacity Allocation.....	47
6.4	QoS Aspects	48
6.5	TDD versus FDD Aspects	48
6.6	Backwards Compatibility	48
7	Agreements and associated contributions.....	48
8	Specification Impact and associated Change Requests.....	48
	History.....	50

Foreword

This Technical Report has been produced by the 3rd Generation Partnership Project (3GPP).

The contents of the present document are subject to continuing work within the TSG and may change following formal TSG approval. Should the TSG modify the contents of the present document, it will be re-released by the TSG with an identifying change of release date and an increase in version number as follows:

Version x.y.z

where:

- x the first digit:
 - 1 presented to TSG for information;
 - 2 presented to TSG for approval;
 - 3 or greater indicates TSG approved document under change control.
- y the second digit is incremented for all changes of substance, i.e. technical enhancements, corrections, updates, etc.
- z the third digit is incremented when editorial only changes have been incorporated in the document.

1 Scope

This document is part of the Release 5 work item “High Speed Downlink Packet Access (HSDPA) Iub/Iur protocol aspects”. The purpose of the present document is to help the TSG RAN WG3 group to specify the changes to existing Iub/Iur specifications, needed for the introduction of the “High Speed Downlink Packet Access” feature for Release 5. This work task belongs to the TSG RAN Building Block “High Speed Downlink Packet Access (HSDPA)”.

2 References

The following documents contain provisions which, through reference in this text, constitute provisions of the present document.

- References are either specific (identified by date of publication, edition number, version number, etc.) or non-specific.
- For a specific reference, subsequent revisions do not apply.
- For a non-specific reference, the latest version applies.

- [1] RP-010262, Work Item Description: High Speed Downlink Packet Access (HSDPA)
- [2] 3GPP TR 25.855 v5.0.0 High Speed Downlink Packet Access: Overall UTRAN Description
- [3] 3GPP TS 25.308 v.5.1.0: UTRA High Speed Downlink Packet Access (HSDPA); Overall description.

3 Definitions, symbols and abbreviations

3.1 Definitions

For the purposes of the present document, the following terms and definitions apply.

Example: text used to clarify abstract rules by applying them literally.

3.2 Symbols

3.3 Abbreviations

For the purposes of the present document, the following abbreviations apply:

CFN	Connection Frame Number
CP	Control Plane
DCH	Dedicated Channel
FP	Frame Protocol
HI	HS-DSCH Indicator
HSDPA	High Speed Downlink Packet Access
HS-DPCCH	High Speed Dedicated Physical Control Channel
HS-DSCH	High Speed Downlink Shared Channel
HS-PDSCH	High Speed Physical Downlink Shared Channel
HS-SCCH	High Speed Shared Control Channel
HS-SICH	HSDPA Shared Information Channel

MAC-hs	Medium Access Control-High Speed
RL	Radio Link
SID	Size Index
TB	Transport Block
TFRI	Transport Format and Resource Indicator
UP	User Plane

4 Background and Introduction

In RAN#11 plenary meeting a work item[1] was approved for High Speed Downlink Packet Access. The work item includes techniques such as adaptive modulation and coding, hybrid ARQ and fast scheduling with the goal to increase throughput, reduce delay and achieve high peak rates.

5 Requirements

In addition to the overall system requirements outlined and agreed upon in Section 5 of [2], the following specific requirements to RAN3 should be applied:

1. Alignments between the TDD mode and the FDD mode HSDPA solution are desirable. Although, these should not take precedence if it leads to major performance degradations in one mode.

6 Study Areas

6.2 Impacts on Iub Interface - General Aspects

The protocol architecture of HSDPA is described in [3]. From the Fig. 1 and from the figures describing MAC architecture it is obvious that general aspects and principles of Iub interface should be updated accordingly. One new MAC functional entity, the MAC-hs, is added to the R99 architecture. The MAC-hs is located in the Node B. If one or more HS-DSCHs are in operation the MAC-hs SDUs to be transmitted are transferred from MAC-d via MAC-c/sh to the MAC-hs via the Iub interface. The transport channel that the HSDPA functionality will use is called HS-DSCH. The transport channel is controlled by MAC-hs. The HS-DSCH FP will handle the data transport from SRNC to CRNC (if the Iur interface is involved) and between CRNC and the Node B.

Items to be added/modified to Iub interface for preparing Node B logical model for HS-DSCH are (sections according to TS 25.430):

4.4 Iub Interface Capabilities:

4.4.x Iub HS-DSCH data stream

The Iub interface provides the means for transport of downlink shared channel, HS-DSCH, data frames between RNC and Node B. An Iub HS-DSCH data stream corresponds to the data carried on one MAC-d flow for one UE. A UE may have multiple HS-DSCH data streams.

4.5 Iub Interface Characteristics:

4.5.1 Mapping of Iub data streams

HS-DSCH An Iub HS-DSCH data stream is carried on one transport bearer. For each HS-DSCH data stream, a transport bearer must be established over the Iub interface. Otherwise, multiple Iub HS-DSCH data streams may share one transport bearer.

5.2 Functional split over Iub

5.2.x Traffic management of High Speed Shared Channels

The high speed shared channels shall be controlled from the Node B. This includes the control of the HS-DSCH channels as well as the required control channels on the radio interface.

6 Node B logical Model over Iub

6.1 Overview

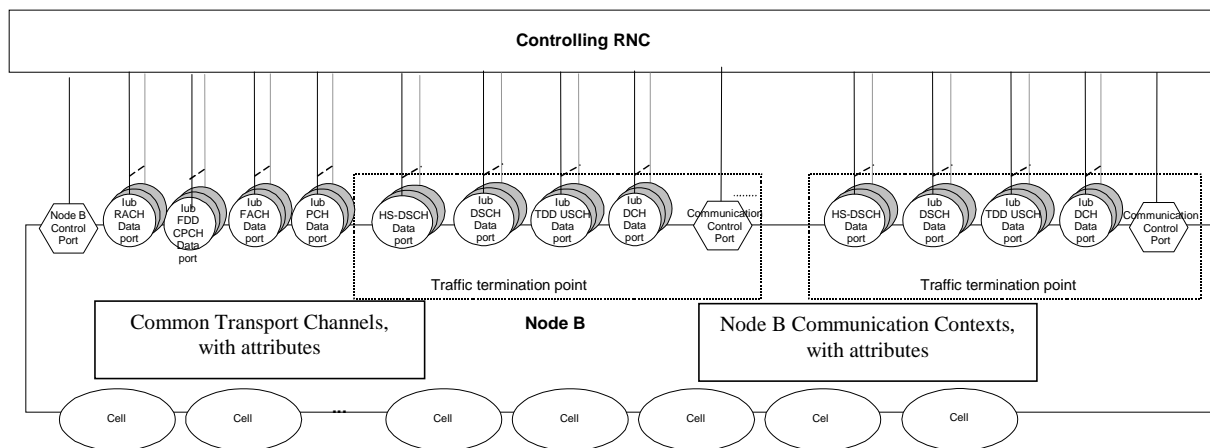

Figure 1: Logical Model of Node B

6.2 Elements of the logical model:

6.2.1 Node B Communication Contexts for Dedicated and Shared Channels

A Node B Communication Context corresponds to all the dedicated resources that are necessary for a user in dedicated mode and using dedicated and/or shared channels as restricted to a given Node B. [TDD - The Node B Communication Context also exists for users in Cell_FACH mode (i.e. non-dedicated mode) provided a USCH and/or DSCH and/or HS-DSCH has been allocated to these users.]

There are a number of Node B Communication Contexts inside a given Node B.

The attributes to a Node B Communication Context shall include the following (not exhaustive):

- The list of Cells where dedicated and/or shared physical resources are used.
- The list of DCH which are mapped on the dedicated physical resources for that Node B Communication Context.
- The list of DSCH and USCH [TDD] which are used by the respective UE.
- The list of HS-DSCH MAC-d flows which are used by the respective UE.
- The complete DCH characteristics for each DCH, identified by its DCH-identifier [4].
- The complete Transport Channel characteristics for each DSCH and USCH, identified by its Shared Channel identifier [4].
- HS-DSCH characteristics for each HS-DSCH, identified by its High Speed Shared Channel identifier.
- The list of Iub DCH Data Ports.
- The list of Iub DSCH Data ports and Iub USCH data ports.
- The list of Iub HS-DSCH Data ports.
- For each Iub DCH Data Port, the corresponding DCH and cells which are carried on this data port.
- For each Iub DSCH and USCH data port, the corresponding DSCH or USCH and cells which serve that DSCH or USCH.

- For each Iub HS-DSCH Data port, the corresponding HS-DSCH data streams and the cell which serves these HS-DSCH data streams.
- Physical layer parameters (outer loop power control, etc).

6.2.x Node B Communication Contexts for HS-DSCH

6.2.3.x Iub HS-DSCH Data Port

An Iub HS-DSCH Data Port represents a UP transport bearer carrying one or more Iub HS-DSCH Data Streams between the Node B and the RNC.

6.2.3.3 Traffic Termination Point represents DCH, DSCH, TDD USCH and HS-DSCH data streams belonging to one or more Node B Communication Contexts, which are controlled via one Communication Control Port. Proposed Logical Model of Node B is according to Fig. 1.

6.2.4 Radio Network Logical Resources:

6.2.4.4 Physical Shared Channels

[FDD - A HS-PDSCH is defined by a channelisation code within a code subtree that is configured within a specific Communication Context. The HS-PDSCH is activated dynamically as part of the HS-DSCH scheduling.]

[TDD - A HS-PDSCH is defined by a channelisation code, a time slot and other Physical Channel parameters. The HS-PDSCH is activated dynamically as part of the HS-DSCH scheduling.]

6.2 Impacts on Iub/Iur Control Plane Protocols

6.2.1 HSDPA Signalling Requirements (Comparison between DSCH and HS-DSCH)

With respect to the majority of R99/Rel4 transport channels, HS-DSCH is different in several aspects. We focus on the following:

1. the HS-DSCH Transport Block Set consists of one Transport Block only;
2. one Transport Block corresponds to several MAC-d PDUs (i.e. MAC-hs SDUs);
3. there is only one HS-DSCH per UE;

According to point 1), the Transport Format Set definition is very simplified in that it is entirely determined by the Transport Block size. Point 3) obviates the need for any Transport Format Combinations.

HS-DSCH makes use of explicit out-of-band signalling carried on the HS-SCCH channels. The following out-of-band signalling information is carried on a per-TTI basis:

- codes (a set of up to 15 codes chosen in a contiguous manner from the global HSDPA code set);
- modulation (either QPSK or 16-QAM);
- Transport Format (defining a Transport Block size from a set of configured Transport Block sizes).

In addition, the size of the MAC-d PDUs belonging to a Transport Block is carried in every MAC-hs header. Hence, almost all information required for signal decoding is *explicitly* signalled, which is a departure from the DSCH paradigm where a lot of configuration is needed (e.g. TB size, TB set size, codes). The only parameter related to Transport Formats that remains to be configured for HS-DSCH is the allowed set of Transport Block sizes.

The following table summarise the main differences between DSCH and HS-DSCH from a configuration viewpoint.

	DSCH	HS-DSCH

Static part (CP configured)	<ul style="list-style-type: none"> ➤ TTI; ➤ Channel coding type; ➤ Coding rate; ➤ Rate matching attribute; ➤ CRC size 	<p>1) Parameters related to transport formats:</p> <ul style="list-style-type: none"> ➤ table of MAC-d PDU SIDs; ➤ table of allowed TB sizes (will be used on HS-SCCH); <p>2) Parameters related to UE capabilities:</p> <ul style="list-style-type: none"> ➤ max number of HS-PDSCH codes; ➤ max bits per HS-DSCH TTI; ➤ min inter-TTI interval; <p>3) HARQ process info</p>
Static part (not configured via CP)	N/A	<ul style="list-style-type: none"> ➤ TTI = 2ms; ➤ Channel coding = turbo; ➤ Coding rate = 1/3; ➤ Rate matching = FFS; ➤ CRC size = 24bits; ➤ Spreading factor = 16
Dynamic part (UP)	<p>TF Combinations consisting of:</p> <ul style="list-style-type: none"> ➤ TB size; ➤ TB Set size; ➤ codes 	<p>There are no TFCs.</p> <p>Transport Format info consists of:</p> <ul style="list-style-type: none"> ➤ one or several MACd PDU SIDs and the number of PDUs with these sizes (in MAC-hs PDU header) ➤ Transport Format indicating the TB size (on HS-SCCH)
TB and TB Set meaning	<p>1 TB = 1 MAC-c/sh SDU + Header (UE-id)</p> <p>1 TB Set = N * TB</p>	<p>1 TB = N * MAC-d PDU + Header (TSN, Priority)</p> <p>1 TB Set = 1 TB</p>
Spreading Factor	variable	fixed = 16
TFCI or TFRI meaning	<p>TFCI identifies a TFC i.e.:</p> <ul style="list-style-type: none"> ➤ codes; ➤ TB size; ➤ TB Set size; 	<p>Explicitly signalled via TFRI:</p> <ul style="list-style-type: none"> ➤ codes; ➤ modulation; <p>Implicitly signalled:</p> <ul style="list-style-type: none"> ➤ TB size (via Transport Format). ➤ MAC-d PDU size (via MAC-hs PDU header).
UE identifier	added by CRNC in the MAC-c/sh header; transparent to Node B	used by Node B for a UE-specific CRC in HS-SCCH and/or HS-DSCH

Note: Current working assumption is that the same scrambling code is used for HS-PDSCH, HS-SCCH. The DPCH may use the same or a different scrambling code .

It is obvious that HS-DSCH needs less configuration related to Transport Formats and channel coding for two reasons:

1. Many HS-DSCH parameters are already fixed (e.g. TTI, Coding type, coding rate, CRC size, Spreading factor), and
2. A lot of HS-DSCH information is explicitly or implicitly signalled via HS-SCCH (e.g. codes, modulation, Transport Block size, MAC-hs SDU size).

On the other hand, HS-DSCH needs some additional static configuration information related to UE HSDPA capabilities (including HARQ process configuration), which has no equivalent in DSCH.

Also shown in the table are some important semantic innovations with HSDPA:

- A single HS-DSCH Transport Block may consist of several MAC-hs SDUs, and
- The MAC-hs header carries new types of information (HARQ process ID, Priority, Padding indicator) instead of/along with a UE-id.

6.2.2 Impacts on NBAP Procedures

For supporting HSDPA, the radio link (which shall carry the HS-DSCH) has to be set up or reconfigured.

Examples of parameters that are necessary for HSDPA are the following:

- information about the HI that should be included in the DPCH,
- configuration of the HS-SCCH,
- configuration of HS-DSCH,
- etc.

The following procedures of NBAP have to be changed in order to initiate the HS-DSCH configuration and capacity allocation:

Radio Link Setup (FDD and TDD)

To support HSDPA, one or more HS-DSCHs have to be set up in addition to the DCH. The CRNC sends a RADIO LINK SETUP REQUEST to the Node B, containing the necessary parameters for HS-DSCH configuration (HS-DSCH id, transport format set, etc.).

The message RADIO LINK SETUP RESPONSE should provide information about HS-DSCHs that have been established or modified.

Synchronised Radio Link Reconfiguration (FDD and TDD)

The DPCH has to be changed to include the HI. It is suggested that the preparation of the DPCH can be performed by including an *HI presence* IE in the message RADIO LINK RECONFIGURATION PREPARE.

The message RADIO LINK RECONFIGURATION PREPARE has to also include the information that allows the Node B the addition, modification or deletion of HS-DSCHs. If a HS-DSCH is added or modified, the parameters concerning HS-DSCH configuration have to be sent to the Node B (HS-DSCH id, transport format set, etc.).

The message RADIO LINK RECONFIGURATION READY should provide information about HS-DSCHs that have been established or modified.

Common Transport Channel Setup (FDD and TDD)

A HS-SCCH has to be set up for carrying the HS-DSCH related information. Therefore, the information of the HS-SCCH should be included in the message COMMON TRANSPORT CHANNEL SETUP REQUEST.

The message COMMON TRANSPORT CHANNEL SETUP RESPONSE shall contain the “*Shared Control Channel Parameters*” that inform the CRNC about the new configured channels.

Physical Shared Channel Reconfiguration (TDD)

The information about the set of HS-PDSCHs which the Node B should use for scheduling is sent in the message PHYSICAL SHARED CHANNEL RECONFIGURATION REQUEST from CRNC to Node B. An IE-group “HS-PDSCH to add Information” resp. “HS-PDSCH to modify Information” has to be added (FFS).

6.2.2.1 Impacts on Dedicated NBAP Procedures and Message Contents

In this discussion we focus on the dedicated NBAP procedures related to HS-DSCH channel addition/deletion:

- Radio Link Setup, and
- Radio Link Reconfiguration.

The following four NBAP messages are involved in these two procedures:

1. RADIO LINK SETUP REQUEST;
2. RADIO LINK RECONFIGURATION PREPARE;
3. RADIO LINK SETUP RESPONSE, and
4. RADIO LINK RECONFIGURATION READY.

Signalling means is needed in NBAP for:

- configuring HS-DSCH transport and physical channels, and
- providing information on codes allocated to HS-SCCH.

Our intent is to use messages 1) and 2) for configuring HS-DSCH channels at the Node B. The relevant information would be carried in a new *HS-DSCH Information* IE, in the way it is done today with its DSCH equivalent.

Messages 3) and 4) would be used by Node B to inform the RNC about the codes allocated by Node B for the HS-SCCH channels. The relevant information would be carried in a new *HS-DSCH Information Response* IE, in the way it is done today with its DSCH equivalent.

Note that we use RNSAP IEs as a starting point for the definition of new NBAP IEs. This is explained by the fact that the Node B with HSDPA performs several functions (e.g. code allocation, scheduling) similar to those performed by CRNC/DRNC with DSCH. The data units carried on Iub are now *MAC SDU flows* rather than Transport Block flows, which is again similar to the DSCH case over Iur.

6.2.2.1.1 DSCH-related IEs in RNSAP

- DSCH FDD Information IE in RNSAP**

The *DSCH FDD Information* IE provides information for DSCHs to be established.

IE/Group Name	Presence	Range	IE type and reference	Semantics description	Criticality	Assigned Criticality
DSCH Specific FDD Information		1..<maxno ofDSCHs>			–	
>DSCH ID	M		9.2.1.26A		–	
>TrCh Source Statistics Descriptor	M		9.2.1.65		–	
>Transport Format Set	M		9.2.1.64	For DSCH	–	
>Allocation/Retention Priority	M		9.2.1.1		–	
>Scheduling Priority Indicator	M		9.2.1.51A		–	
>BLER	M		9.2.1.4		–	
PDSCH RL ID	M		RL ID 9.2.1.49		–	
TFCS	M		9.2.1.63	For DSCH	–	
>Enhanced DSCH PC	O		9.2.2.13D		YES	ignore

Range bound	Explanation
MaxnoofDSCHs	Maximum number of DSCHs for one UE.

- DSCH FDD Information Response IE in RNSAP**

The *DSCH FDD Information Response* IE provides information for DSCHs that have been established or modified.

IE/Group Name	Presence	Range	IE type and reference	Semantics description	Criticality	Assigned Criticality
DSCH Specific FDD Information Response		1..<Maxno ofDSCHs>			–	
>DSCH ID	M		9.2.1.26A		–	
>DSCH Flow Control Information	M		9.2.1.26B		–	
>Binding ID	O		9.2.1.3		–	
>Transport Layer Address	O		9.2.1.62		–	
PDSCH Code Mapping	M		9.2.2.27A	PDSCH code mapping to be used	–	

Range bound	Explanation
MaxnoofDSCHs	Maximum number of DSCHs for one UE.

6.2.2.1.2 Proposed HS-DSCH-related IEs for NBAP for Downlink Signalling

6.2.2.1.2.1 Option 1 - One Transport Bearer per HS-DSCH MAC-d Flow

It is assumed that HS-DSCH MAC-d flows are carried over Iub interface in the same way as DSCH MAC-c/sh SDU flows are in R99/Rel4 i.e. every MAC-d flow is carried on a separate transport bearer. This assumption has an impact on the details of the IE contents.

- **Proposed *HS-DSCH Information* IE for NBAP**

The *HS-DSCH Information* IE provides information for HS-DSCH to be established. It may be included in the RADIO LINK SETUP REQUEST or RADIO LINK RECONFIGURATION PREPARE messages.

IE/Group Name	Presence	Range	IE type and reference	Semantics description	Criticality	Assigned Criticality
HS-DSCH RNTI ⁽¹⁾	M		INTEGER (0..15)			
HS-DSCH MAC-d Flow Specific FDD Information		1..<Maxno ofMACdFlows>			–	
>HS-DSCH MAC-d Flow ID ⁽²⁾	M		INTEGER (0..MaxnofPriorityQueues – 1)		–	
					–	
>BLER	M		INTEGER (-63..0)	Step 0.1. (Range – 6.3...0). It is the Log10 of the BLER	–	
>Allocation/Retention Priority	M		9.2.1.1A		–	
>Priority Queue Information	M	1..<Maxno ofPriorityQueues>				
>>Priority Queue ID ⁽³⁾	M		INTEGER (0..MaxnofPriorityQueues – 1)			
>>Traffic Class (FFS)	O		ENUMERATED(conversational, streaming, interactive, background)		–	
>>Scheduling Priority Indicator	O		INTEGER (0..15)	Relative priority of the HS-DSCH data frame: 0=Lowest Priority ... 15=Highest Priority	–	
>>MAC-d PDU Size Index ⁽⁴⁾	O	1..<Maxno ofMACdPDUindexes>				
>>>SID	O		INTEGER (0..MaxNoOfMACdPDUs)	(FFS)		
>>>MAC-d PDU Size	O		(FFS)			
>HS-DSCH Dynamic Transport Format Information⁽¹⁾		1..<Maxno ofHSDSCHTFcount>			–	
>>HS-DSCH Transport Block Set Size	M		INTEGER (0..FFS)			
HS-PDSCH RL ID	M		RL ID 9.2.1.53	FDD only	–	
UE Capabilities information						
>Max TrCh Bits per HS-	M		INTEGER			

IE/Group Name	Presence	Range	IE type and reference	Semantics description	Criticality	Assigned Criticality
DSCH TTI ⁽⁷⁾			(FFS)			
>HS-PDSCH multi-code capability ⁽⁷⁾	M		INTEGER (1..MaxnoofHSPDSC Hcodes)			
>Min Inter-TTI Interval ⁽⁷⁾	M		FFS			
>MAC-hs reordering buffer size	M		INTEGER (FFS)			
HARQ Information					–	
>Number of processes	M		INTEGER (1..MaxnoofHARQprocesses)			
>Memory partitioning	M	1..<MaxnoofHARQprocess>				
>>Process memory size	M		INTEGER (FFS)			

Range bound	Explanation
MaxnoofMACdFlows	Maximum number of HS-DSCH MAC-d flows
MaxnoofPriorityQueues	Maximum number of Priority Queues
MaxnoofHSDSCHTFcount	Maximum number of HS-DSCH TF count
MaxnoofHARQprocesses	Maximum number of HARQ processes for one UE.
MaxnoofHSPDSC Hcodes	Maximum number of HS-PDSCH codes
MaxnoofMACdPDUindexes	Maximum number of different MAC-d PDU SIDs

Notes:

1. HS-DSCH RNTI is needed for the UE-specific CRC in HS-SCCH and/or HS-DSCH.;
2. the number of MAC-d flows is lower or equal to the number of Priority Queues;
3. it is assumed that each Priority Queue has a unique Priority Queue ID allocated by SRNC and distributed to Node B via NBAP/RNSAP procedures (NOTE: this detail is to be considered within RAN3; it is not in the scope of RAN2); the mapping between the 16 RAB priorities and the Priority Queue IDs is FFS;
4. MAC-d PDU sizes and their mapping to SIDs is determined by SRNC. Node B can impose a restriction on the maximum permitted MAC-d PDU size;
5. void;
6. there is no notion for TFCS, since there may be only one HS-DSCH per UE;
7. in order to avoid duplicate efforts, the parameters related to UE capabilities could be defined by pointing to the equivalent RRC definitions;
8. the following RNSAP IEs (in red) should be added to NBAP: *RAB attributes (FFS)*, *Scheduling Priority Indicator* and *BLER*.
9. void.

- **Proposed HS-DSCH Information Response IE for NBAP**

The *HS-DSCH Information Response* IE provides information for HS-DSCH that have been established or modified. It may be included in the RADIO LINK SETUP RESPONSE and RADIO LINK RECONFIGURATION READY messages.

IE/Group Name	Presence	Range	IE type and reference	Semantics description	Criticality	Assigned Criticality
Measurement feedback reporting cycle k1	M		INTEGER(0, 1, 5, 10, 20, 40, 80)	employed by the UE when not in soft handover	–	
Measurement feedback reporting cycle k2	M		INTEGER(0, 1, 5, 10, 20, 40, 80)	employed by the UE when in soft handover	–	
HS-DSCH MAC-d Flow Specific FDD Information Response		<i>1..<MaxnofMACdFlows></i>			–	
>HS-DSCH MAC-d Flow ID	M		INTEGER(0..<MaxnofPriorityQueues - 1)		–	
>Binding ID	O		9.2.1.4		–	
>Transport Layer Address	O		9.2.1.63		–	
>HS-DSCH Flow Control Information	M	<i>1..<MaxnofPriorityQueues></i>				
>>Priority Queue ID	M		INTEGER(0..<MaxnofPriorityQueues - 1)			
>>MAC-d PDU Lengths		<i>1..<MaxnofMACdPDUIlengths></i>				
>>maximum MAC-d PDU Length	M		INTEGER(FFS)			
HS-SCCH Specific Information Response⁽²⁾		<i>1..<MaxnofHSSCCHsets></i>				
>List of HS-SCCH sets ⁽³⁾	M		(FFS)			
>HS-SCCH set	M		(FFS)			

Range bound	Explanation
<i>MaxnofMACdFlows</i>	Maximum number of HS-DSCH MAC-d flows.
<i>MaxnofPriorityQueues</i>	Maximum number of Priority Queues
<i>MaxnofMACdPDUIlengths</i>	Maximum number of different MAC-d PDU lengths
<i>MaxnofHSSCCHsets</i>	Maximum number of HS-SCCH sets.

Notes:

1. void;
2. PDSCH Code Mapping is replaced by HS-SCCH sets information.
3. *List of HS-SCCH sets* IE is needed only for the alternative where the Node B is allowed to re-allocate Serving HS-SCCH sets to UEs without involving RRC and/or NBAP/RNSAP procedures..
4. For TDD, information related to the HS-SICH should also be provided by the Node B
5. RL IDs of Radio Link over which HI is transmitted are listed except for HS-PDSCH RL ID.

6.2.2.1.2.2 Option 2 - One Transport Bearer for Multiple HS-DSCH MAC-d Flows for Multiple UE's

RNC decides whether it wants to allow HSDPA Iub Mux or not. If RNC decides to allow Mux, it chooses candidate transport bearer to be shared and includes them in the *Transport Bearer id List* IE in *HS-DSCH MAC-d Flow Specific FDD Information* IE. If Node B receives any Transport Bearer ids in

the *Transport Bearer id List* IE then it considers RNC allows HSDPA Iub Mux option and chooses one transport bearer in the list. Even though Node B receives more than one of Transport Bearer ids in the *Transport Bearer id List* IE but it decides not to share a transport bearer then Node B provides a new transport bearer information (TNL address and Binding id). If Node B doesn't receives *Transport Bearer id List* IE, then it assumes that RNC doesn't allow HSDPA Iub Mux and provides a new transport bearer information (TNL address and Binding id).

- **Proposed *HS-DSCH Information IE* for NBAP**

It is proposed to add 1 additional IE in *HS-DSCH MAC-d Flow Specific Information* IE for Option 2 (in addition to the already proposed additions under Option 1).

IE/Group Name	Presence	Range	IE type and reference	Semantics description	Criticality	Assigned Criticality
HS-DSCH MAC-d Flow Specific FDD Information						
...						
>Transport Bearer id List		0.. <i>MaxnoofTr Bearerid</i>				
>>Transport Bearer id	M		INTEGER			
...						

Range bound	Explanation
<i>MaxnoofTrBearerid</i>	Maximum number of HS-DSCH Transport bearers which can be shared

Note: For TDD, the same *Transport Bearer id List* IE shall be included in the *HS-DSCH MAC-d Flow Specific TDD Information* IE for NBAP.

- **Proposed *HS-DSCH Information Response IE* for NBAP**

It is proposed to add 1 additional IE in *HS-DSCH Information Response* IE.

IE/Group Name	Presence	Range	IE type and reference	Semantics description	Criticality	Assigned Criticality
HS-DSCH MAC-d Flow Specific FDD Information Response						
...						
>Transport Bearer Id	M		INTEGER			
...						

- Transport Bearer Id

The *Transport Bearer Id* IE is the identifier of the transport bearer for HS-DSCH data stream. It is unique among the transport bearers for HS-DSCHs over Iub at a certain time.

IE/Group Name	Presence	Range	IE type and reference	Semantics description
Transport Bearer Id			INTEGER	

Note: For TDD, the same *Transport Bearer Id* IE shall be included in the *HS-DSCH TDD Information Response* IE for NBAP.

6.2.2.1.3 Proposed HS-DSCH-related IEs for NBAP for Uplink Signalling

Information for HS-DPCCH (Status Indicator(ACK/NACK) and Channel Quality Indicator): current working assumption is that this channel does not need to be configured via NBAP/RNSAP procedures.

6.2.2.2 Impacts on Dedicated RNSAP Procedures and Message Contents

The information elements proposed above for NBAP could be used for RNSAP as they are.

6.2.2.3 NBAP cell-level configuration handling

6.2.2.3.1 FDD

6.2.2.3.1.1 Impact on NBAP Procedures

To configure the cell-based parameters, 3 possibilities can be considered in NBAP.

- Adding new parameters in Cell Setup/Cell Reconfiguration procedure
- Adding new parameters in Common Transport Channel Setup/Common Transport Channel Reconfiguration procedure
- Defining new procedures

During the initial phase, there is no big difference which procedure will be used since the Cell Setup procedure and the Common Transport Channel Setup procedure are use at about same time. But reconfiguring the HS-DSCH cell based parameters should be considered rather carefully because this new function should not affect R99/REL-4 implementation too much.

The parameters in CELL RECONFIGURATION REQUEST message and COMMON TRANSPORT CHANNEL RECONFIGURATION REQUEST message are very static and can be considered as O&M parameters. On the other hand, HS-DSCH cell based parameters should be configured based on cell but they don't need to be that static.(i.e. like the parameters in CELL RECONFIGURATION REQUEST message or COMMON TRANSPORT CHANNEL RECONFIGURATION message). Since for many reasons, (for example, load sharing,..) the RNC may need to reconfigure the cell based HS-DSCH IEs rather frequently, and we have to try to avoid affecting existing implementations too much, it is proposed to define a new procedure for delivering cell based HS-DSCH parameters.

6.2.2.3.1.2 Proposed cell based HS-DSCH IEs

The following parameters can be considered as cell specific and should be configured for the HSDPA resource pool.

IE/Group Name	Presence	Range	IE type and Reference	Semantics description	Criticality	Assigned Criticality
HSDPA Information		0..1			YES	reject
>HS_PDSCH + HS-SCCH Total Power	O		FFS			
> DL Scrambling Code for HS_PDSCH and HS-	M		INTEGER (0..15)	Scrambling code on		

SCCH				which PDSCH is transmitted. 0= Primary scrambling code of the cell 1...15 = Secondary scrambling code		
>Code Information for HS_DSCH						
>Code Information for HS_SCCH						

- HS_PDSCH + HS-SCCH Total Power

The HS_PDSCH + HS-SCCH Total Power defines the total power for all HS-PDSCHs and all HS-SCCHs. Details are FFS.

IE/Group Name	Presence	Range	IE type and reference	Semantics description
HS_PDSCH + HS-SCCH Total Power		FFS		

- Code Information for HS_DSCH

The Code Information for HS_DSCH defines the number of codes, which will be assigned for HS-DSCH.

Information Element/Group name	Presence	Range	IE type and reference	Semantics description
Start Code Number	M		Integer(0..maxCodeNum Comp-1)	HS-DSCH code start.
Stop Code Number	M		Integer(0..maxCodeNum Comp-1)	HS-DSCH code stop

- Code Information for HS_SCCH

The Code Information for HS_SCCH defines the codes, which will be assigned for HS-SCCH. The Node B will assign codes for HS-SCCHs among these codes when it sets up a HS-DSCH.

Information Element/Group name	Presence	Range	IE type and reference	Semantics description
Choice <i>Signalling Method</i>				
>Code Range				
>> Start Code Number	M		Integer(0..maxCodeNum Comp-1)	HS-DSCH code start.
>> Stop Code Number	M		Integer(0..maxCodeNum Comp-1)	HS-DSCH code stop
>Explicit				
>>HS_SCCH Code		1..<MaxnoofH SSCCHs >		
>>>Code Number	M		Integer(0..maxCodeNum Comp-1)	

Range bound	Explanation
MaxnoofHSSCCHs	Maximum number of HS-SCCHs for one cell. The value for MaxnoofHSSCCHs is FFS.

6.2.2.3.2 TDD

6.2.2.3.2.1 Physical Shared Channel Reconfiguration [TDD] procedure

This information of the set of HS-PDSCHs that the Node B should use for scheduling is sent through PHYSICAL SHARED CHANNEL RECONFIGURATION REQUEST [TDD] message.

HS-PDSCH Sets to add		0..1 ⁽¹⁾			GLOBAL	Reject
>DL Timeslot Information		0 .. <maxnoofDLts>		For 3.84Mcps TDD only	–	
>>Time Slot	M		9.2.3.23		–	
>>Midamble Shift and Burst Type	M		9.2.3.7		–	
>>DL Code Information		1 .. <maxnoOfHS-PDSCH>			–	
>>>HS-PDSCH ID	M		XX		–	
>>>TDD Channelisation Code	M		9.2.3.19		–	

HS-PDSCH Set to Modify		0..1			GLOBAL	Reject
>DL Timeslot Information		0 .. <maxnoofDLts>		For 3.84Mcps TDD only	–	
>>Time Slot	M		9.2.3.23		–	
>>Midamble Shift and Burst Type	O		9.2.3.7		–	
>>DL Code Information		0 .. <maxnoOfHS-PDSCH>			–	
>>>HS-PDSCH ID	M		XX		–	
>>>TDD Channelisation Code	O		9.2.3.19		–	

Range bound	Explanation
<i>Maxnoof HS-PDSCH</i>	Maximum number of HS-DSCH in a cell for 3.84Mcps TDD only.
<i>MaxnoofDLts</i>	Maximum number of Downlink time slots in a cell for 3.84Mcps TDD.

- HS-PDSCH ID

The HS-PDSCH ID identifies unambiguously a HS-PDSCH inside a cell.

IE/Group Name	Presence	Range	IE type and reference	Semantics description
HS-PDSCH ID			INTEGER (0..255)	

This information of the physical resource of HS-SCCHs (DL) and HS-SICHs (UL) is sent through COMMON TRANSPORT CHANNEL SETUP REQUEST and COMMON TRANSPORT CHANNEL RECONFIGURATION REQUEST messages.

>>HS-SCCH Physical Channel Parameters		<i>0..<MaxnoofHS-SCCHs></i>			GLOBAL	Reject
>>>Common Physical Channel ID	M		9.2.1.13		–	
>>>TDD Channelisation Code	M		9.2.3.19		–	
>>>Time Slot	M		9.2.3.23		–	
>>>Midamble shift and Burst Type	M		9.2.3.7		–	
>>>HS-SCCH Power	M		DL Power 9.2.1.21		–	
>>> HS-SICH Physical Channel Parameters	M	<i>1</i>			YES	Reject
>>>>Time Slot	M		9.2.3.23		–	
>>>>TDD Channelisation Code	M		9.2.3.19		–	
>>>> Midamble shift and Burst Type	FFS		9.2.3.6		–	

Range bound	Explanation
<i>MaxnooHS-SCCHs</i>	Maximum number of HS-SCCH in a cell for 3.84Mcps TDD.

6.2.3 Example of HS-DSCH Configuration and Capacity Allocation

The following picture is an example sequence chart explaining the setup of HS-DSCH. It is assumed that the UE is in cell_DCH state. In case no RL has already been established, the Radio Link Setup procedure is used instead of the Radio Link Reconfiguration procedure.

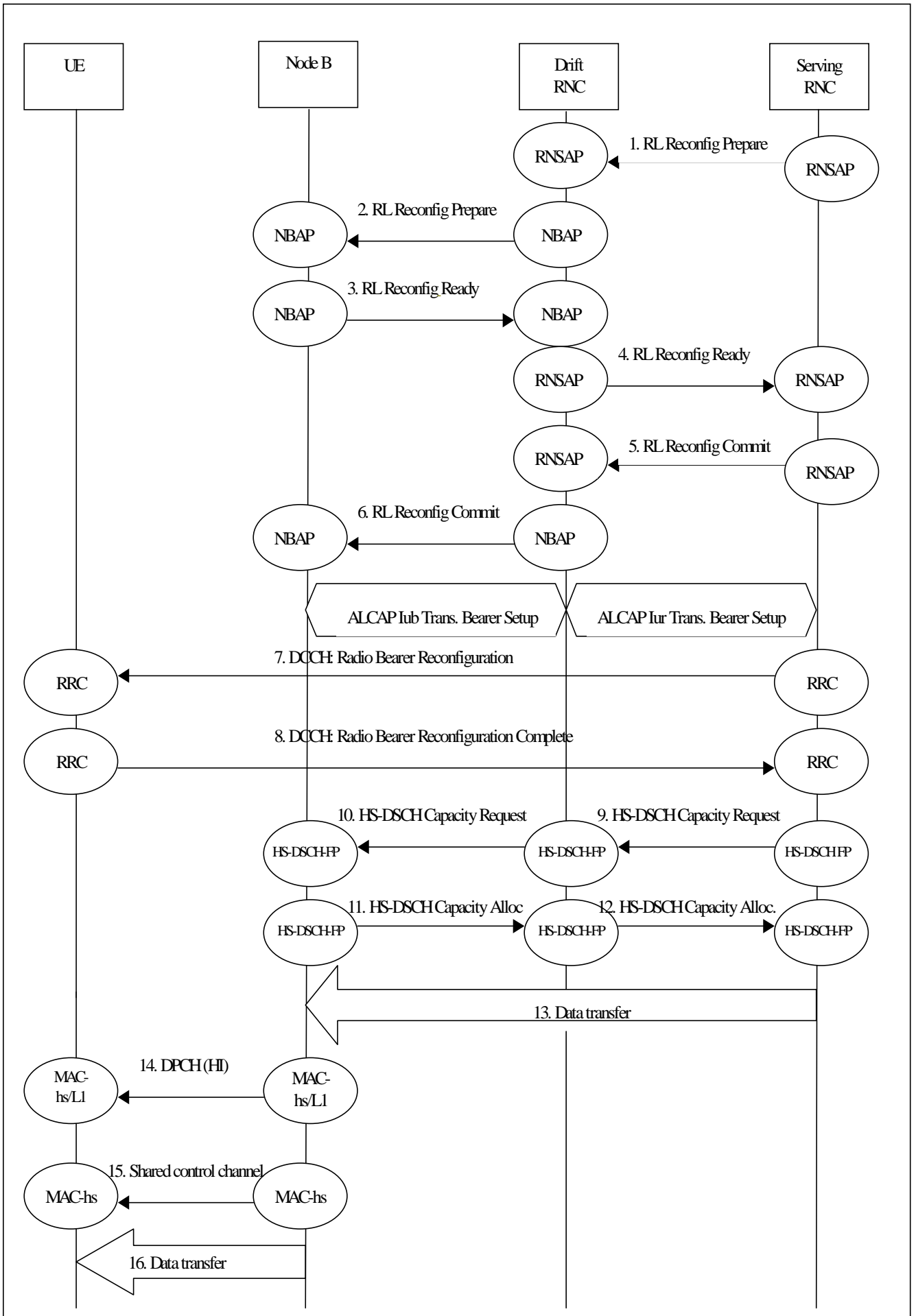

1. For supporting HSDPA, the radio link which shall carry the HS-DSCH has to be reconfigured. The SRNC initiates a Radio Link Reconfiguration by sending RADIO LINK RECONFIGURATION PREPARE message to DRNC.
2. The DRNC requests the respective Node B to prepare the synchronised RL reconfiguration by sending the NBAP RADIO LINK RECONFIGURATION PREPARE message.
3. Node B configures resources for the HS-DSCH and responds with NBAP RADIO LINK RECONFIGURATION READY message.
4. When the DRNC has completed the preparation phase, RADIO LINK RECONFIGURATION READY message is sent to the SRNC.
5. RNSAP RADIO LINK RECONFIGURATION COMMIT message is sent from SRNC to DRNC.
6. NBAP RADIO LINK RECONFIGURATION COMMIT message is sent from DRNC to Node B.
7. The SRNC sends a RADIO BEARER RECONFIGURATION message to the UE to establish the requested HS-DSCH.
8. The UE replies with a RADIO BEARER RECONFIGURATION COMPLETE message. - At this point in time, the HS-DSCH Transport Channel has been set up, and it is assumed that the MAC-hs in the Node B has already been configured earlier to have access to a pool of HS-PDSCH resources for HS-DSCH scheduling.
9. As soon as the SRNC detects the necessity to send HS-DL data on one HS-DSCH, it sends a HS-DSCH CAPACITY REQUEST control frame within the HS-DSCH Frame Protocol to the CRNC.
10. The CRNC forwards this message (HS-DSCH CAPACITY REQUEST control frame) to the Node B. So in this example sequence, the CRNC does not interfere with the HS-DSCH scheduling.
11. The Node B determines the amount of data (credits) that can be transmitted on the HS-DSCH and reports this information back to the DRNC in a HS-DSCH CAPACITY ALLOCATION control frame in the HS-DSCH Frame Protocol.
12. The DRNC sends the HS-DSCH CAPACITY ALLOCATION control frame to SRNC. So again, the DRNC does not react itself to that message in this example.
13. The SRNC starts sending DL data to the Node B. (This is done via the two HS-DSCH Frame Protocol "hops" on Iur and Iub interface.)
The Node B schedules the DL transmission of DL data on HS-DSCH which includes allocation of PDSCH resources.
14. The Node B transmits the HI on the DPCH to the respective UE.
15. The Node B transmits the signalling information (HS-PDSCH coordinates) to the UE using the HS-SCCH.
16. The Node B sends the HS-DSCH data to the UE on the HS-PDSCH(s).

6.2.4 Examples of HS-DSCH Mobility Procedures

NOTE: All signalling flows in this section assume that the non multiplexing of flows for different UE's on one transport bearer is used (Option 1 - One Transport Bearer per HS-DSCH Transport Channel)

6.2.4.1 Intra-Node B serving HS-DSCH cell change

An example of an intra-Node B serving HS-DSCH cell change while keeping the active set is shown in the figure below.

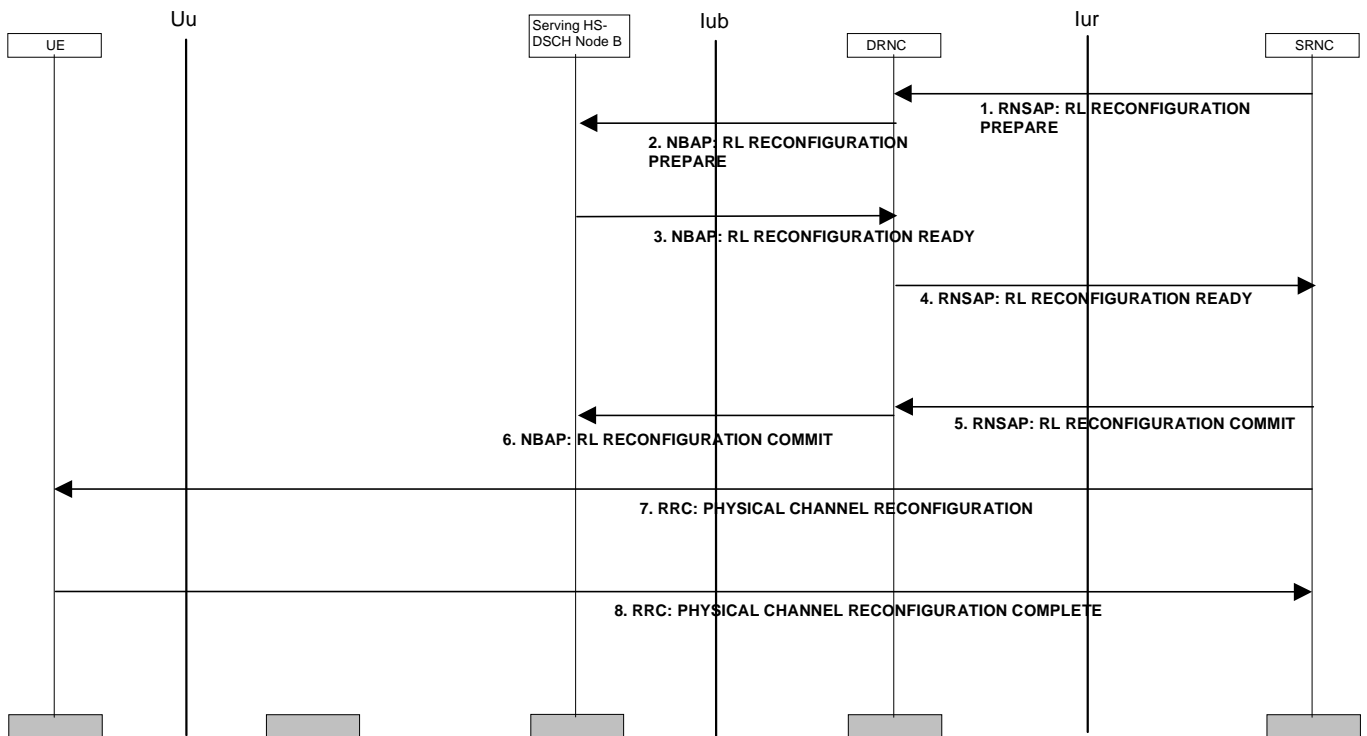

Figure 2: Intra-Node B serving HS-DSCH cell change

1. The SRNC decides there is a need for a serving HS-DSCH cell change and prepares a RADIO LINK RECONFIGURATION PREPARE message which is transmitted to the DRNC. The message includes an identification of the target HS-DSCH cell.
2. In this case, both the source and target HS-DSCH cells are controlled by the same Node B. The DRNC requests the serving HS-DSCH Node B to perform a synchronised radio link reconfiguration using the RADIO LINK RECONFIGURATION PREPARE message. The reconfiguration comprises a transfer of the HS-DSCH resources from the source HS-DSCH radio link to the target HS-DSCH radio link. The message includes also necessary information to setup the HS-DSCH resources in the target HS-DSCH cell, including a DRNC selected HS-DSCH UE identity.
3. The serving HS-DSCH Node B returns a RADIO LINK RECONFIGURATION READY message.
4. The DRNC returns a RADIO LINK RECONFIGURATION READY message to the SRNC. The message includes HS-SCCH set info, scrambling code for the target HS-DSCH cell and the HS-DSCH UE identity.
5. The SRNC now proceeds by transmitting RADIO LINK RECONFIGURATION COMMIT message to the DRNC including an SRNC selected activation time in form of a CFN.
6. The DRNC transmits a RADIO LINK RECONFIGURATION COMMIT message to the serving HS-DSCH Node B including the activation time. At the indicated activation time the serving HS-DSCH Node B stops HS-DSCH transmission to the UE in the source HS-DSCH cell and starts HS-DSCH transmission to the UE in the target HS-DSCH cell.
7. The SRNC transmits a PHYSICAL CHANNEL RECONFIGURATION message to the UE. The message includes activation time, MAC-hs reset indicator, serving HS-DSCH radio link indicator, HS-SCCH set info and HS-DSCH UE identity.
8. At the indicated activation time the UE resets MAC-hs, stops receiving HS-DSCH in the source HS-DSCH cell and starts HS-DSCH reception in the target HS-DSCH cell. The UE returns a PHYSICAL CHANNEL RECONFIGURATION COMPLETE message to the SRNC.

6.2.4.2 Inter-Node B serving HS-DSCH cell change

An example of an inter-Node B serving HS-DSCH cell change while keeping the active set is shown in the figure below.

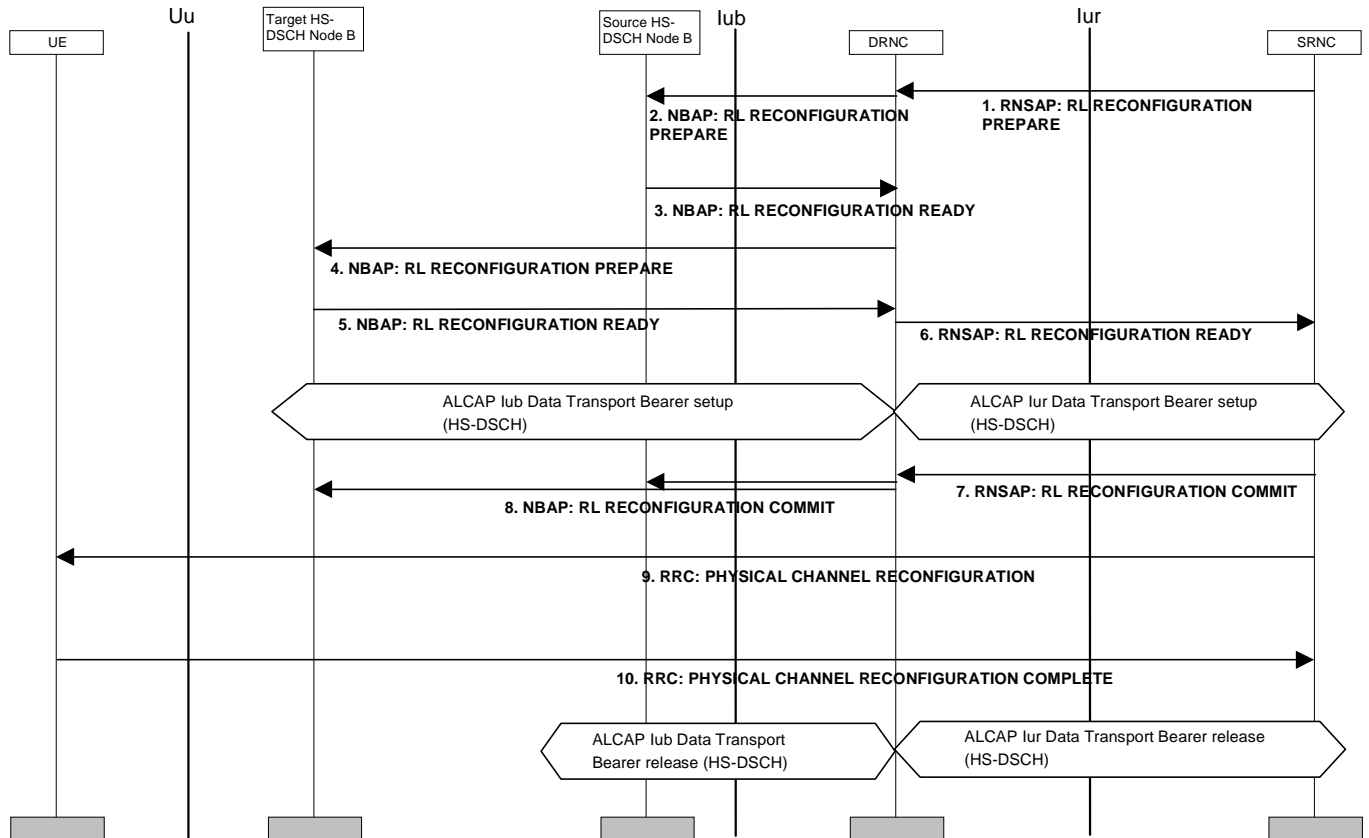

Figure 3: Inter-Node B serving HS-DSCH cell change

1. The SRNC decides there is a need for a serving HS-DSCH cell change and prepares a RADIO LINK RECONFIGURATION PREPARE message which is transmitted to the DRNC. The message indicates the target HS-DSCH cell.
2. In this case, the source and target HS-DSCH cells are controlled by different Node Bs. The DRNC requests the source HS-DSCH Node B to perform a synchronised radio link reconfiguration using the RADIO LINK RECONFIGURATION PREPARE message, removing its HS-DSCH resources for the source HS-DSCH radio link.
3. The source HS-DSCH Node B returns a RADIO LINK RECONFIGURATION READY message including an indicator that MAC-hs will reset as a result of the reconfiguration.
4. The DRNC requests the target HS-DSCH Node B to perform a synchronised radio link reconfiguration using the RADIO LINK RECONFIGURATION PREPARE message, adding HS-DSCH resources for the target HS-DSCH radio link. The message includes also necessary information to setup the HS-DSCH resources in the target HS-DSCH cell, including a DRNC selected HS-DSCH UE identity.
5. The target HS-DSCH Node B returns a RADIO LINK RECONFIGURATION READY message
6. The DRNC returns a RADIO LINK RECONFIGURATION READY message to the SRNC. The message includes HS-SCCH set info, scrambling code for the target HS-DSCH cell and the HS-DSCH UE identity.

7. The HS-DSCH transport bearer to the target HS-DSCH Node B is established. The SRNC proceeds by transmitting RADIO LINK RECONFIGURATION COMMIT to the DRNC including an SRNC selected activation time in form of a CFN.
8. The DRNC transmits a RADIO LINK RECONFIGURATION COMMIT message to the source HS-DSCH Node B and the target HS-DSCH Node B including the activation time. At the indicated activation time the source HS-DSCH Node B stops and the target HS-DSCH Node B starts transmitting on the HS-DSCH to the UE.
9. The SRNC also transmits a PHYSICAL CHANNEL RECONFIGURATION message to the UE. The message includes activation time, MAC-hs reset indicator, serving HS-DSCH radio link indicator, HS-SCCH set info and HS-DSCH UE identity.
10. At the indicated activation time the UE resets MAC-hs, stops receiving HS-DSCH in the source HS-DSCH cell and starts HS-DSCH reception in the target HS-DSCH cell. The UE returns a PHYSICAL CHANNEL RECONFIGURATION COMPLETE message to the SRNC. The HS-DSCH transport bearer to the source HS-DSCH Node B is then released.

6.2.4.3 Inter-Node B serving HS-DSCH cell change at hard handover

Two examples of hard handover combined with an inter-Node B serving HS-DSCH cell change are shown in the figures below.

In the first example the source Node B and the target Node B are controlled by the same DRNC. The HS-DSCH mobility procedure is performed in two steps: the first step consists of establishing a new radio link without the HS-DSCH resources; the next step is a transfer of the HS-DSCH resources to this new radio link followed by a release of the old radio link. In the radio interface, a combined procedure is used.

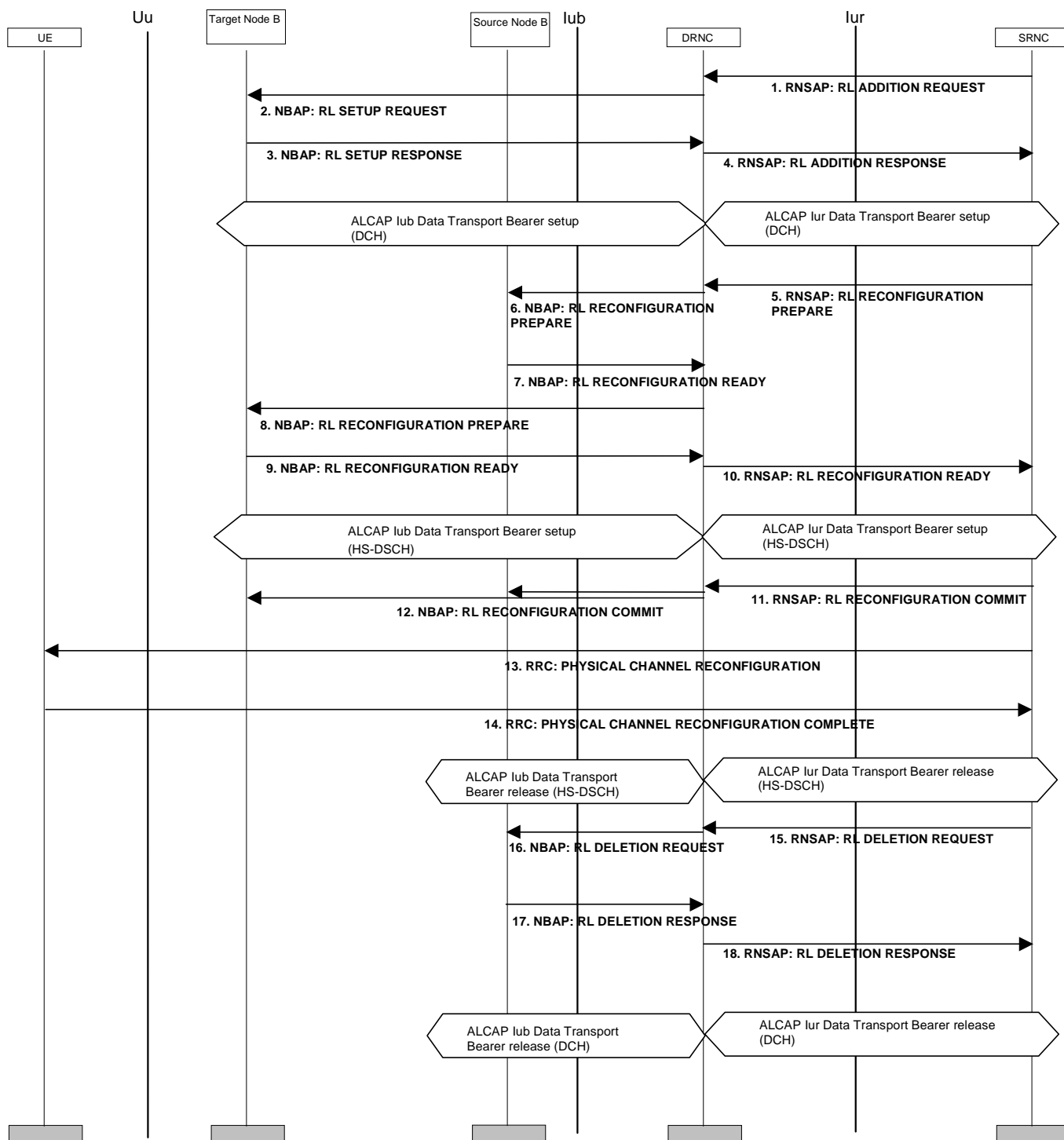

Figure 4a: Inter-Node B serving HS-DSCH cell change during hard handover (two step approach)

1. The SRNC decides that there is a need for a hard handover combined with a serving HS-DSCH cell change. It prepares a RADIO LINK ADDITION REQUEST message, which is transmitted to the DRNC. The message indicates the target cell for hard handover.
2. The DRNC allocates radio resources for the new radio link and requests the target Node B to establish a new radio link by transmitting a RADIO LINK SETUP REQUEST message including the necessary parameters for DPCH establishment.

3. The target Node B allocates resources, starts physical layer reception on the DPCH on the new radio link and responds with RADIO LINK SETUP RESPONSE message.
4. The DRNC responds to the SRNC with RADIO LINK ADDITION RESPONSE message and the DCH transport bearer is established.
5. As the next step, the SRNC prepares a RADIO LINK RECONFIGURATION PREPARE message which is transmitted to the DRNC. The message indicates the target HS-DSCH cell.
6. The DRNC requests the source HS-DSCH Node B to perform a synchronised radio link reconfiguration using the RADIO LINK RECONFIGURATION REQUEST message, removing its HS-DSCH resources for the source HS-DSCH radio link.
7. The source HS-DSCH Node B returns a RADIO LINK RECONFIGURATION READY message.
8. The DRNC requests the target HS-DSCH Node B to perform a synchronised radio link reconfiguration using the RADIO LINK RECONFIGURATION REQUEST message, adding HS-DSCH resources for the target HS-DSCH radio link. The message includes also necessary information to setup the HS-DSCH resources in the target HS-DSCH cell, including a DRNC selected HS-DSCH UE identity.
9. The target HS-DSCH Node B returns a RADIO LINK RECONFIGURATION READY message.
10. The DRNC returns a RADIO LINK RECONFIGURATION READY message to the SRNC. The message includes HS-SCCH set info, scrambling code for the target HS-DSCH cell and the HS-DSCH UE identity.
11. The HS-DSCH transport bearer to the target HS-DSCH Node B is established. The SRNC proceeds by transmitting RADIO LINK RECONFIGURATION COMMIT message to the DRNC including an SRNC selected activation time in form of a CFN.
12. The DRNC transmits a RADIO LINK RECONFIGURATION COMMIT message to the source HS-DSCH Node B and the target HS-DSCH Node B including the activation time. At the indicated activation time the source HS-DSCH Node B stops and the target HS-DSCH Node B starts transmitting on the HS-DSCH to the UE.
13. The SRNC also transmits a PHYSICAL CHANNEL RECONFIGURATION message to the UE. The message includes activation time, DPCH information for the target cell, MAC-hs reset indicator, serving HS-DSCH radio link indicator, HS-SCCH set info and HS-DSCH UE identity.
14. At the indicated activation time the UE abandons the current active set, initiates establishment of the DPCH in the target cell and resets MAC-hs. When physical layer synchronisation is established in the target cell, it starts DPCH reception and transmission and HS-DSCH reception in the target cell. The UE returns a PHYSICAL CHANNEL RECONFIGURATION COMPLETE message to the SRNC. The HS-DSCH transport bearer to the source HS-DSCH Node B is released.
15. The SRNC then finalises the procedure by transmitting a RADIO LINK DELETION REQUEST message to the DRNC. In the message the source cell to be deleted is identified.
16. The DRNC transmits a RADIO LINK DELETION REQUEST message to the source Node B.
17. The source Node B releases resources for the source radio link and returns a RADIO LINK DELETION RESPONSE message to the DRNC.
18. The DRNC returns a RADIO LINK DELETION RESPONSE message to the SRNC. The DCH transport bearer to the source Node B is released.

In the second example the source Node B and the target Node B are controlled by two different DRNCs, referred to as source DRNC and target DRNC, respectively. The HS-DSCH mobility procedure is performed in a single step.

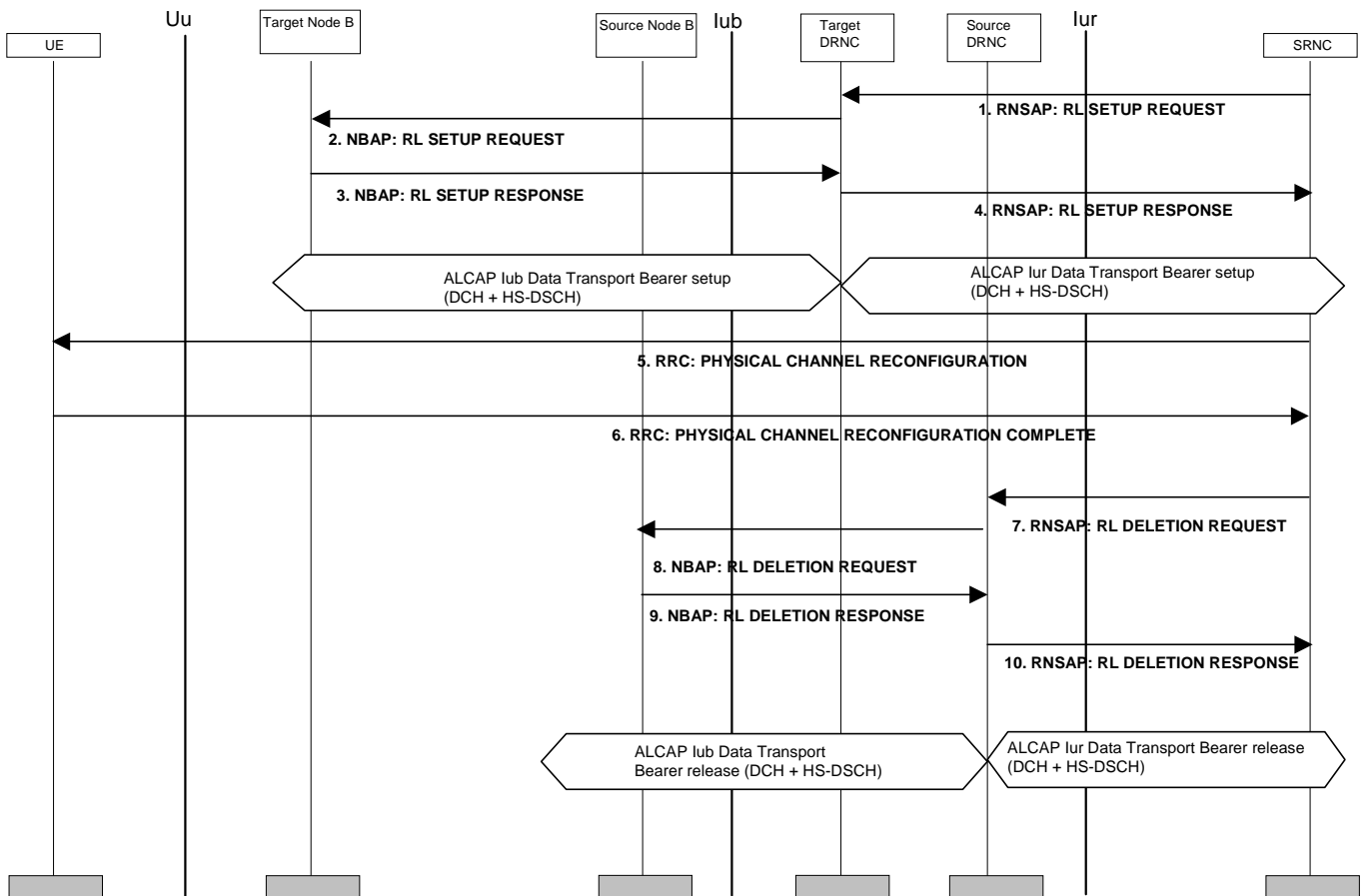

Figure 5b: Inter-Node B serving HS-DSCH cell change during hard handover (single-step approach)

1. The SRNC decides that there is a need for hard handover combined with serving HS-DSCH cell change. It prepares a RADIO LINK SETUP REQUEST message, which is transmitted to the target DRNC. The message indicates the target cell for hard handover along with some information for setup of HS-DSCH resources in the target HS-DSCH cell.
2. The target DRNC allocates radio resources for the new radio link and requests the target Node B to establish a new radio link by transmitting a RADIO LINK SETUP REQUEST. The message includes the necessary parameters for DPCH establishment, as well as information for setup of HS-DSCH resources.
3. The target Node B allocates resources, starts physical layer reception on the DPCH on the new radio link and responds with RADIO LINK SETUP RESPONSE message. The message includes HS-SCCH set info and HS-DSCH flow control info.
4. The target DRNC responds to the SRNC with RADIO LINK SETUP RESPONSE message. The message includes HS-SCCH set info, HS-DSCH flow control info and the HS-DSCH UE identity. DCH and HS-DSCH transport bearers are established on both Iub and Iur.
5. The SRNC transmits a PHYSICAL CHANNEL RECONFIGURATION message to the UE. The message includes activation time, DPCH information for the target cell, MAC-hs reset indicator, serving HS-DSCH radio link indicator, HS-SCCH set info and HS-DSCH UE identity.
6. At the indicated activation time the UE abandons the current active set, initiates establishment of the DPCH in the target cell and resets MAC-hs. When physical layer synchronisation is established in the target cell, it starts DPCH reception and transmission and HS-DSCH reception in the target cell. The UE returns a PHYSICAL CHANNEL RECONFIGURATION COMPLETE message to the SRNC.

7. The SRNC then finalises the procedure by transmitting a RADIO LINK DELETION REQUEST message to the source DRNC. In the message the source cell to be deleted is identified.
8. The source DRNC transmits a RADIO LINK DELETION REQUEST message to the source Node B.
9. The source Node B releases resources for the source radio link and returns a RADIO LINK DELETION RESPONSE message to the source DRNC.
10. The source DRNC returns a RADIO LINK DELETION RESPONSE message to the SRNC. The DCH and HS-DSCH transport bearers to the source Node B are released.

6.2.4.4 Inter-Node B serving HS-DSCH cell change after radio link addition

An example of addition of a radio link becoming the serving HS-DSCH radio link is shown in the figure below. This procedure is performed using two steps, both within the network and towards the UE. In the first step, the new radio link is added to the active set. The HS-DSCH is transferred to the added radio link as a second step.

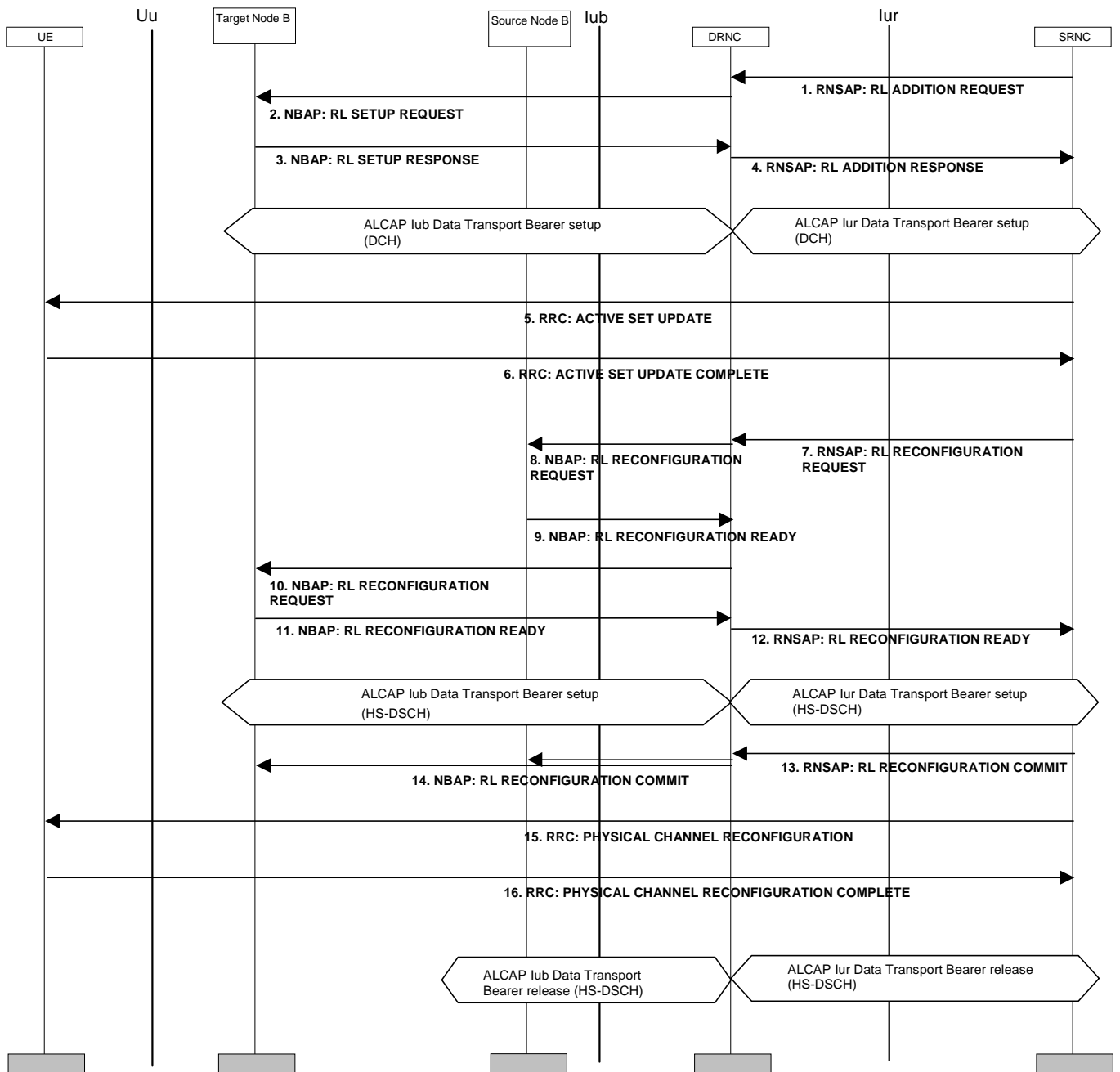

Figure 6: Inter-Node B serving HS-DSCH cell change after radio link addition

1. The SRNC decides there is a need for an addition of a radio link, which would become the new serving HS-DSCH cell. As a first step the SRNC requests the DRNC to establish the new radio link without the HS-DSCH resources by transmitting a RADIO LINK ADDITION REQUEST message to the DRNC.
2. The DRNC allocates radio resources for the new radio link and requests the target Node B to establish a new radio link by transmitting a RADIO LINK SETUP REQUEST message including the necessary parameters for DPCH establishment.
3. The target Node B allocates resources, starts physical layer reception on the DPCH on the new radio link and responds with RADIO LINK SETUP RESPONSE message.
4. The DRNC responds to the SRNC with RADIO LINK ADDITION RESPONSE message. The DCH transport bearer is then established.

5. The SRNC prepares an ACTIVE SET UPDATE message and transmits it to the UE. The message includes an identification of the radio link to add.
6. The UE adds the new radio link to its active set and returns an ACTIVE SET UPDATE COMPLETE message to the SRNC.
7. As the next step, the SRNC prepares a RADIO LINK RECONFIGURATION PREPARE message which is transmitted to the DRNC. The message indicates the target HS-DSCH cell.
8. If we assume the source and target HS-DSCH cells are controlled by different Node Bs, the DRNC requests the source HS-DSCH Node B to perform a synchronised radio link reconfiguration using the RADIO LINK RECONFIGURATION REQUEST message, removing its HS-DSCH resources for the source HS-DSCH radio link.
9. The source Node B returns a RADIO LINK RECONFIGURATION READY message.
10. The DRNC requests the target HS-DSCH Node B to perform a synchronised radio link reconfiguration using the RADIO LINK RECONFIGURATION REQUEST message, adding HS-DSCH resources for the target HS-DSCH radio link. The message includes also necessary information to setup the HS-DSCH resources in the target HS-DSCH cell, including a DRNC selected HS-DSCH UE identity.
11. The source HS-DSCH Node B returns a RADIO LINK RECONFIGURATION READY message.
12. The DRNC returns a RADIO LINK RECONFIGURATION READY message to the SRNC. The message includes HS-SCCH set info, scrambling code for the target HS-DSCH cell and the HS-DSCH UE identity.
13. The HS-DSCH transport bearer to the target HS-DSCH Node B is established. The SRNC proceeds by transmitting RADIO LINK RECONFIGURATION COMMIT message to the DRNC including an SRNC selected activation time in form of a CFN.
14. The DRNC transmits RADIO LINK RECONFIGURATION COMMIT messages to the source HS-DSCH Node B and the target HS-DSCH Node B including the activation time. At the indicated activation time the source HS-DSCH Node B stops and the target HS-DSCH Node B starts transmitting on the HS-DSCH to the UE.
15. The SRNC also transmits a PHYSICAL CHANNEL RECONFIGURATION message to the UE. The message includes activation time, MAC-hs reset indicator, serving HS-DSCH radio link indicator, HS-SCCH set info and HS-DSCH UE identity.
16. At the indicated activation time the UE resets MAC-hs, stops receiving HS-DSCH in the source HS-DSCH cell and starts HS-DSCH reception in the target HS-DSCH cell. The UE returns a PHYSICAL CHANNEL RECONFIGURATION COMPLETE message to the SRNC. The HS-DSCH transport bearer to the source HS-DSCH Node B is released.

6.2.5 Open Issues

6.3 Impacts on Iub Interface User Plane Protocols

6.3.1 Transport Bearer Options

6.3.1.1 Option 1 - One Transport Bearer per HS-DSCH Transport Channel

6.3.1.1.1 Frame Protocol Aspects for HS-DSCH

Node B with HSDPA has several functions which are similar to the DRNC functions with DSCH in the following aspects:

- it handles a certain pool of code and power resources autonomously, like the DRNC,
- it performs several traffic management functions (e.g. code mapping, scheduling) like the DRNC, and
- it controls MAC-d flows over Iub (rather than Transport Block streams), just as a DRNC controls MAC-c/sh SDU data flows across Iur.

We focus on the latter observation to stress that the Iub interface with HSDPA should be compared to the Iur (rather than Iub) interface with DSCH and that the Iur behaviour with HSDPA should be identical to the Iur behaviour with DSCH.

Assuming that each HS-DSCH MAC-d flow is carried on a separate Iub/Iur transport bearer (Figure 2), then the Data and Control Frame formats for the HS-DSCH Frame Protocol over Iub/Iur could be almost the same as their DSCH equivalents over Iur, the only exception being the following:

- 1) CmCH-PI may have to be replaced by Priority Queue ID (FFS), and
- 2) MAC-c/sh SDU is renamed MAC-d PDU.

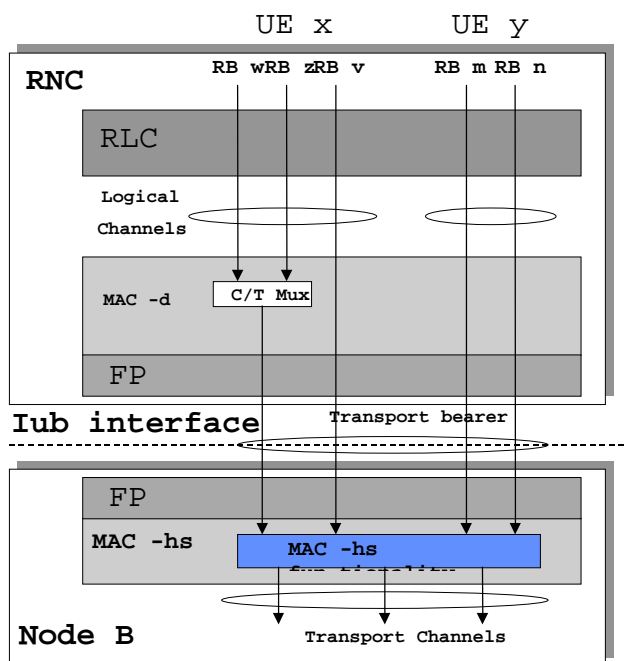

Figure 2: The case which no MAC level multiplexing is allowed over Iub

6.3.1.1.2 Data Frame Format for HS-DSCH Frame Protocol

The HS-DSCH data frames have almost the same format as their DSCH counterparts.

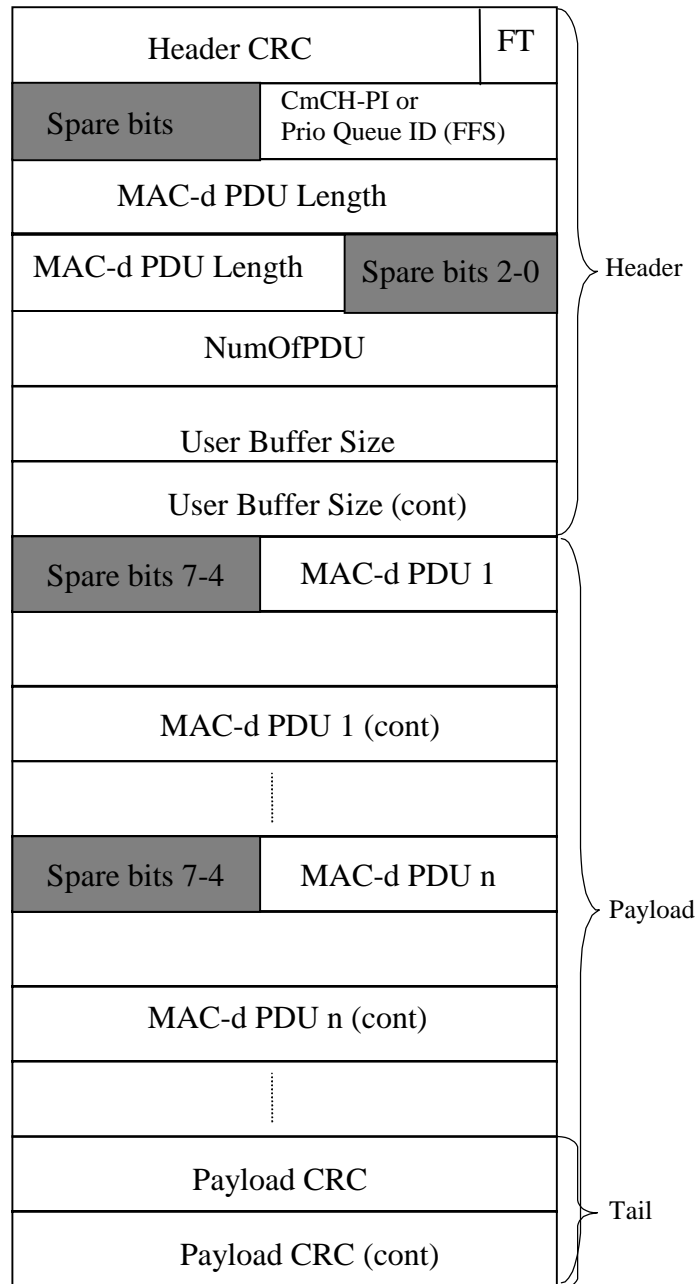

Figure 5: HS-DSCH Iur/Iub Data Frame structure

Header CRC - Cyclic Redundancy Checksum calculated on the header of a data frame with a polynomial.

CmCH-PI - The *Common Transport Channel Priority Indicator* IE indicates the priority of the data frame and the SDUs included which are waiting in the SRNC's Tx buffer for transmission via the HS-DSCH. As in case of the HS-DSCH on Iur, the *CmCH-PI* is in the range 0 to 15, where 0 means lowest priority and 15 is the highest priority.

Priority Queue ID - This field identifies the MAC-hs Priority Queue in the Node B to which the MAC-d PDUs in this frame should be delivered. The Priority Queue ID is allocated by SRNC via NBAP/RNSAP procedures.

FT - Describes if it is a control frame or a data frame.

NumOfPDU - Indicates the number of MAC-d PDUs in the payload.

User Buffer Size - Indicates the users' buffer size in octets for a given Common Transport Channel Priority (or Priority Queue).

MAC-d PDU – same as MAC-hs SDU.

Payload CRC - Cyclic Redundancy Checksum calculated on the header of a data frame.

Spare Extension - Indicates the location where new IEs can in the future be added in a backward compatible way.

6.3.1.1.3 Control Frame Format for HS-DSCH Frame Protocol

The flow control mechanism for HSDPA is based on two Control Frames:

- HS-DSCH Capacity Request, and
- HS-DSCH Capacity Allocation.

The HS-DSCH Capacity Request/Allocation control frames have almost the same format as their DSCH counterparts.

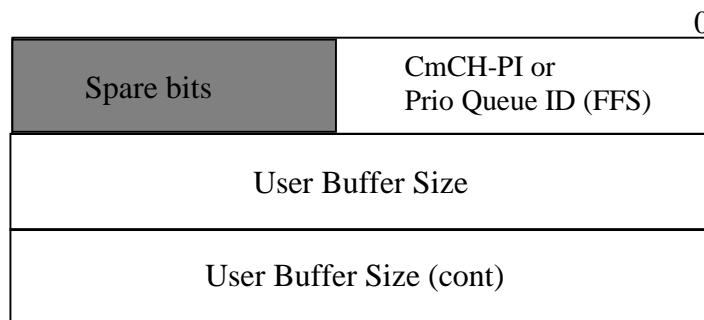

Figure 3: HS-DSCH Capacity Request Control Frame

CmCH-PI - The *Common Transport Channel Priority Indicator* IE indicates the priority of the data frame and the SDUs included which are waiting in the SRNC's Tx buffer for transmission via the HS-DSCH. As in the case of the DSCH on Iur, the *CmCH-PI* is in the range 0 to 15, where 0 means lowest priority and 15 is the highest priority.

Priority Queue ID - The *Priority Queue ID* indicates the Priority Queue for which the User Buffer Size information is provided.

User Buffer Size - Indicates the users' buffer size (i.e. the amount of data in the buffer in the SRNC) in octets for the indicated Common Transport Channel Priority (or Priority Queue).

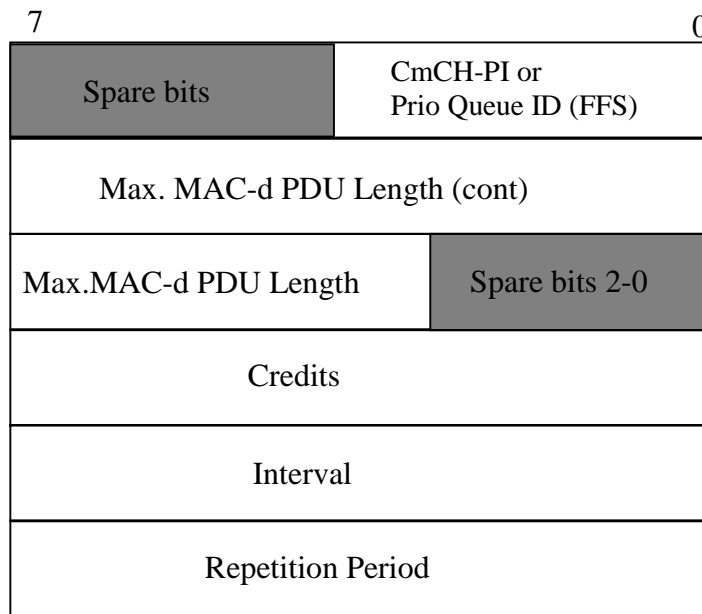

Figure 4: HS-DSCH Capacity Allocation Control Frame

CmCH-PI - The *Common Transport Channel Priority Indicator* IE indicates the priority of the PDUs for which credit (a transmission permit) is allocated with that message.

Priority Queue ID - The *Priority Queue ID* indicates the Priority Queue in the Node B for which credit (a transmission permit) is allocated with this message.

Max MAC-d PDU Length - The value indicates the maximum allowable MAC-d PDU size. MAC-d PDU contains the C/T field of the MAC header followed by one RLC PDU Field length: See the value of the *MAC-d PDU Length* IE.

Credits - The *Credits* IE indicates the number of MAC-d PDUs that a user may transmit for the indicated CmCH-PI (or Priority Queue ID).

Interval - The value of this field indicates the time interval during which the Credits granted in the HS-DSCH Capacity Allocation frame may be transmitted.

Repetition period - The value of this field indicates the number of subsequent intervals that the Credits granted in the HS-DSCH Capacity Allocation frame may be transmitted.

6.3.1.1.4 Open Issues

6.3.1.2 Option 2 - One Transport Bearer for Multiple MAC-d flows for Multiple UE's

6.3.1.2.1 Frame Protocol Aspects for HS-DSCH

This alternative is to allow multiple UEs to share the same transport bearers over Iub. Therefore transport bearers can be configured based on following factors,

- number of cells in Node-B i.e. if Node-B supports more than one cell => one transport bearer / cell
- priorities => transport bearer / priority
- only one transport bearer / Node-B
- the number of HSDPA related physical channels on Node-B.
- etc.

In order to allow multiple MAC-d flows to use the same transport resources on Iub-interface, the MAC-d flows multiplexing - currently UE-ID multiplexing is provided only for the common channels (FACH/RACH)- should be adopted for the HSDPA related channels on Iub. In practice this means that either the services of the MAC-c/sh is needed, or if the multiplexing is provided on the FP level a new MAC-d flow multiplexing functionality is required on the FP layer.

Figure 6 presents the models where the MAC-d flow Mux is provided either on the MAC-c/sh or on the FP layer respectively.

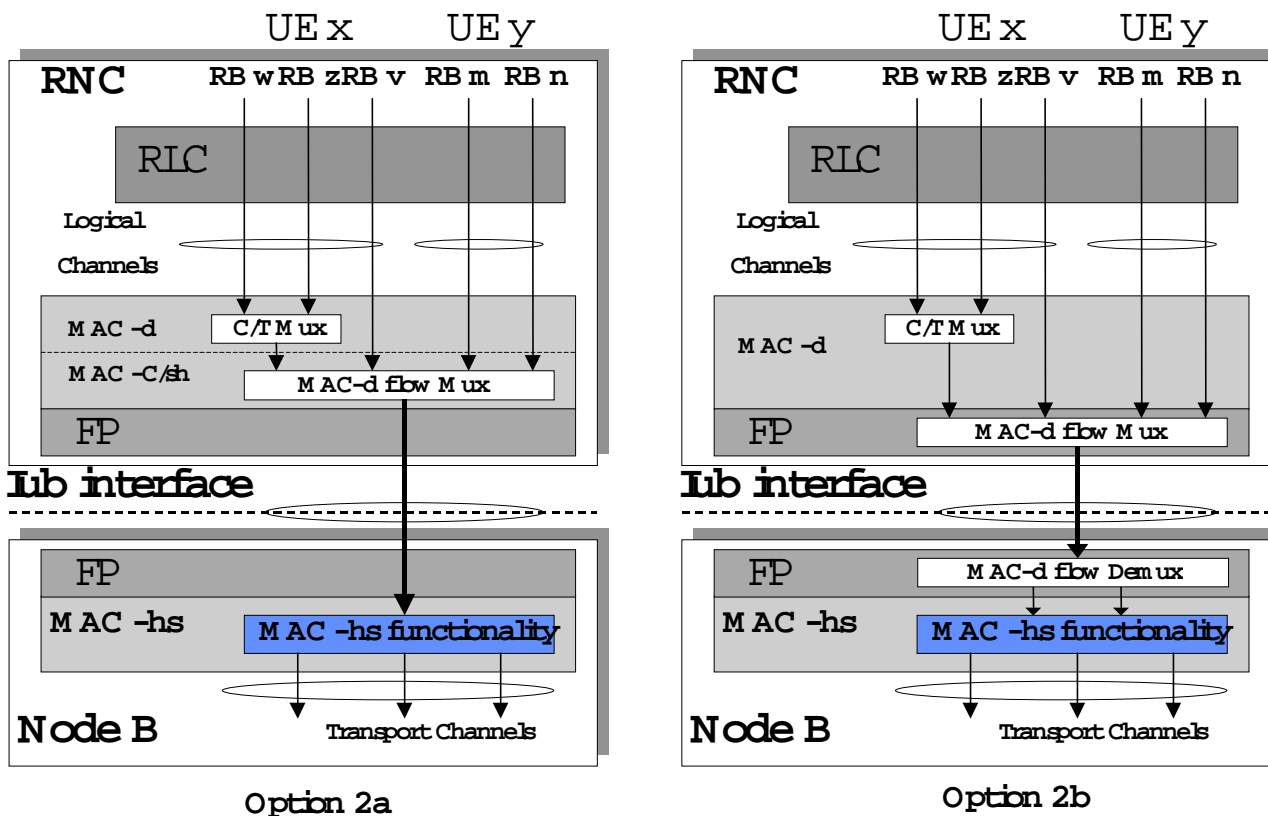

Figure 6: The case which MAC level multiplexing is allowed over Iub

In the option 2a (*not the current RAN2 assumption*), the MAC-d flow Mux could be based on the use of the RNTI in the MAC header. This method is already being used for common channels and it doesn't introduce anything new to the MAC-c/sh. In the option 2b, the MAC-d flow Mux is moved to the FP layer, where the MAC-d flow Mux could be based either on RNTI or on a new identification in addition to MAC-d Flow ID, which needs to be defined on the FP layer for this purpose.

It is noted that option 2b is preferable considering the interaction with RAN2 and the work load.

6.3.1.2.2 Data Frame Format for HS-DSCH Frame Protocol

The HS-DSCH FP facilitates multiplexing of data streams from different UEs onto the same data frame and allows multiple UEs and multiple MAC-d flows to share the same transport bearer.

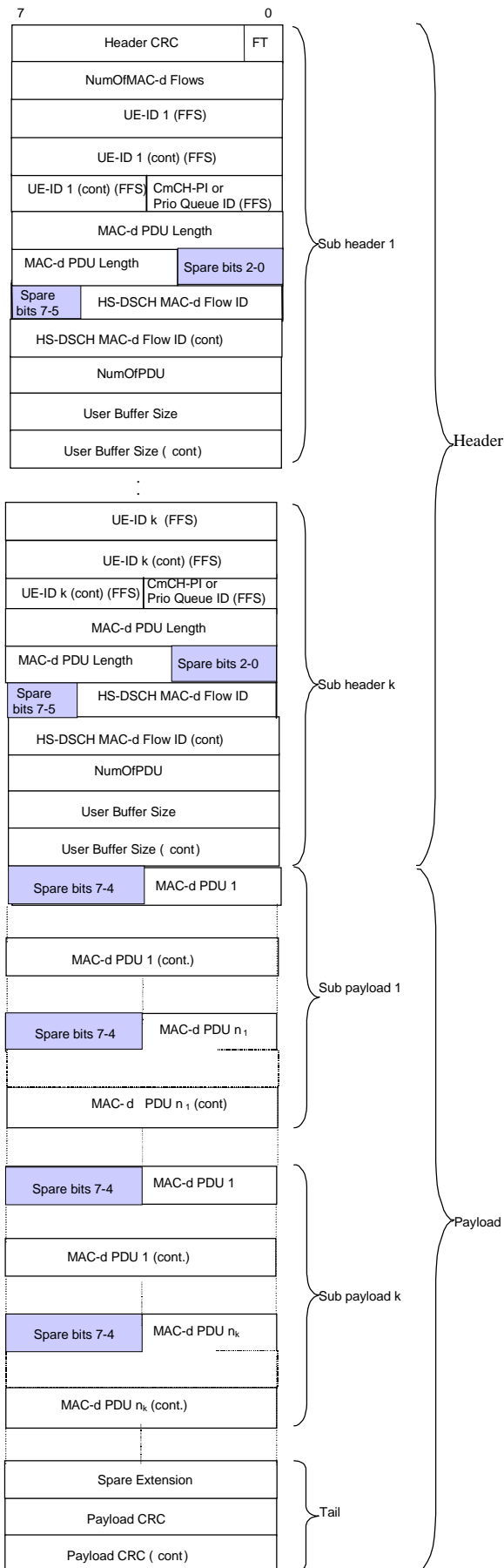

Figure 7: HS-DSCH Iur/Iub Data Frame Structure

Header of data frame consists of NumOfMAC-d Flows and 1 to k sub-headers of data streams for each MAC-d flow. In the payload are placed sub-payloads for each UE-ID and HS-DSCH MAC-d Flow ID combination.

6.3.1.2.2.1 Coding of information elements in data frames

Header CRC

Description: Cyclic Redundancy Checksum calculated on the header of a data frame with polynomial $X^7+X^6+X^2+1$. The CRC calculation shall cover all bits in the header, starting from bit 0 in the first byte (FT field) up to the end of the header.

Value range: {0-127}.

Field length: 7 bits.

Frame Type (FT)

Description: describes if it is a control frame or a data frame.

Value range: {0=data, 1=control}.

Field Length: 1 bit.

NumOfMAC-d Flows

Description: Indicates the number of MAC-d Flows in the payload.

Value range: {1-255}.

Field Length: 8 bits.

UE-ID (FFS)

As UE-ID is proposed to use DRNTI. Using proprietary UE-ID for FP is FFS.

Description: Identifies the UE in the DRNC.

Value range: {0-1048575}.

Field length: 20 bits.

Common Transport Channel Priority Indicator (CmCH-PI)

Description: CmCH-PI is the relative priority of the data frame and the SDUs included.

Value range: {0-15, where 0=lowest priority, 15=highest priority}.

Field length: 4 bits.

Priority Queue ID

Same definition with the one in section 6.3.1.1.2

MAC-d PDU Length

Description: The value of that field indicates the size of MAC-d PDU.

Value range: Same value range with the one in option 1.

Field Length: Same length with the one in option 1

HS-DSCH MAC-d Flow ID

Description: The value of that field indicates which MAC-d flow this PDU belongs to.

Value range: Same value range with the one in NBAP will be defined.

Field Length: FFS

NumOfPDU

Description: Indicates the number of MAC-d PDUs in the payload.

Value range: {1-255}.

Field Length: 8 bits.

User Buffer Size

Description: Indicates the users' buffer size (i.e. the amount of data in the buffer) in octets for a given Common Transport Channel Priority.

Value range: {0-65535}.

Field length: 16 bits.

MAC-d PDU

Description: Same as option 1.

Field length: Same as option 1.

Payload CRC

Description: Cyclic Redundancy Checksum calculated on the payload of a data frame with polynomial $X^{16}+X^{15}+X^2+1$. The CRC calculation shall cover all bits in the data frame payload, starting from bit 7 in the first byte up to bit 0 in the byte before the payload CRC.

Field length: 16 bits.

Spare Extension

Description: Indicates the location where new IEs can in the future be added in a backward compatible way.

Field length: 0-2 octets.

6.3.1.2.3 Control Frame Format for HS-DSCH Frame Protocol

In addition to the HS-DSCH Data Frame, all the control frames, which will be delivered over Iub HS-DSCH transport bearer, should be considered. Since in case HS-DSCH data frames may be multiplexed, and control frames also share the transport bearer, each control frame (Capacity Request, Capacity Allocation, ...) on HS-DSCH transport bearer should include UE-id and HS-DSCH MAC-d Flow ID.

6.3.1.2.4 Open Issues

- In case the CRNC indicates that the Node B may multiplex, can the Node B choose freely among the available transport bearers, or could there be limits regarding what level of multiplexing the CRNC can handle on each transport bearer
- Interaction between solutions performing UE multiplexing and direct SRNC-Node B bearers.

6.3.1.3 Inter-operability of Options 1 and 2

Both options 1 and 2 can exist together. In the case that either Node B or CRNC doesn't want to multiplex HSDPA data streams then a separate bearer will be set up for each HSDPA data stream. When the CRNC has to set up a HSDPA data stream over the Iub, it will inform the Node B a candidate list of transport bearer (This information implies whether Node B allows to multiplex or not). The Node B will then decide whether it wants to multiplex this data stream or not and in the case the Node B decides to multiplex, it will also choose the transport bearer to be shared among the one CRNC gave.

3 possible cases can be considered;

1. CRNC allows HSDPA data stream multiplexing and Node B decides to multiplex
2. CRNC allows HSDPA data stream multiplexing and Node B decides not to multiplex
3. CRNC doesn't allow HSDPA data stream multiplexing

Case 1 : Since both sides decide to multiplex, Node B chooses transport bearer to be shared and provides this information to the CRNC instead of new transport bearer information.

Case 2 : Since mux-option cannot be used, Node B provides new transport bearer information to CRNC.

Case 3 : Since mux-option cannot be used, Node B provides new transport bearer information to CRNC.

6.3.1.3.1 Signalling Flow Cases

6.3.1.3.1.1 CRNC allows HSDPA data stream multiplexing and Node B decides to multiplex (Case 1)

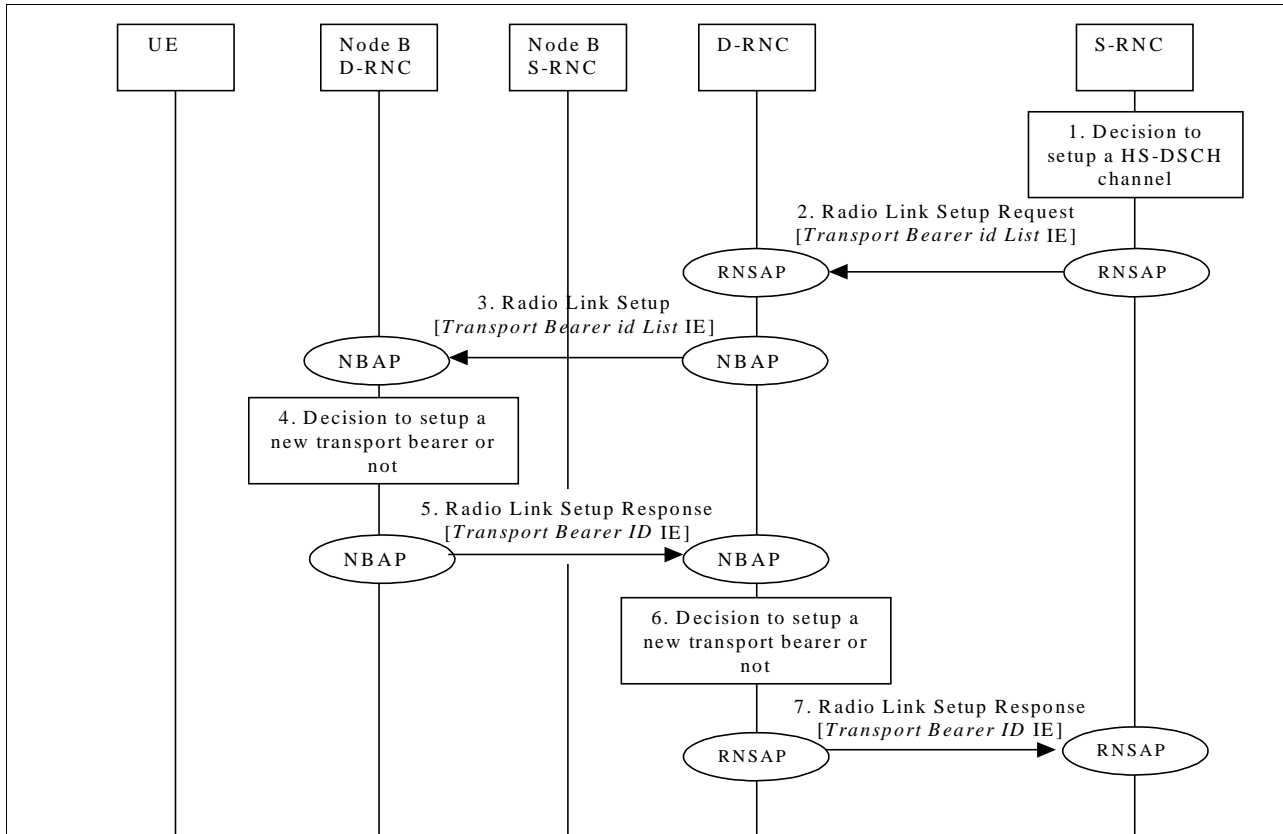

Figure 8: Node B decides to Multiplex

1. SRNC needs to set up a HS-DSCH channel.
2. SRNC sends RADIO LINK SETUP REQUEST message to DRNC with *Transport Bearer id List IE*. *Transport Bearer id List IE* shows which transport bearer can be shared as well as whether this data stream may be multiplexed or not. In this example *Transport Bearer id List IE* has more than zero transport bearer id. (Mux option over Iur is FFS.)
3. DRNC sends RADIO LINK SETUP REQUEST message to Node B with *Transport Bearer id List IE*. *Transport Bearer id List IE* shows which transport bearer can be shared as well as whether this data stream may be multiplexed or not. In this example *Transport Bearer id List IE* has more than zero transport bearer id.
4. Node B decides if mux option will be used or not. In this example Node B decides to multiplex.
5. Node B chooses a transport bearer to be shared among the transport bearer ids in the list received and replies with the transport bearer ID.
6. DRNC decides if mux option will be used or not. In this example DRNC decides to multiplex. (Mux option over Iur is FFS.)
7. DRNC chooses a transport bearer to be shared among the transport bearer ids in the list received and replies with the transport bearer ID.

6.3.1.3.1.2

CRNC allows HSDPA data stream multiplexing and Node B decides not to multiplex (Case 2)

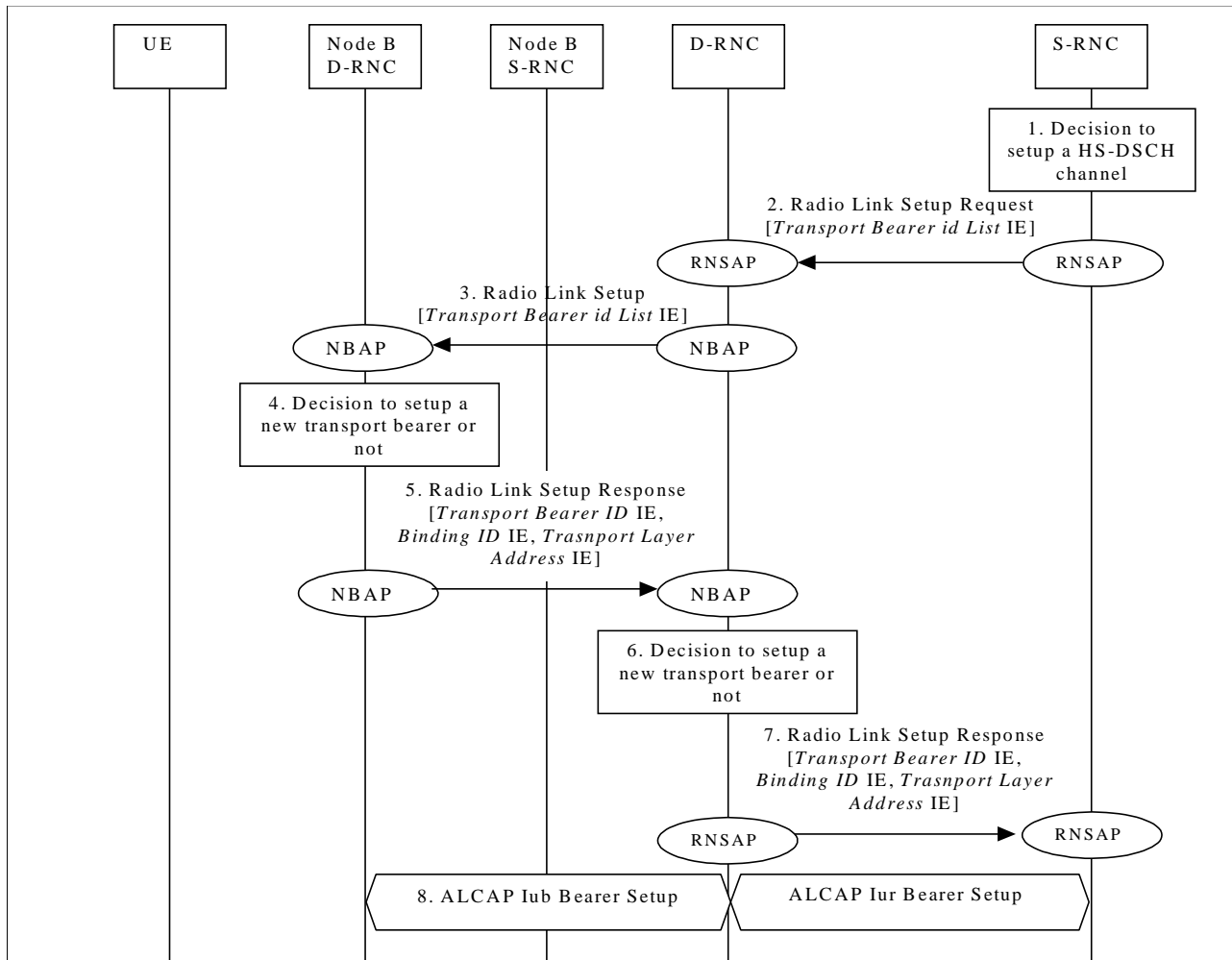

Figure 9: Node B decides not to multiplex

1. SRNC needs to set up a HS-DSCH channel.
2. SRNC sends RADIO LINK SETUP REQUEST message to DRNC with *Transport Bearer id List IE*. *Transport Bearer id List IE* shows which transport bearer can be shared as well as whether this data stream may be multiplexed or not. In this example *Transport Bearer id List IE* has more than zero transport bearer id. (Mux option over Iur is FFS.)
3. DRNC sends RADIO LINK SETUP REQUEST message to Node B with *Transport Bearer id List IE*. *Transport Bearer id List IE* shows which transport bearer can be shared as well as whether this data stream may be multiplexed or not. In this example *Transport Bearer id List IE* has more than zero transport bearer id.
4. Node B decides if mux option will be used or not. In this example Node B decides not to multiplex.
5. Node B replies with a new transport bearer ID as well as new transport information.
6. DRNC decides if mux option will be used or not. In this example DRNC decides not to multiplex. (Mux option over Iur is FFS.)
7. DRNC replies with a new transport bearer ID as well as new transport information.
8. New transport bearers over Iub/Iur set up.

6.3.2 Flow Control Options

This study area is intended to describe the various proposed solutions for the flow control mechanism for HSDPA.

6.3.2.1 Option 1 - Credit Based Flow Control

The need is foreseen to introduce flow control on the Iub and Iur interfaces. It can be introduced either directly between the SRNC and the Node B in order to reduce transmission time delay or separately on both the Iub and Iur interfaces. In both cases, the same structure shall be used over Iub and Iur for the control frames. Therefore, the control frames can either be sent through the CRNC transparently and no RNL multiplexing of HS-DSCH transport channels is performed across the Iub/Iur or the control frames can be sent from the SRNC to the DRNC and from the DRNC to the Node B (if there is a DRNC involved).

The same flow control mechanism with small modifications is proposed to be used for HS-DSCH data streams on the Iub/Iur interface as in R99 for the DSCH data streams on the Iur interface. The flow control is done via exchange of HS-DSCH Capacity Request and HS-DSCH Capacity Allocation frames between the Node B and SRNC for a given priority group. The data transfer is done via transfer of HS-DSCH Data Frames from the SRNC to the Node B for a given priority group. The flow control frames and data transfer frames that are used over the Iur and Iub interfaces shall be of the same format. The small modifications shall be applied for parameters in the HS-DSCH Capacity Allocation frame- a parameter to indicate the maximum MAC-hs SDU length is probably not needed (because in one HS-DSCH, a constant Transport Block Size is used which fits to a constant MAC-hs SDU size) and the value range of the *Credits* IE should be probably increased (FFS).

The following three sections present parameters for the HS-DSCH Capacity Request, HS-DSCH Capacity Allocation, and HS-DSCH Data Frames. These frames have the same structure, this whatever the chosen flow control option: the (A,B) couple can either be (SRNC,Node B) if the flow control is directly between the SRNC and the Node B or (SRNC,DRNC) & (CRNC,Node B) if the flow control is handled separately on Iur and Iub.

6.3.2.1.1 HS-DSCH Data Transfer

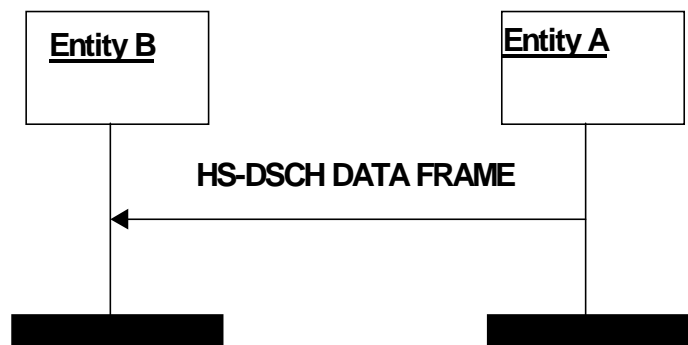

Figure 12: HS-DSCH Data Transfer

Header CRC - Cyclic Redundancy Checksum calculated on the header of a data frame with a polynomial.

CmCH-PI - The *Common Transport Channel Priority Indicator* IE indicates the priority of the data frame and the SDUs included which are waiting in the Entity A's Tx buffer for transmission via the HS-DSCH. As in case of the DSCH on Iur, the *CmCH-PI* is in the range 0 to 15, where 0 means lowest priority and 15 is the highest priority.

FT - Describes if it is a control frame or a data frame.

MAC-c/hs SDU Length - The value of that field indicates the length of every MAC-c/hs SDU in the payload of the HS-DSCH data frame in number of bits.

NumOfSDU - Indicates the number of MAC-hs SDUs in the payload.

User Buffer Size - Indicates the users' buffer size in octets for a given Common Transport Channel Priority.

MAC-hs SDU - A MAC-hs SDU contains the C/T field of the MAC header followed by one RLC PDU.

Payload CRC - Cyclic Redundancy Checksum calculated on the header of a data frame.

Spare Extension - Indicates the location where new IEs can in the future be added in a backward compatible way.

6.3.2.1.2

HS-DSCH Capacity Request

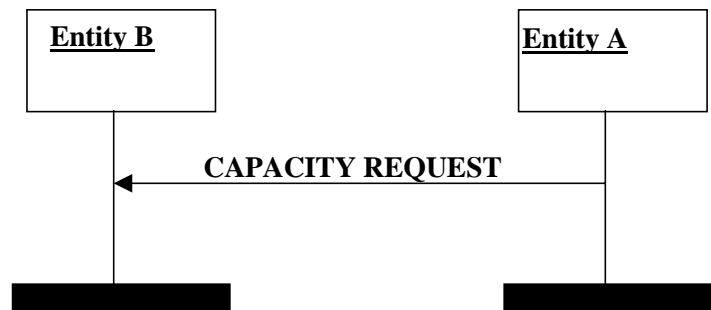

Figure 10: HS-DSCH Capacity Request

CmCH-PI - The *Common Transport Channel Priority Indicator* IE indicates the priority of the data frame and the SDUs included which are waiting in the Entity A's Tx buffer for transmission via the HS-DSCH. As in the case of the DSCH on Iur, the *CmCH-PI* is in the range 0 to 15, where 0 means lowest priority and 15 is the highest priority.

User Buffer Size - Indicates the users' buffer size (i.e. the amount of data in the buffer in the Entity A) in octets for the indicated Common Transport Channel Priority.

6.3.2.1.3

HS-DSCH Capacity Allocation

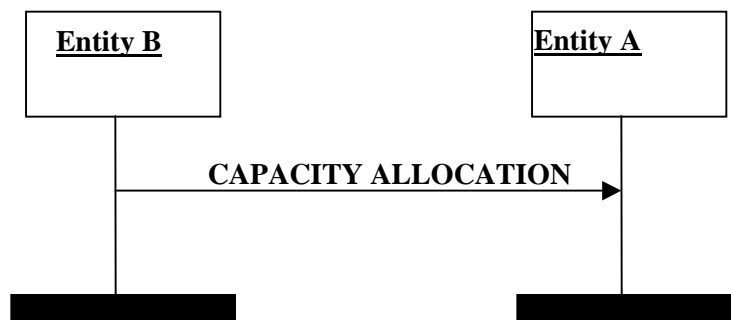

Figure 11: HS-DSCH Capacity Allocation

CmCH-PI - The *Common Transport Channel Priority Indicator* IE indicates the priority of the SDUs for which credit (a transmission permit) is allocated with that message. This means that the Entity A can use this credit value only for sending SDUs with exactly that indicated *CmCH-PI*. If the Entity A were to send SDUs with a higher or lower *CmCH-PI*, and if there were no allocated credit for these deviated *CmCH-PI* values, the Node B would have the right to ignore these SDUs, i.e. to refrain from processing and forwarding them.

Credits - The *Credits* IE indicates the number of MAC-hs SDUs that a user may transmit with the indicated *CmCH-PI*.

Interval - The value of this field indicates the time interval during which the Credits granted in the HS-DSCH Capacity Allocation frame may be transmitted.

Repetition period - The value of this field indicates the number of subsequent intervals that the Credits granted in the HS-DSCH Capacity Allocation frame may be transmitted.

Max. MAC c/sh SDU length - probably obsolete [FFS]

6.4 QoS Aspects

{This section should describe the QoS aspects associated with HSDPA.}

6.5 TDD versus FDD Aspects

{This section should describe the differences in architecture between TDD and FDD mode. This section should also describe any specific TDD changes that are needed for HSDPA.}

6.6 Backwards Compatibility

{This section should identify backwards compatibility issues when introducing the HSDPA functionality into RAN3. The goal is to ensure that there are no backwards compatibility issues.}

7 Agreements and associated contributions

- We will have in Release-5, 1 MAC-d flow per transport bearer. Further study required for having more than 1 MAC-d flows per transport bearer

8 Specification Impact and associated Change Requests

Table 1: Affected Release 5 specifications and the related Change Requests

3G TS	CR	Title	Remarks
3G TS 25.401	039r2	UTRAN Overall Description	
3G TS 25.420	023r1	UTRAN Iur Interface General Aspects and Principles	
3G TS 25.423	570r3	UTRAN Iur Interface RNSAP Signalling	
3G TS 25.425	044r2	UTRAN Iur Interface User Plane Protocols for Common Transport Channel Data Streams	
3G TS 25.430	029r2	UTRAN Iub Interface, General Aspects and Principles	
3G TS 25.433	612r3	UTRAN Iub Interface NBAP Signalling	
3G TS 25.435	075r1	UTRAN Iub Interface User Plane Protocols for Common Transport Channel Data Streams	

History

Document history		
Date	Version	Comment
2001-07	V0.0.1	Initial Proposal
2001-07	V0.1.0	Version Agreed at RAN3#22 (Sophia Antipolis)
2001-08	V0.1.1	Version Agreed at RAN3#23 (Helsinki)
2001-10	V0.2.0	Version Agreed at RAN3#24 (New York)
2001-11	V0.3.0	Version Agreed at RAN3#25 (Makuhari)
2002-01	V0.4.0	Version Agreed at RAN3#26 (Vienna)
2002-02	V0.5.0	Version Agreed at RAN3#27 (Orlando)
2002-02	V0.5.1	Rapporteurs proposal of version 0.5.1 to be raised as version 1.0.0
2002-02	V1.0.0	Version e-mail approved by RAN WG3
2002-02	V2.0.0	Version e-mail approved by RAN WG3
Rapporteur for 3GPP TR 25.877 is: Michael Diesen		
Tel. : +1-847-632-6137 Fax : +1-847-632-2574 Email : Michael.J.Diesen@motorola.com		
This document is written in Microsoft Word 2000.		