

TSG-RAN Meeting #12

RP-010413

12 – 15 June 2001, Stockholm, Sweden

Source: Tekmar Sistemi

Title: WI Description Sheet for
UTRA Wideband Distribution Subsystems (WDS)

Document for: **Submission**

This contribution contains the Work Item Sheet Description on UTRA Wideband Distribution Subsystem, following the outcome of the discussion and further Chairman' indications at RAN4 #17.

Documents presented at RAN4 #17 are attached.

Work Item Description

Title UTRA Wideband Distribution Subsystems (WDS)

1 3GPP Work Area

X	Radio Access
	Core Network
	Services

2 Linked work items

none

3 Justification

This Work Item Description follows a discussion held at RAN4 #17 on annex Tdoc R4-010668.

R4-010668 proposes the introduction of a new class of equipment that would allow for improved flexibility of radio access network solutions, here called *Wideband Distribution Subsystem, or WDS* - including its generic interface to the UTRA FDD Node B. TDD applicability is possible and will be considered at a later stage. WDS are a capable of flexible remoting of multiple Node B's RF interface, on a possible multi-operator, multi-vendor scenario, both for indoor and outdoor applications while granting substantially compliant Node B performance.

In many cases existing 2G WDS were accepted for network integration under Operator's direct responsibility, as existing specifications were not addressable for clearly and neatly defining equipment reference specification and network integration techniques, with even more severe issues in case of a multi-operator application scenario.

4 Objective

A technical specification should be created for the interfaces from WDS to the rest of the radio access network, and minimum requirements for conformance testing in a multicarrier environment, e.g.:

- Linearity
- Output power
- Occupied bandwidth
- Adjacent channel leakage ratio
- Spurious emissions
- Transmit intermodulation
- Transmit modulation accuracy
- Reference sensitivity level
- Blocking characteristics
- Intermodulation characteristics

These characteristics should be defined considering WDS as ancillary equipment on a multi-vendor Node B scenario. Therefore, some conformance test requirements could be different from the standard Node B requirements and may not require full Node B conformance testing.

Additionally, the requirements for an optional communication interface (e.g. for monitoring and configuration purposes) between WDS and other network elements, shall be defined.

RAN4 #17 concluded that first required action to clarify the rationale for WDS is a Feasibility Study. Its submission and relevant discussion is planned for RAN4 #18.

5 Service Aspects

There could be service aspects to be considered, i.e. impact on LCS, but so far they are unknown. The Feasibility Study should clarify this aspect.

6 MMI-Aspects

None

7 Charging Aspects

None

8 Security Aspects

None

9 Impacts

Affects:	USIM	ME	AN	CN	Others
Yes			X		
No	X	X		X	
Don't know					X

10 Expected Output and Time scale (to be updated at each plenary)

New specifications						
Spec No.	Title	Prime resp. WG	2ndary resp. WG(s)	Presented for information at plenary#	Approved at plenary#	Comments
T.b.d.		WG4		RAN13	RAN14	Wideband Distribution Subsystem
T.b.d.		WG4		RAN13	RAN14	Wideband Distribution Subsystem conformance testing
Affected existing specifications						
Spec No.	CR	Subject		Approved at plenary#	Comments	

11 Work item rapporteurs

t.b.d. (name of physical person)

12 Work item leadership

TSG-RAN WG4

13 Supporting Companies

Agilent
Marconi Wireless
Mitsubishi Electric Telecom
Ntl
Orange
Tekmar Sistemi
Telecom Italia
Telefonica
Telia Mobile

14 Classification of the WI

	Building Block (go to 14b)
--	----------------------------

14b The WI is a Building Block: parent Feature is Radio Interface Improvement Feature

Source: Tekmar

Title: Technical justification and overall advantages for UTRA
Wideband Distribution Subsystems (WDS)

Document for: Discussion

1. Introduction

Node B are available from some manufacturers with ancillary Radio Remote Heads including RF low-power or baseband proprietary interface, that provide possibilities for optimising microcellular sites. These solutions are usually suitable for only few RF carriers and are seen as integral part of Node B.

In order to allow for an improved flexibility of radio access network solution, we propose to define a new type of equipment, here called *Wideband Distribution Subsystem, or WDS* -including its generic interface to the UTRA FDD Node B. TDD applicability is possible and will be considered at a later stage.

The so-defined subsystem shall include one or multiple RF front-ends, RF transmission, and interfaces capable of supporting one or multiple Node B; its functionality shall be essentially transparent for use with multi-carrier WCDMA signals, in order to maintain full compliance to the standard in the coverage area. Other ancillary functions may be included as required for best system integration.

Benefits brought by WDS are summarised:

- Possible Node B and RNC co-location in centralised equipment locations –Hub sites, for increased implementation flexibility and trunking efficiency
- Distributed RF wideband microcellular heads –RF nodes, with lower RF transmission power to cope with most stringent environmental compatibility requirements
- Better and easier flexibility in network planning and upgrading, and on capacity and location systems implementation
- Increased protection from co-channel and adjacent channel (intra-networks) interference
- Sharing opportunities, leading to reduced visual impact on the environment by placing multiple operators on the same structure with significant opportunity for cost reduction
- Faster and easier network rollout and maintenance

2. WDS description

The present structure of 3GPP UTRA RAN specifications includes Node B (TS 25.104 [ref.1] / TS 25.141 [ref.2]) and Repeaters (TS 25.106 [ref.3]/ TS 25.143 [ref.4]).

Node B can sometime include Ancillary Equipment like masthead amplifiers or remote radio heads, that are convenient for adding flexibility and reduce cost of installation.

These solutions are embedded in Node B as ancillary RF amplifiers and are therefore seen as integral part of it in a single-vendor deployment scenario.

WDS are altogether similar devices, capable of remotisation of Node B's RF interface, but offering flexible and multiple RF interface to Node B, or to sub-equipped Node B (e.g. not including MCPAs and diplexers). WDS include all required functions.

Because of the very specific features and possibilities offered by WDS, they obviously cannot be considered as integral part of Node B; in the other hand they are very different from repeaters and cannot be classified as such. Specific technical details are addressed in following Section 3.

Figure 1 depicts a simple overall diagram for WDS and its interfaces.

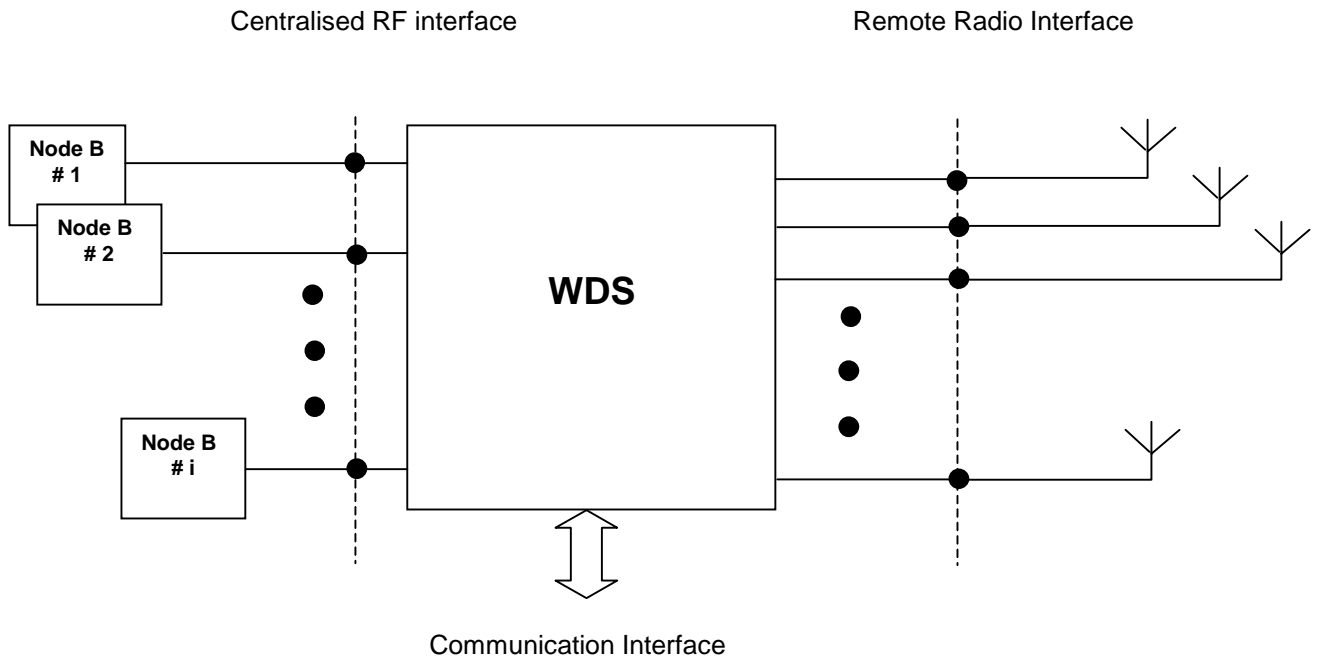

Figure 1

WDS generally include a number of functions that are required for correct operation. Those functions are listed and described here below:

Function Definition	Function Description
Centralised RF interface	It provides RF independent and interference-free interface to multiple Nodes B, that possibly belong to more than one Network Operator. RF power at interface can be in the range of milliwatts.
Transmission	It provides the proper multi-carrier, multi-vendor link to a number of remotely placed sites that host suitable RF amplifiers and other devices (RF front-end) for achieving planned capacity and coverage. Examples of available technologies are with various fibre-radio techniques, including WDM and DWDM
RF transmit amplifier	It boosts all available RF channels in the downlink direction, and therefore shall offer high linearity in a multi-carrier scenario. Power classes can be defined on a wide range
RF receive amplifier	It boosts uplink signals before they are transmitted back to Node B receivers.
RF filtering/diplexing	It provides a common TX/RX antenna connector at the remote site, and includes proper selectivity for achieving interference protection as required in the various deployment scenarii.
Power supply	Different PS units support the subsystem at Node B location and at remote locations with adequate redundancy. Primary power source can be flexibly defined
Ancillary functions	A range of ancillary and optional functions can be defined, e.g. diversity, alarms, and supervision

Table 1

3. WDS performance discussion

WDS data are extracted from Technical Annex.

1. WDS are physically connected to Node B according to capacity and coverage planning requirements. They are NOT used on simulcasting configuration, and therefore provide consistent and reliable performance as integral part of the access network, including minimisation of uncertainties in UE location;
2. Because of the tight interface to node B, WDS have low or moderate RF gain. Therefore they don't need complex filtering techniques to provide control of in-band and out-of-band spurious emissions; additionally, WDS allow for controlled and reliable performance in both single- and multi-vendor scenarii, leading to ease of planning; similarly, a reliable alarm and management interface can be provided as an option;
3. WDS show quite large in-band Dynamic Range, in line with Node B performance and substantially larger than RF repeaters; incremental Time Delay due to the equipment - excluding transmission- is negligible: following Table 2 compares DR for Node B, WDS, and Repeaters, the first as a derived from Node B RF specifications in TS 25.104 v.3.5.0, the latter as extracted from assumed values in TR 25.956 v.0.2.0 [ref.5]. Table 3 specifies incremental TD for WDS.

Dynamic Range

	Node B	WDS	Repeater
Transmit path (DL)	116dB	127dB	109dB
Measured as distance in dB between output power and background noise in 1Hz bandwidth for comparable output power levels in the three cases: Po_Node B = 31dBm Po_WDS = 32dBm Po_Rpt = 30dBm			
Receive path (UL)	129dB	143dB	91dB
Measured as distance in dB between input noise level in 1 Hz bandwidth and blocking level – Node B and Repeaters are assumed with NF= 5dB			

Table 2

WDS Incremental Time Delay

Node B interface	WDS transmission	WDS RF Head
<<1 microSec	5 microSec/Km*	<<1microSec

Note *: length of optical fibre cable used for transmission, velocity factor = 0.65

Table 3

4. Standard technologies provide WDS instantaneous bandwidth capability to cope with UMTS UTRA FDD full band application, including the various regional requirements;
5. WDS allow Node B -and RNC- to be co-located at centralised equipment locations, where upgrades and implementations can be effected with no requirement to visit remote sites. WDS can also provide flexible routing of different cells to different locations according to changing requirements in users profile and services impacting on network capacity.

The above listed items show WDSs capability of supporting Node B performance, and their substantial difference from repeaters as the latter are stand-alone devices with little network integration and critical deployment parameters to be considered, e.g. donor and coverage antennae isolation, adjacent channel rejection, co-channel interference amplification.

WDS are meant as radio interface remotisers for one or more dedicated Node B, while Repeaters are meant for filling gaps and extending the coverage of existing cells.

4. Example of test results on WDS

A practical test of a 3G-specific WDS is provided as an example in Technical Annex, whose results were taken for performance discussion in previous Section 3. It can be used for reference of standard results with fibre based transmission techniques.

5. Situation of existing WDS in 2G environment

WDS are currently used in some 2G networks, with different tasks and network integration modalities varying by system, Country, and network operator. Most significant application examples are on capacity distribution and management in Australian AMPS and GSM networks [ref.6] and South Korea (CDMA).

WDS are also used in their lower power variant for in-building and street-level dedicated picocells distribution, with widespread examples available.

In most cases WDS were accepted for network integration under Operator's direct responsibility, as existing repeater specification –e.g. GSM 11.26 [ref.7] - was clearly not sufficient for univocally and reliably defining equipment reference specification and network integration techniques, with even worse situation in case of multi-vendor application.

Those Operators who wanted to define WDS as an element in their network, needed to write their own internal specification [ref.8].

6. Benefits connected with normalisation of WDS

A normalisation process of WDS in the UMTS UTRA scenario is recommended to remove the burden of additional responsibility that Operators are carrying in defining their own acceptance rules and deployment guidelines when adopting WDS.

Also, a clear specification allows for a more fair and open competition scenario between manufacturers, with obvious advantages.

As a consequence WDS will be more widely adopted and this would possibly enable to fulfil recent recommendations from the EU on network sharing by providing a common radio access solution, such as multi-operator and multi-vendor microcells; it allow for significant simplification of networks planning and rollout and create additional chances for equal-opportunity access, in conjunction with a significant advantage in common UE transmit power co-ordination and following reduction of intra-network interference issues, both in microcellular and in-building scenarios. In the other hand it won't create unnecessary bottlenecks in handling high capacity or high data rate services.

As a consequence of its adoption some of the obstacles and concerns related to building new sites or expanding existing antenna towers would be removed or minimised; therefore network operators may be enabled to better focus on efficiently deploying new services, while network manufacturers may likely see a boosted opportunity to shipping base stations and other network elements more quickly.

7. Summary and objectives

In this contribution we have provided initial information on UTRA WDS structure, performance, and examples.

We propose the incorporation of WDS into the Release 5 standard, with starting a specific Work Item aimed to the creation of the technical specification for the interfaces between the WDS and the rest of the radio access network.

A detailed analysis shall be carried for any possible impact the new type of equipment may have on radio access network performance e.g. additional time delay, with specific attention to those aspects associated with location based services.

The work output shall also include the appropriate set of requirements for independent testing of that equipment, starting from similar items as described in TS 25.141.

Additionally, the requirements for an optional communication interface (e.g. for monitoring and configuration purposes) between the WDS and other network elements, shall be defined.

8. Planning proposal

The following high-level planning is proposed:

- Discussion at RAN4 # 17, 21-25 May 2001, Goteborg, Sweden
- Submission for acceptance at RAN plenary, 12-15 June 2001, Stockholm, Sweden
- Work Item development and completion for inclusion of WDS in Release 5 (end 2001)

9. References

- [1] TS 25.104 v.3.5.0
- [2] TS 25.141 v.3.2.0
- [3] TS 25.106 v.1.3.0
- [4] TS 25.143 v.1.1.0
- [5] TR 25.956 v.0.2.0
- [6] Increasing GSM Micro-cell capacity, Telstra, EDCR0105, 4 June 97
- [7] GSM 11.26
- [8] R/R TI NT 060, Base Station Remotisers for E-TACS and GSM, outdoor and indoor application, Telecom Italia Mobile, April 1999
R/R TI NT 091, Base Station Remotisers for E-TACS and GSM, indoor application, Telecom Italia Mobile, January 2000

Preparato da - Prepared by Core research	Codice - Code. 14000500	Pagina - Page 1 (8)
Responsabile Documento / Approvazione - Doc respons / Approved	Data - Date 04/05/2001	File WDS report.doc

Technical Annex to R4-010668

WDS Test results example

This document is provided as a technical example of some test results on important performance parameters for a practical WDS.

It is meant to be used for reference only and it doesn't constitute in any way a technical specification of whatsoever nature.

Related documents:

R4-10559, Technical justification and overall advantages for UTRA Wideband Distribution Subsystems, TSG-RAN Working Group 4 Meeting #17, 21 – 25 May 2001, Goteborg, Sweden

Preparato da - Prepared by Core research	Codice - Code. 14000500	Pagina - Page 2 (8)
Responsabile Documento / Approvazione - Doc respons / Approved	Data - Date 04/05/2001	File WDS report.doc

1 BLOCK DIAGRAMS

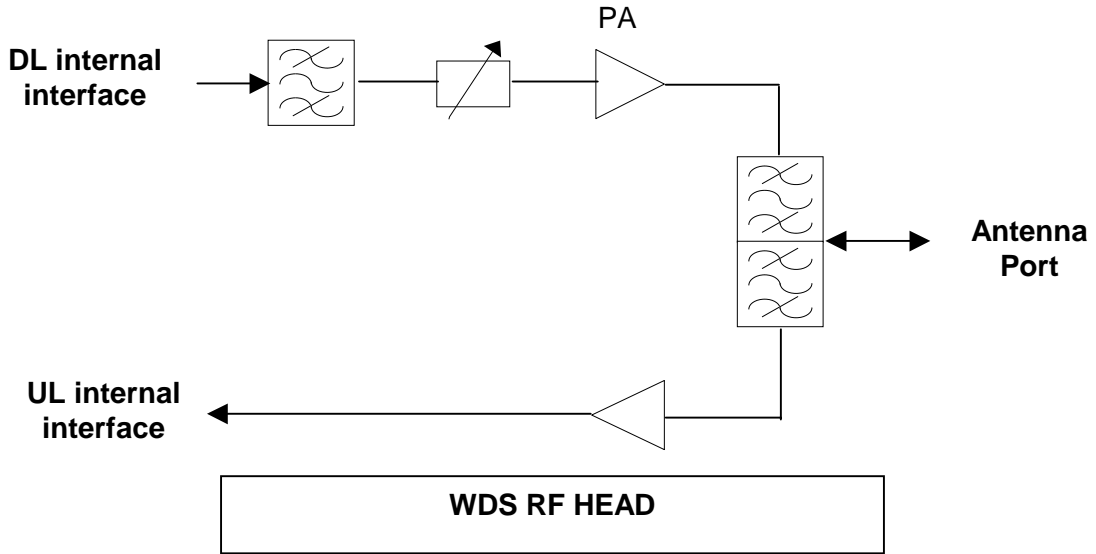

Figure 1

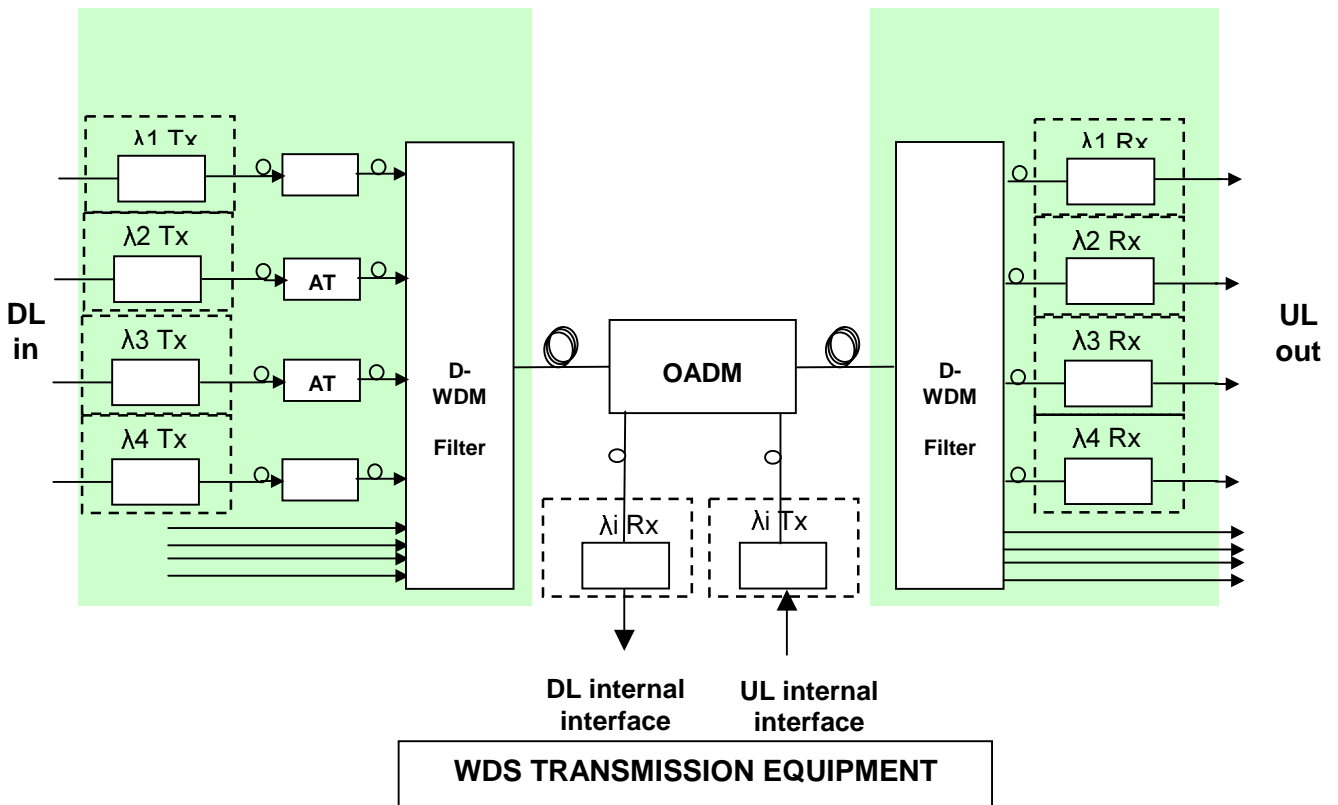

Figure 2

Preparato da - Prepared by Core research	Codice - Code. 14000500	Pagina - Page 3 (8)
Responsabile Documento / Approvazione - Doc respons / Approved	Data - Date 04/05/2001	File WDS report.doc

Preparato da - Prepared by Core research	Codice - Code. 14000500	Pagina - Page 4 (8)
Responsabile Documento / Approvazione - Doc respons / Approved	Data - Date 04/05/2001	File WDS report.doc

2 WDS RF TESTING

2.1 DOWNLINK PERFORMANCE

Following measurements were made between RF antenna port at RF Head and 'DL in' connector at HUB site transmission equipment.

Performance	Results	Unit	Test conditions
Link Gain	48.0 ±0.8	[dB]	
OIP3	50.5	[dBm]	Pout=20.6dBm\carrier F1=2110MHz F2=2120MHz IM3 at 2130MHz
OIP3	51.2	[dBm]	Pout=30.3dBm/carrier F1=2110MHz F2=2120MHz IM3 at 2130MHz
P1dB	41.4	[dBm]	F=2110MHz
Wideband Output Noise	-96.6	[dBm/Hz]	F=2110MHz
Wideband Output Noise	-95.7	[dBm/Hz]	F=2170MHz
W-CDMA output power with one carrier	32*	[dBm]	Test Model 1 (64) ACLR = -45.2 @ 5MHz offset ACLR = -56.3 @ 10MHz offset
W-CDMA output power with two carriers	25.4	[dBm]	Test Model 1 (64) ACLR = -45.4 @ 5MHz offset ACLR = -51.2 @ 10MHz offset

Note *: output power was purposely increased to the very limit for ACLR, in order to stress any critical situation with heavy loading.

Preparato da - Prepared by Core research	Codice - Code. 14000500	Pagina - Page 5 (8)
Responsabile Documento / Approvazione - Doc respons / Approved	Data - Date 04/05/2001	File WDS report.doc

2.2 UPLINK PERFORMANCE

Following measurements were made between RF antenna port at RF Head and 'UL out' connector at HUB site transmission equipment.

Performance	Results	Unit	Test Conditions
Link Gain	43.5±0.5	[dB]	
OIP3	28	[dBm]	Pout=-7.7dBm/carrier F1=1940MHz F2=1950MHz IM3 at 1960MHz
P1dB(in)	-25.3	[dBm]	F=1950MHz
P1dB(out)	18.2	[dBm]	F=1950MHz
Wideband Output Noise	-124.6	[dBm/Hz]	F=1950MHz G=43.8dB
Noise Figure	5.6	[dB]	
Wideband Output Noise	-124.1	[dBm/Hz]	F2=1980MHz G=43.1dB
Noise Figure	6.8	[dB]	
Wideband Output Noise	-124.6	[dBm/Hz]	F3=1920MHz G=43.8dB
Noise Figure	5.6	[dB]	

Preparato da - Prepared by Core research	Codice - Code. 14000500	Pagina - Page 6 (8)
Responsabile Documento / Approvazione - Doc respons / Approved	Data - Date 04/05/2001	File WDS report.doc

3 PLOTS

3.1 **WDS WCDMA TRANSMIT LINEARITY**

Following plots were taken while measuring WDS performance between RF antenna port at RF Head and 'DL in' connector at HUB site transmission equipment, in order to assess available linearity.

The WDS DL WCDMA output power and ACLR with one and two RF carriers was measured using test set up as described below, under 3GPP Test model 1 (64 data channel).

Overall insertion loss between WDS Antenna port and WCDMA signal analyser was 21.4 dB, that must be added to following measurement results.

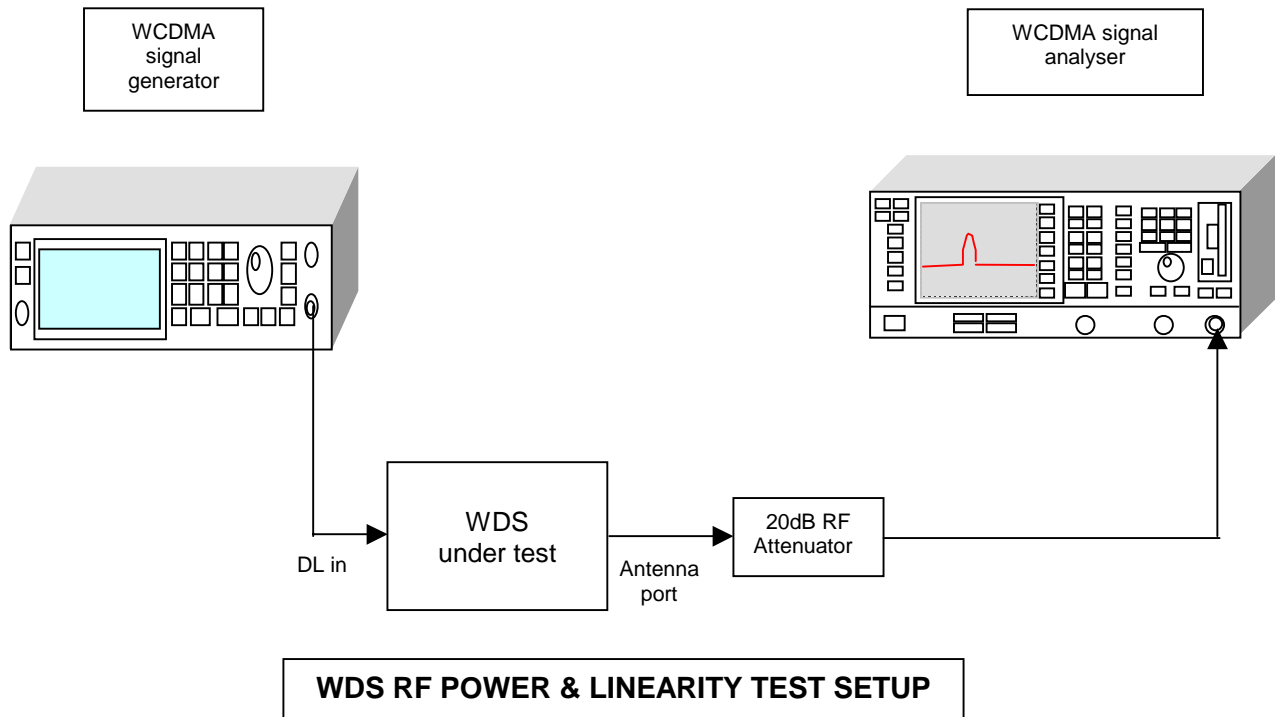
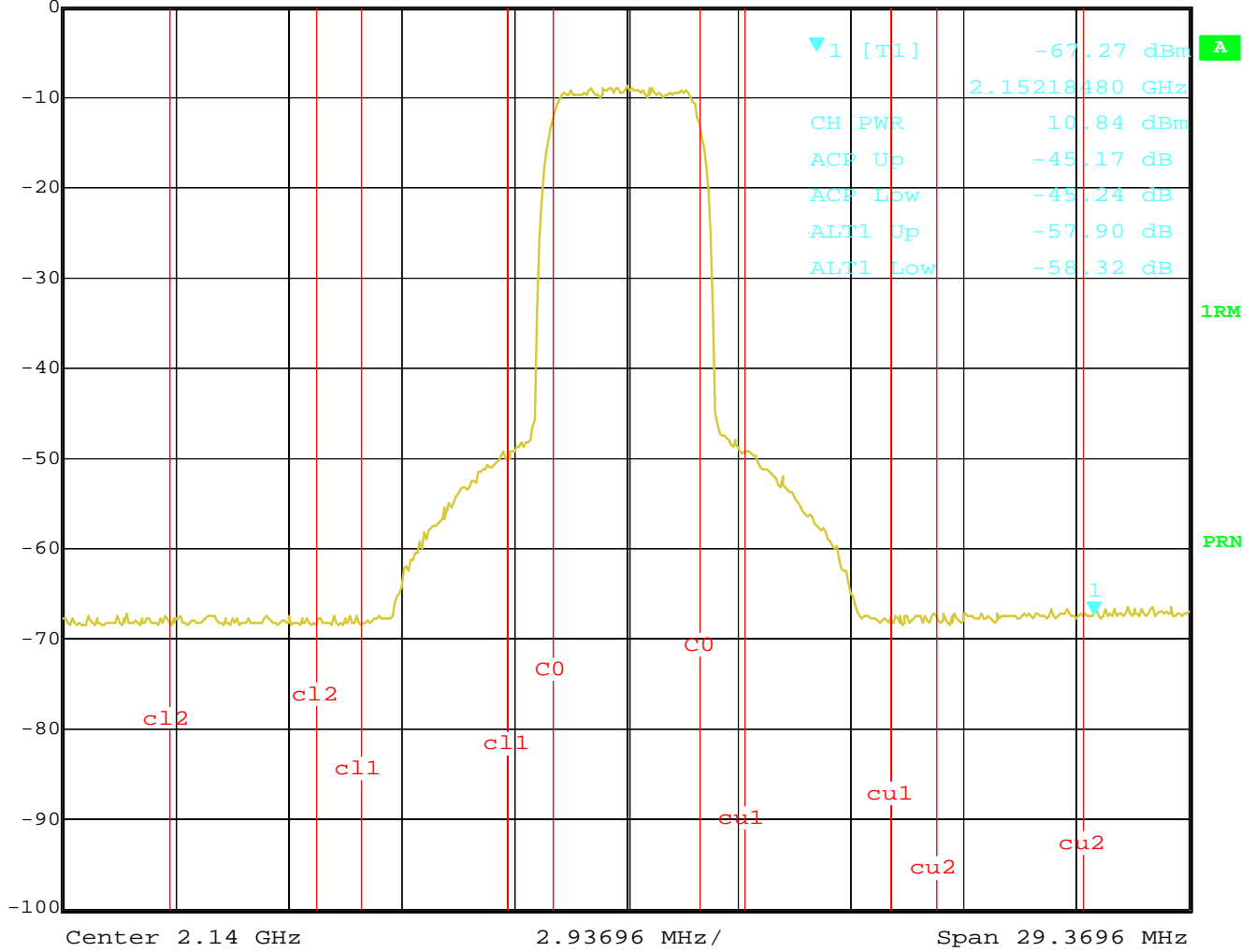

Figure 3

Preparato da - Prepared by Core research	Codice - Code. 14000500	Pagina - Page 7 (8)
Responsabile Documento / Approvazione - Doc respons / Approved	Data - Date 04/05/2001	File WDS report.doc



Marker 1 [T1] RBW 30 kHz RF Att 30 dB
 Ref Lvl -67.27 dBm VBW 300 kHz
 0 dBm 2.15218480 GHz SWT 2 s Unit dBm



Date: 2.MAY.2001 15:41:02

WDS RF OUTPUT POWER & ACLR, 1 RF CARRIER
P = 32dBm (1.66 Watt)

Figure 4

