

## Presentation of Specification to TSG or WG

---

<b>Presentation to:</b>	<b>TSG-RAN Meeting #12</b>
<b>Agenda item:</b>	<b>AH26: Tx Diversity</b>
<b>Document for presentation:</b>	<b>TR 25.869 Version 0.1.0</b>
<b>Presented for:</b>	<b>Approval</b>

---

### Abstract of document:

This technical report is for the Release 5 work item "Tx diversity solutions for multiple antennas". It consists of 4 Tx diversity concept and 1 pilot scheme for multiple transmit antennas solution. First, "Description of the eigen beamformer concept" is included. Second, "Basis selection scheme for >2 Tx antennas" is included. Third, "New CPICH Transmission scheme for >2 Tx antennas" included. Forth, "Tx diversity scheme with beamforming feature". Last, "Closed loop transmit diversity mode 2 with reduced status for 4 elements" is included. For each work task, there are several sections for background and introduction, description of studied concepts, performance, impacts to the UE and UTRAN implementation, impacts to physical layer operation, backwards compatibility to Release-4 and conclusion according to the specification of >2 Tx diversity. In this paper, not yet we introduce conclusion and a part of section leave <t,b,d> for future description according to the results of technical discussion.

---

### Changes since last presentation to TSG-RAN Meeting #11:

This TR is first version (V0.1.0) of RAN WG1 report on Tx diversity solutions for multiple antennas (Release 5). The following items is included:

5. Descriptions of studied concepts
  - 5.1 Description of the eigenbeamformer concept
  - 5.2 Basis selection scheme for >2 Tx antennas
  - 5.3 New CPICH Transmission scheme for >2 Tx antennas
  - 5.4 Tx diversity scheme with beamforming feature
  - 5.5 Closed loop transmit diversity mode 2 with reduced states for 4 elements
6. Performance
  - 6.1 Link level simulation assumptions
  - 6.2 Link level simulation results
  - 6.3 System level evaluation
7. Impacts to UE and UTRAN implementation
8. Impacts to physical layer operation
9. Backward compatibility to Release-99

Not yet filled the last conclusion section, which will be described followed by WG discussion.

---

### Outstanding Issues:

None

---

### Contentious Issues:

None

# 3G TR25.869 V0.1.0(2001-05)

---

*Technical Report*

TSG-RAN Working Group1 meeting#20

TSG R1-01-0670

Busan, Korea , 21<sup>th</sup> May – 25<sup>th</sup> May 2001

Agenda Item: Adhoc 26. Tx Diversity (R5)

Source: Editor

**3rd Generation Partnership Project;  
Technical Specification Group Radio Access Network;  
RAN WG1 report on Tx diversity solutions for multiple  
antennas  
(Release 5)**

---



The present document has been developed within the 3<sup>rd</sup> Generation Partnership Project (3GPP™) and may be further elaborated for the purposes of 3GPP

The present document has not been subject to any approval process by the 3GPP Organisational Partners and shall not be implemented. This Specification is provided for future development work within 3GPP only. The Organisational Partners accept no liability for any use of this Specification Specifications and reports for implementation of the 3GPP™ system should be obtained via the 3GPP Organisational Partners' Publications Offices.

---

Keywords

---

<keyword[, keyword]>

**3GPP**

---

Postal address

---

3GPP support office address

---

650 Route des Lucioles - Sophia Antipolis  
Valbonne - FRANCE  
Tel.: +33 4 92 94 42 00 Fax: +33 4 93 65 47 16

---

Internet

<http://www.3gpp.org>

---

**Copyright Notification**

No part may be reproduced except as authorized by written permission.  
The copyright and the foregoing restriction extend to reproduction in all media.

© 2000, 3GPP Organizational Partners (ARIB, CWTS, ETSI, T1, TTA, TTC).  
All rights reserved.

# Contents

Foreword.....	7
1 Scope.....	8
2 References.....	8
3 Definitions, symbols and abbreviations.....	8
3.1 Definitions.....	8
3.2 Symbols.....	8
3.3 Abbreviations.....	9
4 Background and Introduction.....	9
5 Descriptions of studied concepts.....	9
5.1 Description of the eigenbeamformer concept.....	9
5.1.1 Calculation of the Dominant Eigenvectors.....	11
5.1.2 Long Term Feedback Scheme.....	11
5.1.3 Short Term Feedback Scheme.....	12
5.1.4 Format of Feedback Information.....	12
5.2 Basis selection scheme for > 2 Tx antennas.....	13
5.2.1 Tx antenna weights.....	13
5.2.2 Representation of weight vectors.....	14
5.2.3 Feedback protocol structure.....	14
5.3 New CPICH Transmission scheme for > 2 Tx antennas.....	14
5.3.1 CPICH Transmission Scheme.....	15
5.3.1.1 CPICH Transmission Scheme.....	15
5.3.1.2 Receiver Structure of CPICH.....	16
5.3.1.2.1 Receiver structure of 4-ant diversity UE.....	16
5.3.1.2.2 Receiver structure of 2-ant diversity UE.....	16
5.3.1.2.3 Summary of channel estimation outputs.....	17
5.3.2 Common Physical Channel Tx Scheme.....	17
5.3.2.1 Common Physical Channel Tx Scheme.....	17
5.3.2.2 Receiver Structure of Common Physical Channel Tx Scheme.....	18
5.3.3 Dedicated Physical Channel Tx Scheme.....	18
5.3.3.1 Dedicated Physical Channel Tx Scheme for 2-ant UE.....	18
5.3.3.2 Dedicated Physical Channel Transmission Scheme for 4-ant UE.....	19
6 Performance.....	21
6.1 Link level simulation assumptions.....	22
6.1.1 Regular simulation assumptions.....	22
6.1.2 Additional simulation assumptions for the eigenbeamformer.....	24
6.1.2.1 Channel model for correlated antennas.....	25
6.1.2.2 Parameters for micro and macro cell scenarios.....	25
6.1.3 Basis selection for > 2 Tx antennas.....	26
6.2 Link level simulation results.....	27
6.2.1 Link level simulation results of the eigenbeamformer.....	27
6.2.1.1 Uncorrelated case.....	27
6.2.1.2 Micro cell scenario.....	27
6.2.1.3 Macro cell scenario.....	28
6.3.1 Basis selection for > 2 Tx antennas.....	29
6.3 System level evaluation.....	33
7 Impacts to UE and UTRAN implementation.....	34
7.1 Impacts to UE implementation.....	34
7.1.1 General impacts to UE implementation.....	34
7.1.2 Complexity evaluation of the eigenbeamformer concept.....	34
7.1.3 Basis selection scheme for > 2 Tx antennas.....	35
7.2 Impacts to UTRAN implementation.....	36
7.2.1 General impacts to UTRAN implementation.....	36
7.2.2 Eigenbeamformer concept.....	36

8 Impacts to physical layer operation.....37

8.1 Definition of additional orthogonal pilot sequences..... 37

8.2 Eigenbeamformer concept..... 37

9 Backwards compatibility to Release-99 .....37

9.1 Eigenbeamformer concept..... 37

9.2 Basis selection scheme for > 2 Tx antennas..... 37

9.3 New CPICH Transmission scheme for > 2 Tx antennas ..... 37

10 Conclusions .....37

History.....37

---

# Foreword

This Technical Specification has been produced by the 3<sup>rd</sup> Generation Partnership Project (3GPP).

The contents of the present document are subject to continuing work within the TSG and may change following formal TSG approval. Should the TSG modify the contents of the present document, it will be re-released by the TSG with an identifying change of release date and an increase in version number as follows:

Version x.y.z

where:

- x the first digit:
  - 1 presented to TSG for information;
  - 2 presented to TSG for approval;
  - 3 or greater indicates TSG approved document under change control.
- y the second digit is incremented for all changes of substance, i.e. technical enhancements, corrections, updates, etc.
- z the third digit is incremented when editorial only changes have been incorporated in the document.

# 1 Scope

## 2 References

The following documents contain provisions which, through reference in this text, constitute provisions of the present document.

?? References are either specific (identified by date of publication, edition number, version number, etc.) or non-specific.

?? For a specific reference, subsequent revisions do not apply.

?? For a non-specific reference, the latest version applies.

[<seq>]            <doctype><#>[ ([up to and including]{yyyy[-mm]}V<a[.b[.c]]>}{onwards})]: "<Title>".

- [1]                3G TS 25.211(V3.5.0): "Physical channels and mapping of transport channels onto physical channels (FDD)".
- [2]                3G TR 25.214 (V3.5.0): "Physical layer procedures (FDD)".
- [3]                3G TS 25.221 (V3.5.0): "Physical channels and mapping of transport channels onto physical channels (TDD)".
- [4]                3G TS 25.224 (V3.5.0): "Physical layer procedures (TDD)".
- [5]                Nokia. Recommended simulation parameters for Tx diversity simulations. TSG-R WG1 document, TSGR1#14(00)0867, July 4-7, 2000, Oulu, Finland, 5 pp.
- [6]                Siemens. Description of the eigenbeamformer concept (update) and performance evaluation. TSG-R WG 1 document, TSGR1#19(01)0203, February 27 – March 2, 2001, Las Vegas, USA.
- [7]                Siemens. Channel model for Tx diversity simulations using correlated antennas. TSG-R WG 1 document, TSGR1#15(00)1067, August 22-25, 2000, Berlin, Germany.
- [8]                Siemens. Simulation parameters for Tx diversity simulations using correlated antennas. TSG-R WG 1 document. TSGR1#16(00)1180, October 10-13, 2000, Pusan, Korea.
- [9]                R1-00-0882, "Preliminary version of algorithm and Simulation results for Tx Diversity with more than 2 Tx Antennas," TSG-RAN WG1#14, Oulu, Finland, July 2000

## 3 Definitions, symbols and abbreviations

### 3.1 Definitions

For the purposes of the present document, the [following] terms and definitions [given in ... and the following] apply.

*Definition format*

**<defined term>**: <definition>.

**example**: text used to clarify abstract rules by applying them literally.

### 3.2 Symbols

For the purposes of the present document, the following symbols apply:

*Symbol format*



<symbol>      <Explanation>

### 3.3 Abbreviations

For the purposes of the present document, the following abbreviations apply:

*Abbreviation format*

<ACRONYM> <Explanation>

---

## 4 Background and Introduction

The standardization of 3<sup>rd</sup> generation WCDMA system has been going on in 3<sup>rd</sup> Generation Partnership Project (3GPP) since the end of 1998. The 3G systems bring a promise of much higher data rates and enhanced services when compared to 2G systems. As many of the proposed services, like wireless web browsing, are expected to be downlink-intensive it was recognized from the very beginning that improvement of downlink capacity is one of the main challenges.

Performance of radio system depends on various issues but one important factor is the available diversity (time, frequency, multipath etc.). Due to wide bandwidth WCDMA systems are especially effective in exploiting the multipath diversity existing in time dispersive radio environments. If little or no multipath diversity is available the performance can degrade quite considerably. One way of improving the situation is to utilize 2 or more receive and/or transmit antennas that effectively speaking introduce additional radio paths and thereby increase the available diversity. As receiver antenna diversity is implementation wise challenging especially for low cost terminals a lot of attention have been paid to various transmit diversity solutions to be employed on radio access network side.

During 1999 a great deal of effort was put on defining transmit diversity solutions for Rel.-99 of 3GPP WCDMA specifications. As a result two open loop techniques, Space Time Transmit Diversity (STTD) and Time Switched Transmit Diversity (TSTD), and closed loop solution based on Transmit Adaptive Array (Tx AA) concept with two different modes were standardized for FDD [1,2]. For TDD, TSTD and Block STTD open loop methods can be used on SCH and P-CCPCH, respectively, and closed loop methods on DPCH [3, 4]. All the Rel.-99 Tx diversity methods assume two transmit antennas.

Already during 1999 it was recognized that further performance improvements could be possible by increasing the number of transmit antennas. Yet, it was agreed that Tx diversity for more than 2 antennas will be studied for possible inclusion to Rel.-5 of 3GPP specifications. The following chapters describe the proposed concepts, present the performance results, consider the impacts on UE and UTRAN implementation, and physical layer operation, and, finally, present issues related to backwards compatibility to Rel.-99 followed by conclusions.

---

## 5 Descriptions of studied concepts

### 5.1 Description of the eigenbeamformer concept

With increasing the number of antenna elements by using an extension of the Release-99 TxD modes, the amount of necessary feedback is increased. When keeping the uplink bandwidth the same the antenna weights cannot be adjusted fast enough to account for fast fading. Hence, for higher velocities of the UE the gain due to the additional antenna elements is low.

However there are ways to reduce the necessary feedback bandwidth if the antenna channel paths are correlated. One possible concept to achieve a lower feedback bandwidth is the eigenbeamformer concept which takes advantage of the correlated antenna paths. The general idea behind the eigenbeamformer is a decorrelation of the antenna signal paths to achieve a reduction in dimension of the spatial space. This enables subsequent short term processing at the UE to sufficiently mitigate fast fading.

This decorrelation is performed by exploiting the long term properties of the propagation paths based on an eigenanalysis of its long term spatial covariance matrix. The eigenvectors (in the sequel also called eigenbeams) with the largest eigenvalues (largest average UE receive power) are determined and fed back step by step to the Node B. This

process takes place on the same time scale as the physical UE movement. Accordingly, the required operations in the UE as well as required feedback bits are distributed over a very large number of slots.

In addition, a short term selection between the eigenbeams is carried out at the UE to account for fast fading. This information is fed back to the Node B on (almost) every slot.

By this technique it is possible to address a larger number of antenna elements providing large beamforming gains at higher velocities.

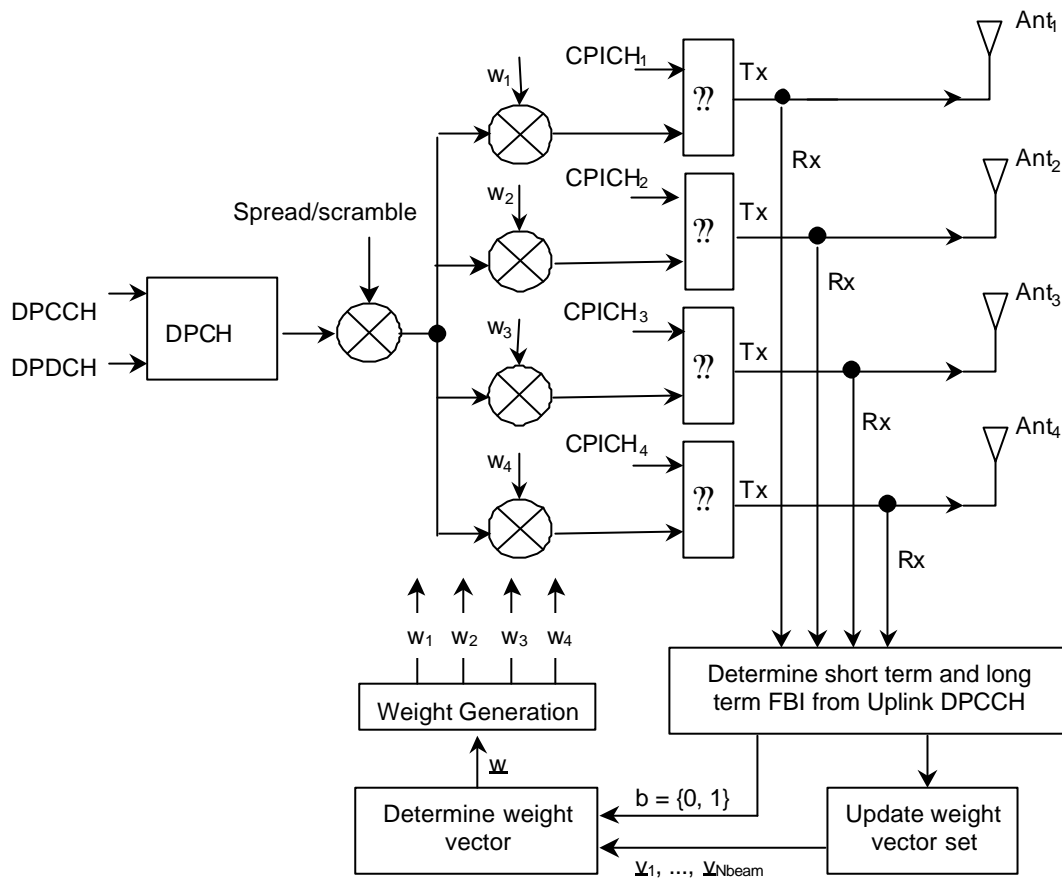

**Figure 1. Generic Downlink transmitter at the Node B with M = 4 antenna elements**

Figure 1 and Figure 2 show the generic architecture of the eigenbeamformer concept at the Node B and the UE. In the following sections the focus is on a system with M = 4 antenna elements and Nbeam = 2 or 4 eigenvectors. However the eigenbeamformer is easily extendable to more antenna elements.

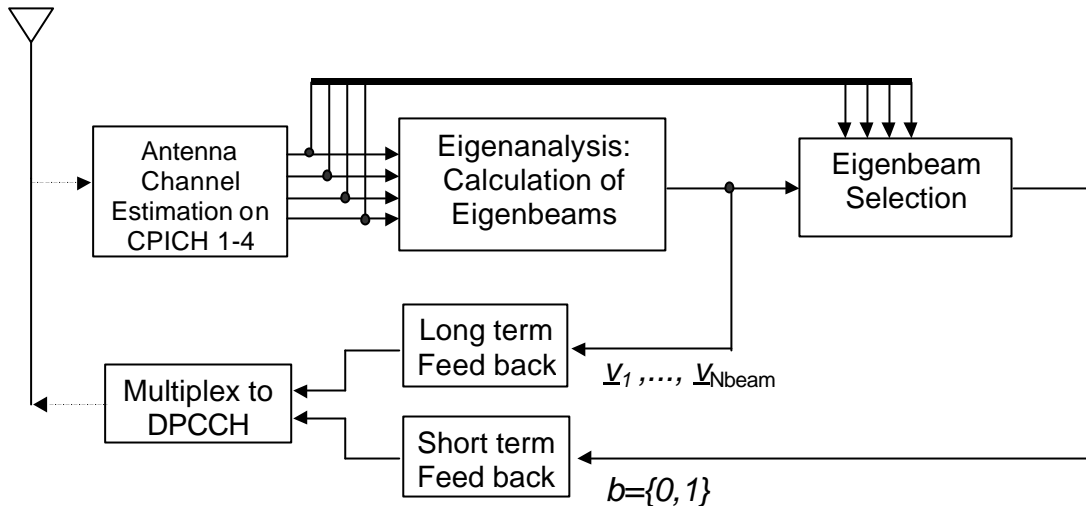

Figure 2. Generic eigenbeamformer structure at the UE for M = 4

### 5.1.1 Calculation of the Dominant Eigenvectors

Using orthogonal pilot sequences transmitted from the Node B antenna elements, the UE estimates the short term spatial covariance matrix averaged over the temporal taps of the channel.

$$R_{ST} = \sum_{n=1}^N h_n h_n^H \tag{1}$$

The column vector  $h_n = [h_{n1}, h_{n2}, \dots, h_{nM}]^T$  denotes the channel vector of the n-th temporal tap. The number of taps is denoted by N; M = 4 antenna elements are assumed. The long term spatial covariance matrix is obtained by averaging the short term matrix using a forgetting factor  $\alpha$ .

$$R_{LT}(i) = \alpha R_{LT}(i-1) + (1-\alpha) R_{ST}(i) \tag{2}$$

The symbol i denotes the time index. It is sufficient to perform an update once every frame or even in larger intervals.

Decorrelation in space is achieved by an eigenanalysis of the long term spatial covariance matrix according to

$$R_{LT} V = V T \tag{3}$$

The eigenvectors (eigenbeams) to be found are columns of  $V$ . Since the matrix  $T$  is diagonal by definition, transmission on different eigenbeams leads to uncorrelated fast fading. The diagonal entries indicate the long term UE received power of each beam.

Note that the eigenbeamformer automatically adjusts to various propagation environments (spatially correlated or uncorrelated). If the channel is spatially correlated, the channel can accurately be described by a small number of eigenbeams. If, on the other hand, the channel has a spatial correlation of zero, no long term spatial channel information can be exploited and each eigenvector addresses only one antenna element.

### 5.1.2 Long Term Feedback Scheme

From the set of M = 4 eigenbeams in  $V$ , Nbeam vectors with the largest eigenvalues will be chosen to be transmitted in the long term feedback.

Each weight vector is a vector of complex numbers. The size of this vector equals the number of antenna elements (M = 4). Each complex vector element is quantized by a number of bits. There are different ways for quantization. For example, the absolute value and the phase can be quantized with 3 and 5 bits respectively. Hereby, the amount of bits

can be reduced if the phase of the first vector element is set to zero. Thus, for the transmission of one eigenbeam  $4 \times 3 \times 3 = 27$  bits are necessary.

This number applies for the direct feedback of the eigenbeams from the UE to the Node B. Also methods with progressive refinement could be used that transmit only the difference to the previously sent vector. This could reduce the subsequent update period and an increased quantization / resolution is possible.

More advanced long term feedback concepts could be used which require less feedback bits.

The implementation of mechanisms to protect the long term bits from bit errors are for further study.

### 5.1.3 Short Term Feedback Scheme

#### Scheme 1: Eigenbeamformer using selection

A short term estimate of the UE received power is performed for each eigenbeam by calculating

$$P_m = \mathbf{v}_m^H \mathbf{R}_{ST} \mathbf{v}_m = \sum_{n=1}^N |\mathbf{v}_m^T \mathbf{h}_n|^2 \quad (4)$$

where  $m$  characterizes the eigenbeam. The eigenbeam that results in the maximum value for the received power  $P_m$  is selected and signalled to the Node B.

For two (four) eigenbeams 1 (2) bit(s) is (are) transmitted to indicate the selection.

The overlaying long term processing makes it possible to switch between eigenbeams instead of antenna elements. An increasing number of antenna elements can be addressed without reducing the UE velocity threshold.

Note that the pilot symbols of the DPCCH may be used for eigenbeam verification similar to the closed loop modes in Release-99.

#### Scheme 2: Eigenbeamformer using weighted combining

A short term estimate of the UE received power is performed for each weight vector by calculating

$$P_m = \mathbf{w}_m^H \mathbf{R}_{ST} \mathbf{w}_m = \sum_{n=1}^N |\mathbf{w}_m^T \mathbf{h}_n|^2 \quad (5)$$

where  $\mathbf{w}_m = \frac{\sqrt{\lambda_2}}{\sqrt{\lambda_1} + \sqrt{\lambda_2}} \mathbf{v}_1 + \frac{\sqrt{\lambda_1}}{\sqrt{\lambda_1} + \sqrt{\lambda_2}} \mathbf{v}_2 \exp(j\theta_m)$ ,  $\theta_m \in \{\pi/4, 3\pi/4, 5\pi/4, 7\pi/4\}$ .  $m$  characterizes the degree of the combining phase. Where  $\lambda_1$  and  $\lambda_2$  is first and second largest eigenvalue of long term covariance matrix,  $\mathbf{R}_{LT}$ , respectively and  $\theta_m$  is a short term parameter. The weight vector that results in the maximum value for the received power  $P_m$  is selected and signalled to the Node B.

For two (four) eigenbeams 2 (4) bits are transmitted to indicate the selection and progressive refine is applied to transmit each bit. The overlaying long term processing makes it possible to co-phase combine two(four) eigenbeams instead of antenna elements.

An increasing number of antenna elements can be addressed without reducing the UE velocity threshold. Note that the pilot symbols of the DPCCH may be used for eigenbeam verification similar to the closed loop modes in Release-99.

### 5.1.4 Format of Feedback Information

The feedback rate for the eigenbeamformer is kept at the same rate as in Release-99 and is 1500 bit/s. The long term information bits (for feedback of eigenbeams) and the short term information bits (for feedback of eigenbeam selection) are multiplexed. The following frame format for the feedback information bits is proposed:

**Table 1: Multiplexing of long term / short term feedback information**

Slot #	1	2	3	4	5	6	7	8	9	10	11	12	13	14	15
short term FB bits	1	1	1	1	1	1	1	1	1	1	1	1	1	1	0
long term FB bits	0	0	0	0	0	0	0	0	0	0	0	0	0	0	1

In this multiplexing format the transmission of two eigenbeams would take  $2 \times 27 = 54$  frames or 540 ms (see section 5.1.2). The eigenbeam selection of the previous slot is applied in the slots where no short term feedback information is received by the Node B (slot #15).

This format is confined to one radio frame. Thus, no counting over frame boundaries is necessary.

In a later extension with more than 4 antenna elements other formats could be used, e.g. using 3 long term feedback bits within one frame. This is for further study.

**Table 2: Multiplexing format of long term / short term information for more than 4 antenna elements**

Slot #	1	2	3	4	5	6	7	8	9	10	11	12	13	14	15
short term FB bits	1	1	1	1	0	1	1	1	1	0	1	1	1	1	0
long term FB bits	0	0	0	0	1	0	0	0	0	1	0	0	0	0	1

Since no long term channel information is available at the Node B for a user at the start of transmission, initial weight vectors may, for instance, address only one of the antenna elements, e.g.,

$$\mathbf{v}_1 = \begin{bmatrix} ? \\ ? \\ ? \\ ? \\ ? \\ ? \\ ? \\ ? \end{bmatrix}, \quad \mathbf{v}_2 = \begin{bmatrix} ? \\ ? \\ ? \\ ? \\ ? \\ ? \\ ? \\ ? \end{bmatrix}, \quad \text{for } M = 4 \text{ antenna elements.}$$

## 5.2 Basis selection scheme for > 2 Tx antennas

### 5.2.1 Tx antenna weights

In closed loop Tx diversity systems, the weights of transmit antennas are determined at a mobile station and fed back to the base station. These weights should result in as high SNR as possible at the mobile. The set of these weights may be viewed as a vector  $\underline{w} = [w_1 \ w_2 \ \dots \ w_i \ \dots \ w_M]^T$ , where  $w_i$  is a complex weight associated with the  $i$ th Tx antenna. For the maximum SNR at the mobile, the weights should maximize  $P$  below:

$$P = \underline{w}^H H^H H \underline{w}, \tag{5}$$

when  $H = [\underline{h}_1 \ \underline{h}_2 \ \dots \ \underline{h}_i \ \dots \ \underline{h}_M]$  and  $M$  is the number of Tx antennas. The column vector  $\underline{h}_i$  represents an estimated channel impulse response for the  $i$ th Tx antenna, and its vector length equals to the number of paths. The weight vector  $\underline{w}$  information is periodically fed back to the base station. Note that the amount of feedback information and the implementation complexity increase with the number of Tx antennas. The efficient representation of a weight vector is desired to reduce the amount of feedback data and the implementation complexity. Furthermore, backward compatibility is desirable.

A weight vector with  $M$  elements may be represented as a linear sum of basis vectors, which span an  $M$ -dimensional space. Examples of basis vectors for 2-, 3-, 4-dimensional spaces are shown in Appendix A of [9]. Let's assume for explanation that 4 Tx antennas are used for Tx diversity. The optimal weight vector  $\underline{w}_{opt}$  for this system has 4 elements and may be represented as a linear sum of four basis vectors,  $\underline{B}_1, \underline{B}_2, \underline{B}_3, \underline{B}_4$ , as follows:

$$\underline{w}_{opt} = c_1 \underline{B}_1 + c_2 \underline{B}_2 + c_3 \underline{B}_3 + c_4 \underline{B}_4 \tag{6}$$

where  $c_1, \dots, c_4$  are complex coefficients associated with corresponding vectors. Assuming that  $|c_1| > |c_2| > |c_3| > |c_4|$ ,  $\underline{w}_{opt}$  may be approximated as

$$\underline{w}_{app\_1} = c_1 \underline{B}_1, \quad (7.a)$$

$$\underline{w}_{app\_2} = c_1 \underline{B}_1 + c_2 \underline{B}_2, \quad (7.b)$$

$$\underline{w}_{app\_3} = c_1 \underline{B}_1 + c_2 \underline{B}_2 + c_3 \underline{B}_3, \quad (7.c)$$

These vectors  $\underline{w}_{app\_1}$ ,  $\underline{w}_{app\_2}$ ,  $\underline{w}_{app\_3}$ , may be viewed as the projections of  $\underline{w}_{opt}$  into 1-dim, 2-dim, and 3-dim subspaces.  $\underline{w}_{app\_3}$  is more accurate representation of  $\underline{w}_{opt}$  than  $\underline{w}_{app\_1}$  and  $\underline{w}_{app\_2}$ .

## 5.2.2 Representation of weight vectors

The conventional representation of the vector  $\underline{w}_{opt}$  may require  $(M-1) \cdot N_c$  bits, where  $N_c$  bits are required to represent each element of  $\underline{w}_{opt}$ . This representation indicates that the transmission of  $(M-1) \cdot N_c$  bits at 1500Hz is required to support Tx diversity with  $M$  Tx antennas. The reason for  $(M-1) \cdot N_c$  not  $M \cdot N_c$  is that one of  $M$  Tx antennas may be viewed as reference and the relative weights for other antennas are required. To reduce the required number of bits, it is proposed to feedback information on the approximated vector, instead of  $\underline{w}_{opt}$ . The representation of the approximated vector includes the specification of basis vectors and associated coefficients. When there are  $M$  Tx antennas and the approximation is made in a  $S$ -dimensional subspace, there are  ${}^M C_S$  combinations for selecting  $S$  basis vectors among  $M$  vectors and the required number of bit to specify the basis vector combination is  $\lceil \log_2 ({}^M C_S) \rceil$ .

## 5.2.3 Feedback protocol structure

In the simulation, the two cases for antenna selection is considered: **Case 1**) 2 antenna selection ( $M=4, S=2$ ), it noted as 4C2 and **Case 2**) 3 antenna selection ( $M=4, S=3$ ), it noted as 4C3. In both cases, 2bit representation for each element (phase only) is used ( $N_c = 2$ ). The required number of feedback information per signalling word is: **Case 1**) 5 bits, and **Case 2**) 6bits. For detail simulation scheme, section 6.2.1 can be referred. The considered frame format of feedback information is:

(Case 1: 2 best selection among 4 basis and combine all 2 with received phase information)

Slot	1	2	3	4	5	6	7	8	9	10	11	12	13	14	15
Phase				P <sub>1</sub>	P <sub>2</sub>				P <sub>1</sub>	P <sub>2</sub>				P <sub>1</sub>	P <sub>2</sub>
Selection	S <sub>1</sub>	S <sub>2</sub>	S <sub>3</sub>			S <sub>1</sub>	S <sub>2</sub>	S <sub>3</sub>			S <sub>1</sub>	S <sub>2</sub>	S <sub>3</sub>		

S<sub>i</sub>: Antenna selection bits

P<sub>i</sub>: Phase difference with respect to the coefficient associated with the first basis vector

(Case 2 : 3 best selection among 4 basis and combine all 3 with received phase information)

Slot	1	2	3	4	5	6	7	8	9	10	11	12	13	14	15
Phase			P <sub>11</sub>	P <sub>12</sub>	P <sub>21</sub>	P <sub>22</sub>			P <sub>11</sub>	P <sub>12</sub>	P <sub>21</sub>	P <sub>22</sub>			P <sub>11</sub>
Selection	S <sub>1</sub>	S <sub>2</sub>					S <sub>1</sub>	S <sub>2</sub>					S <sub>1</sub>	S <sub>2</sub>	

S<sub>i</sub>: Antenna selection bits

P<sub>ij</sub>: Phase difference with respect to the coefficient associated with the first basis vector

## 5.3 New CPICH Transmission scheme for > 2 Tx antennas

In Release 99 specification, transmit diversity using 2 antennas is included. Currently, various transmit diversity schemes using 4 transmit antenna are considered for possible extension to Release 2000. However, the most important thing that should be solved first is the pilot reference channel for 4-antenna.

In this document, a new CPICH transmission scheme is propose for 4-antenna transmit diversity. The most important thing that should be kept in mind when proposing new CPICH transmission scheme for 4-antenna transmit diversity is the backward compatibility. Here, the backward compatibility means that the Release 99 UE should be able to

demodulate the whole physical channels (dedicated or common physical channel) without any change in receiver structure.

In section 5.3.1, the transmission scheme of CPICH for 4-antenna transmit diversity is described and the backward compatibility is proved. In section 5.3.2, corresponding common physical channel transmission scheme with 4 transmit antenna to satisfy the backward compatibility is proposed. And the corresponding transmission schemes of dedicated physical channel with 2-antenna and 4-antenna transmit diversity UE are described in section 5.3.3.

Let's distinguish UEs by their diversity mode as following.

2-ant diversity UE: UE in 2-antenna diversity mode (open/closed)

4-ant diversity UE: UE in 4-antenna diversity mode (open?/closed?)

## 5.3.1 CPICH Transmission Scheme

### 5.3.1.1 CPICH Transmission Scheme

If UTRAN supports 4 transmit diversity (open or closed loop) for dedicated channel to UE in the cell, then it should provide 3 additional diversity pilot channels as well as primary CPICH. However, since the CPICH is a common physical channel it also should be received by all UEs with different diversity mode, and thus one and only one CPICH transmission scheme should be used. Each UE should estimate the channel(s) as many as the number of transmit antenna, since each antenna has its own path. That is, common CPICH transmission scheme for 4 transmit antenna shall have the property that it must be recognised as one, two, or 4 pilot channels to 2-ant diversity UE and 4-ant diversity UE, respectively. Figure 3 shows the proposed CPICH transmission scheme for 4 transmit antenna which satisfies the property. The main characteristics of the proposed CPICH transmission scheme are:

- using two OVSF codes ( $C_{OVSF1}$  and  $C_{OVSF2}$ )
- same pilot pattern as Release 99' 2-ant CPICH (AA and A-A/ -AA)
- different control of pilot channel gain for 2-ant or 4-ant diversity reception
- backward compatible with Release 99
- reduce PAPR by distributing physical channels to 4 antenna

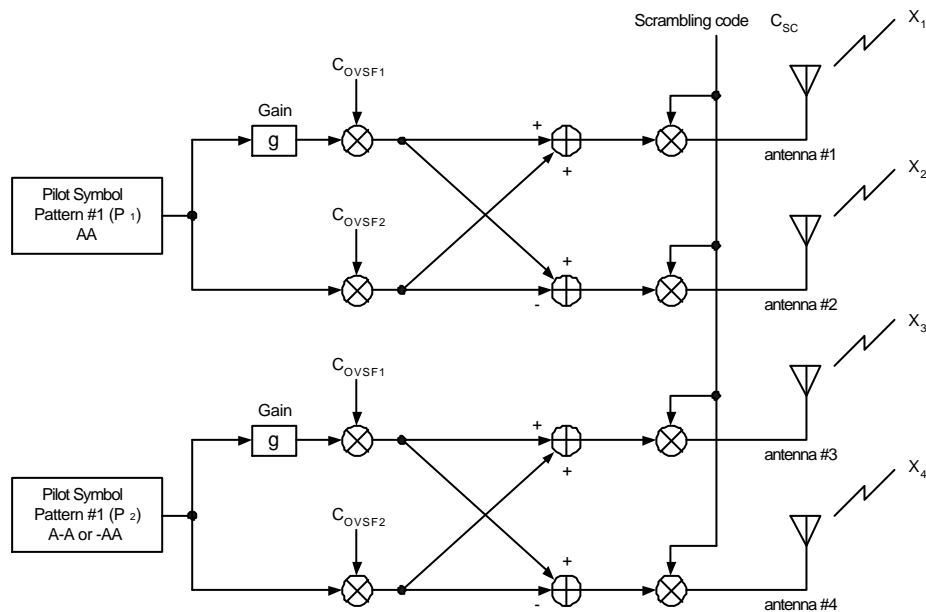

Figure 3. Proposed CPICH transmission scheme for 4 antenna transmit diversity

The CPICH signal from each antenna at the receiver side is given by the following equations. The timing index and background noise is ignored for simplicity.

$$\begin{aligned}
 X_1 &= P_1 (g C_{OVSF1} C_{OVSF2}) C_{SC} h_1 \\
 X_2 &= P_1 (g C_{OVSF1} C_{OVSF2}) C_{SC} h_2 \\
 X_3 &= P_2 (g C_{OVSF1} C_{OVSF2}) C_{SC} h_3 \\
 X_4 &= P_2 (g C_{OVSF1} C_{OVSF2}) C_{SC} h_4
 \end{aligned}
 \tag{8}$$

where  $P_1 (=AA)$  and  $P_2 (=A-A \text{ or } -AA)$  are the two pilot patterns defined for 2-ant CPICH in Release 99, and  $C_{SC}$  is the primary scrambling code. In Eq. ([9]),  $C_{OVSF1}$  and  $C_{OVSF2}$  are two OVSF codes where  $C_{OVSF1}$  is  $C_{ch,256,0}$  and  $C_{OVSF2}$  is one additional OVSF code.  $h_1, h_2, h_3, h_4$  are the channel coefficients for each antenna path. It is worth noting that the parameter  $g$  in Eq. ([9]) is the gain factor to discriminate the received pilot power for 2-ant and 4-ant diversity UE. By varying the gain  $g$ , the received pilot strength can be controlled to 2-ant diversity UE and 4-ant diversity UE. For 2-ant diversity UE only  $C_{OVSF1}$  is used and thus the second term in Eq. ([9]) is removed. On the other hand, for 4-ant diversity UE, both  $C_{OVSF1}$  and  $C_{OVSF2}$  will be used and it can discriminate 4 different antenna paths. Detail receiver structure of different diversity UE are described in next section.

### 5.3.1.2 Receiver Structure of CPICH

#### 5.3.1.2.1 Receiver structure of 4-ant diversity UE

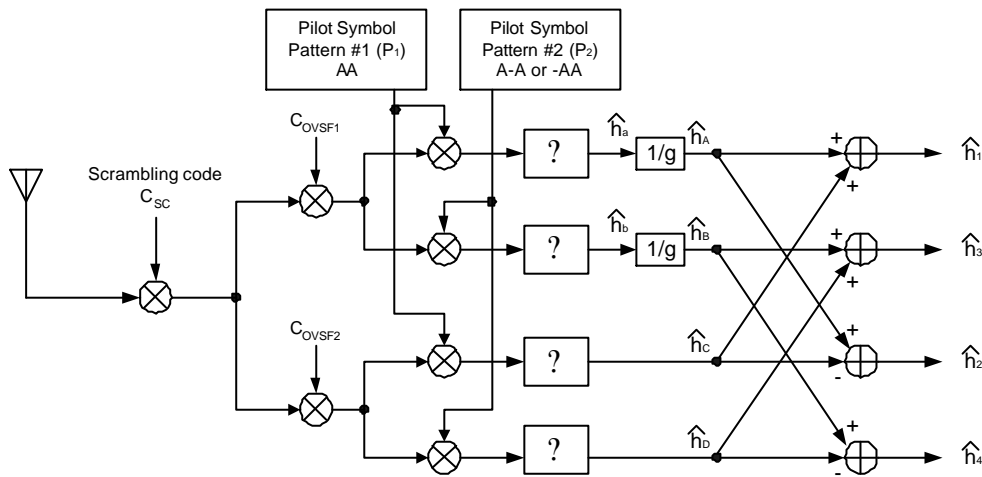

Figure 4. Receiver structure of 4-ant diversity UE

Figure 4 shows how the 4-ant diversity UE can receive and estimate the 4 channels. In Figure 4,  $\hat{h}_a, \hat{h}_b$  denote the channel estimation of  $h_a = g(h_1 + h_2)$ ,  $h_b = g(h_3 + h_4)$ , respectively. Similarly,  $\hat{h}_A, \hat{h}_B, \hat{h}_C, \hat{h}_D$  denote the estimation of  $h_A = h_1 + h_2$ ,  $h_B = h_3 + h_4$ ,  $h_C = h_1 - h_2$ ,  $h_D = h_3 - h_4$ , respectively. Note that these channel estimation pairs  $\{\hat{h}_a, \hat{h}_b\}$ ,  $\{\hat{h}_A, \hat{h}_B, \hat{h}_C, \hat{h}_D\}$ , or  $\{\hat{h}_1, \hat{h}_2, \hat{h}_3, \hat{h}_4\}$  can be used to compensate the common or dedicated physical channels.

#### 5.3.1.2.2 Receiver structure of 2-ant diversity UE

Figure 5 is the CPICH receiver structure of 2-ant diversity UE and it can also be used with the proposed CPICH transmission scheme without any change. Note that the channel estimation value with the receiver is exactly same as the output of the first branch output in Figure 4. That is,  $h_a = g(h_1 + h_2)$  and  $h_b = g(h_3 + h_4)$ . Consequently, there's no change required to Release 99 UE in terms of pilot channel estimation. The only difference is the effective channel through which the pilot signal is transmitted. In order for the proposed CPICH transmission scheme to become fully backward compatible, UTRAN also should modify the transmission structure of common/dedicated physical channels



with considering the channel estimation outputs of 2-ant diversity UE, and 4-ant diversity UE. The detail of the common/dedicated physical channel transmission structure is given in section 5.3.2 and 5.3.3.

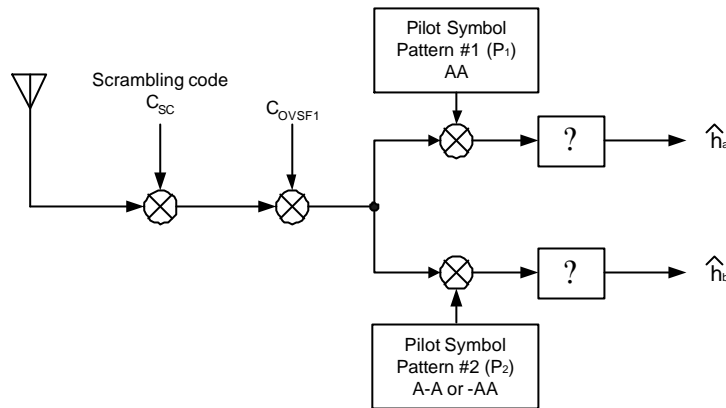

Figure 5. Receiver structure of 2-ant diversity UE

5.3.1.2.3 Summary of channel estimation outputs

Table 3. shows the summary of demodulation parameters and the channel estimation output according to the UE diversity mode. In Table 3 the related physical channel implies the physical channel that utilises the corresponding channel estimation output during demodulation. The main idea of the Table 3 is that the transmission structure of the related physical channel should be designed carefully with considering the corresponding channel estimation output.

Table 3. Summary of demodulation parameters and channel estimation output

Rx parameters UE mode	Pilot Channel				Related physical channel
	scrambling code	channelisation code	pilot pattern	channel estimation output	
2-ant diversity	$C_{SC}$	$C_{OVSF1} = C_{ch,256,0}$	AA A-A/-AA	$h_a ? g(h_1 ? h_2)$ $h_b ? g(h_3 ? h_4)$	Common CH Dedicated CH
4-ant diversity	$C_{SC}$	$C_{OVSF1} = C_{ch,256,0}$ $C_{OVSF2} = C_{ch,256,1}$	AA A-A/-AA	$h_a ? g(h_1 ? h_2)$ $h_b ? g(h_3 ? h_4)$	Common CH
				$h_1, h_2, h_3, h_4$	Dedicated CH

5.3.2 Common Physical Channel Tx Scheme

5.3.2.1 Common Physical Channel Tx Scheme

Common physical channel should be transmitted with one and only one transmission scheme. However, each UE should receive the common physical channel as their transmit diversity mode. Figure 6 is the proposed common physical channel transmission scheme where the original symbols ( $S_1, S_2$ ) are transmitted to antenna 1 and 2, while the STTD encoded symbols ( $-S_2^*, S_1^*$ ) are transmitted to antenna 3 and 4. Backward compatibility of this scheme can be easily proved and shown in section 5.3.2.2.

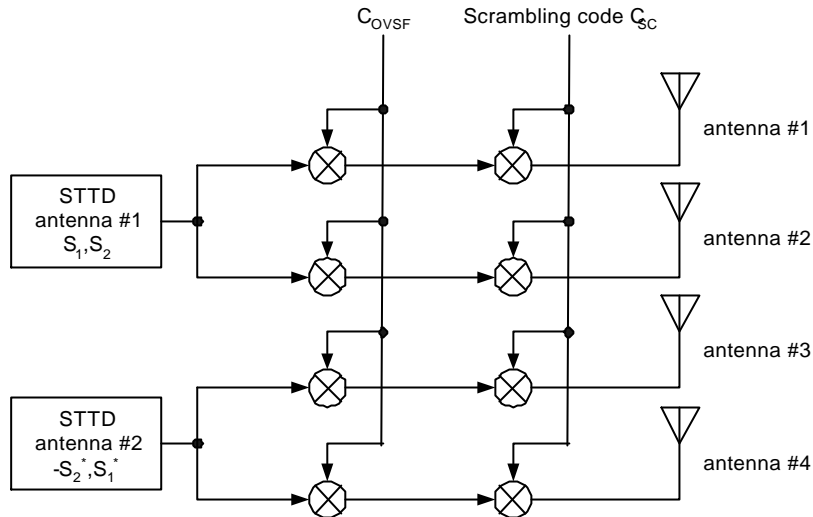

Figure 6. Common Physical Channel Transmission

### 5.3.2.2 Receiver Structure of Common Physical Channel Tx Scheme

If the common physical channel transmission scheme in Figure 6 is used, 2-ant and 4-ant diversity UE can receive the signals with the conventional STTD decoder as shown in Figure 7.

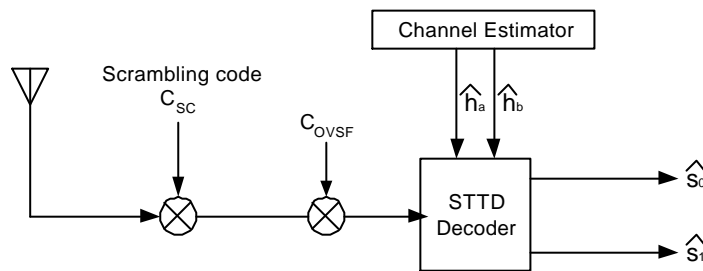

Figure 7. Receiver Structure for Common Physical Channel Transmission Scheme 1

The received signal after multiplication of OVSF in Figure 6 is given by

$$\begin{aligned}
 r_{t1} &= S_1(h_1 + h_2) + S_2^*(h_3 + h_4) + S_1 h_a + S_2^* h_b \\
 r_{t2} &= S_2(h_1 + h_2) + S_1^*(h_3 + h_4) + S_2 h_a + S_1^* h_b
 \end{aligned}
 \tag{9}$$

where  $t1, t2$  denote the time unit. Since the channel estimation provided by 2-antenna CPICH receiver are  $\hat{h}_a$  and  $\hat{h}_b$  (See Table 3), conventional STTD receiver can be used without any change.

### 5.3.3 Dedicated Physical Channel Tx Scheme

In case of a dedicated physical channel, transmission scheme should be different for each UE according to the diversity mode. However, the transmission scheme should be carefully designed with considering the available channel estimation output as given in Table 3.

#### 5.3.3.1 Dedicated Physical Channel Tx Scheme for 2-ant UE

For 2-ant diversity UE, the available channel estimation is  $h_a + g(h_1 + h_2)$ ,  $h_b + g(h_3 + h_4)$  (See Table 3). It means that the antenna 1 and antenna 2 should transmit one signal, and antenna 3 and antenna 4 should transmit the other signal. Based on the above constraint, Figure 8 and Figure 9 show the proposed transmission scheme for dedicated physical channel to 2-ant STTD and closed loop transmit diversity UE, respectively. By distributing 2-antenna signals

to 4-antenna, such situation that the power of 2-ant diversity UE's concentrate on two antenna can be avoided. Definitely, it reduces the PAPR (Peak to Average Power Ratio)

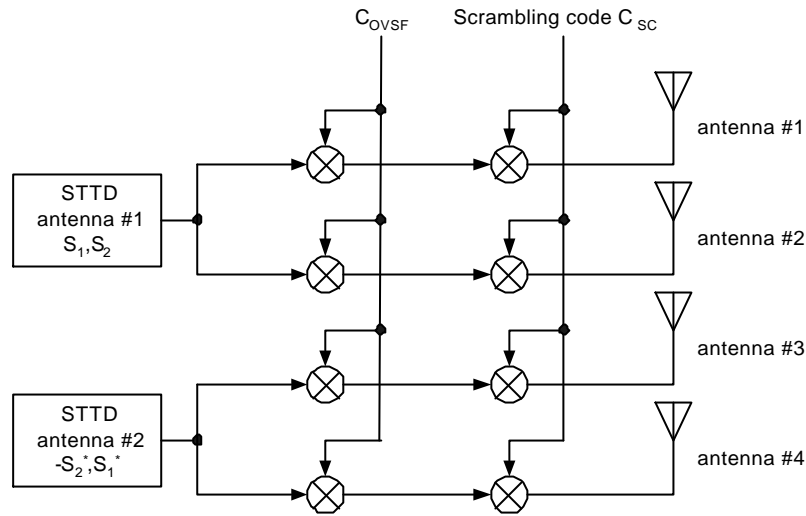

Figure 8. Dedicated physical channel transmission scheme for 2-ant STTD diversity UE

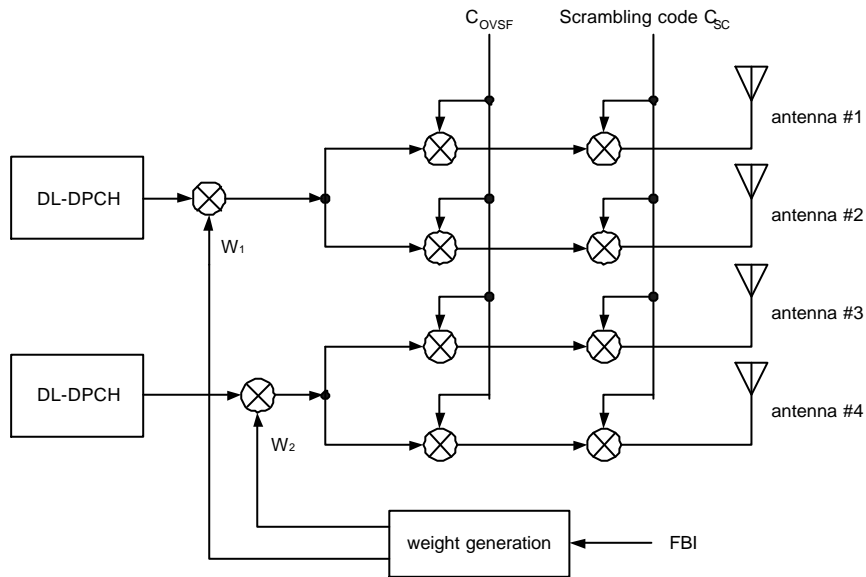

Figure 9. Dedicated physical channel transmission scheme for 2-ant closed loop transmit diversity UE

### 5.3.3.2 Dedicated Physical Channel Transmission Scheme for 4-ant UE

If a dedicated physical channel is transmitted to a 4-ant diversity UE, the transmission scheme should be designed with considering the available channel estimations output to the UE. With the proposed CPICH transmission scheme, the available channel estimation output of the 4-ant diversity UE are  $\hat{h}_1, \hat{h}_2, \hat{h}_3, \hat{h}_4$  (See Table 3). Currently, there is no accepted 4-antenna open/closed loop transmit diversity scheme but the proposed CPICH transmission scheme can be used with any kind of open/closed loop diversity proposal.

## 5.4. Tx diversity scheme with beamforming feature

It is desirable that the closed loop multiple antenna transmit diversity/beamforming scheme can support a variety of antenna configurations and beamforming algorithms. To achieve it efficiently, the higher layer signaling information about Tx antenna configurations of Node B to UE is necessary. As the spatial correlation largely depends on the Tx antenna configurations in most cases, it will greatly help UEs to determine how appropriately the diversity and beamforming be combined, e.g. the number of beams and the feedback frame format.

Spatial correlation property depends on both the transmit antenna configuration and the radio propagation environment. The latter is unpredictable and performance depends on how feedback scheme matches the channel. For example, in strong spatially correlated channels, frequent update of short-term diversity weights is not efficient. In spatially uncorrelated channels, feedback bits for long-term beamforming weights are useless. The former, selection of antenna configuration, is one of the design criteria for cellular operators. It is rather easy to control spatial correlation by choosing appropriate antenna configuration.

In theory, employing multiple transmit antenna elements can achieve both diversity gain and beamforming gain. If the antennas are placed far away from each other, maximum diversity gain can be achieved but, due to the grating lobe problem, the achievable beamforming gain is limited. On the other hand, if the inter-element spacing in the antenna array is small, maximum beamforming gain can be obtained but the diversity gain will be limited as signals from different antenna elements are highly correlated.

### 5.4.1. Description of our solution

According to the transmit antenna configuration of the Node B, UE calculate short-term diversity weights and long-term beamforming weights. The hierarchical weighting is defined as shown in Figure 10.

Consider an  $M$  sub-arrays configuration in which each sub-array consists of  $K=N/M$  elements. Firstly, UE finds an  $M$ -dimensional short-term diversity weight vector  $\underline{w}_D$ , which maximize

$$P_D \propto \underline{w}_D^H H_D^H H_D \underline{w}_D \quad (1)$$

with  $H_D = [\underline{h}_1, \underline{h}_{K?1}, \dots, \underline{h}_{(M?1)K?1}]$

where,  $\underline{h}_{(m?1)K?1}$  ( $m = 1 \dots M$ ) is the channel response vector, which represents the  $m$ -th sub-array.

Secondly, UE finds a  $K$ -dimensional beamforming weight vector  $\underline{w}_{B,m}$  for each sub-array which maximize

$$P_{B,m} \propto \underline{w}_{B,m}^H H_{B,m}^H H_{B,m} \underline{w}_{B,m} \quad (2)$$

with  $H_{B,m} = [\underline{h}_{(m?1)K?1}, \underline{h}_{(m?1)K?2}, \dots, \underline{h}_{(m?1)K?K}]$

where,  $\underline{h}_{(m?1)K?k}$  ( $k = 1 \dots K$ ) is the channel response vector of the  $k$ -th element in the  $m$ -th sub-array.

Then, short-term diversity weights  $D_{1,m}$  and long-term beamforming weights  $B_{m,k}$  for the hierarchical weighting are calculated from  $\underline{w}_D$  and  $\underline{w}_{B,m}$  as follows.

$$D_{1,m} = \frac{w_D(m)}{w_D(1)} \quad (m = 1 \dots M) \quad (3)$$

$$B_{m,k} = \frac{w_{B,m}(k)}{w_{B,m}(1)} \quad (m = 1 \dots M, k = 1 \dots K) \quad (4)$$

$\{D_{1,m}\}$  corresponds to the  $M$ -branch Tx diversity weights and  $\{B_{m,k}\}$  are beamformer weights for the  $m$ -th antenna group. The feedback frequency for  $\{D_{1,m}\}$  is much higher than that for  $\{B_{m,k}\}$  to suit for fast fading environment.

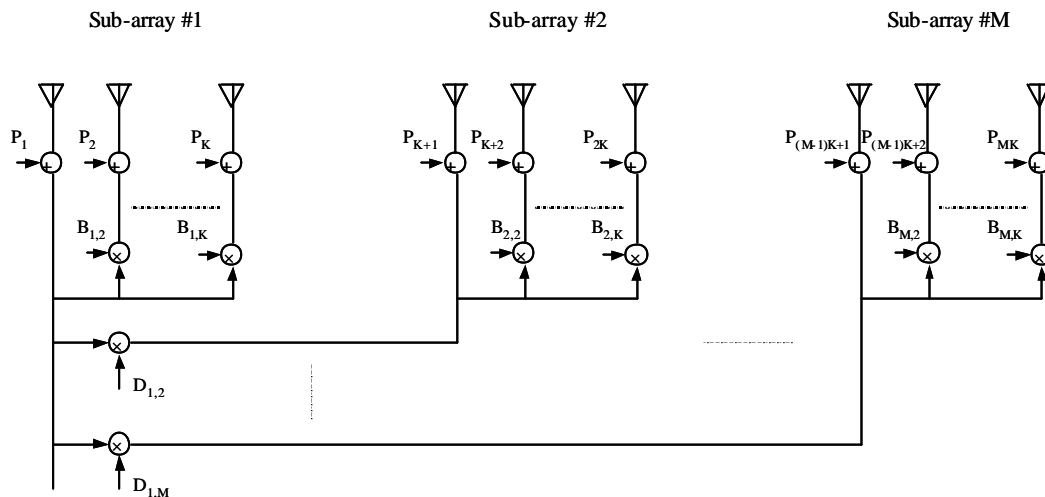

Figure 10. Hierarchical weighting for the transmit antenna diversity/beamforming

### 5.4.2. Example format of feedback information

The following frame formats for the feedback information bits are desirable. Format 1 is for Tx diversity and it allows employing the scheme without beamforming features. Format 2 is for beamforming with small inter-element spacing less than spatial correlation length. All of 15 bits/frame for beamformer weights can be used for accurate control of the beam. Format 3 is for combination of diversity and beamforming, which is suitable for the sub-array antenna configuration. Single beamformer weight is quantized by 3 bits and fed back in a frame to Node B. In case of two-sub-array system, the beamformer weight of sub-array #1 is transmitted in the first frame, then the beamformer weight of sub-array #2 is transmitted in the second frame. The number of antenna elements in each sub-array can be increased, as long as the feedback delay is permissible for updating the beamformer weights.

Table 4. Multiplexing format 1 of feedback information for Tx diversity

Slot #	1	2	3	4	5	6	7	8	9	10	11	12	13	14	15
FB bits for D	1	1	1	1	1	1	1	1	1	1	1	1	1	1	1
FB bits for B	0	0	0	0	0	0	0	0	0	0	0	0	0	0	0

Table 5. Multiplexing format 2 of feedback information for beamforming

Slot #	1	2	3	4	5	6	7	8	9	10	11	12	13	14	15
FB bits for D	0	0	0	0	0	0	0	0	0	0	0	0	0	0	0
FB bits for B	1	1	1	1	1	1	1	1	1	1	1	1	1	1	1

Table 6. Multiplexing format 3 of feedback information for combination of diversity and beamforming

Slot #	1	2	3	4	5	6	7	8	9	10	11	12	13	14	15
FB bits for D	1	1	1	1	0	1	1	1	1	0	1	1	1	1	0
FB bits for B	0	0	0	0	1	0	0	0	0	1	0	0	0	0	1

## 5.5 Closed loop transmit diversity mode 2 with reduced states for 4 elements

Similar to Rel-99 closed loop Tx diversity systems, the weights of transmit antennas are determined at a mobile station and fed back to the base station. The set of weights at the UTRAN-AP  $\underline{w} = [w_1 w_2 \dots w_i \dots w_M]^T$ , where  $w_i$  is a complex weight associated with the  $i$ th Tx antenna are chosen to maximize  $P$  below:

$$P \propto \underline{w}^H H^H H \underline{w}, \quad (5)$$

where  $H = [\underline{h}_1 \ \underline{h}_2 \ \dots \ \underline{h}_i \ \dots \ \underline{h}_M]$  and  $M$  is the number of Tx antennas. The column vector  $\underline{h}_i$  represents an estimated channel impulse response for the  $i$ th Tx antenna, and its vector length equals to the number of paths.

Recalling the description of the modified mode 2 CL transmit diversity (“Mode2\_4p0g”) in R1-00-1132, we consider 4 phase states per element which are defined in Table 1.

Table 7. FSM of modified closed loop mode 2 signalling message per element

FSM	Phase difference between antennas (degrees)
00	?
01	-?/2
11	?/2
10	0

Therefore we need 6 bits feedback per slot for the update of the antenna coefficients. If we consider **1 bit feedback per slot**, Progressive refinement (as described for Rel 99 Closed loop transmit diversity Mode 2) is used to update the antenna coefficients.

### 5.5.1 Format of Feedback Information

The uplink feedback information signalling is similar to the Rel-99 mode 2, that is using progressive refinement both at the UE and UTRAN-AP. The only change is the number of states, at the UE, to be compared for maximising  $P \propto \underline{w}^H H^H H \underline{w}$ , is increased due to 4 elements instead of 2 (Rel 99) and the FSM (Table 8) corresponding to coefficient of the antenna 2, 3 and 4 are sent successively.

---

## 6 Performance

### 6.1 Link level simulation assumptions

#### 6.1.1 Regular simulation assumptions

Table 8 lists the simulation parameters that should be used in the Tx diversity simulations.

Table 8. Recommended simulation parameters for multiantenna Tx diversity simulations.

Bit Rate	12.2 kbps
Chip Rate	3.84 Mcps
Convolutional code rate	1/3

<b>Carrier frequency</b>	2 GHz
<b>Power control rate</b>	1500 Hz
<b>PC error rate</b>	4 %
<b>PC Step Size</b>	1 dB per antenna
<b>Channel model(s) and UE velocities</b>	1-path Rayleigh: 3, 10, 40, 120 km/h Modified ITU Ped A: 3, 10, 40 km/h Modified ITU Veh. A: 10, 40, 120 km/h
<b>CL feedback bit error rate</b>	4 %
<b>CL feedback delay</b>	1 slot
<b>TTI</b>	20 ms
<b>Downlink DPCH slot format</b>	#10 or #11
<b>Min. # of RAKE fingers for modified Vehicular A channel</b>	5
<b>Target FER/BlkER</b>	1 %
<b>Geometry (G)</b>	-3, 0 and 6 dB
<b>Common Pilot</b>	-10 dB total
<b>Correlation between antennas</b>	0
<b>Performance measure</b>	$T_x E_b/I_{or}$
<b>CL feedback rate</b>	1500 Hz

The following notes should be taken:

1. Definition of Tx  $E_b/I_{or}$

$E_b$  = The average energy per information bit as measured at the base station. Defined after CRC attachment but before channel encoding.

$I_{or}$  = The total power density of the base stations in soft handoff with the mobile, measured at the base station

2. Definition of Geometry (G)

Geometry, G, is defined as:

$$G = \frac{\text{average}(R_x I_{or})}{I_{oc} + N_o} \quad (10)$$

where,

$R_x I_{or}$  = The total power density of the base stations in soft handoff with the mobile, measured at the mobile station

$I_{oc}$  = The interference power density at a mobile due to all the base stations not in soft handoff with the mobile

$N_o$  = The thermal noise power spectral density

3. Power control step size

The power control step size is 1 dB per antenna. This means that when up/down command is received the transmitter increases/decreases the Tx power per antenna by 1 dB which also results in 1 dB increase/decrease of the total Tx power.

4. Modeling of downlink channels

The only common channel modeled in downlink is the CPICH. The detailed implementation of the CPICH can vary but the total power allocated to it is 10 % of the total Tx power of the BS. This 10 % allocation needs to be valid only in the beginning of the simulation, i.e. the CPICH total power is kept fixed during the simulation. Thus, the change of the user signal power due to power control does not affect the total CPICH Tx power.

#### 5. Modified ITU channel models

As all of the path delays of the ITU channel models will not be multiples of the the length of one chip the channel models will be modified. In case a path (ray) is between two channel delay samples, the following modification will be done:

?? The ray is split into two rays, one to the sample to the left and one to the sample to the right. The power of these new rays is such that the sum is equal to the original power, and the power of each of the new rays is proportional to the (1-normalised distance to the original ray). Finally, the power of all rays on one sample are added up and normalised to yield total channel power of 1.

Consider the example shown in the Figure 11 . In this case a path of power  $P$  located between two delay samples ( $T_c =$  length of a chip in time) is split to two separate paths with power  $0.75P$  at delay sample  $k$  and power  $0.25P$  at delay sample  $k+1$ .

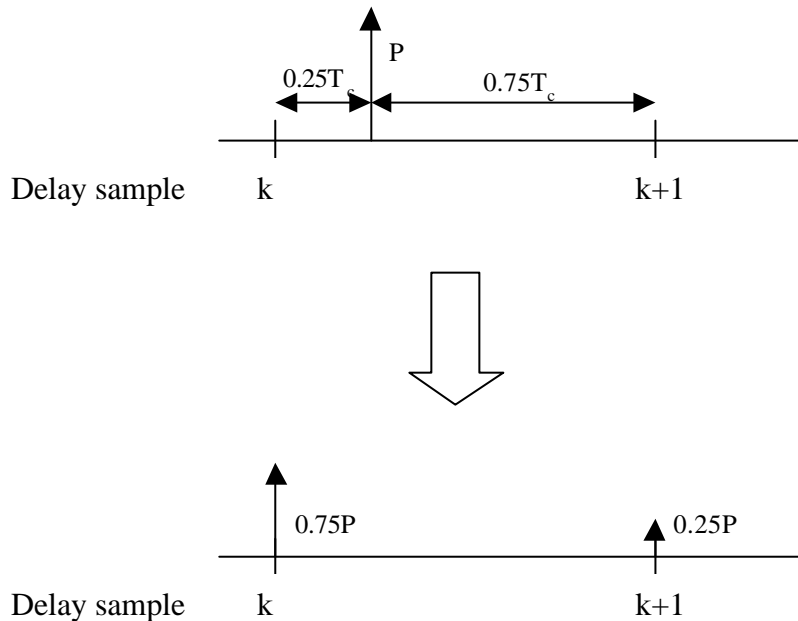

**Figure 11. Example of a modification of one path.**

#### 6. Number of RAKE fingers

As the ray splitting technique leads to a high number of channel taps in case of Vehicular A channel the minimum number of RAKE fingers that should be used in simulations has been set to 5.

### 6.1.2 Additional simulation assumptions for the eigenbeamformer

?? The feedback error rate for short term bits for switching the eigenbeams was 4%. The long term feedback to transmit the eigenvectors was assumed to be error free [simulations with 4% error rate on long term feedback will be provided in future].

?? The eigenvectors were quantized with 5 bits for phase and 3 bits for amplitude of each vector element.

?? Ideal antenna verification was assumed at the UE.

?? Correlation between antennas was assumed as described in the following section.



### 6.1.2.1 Channel model for correlated antennas

The channel model described in [5] is extended by incorporating spatial correlation between the signals from antennas  $m$  and  $n$  of the base station, denoted by  $\rho_{m,n}$ , which are general complex numbers. The corresponding matrix capturing all correlation coefficients is denoted by  $\mathbf{R} = [\rho_{m,n}]$  of size  $M \times M$  when  $M$  antennas are used. Assuming Rayleigh fading for each antenna, the receive vector  $\mathbf{x}(t)$  at the UE can be expressed by an overlay of  $M$  independent and normalized complex Gaussian fading processes  $\mathbf{g}(t) = [g_1(t) \ g_2(t) \ \dots \ g_M(t)]^T$ , with Jakes power density spectrum, i.e.,

$$\mathbf{x}(t) = \sqrt{P} \mathbf{h}(t) u(t) \tag{11}$$

where

$$\mathbf{h}(t) = \mathbf{R}^{1/2} \mathbf{g}(t) \tag{12}$$

is the  $M$ -dimensional channel vector. Here,  $u(t)$  and  $P$  denote the transmitted signal and the transmit power per antenna, respectively. Figure 12 shows the applied model.

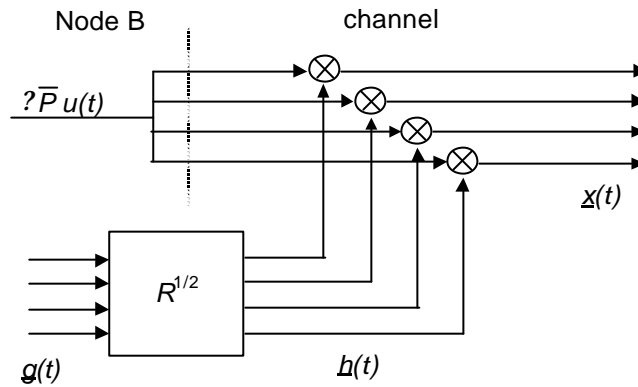

**Figure 12. Correlated channel model. Here, the Node B is shown without channel weights applied to the antennas.**

By taking the expected value of the receive vector, it can be verified:  $E\{\mathbf{x}\mathbf{x}^H\} / P = \mathbf{R}$  (Note:  $\mathbf{R}^{1/2} \mathbf{R}^{1/2H} = \mathbf{R}$ ).

### 6.1.2.2 Parameters for micro and macro cell scenarios

Based on a comparison with mathematical descriptions of propagation models [7] two parameters sets for the correlation coefficients have been defined. These correspond to a micro cell scenario and a macro cell scenario.

?? Micro cell

$$\mathbf{R} = \begin{bmatrix} 1 & a & b & c \\ a^* & 1 & a & b \\ b^* & a^* & 1 & a \\ c^* & b^* & a^* & 1 \end{bmatrix} \quad \text{where } a = 0.7 e^{j2.2}, b = 0.1 e^{j1.2}, c = 0.2 e^{j3.0}$$

The correlation coefficients of this matrix correspond to planar waves which power is uniformly distributed in an angular spread of  $45^\circ$ .

?? Macro cell

$$R = \begin{bmatrix} 1 & a & b & c \\ a^* & 1 & a & b \\ b^* & a^* & 1 & a \\ c^* & b^* & a^* & 1 \end{bmatrix} \quad \text{where } a = 0.97 e^{j0.8}, b = 0.94 e^{j1.6}, c = 0.88 e^{j2.4}$$

The correlation coefficients of this matrix correspond to planar waves which power is uniformly distributed in an angular spread of  $10^\circ$ .

Details on the derivation of these parameters can be found in [7, 8].

### 6.1.3 Basis selection for > 2 Tx antennas

Basic link level simulation assumptions described in [5] and additional assumptions described Table 9. were used.

**Table 9. Additional simulation parameters.**

Comparing output	<i>Ec/Ior</i>
Modulation	<i>QPSK</i>
Physical channel rate	<i>30ksps</i>
Number of antennas	<i>Release 99: 2, Release 2000: 4 (New)</i>
Total FSM bits	<i>Release 99 Mode2: 4bits Release 2000 Case I (4C2): 5bits Case II (4C3): 6bits</i>
Slot format	<i>#10 (6,2,0,24,8)</i>
Channel estimation	<i>WMSA – 4slots (1,4,4,1)</i>
MPI modeling	<i>All noncoherent except self (Fig1 and 2) Coherent and noncoherent (Fig 3 and 4)</i>

### 6.1.4. Additional simulation parameters for the Tx diversity scheme with beamforming feature

Table 10 lists the additional simulation parameters that should be used for the Tx diversity scheme with beamforming feature. The frame format for the feedback information bits shown in Table 6 are used for the simulation.

**Table 10. Additional simulation parameters**

Channel estimation	from CPICH with ideal weight verification
Correlation between antennas	0: between diversity branches 1: among each sub-array
UE location	preserving $0^\circ$ direction from Node B
Multipath angular spread	$0^\circ$
BF weight step size	$45^\circ$
BF element space	$\lambda/2$

## 6.2 Link level simulation results

### 6.2.1 Link level simulation results of the eigenbeamformer

#### 6.2.1.1 Uncorrelated case

In Figure 13 the performance of the eigenbeamformer with switching between  $N_{\text{beam}} = 4$  eigenvectors compared to the Release-99 mode 1 with two antennas is shown. The eigenbeamformer performs about 2.2 dB better than Release-99 mode 1 for the UE velocity of 3 km/h and 10 km/h. Using four eigenbeams in an uncorrelated scenario has the result that each antenna element is addressed by one eigenbeam and effectively switching between antenna elements is done.

For higher velocities the Release-99 mode 1 with only two antennas will have the same or better performance. This can be explained with the increased number of feedback bits for 4 antenna elements which cannot be transmitted fast enough.

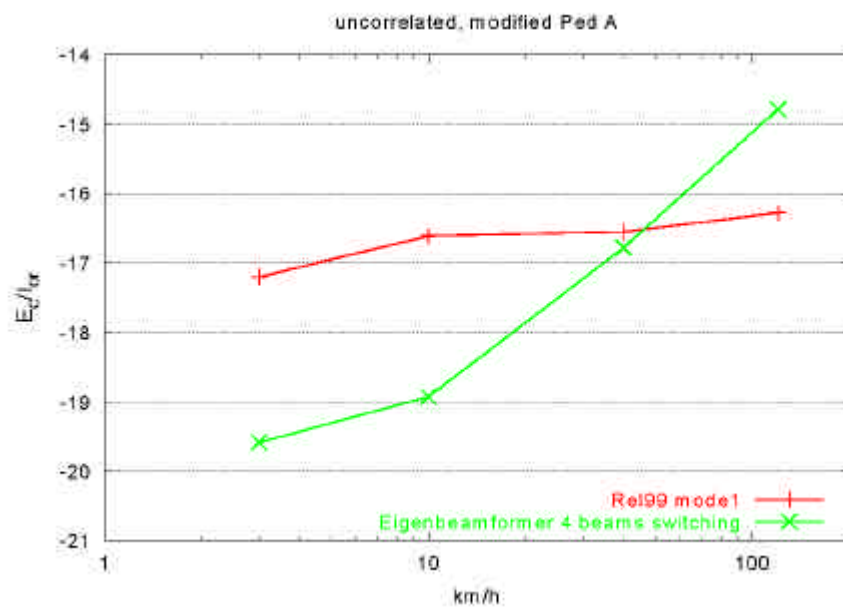
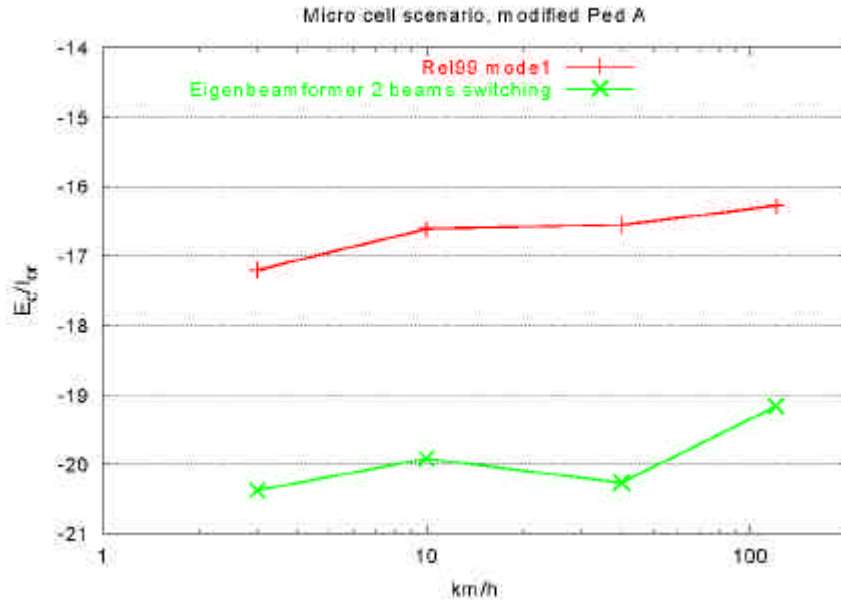

**Figure 13. Simulation results for 0 dB geometry and uncorrelated antenna paths**

Note that the velocity of 120 km/h is shown here for explanation of the behaviour and is quite unrealistic for the assumed Pedestrian A channel model.

#### 6.2.1.2 Micro cell scenario

For the micro cell scenario switching between  $N_{\text{beam}} = 2$  eigenbeams was done. For all simulated velocities the eigenbeamformer performs with an advantage of about 3 dB compared to Release-99 mode 1.

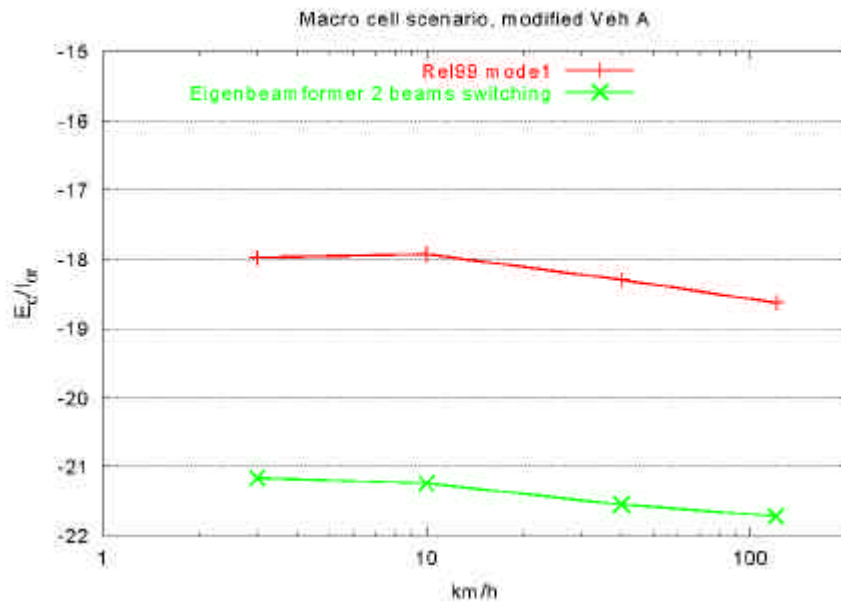

**Figure 14. Simulation results for 0 dB geometry and micro cell scenario**

Note that the velocity of 120 km/h is shown here for explanation of the behaviour and is quite unrealistic for the assumed Pedestrian A channel model.

### 6.2.1.3 Macro cell scenario

For the macro cell scenario also switching between  $N_{beam} = 2$  eigenbeams was done. For all simulated velocities the eigenbeamformer performs with an advantage of about 3 dB compared to Release-99 mode 1.



**Figure 15. Simulation results for 0 dB geometry and macro cell scenario**

### 6.2.2 Basis selection for > 2 Tx antennas

Release 99 scheme and two other schemes are simulated as in Table 11.

**Table 11. Scheme description**

Scheme	Description
2-mode-2	<ul style="list-style-type: none"> <li>/// Closed loop mode 2 according to Rel.99</li> <li>/// Number of Tx antennas = 2</li> <li>/// Feedback bit rate = 1500 bps</li> <li>/// Total bits of FSM = 4bits: 1bit for gain, 3bits for phase</li> </ul>
4C2	<ul style="list-style-type: none"> <li>/// Number of Tx antennas = 4</li> <li>/// Feedback bit rate = 1500 bps</li> <li>/// 2 best antenna selection among 4 transmit antenna</li> <li>/// Total bits of FSM = 5bits: 3bits for selection, 2bits for phase</li> </ul>
4C3	<ul style="list-style-type: none"> <li>/// Number of Tx antennas = 4</li> <li>/// Feedback bit rate = 1500 bps</li> <li>/// 3 best antenna selection among 4 transmit antenna</li> <li>/// Total bits of FSM = 6bits: 2bits for selection, 4bits for phase</li> </ul>

#### Single path, 0dB Geom.

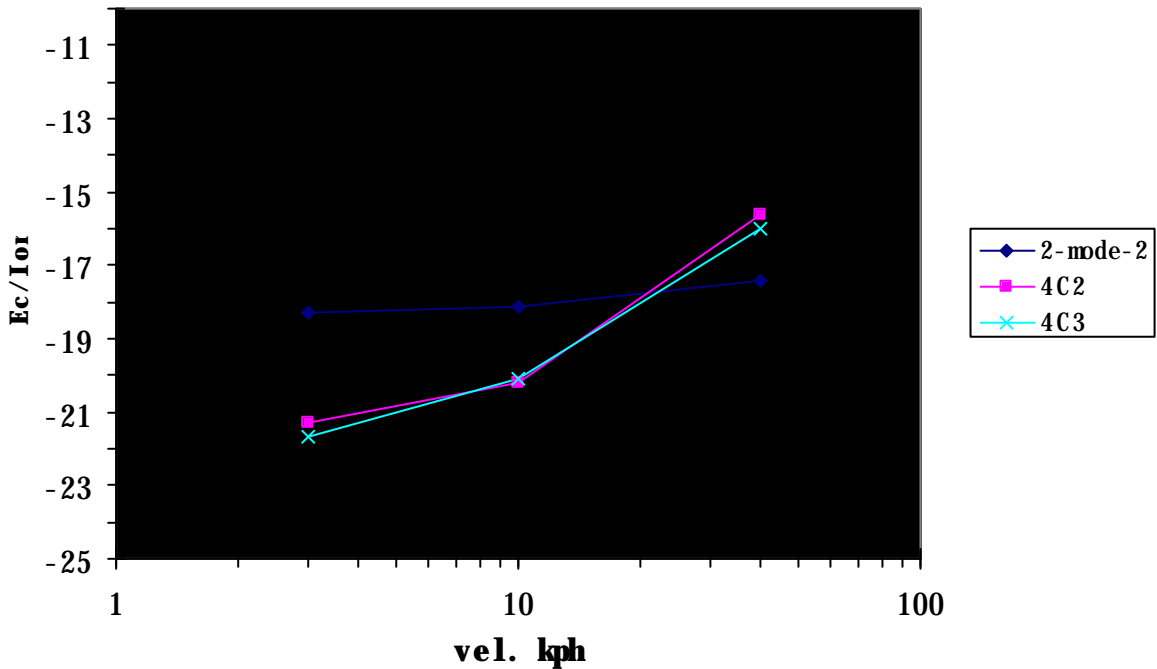

Figure 15. Single path simulation results for 0 dB geometry and 1 % FER.

**Ped A Channel, 0dB Geom.**

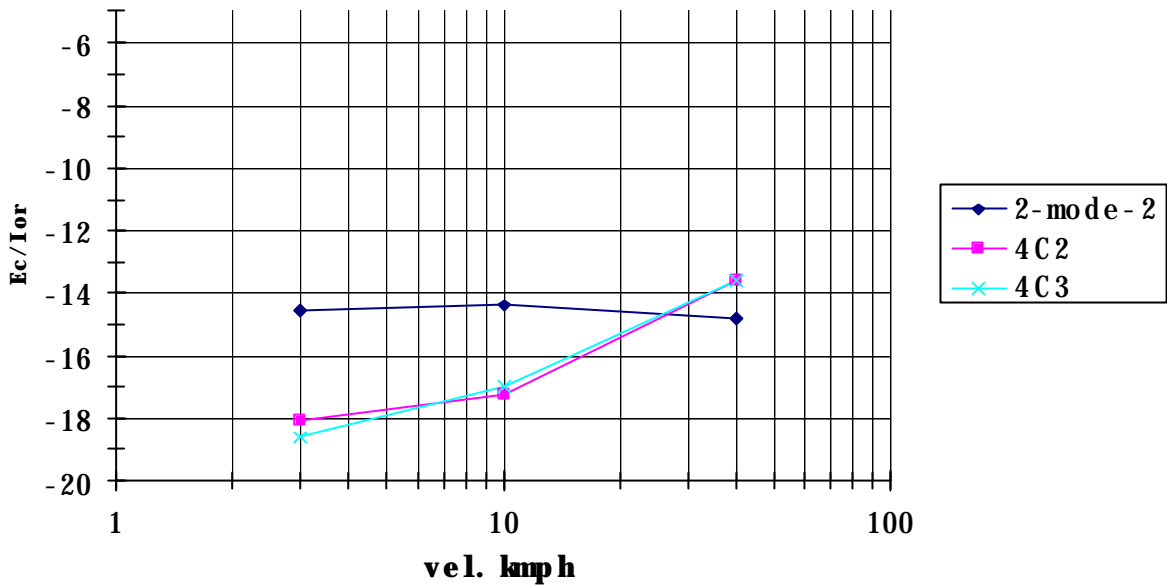

Figure 16. Simulation results for modified ITU Ped. A channel at 0 dB geometry.

**Veh A Channel, 0dB Geom.**

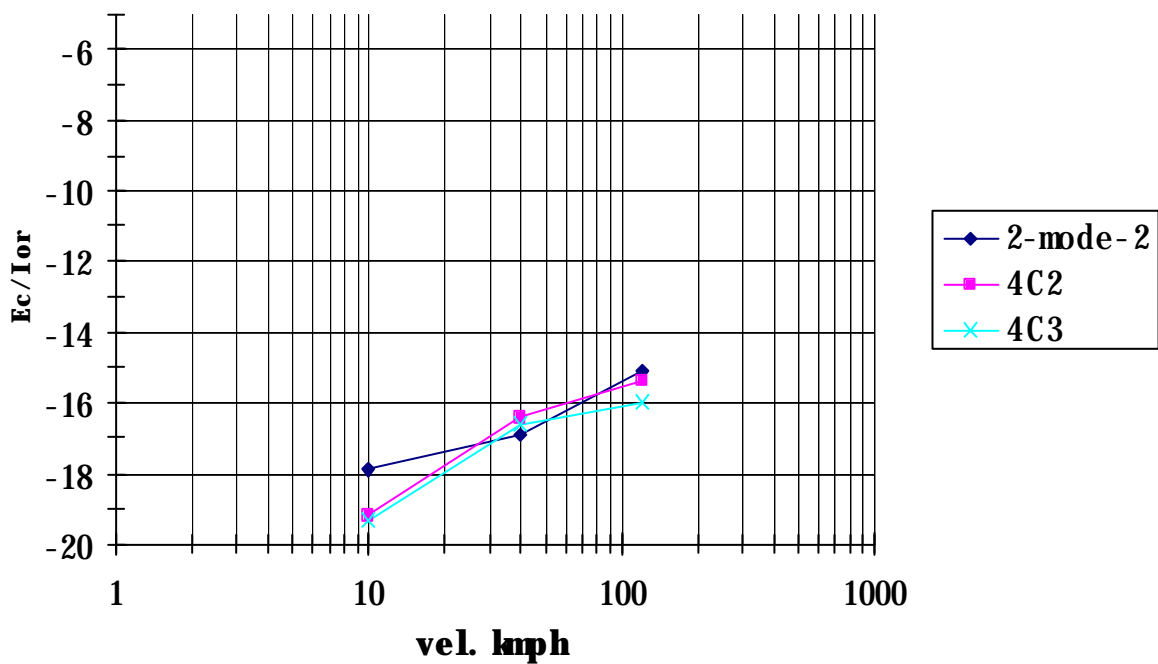

Figure 17. Simulation results for modified ITU Veh. A channel at 0 dB geometry.

In these simulation results, “2-mode-2” scheme, “4C2” scheme, and “4C3” scheme is compared. The “2-mode-2” scheme is closed loop Tx diversity mode 2 of two antennas in Rel 99. In addition, the “4C2” and “4C3” schemes are the

basis selection methods of closed loop Tx diversity for more than two antennas. In the “4C2” scheme, the UE selects two antennas among four antennas. Consequently, the UE selects three antennas in “4C3” scheme.

The results of Fig.6.3.1.1., single path case, show that the new scheme has 2.7dB@ FER=1% gain for 4C2 and 3.0dB@ FER=1% for 4C3 over the Release 99 Tx diversity Mode 2 when the UE speed is 3km/h.

As shown in Fig.6.3.1.2, the “modified ITU pedestrian A” channel model is used. The multipath model is “noncoherent”. When compared to “2-mode-2” scheme, performance gains of “4C2” scheme and “4C3” scheme are 3.5dB and 4dB, respectively. The crossover point between “2-mode-2” scheme and other schemes is about 25km/h.

In Fig.6.3.1.3, these schemes are compared in the “modified ITU vehicular A channel”. As the same as in Fig.6.3.1.2, the “noncoherent” multipath model is used. The suggested “4C2” and “4C3” scheme have better performance (approximately 1.3dB) in low speed than that of the “2-mode-2” scheme. If, however, the velocity is higher than 30km/h, performance is similar for three schemes.

## 6.2.3. Link level simulation results of the Tx diversity scheme with beamforming feature

### 6.2.3.1. Comparison with other schemes

Five different antenna schemes were simulated and compared as follows.

#### ?? 1 Ant.

?? Number of Tx antennas = 1

?? Without closed loop Tx diversity

#### ?? 2 Ant. Mode 1

?? Number of Tx antennas = 2

?? Closed loop Tx diversity Mode 1 (Release'99)

#### ?? 4 Ant. Mode 1

?? Number of Tx antennas = 4

?? Extension of closed loop Tx diversity Mode 1

#### ?? 2x2 Ant. Mode 1

?? Number of Tx antennas = 4 ( two-sub-array configuration )

?? Extension of closed loop Tx diversity Mode 1

#### ?? 2x2 Ant. BF

?? Number of Tx antennas = 4 ( two-sub-array configuration )

?? Proposed weight adaptation, see Table 6

Figure 16–Figure 18 show the simulation results for three different channel models with 0dB geometry.

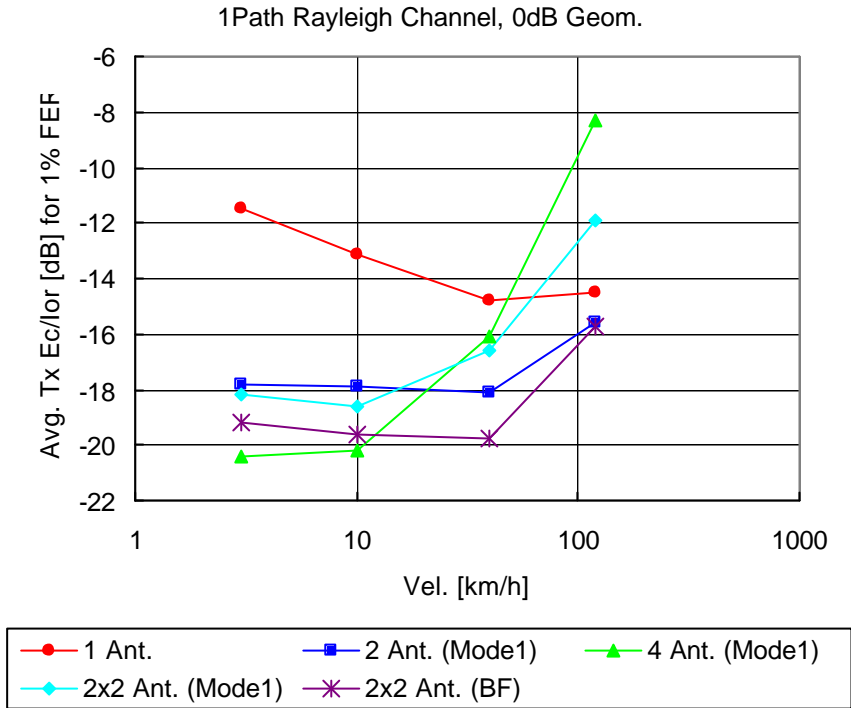

Figure 16. 1 path Rayleigh channel, 0 dB geometry

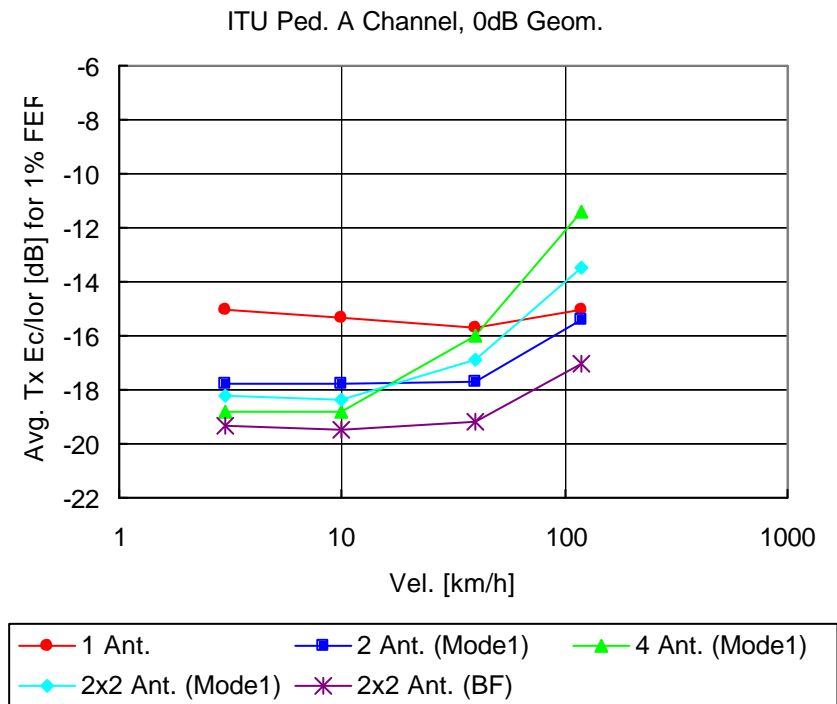

Figure 17. ITU Pedestrian A channel, 0 dB geometry



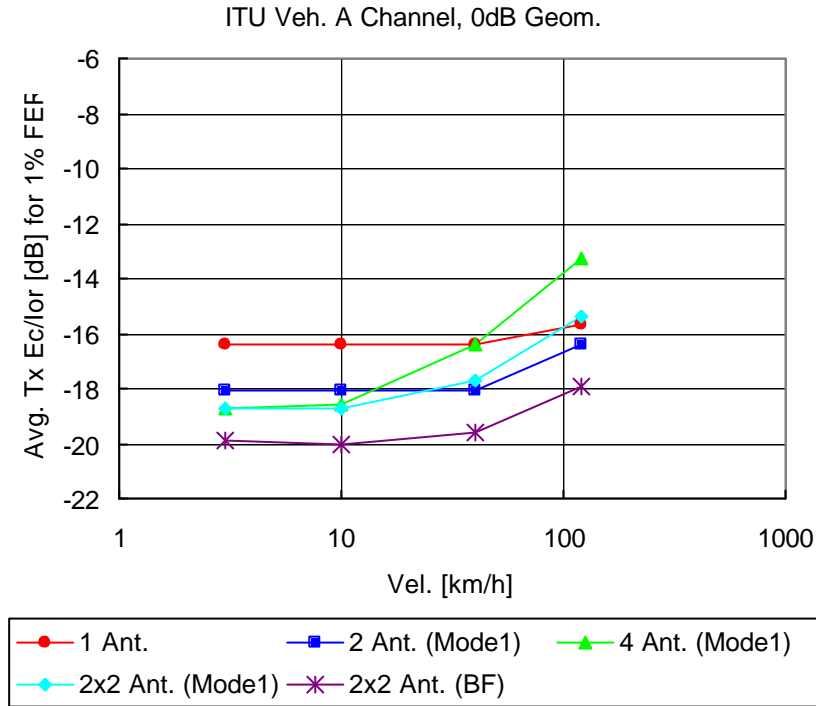

Figure 18. ITU Vehicular A channel, 0 dB geometry

### 6.2.4 Closed loop transmit diversity mode 2 with reduced states for 4 elements

<t.b.d.>

## 6.3 System level evaluation

System level evaluations are necessary to get the full understanding of e.g. impacts of different Tx diversity schemes on the cellular capacity. Generally speaking, however, decreased Tx  $E_c/I_{or}$  results in improved cellular performance. For example, when considering the cellular capacity, halving the Tx power roughly speaking doubles the capacity.

One issue to consider is the power allocated to CPICH and co-existence of terminals based on different specification releases. As such, the Tx power of the CPICH is not standardized, and it is up to the operator to define how much of the total BS power will be allocated to CPICH. As Rel.-99 terminals can utilize CPICH transmitted from 2 antennas some care must be taken when doing the network planning in case there are more than 2 Tx antennas. In Tx diversity simulations it has been assumed that the total CPICH power is 10 % of the BS power. That assumption may be too optimistic in a real deployment scenario due to existing Rel.-99 terminals. As a kind of worst case analysis you could define that when going from 2 to 4 Tx antennas the total Tx power of the CPICH will also be doubled. That would correspond to about 0.5 dB loss in Tx  $E_c/I_{or}$  performance when compared to the assumed 10 % CPICH power allocation. The worst case analysis does not account for the fact that increased CPICH power could improve channel estimation, weight calculation and weight verification performance.

## 7 Impacts to UE and UTRAN implementation

### 7.1 Impacts to UE implementation

#### 7.1.1 General impacts to UE implementation

Main complexity increase comes from RAKE implementation as number of channel estimation units increases as a function of the number of Tx antennas. Yet, even in the case of 4 Tx antennas the complexity increase due to 4 channel estimators per finger is considered to be small when compared to the case of 2 Tx antennas with 2 estimators per finger.

When CPICH based channel estimation is used some kind of weight verification algorithm seems to be necessary. That holds also for Rel.-99 mode 1. Thus, additional complexity increase comes from the need to perform the verification for e.g. 4 antennas instead of 2. The complexity increase is considered to be small although more detailed analysis is needed for the more advanced verification algorithms.

Note that if the feedback rate is kept the same as in Rel.-99, short term calculation of the feedback commands requires about the same effort as in Rel.-99 based terminals. For concepts that exploit correlation between antenna elements additional complexity is needed for the long term analysis. This is regarded as small compared to the complexity needed for calculating the short term feedback commands.

#### 7.1.2 Complexity evaluation of the eigenbeamformer concept

This evaluation is done by estimating the necessary complex multiplications. The numbers given can be regarded as the upper limit of complexity, since the actual implementation can still reduce the computational effort.

##### ?? Channel estimation

For all the proposed concepts on closed loop Tx diversity with  $M = 4$  antenna elements, the UE has to perform a short term channel estimate over the antenna elements at  $N$  dominant temporal taps. To calculate for example  $N = 4$  spatial channel estimation vectors  $\mathbf{h}_n$  of length  $M$  from the global pilots,  $N \cdot M = 16$  complex multiplications per slot are necessary regardless of the diversity concept used.

##### ?? Calculation of matrix update

It is assumed that the update in equation (2) is calculated every 5th frame to be used for the long term averaging. The covariance matrix  $\mathbf{R}_{ST}$  is symmetric, so for each tap  $(M+1) \cdot M/2$  complex multiplications (and additions) are needed. Over all taps

$\frac{M \cdot (M+1) \cdot N}{2}$  complex multiplications (and additions) per slot are needed. Assuming  $N = 4$  taps this results in 0.53 complex multiplications per slot.

##### ?? Calculation of eigenbeams (long term processing)

The power method can be used for the calculation of the eigenbeams. It is assumed that 4 iterations are sufficient to yield one dominant eigenbeam. Thus, the complexity approximately equals  $4 \cdot M \cdot M$  multiplications for each eigenbeam.

Further, it is assumed that for each eigenbeam this calculation is done every 300 ms which equals to 30 frames (each frame consists of 15 slots). So this concludes to

$4 \cdot M \cdot M / 15 \cdot 30 (= 0.14)$  complex multiplications per slot in average.

Advanced methods could be used based on subsequent updating of the eigenbeams which significantly reduce the computational effort.

##### ?? Eigenbeam selection (short term processing)

For each eigenbeam the UE receive power has to be calculated, e.g. using equation (4). This implies about  $2 \cdot M \cdot N (= 32)$  complex multiplications per slot. The eigenbeam which yields the highest power is selected. Since for the other

proposals a similar processing as the short term selection has to be performed, about 32 complex multiplications would be also necessary. If progressive refinement is used, the complexity would be higher for these proposals.

Thus, the eigenbeamformer comes at the cost of  $0.53 + 0.14 = 0.67$  complex multiplications per slot (matrix update and calculation of eigenbeams) which is relatively low with respect to  $16 + 32 = 48$  complex multiplications that are necessary in any case for an extension of the closed loop Tx diversity concept.

### 7.1.3 Basis selection scheme for > 2 Tx antennas

In order to obtain feedback weight in UE, it is necessary to perform the matrix operation in Eq. (5). In general, it is known that the searching is one of the efficient methods to calculate the weight for antennas. If the number of antenna is limited by selection, then the complexity of calculation could be reduced.

In detail, the number of multiplication of Eq. (5) is proportional to  $M^2+M$  if the weight for each antenna is transmitted, where  $M$  denotes the number of antenna. It is worth noting that the  $(M^2+M)$  is for only one weight vector. Thus the resultant number of multiplication is proportional to (size of weight vector set) \*  $(M^2+M)$ . Note that the size of weight vector set is  $L^M$ , where  $L=2^{N_c}$  is the possible number of weight vector per antenna.

If the weight for the reference antenna is set to one, then the number of multiplication is proportional to (size of weight vector set) \*  $(M(M-1)+M-1)$ , where the size of weight vector is  $L^{M-1}$ .

If the number of transmit antenna is reduced to  $S$ , then the number of multiplication reduces to (size of weight vector set) \*  $(S(S-1)+S-1)$ . In this case, the size of weight vector set reduces to  $M C_S * L^{S-1}$  due to the reduced number of antenna.

For example, in case of  $M=4$ ,  $S=2$ ,  $N_c=2$ , the number of multiplication of the proposed scheme is proportional to  $6*4*3=72$  while that of the full representation with reference antenna is  $4^4*3*(12+3)=64*15=960$ . Note that in case of  $M=2$ ,  $N_c=4$  (3GPP Mode 2), the number of multiplication is  $16*3=48$ .

### 7.1.4 Complexity evaluation of the Tx diversity scheme with beamforming feature

#### ?Estimation of spatial channel vectors

For all of the closed loop Tx diversity proposals, the UE should perform channel estimation over  $N$  antenna elements at  $L$  dominant temporal taps. This yields  $N$  channel estimation vectors of length  $L$ . Both the channel estimation using CPICH for Tx diversity/beamforming control and the channel estimation using DPCCH for antenna verification or RAKE combining will be necessary.  $(N*L*10)+(N*L*N_{dp})$  complex additions are required for channel estimation (CPICH+DPCCH), where  $N_{dp}$  is the number of pilot symbols in DPCCH.  $(M-1)*L$  complex multiplications is required for the antenna verification. In case of  $N=4$  and  $M=2$ , the number of complex multiplications of  $L$  is identical to that of the conventional 2-branch diversity scheme.

#### ?Calculation of diversity weights

The weights are calculated by using  $M$  channel response vectors of length  $L$  in which one vector from each sub-array, where  $M$  is the number of sub-arrays. The calculation method described in Section 3.1 is same as that specified in the current closed-loop Tx diversity modes. In case of  $M=2$ , the complexity is same as that of the conventional 2-branch diversity scheme.

#### ?Calculation of beamforming weights

The weights are calculated by using  $K=N/M$  channel response vectors of length  $L$  for each sub-array. In case of  $M=2$  and  $N=2$ ,  $M*L*(K-1)=8$  complex multiplications are required.

The complexity of the case  $N=4$ ,  $M=2$  and the conventional 2-branch diversity are shown in Table 12, where  $L=4$ ,  $N_{dp}=4$ . Most of the additional complexity comes from the channel estimation and the algorithm complexity is relatively small.

**Table 12. Complexity of UE**

	2-branch	4-branch (M=2)
Complex additions	116	232
Complex multiplications	$4+4+0=8$	$4+8+8=20$

## 7.2 Impacts to UTRAN implementation

### 7.2.1 General impacts to UTRAN implementation

If the number of Tx antennas is increased, the number of power amplifiers is increased accordingly. However, Tx power per amplifier can be lower as the total power is split between several amplifiers by which the PA requirements can be alleviated.

### 7.2.2 Eigenbeamformer concept

A small memory for storing the current eigenvector set at the UTRAN would be needed.

### 7.2.3. Tx diversity scheme with beamforming feature

The higher layer signaling information about Tx antenna configurations of Node B to UE is necessary to achieve efficient multiple antennas diversity/beamforming gain. An appropriate feedback frame format information should also be transmitted through higher layer signaling.

The procedure in soft handover is one of the most important issues for the feasibility study. Two handover methods were proposed for the Tx diversity scheme with beamforming feature.

?? The common feedback weight is used to control the beamformer weights of active set of Node B.

?? The individual beamformer weight is calculated and fed back in sequence among active set of Node B.

The former is the same method as described in Release'99 specification. In the latter method, the feedback delay occurs in proportion to the number of Node Bs. Since the UE in handover mode generally locates at cell edge, it is expected that the permissible feedback delay becomes much longer. However, this method needs higher layer signaling to assign the order of Node B, whose beamformer weights are transmitted in sequence from UE. On the other hand, the Tx diversity weight, that is vulnerable to feedback delay, is calculated and fed back to Node B in the same manner as described in Release'99 specification.

---

## 8 Impacts to physical layer operation

### 8.1 Definition of additional orthogonal pilot sequences

Additional orthogonal dedicated pilot sequences should be defined as many verification methods require the use of them. For dedicated pilot of length  $> 2$  bits it is easy to do but the special case of length 2 bit pilot is more problematic. Some further studies on verification algorithms are needed.

CPICH used for weight calculation at UE should be transmitted from all of the Tx antennas. Furthermore, the CPICH from the different antennas should be orthogonal. Thus, additional orthogonal symbol sequences for Primary-CPICH should be defined or, alternatively, Secondary-CPICHs could be used.

### 8.2 Eigenbeamformer concept

The procedures for initialization and compressed mode singularities will be defined for the eigenbeamformer concept in a straightforward way.

---

## 9 Backwards compatibility to Release-99

### 9.1 Eigenbeamformer concept

With the eigenbeamformer no backward compatibility problem is identified for Release-99.

### 9.2 Basis selection scheme for $> 2$ Tx antennas

### 9.3 New CPICH Transmission scheme for $> 2$ Tx antennas

This proposed scheme satisfies the backward compatibility with Release 99 2-ant diversity UE. The proper common/dedicated physical channel transmission scheme is also considered to be used with the proposed CPICH transmission scheme. With only one additional channelisation code, the proposed CPICH transmission scheme can be used as diversity pilot for 4 transmit antenna.

---

## 10 Conclusions

### History

Document history		
Date	Version	Comment
	0.1.0	First draft
Editor for 3G TR 25.869 is: Sung Jin Kim		

<b>Document history</b>		
<b>Date</b>	<b>Version</b>	<b>Comment</b>
Tel. : +82-31-280-8175 Fax : +82-31-280-9207 Email : desjkim@sait.samsung.co.kr		
This document is written in Microsoft Word version.		