

**TSG-RAN Meeting #7**  
**Madrid, Spain, 13 - 15 March 2000**

**TSGRP#7(00)0098**

**Title:** Agreed CRs to TS 25.422

**Source:** TSG-RAN WG3

**Agenda item:** 6.4.3

Tdoc_Num	Specification	CR_Num	Revision_Num	CR_Subject	CR_Category	WG_Status	Cur_Ver_Num	New_Ver_Num
R3-000418	25.422	001		Removal of ATM Protection Switching	C	agreed	3.2.0	3.3.0
R3-000820	25.422	003	1	Update to R3-000676	F	agreed	3.2.0	3.3.0



## CHANGE REQUEST

**25.422 CR 001**

Current Version: **3.2.0**

↑ CR number as allocated by MCC support team

For submission to: **RAN#7**  
list expected approval meeting # here ↑

for approval   
for information

strategic   
non-strategic  (for SMG use only)

Form: CR cover sheet, version 2 for 3GPP and SMG The latest version of this form is available from: <ftp://ftp.3gpp.org/Information/CR-Form-v2.doc>

**Proposed change affects:**  
(at least one should be marked with an X)

(U)SIM

ME

UTRAN / Radio

Core Network

**Source:** RAN-WG3

**Date:** 22<sup>nd</sup> Feb. 2000

**Subject:** Removal of ATM Protection Switching

**Work item:**

**Category:**

(only one category shall be marked with an X)

F Correction   
A Corresponds to a correction in an earlier release   
B Addition of feature   
C Functional modification of feature   
D Editorial modification

**Release:**

Phase 2   
Release 96   
Release 97   
Release 98   
Release 99   
Release 00

**Reason for change:**

As agreed at RAN WG3#10 the ATM Protection Switching is removed from Iu and Iur interface specifications. This CR is one of the two missing CRs from the last meeting.

**Clauses affected:** Chapter 2 and 4.2

**Other specs affected:**

Other 3G core specifications  → List of CRs:  
Other GSM core specifications  → List of CRs:  
MS test specifications  → List of CRs:  
BSS test specifications  → List of CRs:  
O&M specifications  → List of CRs:

**Other comments:**

---

## 2 References

The following documents contain provisions, which, through reference in this text, constitute provisions of the present document.

- References are either specific (identified by date of publication, edition number, version number, etc.) or non-specific.
- For a specific reference, subsequent revisions do not apply.
- For a non-specific reference, the latest version applies.
- A non-specific reference to an ETS shall also be taken to refer to later versions published as an EN with the same number.

- [1] Q.2100 (7/94) B-ISDN Signalling ATM Adaptation Layer (SAAL) - overview description.
- [2] Q.2110 (7/94) B-ISDN ATM adaptation layer - Service Specific Connection Oriented Protocol (SSCOP).
- [3] Q.2140 (2/95) B-ISDN ATM adaptation layer - Service Specific Co-ordination Function for signalling at the Network Node Interface (SSCF AT NNI).
- [4] Q.2210 (7/96) Message transfer part level 3 functions and messages using the services of ITU-T Recommendation Q.2140.
- [5] I.361 (11/95) B-ISDN ATM layer specification.
- [6] I.363.5 (8/96) B-ISDN ATM Adaptation Layer Type 5.
- [7] Q.711 (7/96) Functional description of the signalling connection control part.
- [8] Q.712 (7/96) Definition and function of Signalling connection control part messages.
- [9] Q.713 (7/96) Signalling connection control part formats and codes.
- [10] Q.714 (7/96) Signalling connection control part procedures.
- [11] Q.715 (7/96) Signalling connection control part user guide.
- [12] Q.716 (3/93) Signalling Connection Control Part (SCCP) performance.
- [13] IETF RFC 791 (9/1981): Internet Protocol.
- [14] IETF RFC 1483 (7/1993): "Multi protocol Encapsulation over ATM Adaptation Layer 5".
- [15] IETF RFC 2225 (4/1998): "Classical IP and ARP over ATM".
- [16] IETF RFC 768 (8/1980): "User Datagram Protocol".
- [17] R. Stewart et al, "Simple Control Transmission Protocol", draft-ietf-sigtran-sctp-v0.txt (Work In Progress), IETF, September 1999.
- [18] G. Sidebottom et al, "SS7 ISUP Tunnelling", draft-ietf-sigtran-itun-00.txt (Work In Progress), IETF, June 1999.
- [19] ~~ITU T Rec. I.630 (2/99) ATM Protection Switching.~~

---

## 4 ATM Layer

### 4.1 General

ATM shall be used in the radio network control plane according to I.361 [5].

### ~~4.2 Protection Switching at ATM Layer~~

~~If redundancy of pathways at ATM layer between RNCs is supported, it shall be implemented using ATM Protection Switching according to I.630 [19].~~

<h2 style="margin: 0;">CHANGE REQUEST</h2>		<small>Please see embedded help file at the bottom of this page for instructions on how to fill in this form correctly.</small>
<b>25.422</b>	<b>CR</b>	<b>003r1</b>
<small>GSM (AA.BB) or 3G (AA.BBB) specification number ↑</small>		<small>Current Version: 3.2.0</small>
<small>↑ CR number as allocated by MCC support team</small>		
For submission to: <b>TSG-RAN#7</b>	for approval <input checked="" type="checkbox"/>	strategic <input type="checkbox"/>
<small>list expected approval meeting # here ↑</small>	for information <input type="checkbox"/>	non-strategic <input type="checkbox"/> <small>(for SMG use only)</small>

Form: CR cover sheet, version 2 for 3GPP and SMG The latest version of this form is available from: ftp://ftp.3gpp.org/Information/CR-Form-v2.doc

**Proposed change affects:** (U)SIM  ME  UTRAN / Radio  Core Network   
(at least one should be marked with an X)

**Source:** RAN-WG3 **Date:** 28 Feb 2000

**Subject:** Protocol stack updates – lur control plane

**Work item:**

<b>Category:</b>	F Correction <input checked="" type="checkbox"/>	<b>Release:</b>	Phase 2 <input type="checkbox"/>
<small>(only one category shall be marked with an X)</small>	A Corresponds to a correction in an earlier release <input type="checkbox"/>		Release 96 <input type="checkbox"/>
	B Addition of feature <input type="checkbox"/>		Release 97 <input type="checkbox"/>
	C Functional modification of feature <input type="checkbox"/>		Release 98 <input type="checkbox"/>
	D Editorial modification <input type="checkbox"/>		Release 99 <input checked="" type="checkbox"/>
			Release 00 <input type="checkbox"/>

**Reason for change:** RNSAP protocol stack for IP domain updated to use M3UA instead of ITUN. SCTP runs over IP – UDP removed.

**Clauses affected:** 2 References  
5.2 Signalling Bearer

<b>Other specs affected:</b>	Other 3G core specifications <input type="checkbox"/>	→ List of CRs:	
	Other GSM core specifications <input type="checkbox"/>	→ List of CRs:	
	MS test specifications <input type="checkbox"/>	→ List of CRs:	
	BSS test specifications <input type="checkbox"/>	→ List of CRs:	
	O&M specifications <input type="checkbox"/>	→ List of CRs:	

**Other comments:**



help.doc

<----- double-click here for help and instructions on how to create a CR.

## 2 References

The following documents contain provisions, which, through reference in this text, constitute provisions of the present document.

- References are either specific (identified by date of publication, edition number, version number, etc.) or non-specific.
- For a specific reference, subsequent revisions do not apply.
- For a non-specific reference, the latest version applies.
- A non-specific reference to an ETS shall also be taken to refer to later versions published as an EN with the same number.

- [1] Q.2100 (7/94) B-ISDN Signalling ATM Adaptation Layer (SAAL) - overview description.
- [2] Q.2110 (7/94) B-ISDN ATM adaptation layer - Service Specific Connection Oriented Protocol (SSCOP).
- [3] Q.2140 (2/95) B-ISDN ATM adaptation layer - Service Specific Co-ordination Function for signalling at the Network Node Interface (SSCF AT NNI).
- [4] Q.2210 (7/96) Message transfer part level 3 functions and messages using the services of ITU-T Recommendation Q.2140.
- [5] I.361 (11/95) B-ISDN ATM layer specification.
- [6] I.363.5 (8/96) B-ISDN ATM Adaptation Layer Type 5.
- [7] Q.711 (7/96) Functional description of the signalling connection control part.
- [8] Q.712 (7/96) Definition and function of Signalling connection control part messages.
- [9] Q.713 (7/96) Signalling connection control part formats and codes.
- [10] Q.714 (7/96) Signalling connection control part procedures.
- [11] Q.715 (7/96) Signalling connection control part user guide.
- [12] Q.716 (3/93) Signalling Connection Control Part (SCCP) performance.
- [13] IETF RFC 791 (9/1981): Internet Protocol.
- [14] IETF RFC 1483 (7/1993): "Multi protocol Encapsulation over ATM Adaptation Layer 5".
- [15] IETF RFC 2225 (4/1998): "Classical IP and ARP over ATM".
- ~~[16] IETF RFC 768 (8/1980): "User Datagram Protocol".~~
- [17] R. Stewart et al, "Simple Control Transmission Protocol", draft-ietf-sigtran-sctp-v60.txt ([IESG Last Call Version](#) ~~Work In Progress~~), IETF, ~~February 2000~~ ~~September 1999~~.
- [18] G. Sidebottom et al, "SS7 MTP3 – User Adaptation Layer", draft-ietf-sigtran-m3ua-01.txt ([Work In Progress](#)), IETF, ~~February 2000~~ "SS7 ISUP Tunnelling", draft-ietf-sigtran-itun-00.txt ([Work In Progress](#)), IETF, ~~June 1999~~.
- [19] ITU-T Rec. I.630 (2/99) ATM Protection Switching.

---

## 5 RNSAP Signalling Bearer

### 5.1 Introduction

This chapter specifies the Signaling Bearer protocol stack that supports the RNSAP signaling protocol.

The following requirements on the RNSAP signalling bearer can be stated:

- Provide reliable transfer of control plane signalling messages in both connectionless mode and connection-oriented mode;
- Provide separate independent connections for distinguishing transactions with individual Ues;
- Supervise the 'UE connections' and provide connection status information to the Upper Layers for individual Ues;
- Provide networking and routing functions;
- Provide redundancy in the signalling network;
- Provide load sharing.

### 5.2 Signalling Bearer

This chapter refers to specifications of the Signalling Bearer for the Radio Network Layer protocols. As shown in figure 3, the standard allows operators to choose one out of two protocol to suites for transport of SCCP messages.



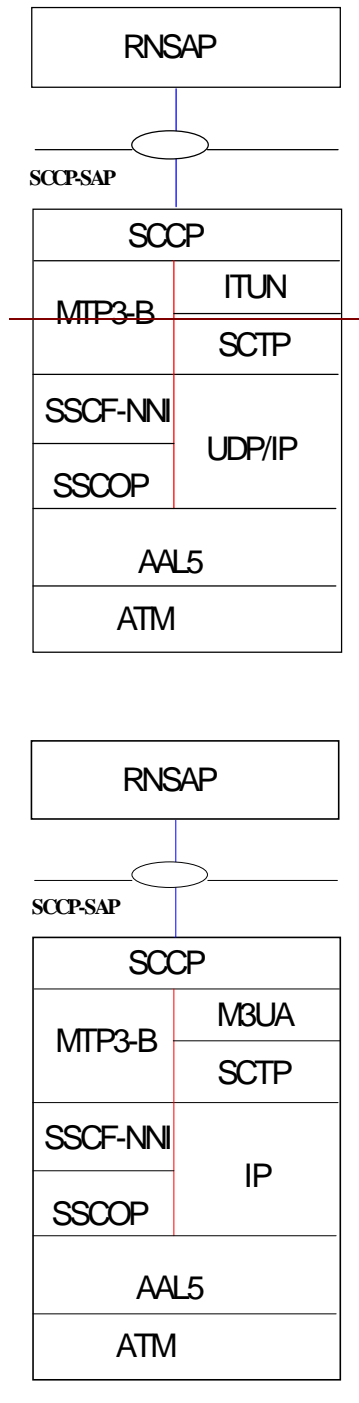

**Figure 3: Signalling bearer for RNSAP**

1. **SCCP** [7] provides connectionless service, class 0, connection oriented service, class 2, separation of the connections mobile by mobile basis on the connection oriented link and establishment of a connection oriented link mobile by mobile basis.
2. **MTP3-B** [4] provides message routing, discrimination and distribution (for point-to-point link only), signalling link management load sharing and changeover/back between link within one link-set. The need for multiple link-sets is precluded.
3. **SAAL-NNI** [1] consists of the following sub-layers: - **SSCF** [3], - **SSCOP** [2] and - **AAL5** [6]. The SSCF maps the requirements of the layer above to the requirements of SSCOP. Also SAAL connection management, link status and remote processor status mechanisms are provided. SSCOP provides mechanisms for the establishment

and release of connections and the reliable exchange of signalling information between signalling entities. Adapts the upper layer protocol to the requirements of the Lower ATM cells.

4. **ATM** [5]
5. **SCTP** refers to the Simple Control Transmission Protocol [17] developed by the Sigtran working group of the IETF for the purposes of transporting various signalling protocols over IP networks. ~~IPUNM3UA~~ refers to the SCCP adaptation layer "SS7 MTP3 – User Adaptation Layer/ISUP Tunnelling" [18] also developed by the Sigtran working group of the IETF.
6. ~~UDP [16]/~~**IP** [13] over ATM ~~are~~is defined in [14] and [15].

### 5.3 Services Provided by the Signalling Bearer

When considering the requirements that the upper layers, i.e. RNSAP, have on the Signalling Bearer, there are a number of services it has to provide and a number of functions to perform. These numbers of services that the signalling bearer shall provide, to the upper layers, are stated in the reference [7] to [12].