

**TSG-RAN Meeting #7**  
**Madrid, Spain, 13 – 15 March 2000**

**RP-000061**

**Title:** Agreed CRs to TS 25.212 (1)

**Source:** TSG-RAN WG1

**Agenda item:** 6.1.3

No.	Doc #	Spec	CR	Rev	Subject	Cat	Versio	Versio
1	R1-000278	25.212	025	2	CR for parity bit attachment to 0 bit transport	B	3.1.1	3.2.0
2	R1-000241	25.212	029	1	Limitations of blind transport format detection	F	3.1.1	3.2.0
3	R1-000116	25.212	034	1	Clarification of fixed position rate matching	F	3.1.1	3.2.0
4	R1-000170	25.212	035	1	Clarification of DL compressed mode	D	3.1.1	3.2.0
5	R1-000264	25.212	036	-	Reconfiguration of TFCS	F	3.1.1	3.2.0
6	R1-000249	25.212	037	1	Removal of fixed gap position in 25.212	C	3.1.1	3.2.0
7	R1-000347	25.212	038	2	Definition clarification for TS 25.212	D	3.1.1	3.2.0
8	R1-000123	25.212	039	1	Clarification on TFCI coding input	F	3.1.1	3.2.0
9	R1-000242	25.212	041	2	Correction of UL compressed mode by higher	F	3.1.1	3.2.0
10	R1-000418	25.212	042	5	Downlink Compressed Mode by puncturing	C	3.1.1	3.2.0
11	R1-000160	25.212	044	-	Modification of Turbo code internal interleaver	B	3.1.1	3.2.0
12	R1-000211	25.212	045	-	Editorial corrections	F	3.1.1	3.2.0
13	R1-000218	25.212	046	-	SF/2 method: DTX insertion after 2nd interleaver	F	3.1.1	3.2.0
14	R1-000346	25.212	047	1	TFCI coding for FDD	F	3.1.1	3.2.0
15	R1-000238	25.212	048	-	Mapping of TFCI in downlink compressed mode	F	3.1.1	3.2.0
16	R1-000243	25.212	049	-	Editorial changes to Annex A	D	3.1.1	3.2.0
17	R1-000244	25.212	050	-	Removal of rate matching attribute setting for	F	3.1.1	3.2.0
18	R1-000255	25.212	052	-	Padding Function for Turbo coding of small blocks	B	3.1.1	3.2.0
19	R1-000425	25.212	055	2	Clarifications relating to DSCH	F	3.1.1	3.2.0
20	R1-000281	25.212	056	-	Editorial modification of uplink shifting parameter	D	3.1.1	3.2.0



## 4.2.1 Error detection

Error detection is provided on transport blocks through a Cyclic Redundancy Check. The CRC is 24, 16, 12, 8 or 0 bits and it is signalled from higher layers what CRC length that should be used for each TrCH.

### 4.2.1.1 CRC Calculation

The entire transport block is used to calculate the CRC parity bits for each transport block. The parity bits are generated by one of the following cyclic generator polynomials:

$$g_{\text{CRC24}}(D) = D^{24} + D^{23} + D^6 + D^5 + D + 1$$

$$g_{\text{CRC16}}(D) = D^{16} + D^{12} + D^5 + 1$$

$$g_{\text{CRC12}}(D) = D^{12} + D^{11} + D^3 + D^2 + D + 1$$

$$g_{\text{CRC8}}(D) = D^8 + D^7 + D^4 + D^3 + D + 1$$

Denote the bits in a transport block delivered to layer 1 by  $a_{im1}, a_{im2}, a_{im3}, \dots, a_{imA_i}$ , and the parity bits by

$p_{im1}, p_{im2}, p_{im3}, \dots, p_{imL_i}$ .  $A_i$  is the length of a transport block of TrCH  $i$ ,  $m$  is the transport block number, and  $L_i$  is 24, 16, 12, 8, or 0 depending on what is signalled from higher layers.

The encoding is performed in a systematic form, which means that in GF(2), the polynomial

$$a_{im1}D^{A_i+23} + a_{im2}D^{A_i+22} + \dots + a_{imA_i}D^{24} + p_{im1}D^{23} + p_{im2}D^{22} + \dots + p_{im23}D^1 + p_{im24}$$

yields a remainder equal to 0 when divided by  $g_{\text{CRC24}}(D)$ , polynomial

$$a_{im1}D^{A_i+15} + a_{im2}D^{A_i+14} + \dots + a_{imA_i}D^{16} + p_{im1}D^{15} + p_{im2}D^{14} + \dots + p_{im15}D^1 + p_{im16}$$

yields a remainder equal to 0 when divided by  $g_{\text{CRC16}}(D)$ , polynomial

$$a_{im1}D^{A_i+11} + a_{im2}D^{A_i+10} + \dots + a_{imA_i}D^{12} + p_{im1}D^{11} + p_{im2}D^{10} + \dots + p_{im11}D^1 + p_{im12}$$

yields a remainder equal to 0 when divided by  $g_{\text{CRC12}}(D)$  and polynomial

$$a_{im1}D^{A_i+7} + a_{im2}D^{A_i+6} + \dots + a_{imA_i}D^8 + p_{im1}D^7 + p_{im2}D^6 + \dots + p_{im7}D^1 + p_{im8}$$

yields a remainder equal to 0 when divided by  $g_{\text{CRC8}}(D)$ .

If no transport blocks are input to the CRC calculation ( $M_i = 0$ ), no CRC attachment shall be done. If transport blocks are input to the CRC calculation ( $M_i \neq 0$ ) and the size of a transport block is zero ( $A_i = 0$ ), CRC shall be attached, i.e. all parity bits equal to zero.

#### 4.2.1.1.1 Relation between input and output of the Cyclic Redundancy Check

The bits after CRC attachment are denoted by  $b_{im1}, b_{im2}, b_{im3}, \dots, b_{imB_i}$ , where  $B_i = A_i + L_i$ . The relation between  $a_{imk}$  and  $b_{imk}$  is:

$$b_{imk} = a_{imk} \quad k = 1, 2, 3, \dots, A_i$$

$$b_{imk} = p_{im(L_i+1-(k-A_i))} \quad k = A_i + 1, A_i + 2, A_i + 3, \dots, A_i + L_i$$

## 4.2.2 Transport block concatenation and code block segmentation

All transport blocks in a TTI are serially concatenated. If the number of bits in a TTI is larger than  $Z$ , the maximum size of a code block in question, then code block segmentation is performed after the concatenation of the transport blocks. The maximum size of the code blocks depends on whether convolutional coding, turbo coding or no coding is used for the TrCH.



## 4.3 Transport format detection

Transport format detection can be performed both with and without Transport Format Combination Indicator (TFCI). If a TFCI is transmitted, the receiver detects the transport format combination from the TFCI. When no TFCI is transmitted, so-called blind transport format detection may be used, i.e. the receiver side detects the transport format combination using some information, e.g. received power ratio of DPDCH to DPCCH, CRC check results.

~~For uplink, the blind transport format detection is an operator option. For downlink, the blind transport format detection can be applied with convolutional coding, the maximum number of different transport formats and maximum data rates allowed shall be specified. If the transport format set of a TrCH  $i$  contains more than one transport format, the transport format can be detected according to one of the following methods:~~

- TFCI based detection: This method is applicable when the transport format combination is signalled using the TFCI field.
- Explicit blind detection: This method typically consists of detecting the TF of TrCH  $i$  by use of channel decoding and CRC check.
- Guided detection: This method is applicable when there is at least one other TrCH  $i'$ , hereafter called guiding TrCH, such that:
  - the guiding TrCH has the same TTI duration as the TrCH under consideration, i.e.  $F_{i'} = F_i$
  - different TFs of the TrCH under consideration correspond to different TFs of the guiding TrCH
  - explicit blind detection is used on the guiding TrCH.

If the transport format set for a TrCH  $i$  contains one transport format only, no transport format detection needs to be performed for this TrCH.

For uplink, blind transport format detection is a network controlled option. For downlink, the UE shall be capable of performing blind transport format detection, if certain restrictions on the configured transport channels are fulfilled.

### 4.3.1 Blind transport format detection

When no TFCI is available then explicit blind detection or guided detection shall be performed on all TrCHs within the CCTrCH that have more than one transport format. The UE shall only be required to support blind transport format detection if all of the following restrictions are fulfilled:

1. The number of CCTrCH bits received per radio frame is 600 or less.
2. The number of transport format combinations of the CCTrCH is 64 or less.
3. Fixed positions of the transport channels is used on the CCTrCH to be detected.
4. Convolutional coding is used on all explicitly detected TrCHs.
5. CRC is appended to all transport blocks on all explicitly detected TrCHs.
6. The number of explicitly detected TrCHs is 3 or less.
7. For all explicitly detected TrCHs  $i$ , the number of code blocks in one TTI ( $C_i$ ) shall not exceed 1.
8. The sum of the transport format set sizes of all explicitly detected TrCHs, is 16 or less. The transport format set size is defined as the number of transport formats within the transport format set.
9. There is at least one TrCH that can be used as the guiding transport channel for all transport channels using guided detection.

Examples of blind transport format detection methods are given in Annex A.

#### 4.3.2 ~~Explicit~~ Transport format detection based on TFCI

~~If a TFCI is available, then TFCI based detection shall be applicable to all TrCHs within the CCTrCH. The Transport Format Combination Indicator (TFCI) informs the receiver of about the transport format combination of the CCTrCHs. As soon as the TFCI is detected, the transport format combination, and hence the transport formats of the individual transport channels' transport formats are known, and decoding of the transport channels can be performed.~~



## 3.2 Symbols

For the purposes of the present document, the following symbols apply:

$\lceil x \rceil$  round towards  $\infty$ , i.e. integer such that  $x \leq \lceil x \rceil < x+1$   
 $\lfloor x \rfloor$  round towards  $-\infty$ , i.e. integer such that  $x-1 < \lfloor x \rfloor \leq x$   
 $|x|$  absolute value of  $x$

$\text{sgn}(x)$  signum function, i.e.  $\text{sgn}(x) = \begin{cases} 1; & x \geq 0 \\ -1; & x < 0 \end{cases}$

$N_{first}$  The first slot in the  $TG$ .

$N_{last}$  The last slot in the  $TG$ .  $N_{last}$  is either a slot in the same radio frame as  $N_{first}$  or a slot in the radio frame immediately following the slot that contains  $N_{first}$ .

Unless otherwise is explicitly stated when the symbol is used, the meaning of the following symbols is:

$i$  TrCH number  
 $j$  TFC number  
 $k$  Bit number  
 $l$  TF number  
 $m$  Transport block number  
 $n_i$  Radio frame number of TrCH  $i$ .  
 $p$  PhCH number  
 $r$  Code block number  
 $I$  Number of TrCHs in a CCTrCH.  
 $C_i$  Number of code blocks in one TTI of TrCH  $i$ .  
 $F_i$  Number of radio frames in one TTI of TrCH  $i$ .  
 $M_i$  Number of transport blocks in one TTI of TrCH  $i$ .  
 $P$  Number of PhCHs used for one CCTrCH.  
 $PL$  Puncturing Limit for the uplink. Signalled from higher layers  
 $RM_i$  Rate Matching attribute for TrCH  $i$ . Signalled from higher layers.

Temporary variables, i.e. variables used in several (sub)sections with different meaning.

$x, X$   
 $y, Y$   
 $z, Z$



## 4.2.7.2.1.1 Uncoded and convolutionally encoded TrCHs

$$\Delta N_i = \Delta N_{max}$$

$$a=2$$

$$N_{max} = \max_{l \in TFS(i)} N_{il}^{TTI}$$

For each transmission time interval of TrCH  $i$  with TF  $l$ , the rate-matching pattern is calculated with the algorithm in section 4.2.7.5. The following parameters are used as input:

$$X_i = N_{il}^{TTI}$$

$$e_{ini} = 1$$

$$e_{plus} = a \cdot N_{max}$$

$$e_{minus} = a \cdot |\Delta N_i|$$

Puncturing if  $\Delta N_i < 0$ , repetition otherwise. The values of  $\Delta N_{i,l}^{TTI}$  may be computed by counting repetitions or puncturing when the algorithm of section 4.2.7.5 is run. The resulting values of  $\Delta N_{i,l}^{TTI}$  can be represented with following expression.

$$\Delta N_{i,l}^{TTI} = \left\lfloor \frac{|\Delta N_{max}| \times X_i}{N_{max}} \right\rfloor \times \text{sgn}(\Delta N_{max})$$

## 4.2.7.2.1.2 Turbo encoded TrCHs

If repetition is to be performed on turbo encoded TrCHs, i.e.  $\Delta N_{max} > 0$ , the parameters in section 4.2.7.2.1.1 are used.

If puncturing is to be performed, the parameters below shall be used. Index  $b$  is used to indicate systematic ( $b=1$ ), 1<sup>st</sup> parity ( $b=2$ ), and 2<sup>nd</sup> parity bit ( $b=3$ ).

$$a=2 \text{ when } b=2$$

$$a=1 \text{ when } b=3$$

The bits indicated by  $b=1$  shall not be punctured.

$$\Delta N_i = \begin{cases} \lfloor \Delta N_{max} / 2 \rfloor, & b = 2 \\ \lceil \Delta N_{max} / 2 \rceil, & b = 3 \end{cases}$$

$$N_{max} = \max_{l \in TFS(i)} (N_{il}^{TTI} / 3)$$

For each transmission time interval of TrCH  $i$  with TF  $l$ , the rate-matching pattern is calculated with the algorithm in section 4.2.7.5. The following parameters are used as input:

$$X_i = N_{il}^{TTI} / 3$$

$$e_{ini} = N_{max}$$

$$e_{plus} = a \cdot N_{max}$$

$$e_{\min us} = a \cdot |\Delta N_i|$$

The values of  $\Delta N_{i,l}^{TTI}$  may be computed by counting ~~repetitions or~~ puncturing when the algorithm of section 4.2.7.5 is run. The resulting values of  $\Delta N_{i,l}^{TTI}$  can be represented with following expression.

$$\Delta N_{i,l}^{TTI} = \left[ \frac{\lfloor \lfloor \Delta N_{max} / 2 \rfloor \rfloor \times X_i + 0.5}{N_{max}} \right] - \left[ \frac{\lceil \lceil \Delta N_{max} / 2 \rceil \rceil \times X_i}{N_{max}} \right]$$

In the above equation, the first term of the right hand side represents the amount of puncturing for  $b=2$  and the second term represents the amount of puncturing for  $b=3$ .



## 3.2 Symbols

For the purposes of the present document, the following symbols apply:

$\lceil x \rceil$	round towards $\infty$ , i.e. integer such that $x \leq \lceil x \rceil < x+1$
$\lfloor x \rfloor$	round towards $-\infty$ , i.e. integer such that $x-1 < \lfloor x \rfloor \leq x$
$ x $	absolute value of $x$

$N_{first}$	The first slot in the <i>TG</i> .
$N_{last}$	The last slot in the <i>TG</i> . <del><math>N_{last}</math> is either a slot in the same radio frame as <math>N_{first}</math> or a slot in the radio frame immediately following the slot that contains <math>N_{first}</math>.</del>

Unless otherwise is explicitly stated when the symbol is used, the meaning of the following symbols is:

$i$	TrCH number
$j$	TFC number
$k$	Bit number
$l$	TF number
$m$	Transport block number
$n_i$	Radio frame number of TrCH $i$ .
$p$	PhCH number
$r$	Code block number
$I$	Number of TrCHs in a CCTrCH.
$C_i$	Number of code blocks in one TTI of TrCH $i$ .
$F_i$	Number of radio frames in one TTI of TrCH $i$ .
$M_i$	Number of transport blocks in one TTI of TrCH $i$ .
$N_{data,j}$	<u>Number of data bits that are available for the CCTrCH in a radio frame with TFC <math>j</math>.</u>
$N_{data,j}^{cm}$	<u>Number of data bits that are available for the CCTrCH in a compressed radio frame with TFC <math>j</math>.</u>
$P$	Number of PhCHs used for one CCTrCH.
$PL$	Puncturing Limit for the uplink. Signalled from higher layers
$RM_i$	Rate Matching attribute for TrCH $i$ . Signalled from higher layers.

Temporary variables, i.e. variables used in several (sub)sections with different meaning.

$x, X$
$y, Y$
$z, Z$

## 4.2 Transport-channel coding/multiplexing

Data arrives to the coding/multiplexing unit in form of transport block sets once every transmission time interval. The transmission time interval is transport-channel specific from the set {10 ms, 20 ms, 40 ms, 80 ms}.

The following coding/multiplexing steps can be identified:

- Add CRC to each transport block (see section 4.2.1)
- Transport block concatenation and code block segmentation (see section 4.2.2)
- Channel coding (see section 4.2.3)
- Rate matching (see section 4.2.7)
- Insertion of discontinuous transmission (DTX) indication bits (see section 4.2.9)
- Interleaving (two steps, see sections 4.2.4 and 4.2.11)
- Radio frame segmentation (see section 4.2.6)
- Multiplexing of transport channels (see section 4.2.8)
- Physical channel segmentation (see section 4.2.10)
- Mapping to physical channels (see section 4.2.12)

The coding/multiplexing steps for uplink and downlink are shown in figure 1 and figure 2 respectively.

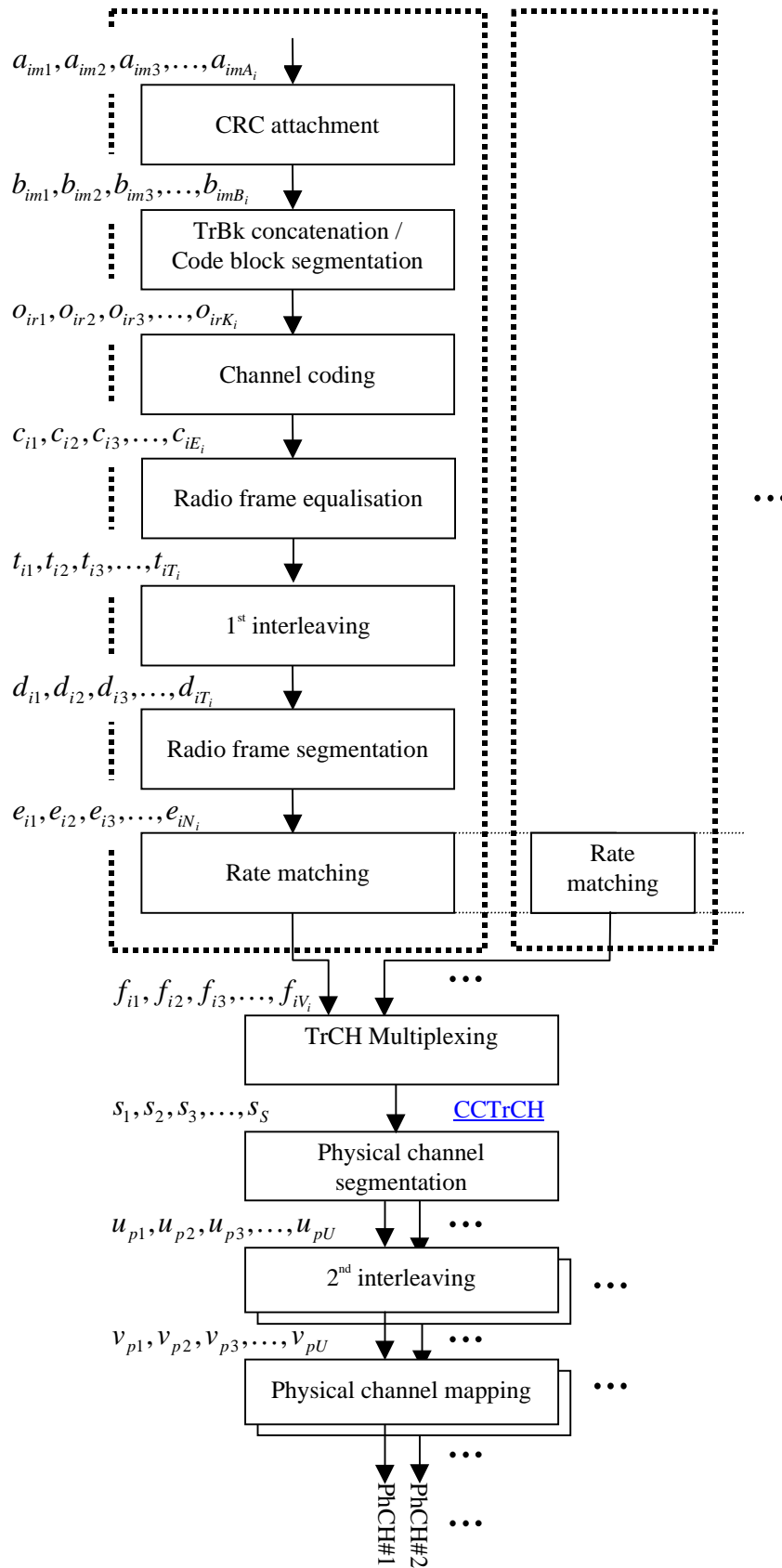
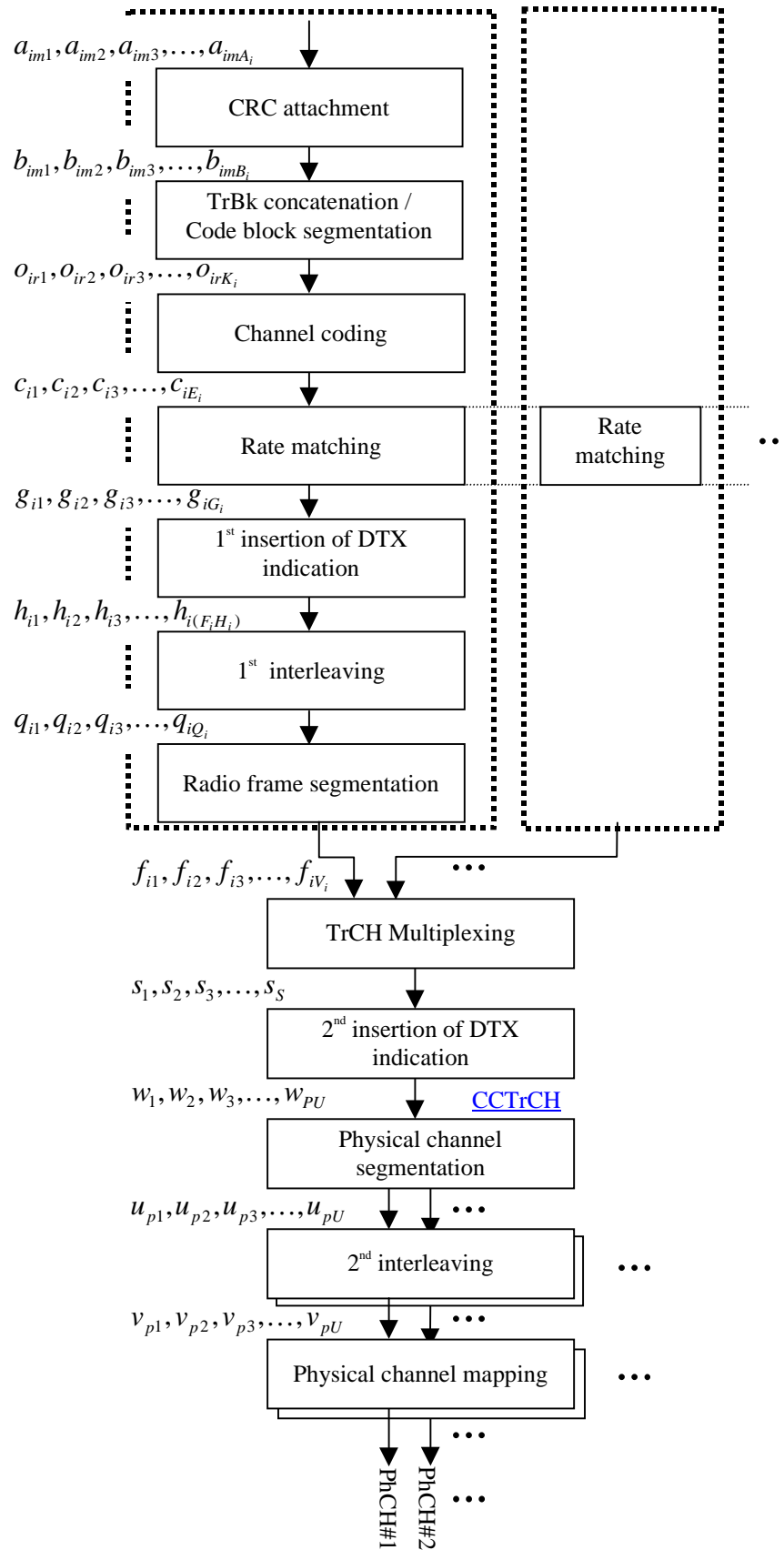

Figure 1: Transport channel multiplexing structure for uplink



**Figure 2: Transport channel multiplexing structure for downlink**

The single output data stream from the TrCH multiplexing, including DTX indication bits in downlink, is denoted Coded Composite Transport Channel (CCTrCH). A CCTrCH can be mapped to one or several physical channels.

#### 4.2.7.2 Determination of rate matching parameters in downlink

For downlink  $N_{data,j}$  does not depend on the transport format combination  $j$ .  $N_{data,*}$  is given by the channelization code(s) assigned by higher layers. Denote the number of physical channels used for the CCTrCH by  $P$ .  $N_{data,*}$  is the number of bits available to the CCTrCH in one radio frame and defined as  $N_{data,*} = P(15N_{data1} + 15N_{data2})$ , where  $N_{data1}$  and  $N_{data2}$  are defined in [2]. Note that contrary to the uplink, the same rate matching patterns are used in normal and compressed mode by spreading factor reduction or higher layer scheduling.



#### 4.2.9.2 2<sup>nd</sup> insertion of DTX indication bits

The DTX indication bits inserted in this step shall be placed at the end of the radio frame. Note that the DTX will be distributed over all slots after 2<sup>nd</sup> interleaving.

The bits input to the DTX insertion block are denoted by  $s_1, s_2, s_3, \dots, s_S$ , where  $S$  is the number of bits from TrCH multiplexing. The number of PhCHs is denoted by  $P$  and the number of bits in one radio frame, including DTX

indication bits, for each PhCH by  $U$ . In normal mode  $U = \frac{N_{data,*}}{P} = 15N_{data1} + 15N_{data2}$  ~~The number of available bits~~

on the PhCH is denoted by  $N_{data,*}$  and  $N_{data,*} = 15N_{data1} + 15N_{data2}$ , where  $N_{data1}$  and  $N_{data2}$  are defined in [25.211]. In normal mode  $U = N_{data,*}$  ~~In compressed mode, additional DTX shall be inserted if the transmission time reduction method does not exactly create a transmission gap of the desired TGL. The number of bits available to the CCTrCH in one radio~~

frame in compressed mode is denoted by  $N_{data,*}^{cm}$  and  $U = \frac{N_{data,*}^{cm}}{P}$   ~~$N_{data,*}$  is changed from the value in normal mode. The~~

exact value of  $N_{data,*}^{cm}$   ~~$N_{data,*}$~~  is dependent on the TGL and the transmission time reduction method, which are signalled

from higher layers. It can be calculated as  $N_{data,*}^{cm} = N'_{data,*} - N_{TGL}$ , where  $N'_{data,*} = P(15N'_{data1} + 15N'_{data2})$  ~~.~~

$N'_{data1}$  and  $N'_{data2}$  are the number of bits in the data fields of a slot for slot format A or B as defined in [2].  $N_{TGL}$  is the ~~the~~  
number of bits that are located within the transmission gap ~~is denoted  $N_{TGL}$~~  and defined as:

$$N_{TGL} = \begin{cases} \frac{TGL}{15} N'_{data,*} \frac{TGL}{15} N_{data}, & \text{if } N_{first} + TGL \leq 15 \\ \frac{15 - N_{first}}{15} N'_{data,*} \frac{15 - N_{first}}{15} N_{data}, & \text{in first frame if } N_{first} + TGL > 15 \\ \frac{TGL - (15 - N_{first})}{15} N'_{data,*} \frac{TGL - (15 - N_{first})}{15} N_{data}, & \text{in second frame if } N_{first} + TGL > 15 \end{cases}$$

$N_{first}$  and  $TGL$  are defined in Section 4.4.

~~In compressed mode  $U = N_{data,*} - N_{TGL}$ .~~

The bits output from the DTX insertion block are denoted by  $w_1, w_2, w_3, \dots, w_{(PU)}$ . Note that these bits are threevalued. They are defined by the following relations:

$$w_k = s_k \quad k = 1, 2, 3, \dots, S$$

$$w_k = \delta \quad k = S+1, S+2, S+3, \dots, PU$$

where DTX indication bits are denoted by  $\delta$ . Here  $s_k \in \{0,1\}$  and  $\delta \notin \{0,1\}$ .

# CHANGE REQUEST

*Please see embedded help file at the bottom of this page for instructions on how to fill in this form correctly.*

**25.212 CR 036**

Current Version: **3.1.0**

GSM (AA.BB) or 3G (AA.BBB) specification number ↑

↑ CR number as allocated by MCC support team

For submission to: **TSG-RAN #7**  
list expected approval meeting # here ↑

for approval   
for information

strategic   
non-strategic  (for SMG use only)

Form: CR cover sheet, version 2 for 3GPP and SMG The latest version of this form is available from: ftp://ftp.3gpp.org/Information/CR-Form-v2.doc

**Proposed change affects:**

(at least one should be marked with an X)

(U)SIM  ME  UTRAN / Radio  Core Network

**Source:**

**TSG RAN WG1**

**Date:**

**2000-01-11**

**Subject:**

**Reconfiguration of TFCS**

**Work item:**

**Category:**

(only one category shall be marked with an X)

F Correction   
A Corresponds to a correction in an earlier release   
B Addition of feature   
C Functional modification of feature   
D Editorial modification

**Release:** Phase 2   
Release 96   
Release 97   
Release 98   
Release 99   
Release 00

**Reason for change:**

The current text in 4.2.14 does not specifically describe the case of TFCS reconfiguration where a transport channel is removed from the multiplex

**Clauses affected:**

4.2.14 "Multiplexing of different transport channels into one CCTrCH, and mapping of one CCTrCH onto physical channels"

**Other specs affected:**

Other 3G core specifications  → List of CRs:  
Other GSM core specifications  → List of CRs:  
MS test specifications  → List of CRs:  
BSS test specifications  → List of CRs:  
O&M specifications  → List of CRs:

**Other comments:**



help.doc

<----- double-click here for help and instructions on how to create a CR.

## 4.2.14 Multiplexing of different transport channels into one CCTrCH, and mapping of one CCTrCH onto physical channels

The following rules shall apply to the different transport channels which are part of the same CCTrCH:

- 1) Transport channels multiplexed into one CCTrCh shall have co-ordinated timings. When the TFCS of a CCTrCH is changed because ~~one or more~~ transport channels ~~is~~ ~~are~~ added to the CCTrCH or reconfigured within the CCTrCH, ~~or removed from the CCTrCH, the change may only be made at the TTI of transport channel i may only start of a radio frames~~ with CFN fulfilling the relation

$$\text{CFN}_i \bmod F_{\max} = 0,$$

where  $F_{\max}$  denotes the maximum number of radio frames within the transmission time intervals of all transport channels which are multiplexed into the same CCTrCH, including ~~any~~ transport channels ~~i~~ which ~~are~~ ~~is~~ added, ~~or reconfigured or have been removed~~, and  $\text{CFN}_i$  denotes the connection frame number of the first radio frame ~~of the changed CCTrCH, within the transmission time interval of transport channel i.~~

After addition or reconfiguration of a transport channel  $i$  within a CCTrCH, the TTI of transport channel  $i$  may only start in radio frames with CFN fulfilling the relation

$$\text{CFN}_i \bmod F_i = 0.$$

- 2) Only transport channels with the same active set can be mapped onto the same CCTrCH.
- 3) Different CCTrCHs cannot be mapped onto the same PhCH.
- 4) One CCTrCH shall be mapped onto one or several PhCHs. These physical channels shall all have the same SF.
- 5) Dedicated Transport channels and common transport channels cannot be multiplexed into the same CCTrCH
- 6) For the common transport channels, only the FACH and PCH may belong to the same CCTrCH

There are hence two types of CCTrCH

- 1) CCTrCH of dedicated type, corresponding to the result of coding and multiplexing of one or several DCHs.
- 2) CCTrCH of common type, corresponding to the result of the coding and multiplexing of a common channel, RACH in the uplink, DSCH, BCH, or FACH/PCH for the downlink.

### 4.2.14.1 Allowed CCTrCH combinations for one UE

#### 4.2.14.1.1 Allowed CCTrCH combinations on the uplink

A maximum of one CCTrCH is allowed for one UE on the uplink. It can be either

- 1) one CCTrCH of dedicated type
- 2) one CCTrCH of common type

#### 4.2.14.1.2 Allowed CCTrCH combinations on the downlink

The following CCTrCH combinations for one UE are allowed :

x CCTrCH of dedicated type + y CCTrCH of common type

The allowed combination of CCTrCHs of dedicated and common type are FFS.

NOTE 1: There is only one DPCCCH in the uplink, hence one TPC bits flow on the uplink to control possibly the different DPDCHs on the downlink, part of the same or several CCTrCHs.

NOTE 2: There is only one DPCCH in the downlink, even with multiple CCTrCHs. With multiple CCTrCHs, the DPCCH is transmitted on one of the physical channels of that CCTrCH which has the smallest SF among the multiple CCTrCHs. Thus there is only one TPC command flow and only one TFCI word in downlink even with multiple CCTrCHs.

**3GPP TSG RAN Meeting #7**  
**Madrid, Spain, 13-15 March 2000**

**Document R1-00-0249**

e.g. for 3GPP use the format TP-99xxx  
 or for SMG, use the format P-99-xxx

<h2 style="margin: 0;">CHANGE REQUEST</h2>		<i>Please see embedded help file at the bottom of this page for instructions on how to fill in this form correctly.</i>
<b>25.212</b>	<b>CR</b>	<b>037rev1</b>
		Current Version: <b>3.1.1</b>
<small>GSM (AA.BB) or 3G (AA.BBB) specification number ↑</small>		<small>↑ CR number as allocated by MCC support team</small>
For submission to: <b>RAN # 7</b> <small>list expected approval meeting # here ↑</small>	for approval for information	strategic non-strategic <span style="margin-left: 20px;"><small>(for SMG use only)</small></span>
	<input checked="" type="checkbox"/> <input type="checkbox"/>	<input type="checkbox"/> <input type="checkbox"/>

Form: CR cover sheet, version 2 for 3GPP and SMG    The latest version of this form is available from: <ftp://ftp.3gpp.org/Information/CR-Form-v2.doc>

**Proposed change affects:**    (U)SIM     ME     UTRAN / Radio     Core Network   
(at least one should be marked with an X)

**Source:**    TSG RAN WG1    **Date:**    04-Jan-2000

**Subject:**    Removal of fixed gap position in 25.212

**Work item:**    \_\_\_\_\_

<b>Category:</b>	F Correction <input type="checkbox"/> A Corresponds to a correction in an earlier release <input type="checkbox"/> B Addition of feature <input type="checkbox"/> C Functional modification of feature <input checked="" type="checkbox"/> D Editorial modification <input type="checkbox"/>	<b>Release:</b>	Phase 2 <input type="checkbox"/> Release 96 <input type="checkbox"/> Release 97 <input type="checkbox"/> Release 98 <input type="checkbox"/> Release 99 <input checked="" type="checkbox"/> Release 00 <input type="checkbox"/>
------------------	--	-----------------	--

(only one category shall be marked with an X)

**Reason for change:**    Fixed gap positions in compressed mode patterns are not needed as it can be expressed with flexible position parameters. UE complexity can be reduced by removing this option.

**Clauses affected:**    4.4, 4.4.1, 4.4.4, 4.4.4.1, 4.4.4.2, 4.4.4.3

<b>Other specs affected:</b>	Other 3G core specifications <input checked="" type="checkbox"/> Other GSM core specifications <input type="checkbox"/> MS test specifications <input type="checkbox"/> BSS test specifications <input type="checkbox"/> O&M specifications <input type="checkbox"/>	→ List of CRs: 25.215-033 → List of CRs: → List of CRs: → List of CRs: → List of CRs:
------------------------------	--	---

**Other comments:**    \_\_\_\_\_

<----- double-click here for help and instructions on how to create a CR.

Denote the number of bits available in the TFCI fields of one compressed radio frame by  $D$  and the number of bits in the TFCI field in a slot by  $N_{TFCI}$ . Denote by  $E$  the first bit to be repeated,  $E=N_{first}N_{TFCI}$ . If  $N_{last} \neq 14$ , then  $E$  corresponds to the number of the first TFCI bit in the slot directly after the TG. Denote the total number of TFCI bits to be transmitted by  $N_{tot}$ . If  $SF \geq 128$  then  $N_{tot} = 32$ , else  $N_{tot} = 128$ . The following relations then define the mapping:

$$d_k = b_{(k \bmod 32)}$$

where  $k = 0, 1, 2, \dots, \min(E, N_{tot})-1$  and, if  $E < N_{tot}$ ,

$$d_{k+D-N_{tot}} = b_{(k \bmod 32)}$$

where  $k = E, \dots, N_{tot} - 1$ .

DTX bits are sent on  $d_k$  where  $k = \min(E, N_{tot}), \dots, \min(E, N_{tot}) + D - N_{tot} - 1$ .

## 4.4 Compressed mode

In compressed mode, TGL slots from  $N_{first}$  to  $N_{last}$  are not used for transmission of data. As illustrated in figure 12, ~~which shows the example of fixed transmission gap position with single frame method,~~ the instantaneous transmit power is increased in the compressed frame in order to keep the quality (BER, FER, etc.) unaffected by the reduced processing gain. The amount of power increase depends on the transmission time reduction method (see section 4.4.3). What frames are compressed, are decided by the network. When in compressed mode, compressed frames can occur periodically, as illustrated in figure 12, or requested on demand. The rate and type of compressed frames is variable and depends on the environment and the measurement requirements.

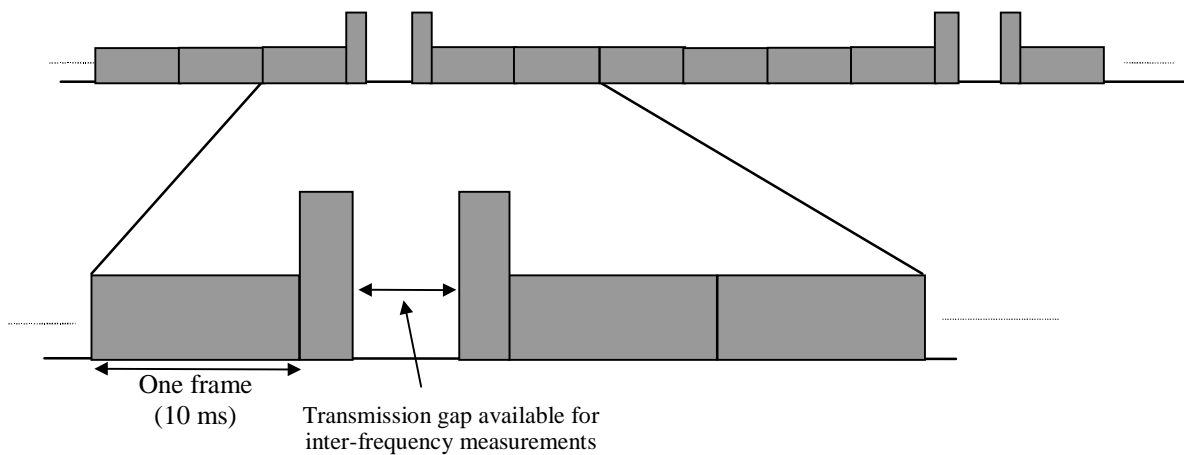

Figure 12: Compressed mode transmission

### 4.4.1 Frame structure in the uplink

The frame structure for uplink compressed mode is illustrated in figure 13.

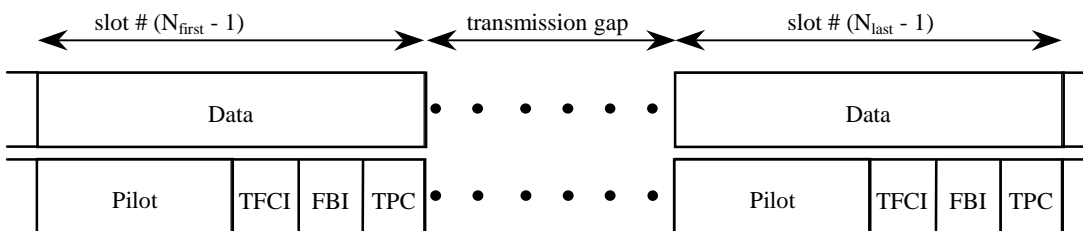
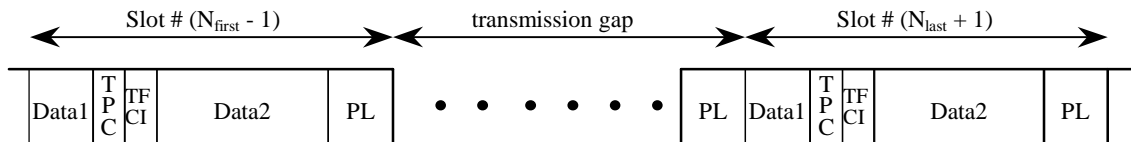

Figure 13: Frame structure in uplink compressed transmission

## 4.4.2 Frame structure types in the downlink

There are two different types of frame structures defined for downlink compressed mode. Type A maximises the transmission gap length and type B is optimised for power control.

- With frame structure of type A, the pilot field of the last slot in the transmission gap is transmitted. Transmission is turned off during the rest of the transmission gap (figure 14(a)).
- With frame structure of type B, the TPC field of the first slot in the transmission gap and the pilot field of the last slot in the transmission gap is transmitted. Transmission is turned off during the rest of the transmission gap (figure 14(b)).



(a) Frame structure type A

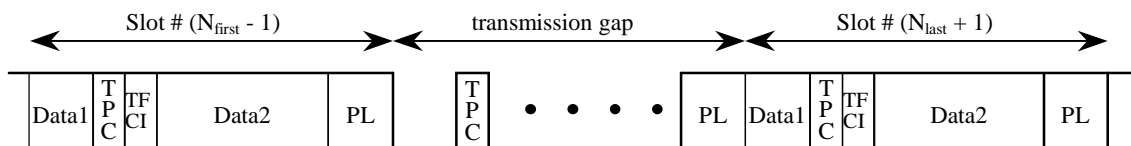

(b) Frame structure type B

Figure 14: Frame structure types in downlink compressed transmission

## 4.4.3 Transmission time reduction method

When in compressed mode, the information normally transmitted during a 10 ms frame is compressed in time. The mechanisms provided for achieving this are puncturing, reduction of the spreading factor by a factor of two, and higher layer scheduling. In the downlink, all methods are supported while compressed mode by puncturing is not used in the uplink. The maximum idle length is defined to be 7 slots per one 10 ms frame. The slot formats that are used in compressed mode are listed in [2].

### 4.4.3.1 Compressed mode by puncturing

During compressed mode, rate matching (puncturing) is applied for creating transmission gap in one frame. The algorithm for rate matching (puncturing) as described in section 4.2.7 is used.

### 4.4.3.2 Compressed mode by reducing the spreading factor by 2

During compressed mode, the spreading factor (SF) can be reduced by 2 during one radio frame to enable the transmission of the information bits in the remaining time slots of a compressed frame.

On the downlink, UTRAN can also order the UE to use a different scrambling code in compressed mode than in normal mode. If the UE is ordered to use a different scrambling code in compressed mode, then there is a one-to-one mapping between the scrambling code used in normal mode and the one used in compressed mode, as described in TS 25.213[3] section 5.2.1.

### 4.4.3.3 Compressed mode by higher layer scheduling

Compressed mode can be obtained by higher layer scheduling. Higher layers then set restrictions so that only a subset of the allowed TFCs are used in compressed mode. The maximum number of bits that will be delivered to the physical layer during the compressed radio frame is then known and a transmission gap can be generated.

### 4.4.4 Transmission gap position

Transmission gaps can be placed at ~~both fixed position and adjustable-different~~ positions as shown in figures 15 and 16 for each purpose such as interfrequency power measurement, acquisition of control channel of other system/carrier, and actual handover operation.

#### 4.4.4.1 ~~Fixed transmission gap position~~

~~The transmission gaps can be placed onto fixed positions.~~

When using single frame method, the ~~fixed~~ transmission gap is located within the compressed frame depending on the transmission gap length (TGL) as shown in figure 15 (1). When using double frame method, the ~~fixed~~ transmission gap is located on the center of two connected frames as shown in figure 15 (2).

~~Table 9 shows the parameters for the fixed transmission gap position case.~~

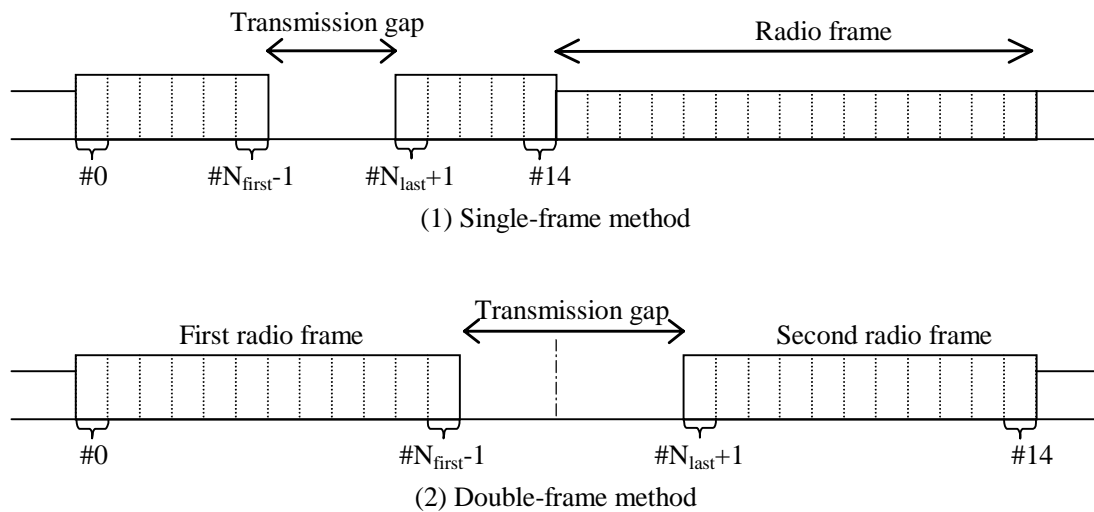

Figure 15: ~~Fixed t~~Transmission gap position

Table 9: Parameters for fixed transmission gap position

TGL (slot)	Single-frame method		Double-frame method	
	N <sub>first</sub>	N <sub>last</sub>	N <sub>first</sub>	N <sub>last</sub>
3	7	9	14 in first frame	1 in second frame
4	6	9	13 in first frame	1 in second frame
7	6	12	12 in first frame	3 in second frame
10	N.A.	N.A.	10 in first frame	4 in second frame
14	N.A.	N.A.	8 in first frame	6 in second frame

#### 4.4.4.2 ~~Adjustable transmission gap position~~

~~Position of transmission gaps can be adjustable/relocatable for some purpose e.g. data acquisition on certain position as shown in figure 16.~~ Parameters of the ~~adjustable~~ transmission gap positions are calculated as follows:

TGL is the number of consecutive idle slots during the compressed mode transmission gap,

$$TGL = 3, 4, \underline{5}, 7, 10, 14$$

N<sub>first</sub> specifies the starting slot of the consecutive idle slots,



$$N_{\text{first}} = 0, 1, 2, 3, \dots, 14.$$

$N_{\text{last}}$  shows the number of the final idle slot and is calculated as follows;

If  $N_{\text{first}} + \text{TGL} \leq 15$ , then  $N_{\text{last}} = N_{\text{first}} + \text{TGL} - 1$  ( in the same frame ),

If  $N_{\text{first}} + \text{TGL} > 15$ , then  $N_{\text{last}} = (N_{\text{first}} + \text{TGL} - 1) \bmod 15$  ( in the next frame ).

When the transmission gap spans two consecutive radio frames,  $N_{\text{first}}$  and TGL must be chosen so that at least 8 slots in each radio frame are transmitted.

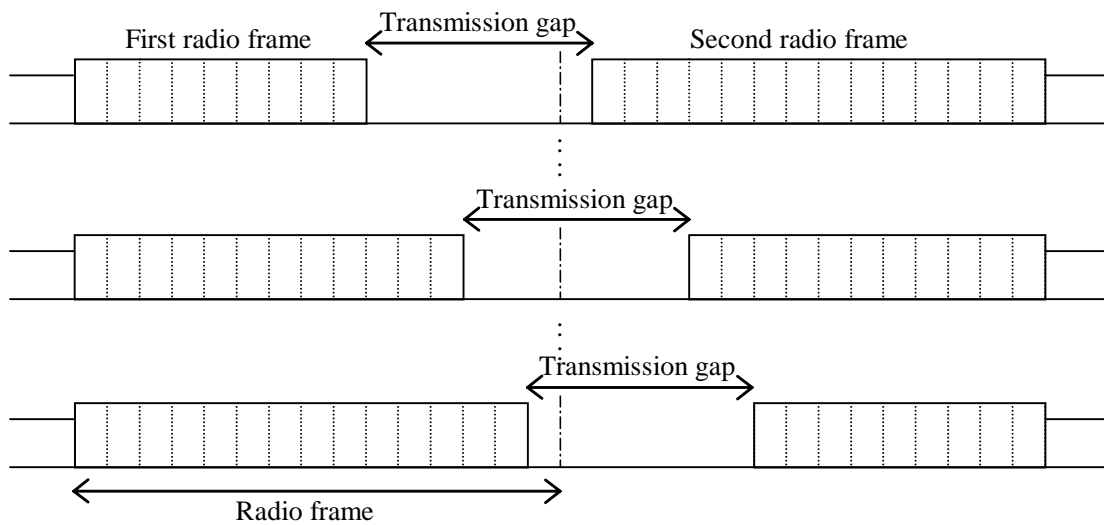
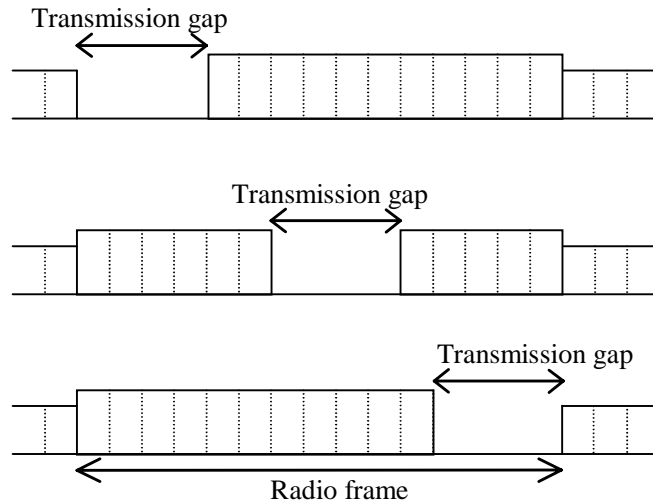

**Figure 16: Adjustable transmission gap lengths-positions with different  $N_{\text{first}}$**

#### 4.4.54.3 Parameters for downlink compressed mode

Table 10 shows the detailed parameters for each transmission gap length for the different transmission time reduction methods.

Table 10: Parameters for compressed mode

TGL	Frame Type	Adjustable /fixed gap position	Spreading Factor	Idle length [ms]	Transmission time Reduction method	Idle frame Combining
3	A	Adjustable Or Fixed	512 - 4	1.73-1.99	Puncturing, Spreading factor <del>reduction-division</del> by 2 or Higher layer scheduling	(S) (D) =(1,2), <u>or</u> , (2,1)
	B		256 - 4	1.60-1.86		
4	A		512 - 4	2.40-2.66		(S) (D) =(1,3), <u>(2,2)</u> , <u>or</u> , (3,1)
	B		256 - 4	2.27-2.53		
<u>5</u>	<u>A</u>		<u>512 - 4</u>	<u>3.07-3.33</u>		(S) (D) = (1,4), <u>(2,3)</u> , (3, 2) or <u>(4,1)</u>
	<u>B</u>		<u>256 - 4</u>	<u>2.94-3.20</u>		
7	A		512 - 4	4.40-4.66		(S) (D)=(1,6), <u>(2,5)</u> , <u>(3,4)</u> , <u>(4,3)</u> , <u>(5,2)</u> <u>or</u> , (6,1)
	B		256 - 4	4.27-4.53		
10	A		512 - 4	6.40-6.66		(D)=(3,7), <u>(4,6)</u> , <u>(5,5)</u> , <u>(6,4)</u> , <u>or</u> (7,3)
	B		256 - 4	6.27-6.53		
14	A	Fixed	512 - 4	9.07-9.33	(D) =(7,7)	
	B		256 - 4	8.93-9.19		

(S): Single-frame method as shown in figure 15 (1).

(D): Double-frame method as shown in figure 15 (2). (x,y) indicates x: the number of idle slots in the first frame, y: the number of idle slots in the second frame.

NOTE: Compressed mode by spreading factor reduction is not supported when SF=4 is used in normal mode.



**3GPP TSG RAN Meeting #7**  
**Madrid, Spain, 13-15 March 2000**

**Document R1-00-0347**

e.g. for 3GPP use the format TP-99xxx  
 or for SMG, use the format P-99-xxx

<b>CHANGE REQUEST</b>				Please see embedded help file at the bottom of this page for instructions on how to fill in this form correctly.
<b>25.212</b>	<b>CR</b>	<b>038rev2</b>	Current Version:	<b>3.1.0</b>
GSM (AA.BB) or 3G (AA.BBB) specification number ↑		↑ CR number as allocated by MCC support team		
For submission to: <b>RAN # 7</b>	for approval	<input checked="" type="checkbox"/>	strategic	<input type="checkbox"/>
list expected approval meeting # here ↑	for information	<input type="checkbox"/>	non-strategic	<input type="checkbox"/>
				(for SMG use only)

Form: CR cover sheet, version 2 for 3GPP and SMG The latest version of this form is available from: <ftp://ftp.3gpp.org/Information/CR-Form-v2.doc>

**Proposed change affects:** (U)SIM  ME  UTRAN / Radio  Core Network   
(at least one should be marked with an X)

**Source:** TSG RAN WG1 **Date:** 16-Feb-2000

**Subject:** Definition clarification for TS 25.212

**Work item:**

<b>Category:</b>	F Correction <input type="checkbox"/> A Corresponds to a correction in an earlier release <input type="checkbox"/> B Addition of feature <input type="checkbox"/> C Functional modification of feature <input type="checkbox"/> D Editorial modification <input checked="" type="checkbox"/>	<b>Release:</b>	Phase 2 <input type="checkbox"/> Release 96 <input type="checkbox"/> Release 97 <input type="checkbox"/> Release 98 <input type="checkbox"/> Release 99 <input checked="" type="checkbox"/> Release 00 <input type="checkbox"/>
------------------	--	-----------------	--

(only one category shall be marked with an X)

**Reason for change:** The relation between compressed mode parameters in 25.212 and in 25.215 is not mentioned; this is added.

**Clauses affected:** 3.1, 3.3

<b>Other specs affected:</b>	Other 3G core specifications <input type="checkbox"/> Other GSM core specifications <input type="checkbox"/> MS test specifications <input type="checkbox"/> BSS test specifications <input type="checkbox"/> O&M specifications <input type="checkbox"/>	→ List of CRs: → List of CRs: → List of CRs: → List of CRs: → List of CRs:	
------------------------------	---	--	--

**Other comments:**

<----- double-click here for help and instructions on how to create a CR.

---

# 1 Scope

The present document describes the characteristics of the Layer 1 multiplexing and channel coding in the FDD mode of UTRA.

---

# 2 References

The following documents contain provisions which, through reference in this text, constitute provisions of the present document.

- References are either specific (identified by date of publication, edition number, version number, etc.) or non-specific.
- For a specific reference, subsequent revisions do not apply.
- For a non-specific reference, the latest version applies.

- [1] 3G TS 25.201: "Physical layer – General Description"
- [2] 3G TS 25.211: "Physical channels and mapping of transport channels onto physical channels (FDD)"
- [3] 3G TS 25.213: "Spreading and modulation (FDD)"
- [4] 3G TS 25.214: "Physical layer procedures (FDD)"
- [5] 3G TS 25.215: "Measurements (FDD)"
- [6] 3G TS 25.221: "Physical channels and mapping of transport channels onto physical channels (TDD)"
- [7] 3G TS 25.222: "Multiplexing and channel coding (TDD)"
- [8] 3G TS 25.223: "Spreading and modulation (TDD)"
- [9] 3G TS 25.224: "Physical layer procedures (TDD)"
- [10] 3G TS 25.225: "Measurements (TDD)"
- [11] 3G TS 25.302: "Services Provided by the Physical Layer"
- [12] 3G TS 25.402: "Synchronisation in UTRAN, Stage 2"

---

# 3 Definitions, symbols and abbreviations

## 3.1 Definitions

For the purposes of the present document, the [following] terms and definitions [given in ... and the following] apply.

**TG:** Transmission Gap is consecutive empty slots that have been obtained with a transmission time reduction method. The transmission gap can be contained in one or two consecutive radio frames.

**TGL:** Transmission Gap Length is the number of consecutive empty slots that have been obtained with a transmission time reduction method.  $0 \leq TGL \leq 14$ . The CFNs of the radio frames containing the first empty slot of the transmission gaps, the CFNs of the radio frames containing the last empty slot, the respective positions  $N_{\text{first}}$  and  $N_{\text{last}}$  within these frames of the first and last empty slots of the transmission gaps, and the transmission gap lengths can be calculated with the compressed mode parameters described in [5].

**TrCH number:** Transport channel number represents a TrCH ID assigned to L1 by L2. Transport channels are multiplexed to the CCTrCH in the ascending order of these IDs.

## 3.2 Symbols

For the purposes of the present document, the following symbols apply:

$\lceil x \rceil$	round towards $\infty$ , i.e. integer such that $x \leq \lceil x \rceil < x+1$
$\lfloor x \rfloor$	round towards $-\infty$ , i.e. integer such that $x-1 < \lfloor x \rfloor \leq x$
$ x $	absolute value of $x$
$N_{first}$	The first slot in the $TG$ .
$N_{last}$	The last slot in the $TG$ . $N_{last}$ is either a slot in the same radio frame as $N_{first}$ or a slot in the radio frame immediately following the slot that contains $N_{first}$ .

Unless otherwise is explicitly stated when the symbol is used, the meaning of the following symbols is:

$i$	TrCH number
$j$	TFC number
$k$	Bit number
$l$	TF number
$m$	Transport block number
$n_i$	Radio frame number of TrCH $i$ .
$p$	PhCH number
$r$	Code block number
$I$	Number of TrCHs in a CCTrCH.
$C_i$	Number of code blocks in one TTI of TrCH $i$ .
$F_i$	Number of radio frames in one TTI of TrCH $i$ .
$M_i$	Number of transport blocks in one TTI of TrCH $i$ .
$P$	Number of PhCHs used for one CCTrCH.
$PL$	Puncturing Limit for the uplink. Signalled from higher layers
$RM_i$	Rate Matching attribute for TrCH $i$ . Signalled from higher layers.

Temporary variables, i.e. variables used in several (sub)sections with different meaning.

$x, X$
$y, Y$
$z, Z$

## 3.3 Abbreviations

For the purposes of the present document, the following abbreviations apply:

ARQ	Automatic Repeat Request
BCH	Broadcast Channel
BER	Bit Error Rate
BLER	Block Error Rate
BS	Base Station
CCPCH	Common Control Physical Channel
CCTrCH	Coded Composite Transport Channel
<del>CFN</del>	<del>Connection Frame Number</del>
CRC	Cyclic Redundancy Code
DCH	Dedicated Channel
DL	Downlink (Forward link)
DPCH	Dedicated Physical Channel
DPCCH	Dedicated Physical Control Channel
DPDCH	Dedicated Physical Data Channel
DS-CDMA	Direct-Sequence Code Division Multiple Access
DSCH	Downlink Shared Channel
DTX	Discontinuous Transmission
FACH	Forward Access Channel

FDD            Frequency Division Duplex

# CHANGE REQUEST

Please see embedded help file at the bottom of this page for instructions on how to fill in this form correctly.

**21.212**

**CR 039r1**

Current Version: **3.1.0**

GSM (AA.BB) or 3G (AA.BBB) specification number ↑

↑ CR number as allocated by MCC support team

For submission to: **TSG RAN #7** for approval  
 list expected approval meeting # here for information  
 ↑

<input checked="" type="checkbox"/>
<input type="checkbox"/>

strategic  
 non-strategic

<input type="checkbox"/>
<input type="checkbox"/>

(for SMG Use only)

Form: CR cover sheet, version 2 for 3GPP and SMG The latest version of this form is available from: ftp://ftp.3gpp.org/Information/CR-Form-v2.doc

**Proposed change affects:** (U)SIM  ME  UTRAN / Radio  Core Network   
 (at least one should be marked with an X)

**Source:** TSG RAN WG1 **Date:** 2000-01-18

**Subject:** Clarification on TFCI coding input

**Work item:**

<b>Category:</b>  (only one category shall be marked with an X)	F Correction	<input checked="" type="checkbox"/>	<b>Release:</b>	Phase 2	<input type="checkbox"/>
	A Corresponds to a correction in an earlier release	<input type="checkbox"/>		Release 96	<input type="checkbox"/>
	B Addition of feature	<input type="checkbox"/>		Release 97	<input type="checkbox"/>
	C Functional modification of feature	<input type="checkbox"/>		Release 98	<input type="checkbox"/>
	D Editorial modification	<input type="checkbox"/>		Release 99	<input checked="" type="checkbox"/>
			Release 00	<input type="checkbox"/>	

**Reason for change:** The Mapping between RRC TFC index and physical layer TFCI bits is currently not explicit. This CR specifies the relation between the TFCI information bits and TFC indexes defined by the RRC layer.

**Clauses affected:** 4.3.3 & 4.3.4

<b>Other specs affected:</b>	Other 3G core specifications	<input type="checkbox"/>	→ List of CRs:	
	Other GSM core specifications	<input type="checkbox"/>	→ List of CRs:	
	MS test specifications	<input type="checkbox"/>	→ List of CRs:	
	BSS test specifications	<input type="checkbox"/>	→ List of CRs:	
	O&M specifications	<input type="checkbox"/>	→ List of CRs:	

**Other comments:**



<----- double-click here for help and instructions on how to create a CR.



### 4.3.3 Coding of Transport-Format-Combination Indicator (TFCI)

The TFCI bits are encoded using a (32, 10) sub-code of the second order Reed-Muller code. The coding procedure is as shown in figure 10.

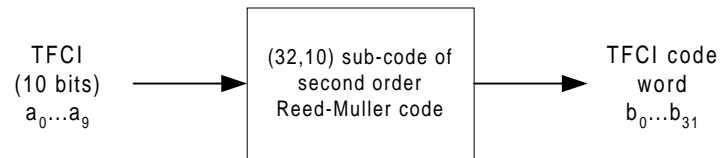

**Figure 10: Channel coding of TFCI bits**

If the TFCI consist of less than 10 bits, it is padded with zeros to 10 bits, by setting the most significant bits to zero. The length of the TFCI code word is 32 bits.

The code words of the (32,10) sub-code of second order Reed-Muller code are linear combination of 10 basis sequences. The basis sequences are as in the following table 7.

Table 7: Basis sequences for (32,10) TFCI code

i	M <sub>i,0</sub>	M <sub>i,1</sub>	M <sub>i,2</sub>	M <sub>i,3</sub>	M <sub>i,4</sub>	M <sub>i,5</sub>	M <sub>i,6</sub>	M <sub>i,7</sub>	M <sub>i,8</sub>	M <sub>i,9</sub>
0	1	1	0	0	0	0	0	0	0	0
1	1	0	1	0	0	0	1	0	0	0
2	1	1	1	0	0	0	0	0	0	1
3	1	0	0	1	0	0	1	0	1	1
4	1	1	0	1	0	0	0	0	0	1
5	1	0	1	1	0	0	0	0	1	0
6	1	1	1	1	0	0	0	1	0	0
7	1	0	0	0	1	0	0	1	1	0
8	1	1	0	0	1	0	1	1	1	0
9	1	0	1	0	1	0	1	0	1	1
10	1	1	1	0	1	0	0	0	1	1
11	1	0	0	1	1	0	0	1	1	0
12	1	1	0	1	1	0	0	1	0	1
13	1	0	1	1	1	0	1	0	0	1
14	1	1	1	1	1	0	1	1	1	1
15	1	1	0	0	0	1	1	1	0	0
16	1	0	1	0	0	1	1	1	0	1
17	1	1	1	0	0	1	1	0	1	0
18	1	0	0	1	0	1	0	1	1	1
19	1	1	0	1	0	1	0	1	0	1
20	1	0	1	1	0	1	0	0	1	1
21	1	1	1	1	0	1	0	1	1	1
22	1	0	0	0	1	1	0	1	0	0
23	1	1	0	0	1	1	1	1	0	1
24	1	0	1	0	1	1	1	0	1	0
25	1	1	1	0	1	1	1	0	0	1
26	1	0	0	1	1	1	0	0	1	0
27	1	1	0	1	1	1	1	1	0	0
28	1	0	1	1	1	1	1	1	1	0
29	1	1	1	1	1	1	1	1	1	1
30	1	0	0	0	0	0	0	0	0	0
31	1	0	0	0	0	1	1	0	0	0

Let's define the TFCI information bits as  $a_0, a_1, a_2, a_3, a_4, a_5, a_6, a_7, a_8, a_9$  ( $a_0$  is LSB and  $a_9$  is MSB). The TFCI information bits shall correspond to the TFC index (expressed in unsigned binary form) defined by the RRC layer to reference the TFC of the CCTrCH in the associated DPCH radio frame. For TFCI information bits  $a_0, a_1, a_2, a_3, a_4, a_5, a_6, a_7, a_8, a_9$  ( $a_0$  is LSB and  $a_9$  is MSB),

The output code word bits  $b_i$  are given by:

$$b_i = \sum_{n=0}^9 (a_n \times M_{i,n}) \bmod 2$$

where  $i=0\dots31$ .

The output bits are denoted by  $b_k$ ,  $k = 0, 1, 2, \dots, 31$ .

In downlink, when the SF < 128 the encoded TFCI code words are repeated yielding 8 encoded TFCI bits per slot in normal mode and 16 encoded TFCI bits per slot in compressed mode. Mapping of repeated bits to slots is explained in section 4.3.5.

#### 4.3.4 Operation of Transport-Format-Combination Indicator (TFCI) in Split Mode

In the case of DCH in Split Mode, the UTRAN shall operate with as follows:

- If one of the ~~links-DCH~~ is associated with a DSCH, the TFCI code word may be split in such a way that the code word relevant for TFCI activity indication is not transmitted from every cell. The use of such a functionality shall be indicated by higher layer signalling.

The TFCI bits are encoded using a (16, 5) bi-orthogonal (or first order Reed-Muller) code. The coding procedure is as shown in figure 11.

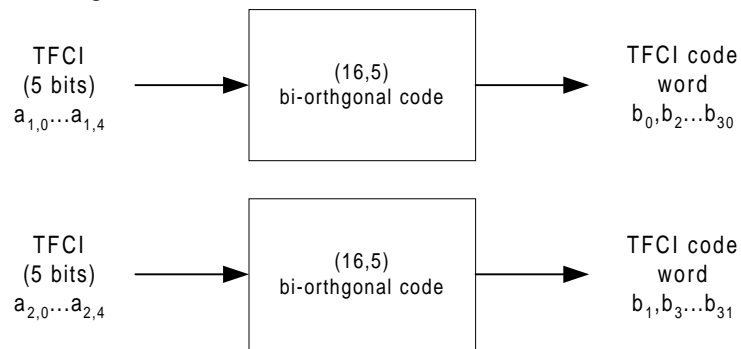

**Figure 11: Channel coding of split mode TFCI bits**

The code words of the (16,5) bi-orthogonal code are linear combinations of 5 basis sequences as defined in table 8 below.

**Table 8: Basis sequences for (16,5) TFCI code**

i	M <sub>i,0</sub>	M <sub>i,1</sub>	M <sub>i,2</sub>	M <sub>i,3</sub>	M <sub>i,4</sub>
0	1	1	0	0	0
1	1	0	1	0	0
2	1	1	1	0	0
3	1	0	0	1	0
4	1	1	0	1	0
5	1	0	1	1	0
6	1	1	1	1	0
7	1	0	0	0	1
8	1	1	0	0	1
9	1	0	1	0	1
10	1	1	1	0	1
11	1	0	0	1	1
12	1	1	0	1	1
13	1	0	1	1	1
14	1	1	1	1	1
15	1	0	0	0	0

For TFCI information bits for DCH  $a_{1,0}, a_{1,1}, a_{1,2}, a_{1,3}, a_{1,4}$  ( $a_{1,0}$  is LSB and  $a_{1,4}$  is MSB) and for DSCH  $a_{2,0}, a_{2,1}, a_{2,2}, a_{2,3}, a_{2,4}$  ( $a_{2,0}$  is LSB and  $a_{2,4}$  is MSB), the output code word bits  $b_0, b_1, \dots, b_{31}$  are given by:

Let's define a first set of TFCI information bits as  $a_{1,0}, a_{1,1}, a_{1,2}, a_{1,3}, a_{1,4}$  ( $a_{1,0}$  is LSB and  $a_{1,4}$  is MSB). This set of TFCI information bits shall correspond to the TFC index (expressed in unsigned binary form) defined by the RRC layer to reference the TFC of the DCH CTrCH in the associated DPCH radio frame.

Let's define a second set of TFCI information bits as  $a_{2,0}, a_{2,1}, a_{2,2}, a_{2,3}, a_{2,4}$  ( $a_{2,0}$  is LSB and  $a_{2,4}$  is MSB). This set of TFCI information bits shall correspond to the TFC index (expressed in unsigned binary form) defined by the RRC layer to reference the TFC of the associated DSCH CTrCH in the corresponding PDSCH radio frame.

The output code word bits  $b_k$  are given by:

$$b_{2i} = \sum_{n=0}^4 (a_{1,n} \times M_{i,n}) \bmod 2;$$

$$b_{2i+1} = \sum_{n=0}^4 (a_{2,n} \times M_{i,n}) \bmod 2$$

where  $i=0 \dots 15, j=0,1$ .

The output bits are denoted by  $b_k, k = 0, 1, 2, \dots, 31$ .



## 3.2 Symbols

For the purposes of the present document, the following symbols apply:

$\lceil x \rceil$	round towards $\infty$ , i.e. integer such that $x \leq \lceil x \rceil < x+1$
$\lfloor x \rfloor$	round towards $-\infty$ , i.e. integer such that $x-1 < \lfloor x \rfloor \leq x$
$ x $	absolute value of $x$

$N_{first}$	The first slot in the <i>TG</i> .
$N_{last}$	The last slot in the <i>TG</i> . $N_{last}$ is either a slot in the same radio frame as $N_{first}$ or a slot in the radio frame immediately following the slot that contains $N_{first}$ .

$N_{tr}$  Number of transmitted slots in a radio frame.

Unless otherwise is explicitly stated when the symbol is used, the meaning of the following symbols is:

$i$	TrCH number
$j$	TFC number
$k$	Bit number
$l$	TF number
$m$	Transport block number
$n_i$	Radio frame number of TrCH $i$ .
$p$	PhCH number
$r$	Code block number
$I$	Number of TrCHs in a CCTrCH.
$C_i$	Number of code blocks in one TTI of TrCH $i$ .
$F_i$	Number of radio frames in one TTI of TrCH $i$ .
$M_i$	Number of transport blocks in one TTI of TrCH $i$ .
$P$	Number of PhCHs used for one CCTrCH.
$PL$	Puncturing Limit for the uplink. Signalled from higher layers
$RM_i$	Rate Matching attribute for TrCH $i$ . Signalled from higher layers.

Temporary variables, i.e. variables used in several (sub)sections with different meaning.

$x, X$   
 $y, Y$   
 $z, Z$

#### 4.2.7.1.1 Determination of SF and number of PhCHs needed

In uplink, puncturing can be applied to match the CCTrCH bit rate to the PhCH bit rate. The bit rate of the PhCH(s) is limited by the UE capability and restrictions imposed by UTRAN, through limitations on the PhCH spreading factor. The maximum amount of puncturing that can be applied is signalled from higher layers and denoted by  $PL$ . The number of available bits in the radio frames of one PhCH for all possible spreading factors is given in [2]. Denote these values by  $N_{256}$ ,  $N_{128}$ ,  $N_{64}$ ,  $N_{32}$ ,  $N_{16}$ ,  $N_8$ , and  $N_4$ , where the index refers to the spreading factor. The possible number of bits available to the CCTrCH on all PhCHs, values of  $N_{data}$ , then are  $\{N_{256}, N_{128}, N_{64}, N_{32}, N_{16}, N_8, N_4, 2N_4, 3N_4, 4N_4, 5N_4, 6N_4\}$ . Depending on the UE capability and the restrictions from UTRAN, the allowed set of  $N_{data}$ , denoted SET0, can be a subset of  $\{N_{256}, N_{128}, N_{64}, N_{32}, N_{16}, N_8, N_4, 2N_4, 3N_4, 4N_4, 5N_4, 6N_4\}$ .  $N_{data,j}$  for the transport format combination  $j$  is determined by executing the following algorithm:

SET1 = {  $N_{data}$  in SET0 such that is non negative }

If SET1 is not empty and the smallest element of SET1 requires just one PhCH then

$$N_{data,j} = \min \text{SET1}$$

else

$$\text{SET2} = \{ N_{data} \text{ in SET0 such that } N_{data} - PL \cdot \sum_{x=1}^I \frac{RM_x}{\min_{1 \leq y \leq I} \{RM_y\}} \cdot N_{x,j} \text{ is non negative} \}$$

Sort SET2 in ascending order

$$N_{data} = \min \text{SET2}$$

While  $N_{data}$  is not the max of SET2 and the follower of  $N_{data}$  requires no additional PhCH do

$$N_{data} = \text{follower of } N_{data} \text{ in SET2}$$

End while

$$N_{data,j} = N_{data}$$

End if

#### 4.2.7.1.2 Determination of parameters needed for calculating the rate matching pattern

The number of bits to be repeated or punctured,  $\Delta N_{ij}$ , within one radio frame for each TrCH  $i$  is calculated with equation 1 for all possible transport format combinations  $j$  and selected every radio frame.  $N_{data,j}$  is given from section 4.2.7.1.1.

In compressed mode  $N_{data,j}$  is replaced by  $N_{data,j}^{cm}$  in Equation 1.  $N_{data,j}^{cm}$  is given as follows: from the following relation:

In compressed mode by higher layer scheduling,  $N_{data,j}^{cm}$  is obtained by executing the algorithm in section 4.2.7.1.1 but

with the number of bits in one radio frame of one PhCH reduced to  $\frac{N_{tr}}{15}$  of the value in normal mode.

$N_{tr}$  is the number of transmitted slots in a compressed radio frame and is defined by the following relation:

$$N_{tr} = \begin{cases} 15 - TGL, & \text{if } N_{first} + TGL \leq 15 \\ N_{first}, & \text{in first frame if } N_{first} + TGL > 15 \\ 30 - TGL - N_{first}, & \text{in second frame if } N_{first} + TGL > 15 \end{cases}$$

$N_{first}$  and  $TGL$  are defined in section 4.4.

~~In compressed mode by spreading factor reduction,  $N_{data,j}^{cm} = 2N_{data,j} - 2N_{TGL}$ , where for compressed mode by~~

~~$$N_{TGL} = \frac{15 - N_{tr}}{15} N_{data,j}$$~~

~~$N_{data,j}^{cm} = N_{data,j} - N_{TGL}$ , for compressed mode by higher layer scheduling~~

~~$$N_{TGL} = \begin{cases} \frac{TGL}{15} N_{data,j}, & \text{if } N_{first} + TGL \leq 15 \\ \frac{15 - N_{first}}{15} N_{data,j}, & \text{in first frame if } N_{first} + TGL > 15 \\ \frac{TGL - (15 - N_{first})}{15} N_{data,j}, & \text{in second frame if } N_{first} + TGL > 15 \end{cases}$$~~

~~$N_{first}$  and  $TGL$  are defined in section 4.4.~~

If  $\Delta N_{ij} = 0$  then the output data of the rate matching is the same as the input data and the rate matching algorithm of section 4.2.7.5 does not need to be executed.

If  $\Delta N_{ij} \neq 0$  the parameters listed in sections 4.2.7.1.2.1 and 4.2.7.1.2.2 shall be used for determining  $e_{ini}$ ,  $e_{plus}$ , and  $e_{minus}$  (regardless if the radio frame is compressed or not).



**3GPP TSG RAN Meeting #7**  
**Madrid, Spain, 13-15 March 2000**

**Document R1-00-0418**

e.g. for 3GPP use the format TP-99xxx  
 or for SMG, use the format P-99-xxx

<b>CHANGE REQUEST</b>			Please see embedded help file at the bottom of this page for instructions on how to fill in this form correctly.
<b>25.212</b>	<b>CR</b>	<b>042r5</b>	Current Version: <b>3.1.0</b>
GSM (AA.BB) or 3G (AA.BBB) specification number ↑		↑ CR number as allocated by MCC support team	
For submission to: <b>WG1 # 11</b> <small>list expected approval meeting # here</small>	for approval for information	<input checked="" type="checkbox"/> <input type="checkbox"/>	strategic non-strategic <input type="checkbox"/> <input type="checkbox"/> <small>(for SMG use only)</small>

Form: CR cover sheet, version 2 for 3GPP and SMG The latest version of this form is available from: <ftp://ftp.3gpp.org/Information/CR-Form-v2.doc>

**Proposed change affects:** (U)SIM  ME  UTRAN / Radio  Core Network   
(at least one should be marked with an X)

**Source:** TSG RAN WG1 **Date:** \_\_\_\_\_

**Subject:** Downlink Compressed Mode by puncturing

**Work item:** TS 25.212

<b>Category:</b>	F Correction <input type="checkbox"/> A Corresponds to a correction in an earlier release <input type="checkbox"/> B Addition of feature <input type="checkbox"/> C Functional modification of feature <input checked="" type="checkbox"/> D Editorial modification <input type="checkbox"/>	<b>Release:</b>	Phase 2 <input type="checkbox"/> Release 96 <input type="checkbox"/> Release 97 <input type="checkbox"/> Release 98 <input type="checkbox"/> Release 99 <input checked="" type="checkbox"/> Release 00 <input type="checkbox"/>
------------------	--	-----------------	--

(only one category shall be marked with an X)

**Reason for change:** Introduction of a method for compressed mode by puncturing, which requires minimal changes to the multiplexing chain.

**Clauses affected:** 4.2.5, 4.2.7, 4.2.9, 4.2.10

**Other specs affected:**

Other 3G core specifications	<input type="checkbox"/>	→ List of CRs:	
Other GSM core specifications	<input type="checkbox"/>	→ List of CRs:	
MS test specifications	<input type="checkbox"/>	→ List of CRs:	
BSS test specifications	<input type="checkbox"/>	→ List of CRs:	
O&M specifications	<input type="checkbox"/>	→ List of CRs:	

**Other comments:** \_\_\_\_\_



<----- double-click here for help and instructions on how to create a CR.

## 4.2 Transport-channel coding/multiplexing

Data arrives to the coding/multiplexing unit in form of transport block sets once every transmission time interval. The transmission time interval is transport-channel specific from the set {10 ms, 20 ms, 40 ms, 80 ms}.

The following coding/multiplexing steps can be identified:

- Add CRC to each transport block (see section 4.2.1)
- Transport block concatenation and code block segmentation (see section 4.2.2)
- Channel coding (see section 4.2.3)
- Rate matching (see section 4.2.7)
- Insertion of discontinuous transmission (DTX) indication bits (see section 4.2.9)
- Interleaving (two steps, see sections 4.2.4 and 4.2.11)
- Radio frame segmentation (see section 4.2.6)
- Multiplexing of transport channels (see section 4.2.8)
- Physical channel segmentation (see section 4.2.10)
- Mapping to physical channels (see section 4.2.12)

The coding/multiplexing steps for uplink and downlink are shown in figure 1 and figure 2 respectively.

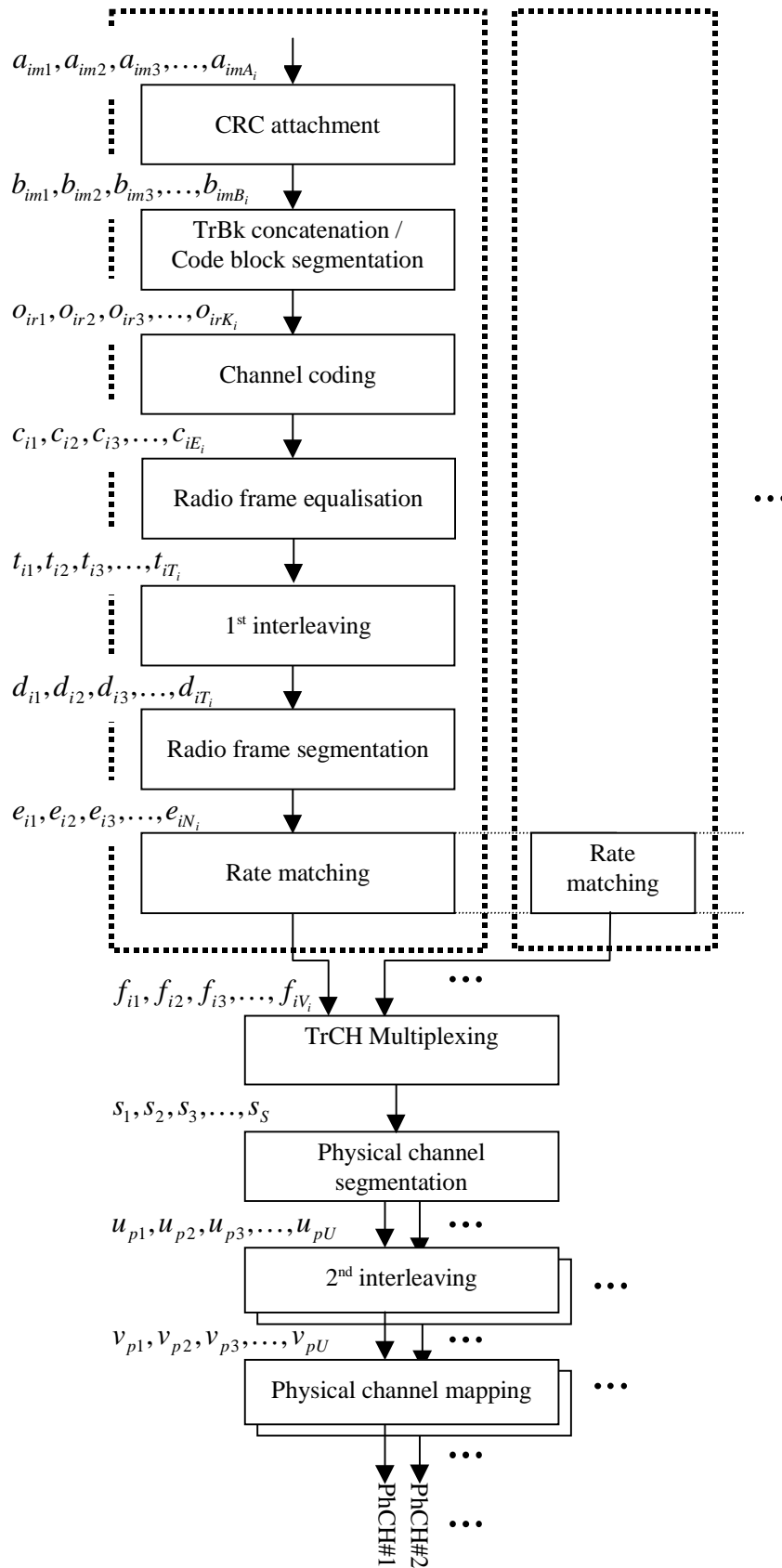
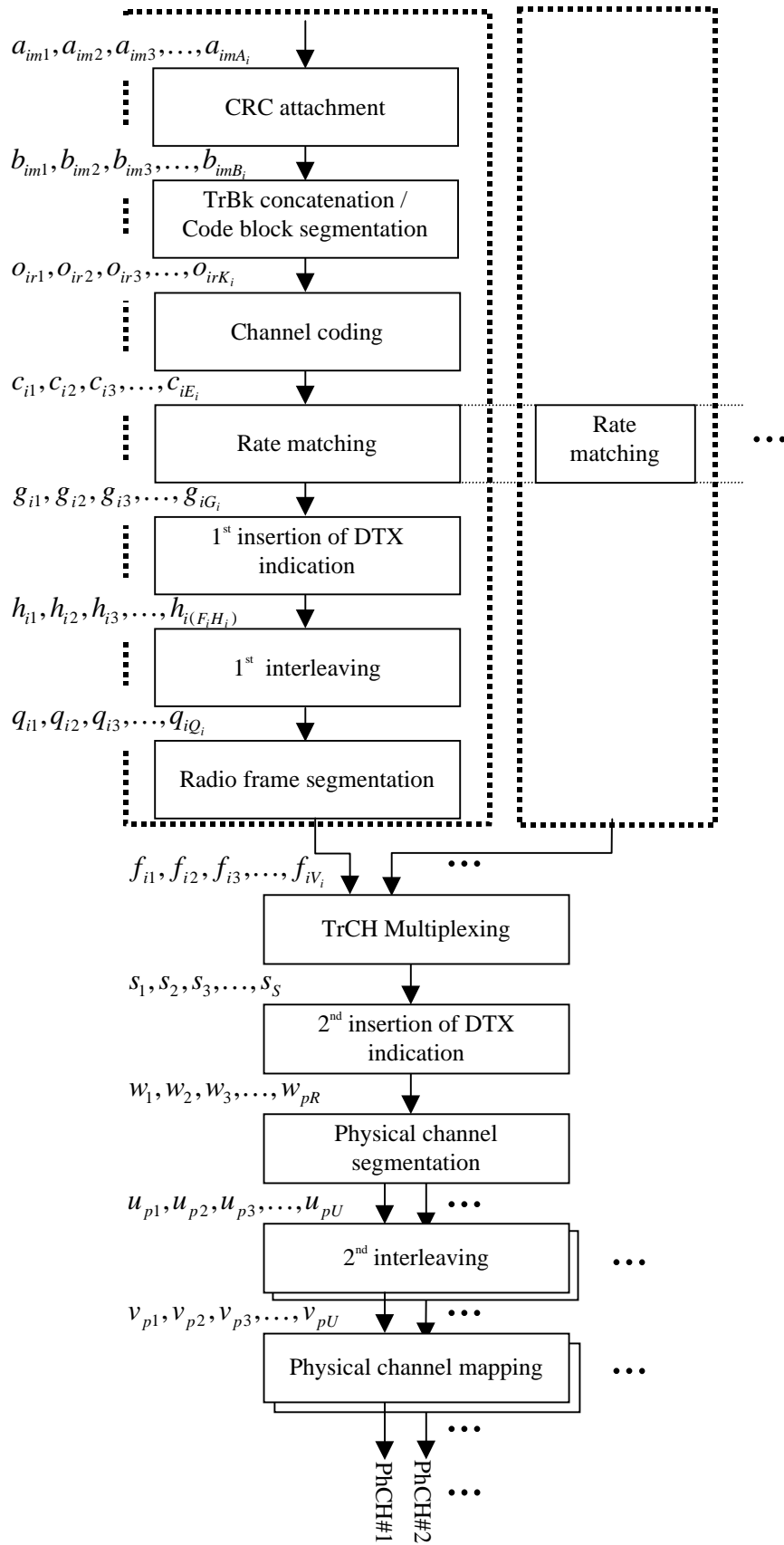
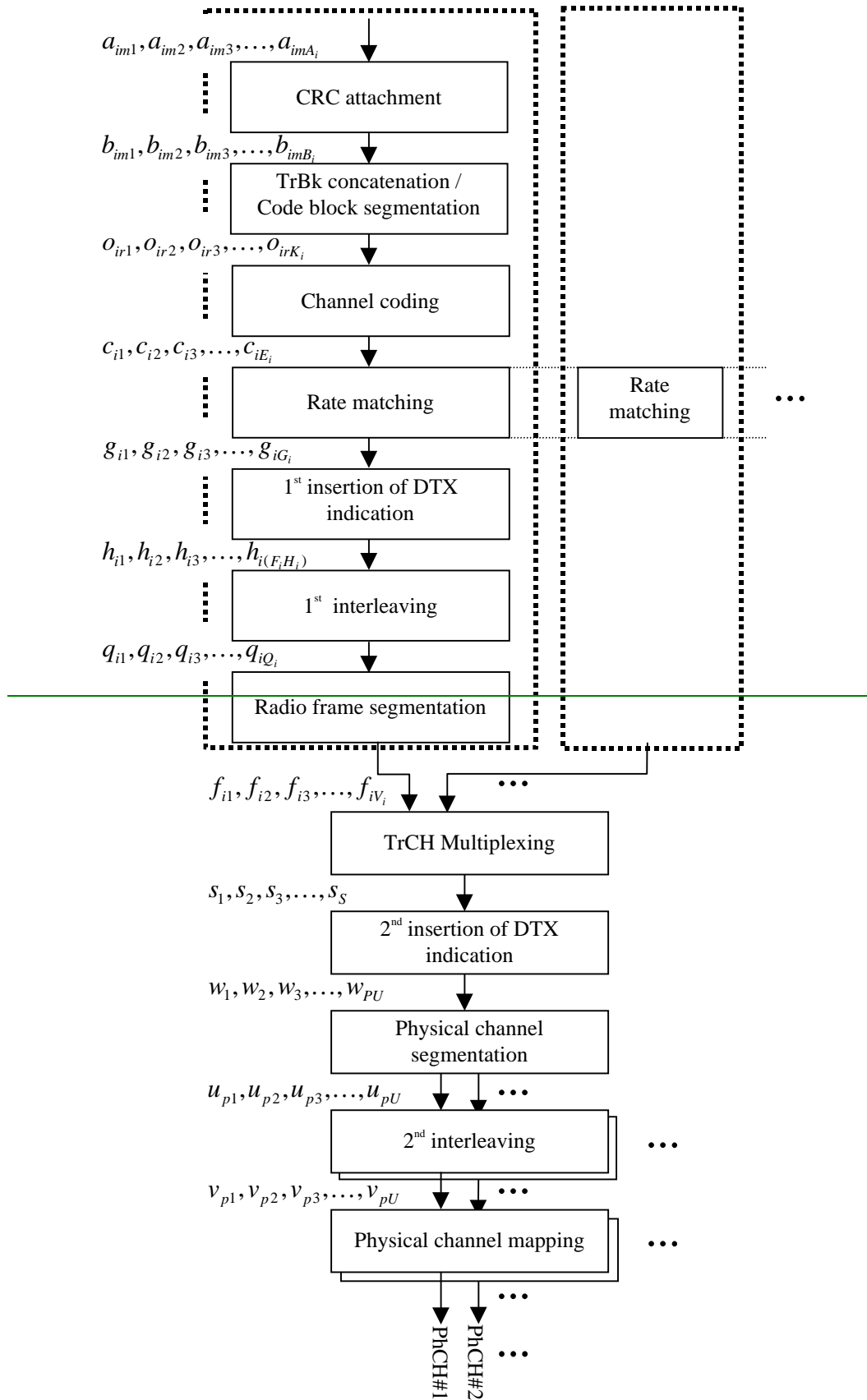

Figure 1: Transport channel multiplexing structure for uplink





**Figure 2: Transport channel multiplexing structure for downlink**

The single output data stream from the TrCH multiplexing is denoted *Coded Composite Transport Channel (CCTrCH)*. A CCTrCH can be mapped to one or several physical channels.

## 4.2.5 1<sup>st</sup> interleaving

In Compressed Mode by puncturing, bits marked with a fourth value on top of {0, 1,  $\delta$ } and noted p, are introduced in the radio frames to be compressed, in positions corresponding to the first bits of the radio frames. They will be removed in a later stage of the multiplexing chain to create the actual gap. Additional puncturing has been performed in the rate matching step, over the TTI containing the compressed radio frame, to create room for these p-bits. The following section describes this feature.

### 4.2.5.1 Insertion of marked bits in the sequence to be input in first interleaver

In normal mode, compressed mode by higher layer scheduling, and compressed mode by spreading factor reduction,

$$x_{jk} = z_{jk} \text{ and } X_j = Z_j$$

In case of compressed mode by puncturing and fixed positions, sequence  $x_{i,k}$  which will be input to first interleaver for TrCh  $i$  and TTI  $m$  within largest TTI, is built from bits  $z_{i,k}, k=1, \dots, Z_{i,m}$  plus  $Np^{TTI,m}_{i,max}$  bits marked p and  $X_j = Z_j + Np^{TTI,m}_{i,max}$ , as is described thereafter.

$Np^{TTI,m}_{i,max}$  is defined in the Rate Matching section 4.2.7

$P_{Fi}[x]$  defines the inter column permutation function for a TTI of length  $F_i * 10\text{ms}$ , as defined in Table 3 above.  $P_{Fi}[x]$  is the Bit Reversal function of  $x$  on  $\log_2(F_i)$  bits.

Note:

- $C[x], x=0$  to  $F_i - 1$ , the number of bits p which have to be inserted in each of the  $F_i$  segments of the TTI, i.e. in each column of the first interleaver.  $C[x]$  is equal to  $Np^{x}_{i,max}$  for  $x$  equal 0 to  $F_i - 1$  for fixed positions. It is noted  $Np^{x}_{i,m}$  in the following initialisation step.
- $cbi[x], x=0$  to  $F_i - 1$ , the counter of the number of bits p inserted in each of the  $F_i$  segments of the TTI, i.e. in each column of the first interleaver.

$col = 0$

**while**  $col < F_i$  **do**

$C[col] = Np^{col}_{i,m}$  -- initialisation of number of bits p to be inserted in each of the  $F_i$  segments of the TTI

$cbi[col] = 0$  -- initialisation of counter of number of bits p inserted in each of the  $F_i$  segments of the TTI

**end do**

$n = 0, m = 0$

**while**  $n < X_j$  **do**

$col = n \bmod F_i$

**if**  $cbi[col] < C[P_{Fi}(col)]$  **do**

$x_{i,n} = p$  -- insert one p bit

$cbi[col] = cbi[col] + 1$  -- update counter of number of bits p inserted

**else** -- no more p bit to insert in this segment

$x_{i,n} = z_{i,m}$

$m = m + 1$

**endif**

$n = n + 1$

**end do**

### 4.2.5.2 1<sup>st</sup> interleaver operation

The 1<sup>st</sup> interleaving is a block interleaver with inter-column permutations. The input bit sequence to the 1<sup>st</sup> interleaver is denoted by  $x_{i1}, x_{i2}, x_{i3}, \dots, x_{iX_i}$ , where  $i$  is TrCH number and  $X_i$  the number of bits (at this stage  $X_i$  is assumed and guaranteed to be an integer multiple of TTI). The output bit sequence is derived as follows:

- (1) Select the number of columns  $C_I$  from table 3.
- (2) Determine the number of rows  $R_I$  defined as

$$R_I = X_i / C_I$$

- (3) Write the input bit sequence into the  $R_I \times C_I$  rectangular matrix row by row starting with bit  $x_{i1}$  in the first column of the first row and ending with bit  $x_{i,(R_I C_I)}$  in column  $C_I$  of row  $R_I$ :

$$\begin{bmatrix} x_{i1} & x_{i2} & x_{i3} & \dots & x_{iC_I} \\ x_{i,(C_I+1)} & x_{i,(C_I+2)} & x_{i,(C_I+3)} & \dots & x_{i,(2C_I)} \\ \vdots & \vdots & \vdots & \dots & \vdots \\ x_{i,((R_I-1)C_I+1)} & x_{i,((R_I-1)C_I+2)} & x_{i,((R_I-1)C_I+3)} & \dots & x_{i,(R_I C_I)} \end{bmatrix}$$

- (4) Perform the inter-column permutation based on the pattern  $\{P_1(j)\}$  ( $j=0,1, \dots, C-1$ ) shown in table 3, where  $P_1(j)$  is the original column position of the  $j$ -th permuted column. After permutation of the columns, the bits are denoted by  $y_{ik}$ :

$$\begin{bmatrix} y_{i1} & y_{i,(R_I+1)} & y_{i,(2R_I+1)} & \dots & y_{i,((C_I-1)R_I+1)} \\ y_{i2} & y_{i,(R_I+2)} & y_{i,(2R_I+2)} & \dots & y_{i,((C_I-1)R_I+2)} \\ \vdots & \vdots & \vdots & \dots & \vdots \\ y_{iR_I} & y_{i,(2R_I)} & y_{i,(3R_I)} & \dots & y_{i,(C_I R_I)} \end{bmatrix}$$

- (5) Read the output bit sequence  $y_{i1}, y_{i2}, y_{i3}, \dots, y_{i,(C_I R_I)}$  of the 1<sup>st</sup> interleaving column by column from the inter-column permuted  $R_I \times C_I$  matrix. Bit  $y_{i1}$  corresponds to the first row of the first column and bit  $y_{i,(R_I C_I)}$  corresponds to row  $R_I$  of column  $C_I$ .

**Table 3**

TTI	Number of columns $C_I$	Inter-column permutation patterns
10 ms	1	{0}
20 ms	2	{0,1}
40 ms	4	{0,2,1,3}
80 ms	8	{0,4,2,6,1,5,3,7}

### 4.2.5.34 Relation between input and output of 1<sup>st</sup> interleaving in uplink

The bits input to the 1<sup>st</sup> interleaving are denoted by  $t_{i1}, t_{i2}, t_{i3}, \dots, t_{iT_i}$ , where  $i$  is the TrCH number and  $T_i$  the number of bits. Hence,  $t_{ik} = t_{ik}$  and  $X_i = T_i$ .

The bits output from the 1<sup>st</sup> interleaving are denoted by  $d_{i1}, d_{i2}, d_{i3}, \dots, d_{iT_i}$ , and  $d_{ik} = y_{ik}$ .

#### 4.2.5.42 Relation between input and output of 1<sup>st</sup> interleaving in downlink

If fixed positions of the TrCHs in a radio frame is used then the bits input to the 1<sup>st</sup> interleaving are denoted by  $h_{i1}, h_{i2}, h_{i3}, \dots, h_{i(F_i H_i)}$ , where  $i$  is the TrCH number. Hence,  $x_{Z_{ik}} = h_{ik}$  and  $Z_i = F_i * H_i - Np_{i,max}^{TTI, m}$  in compressed mode by puncturing, and  $x_{Z_i} = F_i H_i$  otherwise.

If flexible positions of the TrCHs in a radio frame is used then the bits input to the 1<sup>st</sup> interleaving are denoted by  $g_{i1}, g_{i2}, g_{i3}, \dots, g_{iG_i}$ , where  $i$  is the TrCH number. Hence,  $x_{Z_{ik}} = g_{ik}$  and  $x_{Z_i} = G_i$ .

The bits output from the 1<sup>st</sup> interleaving are denoted by  $q_{i1}, q_{i2}, q_{i3}, \dots, q_{iQ_i}$ , where  $i$  is the TrCH number and  $Q_i$  is the number of bits. Hence,  $q_{ik} = y_{ik}$ ,  $Q_i = F_i H_i$  if fixed positions are used, and  $Q_i = G_i$  if flexible positions are used.



## 4.2.7 Rate matching

Rate matching means that bits on a transport channel are repeated or punctured. Higher layers assign a rate-matching attribute for each transport channel. This attribute is semi-static and can only be changed through higher layer signalling. The rate-matching attribute is used when the number of bits to be repeated or punctured is calculated.

The number of bits on a transport channel can vary between different transmission time intervals. In the downlink the transmission is interrupted if the number of bits is lower than maximum. When the number of bits between different transmission time intervals in uplink is changed, bits are repeated or punctured to ensure that the total bit rate after TrCH multiplexing is identical to the total channel bit rate of the allocated dedicated physical channels.

If no bits are input to the rate matching for all TrCHs within a CCTrCH, the rate matching shall output no bits for all TrCHs within the CCTrCH and no uplink DPDCH will be selected in the case of uplink rate matching.

### Notation used in section 4.2.7 and subsections:

$N_{ij}$ : For uplink: Number of bits in a radio frame before rate matching on TrCH  $i$  with transport format combination  $j$ .

For downlink : An intermediate calculation variable (not an integer but a multiple of 1/8).

$N_{il}^{TTI}$  : Number of bits in a transmission time interval before rate matching on TrCH  $i$  with transport format  $l$ .  
Used in downlink only.

$\Delta N_{ij}$  : For uplink: If positive - number of bits that should be repeated in each radio frame on TrCH  $i$  with transport format combination  $j$ .

If negative - number of bits that should be punctured in each radio frame on TrCH  $i$  with transport format combination  $j$ .

For downlink : An intermediate calculation variable (not an integer but a multiple of 1/8).

$\Delta N_{il}^{TTI}$  : If positive - number of bits to be repeated in each transmission time interval on TrCH  $i$  with transport format  $j$ .

If negative - number of bits to be punctured in each transmission time interval on TrCH  $i$  with transport format  $j$ .

Used in downlink only.

$Np_{i,l}^{TTI,m}$ ,  $m=0$  to  $F_{max}/F_i - 1$  : Positive or null: number of bits to be removed in TTI number  $m$  within the largest TTI, to create the required gaps in the compressed radio frames of this TTI, in case of compressed mode by puncturing, for TrCh  $i$  with transport format  $l$ . In case of fixed positions and compressed mode by puncturing, this value is noted  $Np_{i,max}^{TTI,m}$  since it is calculated for all TrCh with their maximum number of bits; thus it is the same for all TFCs

Used in downlink only.

$Np_{i,l}^n$ ,  $n=0$  to  $F_{max}-1$  : Positive or null: number of bits, in radio frame number  $n$  within the largest TTI, corresponding to the gap for compressed mode in this radio frame, for TrCH  $i$  with transport format  $l$ . The value will be null for the un-compressed radio frames. In case of fixed positions and compressed mode by puncturing, this value is noted  $Np_{i,max}^n$  since it is calculated for all TrChs with their maximum number of bits; thus it is the same for all TFCs

Used in downlink only.

$N_{TGL}[k]$ ,  $k=0$  to  $F_i - 1$  : Positive or null: number of bits in each radio frame corresponding to the gap for compressed mode for the CCTrCh.

$RM_i$ : Semi-static rate matching attribute for transport channel  $i$ . Signalled from higher layers.

$PL$ : Puncturing limit for uplink. This value limits the amount of puncturing that can be applied in order to avoid multicode or to enable the use of a higher spreading factor. Signalled from higher layers.

$N_{data,j}$ : Total number of bits that are available for the CCTrCH in a radio frame with transport format combination  $j$ .

$I$ : Number of TrCHs in the CCTrCH.

$Z_{ij}$ : Intermediate calculation variable.

$F_i$ : Number of radio frames in the transmission time interval of TrCH  $i$ .

$F_{\max}$  Maximum number of radio frames in a transmission time interval used in the CCTrCH :

$$\underline{F_{\max}} = \max_{1 \leq i \leq I} F_i$$

$n_i$ : Radio frame number in the transmission time interval of TrCH  $i$  ( $0 \leq n_i < F_i$ ).

$q$ : Average puncturing or repetition distance (normalised to only show the remaining rate matching on top of an integer number of repetitions). Used in uplink only.

$I_F(n_i)$ : The inverse interleaving function of the 1<sup>st</sup> interleaver (note that the inverse interleaving function is identical to the interleaving function itself for the 1<sup>st</sup> interleaver). Used in uplink only.

$S(n_i)$ : The shift of the puncturing or repetition pattern for radio frame  $n_i$ . Used in uplink only.

$TF_i(j)$ : Transport format of TrCH  $i$  for the transport format combination  $j$ .

$TFS(i)$ : The set of transport format indexes  $l$  for TrCH  $i$ .

$TFCs$ : The set of transport format combination indexes  $j$ .

$e_{ini}$ : Initial value of variable  $e$  in the rate matching pattern determination algorithm of section 4.2.7.5.

$e_{plus}$ : Increment of variable  $e$  in the rate matching pattern determination algorithm of section 4.2.7.5.

$e_{minus}$ : Decrement of variable  $e$  in the rate matching pattern determination algorithm of section 4.2.7.5.

$b$ : Indicates systematic and parity bits

$b=1$ : Systematic bit.  $X(t)$  in section 4.2.3.2.1.

$b=2$ : 1<sup>st</sup> parity bit (from the upper Turbo constituent encoder).  $Y(t)$  in section 4.2.3.2.1.

$b=3$ : 2<sup>nd</sup> parity bit (from the lower Turbo constituent encoder).  $Y'(t)$  in section 4.2.3.2.1.

The \* (star) notation is used to replace an index  $x$  when the indexed variable  $X_x$  does not depend on the index  $x$ . In the left wing of an assignment the meaning is that " $X_* = Y$ " is equivalent to "**for all  $x$  do  $X_x = Y$** ". In the right wing of an assignment, the meaning is that " $Y = X_*$ " is equivalent to "**take any  $x$  and do  $Y = X_x$** ".

The following relations, defined for all TFC  $j$ , are used when calculating the rate matching parameters:

$$Z_{0,j} = 0$$

$$Z_{ij} = \left[ \frac{\sum_{m=1}^i RM_m \cdot N_{mj}}{\sum_{m=1}^I RM_m \cdot N_{mj}} \cdot N_{data,j} \right] \text{ for all } i = 1 \dots I \quad (1)$$

$$\Delta N_{ij} = Z_{ij} - Z_{i-1,j} - N_{ij} \quad \text{for all } i = 1 \dots I$$

#### 4.2.7.1 Determination of rate matching parameters in uplink

##### 4.2.7.1.1 Determination of SF and number of PhCHs needed

In uplink, puncturing can be applied to match the CCTrCH bit rate to the PhCH bit rate. The bit rate of the PhCH(s) is limited by the UE capability and restrictions imposed by UTRAN, through limitations on the PhCH spreading factor. The maximum amount of puncturing that can be applied is signalled from higher layers and denoted by  $PL$ . The number of available bits in the radio frames for all possible spreading factors is given in [2]. Denote these values by  $N_{256}$ ,  $N_{128}$ ,  $N_{64}$ ,  $N_{32}$ ,  $N_{16}$ ,  $N_8$ , and  $N_4$ , where the index refers to the spreading factor. The possible values of  $N_{data}$  then are  $\{N_{256}, N_{128}, N_{64}, N_{32}, N_{16}, N_8, N_4, 2N_4, 3N_4, 4N_4, 5N_4, 6N_4\}$ . Depending on the UE capability and the restrictions from UTRAN, the allowed set of  $N_{data}$ , denoted SET0, can be a subset of  $\{N_{256}, N_{128}, N_{64}, N_{32}, N_{16}, N_8, N_4, 2N_4, 3N_4, 4N_4, 5N_4, 6N_4\}$ .  $N_{data,j}$  for the transport format combination  $j$  is determined by executing the following algorithm:

$$\text{SET1} = \{ N_{data} \text{ in SET0 such that } N_{data} - \sum_{x=1}^l \frac{RM_x}{\min\{RM_y\}_{1 \leq y \leq l}} \cdot N_{x,j} \text{ is non negative} \}$$

If SET1 is not empty and the smallest element of SET1 requires just one PhCH then

$$N_{data,j} = \min \text{SET1}$$

else

$$\text{SET2} = \{ N_{data} \text{ in SET0 such that } N_{data} - PL \cdot \sum_{x=1}^l \frac{RM_x}{\min\{RM_y\}_{1 \leq y \leq l}} \cdot N_{x,j} \text{ is non negative} \}$$

Sort SET2 in ascending order

$$N_{data} = \min \text{SET2}$$

While  $N_{data}$  is not the max of SET2 and the follower of  $N_{data}$  requires no additional PhCH do

$$N_{data} = \text{follower of } N_{data} \text{ in SET2}$$

End while

$$N_{data,j} = N_{data}$$

End if

##### 4.2.7.1.2 Determination of parameters needed for calculating the rate matching pattern

The number of bits to be repeated or punctured,  $\Delta N_{ij}$ , within one radio frame for each TrCH  $i$  is calculated with equation 1 for all possible transport format combinations  $j$  and selected every radio frame.  $N_{data,j}$  is given from section 4.2.7.1.1.

In compressed mode  $N_{data,j}$  is replaced by  $N_{data,j}^{cm}$  in Equation 1.  $N_{data,j}^{cm}$  is given from the following relation:

$$N_{data,j}^{cm} = 2N_{data,j} - 2N_{TGL}, \text{ for compressed mode by spreading factor reduction}$$

$$N_{data,j}^{cm} = N_{data,j} - N_{TGL}, \text{ for compressed mode by higher layer scheduling}$$

$$N_{TGL} = \begin{cases} \frac{TGL}{15} N_{data,j}, & \text{if } N_{first} + TGL \leq 15 \\ \frac{15 - N_{first}}{15} N_{data,j}, & \text{in first frame if } N_{first} + TGL > 15 \\ \frac{TGL - (15 - N_{first})}{15} N_{data,j}, & \text{in second frame if } N_{first} + TGL > 15 \end{cases}$$

$N_{first}$  and  $TGL$  are defined in section 4.4.

If  $\Delta N_{ij} = 0$  then the output data of the rate matching is the same as the input data and the rate matching algorithm of section 4.2.7.5 does not need to be executed.

If  $\Delta N_{ij} \neq 0$  the parameters listed in sections 4.2.7.1.2.1 and 4.2.7.1.2.2 shall be used for determining  $e_{mi}$ ,  $e_{plus}$ , and  $e_{minus}$  (regardless if the radio frame is compressed or not).

#### 4.2.7.1.2.1 Uncoded and convolutionally encoded TrCHs

$R = \Delta N_{ij} \bmod N_{ij}$  -- note: in this context  $\Delta N_{ij} \bmod N_{ij}$  is in the range of 0 to  $N_{ij}-1$  i.e.  $-1 \bmod 10 = 9$ .

if  $R \neq 0$  and  $2R \leq N_{ij}$

then  $q = \lceil N_{ij} / R \rceil$

else

$q = \lceil N_{ij} / (R - N_{ij}) \rceil$

endif

-- note:  $q$  is a signed quantity.

if  $q$  is even

then  $q' = q + \gcd(|q|, F_i)/F_i$  -- where  $\gcd(|q|, F_i)$  means greatest common divisor of  $|q|$  and  $F_i$

-- note that  $q'$  is not an integer, but a multiple of  $1/8$

else

$q' = q$

endif

for  $x = 0$  to  $F_i-1$

$S(I_F(|\lfloor x \cdot q' \rfloor| \bmod F_i)) = (|\lfloor x \cdot q' \rfloor| \text{ div } F_i)$

end for

$\Delta N_i = \Delta N_{ij}$

$a = 2$

For each radio frame, the rate-matching pattern is calculated with the algorithm in section 4.2.7.5, where :

$X_i = N_{ij}$ , and

$e_{mi} = (a \cdot S(n_i) \cdot |\Delta N_i| + 1) \bmod (a \cdot N_{ij})$ .

$e_{plus} = a \cdot N_{ij}$

$e_{minus} = a \cdot |\Delta N_i|$

puncturing for  $\Delta N < 0$ , repetition otherwise.

#### 4.2.7.1.2.2 Turbo encoded TrCHs

If repetition is to be performed on turbo encoded TrCHs, i.e.  $\Delta N_{ij} > 0$ , the parameters in section 4.2.7.1.2.1 are used.

If puncturing is to be performed, the parameters below shall be used. Index  $b$  is used to indicate systematic ( $b=1$ ), 1<sup>st</sup> parity ( $b=2$ ), and 2<sup>nd</sup> parity bit ( $b=3$ ).

$a=2$  when  $b=2$

$a=1$  when  $b=3$

$$\Delta N_i = \begin{cases} \lfloor \Delta N_{i,j} / 2 \rfloor, & b = 2 \\ \lfloor \Delta N_{i,j} / 2 \rfloor, & b = 3 \end{cases}$$

$$X_i = \lfloor N_{i,j} / 3 \rfloor,$$

$$q = \lfloor X_i / |\Delta N_i| \rfloor$$

if( $q \leq 2$ )

for  $x=0$  to  $F_i-1$

$$S[I_F[(3x+b-1) \bmod F_i]] = x \bmod 2;$$

end for

else

if  $q$  is even

then  $q' = q - \gcd(q, F_i) / F_i$  -- where  $\gcd(q, F_i)$  means greatest common divisor of  $q$  and  $F_i$   
 -- note that  $q'$  is not an integer, but a multiple of  $1/8$

else  $q' = q$

endif

for  $x=0$  to  $F_i-1$

$$r = \lceil x * q' \rceil \bmod F_i;$$

$$S[I_F[(3r+b-1) \bmod F_i]] = \lceil x * q' \rceil \text{ div } F_i;$$

endfor

endif

For each radio frame, the rate-matching pattern is calculated with the algorithm in section 4.2.7.5, where:

$X_i$  is as above,

$$e_{\text{ini}} = (a \cdot S(n_i) \cdot |\Delta N_i| + X_i) \bmod (a \cdot X_i), \text{ if } e_{\text{ini}} = 0 \text{ then } e_{\text{ini}} = a \cdot X_i.$$

$$e_{\text{plus}} = a \cdot X_i$$

$$e_{\text{minus}} = a \cdot |\Delta N_i|$$

#### 4.2.7.2 Determination of rate matching parameters in downlink

For downlink  $N_{\text{data},j}$  does not depend on the transport format combination  $j$ .  $N_{\text{data},*}$  is given by the channelization code(s) assigned by higher layers.

In the following, the total amount of puncturing or repetition for the TTI is calculated.

Additional calculations for compressed mode by puncturing in case of fixed positions are performed to determine this total amount of rate matching needed:

For compressed mode by puncturing, in TTIs where some compressed radio frames occur, the puncturing is increased or the repetition is decreased compared to what is calculated according to the rate matching parameters provided by higher layers. This allows to create room for later insertion of marked bits, noted p-bits, which will identify the positions of the gaps in the compressed radio frames.

The amount of additional puncturing corresponds to the number of bits to create the gap in the TTI for TrCh<sub>i</sub>. In case of fixed positions, it is calculated in addition to the amount of rate matching indicated by higher layers. It is noted  $Np_{i,max}^{TTI,m}$ .

In fixed positions case, to obtain the total rate matching  $\Delta N_{i,\max}^{TTI,cm,m}$  to be performed on the TTI  $m$ ,  $Np^{TTI,m}_{i,\max}$  is subtracted from  $\Delta N_{i,\max}^{TTI,m}$  (calculated based on higher layers RM parameters as for normal rate matching). This allows to create room for the  $Np^{TTI,m}_{i,\max}$  bits  $p$  to be inserted later. If the result is null, i.e. the amount of repetition matches exactly the amount of additional puncturing needed, then no rate matching is necessary.

In case of compressed mode by puncturing and fixed positions, for some calculations,  $N'_{data,*}$  is used for radio frames with gap instead of  $N_{data,*}$ , where  $N'_{data,*} = P(15N'_{data1} + 15N'_{data2}) - N'_{data1}$  and  $N'_{data2}$  are the number of bits in the data fields of the slot format used for the current compressed mode, i.e. slot format A or B as defined in [2] corresponding to the Spreading Factor and the number of transmitted slots in use.

The number of bits corresponding to the gap for TrCh  $i$ , in each radio frame of its TTI is calculated using the number of bits to remove on each Physical Channel  $N_{TGL}[k]$ , where  $k$  is the radio frame number in the TTI.

For each radio frame  $k$  of the TTI,  $N_{TGL}[k]$  is given by the relation:

$$N_{TGL} = \begin{cases} \frac{TGL}{15} N'_{data,*} & \text{if } N_{first} + TGL \leq 15 \\ \frac{15 - N_{first}}{15} N'_{data,*} & \text{in first radio frame of the gap if } N_{first} + TGL > 15 \\ \frac{TGL - (15 - N_{first})}{15} N'_{data,*} & \text{in second radio frame of the gap if } N_{first} + TGL > 15 \end{cases}$$

$N_{first}$  and  $TGL$  are defined in section 4.4.

Note that  $N_{TGL}[k] = 0$  if radio frame  $k$  is not compressed.

#### 4.2.7.2.1 Determination of rate matching parameters for fixed positions of TrCHs

##### 4.2.7.2.1.1 Calculation of $\Delta N_{max}$ for normal mode and compressed mode by higher layer scheduling and spreading factor reduction

First an intermediate calculation variable  $N_{i,*}$  is calculated for all transport channels  $i$  by the following formula:

$$N_{i,*} = \frac{1}{F_i} \cdot \max_{l \in TFS(i)} N_{i,l}^{TTI}$$

The computation of the  $\Delta N_{i,l}^{TTI}$  parameters is then performed in for all TrCH  $i$  and all TF  $l$  by the following formula, where  $\Delta N_{i,*}$  is derived from  $N_{i,*}$  by the formula given at section 4.2.7:

$$\Delta N_{max} = F_i \cdot \Delta N_{i,*}$$

If  $\Delta N_{max} = 0$  then, for TrCH  $i$ , the output data of the rate matching is the same as the input data and the rate matching algorithm of section 4.2.7.5 does not need to be executed. In this case we have :

$$\forall l \in TFS(i) \Delta N_{i,l}^{TTI} = 0$$

If  $\Delta N_{max} \neq 0$  the parameters listed in sections 4.2.7.2.1.1 and 4.2.7.2.1.2 shall be used for determining  $e_{mi}$ ,  $e_{plus}$ , and  $e_{minus}$ .

#### 4.2.7.2.1.2 Calculations for compressed mode by puncturing:

Calculations of  $\Delta N_{i,max}^{TTI,m}$  for all TTI  $m$  within largest TTI, for all TrCh  $i$

First an intermediate calculation variable  $N_{i,*}^n$  is calculated for all transport channels  $i$  and all frames  $n$  in TTI  $m$  within the largest TTI, using the same formula as for normal mode above by replacing  $N_{i,l}^{TTI}$  by  $N_{i,l}^{TTI,m}$ , the number of bits in TTI  $m$ .

The computation of the  $\Delta N_{i,max}^{TTI,m}$  parameters is then performed for all TrCH  $i$  by the following formula,

$$\Delta N_{i,max}^{TTI,m} = \sum_{n=0}^{n=Fi} \Delta N_{i,*}^n$$

where all  $\Delta N_{i,*}^n$  are derived from  $N_{i,*}^n$  for all TrCh  $i$  and all frames  $n$  in TTI  $m$ , from the formula given at section 4.2.7 using  $N_{data,*}$  for the non compressed frames of TTI  $m$  and using  $N'_{data,*}$  instead of  $N_{data,*}$  for the compressed frames of TTI  $m$ .

Calculations of  $Np_{i,max}^n$  and  $Np_{i,max}^{TTI,m}$

Let  $Np_{i,max}^n$  be the number of bits to eliminate on TrCh  $i$  to create the gap for compressed mode, in each radio frame  $k$  of the TTI, calculated for the Transport Format Combination of TrCh  $i$ , in which the number of bits of TrCh  $i$  is at its maximum.

$Np_{i,max}^n$  is calculated for each radio frame  $k$  of the TTI in the following way.

Intermediate variables  $Z_i$  for  $i = 1$  to  $I$  are calculated using the formula (1) in 4.2.7, by replacing  $N_{data,j}$  by  $N_{TGI}[k]$ .

Then  $Np_{i,max}^n = (Z_i - Z_{i-1})$  for  $i = 1$  to  $I$

The total number of bits  $Np_{i,max}^{TTI,m}$  corresponding to the gaps for compressed mode for TrCh  $i$  in the TTI is calculated as:

$$Np_{i,max}^{TTI,m} = \sum_{n=0}^{Fi-1} Np_{i,max}^n$$

If  $\Delta N_{max} = Np_{i,max}^{TTI,m}$ , then, for TrCH  $i$ , the output data of the rate matching is the same as the input data and the rate matching algorithm of section 4.2.7.5 does not need to be executed. If  $\Delta N_{max} \neq Np_{i,max}^{TTI,m}$ , then, for TrCH  $i$ , the rate matching algorithm of section 4.2.7.5 needs to be executed.

$$\Delta N_{i,max}^{TTI,cm,m} = \Delta N_{i,max}^{TTI,m} - Np_{i,max}^{TTI,m}$$

#### 4.2.7.2.1.34 Determination of rate matching parameters for Uncoded and convolutionally encoded TrCHs

$$\Delta N_i = \Delta N_{max}$$

For compressed mode by puncturing,  $\Delta N_i$  is defined as:  $\Delta N_i = \Delta N_{i,max}^{TTI,cm,m}$ , instead of the previous relation.

$a=2$

$$N_{max} = \max_{l \in TFS(i)} N_{il}^{TTI}$$

For each transmission time interval of TrCH  $i$  with TF  $l$ , the rate-matching pattern is calculated with the algorithm in section 4.2.7.5. The following parameters are used as input:

$$X_i = N_{il}^{TTI}$$

$$e_{ini} = 1$$

$$e_{plus} = a \cdot N_{max}$$

$$e_{minus} = a \cdot |\Delta N_i|$$

Puncturing if  $\Delta N_i < 0$ , repetition otherwise. The values of  $\Delta N_{i,l}^{TTI}$  may be computed by counting repetitions or puncturing when the algorithm of section 4.2.7.5 is run.

#### 4.2.7.2.1.42\_ Determination of rate matching parameters for Turbo encoded TrCHs

If repetition is to be performed on turbo encoded TrCHs, i.e.  $\Delta N_{max} > 0$ , the parameters in section 4.2.7.2.1.1 are used.

If puncturing is to be performed, the parameters below shall be used. Index  $b$  is used to indicate systematic ( $b=1$ ), 1<sup>st</sup> parity ( $b=2$ ), and 2<sup>nd</sup> parity bit ( $b=3$ ).

$$a=2 \text{ when } b=2$$

$$a=1 \text{ when } b=3$$

The bits indicated by  $b=1$  shall not be punctured.

$$\Delta N_i = \begin{cases} \lfloor \Delta N_{max} / 2 \rfloor, & b = 2 \\ \lceil \Delta N_{max} / 2 \rceil, & b = 3 \end{cases}$$

In Compressed Mode by puncturing, the following relations are used instead of the previous ones:

$$\underline{\Delta N_i} = \underline{\lfloor \Delta N_{i,max}^{TTI,cm,m} / 2 \rfloor}, \quad b=2$$

$$\underline{\Delta N_i} = \underline{\lceil \Delta N_{i,max}^{TTI,cm,m} / 2 \rceil}, \quad b=3$$

$$N_{max} = \max_{l \in TFS(i)} (N_{il}^{TTI} / 3)$$

For each transmission time interval of TrCH  $i$  with TF  $l$ , the rate-matching pattern is calculated with the algorithm in section 4.2.7.5. The following parameters are used as input:

$$X_i = N_{il}^{TTI} / 3$$

$$e_{ini} = N_{max}$$

$$e_{plus} = a \cdot N_{max}$$

$$e_{minus} = a \cdot |\Delta N_i|$$

The values of  $\Delta N_{i,l}^{TTI}$  may be computed by counting repetitions or puncturing when the algorithm of section 4.2.7.5 is run.

#### 4.2.7.2.2 Determination of rate matching parameters for flexible positions of TrCHs

##### 4.2.7.2.2.1 Calculations for normal mode, compressed mode by higher layer scheduling, and compressed mode by spreading factor reduction

First an intermediate calculation variable  $N_{ij}$  is calculated for all transport channels  $i$  and all transport format combinations  $j$  by the following formula:



$$N_{i,j} = \frac{1}{F_i} \cdot N_{i,TF_i(j)}^{TTI}$$

Then rate matching ratios  $RF_i$  are calculated for each the transport channel  $i$  in order to minimise the number of DTX bits when the bit rate of the CCTrCH is maximum. The  $RF_i$  ratios are defined by the following formula:

$$RF_i = \frac{N_{data,*}}{\max_{j \in TFCS} \sum_{i=1}^{i=I} (RM_i \cdot N_{i,j})} \cdot RM_i$$

The computation of  $\Delta N_{i,l}^{TTI}$  parameters is then performed in two phases. In a first phase, tentative temporary values of  $\Delta N_{i,l}^{TTI}$  are computed, and in the second phase they are checked and corrected. The first phase, by use of the  $RF_i$  ratios, ensures that the number of DTX indication bits inserted is minimum when the CCTrCH bit rate is maximum, but it does not ensure that the maximum CCTrCH bit rate is not greater than  $N_{data,*}$  per 10ms. The latter condition is ensured through the checking and possible corrections carried out in the second phase.

At the end of the second phase, the latest value of  $\Delta N_{i,l}^{TTI}$  is the definitive value.

The first phase defines the tentative temporary  $\Delta N_{i,l}^{TTI}$  for all transport channel  $i$  and any of its transport format  $l$  by use of the following formula:

$$\Delta N_{i,l}^{TTI} = F_i \cdot \left[ \frac{RF_i \cdot N_{i,l}^{TTI}}{F_i} \right] - N_{i,l}^{TTI}$$

The second phase is defined by the following algorithm:

for all  $j$  in  $TFCS$  do -- for all TFC

$$D = \sum_{i=1}^{i=I} \frac{N_{i,TF_i(j)}^{TTI} + \Delta N_{i,TF_i(j)}^{TTI}}{F_i} \quad \text{-- CCTrCH bit rate (bits per 10ms) for TFC } l$$

if  $D > N_{data,*}$  then

for  $i = 1$  to  $I$  do -- for all TrCH

$$\Delta N = F_i \cdot \Delta N_{i,j} \quad \text{-- } \Delta N_{i,j} \text{ is derived from } N_{i,j} \text{ by the formula given at section 4.2.7.}$$

if  $\Delta N_{i,TF_i(j)}^{TTI} > \Delta N$  then

$$\Delta N_{i,TF_i(j)}^{TTI} = \Delta N$$

end-if

end-for

end-if

end-for

NOTE: The order in which the transport format combinations are checked does not change the final result.

If  $\Delta N_{i,l}^{TTI} = 0$  then, for TrCH  $i$  at TF  $l$ , the output data of the rate matching is the same as the input data and the rate matching algorithm of section 4.2.7.5 does not need to be executed.

If  $\Delta N_{i,l}^{TTI} \neq 0$  the parameters listed in sections 4.2.7.2.2.1 and 4.2.7.2.2.2 shall be used for determining  $e_{ini}$ ,  $e_{plus}$ , and  $e_{minus}$ .

#### 4.2.7.2.2.24 Determination of rate matching parameters for Uu uncoded and convolutionally encoded TrCHs

$$\Delta N_i = \Delta N_{il}^{TTI}$$

$$a=2$$

For each transmission time interval of TrCH  $i$  with TF  $l$ , the rate-matching pattern is calculated with the algorithm in section 4.2.7.5. The following parameters are used as input:

$$X_i = N_{il}^{TTI}$$

$$e_{ini} = 1$$

$$e_{plus} = a \cdot N_{il}^{TTI}$$

$$e_{minus} = a \cdot |\Delta N_i|$$

puncturing for  $\Delta N_i < 0$ , repetition otherwise.

#### 4.2.7.2.2.23 Determination of rate matching parameters for Turbo encoded TrCHs

If repetition is to be performed on turbo encoded TrCHs, i.e.  $\Delta N_{il}^{TTI} > 0$ , the parameters in section 4.2.7.2.2.1 are used.

If puncturing is to be performed, the parameters below shall be used. Index  $b$  is used to indicate systematic ( $b=1$ ), 1<sup>st</sup> parity ( $b=2$ ), and 2<sup>nd</sup> parity bit ( $b=3$ ).

$$a=2 \text{ when } b=2$$

$$a=1 \text{ when } b=3$$

The bits indicated by  $b=1$  shall not be punctured.

$$\Delta N_i = \begin{cases} \left\lfloor \frac{\Delta N_{il}^{TTI}}{2} \right\rfloor, & b=2 \\ \left\lfloor \frac{\Delta N_{il}^{TTI}}{2} \right\rfloor, & b=3 \end{cases}$$

For each transmission time interval of TrCH  $i$  with TF  $l$ , the rate-matching pattern is calculated with the algorithm in section 4.2.7.5. The following parameters are used as input:

$$X_i = N_{il}^{TTI} / 3N,$$

$$e_{ini} = X_i,$$

$$e_{plus} = a \cdot X_i$$

$$e_{minus} = a \cdot |\Delta N_i|$$

### 4.2.7.3 Bit separation and collection in uplink

The systematic bits (excluding bits for trellis termination) of turbo encoded TrCHs shall not be punctured. The systematic bit, first parity bit, and second parity bit in the bit sequence input to the rate matching block are therefore separated from each other. Puncturing is only applied to the parity bits and systematic bits used for trellis termination.

The bit separation function is transparent for uncoded TrCHs, convolutionally encoded TrCHs, and for turbo encoded TrCHs with repetition. The bit separation and bit collection are illustrated in figures 6 and 7.

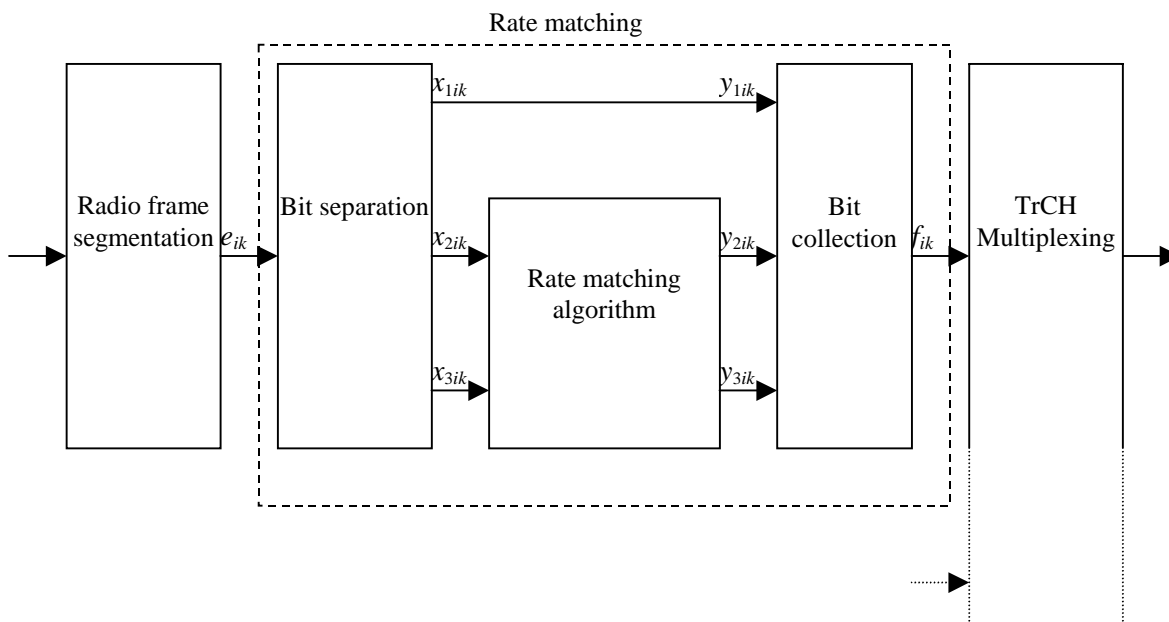

Figure 6: Puncturing of turbo encoded TrCHs

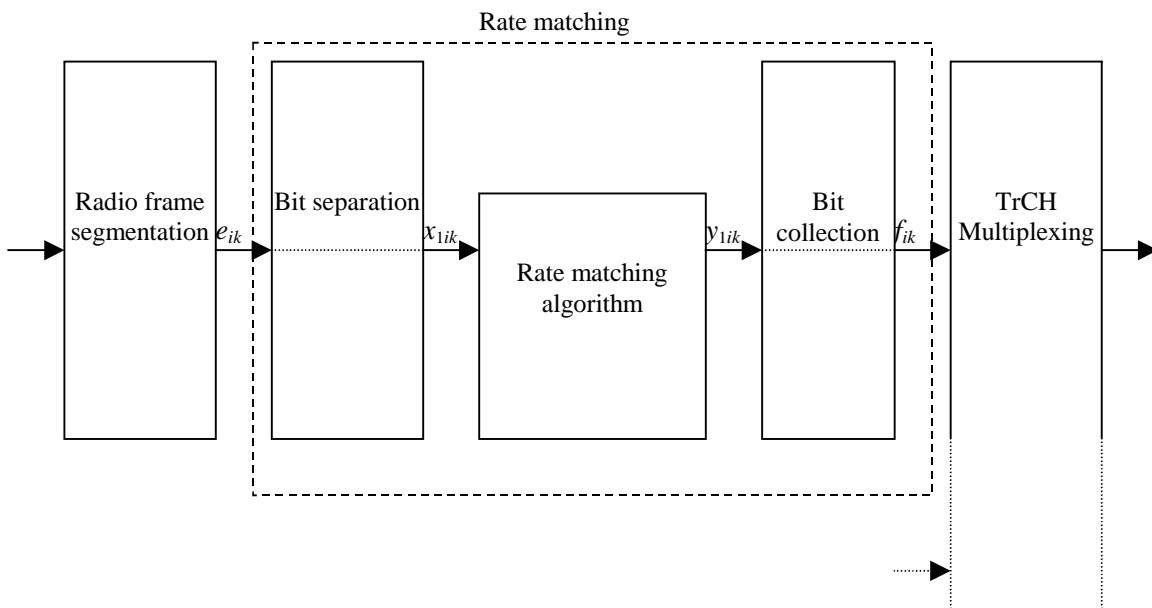

Figure 7: Rate matching for uncoded TrCHs, convolutionally encoded TrCHs, and for turbo encoded TrCHs with repetition.

The bit separation is dependent on the 1<sup>st</sup> interleaving and offsets are used to define the separation for different TTIs. The offsets  $\alpha_b$  for the systematic ( $b=1$ ) and parity bits ( $b \in \{2, 3\}$ ) are listed in table 4.

Table 4: TTI dependent offset needed for bit separation

TTI (ms)	$\alpha_1$	$\alpha_2$	$\alpha_3$
10, 40	0	1	2
20, 80	0	2	1

The bit separation is different for different radio frames in the TTI. A second offset is therefore needed. The radio frame number for TrCH  $i$  is denoted by  $n_i$ , and the offset by  $\beta_{n_i}$ .

**Table 5: Radio frame dependent offset needed for bit separation**

TTI (ms)	$\beta_0$	$\beta_1$	$\beta_2$	$\beta_3$	$\beta_4$	$\beta_5$	$\beta_6$	$\beta_7$
10	0	NA	NA	NA	NA	NA	NA	NA
20	0	1	NA	NA	NA	NA	NA	NA
40	0	1	2	0	NA	NA	NA	NA
80	0	1	2	0	1	2	0	1

#### 4.2.7.3.1 Bit separation

The bits input to the rate matching are denoted by  $e_{i1}, e_{i2}, e_{i3}, \dots, e_{iN_i}$ , where  $i$  is the TrCH number and  $N_i$  is the number of bits input to the rate matching block. Note that the transport format combination number  $j$  for simplicity has been left out in the bit numbering, i.e.  $N_i = N_{ij}$ . The bits after separation are denoted by  $x_{bi1}, x_{bi2}, x_{bi3}, \dots, x_{biX_i}$ . For turbo encoded TrCHs with puncturing,  $b$  indicates systematic, first parity, or second parity bit. For all other cases  $b$  is defined to be 1.  $X_i$  is the number of bits in each separated bit sequence. The relation between  $e_{ik}$  and  $x_{bik}$  is given below.

For turbo encoded TrCHs with puncturing:

$$x_{1,i,k} = e_{i,3(k-1)+1+(\alpha_1+\beta_{n_i}) \bmod 3} \quad k = 1, 2, 3, \dots, X_i \quad X_i = \lfloor N_i/3 \rfloor$$

$$x_{1,i,\lfloor N_i/3 \rfloor + k} = e_{i,3\lfloor N_i/3 \rfloor + k} \quad k = 1, \dots, N_i \bmod 3 \quad \text{Note: When } (N_i \bmod 3) = 0 \text{ this row is not needed.}$$

$$x_{2,i,k} = e_{i,3(k-1)+1+(\alpha_2+\beta_{n_i}) \bmod 3} \quad k = 1, 2, 3, \dots, X_i \quad X_i = \lfloor N_i/3 \rfloor$$

$$x_{3,i,k} = e_{i,3(k-1)+1+(\alpha_3+\beta_{n_i}) \bmod 3} \quad k = 1, 2, 3, \dots, X_i \quad X_i = \lfloor N_i/3 \rfloor$$

For uncoded TrCHs, convolutionally encoded TrCHs, and turbo encoded TrCHs with repetition:

$$x_{1,i,k} = e_{i,k} \quad k = 1, 2, 3, \dots, X_i \quad X_i = N_i$$

#### 4.2.7.3.2 Bit collection

The bits  $x_{bik}$  are input to the rate matching algorithm described in section 4.2.7.5. The bits output from the rate matching algorithm are denoted  $y_{bi1}, y_{bi2}, y_{bi3}, \dots, y_{biY_i}$ .

Bit collection is the inverse function of the separation. The bits after collection are denoted by  $z_{bi1}, z_{bi2}, z_{bi3}, \dots, z_{biY_i}$ .

After bit collection, the bits indicated as punctured are removed and the bits are then denoted by  $f_{i1}, f_{i2}, f_{i3}, \dots, f_{iV_i}$ , where  $i$  is the TrCH number and  $V_i = N_{ij} + \Delta N_{ij}$ . The relations between  $y_{bik}$ ,  $z_{bik}$ , and  $f_{ik}$  are given below.

For turbo encoded TrCHs with puncturing ( $Y_i = X_i$ ):

$$z_{i,3(k-1)+1+(\alpha_1+\beta_{n_i}) \bmod 3} = y_{1,i,k} \quad k = 1, 2, 3, \dots, Y_i$$

$$z_{i,3\lfloor N_i/3 \rfloor + k} = y_{1,i,\lfloor N_i/3 \rfloor + k} \quad k = 1, \dots, N_i \bmod 3 \quad \text{Note: When } (N_i \bmod 3) = 0 \text{ this row is not needed.}$$

$$z_{i,3(k-1)+1+(\alpha_2+\beta_{n_i}) \bmod 3} = y_{2,i,k} \quad k = 1, 2, 3, \dots, Y_i$$

$$z_{i,3(k-1)+1+(\alpha_3+\beta_{n_i}) \bmod 3} = y_{3,i,k} \quad k = 1, 2, 3, \dots, Y_i$$

After the bit collection, bits  $z_{i,k}$  with value  $\delta$ , where  $\delta \in \{0, 1\}$ , are removed from the bit sequence. Bit  $f_{i,1}$  corresponds to the bit  $z_{i,k}$  with smallest index  $k$  after puncturing, bit  $f_{i,2}$  corresponds to the bit  $z_{i,k}$  with second smallest index  $k$  after puncturing, and so on.

For uncoded TrCHs, convolutionally encoded TrCHs, and turbo encoded TrCHs with repetition:

$$z_{i,k} = y_{1,i,k} \quad k = 1, 2, 3, \dots, Y_i$$

When repetition is used,  $f_{i,k}=z_{i,k}$  and  $Y_i=V_i$ .

When puncturing is used,  $Y_i=X_i$  and bits  $z_{i,k}$  with value  $\delta$ , where  $\delta \neq \{0, 1\}$ , are removed from the bit sequence. Bit  $f_{i,1}$  corresponds to the bit  $z_{i,k}$  with smallest index  $k$  after puncturing, bit  $f_{i,2}$  corresponds to the bit  $z_{i,k}$  with second smallest index  $k$  after puncturing, and so on.

#### 4.2.7.4 Bit separation and collection in downlink

The systematic bits (excluding bits for trellis termination) of turbo encoded TrCHs shall not be punctured. The systematic bit, first parity bit, and second parity bit in the bit sequence input to the rate matching block are therefore separated from each other. Puncturing is only applied to the parity bits and systematic bits used for trellis termination.

The bit separation function is transparent for uncoded TrCHs, convolutionally encoded TrCHs, and for turbo encoded TrCHs with repetition. The bit separation and bit collection are illustrated in figures 8 and 9.

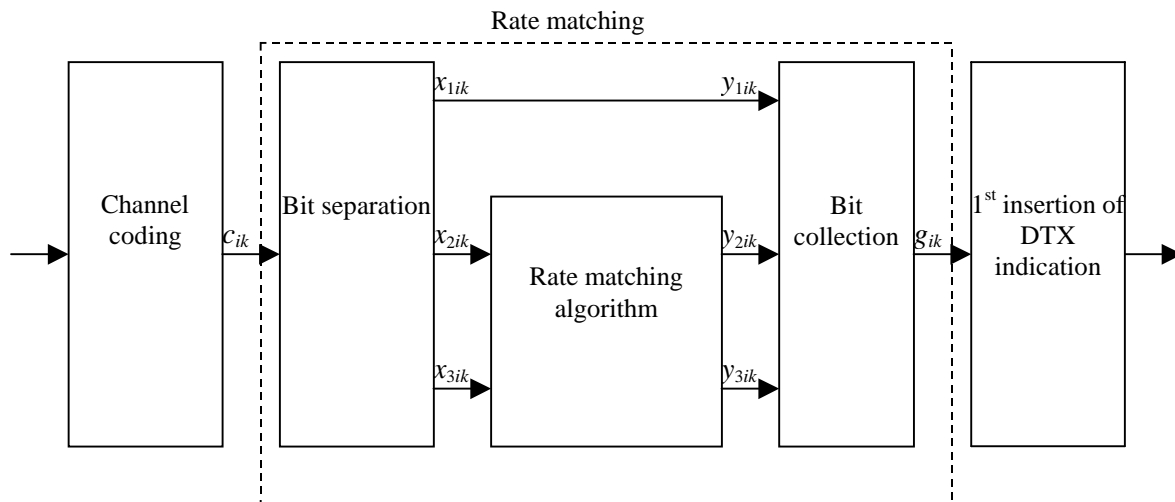

Figure 8: Puncturing of turbo encoded TrCHs

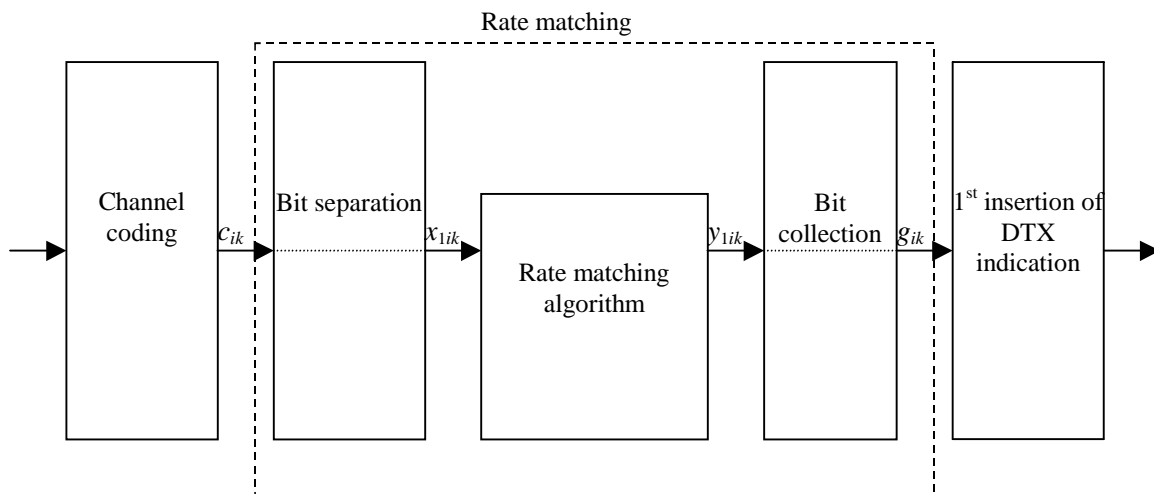

Figure 9: Rate matching for uncoded TrCHs, convolutionally encoded TrCHs, and for turbo encoded TrCHs with repetition.

#### 4.2.7.4.1 Bit separation

The bits input to the rate matching are denoted by  $c_{i1}, c_{i2}, c_{i3}, \dots, c_{iE_i}$ , where  $i$  is the TrCH number and  $E_i$  is the number of bits input to the rate matching block. Note that  $E_i$  is a multiple of 3 for turbo encoded TrCHs and that the transport format combination number  $j$  for simplicity has been left out in the bit numbering, i.e.  $E_i = N_{ij}$ . The bits after separation are denoted by  $x_{bi1}, x_{bi2}, x_{bi3}, \dots, x_{biX_i}$ . For turbo encoded TrCHs with puncturing,  $b$  indicates systematic, first parity, or second parity bit. For all other cases  $b$  is defined to be 1.  $X_i$  is the number of bits in each separated bit sequence. The relation between  $c_{ik}$  and  $x_{bik}$  is given below.

For turbo encoded TrCHs with puncturing:

$$x_{1,i,k} = c_{i,3(k-1)+1} \quad k = 1, 2, 3, \dots, X_i \quad X_i = E_i / 3$$

$$x_{2,i,k} = c_{i,3(k-1)+2} \quad k = 1, 2, 3, \dots, X_i \quad X_i = E_i / 3$$

$$x_{3,i,k} = c_{i,3(k-1)+3} \quad k = 1, 2, 3, \dots, X_i \quad X_i = E_i / 3$$

For uncoded TrCHs, convolutionally encoded TrCHs, and turbo encoded TrCHs with repetition:

$$x_{1,i,k} = c_{i,k} \quad k = 1, 2, 3, \dots, X_i \quad X_i = E_i$$

#### 4.2.7.4.2 Bit collection

The bits  $x_{bik}$  are input to the rate matching algorithm described in section 4.2.7.5. The bits output from the rate matching algorithm are denoted  $y_{bi1}, y_{bi2}, y_{bi3}, \dots, y_{biY_i}$ .

Bit collection is the inverse function of the separation. The bits after collection are denoted by  $z_{bi1}, z_{bi2}, z_{bi3}, \dots, z_{biY_i}$ . After bit collection, the bits indicated as punctured are removed and the bits are then denoted by  $g_{i1}, g_{i2}, g_{i3}, \dots, g_{iG_i}$ , where  $i$  is the TrCH number and  $G_i = N_{ij} + \Delta N_{ij}$ . The relations between  $y_{bik}$ ,  $z_{bik}$ , and  $g_{ik}$  are given below.

For turbo encoded TrCHs with puncturing ( $Y_i = X_i$ ):

$$z_{i,3(k-1)+1} = y_{1,i,k} \quad k = 1, 2, 3, \dots, Y_i$$

$$z_{i,3(k-1)+2} = y_{2,i,k} \quad k = 1, 2, 3, \dots, Y_i$$

$$z_{i,3(k-1)+3} = y_{3,i,k} \quad k = 1, 2, 3, \dots, Y_i$$

After the bit collection, bits  $z_{i,k}$  with value  $\delta$ , where  $\delta \notin \{0, 1\}$ , are removed from the bit sequence. Bit  $g_{i,1}$  corresponds to the bit  $z_{i,k}$  with smallest index  $k$  after puncturing, bit  $g_{i,2}$  corresponds to the bit  $z_{i,k}$  with second smallest index  $k$  after puncturing, and so on.

For uncoded TrCHs, convolutionally encoded TrCHs, and turbo encoded TrCHs with repetition:

$$z_{i,k} = y_{1,i,k} \quad k = 1, 2, 3, \dots, Y_i$$

When repetition is used,  $g_{i,k} = z_{i,k}$  and  $Y_i = G_i$ .

When puncturing is used,  $Y_i = X_i$  and bits  $z_{i,k}$  with value  $\delta$ , where  $\delta \notin \{0, 1\}$ , are removed from the bit sequence. Bit  $g_{i,1}$  corresponds to the bit  $z_{i,k}$  with smallest index  $k$  after puncturing, bit  $g_{i,2}$  corresponds to the bit  $z_{i,k}$  with second smallest index  $k$  after puncturing, and so on.

#### 4.2.7.5 Rate matching pattern determination

Denote the bits before rate matching by:

$x_{i1}, x_{i2}, x_{i3}, \dots, x_{iX_i}$ , where  $i$  is the TrCH number and  $X_i$  is the parameter given in sections 4.2.7.1 and 4.2.7.2.

The rate matching rule is as follows:

if puncturing is to be performed

$e = e_{ini}$       -- initial error between current and desired puncturing ratio

$m = 1$       -- index of current bit

do while  $m \leq X_i$

$e = e - e_{minus}$       -- update error

if  $e \leq 0$  then      -- check if bit number  $m$  should be punctured

set bit  $x_{i,m}$  to  $\delta$  where  $\delta \notin \{0, 1\}$

$e = e + e_{plus}$       -- update error

end if

$m = m + 1$       -- next bit

end do

else

$e = e_{ini}$       -- initial error between current and desired puncturing ratio

$m = 1$       -- index of current bit

do while  $m \leq X_i$

$e = e - e_{minus}$       -- update error

do while  $e \leq 0$       -- check if bit number  $m$  should be repeated

repeat bit  $x_{i,m}$

$e = e + e_{plus}$       -- update error

end do

$m = m + 1$       -- next bit

end do

end if

A repeated bit is placed directly after the original one.

## 4.2.9 Insertion of discontinuous transmission (DTX) indication bits

In the downlink, DTX is used to fill up the radio frame with bits. The insertion point of DTX indication bits depends on whether fixed or flexible positions of the TrCHs in the radio frame are used. It is up to the UTRAN to decide for each CcTrCH whether fixed or flexible positions are used during the connection. DTX indication bits only indicate when the transmission should be turned off, they are not transmitted.

### 4.2.9.1 1<sup>st</sup> insertion of DTX indication bits

This step of inserting DTX indication bits is used only if the positions of the TrCHs in the radio frame are fixed. With fixed position scheme a fixed number of bits is reserved for each TrCH in the radio frame.

The bits from rate matching are denoted by  $g_{i1}, g_{i2}, g_{i3}, \dots, g_{iG_i}$ , where  $G_i$  is the number of bits in one TTI of TrCH  $i$ .

Denote the number of bits in one radio frame of TrCH  $i$  by  $H_i$ . Denote  $D_i$  the number of bits output of the first DTX insertion block.

In normal or compressed mode by spreading factor reduction,  $H_i$  is constant and corresponds to the maximum number of bits from TrCH  $i$  in one radio frame for any transport format of TrCH  $i$ , and  $D_i = F_i * H_i$ .

In compressed mode by puncturing, additional puncturing is performed in the rate matching block. The empty positions resulting from the additional puncturing are used to insert p-bits in the first interleaving block, the DTX insertion is therefore limited to allow for later insertion of p-bits. Thus DTX bits are inserted until the total number of bits is  $D_i$  where  $D_i = F_i * H_i + \Delta N_{cm, i, max}^{TTI}$ , and  $H_i = N_{i,*} + \Delta N_{i,*}$ .

In compressed mode by higher layer scheduling, only a subset of the TFC Set is allowed. From this subset it is possible to derive which TFs on each TrCH that are allowed. The maximum number of bits belonging to one TTI of TrCH  $i$  for

the allowed TFs is denoted by  $X_i$ .  $H_i$  is then calculated as  $H_i = \left\lfloor \frac{X_i}{F_i} \right\rfloor$ , where  $F_i$  is the number of radio frames in a TTI

of TrCH  $i$ , and  $D_i = F_i * H_i$ .

The bits output from the DTX insertion are denoted by  $h_{i1}, h_{i2}, h_{i3}, \dots, h_{iD_i}$ .  $h_{i1}, h_{i2}, h_{i3}, \dots, h_{i(F_i H_i)}$ . Note that these bits are three valued. They are defined by the following relations:

$$h_{ik} = g_{ik} \quad k = 1, 2, 3, \dots, G_i$$

$$h_{ik} = \delta \quad k = G_i+1, G_i+2, G_i+3, \dots, F_i H_i D_i$$

where DTX indication bits are denoted by  $\delta$ . Here  $g_{ik} \in \{0, 1\}$  and  $\delta \notin \{0, 1\}$ .

### 4.2.9.2 2<sup>nd</sup> insertion of DTX indication bits

The DTX indication bits inserted in this step shall be placed at the end of the radio frame. Note that the DTX will be distributed over all slots after 2<sup>nd</sup> interleaving.

The bits input to the DTX insertion block are denoted by  $s_1, s_2, s_3, \dots, s_S$ , where  $S$  is the number of bits from TrCH multiplexing. The number of PhCHs is denoted by  $P$  and the number of bits in one radio frame, including DTX indication bits, for each PhCH is denoted by  $U$ . The number of available bits on the PhCH is denoted by  $N_{data}$  and  $N_{data} = 15N_{data1} + 15N_{data2}$ , where  $N_{data1}$  and  $N_{data2}$  are defined in [25.211]. In normal mode  $U = N_{data}$ .

In normal mode  $R = \frac{N_{data,*}}{P} = 15N_{data1} + 15N_{data2}$ , where  $N_{data1}$  and  $N_{data2}$  are defined in [2].

For compressed mode,  $N'_{data,*}$  is defined as  $N'_{data,*} = P(15N'_{data1} + 15N'_{data2}) - N'_{data1}$  and  $N'_{data2}$  are the number of bits in the data fields of the slot format used for the current compressed mode, i.e. slot format A or B as defined in [2] corresponding to the Spreading Factor and the number of transmitted slots in use.



In case of compressed mode by puncturing and fixed positions, DTX shall be inserted until  $N'_{data,*}$  bits, since the exact room for the gap is already reserved thanks to the earlier insertion of the p-bits. Therefore R is defined as  $R = N'_{data,*} / P$ .

In compressed mode by SF reduction and by higher layer scheduling, additional DTX shall be inserted if the transmission time reduction method does not exactly create a transmission gap of the desired TGL. The number of bits available to the CCTrCH in one radio frame in compressed mode by SF reduction and by higher layer scheduling is

denoted by  $N_{data,*}^{cm}$  and  $R = \frac{N_{data,*}^{cm}}{P}$ . ~~mode  $N_{data}$  is changed from the value in normal mode.~~ The exact value of

$N_{data,*}^{cm}$  is dependent on the TGL and the transmission time reduction method, which are signalled from higher layers. It can be calculated as  $N_{data,*}^{cm} = N'_{data,*} - N_{TGL}$ .  ~~$N_{TGL}$  is the number of bits that are located within the transmission gap is denoted  $N_{TGL}$  and defined as:~~

$$N_{TGL} = \begin{cases} \frac{TGL}{15} N'_{data,*} - \frac{TGL}{15} N_{data}, & \text{if } N_{first} + TGL \leq 15 \\ \frac{15 - N_{first}}{15} N'_{data,*} - \frac{15 - N_{first}}{15} N_{data}, & \text{in first frame if } N_{first} + TGL > 15 \\ \frac{TGL - (15 - N_{first})}{15} N'_{data,*} - \frac{TGL - (15 - N_{first})}{15} N_{data}, & \text{in second frame if } N_{first} + TGL > 15 \end{cases}$$

$N_{first}$  and TGL are defined in Section 4.4.

~~In compressed mode  $U = N_{data} - N_{TGL}$ .~~

The bits output from the DTX insertion block are denoted by  $w_1, w_2, w_3, \dots, w_{(PR)}$   ~~$w_1, w_2, w_3, \dots, w_{(PU)}$~~ . Note that these bits are four valued in case of compressed mode by puncturing, and three valued otherwise. They are defined by the following relations:

$$w_k = s_k \quad k = 1, 2, 3, \dots, S$$

$$w_k = \delta \quad k = S+1, S+2, S+3, \dots, PUR$$

where DTX indication bits are denoted by  $\delta$ . Here  $s_k \in \{0, 1, p\}$  and  $\delta \in \{0, 1\}$ .

## 4.2.10 Physical channel segmentation

When more than one PhCH is used, physical channel segmentation divides the bits among the different PhCHs. The bits input to the physical channel segmentation are denoted by  $x_1, x_2, x_3, \dots, x_Y$ , where  $Y$  is the number of bits input to the physical channel segmentation block. The number of PhCHs is denoted by  $P$ .

The bits after physical channel segmentation are denoted  $u_{p1}, u_{p2}, u_{p3}, \dots, u_{pU}$ , where  $p$  is PhCH number and  $U$  is the number of bits in one radio frame for each PhCH, i.e.  $U = (Y - N_{TGL}) / P$  for compressed mode by puncturing, and  $U = \frac{Y}{P}$  otherwise. The relation between  $x_k$  and  $u_{pk}$  is given below.

For all modes, some bits of the input flow are mapped to each code until the number of bits on the code is  $V$ . For modes other than compressed mode by puncturing, all bits of the input flow are taken to be mapped to the codes. For compressed mode by puncturing, only the bits of the input flow not corresponding to bits  $p$  are taken to be mapped to the codes, each bit  $p$  is removed to ensure creation the gap required by the compressed mode, as described below.

Bits on first PhCH after physical channel segmentation:

$$u_{1k} = x_k \quad u_{1,k} \equiv x_{i, f(k)} \quad k = 1, 2, \dots, U$$

Bits on second PhCH after physical channel segmentation:

$$u_{2k} = x_{(k+U)} \quad u_{2,k} \equiv x_{i, f(k+U)} \quad k = 1, 2, \dots, U$$

...

Bits on the  $P^{\text{th}}$  PhCH after physical channel segmentation:

$$u_{Pk} = x_{(k+(P-1)U)} \quad u_{P,k} \equiv x_{i, f(k+(P-1)U)} \quad k = 1, 2, \dots, U$$

where  $f$  is such that :

- for modes other than compressed mode by puncturing,  $x_{i, f(k)} = x_{i, k}$ , i.e.  $f(k) = k$ , for all  $k$ .
- for compressed mode by puncturing, bit  $u_{1,1}$  corresponds to the bit  $x_{i,k}$  with smallest index  $k$  when the bits  $p$  are not counted, bit  $u_{1,2}$  corresponds to the bit  $x_{i,k}$  with second smallest index  $k$  when the bits  $p$  are not counted, and so on for bits  $u_{1,3}, \dots, u_{1,V}, u_{2,1}, u_{2,2}, \dots, u_{2,V}, \dots, u_{P,1}, u_{P,2}, \dots, u_{P,V}$ .

### 4.2.10.1 Relation between input and output of the physical segmentation block in uplink

The bits input to the physical segmentation are denoted by  $s_1, s_2, s_3, \dots, s_S$ . Hence,  $x_k = s_k$  and  $Y = S$ .

### 4.2.10.2 Relation between input and output of the physical segmentation block in downlink

The bits input to the physical segmentation are denoted by  $w_1, w_2, w_3, \dots, w_{(PU)}$ . Hence,  $x_k = w_k$  and  $Y = PU$ .

<b>CHANGE REQUEST</b>		<small>Please see embedded help file at the bottom of this page for instructions on how to fill in this form correctly.</small>
<b>25.212</b>	<b>CR 044</b>	Current Version: <b>3.1.0</b>
<small>GSM (AA.BB) or 3G (AA.BBB) specification number ↑</small>		<small>↑ CR number as allocated by MCC support team</small>
For submission to: <b>RAN #7</b> <small>list expected approval meeting # here ↑</small>	for approval <input checked="" type="checkbox"/> for information <input type="checkbox"/>	strategic <input type="checkbox"/> non-strategic <input type="checkbox"/> <small>(for SMG use only)</small>

Form: CR cover sheet, version 2 for 3GPP and SMG The latest version of this form is available from: ftp://ftp.3gpp.org/Information/CR-Form-v2.doc

**Proposed change affects:** (U)SIM  ME  UTRAN / Radio  Core Network   
(at least one should be marked with an X)

**Source:** TSG RAN WG1 **Date:** 21-Jan-2000

**Subject:** Modification of Turbo code internal interleaver

**Work item:**

<b>Category:</b> <small>(only one category shall be marked with an X)</small>	F Correction <input type="checkbox"/>	<b>Release:</b>	Phase 2 <input type="checkbox"/>
	A Corresponds to a correction in an earlier release <input type="checkbox"/>		Release 96 <input type="checkbox"/>
	B Addition of feature <input checked="" type="checkbox"/>		Release 97 <input type="checkbox"/>
	C Functional modification of feature <input type="checkbox"/>		Release 98 <input type="checkbox"/>
	D Editorial modification <input type="checkbox"/>		Release 99 <input checked="" type="checkbox"/>
			Release 00 <input type="checkbox"/>

**Reason for change:** Addition of Turbo code internal interleaver for smaller block size from 40-bit to 319-bit

**Clauses affected:** 4.2.3.2.3 of 25.212

<b>Other specs affected:</b>	Other 3G core specifications <input type="checkbox"/>	→ List of CRs:	
	Other GSM core specifications <input type="checkbox"/>	→ List of CRs:	
	MS test specifications <input type="checkbox"/>	→ List of CRs:	
	BSS test specifications <input type="checkbox"/>	→ List of CRs:	
	O&M specifications <input type="checkbox"/>	→ List of CRs:	

**Other comments:**



help.doc

<----- double-click here for help and instructions on how to create a CR.

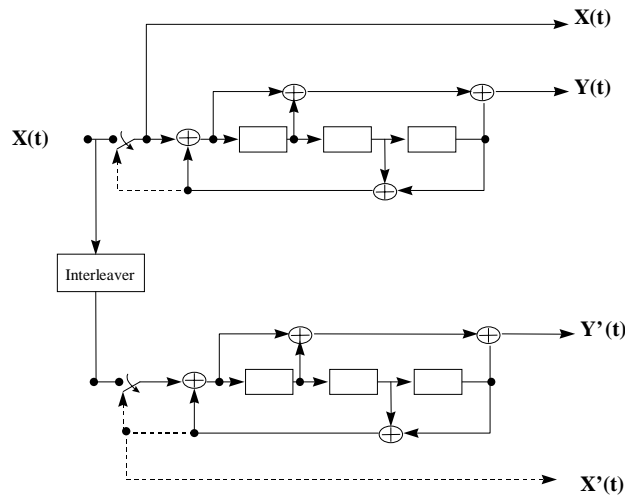

**Figure 4: Structure of the 8 state PCCC encoder (dotted lines effective for trellis termination only)**

The initial value of the shift registers of the PCCC encoder shall be all zeros.

The output of the PCCC encoder is punctured to produce coded bits corresponding to the desired code rate. For rate 1/3, none of the systematic or parity bits are punctured, and the output sequence is X(0), Y(0), Y'(0), X(1), Y(1), Y'(1), etc.

4.2.3.2.2 Trellis termination for Turbo coding

Trellis termination is performed by taking the tail bits from the shift register feedback after all information bits are encoded. Tail bits are added after the encoding of information bits.

The first three tail bits shall be used to terminate the first constituent encoder (upper switch of figure 4 in lower position) while the second constituent encoder is disabled. The last three tail bits shall be used to terminate the second constituent encoder (lower switch of figure 4 in lower position) while the first constituent encoder is disabled.

The transmitted bits for trellis termination shall then be

$$X(t) Y(t) X(t+1) Y(t+1) X(t+2) Y(t+2) X'(t) Y'(t) X'(t+1) Y'(t+1) X'(t+2) Y'(t+2).$$

4.2.3.2.3 Turbo code internal interleaver

Figure 5 depicts the overall 8 state PCCC Turbo coding scheme including Turbo code internal interleaver. The Turbo code internal interleaver consists of mother interleaver generation and pruning. For arbitrary given block length K, one mother interleaver is selected from the 134-163 mother interleavers set. The generation scheme of mother interleaver is described in section 4.2.3.2.3.1. After the mother interleaver generation, *l*-bits are pruned in order to adjust the mother interleaver to the block length K. Tail bits T<sub>1</sub> and T<sub>2</sub> are added for constituent encoders RSC1 and RSC2, respectively. The definition of *l* is shown in section 4.2.3.2.3.2.

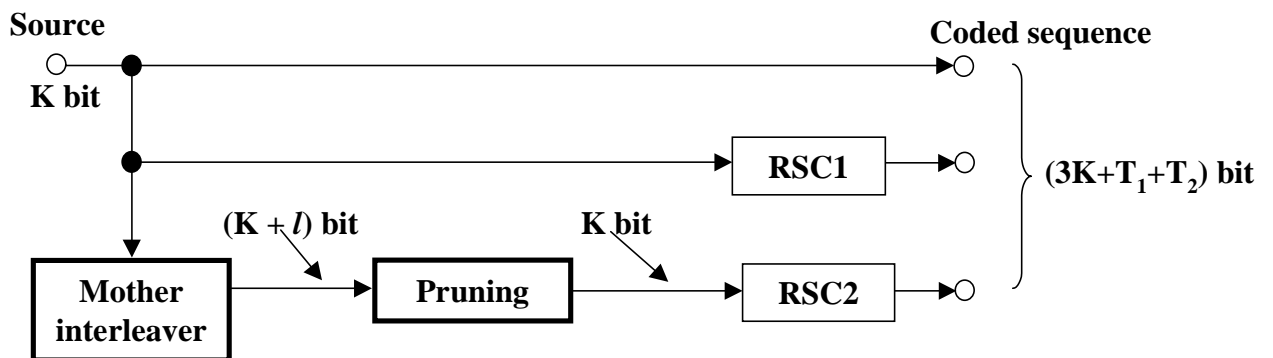

**Figure 5: Overall 8 State PCCC Turbo Coding**

## 4.2.3.2.3.1 Mother interleaver generation

The interleaving consists of three stages. In first stage, the input sequence is written into the rectangular matrix row by row. The second stage is intra-row permutation. The third stage is inter-row permutation. The three-stage permutations are described as follows, the input block length is assumed to be  $K$  (~~32040~~ to 5114 bits).

**First Stage:**

(1) Determine the number of rows  $R$  such that

$$R = 5 \text{ (} K = 40 \text{ to } 159 \text{ bits)}$$

$$R = 10 \text{ (} K = 160 \text{ to } 200 \text{ and } 481 \text{ to } 530 \text{ bits; Case 1)}$$

$$R = 20 \text{ (} K = \text{any other block lengths except } 481 \text{ to } 530 \text{ bits; Case 2)}$$

(2) Determine the number of columns  $C$  such that

$$\text{if } K = 481 \text{ to } 530 \text{ then Case 1; } C = p = 53$$

$$\text{else Case 2;}$$

(i) find minimum prime  $p$  such that,

$$0 < (p+1) - K/R,$$

(ii) if  $(0 < p - K/R)$  then go to (iii),

$$\text{else } C = p+1.$$

(iii) if  $(0 < p-1 - K/R)$  then  $C = p-1$ ,

$$\text{else } C = p.$$

(3) The input sequence of the interleaver is written into the  $R \times C$  rectangular matrix row by row starting from row 0.

**Second Stage:****A. If  $C = p$** 

(A-1) Select a primitive root  $g_0$  from table 2.

(A-2) Construct the base sequence  $c(i)$  for intra-row permutation as:

$$c(i) = [g_0 \times c(i-1)] \bmod p, \quad i = 1, 2, \dots, (p-2), \quad c(0) = 1.$$

(A-3) Select the minimum prime integer set  $\{q_j\}$  ( $j=1, 2, \dots, R-1$ ) such that

$$\text{g.c.d}\{q_j, p-1\} = 1$$

$$q_j > 6$$

$$q_j > q_{(j-1)}$$

where g.c.d. is greatest common divider. And  $q_0 = 1$ .

(A-4) The set  $\{q_j\}$  is permuted to make a new set  $\{p_j\}$  such that

$$p_{P(j)} = q_j, \quad j = 0, 1, \dots, R-1,$$

where  $P(j)$  is the inter-row permutation pattern defined in the third stage.

(A-5) Perform the  $j$ -th ( $j = 0, 1, 2, \dots, R-1$ ) intra-row permutation as:

$$c_j(i) = c([i \times p_j] \bmod (p-1)), \quad i = 0, 1, 2, \dots, (p-2), \quad \text{and } c_j(p-1) = 0,$$

where  $c_j(i)$  is the input bit position of  $i$ -th output after the permutation of  $j$ -th row.

**B. If  $C = p+1$**

(B-1) Same as case A-1.

(B-2) Same as case A-2.

(B-3) Same as case A-3.

(B-4) Same as case A-4.

(B-5) Perform the  $j$ -th ( $j = 0, 1, 2, \dots, R-1$ ) intra-row permutation as:

$$c_j(i) = c([i \times p_j] \bmod (p-1)), \quad i = 0, 1, 2, \dots, (p-2), \quad c_j(p-1) = 0, \text{ and } c_j(p) = p,$$

(B-6) If ( $K = C \times R$ ) then exchange  $c_{R-1}(p)$  with  $c_{R-1}(0)$ .

where  $c_j(i)$  is the input bit position of  $i$ -th output after the permutation of  $j$ -th row.

### C. If $C = p-1$

(C-1) Same as case A-1.

(C-2) Same as case A-2.

(C-3) Same as case A-3.

(C-4) Same as case A-4.

(C-5) Perform the  $j$ -th ( $j = 0, 1, 2, \dots, R-1$ ) intra-row permutation as:

$$c_j(i) = c([i \times p_j] \bmod (p-1)) - 1, \quad i = 0, 1, 2, \dots, (p-2),$$

where  $c_j(i)$  is the input bit position of  $i$ -th output after the permutation of  $j$ -th row.

### Third Stage:

(1) Perform the inter-row permutation based on the following  $P(j)$  ( $j=0, 1, \dots, R-1$ ) patterns, where  $P(j)$  is the original row position of the  $j$ -th permuted row.

$P_A$ : {19, 9, 14, 4, 0, 2, 5, 7, 12, 18, 10, 8, 13, 17, 3, 1, 16, 6, 15, 11} for  $R = 20$

$P_B$ : {19, 9, 14, 4, 0, 2, 5, 7, 12, 18, 16, 13, 17, 15, 3, 1, 6, 11, 8, 10} for  $R = 20$

$P_C$ : {9, 8, 7, 6, 5, 4, 3, 2, 1, 0} for  $R = 10$

$P_D$ : {4, 3, 2, 1, 0} for  $R = 5$

The usage of these patterns is as follows:

Block length  $K$ :  $P(j)$

40 to 159-bit:  $P_D$

160 to 200-bit:  $P_C$

201~~320~~ to 480-bit:  $P_A$

481 to 530-bit:  $P_C$

531 to 2280-bit:  $P_A$

2281 to 2480-bit:  $P_B$

2481 to 3160-bit:  $P_A$

3161 to 3210-bit:  $P_B$

3211 to 5114-bit:  $P_A$

(2) The output of the mother interleaver is the sequence read out column by column from the permuted  $R \times C$  matrix starting from column 0.

Table 2: Table of prime  $p$  and associated primitive root  $g_0$ 

$p$	$g_0$	$p$	$g_0$	$p$	$g_0$	$p$	$g_0$	$p$	$g_0$
7	3	47	5	101	2	157	5	223	3
11	2	53	2	103	5	163	2	227	2
13	2	59	2	107	2	167	5	229	6
17	3	61	2	109	6	173	2	233	3
19	2	67	2	113	3	179	2	239	7
23	5	71	7	127	3	181	2	241	7
29	2	73	5	131	2	191	19	251	6
31	3	79	3	137	3	193	5	257	3
37	2	83	2	139	2	197	2		
41	6	89	3	149	2	199	3		
43	3	97	5	151	6	211	2		

$p$	$g_0$	$p$	$g_0$	$p$	$g_0$	$p$	$g_0$	$p$	$g_0$
17	3	59	2	103	5	157	5	211	2
19	2	64	2	107	2	163	2	223	3
23	5	67	2	109	6	167	5	227	2
29	2	71	7	113	3	173	2	229	6
31	3	73	5	127	3	179	2	233	3
37	2	79	3	131	2	181	2	239	7
41	6	83	2	137	3	191	19	241	7
43	3	89	3	139	2	193	5	251	6
47	5	97	5	149	2	197	2	257	3
53	2	101	2	151	6	199	3		

## 4.2.3.2.3.2 Definition of number of pruning bits

The output of the mother interleaver is pruned by deleting the  $l$ -bits in order to adjust the mother interleaver to the block length  $K$ , where the deleted bits are non-existent bits in the input sequence. The pruning bits number  $l$  is defined as:

$$l = R \times C - K,$$

where  $R$  is the row number and  $C$  is the column number defined in section 4.2.3.2.3.1.





## CHANGE REQUEST

Please see embedded help file at the bottom of this page for instructions on how to fill in this form correctly.

**25.212 CR 045**

Current Version: **3.1.0**

GSM (AA.BB) or 3G (AA.BBB) specification number ↑

↑ CR number as allocated by MCC support team

For submission to: **RAN #7**  
List expected approval meeting # here ↑

for approval   
for information

strategic   
non-strategic  (for SMG use only)

Form: CR cover sheet, version 2 for 3GPP and SMG The latest version of this form is available from: <ftp://ftp.3gpp.org/Information/CR-Form-v2.doc>

**Proposed change affects:**  
(at least one should be marked with an X)

(U)SIM  ME  UTRAN / Radio  Core Network

**Source:** TSG RAN WG1

**Date:** 21 Feb 2000

**Subject:** Editorial corrections

**Work item:**

**Category:**

F Correction   
A Corresponds to a correction in an earlier release   
B Addition of feature   
C Functional modification of feature   
D Editorial modification

(only one category shall be marked with an X)

**Release:**

Phase 2   
Release 96   
Release 97   
Release 98   
Release 99   
Release 00

**Reason for change:**

Editorial corrections and clarifications

**Clauses affected:**

4.2.2.2, 4.2.4, 4.2.5.2, 4.2.6, 4.2.6.1, 4.2.7, 4.2.7.2.2.2, 4.2.7.3, 4.2.7.4, 4.2.7.5, 4.4.1

**Other specs affected:**

Other 3G core specifications  → List of CRs:  
Other GSM core specifications  → List of CRs:  
MS test specifications  → List of CRs:  
BSS test specifications  → List of CRs:  
O&M specifications  → List of CRs:

**Other comments:**

#### 4.2.2.2 Code block segmentation

Segmentation of the bit sequence from transport block concatenation is performed if  $X_i > Z$ . The code blocks after segmentation are of the same size. The number of code blocks on TrCH  $i$  is denoted by  $C_i$ . If the number of bits input to the segmentation,  $X_i$ , is not a multiple of  $C_i$ , filler bits are added to the last block. The filler bits are transmitted and they are always set to 0. The maximum code block sizes are:

convolutional coding:  $Z = 504$

turbo coding:  $Z = 5114$

no channel coding:  $Z = \text{unlimited}$

The bits output from code block segmentation are denoted by  $O_{ir1}, O_{ir2}, O_{ir3}, \dots, O_{irK_i}$ , where  $i$  is the TrCH number,  $r$  is the code block number, and  $K_i$  is the number of bits.

Number of code blocks:  $C_i = \lceil X_i / Z \rceil$

Number of bits in each code block:  $K_i = \lceil X_i / C_i \rceil$

Number of filler bits:  $Y_i = C_i K_i - X_i$

If  $X_i \leq Z$ , then  $O_{i1k} = x_{ik}$ , and  $K_i = X_i$ .

If  $X_i \geq Z$ , then

$$O_{i1k} = x_{ik} \quad k = 1, 2, \dots, K_i$$

$$O_{i2k} = x_{i,(k+K_i)} \quad k = 1, 2, \dots, K_i$$

$$O_{i3k} = x_{i,(k+2K_i)} \quad k = 1, 2, \dots, K_i$$

...

$$O_{iC_i k} = x_{i,(k+(C_i-1)K_i)} \quad k = 1, 2, \dots, K_i - Y_i$$

$$O_{iC_i k} = 0 \quad k = (K_i - Y_i) + 1, (K_i - Y_i) + 2, \dots, K_i$$

## 4.2.4 Radio frame size equalisation

Radio frame size equalisation is padding the input bit sequence in order to ensure that the output can be segmented in  $F_i$  data segments of same size as described in section 4.1.64.2.7. Radio frame size equalisation is only performed in the UL (DL rate matching output block length is always an integer multiple of  $F_i$ )

The input bit sequence to the radio frame size equalisation is denoted by  $c_{i1}, c_{i2}, c_{i3}, \dots, c_{iE_i}$ , where  $i$  is TrCH number and  $E_i$  the number of bits. The output bit sequence is denoted by  $t_{i1}, t_{i2}, t_{i3}, \dots, t_{iT_i}$ , where  $T_i$  is the number of bits. The output bit sequence is derived as follows:

$$t_{ik} = c_{ik}, \text{ for } k = 1 \dots E_i \text{ and}$$

$$t_{ik} = \{0, 1\} \text{ for } k = E_i + 1 \dots T_i, \text{ if } E_i < T_i$$

where

$$T_i = F_i * N_i \text{ and}$$

$$N_i = \left\lfloor \frac{E_i - 1}{F_i} \right\rfloor + 1, N_i = \left\lceil \frac{E_i}{F_i} \right\rceil \text{ is the number of bits per segment after size equalisation.}$$

#### 4.2.5.2 Relation between input and output of 1<sup>st</sup> interleaving in downlink

If fixed positions of the TrCHs in a radio frame is used then the bits input to the 1<sup>st</sup> interleaving are denoted by  $h_{i1}, h_{i2}, h_{i3}, \dots, h_{i(F_i H_i)}$ , where  $i$  is the TrCH number. Hence,  $x_{ik} = h_{ik}$  and  $X_i = F_i H_i$ .

If flexible positions of the TrCHs in a radio frame is used then the bits input to the 1<sup>st</sup> interleaving are denoted by  $g_{i1}, g_{i2}, g_{i3}, \dots, g_{iG_i}$ , where  $i$  is the TrCH number. Hence,  $x_{ik} = g_{ik}$  and  $X_i = G_i$ .

The bits output from the 1<sup>st</sup> interleaving are denoted by  $q_{i1}, q_{i2}, q_{i3}, \dots, q_{iQ_i}$ , where  $i$  is the TrCH number and  $Q_i$  is the number of bits. Hence,  $q_{ik} = y_{ik}$ ,  $Q_i = F_i H_i$  if fixed positions are used, and  $Q_i = G_i$  if flexible positions are used.

#### 4.2.6 Radio frame segmentation

When the transmission time interval is longer than 10 ms, the input bit sequence is segmented and mapped onto consecutive  $F_i$  radio frames. Following rate matching in the DL and radio frame size equalisation in the UL the input bit sequence length is guaranteed to be an integer multiple of  $F_i$ .

The input bit sequence is denoted by  $x_{i1}, x_{i2}, x_{i3}, \dots, x_{iX_i}$  where  $i$  is the TrCH number and  $X_i$  is the number bits. The  $F_i$  output bit sequences per TTI are denoted by  $y_{i,n_i1}, y_{i,n_i2}, y_{i,n_i3}, \dots, y_{i,n_iY_i}$  where  $n_i$  is the radio frame number in current TTI and  $Y_i$  is the number of bits per radio frame for TrCH  $i$ . The output sequences are defined as follows:

$$y_{i,n_i,k} = x_{i,((n_i-1)Y_i)+k}, n_i = 1 \dots F_i, k = 1 \dots Y_i$$

where

$Y_i = (X_i / F_i)$  is the number of bits per segment,

~~$x_{ik}$  is the  $k^{\text{th}}$  bit of the input bit sequence and~~

~~$y_{i,n_i,k}$  is the  $k^{\text{th}}$  bit of the output bit sequence corresponding to the  $n^{\text{th}}$  radio frame~~

The  $n_i$ -th segment is mapped to the  $n_i$ -th radio frame of the transmission time interval.

##### 4.2.6.1 Relation between input and output of the radio frame segmentation block in uplink

The input bit sequence to the radio frame segmentation is denoted by  $d_{i1}, d_{i2}, d_{i3}, \dots, d_{iT_i}$ , where  $i$  is the TrCH number and  $T_i$  the number of bits. Hence,  $x_{ik} = d_{ik}$  and  $X_i = T_i$ .

The output bit sequence corresponding to radio frame  $n_i$  is denoted by  $e_{i1}, e_{i2}, e_{i3}, \dots, e_{iN_i}$ , where  $i$  is the TrCH number and  $N_i$  is the number of bits. Hence,  $e_{i,k} = y_{i,n_i,k}$  and  $N_i = Y_i$ .

## 4.2.7 Rate matching

Rate matching means that bits on a transport channel are repeated or punctured. Higher layers assign a rate-matching attribute for each transport channel. This attribute is semi-static and can only be changed through higher layer signalling. The rate-matching attribute is used when the number of bits to be repeated or punctured is calculated.

The number of bits on a transport channel can vary between different transmission time intervals. In the downlink the transmission is interrupted if the number of bits is lower than maximum. When the number of bits between different transmission time intervals in uplink is changed, bits are repeated or punctured to ensure that the total bit rate after TrCH multiplexing is identical to the total channel bit rate of the allocated dedicated physical channels.

If no bits are input to the rate matching for all TrCHs within a CCTrCH, the rate matching shall output no bits for all TrCHs within the CCTrCH and no uplink DPDCH will be selected in the case of uplink rate matching.

### Notation used in section 4.2.7 and subsections:

$N_{ij}$ : For uplink: Number of bits in a radio frame before rate matching on TrCH  $i$  with transport format combination  $j$ .

\_\_\_\_\_ For downlink : An intermediate calculation variable (not an integer but a multiple of 1/8).

$N_{il}^{TTI}$  : Number of bits in a transmission time interval before rate matching on TrCH  $i$  with transport format  $l$ .  
Used in downlink only.

$\Delta N_{ij}$  : For uplink: If positive - number of bits that should be repeated in each radio frame on TrCH  $i$  with transport format combination  $j$ .

If negative - number of bits that should be punctured in each radio frame on TrCH  $i$  with transport format combination  $j$ .

\_\_\_\_\_ For downlink : An intermediate calculation variable (not an integer but a multiple of 1/8).

$\Delta N_{il}^{TTI}$  : If positive - number of bits to be repeated in each transmission time interval on TrCH  $i$  with transport format  $j$ .

\_\_\_\_\_ If negative - number of bits to be punctured in each transmission time interval on TrCH  $i$  with transport format  $j$ .

Used in downlink only.

$RM_i$ : Semi-static rate matching attribute for transport channel  $i$ . Signalled from higher layers.

$PL$ : Puncturing limit for uplink. This value limits the amount of puncturing that can be applied in order to avoid multicode or to enable the use of a higher spreading factor. Signalled from higher layers.

$N_{data,j}$ : Total number of bits that are available for the CCTrCH in a radio frame with transport format combination  $j$ .

$I$ : Number of TrCHs in the CCTrCH.

$Z_{ij}$ : Intermediate calculation variable.

$F_i$ : Number of radio frames in the transmission time interval of TrCH  $i$ .

$n_i$ : Radio frame number in the transmission time interval of TrCH  $i$  ( $0 \leq n_i < F_i$ ).

$q$ : Average puncturing or repetition distance (normalised to only show the remaining rate matching on top of an integer number of repetitions). Used in uplink only.

$I_F(n_i)$ : The inverse interleaving function of the 1<sup>st</sup> interleaver (note that the inverse interleaving function is identical to the interleaving function itself for the 1<sup>st</sup> interleaver). Used in uplink only.

$S(n_i)$ : The shift of the puncturing or repetition pattern for radio frame  $n_i$ . Used in uplink only.

- $TF_i(j)$ : Transport format of TrCH  $i$  for the transport format combination  $j$ .
- $TFS(i)$  The set of transport format indexes  $l$  for TrCH  $i$ .
- $TFCS$  The set of transport format combination indexes  $j$ .
- $e_{ini}$  Initial value of variable  $e$  in the rate matching pattern determination algorithm of section 4.2.7.5.
- $e_{plus}$  Increment of variable  $e$  in the rate matching pattern determination algorithm of section 4.2.7.5.
- $e_{minus}$  Decrement of variable  $e$  in the rate matching pattern determination algorithm of section 4.2.7.5.
- $b$ : Indicates systematic and parity bits
- $b=1$ : Systematic bit.  $X(t)$  in section 4.2.3.2.1.
- $b=2$ : 1<sup>st</sup> parity bit (from the upper Turbo constituent encoder).  $Y(t)$  in section 4.2.3.2.1.
- $b=3$ : 2<sup>nd</sup> parity bit (from the lower Turbo constituent encoder).  $Y'(t)$  in section 4.2.3.2.1.

The \* (star) notation is used to replace an index  $x$  when the indexed variable  $X_x$  does not depend on the index  $x$ . In the left wing of an assignment the meaning is that " $X_* = Y$ " is equivalent to "**for all  $x$  do  $X_x = Y$** ". In the right wing of an assignment, the meaning is that " $Y = X_*$ " is equivalent to "**take any  $x$  and do  $Y = X_x$** ".

The following relations, defined for all TFC  $j$ , are used when calculating the rate matching parameters:

$$Z_{0,j} = 0$$

$$Z_{ij} = \left[ \frac{\sum_{m=1}^i RM_m \cdot N_{mj}}{\sum_{m=1}^I RM_m \cdot N_{mj}} \cdot N_{data,j} \right] \text{ for all } i = 1 .. I \quad (1)$$

$$\Delta N_{ij} = Z_{ij} - Z_{i-1,j} - N_{ij} \quad \text{for all } i = 1 .. I$$

#### 4.2.7.2.2.2 Turbo encoded TrCHs

If repetition is to be performed on turbo encoded TrCHs, i.e.  $\Delta N_{il}^{TTI} > 0$ , the parameters in section 4.2.7.2.2.1 are used.

If puncturing is to be performed, the parameters below shall be used. Index  $b$  is used to indicate systematic ( $b=1$ ), 1<sup>st</sup> parity ( $b=2$ ), and 2<sup>nd</sup> parity bit ( $b=3$ ).

$$a=2 \text{ when } b=2$$

$$a=1 \text{ when } b=3$$

The bits indicated by  $b=1$  shall not be punctured.

$$\Delta N_i = \begin{cases} \left\lfloor \Delta N_{il}^{TTI} / 2 \right\rfloor, & b = 2 \\ \left\lfloor \Delta N_{il}^{TTI} / 2 \right\rfloor, & b = 3 \end{cases}$$

For each transmission time interval of TrCH  $i$  with TF  $l$ , the rate-matching pattern is calculated with the algorithm in section 4.2.7.5. The following parameters are used as input:

$$X_i = N_{il}^{TTI} / 3$$

$$e_{ini} = X_i,$$

$$e_{plus} = a \cdot X_i$$

$$e_{minus} = a \cdot |\Delta N_i|$$

#### 4.2.7.3 Bit separation and collection in uplink

The systematic bits (excluding bits for trellis termination) of turbo encoded TrCHs shall not be punctured. The systematic bit, first parity bit, and second parity bit in the bit sequence input to the rate matching block are therefore separated from each other. Puncturing is only applied to the parity bits and systematic bits used for trellis termination.

The bit separation function is transparent for uncoded TrCHs, convolutionally encoded TrCHs, and for turbo encoded TrCHs with repetition. The bit separation and bit collection are illustrated in figures 6 and 7.

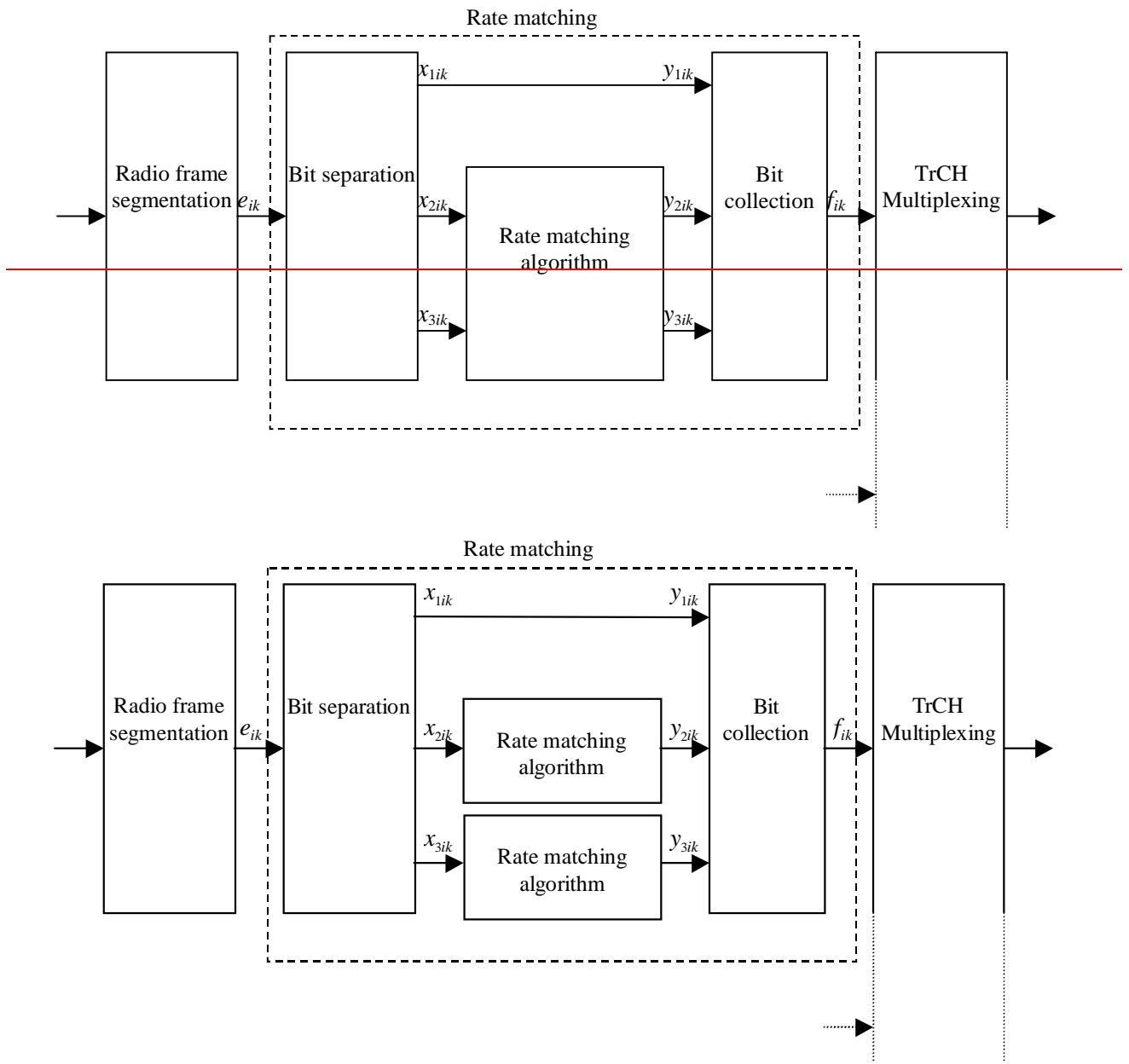
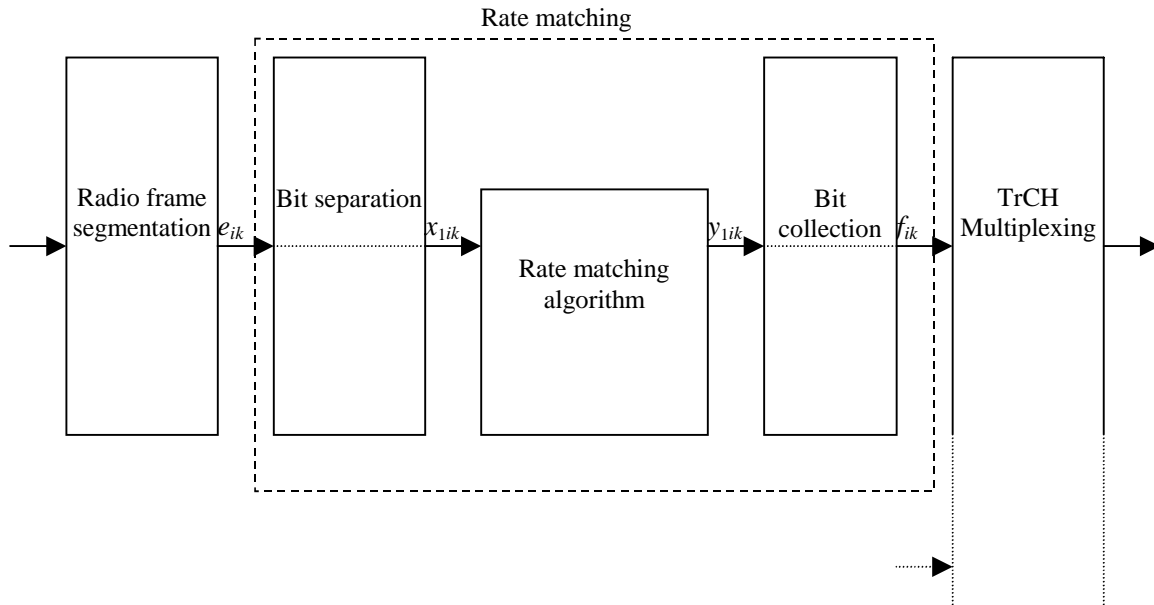

Figure 6: Puncturing of turbo encoded TrCHs in uplink





**Figure 7: Rate matching for uncoded TrCHs, convolutionally encoded TrCHs, and for turbo encoded TrCHs with repetition in uplink.**

The bit separation is dependent on the 1<sup>st</sup> interleaving and offsets are used to define the separation for different TTIs. The offsets  $\alpha_b$ , for the systematic ( $b=1$ ) and parity bits ( $b \in \{2, 3\}$ ) are listed in table 4.

**Table 4: TTI dependent offset needed for bit separation**

TTI (ms)	$\alpha_1$	$\alpha_2$	$\alpha_3$
10, 40	0	1	2
20, 80	0	2	1

The bit separation is different for different radio frames in the TTI. A second offset is therefore needed. The radio frame number for TrCH  $i$  is denoted by  $n_i$ , and the offset by  $\beta_{n_i}$ .

**Table 5: Radio frame dependent offset needed for bit separation**

TTI (ms)	$\beta_0$	$\beta_1$	$\beta_2$	$\beta_3$	$\beta_4$	$\beta_5$	$\beta_6$	$\beta_7$
10	0	NA	NA	NA	NA	NA	NA	NA
20	0	1	NA	NA	NA	NA	NA	NA
40	0	1	2	0	NA	NA	NA	NA
80	0	1	2	0	1	2	0	1

#### 4.2.7.4 Bit separation and collection in downlink

The systematic bits (excluding bits for trellis termination) of turbo encoded TrCHs shall not be punctured. The systematic bit, first parity bit, and second parity bit in the bit sequence input to the rate matching block are therefore separated from each other. Puncturing is only applied to the parity bits and systematic bits used for trellis termination.

The bit separation function is transparent for uncoded TrCHs, convolutionally encoded TrCHs, and for turbo encoded TrCHs with repetition. The bit separation and bit collection are illustrated in figures 8 and 9.

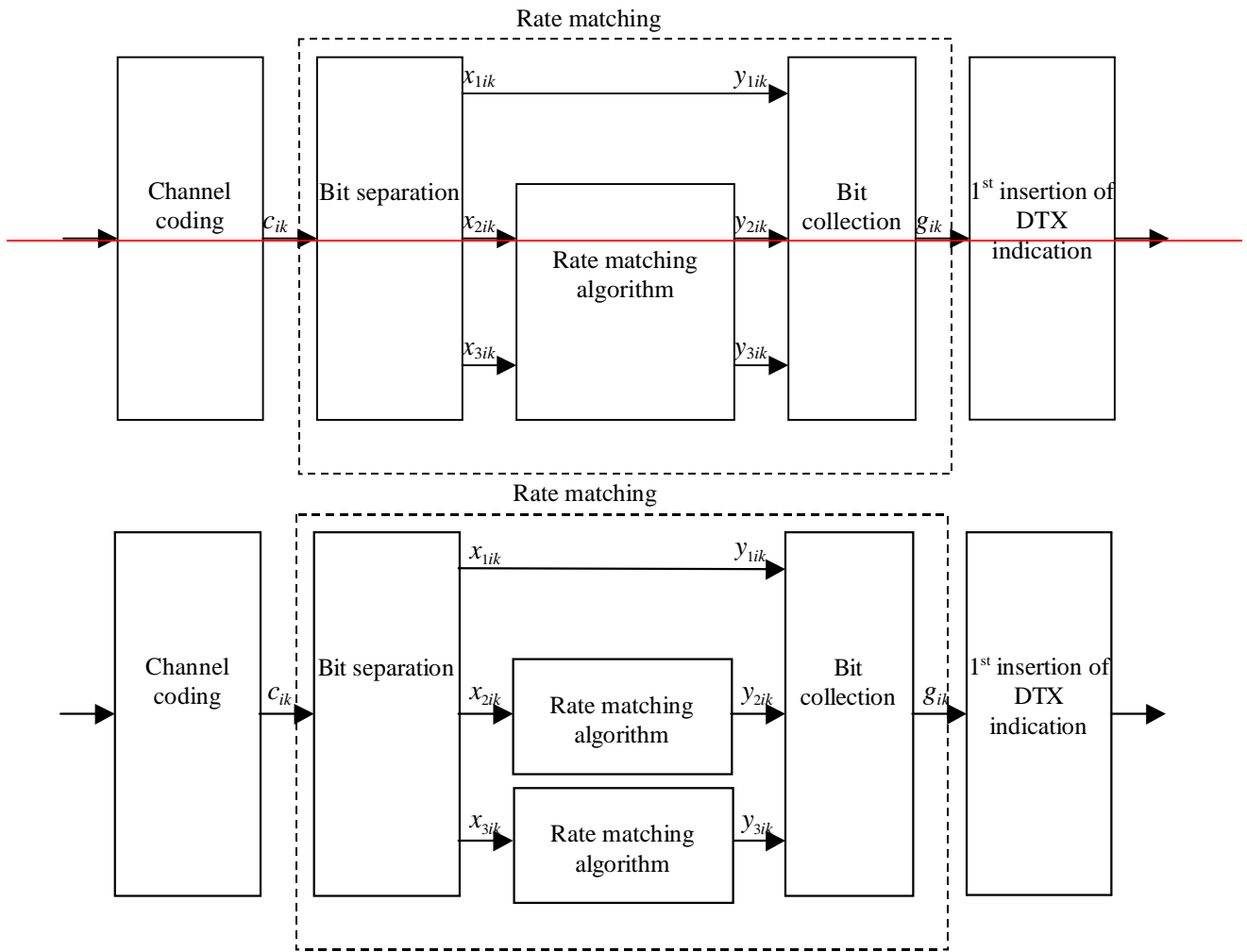

Figure 8: Puncturing of turbo encoded TrCHs in downlink

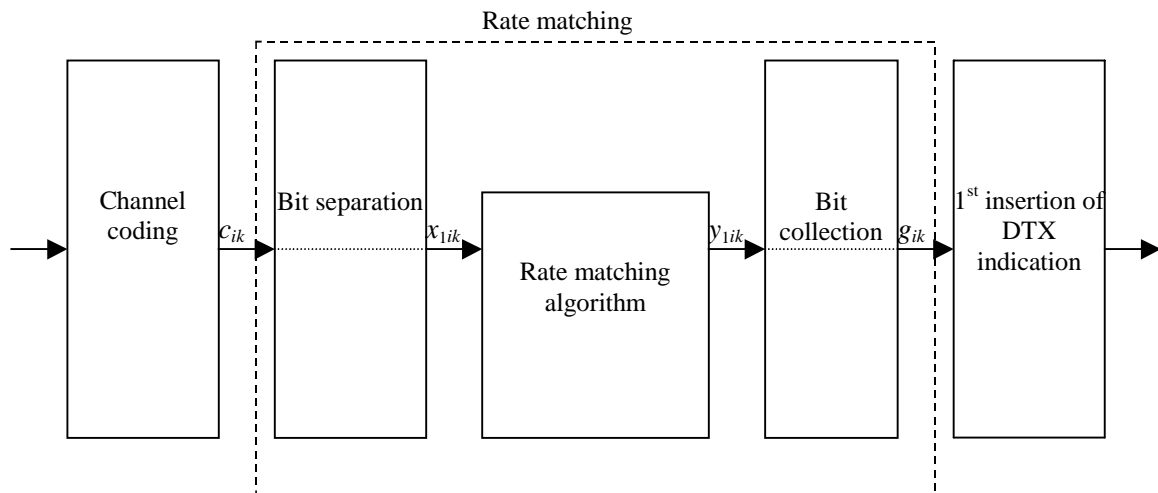

Figure 9: Rate matching for uncoded TrCHs, convolutionally encoded TrCHs, and for turbo encoded TrCHs with repetition in downlink.

#### 4.2.7.5 Rate matching pattern determination

Denote the bits before rate matching by:

$x_{i1}, x_{i2}, x_{i3}, \dots, x_{iX_i}$ , where  $i$  is the TrCH number and the sequence is defined in 4.2.7.3 for uplink or in 4.2.7.4 for downlink. Parameters  $X_i$ ,  $e_{ini}$ ,  $e_{plus}$ , and  $e_{minus}$  is the parameter given in sections 4.2.7.1 and 4.2.7.2 are given in 4.2.7.1 for uplink or in 4.2.7.2 for downlink.

The rate matching rule is as follows:

if puncturing is to be performed

$e = e_{ini}$       -- initial error between current and desired puncturing ratio

$m = 1$       -- index of current bit

do while  $m \leq X_i$

$e = e - e_{minus}$       -- update error

if  $e \leq 0$  then      -- check if bit number  $m$  should be punctured

    set bit  $x_{i,m}$  to  $\delta$  where  $\delta \in \{0, 1\}$

$e = e + e_{plus}$       -- update error

end if

$m = m + 1$       -- next bit

end do

else

$e = e_{ini}$       -- initial error between current and desired puncturing ratio

$m = 1$       -- index of current bit

do while  $m \leq X_i$

$e = e - e_{minus}$       -- update error

do while  $e \leq 0$       -- check if bit number  $m$  should be repeated

    repeat bit  $x_{i,m}$

$e = e + e_{plus}$       -- update error

end do

$m = m + 1$       -- next bit

end do

end if

A repeated bit is placed directly after the original one.

### 4.4.1 Frame structure in the uplink

The frame structure for uplink compressed mode is illustrated in figure 13.

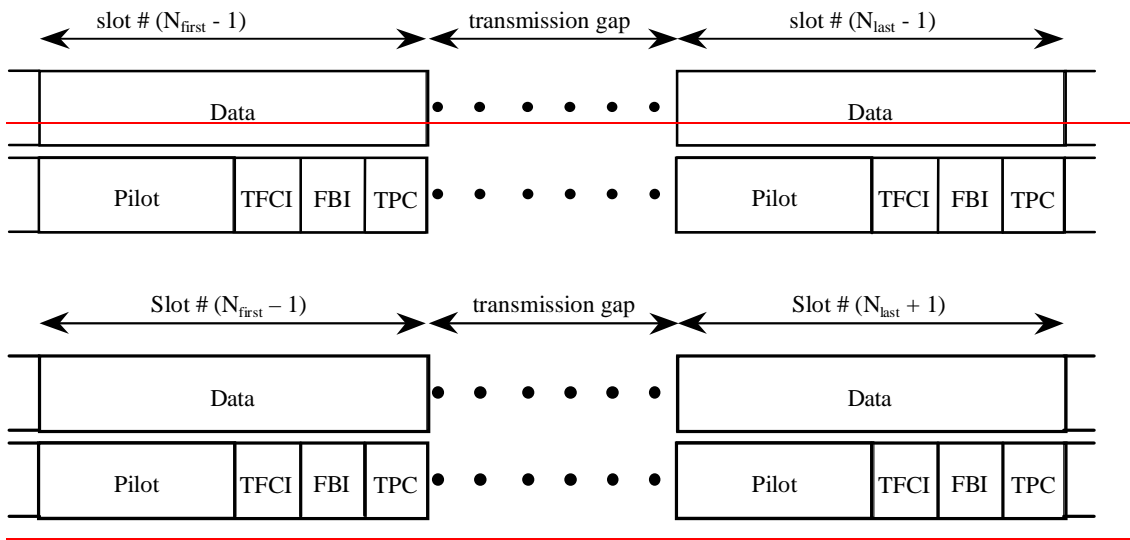

**Figure 13: Frame structure in uplink compressed transmission**



The bits from rate matching are denoted by  $g_{i1}, g_{i2}, g_{i3}, \dots, g_{iG_i}$ , where  $G_i$  is the number of bits in one TTI of TrCH  $i$ . Denote the number of bits in one radio frame of TrCH  $i$  by  $H_i$ . In normal or compressed mode by spreading factor reduction,  $H_i$  is constant and corresponds to the maximum number of bits from TrCH  $i$  in one radio frame for any transport format of TrCH  $i$ . In compressed mode by higher layer scheduling, only a subset of the TFC Set is allowed. From this subset it is possible to derive which TFs on each TrCH that are allowed. The maximum number of bits

belonging to one TTI of TrCH  $i$  for the allowed TFs is denoted by  $X_i$ .  $H_i$  is then calculated as  $H_i = \left\lceil \frac{X_i}{F_i} \right\rceil$ , where  $F_i$  is

the number of radio frames in a TTI of TrCH  $i$ . The bits output from the DTX insertion are denoted by  $h_{i1}, h_{i2}, h_{i3}, \dots, h_{i(F_i H_i)}$ . Note that these bits are three valued. They are defined by the following relations:

$$h_{ik} = g_{ik} \quad k = 1, 2, 3, \dots, G_i$$

$$h_{ik} = \delta \quad k = G_i+1, G_i+2, G_i+3, \dots, F_i H_i$$

where DTX indication bits are denoted by  $\delta$ . Here  $g_{ik} \in \{0, 1\}$  and  $\delta \in \{0, 1\}$ .

#### 4.2.9.2 2<sup>nd</sup> insertion of DTX indication bits

The DTX indication bits inserted in this step shall be placed at the end of the radio frame. Note that the DTX will be distributed over all slots after 2<sup>nd</sup> interleaving.

The bits input to the DTX insertion block are denoted by  $s_1, s_2, s_3, \dots, s_S$ , where  $S$  is the number of bits from TrCH multiplexing. The number of PhCHs is denoted by  $P$  and the number of bits in one radio frame, including DTX

indication bits, for each PhCH by  $U$ . In normal mode  $U = \frac{N_{data,*}}{P} = 15N_{data1} + 15N_{data2}$  ~~The number of available~~

~~bits on the PhCH is denoted by  $N_{data}$  and  $N_{data} = 15N_{data1} + 15N_{data2}$ , where  $N_{data1}$  and  $N_{data2}$  are defined in [25.214]. In normal mode  $U = N_{data}$ .~~ In compressed mode, additional DTX shall be inserted if the transmission time reduction method does not exactly create a transmission gap of the desired TGL. The number of bits available to the CCTrCH in one

radio frame in compressed mode is denoted by  $N_{data,*}^{cm}$  and  $U = \frac{N_{data,*}^{cm}}{P}$ .  ~~$N_{data}$  is changed from the value in normal~~

~~mode. The exact value of  $N_{data,*}^{cm}$  is dependent on the TGL and the transmission time reduction method, which are~~

signalled from higher layers. For transmission time reduction by SF/2 method in compressed mode  $N_{data,*}^{cm} = \frac{N'_{data,*}}{2}$

, and for other methods it can be calculated as  $N_{data,*}^{cm} = N'_{data,*} - N_{TGL}$ . ~~For every transmission time reduction method~~

$N'_{data,*} = P(15N'_{data1} + 15N'_{data2})$ , where  $N'_{data1}$  and  $N'_{data2}$  are the number of bits in the data fields of a slot for slot format A or B as defined in [2].  $N_{TGL}$  is the number of bits that are located within the transmission gap is denoted  $N_{TGL}$  and defined as:

$$N_{TGL} = \begin{cases} \frac{TGL}{15} N'_{data}, & \text{if } N_{first} + TGL \leq 15 \\ \frac{15 - N_{first}}{15} N'_{data}, & \text{in first frame if } N_{first} + TGL > 15 \\ \frac{TGL - (15 - N_{first})}{15} N'_{data}, & \text{in second frame if } N_{first} + TGL > 15 \end{cases}$$

$N_{first}$  and  $TGL$  are defined in Section 4.4.

Note: In compressed mode by SF/2 method DTX is also added in physical channel mapping stage (section 4.2.12.2). During 2<sup>nd</sup> DTX insertion the number of CCTrCH bits is kept the same as in normal mode.

In compressed mode  $U=N_{data} \cdot N_{TGL}$

The bits output from the DTX insertion block are denoted by  $w_1, w_2, w_3, \dots, w_{(PU)}$ . Note that these bits are threevalued. They are defined by the following relations:

$$w_k = s_k \quad k = 1, 2, 3, \dots, S$$

$$w_k = \delta \quad k = S+1, S+2, S+3, \dots, PU$$

where DTX indication bits are denoted by  $\delta$ . Here  $s_k \in \{0,1\}$  and  $\delta \notin \{0,1\}$ .



$$\begin{bmatrix} y_{p1} & y_{p,(R_2+1)} & y_{p,(2R_2+1)} & \cdots & y_{p,(29R_2+1)} \\ y_{p2} & y_{p,(R_2+2)} & y_{p,(2R_2+2)} & \cdots & y_{p,(29R_2+2)} \\ \vdots & \vdots & \vdots & \cdots & \vdots \\ y_{pR_2} & y_{p,(2R_2)} & y_{p,(3R_2)} & \cdots & y_{p,(30R_2)} \end{bmatrix}$$

(5) The output of the 2<sup>nd</sup> interleaving is the bit sequence read out column by column from the inter-column permuted  $R_2 \times C_2$  matrix. The output is pruned by deleting bits that were not present in the input bit sequence, i.e. bits  $y_{pk}$  that corresponds to bits  $u_{pk}$  with  $k > U$  are removed from the output. The bits after 2<sup>nd</sup> interleaving are denoted by  $v_{p1}, v_{p2}, \dots, v_{pU}$ , where  $v_{p1}$  corresponds to the bit  $y_{pk}$  with smallest index  $k$  after pruning,  $v_{p2}$  to the bit  $y_{pk}$  with second smallest index  $k$  after pruning, and so on.

Table 6

Number of column $C_2$	Inter-column permutation pattern
30	{0, 20, 10, 5, 15, 25, 3, 13, 23, 8, 18, 28, 1, 11, 21, 6, 16, 26, 4, 14, 24, 19, 9, 29, 12, 2, 7, 22, 27, 17}

## 4.2.12 Physical channel mapping

The PhCH for both uplink and downlink is defined in [2]. The bits input to the physical channel mapping are denoted by  $v_{p1}, v_{p2}, \dots, v_{pU}$ , where  $p$  is the PhCH number and  $U$  is the number of bits in one radio frame for one PhCH. The bits  $v_{pk}$  are mapped to the PhCHs so that the bits for each PhCH are transmitted over the air in ascending order with respect to  $k$ .

In compressed mode, no bits are mapped to certain slots of the PhCH(s). If  $N_{first} + TGL \leq 15$ , no bits are mapped to slots  $N_{first}$  to  $N_{last}$ . If  $N_{first} + TGL > 15$ , i.e. the transmission gap spans two consecutive radio frames, the mapping is as follows:

- In the first radio frame, no bits are mapped to slots  $N_{first}, N_{first}+1, N_{first}+2, \dots, 14$ .
- In the second radio frame, no bits are mapped to the slots 0, 1, 2, ...,  $N_{last}$ .

$TGL$ ,  $N_{first}$ , and  $N_{last}$  are defined in section 4.4.

### 4.2.12.1 Uplink

In uplink, the PhCHs used during a radio frame are either completely filled with bits that are transmitted over the air or not used at all. The only exception is when the UE is in compressed mode. The transmission can then be turned off during consecutive slots of the radio frame.

### 4.2.12.2 Downlink

In downlink, the PhCHs do not need to be completely filled with bits that are transmitted over the air. Bits  $v_{pk} \notin \{0, 1\}$  are not transmitted.

During compressed mode by reducing the spreading factor by 2, no bits are mapped to the DPDCH field as follows:

If  $N_{first} + TGL \leq 15$ , i.e. the transmission gap spans one radio frame,

if  $N_{first} + 7 \leq 14$

no bits are mapped to slots  $N_{first}, N_{first} + 1, N_{first} + 2, \dots, N_{last} + (7 - TGL)$

no bits are mapped to the first  $(N_{Data1} + N_{Data2})/2$  bit positions of slot  $N_{last} + (8 - TGL)$

else

no bits are mapped to slots  $N_{first}, N_{first} + 1, N_{first} + 2, \dots, 14$

no bits are mapped to slots  $N_{first} - 1, N_{first} - 2, N_{first} - 3, \dots, N_{first} - (7 - TGL - (14 - N_{last}))$

no bits are mapped to the last  $(N_{Data1} + N_{Data2})/2$  bit positions of slot  $N_{first} - (8 - TGL - (14 - N_{last}))$

end if

If  $N_{first} + TGL > 15$ , i.e. the transmission gap spans two consecutive radio frames,

In the first radio frame, no bits are mapped to last  $(N_{Data1} + N_{Data2})/2$  bit positions in slot 7 as well as to slots 8, 9, 10, ..., 14.

In the second radio frame, no bits are mapped to slots 0, 1, 2, ..., 6 as well as to first  $(N_{Data1} + N_{Data2})/2$  bit positions in slot 7.

$N_{Data1}$  and  $N_{Data2}$  are defined in [2].

The following rules should be used for the selection of fixed or flexible positions of the TrCHs in the radio frame:

- For TrCHs not relying on TFCI for transport format detection (blind transport format detection), the positions of the transport channels within the radio frame should be fixed. In a limited number of cases, where there are a small number of transport format combinations, it is possible to allow flexible positions.
- For TrCHs relying on TFCI for transport format detection, higher layer signal whether the positions of the transport channels should be fixed or flexible.



### 4.3.3 Coding of Transport-Format-Combination Indicator (TFCI)

The TFCI bits are encoded using a (32, 10) sub-code of the second order Reed-Muller code. The coding procedure is as shown in figure 10.

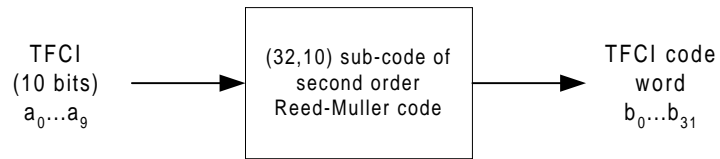

**Figure 10: Channel coding of TFCI bits**

If the TFCI consist of less than 10 bits, it is padded with zeros to 10 bits, by setting the most significant bits to zero. The length of the TFCI code word is 32 bits.

The code words of the (32,10) sub-code of second order Reed-Muller code are linear combination of 10 basis sequences. The basis sequences are as in the following table 7.

**Table 7: Basis sequences for (32,10) TFCI code**

i	M <sub>i,0</sub>	M <sub>i,1</sub>	M <sub>i,2</sub>	M <sub>i,3</sub>	M <sub>i,4</sub>	M <sub>i,5</sub>	M <sub>i,6</sub>	M <sub>i,7</sub>	M <sub>i,8</sub>	M <sub>i,9</sub>
0	14	04	00	00	00	10	0	0	0	0
1	04	10	04	00	00	10	1	0	0	0
2	14	14	04	00	00	10	0	0	0	1
3	04	00	10	04	00	10	1	0	1	1
4	14	04	10	04	00	10	0	0	0	1
5	04	10	14	04	00	10	0	0	1	0
6	14	14	14	04	00	10	0	1	0	0
7	04	00	00	10	04	10	0	1	1	0
8	14	04	00	10	04	10	1	1	1	0
9	04	10	04	10	04	10	1	0	1	1
10	14	14	04	10	04	10	0	0	1	1
11	04	00	10	14	04	10	0	1	1	0
12	14	04	10	14	04	10	0	1	0	1
13	04	10	14	14	04	10	1	0	0	1
14	14	14	14	14	04	10	1	1	1	1
15	14	04	00	00	10	14	1	1	0	0
16	04	10	04	00	10	14	1	1	0	1
17	14	14	04	00	10	14	1	0	1	0
18	04	00	10	04	10	14	0	1	1	1
19	14	04	10	04	10	14	0	1	0	1
20	04	10	14	04	10	14	0	0	1	1
21	14	14	14	04	10	14	0	1	1	1
22	04	00	00	10	14	14	0	1	0	0
23	14	04	00	10	14	14	1	1	0	1
24	04	10	04	10	14	14	1	0	1	0
25	14	14	04	10	14	14	1	0	0	1
26	04	00	10	14	14	14	0	0	1	0
27	14	04	10	14	14	14	1	1	0	0
28	04	10	14	14	14	14	1	1	1	0
29	14	14	14	14	14	14	1	1	1	1
30	04	00	00	00	00	10	0	0	0	0
31	04	00	00	00	10	14	1	0	0	0

For TFCI information bits  $a_0, a_1, a_2, a_3, a_4, a_5, a_6, a_7, a_8, a_9$  ( $a_0$  is LSB and  $a_9$  is MSB), the output code word bits  $b_i$  are given by:

$$b_i = \sum_{n=0}^9 (a_n \times M_{i,n}) \text{ mod } 2$$

where  $i=0\dots31$ .

The output bits are denoted by  $b_k, k = 0, 1, 2, \dots, 31$ .

In downlink, when the SF < 128 the encoded TFCI code words are repeated yielding 8 encoded TFCI bits per slot in normal mode and 16 encoded TFCI bits per slot in compressed mode. Mapping of repeated bits to slots is explained in section 4.3.5.

#### 4.3.4 Operation of Transport-Format-Combination Indicator (TFCI) in Split Mode

In the case of DCH in Split Mode, the UTRAN shall operate with as follows:

- If one of the links is associated with a DSCH, the TFCI code word may be split in such a way that the code word relevant for TFCI activity indication is not transmitted from every cell. The use of such a functionality shall be indicated by higher layer signalling.

The TFCI bits are encoded using a (16, 5) bi-orthogonal (or first order Reed-Muller) code. The coding procedure is as shown in figure 11.

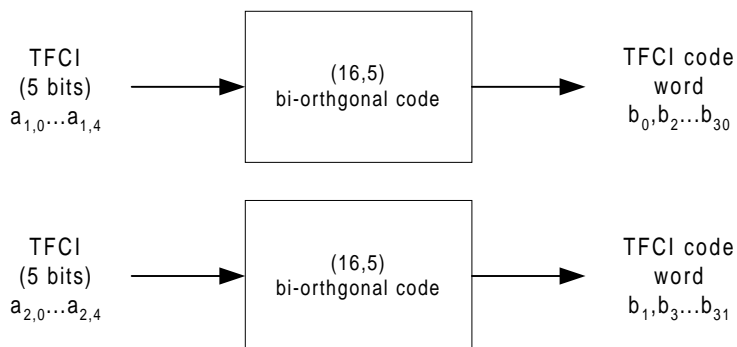

**Figure 11: Channel coding of split mode TFCI bits**

The code words of the (16,5) bi-orthogonal code are linear combinations of 5 basis sequences as defined in table 8 below.

**Table 8: Basis sequences for (16,5) TFCI code**

i	M <sub>i,0</sub>	M <sub>i,1</sub>	M <sub>i,2</sub>	M <sub>i,3</sub>	M <sub>i,4</sub>
0	14	04	00	00	10
1	04	10	04	00	10
2	14	14	04	00	10
3	04	00	10	04	10
4	14	04	10	04	10
5	04	10	14	04	10
6	14	14	14	04	10
7	04	00	00	10	14
8	14	04	00	10	14
9	04	10	04	10	14
10	14	14	04	10	14
11	04	00	10	14	14
12	14	04	10	14	14
13	04	10	14	14	14
14	14	14	14	14	14
15	04	00	00	00	10

For TFCI information bits for DCH  $a_{1,0}, a_{1,1}, a_{1,2}, a_{1,3}, a_{1,4}$  ( $a_{1,0}$  is LSB and  $a_{1,4}$  is MSB) and for DSCH  $a_{2,0}, a_{2,1}, a_{2,2}, a_{2,3}, a_{2,4}$  ( $a_{2,0}$  is LSB and  $a_{2,4}$  is MSB), the output code word bits  $b_0, b_1, \dots, b_{31}$ , are given by:

$$b_{2i} = \sum_{n=0}^4 (a_{1,n} \times M_{i,n}) \text{ mod } 2;$$

$$b_{2i+1} = \sum_{n=0}^4 (a_{2,n} \times M_{i,n}) \text{ mod } 2$$

where  $i=0 \dots 15, j=0,1$ .

The output bits are denoted by  $b_k, k = 0, 1, 2, \dots, 31$ .

<b>CHANGE REQUEST</b>		Please see embedded help file at the bottom of this page for instructions on how to fill in this form correctly.
<b>25.212</b>	<b>CR</b>	<b>048</b>
GSM (AA.BB) or 3G (AA.BBB) specification number ↑		↑ CR number as allocated by MCC support team
For submission to: <b>RAN#7</b>	for approval <input checked="" type="checkbox"/>	Current Version: <b>3.1.1</b>
list expected approval meeting # here ↑	for information <input type="checkbox"/>	strategic <input type="checkbox"/>
		non-strategic <input type="checkbox"/> (for SMG use only)

Form: CR cover sheet, version 2 for 3GPP and SMG The latest version of this form is available from: ftp://ftp.3gpp.org/Information/CR-Form-v2.doc

**Proposed change affects:** (U)SIM  ME  UTRAN / Radio  Core Network   
 (at least one should be marked with an X)

**Source:** TSG RAN WG1 **Date:** 2000-02-21

**Subject:** Mapping of TFCl in downlink compressed mode

**Work item:**

**Category:** F Correction  **Release:** Phase 2   
 A Corresponds to a correction in an earlier release  Release 96   
 B Addition of feature  Release 97   
 C Functional modification of feature  Release 98   
 D Editorial modification  Release 99   
 Release 00   
*(only one category shall be marked with an X)*

**Reason for change:** Comment noting that case of transmission gap split between two frames was not adequately specified by existing text. The existing formulae did not give correct results when  $N_{first}$  occurred in the frame previous to the calculation.

**Clauses affected:** 4.3.5.2.2

**Other specs affected:**

Other 3G core specifications	<input type="checkbox"/>	→ List of CRs:	
Other GSM core specifications	<input type="checkbox"/>	→ List of CRs:	
MS test specifications	<input type="checkbox"/>	→ List of CRs:	
BSS test specifications	<input type="checkbox"/>	→ List of CRs:	
O&M specifications	<input type="checkbox"/>	→ List of CRs:	

**Other comments:**



help.doc

<----- double-click here for help and instructions on how to create a CR.

#### 4.3.5.2.2 Downlink compressed mode

For downlink compressed mode, the slot format is changed so that no TFCI bits are lost. The different slot formats in compressed mode do not match the exact number of TFCI bits for all possible TGLs. DTX is therefore used if the number of TFCI fields exceeds the number of TFCI bits. The block of fields, where DTX is used, starts on the first field after the gap. If there are fewer TFCI fields after the gap than DTX bits, the last fields before of the gap are also filled with DTX.

Denote the number of bits available in the TFCI fields of one compressed radio frame by  $D$  and the number of bits in the TFCI field in a slot by  $N_{TFCI}$ . Denote by  $E$  the first bit to be repeated,  $E = N_{first} N_{TFCI}$ .

$$E = N_{first} N_{TFCI}, \text{ if } N_{first} + TGL \leq 15, \text{ else } E = 0$$

If the transmission gap does not extend to the end of the frame  $N_{last} \neq 14$ , then  $E$  corresponds to the number of the first TFCI bit in the slot directly after the TG. Denote the total number of TFCI bits to be transmitted by  $N_{tot}$ . If SF  $\geq 128$  then  $N_{tot} = 32$ , else  $N_{tot} = 128$ . The following relations then define the mapping:

$$d_k = b_{(k \bmod 32)}$$

where  $k = 0, 1, 2, \dots, \min(E, N_{tot}) - 1$  and, if  $E < N_{tot}$ ,

$$d_{k+D-N_{tot}} = b_{(k \bmod 32)}$$

where  $k = E, \dots, N_{tot} - 1$ .

DTX bits are sent on  $d_k$  where  $k = \min(E, N_{tot}), \dots, \min(E, N_{tot}) + D - N_{tot} - 1$ .





## Annex A (informative): Blind transport format detection

### A.1 Blind transport format detection using fixed positions

#### A.1.1 Blind transport format detection using received power ratio

~~This method is used for the~~ dual transport format case (the possible data rates ~~are~~ 0 and full rate, and ~~only transmitting~~ CRC ~~is only transmitted~~ for full rate), blind transport format detection using received power ratio can be used.

The ~~transport format rate~~ detection is then done using average received power ratio of DPDCH to DPCCH. Define the following:

- $P_c$ : Received ~~p~~Power per bit of DPCCH calculated from all pilot and TPC bits per slot over a radio~~10ms~~ frame.
- $P_d$ : Received ~~p~~Power per bit of DPDCH calculated from  $X$  bits per slot over a radio~~10ms~~ frame.
- $X$ : the number of DPDCH bits per slot when transport format corresponds to full rate.
- $T$ : Threshold of average received power ratio of DPDCH to DPCCH for transport format rate detection.

The decision rule can then be formulated as

If  $P_d/P_c > T$  then

Full rate transport format detected."TX\_ON"

else

Zero rate transport format detected."TX\_OFF"

#### A.1.2 Blind transport format detection using CRC

~~— This method is used for the~~ multiple transport format case (the possible data rates ~~are~~ 0, ..., (full rate)/ $r$ , ..., full rate, and ~~always transmitting~~ CRC ~~is transmitted~~ for all transport formats), blind transport format detection using CRC can be used. ~~When this method is used, no one transport format should have the same number of bits as any other transport format does within a TrCH.~~

~~—~~At the transmitter, the data stream with variable number of bits from higher layers is block-encoded using a cyclic redundancy check (CRC) and then convolutionally encoded. ~~-~~CRC parity bits are attached just after the data stream with variable number of bits as shown in figure A-1.

~~—~~The receiver knows only the possible transport formats (or the possible end bit position  $\{n_{end}\}$ ) by Layer-3 negotiation ~~(see figure A-1)~~. ~~-~~The receiver performs Viterbi-decoding ~~-~~on the soft decision sample sequence. ~~-~~The correct trellis path of the Viterbi-decoder ~~-~~ends at the zero state at the correct end bit position.

~~—~~The ~~B~~blind transport format rate detection method ~~by~~ using CRC traces back the surviving trellis path ending at the zero state (hypothetical trellis path) at each possible end bit position to recover the data sequence. ~~-~~For ~~E~~each recovered data sequence ~~is then~~ error-detection is performed by checking the ~~by~~ CRC, and if there is no error, the recovered sequence is declared to be correct.

~~—~~The following variable is defined:

$$s(n_{end}) = -10 \log \left( \frac{a_0(n_{end}) - a_{min}(n_{end})}{a_{max}(n_{end}) - a_{min}(n_{end})} \right) \text{ [dB]} \quad (\text{Eq. 1})$$

~~—~~where  $a_{max}(n_{end})$  and  $a_{min}(n_{end})$  are, respectively, the maximum and minimum path-metric values among all survivors at end bit position  $n_{end}$ , and  $a_0(n_{end})$  is the path-metric value at zero state.

—In order to reduce the probability of false detection (this happens if the selected path is wrong but the CRC misses the error detection), a path selection threshold  $D$  is introduced. —The threshold  $D$  determines whether the hypothetical trellis path connected to the zero state should be traced back or not at each end bit position  $n_{end}$ . —If the hypothetical trellis path connected to the zero state that satisfies

$$s(n_{end}) \leq D \text{ (Eq. 2)}$$

—is found, the path is traced back to recover the frame data, where  $D$  is the path selection threshold and a design parameter.

—If more than one end bit positions satisfying Eq. 2 ~~is are~~ found, the end bit position which has minimum value of  $s(n_{end})$  is declared to be correct.

—If no path satisfying Eq. 2 is found even after all possible end bit positions have been exhausted, the received frame data is declared to be in error.

Figure A-2 shows the procedure of blind transport format detection using CRC.

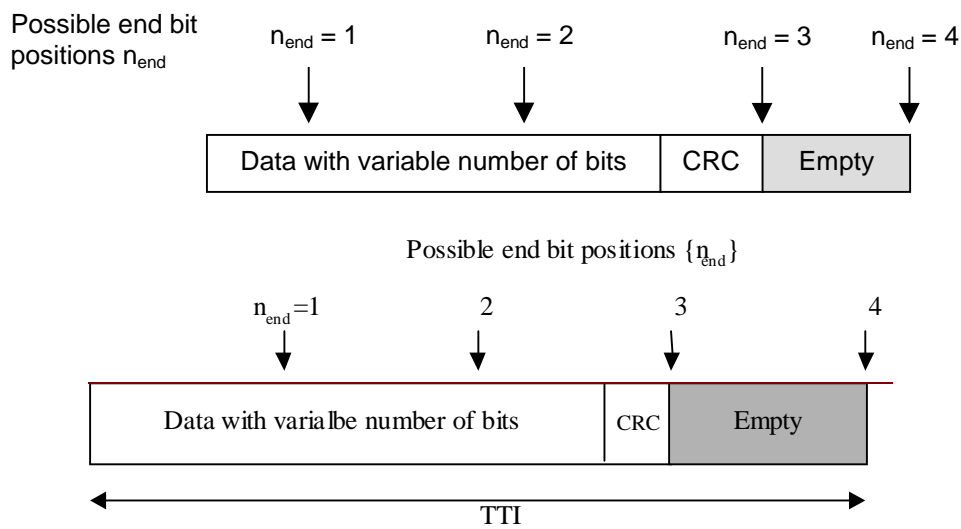

**Figure A-1: An example of ~~the data format with variable number of bits. Four possible transport formats, and transmitted end bit position  $n_{end} = 3$ .~~**

~~(Number of possible transport formats = 4, transmitted end bit position  $n_{end} = 3$ )~~

## A.2 Blind transport format detection with flexible positions

In certain cases where the CC<sub>TrCH</sub> consists of multiple transport channels and a small number of transport format combinations are allowed, it is possible to allow blind transport format detection with flexible positions.

Several examples for how the blind transport format detection with flexible positions might be performed are:

- The blind transport format detection starts at a fixed position and identifies the transport format of the first present transport channel and stops. The position of the other transport channels and their transport format being derived on the basis of the allowed transport format combinations, assuming that there is a one to one relationship between the transport format combination and the transport format of the first present transport channel.
- The blind rate detection evaluates all transport format combinations and picks the most reliable one.

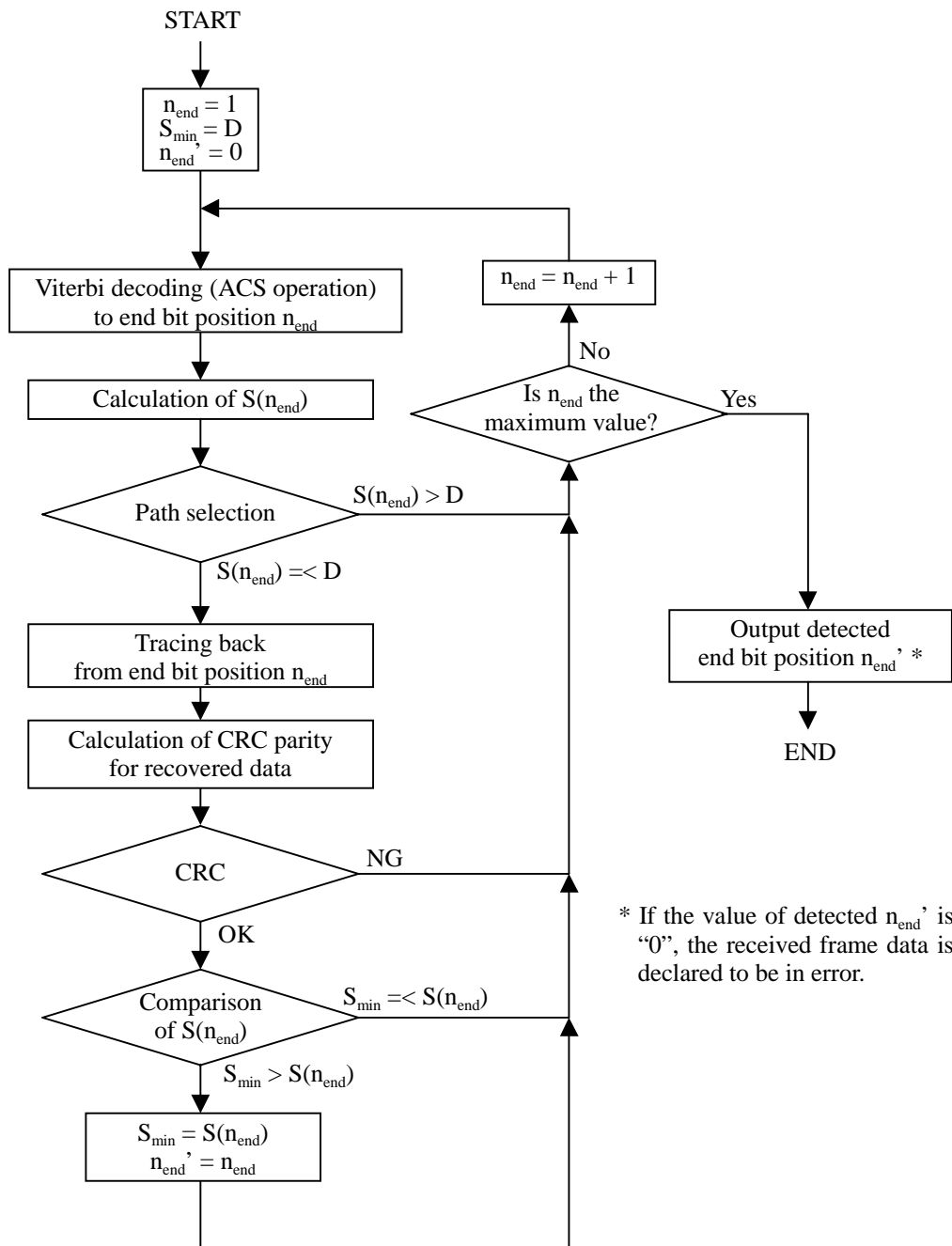

Figure A-2: Basic processing flow of blind transport format detection.



## 4.2.13 Restrictions on different types of CCTrCHs

Restrictions on the different types of CCTrCHs are described in general terms in TS 25.302[11]. In this section those restrictions are given with layer 1 notation.

### 4.2.13.1 Uplink Dedicated channel (DCH)

The maximum value of the number of TrCHs  $I$  in a CCTrCH, the maximum value of the number of transport blocks  $M_i$  on each transport channel, and the maximum value of the number of DPDCHs  $P$  are given from the UE capability class.

### 4.2.13.2 Random Access Channel (RACH)

- There can only be one TrCH in each RACH CCTrCH, i.e.  $I=1$ ,  $s_k = f_{1k}$  and  $S = V_1$ .
- The maximum value of the number of transport blocks  $M_1$  on the transport channel is given from the UE capability class.
- The transmission time interval is either 10 ms or 20 ms.

~~At initial RACH transmission the rate matching attribute has a predefined value.~~

- Only one PRACH is used, i.e.  $P=1$ ,  $u_{1k} = s_k$ , and  $U = S$ .

### 4.2.13.3 Common Packet Channel (CPCH)

- The maximum value of the number of TrCHs  $I$  in a CCTrCH, the maximum value of the number of transport blocks  $M_i$  on each transport channel, and the maximum value of the number of DPDCHs  $P$  are given from the UE capability class.

NOTE: Only the data part of the CPCH can be mapped on multiple physical channels (this note is taken from TS 25.302).

### 4.2.13.4 Downlink Dedicated Channel (DCH)

The maximum value of the number of TrCHs  $I$  in a CCTrCH, the maximum value of the number of transport blocks  $M_i$  on each transport channel, and the maximum value of the number of DPDCHs  $P$  are given from the UE capability class.

### 4.2.13.5 Downlink Shared Channel (DSCH) associated with a DCH

- The spreading factor is indicated with the TFCI or with higher layer signalling on DCH.
- The maximum value of the number of transport blocks  $M_1$  on the transport channel and the maximum value of the number of PDSCHs  $P$  are given from the UE capability class.

### 4.2.13.6 Broadcast channel (BCH)

- There can only be one TrCH in the BCH CCTrCH, i.e.  $I=1$ ,  $s_k = f_{1k}$ , and  $S = V_1$ .
- There can only be one transport block in each transmission time interval, i.e.  $M_1 = 1$ .
- All transport format attributes have predefined values.
- Only one primary CCPCH is used, i.e.  $P=1$ .

### 4.2.13.7 Forward access and paging channels (FACH and PCH)

- The maximum value of the number of TrCHs  $I$  in a CCTrCH and the maximum value of the number of transport blocks  $M_i$  on each transport channel are given from the UE capability class.
- The transmission time interval for TrCHs of PCH type is always 10 ms.

- Only one secondary CCPCH is used per CCTrCH, i.e.  $P=1$ .

<b>CHANGE REQUEST</b>		Please see embedded help file at the bottom of this page for instructions on how to fill in this form correctly.
<b>25.212</b>	<b>CR 052</b>	Current Version: <b>3.1.1</b>
GSM (AA.BB) or 3G (AA.BBB) specification number ↑	↑ CR number as allocated by MCC support team	
For submission to: <b>WG1 #11</b> <small>list expected approval meeting # here ↑</small>	for approval <input checked="" type="checkbox"/> for information <input type="checkbox"/>	strategic <input type="checkbox"/> non-strategic <input type="checkbox"/> <small>(for SMG use only)</small>

Form: CR cover sheet, version 2 for 3GPP and SMG    The latest version of this form is available from: <ftp://ftp.3gpp.org/Information/CR-Form-v2.doc>

**Proposed change affects:**    (U)SIM     ME     UTRAN / Radio     Core Network   
(at least one should be marked with an X)

**Source:**    TSG RAN WG1    **Date:**    29.02.2000

**Subject:**    Padding Function for Turbo coding of small blocks

**Work item:**    TS 25.212

<b>Category:</b>	F Correction <input type="checkbox"/> A Corresponds to a correction in an earlier release <input type="checkbox"/> B Addition of feature <input checked="" type="checkbox"/> C Functional modification of feature <input type="checkbox"/> D Editorial modification <input type="checkbox"/>	<b>Release:</b>	Phase 2 <input type="checkbox"/> Release 96 <input type="checkbox"/> Release 97 <input type="checkbox"/> Release 98 <input type="checkbox"/> Release 99 <input checked="" type="checkbox"/> Release 00 <input type="checkbox"/>
------------------	--	-----------------	--

(only one category shall be marked with an X)

**Reason for change:**    At the last meeting #10 the smallest block size for Turbo coding was set to 40. It was left over to include a functionality to handle blocks of smaller size than 40 bits. This is added in the specification by this CR.

**Clauses affected:**    4.2.2.2 Code block segmentation

<b>Other specs affected:</b>	Other 3G core specifications <input type="checkbox"/> Other GSM core specifications <input type="checkbox"/> MS test specifications <input type="checkbox"/> BSS test specifications <input type="checkbox"/> O&M specifications <input type="checkbox"/>	→ List of CRs: → List of CRs: → List of CRs: → List of CRs: → List of CRs:	
------------------------------	---	--	--

**Other comments:**    The corresponding CR for TDD mode is 25.222-026.



## 4.2.2 Transport block concatenation and code block segmentation

All transport blocks in a TTI are serially concatenated. If the number of bits in a TTI is larger than  $Z$ , the maximum size of a code block in question, then code block segmentation is performed after the concatenation of the transport blocks. The maximum size of the code blocks depends on whether convolutional coding, turbo coding or no coding is used for the TrCH.

### 4.2.2.1 Concatenation of transport blocks

The bits input to the transport block concatenation are denoted by  $b_{im1}, b_{im2}, b_{im3}, \dots, b_{imB_i}$  where  $i$  is the TrCH number,  $m$  is the transport block number, and  $B_i$  is the number of bits in each block (including CRC). The number of transport blocks on TrCH  $i$  is denoted by  $M_i$ . The bits after concatenation are denoted by  $x_{i1}, x_{i2}, x_{i3}, \dots, x_{iX_i}$ , where  $i$  is the TrCH number and  $X_i = M_i B_i$ . They are defined by the following relations:

$$x_{ik} = b_{i1k} \quad k = 1, 2, \dots, B_i$$

$$x_{ik} = b_{i,2,(k-B_i)} \quad k = B_i + 1, B_i + 2, \dots, 2B_i$$

$$x_{ik} = b_{i,3,(k-2B_i)} \quad k = 2B_i + 1, 2B_i + 2, \dots, 3B_i$$

...

$$x_{ik} = b_{i,M_i,(k-(M_i-1)B_i)} \quad k = (M_i - 1)B_i + 1, (M_i - 1)B_i + 2, \dots, M_i B_i$$

### 4.2.2.2 Code block segmentation

Segmentation of the bit sequence from transport block concatenation is performed if  $X_i > Z$ . The code blocks after segmentation are of the same size. The number of code blocks on TrCH  $i$  is denoted by  $C_i$ . If the number of bits input to the segmentation,  $X_i$ , is not a multiple of  $C_i$ , filler bits are added to the beginning of the first last block. The filler bits are transmitted and they are always set to 0. The maximum code block sizes are:

convolutional coding:  $Z = 504$

turbo coding:  $Z = 5114$

no channel coding:  $Z = unlimited$

The bits output from code block segmentation are denoted by  $o_{ir1}, o_{ir2}, o_{ir3}, \dots, o_{irK_i}$ , where  $i$  is the TrCH number,  $r$  is the code block number, and  $K_i$  is the number of bits.

$$\text{Number of code blocks: } C_i = \lceil X_i / Z \rceil$$

Number of bits in each code block:

if  $X_i < 40$  and Turbo coding is used, then

$$\underline{K_i = 40}$$

else

$$\underline{K_i = \lceil X_i / C_i \rceil}$$

end if

$$\text{Number of filler bits: } Y_i = C_i K_i - X_i$$

If  $X_i \leq Z$ , then

$$\underline{o_{ik} = 0} \quad k = 1, 2, \dots, Y_i$$

$$O_{i1k} = x_{i,(k-Y_i)} \quad \cancel{O_{i1k} = x_{ik}} \quad k = Y_i+1, Y_i+2, \dots, K_i$$

end if

~~, and  $K_i = X_i$ .~~

If  $X_i \geq Z$ , then

$$O_{i1k} = 0 \quad k = 1, 2, \dots, Y_i$$

$$O_{i1k} = x_{i,(k-Y_i)} \quad \cancel{O_{i1k} = x_{ik}} \quad k = Y_i+1, Y_i+2, \dots, K_i$$

$$O_{i2k} = x_{i,(k+K_i-Y_i)} \quad \cancel{O_{i2k} = x_{i,(k+K_i)}} \quad k = 1, 2, \dots, K_i$$

$$O_{i3k} = x_{i,(k+2K_i-Y_i)} \quad \cancel{O_{i3k} = x_{i,(k+2K_i)}} \quad k = 1, 2, \dots, K_i$$

...

$$O_{iC_k} = x_{i,(k+(C_i-1)K_i-Y_i)} \quad \cancel{O_{iC_k} = x_{i,(k+(C_i-1)K_i)}} \quad k = 1, 2, \dots, K_i - Y_i$$

$$\cancel{O_{iC_k} = 0 \quad k = (K_i - Y_i) + 1, (K_i - Y_i) + 2, \dots, K_i}$$

end if



<b>CHANGE REQUEST</b>		Please see embedded help file at the bottom of this page for instructions on how to fill in this form correctly.		
<b>25.212</b>	<b>CR</b>	<b>055r2</b>		
GSM (AA.BB) or 3G (AA.BBB) specification number ↑		↑ CR number as allocated by MCC support team		
Current Version: <b>3.1.1</b>				
For submission to: <b>RAN#7</b> <small>list expected approval meeting # here ↑</small>	for approval for information	<table border="1" style="margin-left: auto; margin-right: auto;"> <tr><td style="text-align: center;"><b>X</b></td></tr> <tr><td style="text-align: center;"> </td></tr> </table>	<b>X</b>	
<b>X</b>				
		strategic <input type="checkbox"/> non-strategic <input type="checkbox"/> <small>(for SMG use only)</small>		

Form: CR cover sheet, version 2 for 3GPP and SMG    The latest version of this form is available from: <ftp://ftp.3gpp.org/Information/CR-Form-v2.doc>

**Proposed change affects:**    (U)SIM     ME     UTRAN / Radio     Core Network   
(at least one should be marked with an X)

**Source:**    TSG RAN WG1    **Date:**    28/02/2000

**Subject:**    Clarifications relating to DSCH

**Work item:**    \_\_\_\_\_

<b>Category:</b>	F Correction <input checked="" type="checkbox"/> A Corresponds to a correction in an earlier release <input type="checkbox"/> B Addition of feature <input type="checkbox"/> C Functional modification of feature <input type="checkbox"/> D Editorial modification <input type="checkbox"/>	<b>Release:</b>	Phase 2 <input type="checkbox"/> Release 96 <input type="checkbox"/> Release 97 <input type="checkbox"/> Release 98 <input type="checkbox"/> Release 99 <input checked="" type="checkbox"/> Release 00 <input type="checkbox"/>
------------------	--	-----------------	--

(only one category shall be marked With an X)

**Reason for change:**    A number of changes are made to the downlink shared channel description in order to clarify the following points:

1. The CCTrCH of type DSCH may multiplex more than one DSCH. This change brings the specification in line with 25.302.
2. A maximum of one CCTrCH of type DSCH is allowed for one UE.
3. Blind transport format detection in the downlink can not be used with a DSCH.
4. Furthermore, the CR proposes to resolve an FFS (chapter 4.2.14.1.2) relating to the allowed combination of CCTrCHs of dedicated and common type

**Clauses affected:**    4.2.13.5, 4.2.14.1.2, 4.3

<b>Other specs Affected:</b>	Other 3G core specifications <input type="checkbox"/> Other GSM core specifications <input type="checkbox"/> MS test specifications <input type="checkbox"/> BSS test specifications <input type="checkbox"/> O&M specifications <input type="checkbox"/>	→ List of CRs: _____ → List of CRs: _____ → List of CRs: _____ → List of CRs: _____ → List of CRs: _____
------------------------------	---	--

**Other comments:**    \_\_\_\_\_

<----- double-click here for help and instructions on how to create a CR.

## 4.2.13 Restrictions on different types of CCTrCHs

Restrictions on the different types of CCTrCHs are described in general terms in TS 25.302[11]. In this section those restrictions are given with layer 1 notation.

### 4.2.13.1 Uplink Dedicated channel (DCH)

The maximum value of the number of TrCHs  $I$  in a CCTrCH, the maximum value of the number of transport blocks  $M_i$  on each transport channel, and the maximum value of the number of DPDCHs  $P$  are given from the UE capability class.

### 4.2.13.2 Random Access Channel (RACH)

- There can only be one TrCH in each RACH CCTrCH, i.e.  $I=1$ ,  $s_k = f_{1k}$  and  $S = V_1$ .
- The maximum value of the number of transport blocks  $M_1$  on the transport channel is given from the UE capability class.
- The transmission time interval is either 10 ms or 20 ms.
- At initial RACH transmission the rate matching attribute has a predefined value.
- Only one PRACH is used, i.e.  $P=1$ ,  $u_{1k} = s_k$ , and  $U = S$ .

### 4.2.13.3 Common Packet Channel (CPCH)

- The maximum value of the number of TrCHs  $I$  in a CCTrCH, the maximum value of the number of transport blocks  $M_i$  on each transport channel, and the maximum value of the number of DPDCHs  $P$  are given from the UE capability class.

NOTE: Only the data part of the CPCH can be mapped on multiple physical channels (this note is taken from TS 25.302).

### 4.2.13.4 Downlink Dedicated Channel (DCH)

The maximum value of the number of TrCHs  $I$  in a CCTrCH, the maximum value of the number of transport blocks  $M_i$  on each transport channel, and the maximum value of the number of DPDCHs  $P$  are given from the UE capability class.

### 4.2.13.5 Downlink Shared Channel (DSCH) associated with a DCH

- The spreading factor is indicated with the TFCI or with higher layer signalling on DCH.
- The maximum value of the number of TrCHs  $I$  in a CCTrCH, the maximum value of the number of transport blocks  $M_i$  on the transport channel and the maximum value of the number of PDSCHs  $P$  are given from the UE capability class.

### 4.2.13.6 Broadcast channel (BCH)

- There can only be one TrCH in the BCH CCTrCH, i.e.  $I=1$ ,  $s_k = f_{1k}$ , and  $S = V_1$ .
- There can only be one transport block in each transmission time interval, i.e.  $M_1 = 1$ .
- All transport format attributes have predefined values.
- Only one primary CCPCH is used, i.e.  $P=1$ .

#### 4.2.13.7 Forward access and paging channels (FACH and PCH)

- The maximum value of the number of TrCHs  $I$  in a CCTrCH and the maximum value of the number of transport blocks  $M_i$  on each transport channel are given from the UE capability class.
- The transmission time interval for TrCHs of PCH type is always 10 ms.
- Only one secondary CCPCH is used per CCTrCH, i.e.  $P=1$ .

#### 4.2.14 Multiplexing of different transport channels into one CCTrCH, and mapping of one CCTrCH onto physical channels

The following rules shall apply to the different transport channels which are part of the same CCTrCH:

- 1) Transport channels multiplexed into one CCTrCh shall have co-ordinated timings. When the TFCS of a CCTrCH is changed because a transport channel  $i$  is added to the CCTrCH or reconfigured within the CCTrCH, the TTI of transport channel  $i$  may only start in radio frames with CFN fulfilling the relation

$$CFN_i \bmod F_{\max} = 0,$$

where  $F_{\max}$  denotes the maximum number of radio frames within the transmission time intervals of all transport channels which are multiplexed into the same CCTrCH, including transport channel  $i$  which is added or reconfigured, and  $CFN_i$  denotes the connection frame number of the first radio frame within the transmission time interval of transport channel  $i$ .

After addition or reconfiguration of a transport channel  $i$  within a CCTrCH, the TTI of transport channel  $i$  may only start in radio frames with CFN fulfilling the relation

$$CFN_i \bmod F_i = 0.$$

- 2) Only transport channels with the same active set can be mapped onto the same CCTrCH.
- 3) Different CCTrCHs cannot be mapped onto the same PhCH.
- 4) One CCTrCH shall be mapped onto one or several PhCHs. These physical channels shall all have the same SF.
- 5) Dedicated Transport channels and common transport channels cannot be multiplexed into the same CCTrCH
- 6) For the common transport channels, only the FACH and PCH may belong to the same CCTrCH

There are hence two types of CCTrCH

- 1) CCTrCH of dedicated type, corresponding to the result of coding and multiplexing of one or several DCHs.
- 2) CCTrCH of common type, corresponding to the result of the coding and multiplexing of a common channel, RACH in the uplink, DSCH, BCH, or FACH/PCH for the downlink.

##### 4.2.14.1 Allowed CCTrCH combinations for one UE

###### 4.2.14.1.1 Allowed CCTrCH combinations on the uplink

A maximum of one CCTrCH is allowed for one UE on the uplink. It can be either

- 1) one CCTrCH of dedicated type
- 2) one CCTrCH of common type

#### 4.2.14.1.2 Allowed CcTrCH combinations on the downlink

The following CcTrCH combinations for one UE are allowed :

x CcTrCH of dedicated type + y CcTrCH of common type

The allowed combination of CcTrCHs of dedicated and common type are FFS-given from UE radio access capabilities. There can be a maximum on one CcTrCH of common type for DSCH and a maximum of one CcTrCH of common type for FACH. With one CcTrCH of common type for DSCH, there shall be at least one CcTrCH of dedicated type

NOTE 1: There is only one DPCCH in the uplink, hence one TPC bits flow on the uplink to control possibly the different DPDCHs on the downlink, part of the same or several CcTrCHs.

NOTE 2: There is only one DPCCH in the downlink, even with multiple CcTrCHs. With multiple CcTrCHs, the DPCCH is transmitted on one of the physical channels of that CcTrCH which has the smallest SF among the multiple CcTrCHs. Thus there is only one TPC command flow and only one TFCI word in downlink even with multiple CcTrCHs.

### 4.3 Transport format detection

Transport format detection can be performed both with and without Transport Format Combination Indicator (TFCI). If a TFCI is transmitted, the receiver detects the transport format combination from the TFCI. When no TFCI is transmitted, so called blind transport format detection may be used, i.e. the receiver side detects the transport format combination using some information, e.g. received power ratio of DPDCH to DPCCH, CRC check results.

For uplink, the blind transport format detection is an operator option. For downlink, the blind transport format detection can be applied with convolutional coding, the maximum number of different transport formats and maximum data rates allowed shall be specified.

When a DSCH is associated with a DCH, then the DPCCH shall include TFCI.

For a DPCH associated with a PDSCH, the DPCCH shall include TFCI.

#### 4.3.1 Blind transport format detection

Examples of blind transport format detection methods are given in Annex A.

#### 4.3.2 Explicit transport format detection based on TFCI

The Transport Format Combination Indicator (TFCI) informs the receiver of the transport format combination of the CcTrCHs. As soon as the TFCI is detected, the transport format combination, and hence the individual transport channels' transport formats are known, and decoding of the transport channels can be performed.

#### 4.3.3 Coding of Transport-Format-Combination Indicator (TFCI)

The TFCI bits are encoded using a (32, 10) sub-code of the second order Reed-Muller code. The coding procedure is as shown in figure 10.

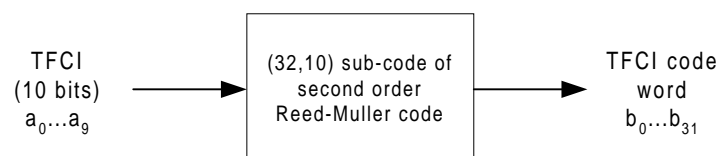

Figure 10: Channel coding of TFCI bits

If the TFCI consist of less than 10 bits, it is padded with zeros to 10 bits, by setting the most significant bits to zero. The length of the TFCI code word is 32 bits.

The code words of the (32,10) sub-code of second order Reed-Muller code are linear combination of 10 basis sequences. The basis sequences are as in the following table 7.





## 4.2.7.1.2.2 Turbo encoded TrCHs

If repetition is to be performed on turbo encoded TrCHs, i.e.  $\Delta N_{i,j} > 0$ , the parameters in section 4.2.7.1.2.1 are used.

If puncturing is to be performed, the parameters below shall be used. Index  $b$  is used to indicate systematic ( $b=1$ ), 1<sup>st</sup> parity ( $b=2$ ), and 2<sup>nd</sup> parity bit ( $b=3$ ).

$a=2$  when  $b=2$

$a=1$  when  $b=3$

$$\Delta N_i = \begin{cases} \lfloor \Delta N_{i,j} / 2 \rfloor, & b = 2 \\ \lfloor \Delta N_{i,j} / 2 \rfloor, & b = 3 \end{cases}$$

If  $\Delta N_i$  is calculated as 0 for  $b=2$  or  $b=3$ , then the following procedure and the rate matching algorithm of section 4.2.7.5 don't need to be performed for the corresponding parity bit stream.

$$X_i = \lfloor N_{i,j} / 3 \rfloor,$$

$$q = \lfloor X_i / |\Delta N_i| \rfloor$$

if( $q \leq 2$ )

for  $x=0$  to  $F_i-1$

$$S[\text{IF}[(3x+b-1) \bmod F_i]] = x \bmod 2;$$

end for

else

if  $q$  is even

then  $q' = q - \text{gcd}(q, F_i) / F_i$  -- where  $\text{gcd}(q, F_i)$  means greatest common divisor of  $q$  and  $F_i$   
-- note that  $q'$  is not an integer, but a multiple of  $1/8$

else  $q' = q$

endif

for  $x=0$  to  $F_i-1$

$$r = \lceil x * q' \rceil \bmod F_i;$$

$$S[\text{IF}[(3r+b-1) \bmod F_i]] = \lceil x * q' \rceil \text{div } F_i;$$

endfor

endif

For each radio frame, the rate-matching pattern is calculated with the algorithm in section 4.2.7.5, where:

$X_i$  is as above,

$$e_{\text{ini}} = (a \cdot S(n_i) \cdot |\Delta N_i| + X_i) \bmod (a \cdot X_i), \text{ if } e_{\text{ini}} = 0 \text{ then } e_{\text{ini}} = a \cdot X_i.$$

$$e_{\text{plus}} = a \cdot X_i$$

$$e_{\text{minus}} = a \cdot |\Delta N_i|$$