

**TSG-RAN Meeting #7
Madrid, Spain, 13 – 15 March 2000**

TSGRP#6(00)0015

Title: Agreed CRs to TS 25.101

Source: TSG-RAN WG4

Agenda item: 6.2.3

Spec	CR	Rev	Phas	Subject	Cat	Current	New	WG4 doc
25.101	020		R99	Clarifications to measurement channels	F	3.1.0	3.2.0	R4-000059
25.101	021		R99	Power measurement definitions for wanted signal (in-channel signal)	D	3.1.0	3.2.0	R4-000103
25.101	022		R99	Change of propagation conditions for Case 2	F	3.1.0	3.2.0	R4-000096
25.101	023		R99	Editorial corrections	D	3.1.0	3.2.0	R4-000191
25.101	024		R99	Birth-Death tap delays	F	3.1.0	3.2.0	R4-000163
25.101	025		R99	Out-of-synchronisation handling of the UE	C	3.1.0	3.2.0	R4-000141
25.101	026		R99	UE Modulation performance requirements	F	3.1.0	3.2.0	R4-000195
25.101	027		R99	Measurement channel for UE PCDE test	F	3.1.0	3.2.0	R4-000281
25.101	028		R99	CR for performance requirement of BTFD	F	3.1.0	3.2.0	R4-000204
25.101	029		R99	CPCH	B	3.1.0	3.2.0	R4-000251
25.101	030		R99	Clarification of ACLR	D	3.1.0	3.2.0	R4-000239
25.101	031		R99	Correction for reference measurement channel in TS 25.101	F	3.1.0	3.2.0	R4-000269
25.101	032		R99	Modifications to requirements for power control steps in uplink	F	3.1.0	3.2.0	R4-000276
25.101	033		R99	Performance requirement	F	3.1.0	3.2.0	R4-000306
25.101	034		R99	Power Control in downlink, constant BLER target	F	3.1.0	3.2.0	R4-000293
25.101	035		R99	UE Minimum TX power change	F	3.1.0	3.2.0	R4-000271
25.101	036		R99	Performance requirements for demodulation of DCH in Site Selection	F	3.1.0	3.2.0	R4-000280
25.101	037		R99	Reference compressed mode patterns	F	3.1.0	3.2.0	R4-000302
25.101	038		R99	384kbps measurement channel is replaced with 10ms TTI	F	3.1.0	3.2.0	R4-000292
25.101	039		R99	Modification to the handling of measurement equipment uncertainty	F	3.1.0	3.2.0	R4-000291

TS 25.101 V3.1.0 (1999-12)

Technical Specification

3rd Generation Partnership Project (3GPP) Technical Specification Group (TSG) RAN WG4 UE Radio transmission and Reception (FDD)



The present document has been developed within the 3rd Generation Partnership Project (3GPP™) and may be further elaborated for the purposes of 3GPP.

The present document has not been subject to any approval process by the 3GPP Organisational Partners and shall not be implemented. This Specification is provided for future development work within 3GPP only. The Organisational Partners accept no liability for any use of this Specification.

Specifications and reports for implementation of the 3GPP™ system should be obtained via the 3GPP Organisational Partners' Publications Offices.

Reference

<Workitem>

Keywords

<keyword[, keyword]>

3GPP

Postal address

Office address

Internet

secretariat@3gpp.org

Individual copies of this deliverable
can be downloaded from

<http://www.3gpp.org>

Copyright Notification

No part may be reproduced except as authorized by written permission.
The copyright and the foregoing restriction extend to reproduction in all media.

© 1999, 3GPP Organizational Partners (ARIB, CWTS, ETSI, T1, TTA, TTC).
All rights reserved.

Contents

Foreword	9
1 Scope.....	10
2 References.....	10
3 Definitions, symbols and abbreviations	10
3.1 Definitions.....	10
3.2 Symbols.....	10
3.3 Abbreviations	11
4 General.....	13
4.1 Measurement uncertainty	13
4.2 Power Classes.....	13
5 Frequency bands and channel arrangement	14
5.1 General	14
5.2 Frequency bands.....	14
5.3 TX–RX frequency separation.....	14
5.4 Channel arrangement.....	14
5.4.1 Channel spacing.....	14
5.4.2 Channel raster	14
5.4.3 Channel number.....	14
6 Transmitter characteristics	16
6.1 General	16
6.2 Transmit power	16
6.2.1 UE maximum output power.....	16
6.3 Frequency stability	16
6.4 Output power dynamics.....	16
6.4.1 Open loop power control	16
6.4.2 Inner loop power control in the uplink.....	17
6.4.2.1 Power control steps	17
6.4.2.1.1 Minimum requirement.....	17
6.4.3 Minimum transmit output power	17
6.4.3.1 Minimum requirement	17
6.5 Transmit ON/OFF power	18
6.5.1 Transmit OFF power.....	18
6.5.1.1 Minimum requirement	18
6.5.2 Transmit ON/OFF Time mask	18
6.5.2.1 Minimum requirement	18
6.5.3 Change of TFC	18
6.5.3.1 Minimum requirement	18
6.5.4 Power setting in uplink compressed mode.....	19
6.5.4.1 Minimum requirement	19
6.6 Output RF spectrum emissions.....	20
6.6.1 Occupied bandwidth	20
6.6.2 Out of band emission	20
6.6.2.1 Spectrum emission mask.....	20
6.6.2.1.1 Minimum requirement.....	20
6.6.2.2 Adjacent Channel Leakage power Ratio (ACLR).....	21
6.6.2.2.1 Minimum requirement.....	21
6.6.3 Spurious emissions	21
6.6.3.1 Minimum requirement	21
6.7 Transmit intermodulation	22
6.7.1 Minimum requirement	22
6.8 Transmit modulation	22
6.8.1 Transmit pulse shape filter.....	22
6.8.2 Modulation Accuracy	22
6.8.2.1 Minimum requirement	22
6.8.3 Peak code domain error	22

6.8.3.1	Minimum requirement	23
7.0	Receiver characteristics.....	24
7.1	General	24
7.2	Diversity characteristics	24
7.3	Reference sensitivity level.....	24
7.3.1	Minimum requirement	24
7.4	Maximum input level	24
7.4.1	Minimum requirement	24
7.5	Adjacent Channel Selectivity (ACS).....	25
7.5.1	Minimum requirement	25
7.6	Blocking characteristics	25
7.6.1	Minimum requirement	25
7.7	Spurious response.....	26
7.7.1	Minimum requirement	26
7.8	Intermodulation characteristics	26
7.8.1	Minimum requirement	26
7.9	Spurious emissions	27
7.9.1	Minimum requirement	27
8	Performance requirement.....	28
8.1	General	28
8.2	Demodulation in static propagation conditions	29
8.2.1	Demodulation of Paging Channel (PCH).....	29
8.2.1.1	Minimum requirement	29
8.2.2	Demodulation of Forward Access Channel (FACH).....	30
8.2.2.1	Minimum requirement	30
8.2.3	Demodulation of Dedicated Channel (DCH).....	31
8.2.3.1	Minimum requirement	31
8.3	Demodulation of DCH in multi-path fading propagation conditions	32
8.3.1	Single Link Performance	32
8.3.1.1	Minimum requirement	32
8.4	Demodulation of DCH in moving propagation conditions.....	34
8.4.1	Single link performance.....	34
8.4.1.1	Minimum requirement	34
8.5	Demodulation of DCH in birth-death propagation conditions	35
8.5.1	Single link performance.....	35
8.5.1.1	Minimum requirement	35
8.6	Demodulation of DCH in Base Station Transmit diversity modes.....	36
8.6.1	Demodulation of DCH in open-loop transmit diversity mode.....	36
8.6.1.1	Minimum requirement	36
8.6.2	Demodulation of DCH in closed loop transmit diversity mode.....	37
8.6.2.1	Minimum requirement	37
8.6.3	Demodulation of DCH in Site Selection Diversity Transmission mode.....	38
8.6.3.1	Minimum Requirements.....	38
8.7	Demodulation in Handover conditions.....	40
8.7.1	Inter-Cell Soft Handover Performance	40
8.7.1.1	Minimum requirement	40
8.8	Inner loop power control in downlink	41
8.8.1	Inner loop power control in the downlink.....	41
8.8.1.1	Minimum requirements	41
8.9	Outer loop power control in downlink	42
8.9.1	Outer loop power control in the downlink	42
8.9.1.1	Minimum requirements	42
8.10	Downlink compressed mode	43
8.10.1	Single link performance.....	43
8.10.1.1	Minimum requirements.....	43
Annex A (normative):	Measurement channels.....	44
A.1	General	44
A.2	UL reference measurement channel	44
A.2.1	UL reference measurement channel (12.2 kbps).....	44
A.2.2	UL reference measurement channel (64 kbps).....	45
A.2.3	UL reference measurement channel (144 kbps).....	46
A.2.4	UL reference measurement channel (384 kbps).....	47

A.3	DL reference measurement channel	49
A.3.1	DL reference measurement channel (12.2 kbps).....	49
A.3.2	DL reference measurement channel (64 kbps).....	50
A.3.3	DL reference measurement channel (144 kbps).....	51
A.3.4	DL reference measurement channel (384 kbps).....	52
A.4	DL reference compressed mode parameters.....	53
Annex B (normative): Propagation conditions.....		54
B.1	General	54
B.2	Propagation Conditions	54
B.2.1	Static propagation condition	54
B.2.2	Multi-path fading propagation conditions.....	54
B.2.3	Moving propagation conditions	54
B.2.4	Birth-Death propagation conditions.....	55
Annex C (normative): Downlink Physical Channels		56
C.1	General	56
C.2	Connection Set-up.....	56
C.3	During connection	56
C.3.1	Measurement of Rx Characteristics.....	56
C.3.2	Measurement of Performance requirements.....	56
C.3.3	Connection with open-loop transmit diversity mode.....	57
C.3.4	Connection with closed loop transmit diversity mode.....	58
Annex D (normative): Environmental conditions		59
D.1	General	59
D.2	Environmental requirements	59
D.2.1	Temperature	59
D.2.2	Voltage.....	59
D.2.3	Vibration.....	59
Annex F (Informative): UE capabilities (FDD).....		61
Annex G (Informative): Change Request History.....		62
History.....		63

Foreword

This Technical Specification has been produced by the 3GPP.

The contents of the present document are subject to continuing work within the TSG and may change following formal TSG approval. Should the TSG modify the contents of this TS, it will be re-released by the TSG with an identifying change of release date and an increase in version number as follows:

Version 3.y.z

where:

x the first digit:

Presented to TSG for information;

Presented to TSG for approval;

Indicates TSG approved document under change control.

Y the second digit is incremented for all changes of substance, i.e. technical enhancements, corrections, updates, etc.

z the third digit is incremented when editorial only changes have been incorporated in the specification.

1 Scope

This document establishes the minimum RF characteristics of the FDD mode of UTRA for the User Equipment (UE).

2 References

The following documents contain provisions, which, through reference in this text, constitute provisions of the present document.

- References are either specific (identified by date of publication, edition number, version number, etc.) or non-specific.
- For a specific reference, subsequent revisions do not apply.
- For a non-specific reference, subsequent revisions do apply.

A non-specific reference to an ETS shall also be taken to refer to later versions published as an EN with the same number.

1. TS 25.213v.x.y.z, Gain factor β (see section 4.2.1)
 2. ITU-R Recommendation SM.329-7, "Spurious emissions".
-

3 Definitions, symbols and abbreviations

3.1 Definitions

For the purposes of the present document, the following definitions apply:

Power Setting	The value of the control signal, which determines the desired transmitter, output Power. Typically, the power setting would be altered in response to power control commands
Maximum Power Setting	The highest value of the Power control setting which can be used.
Maximum output Power	This refers to the measure of average power at the maximum power setting.
Average power	
Peak Power	The instantaneous power of the RF envelope which is not expected to be exceeded for 99.9% of the time
Maximum peak power	The peak power observed when operating at a given maximum output power.
Average transmit power	The average transmitter output power obtained over any specified time interval, including periods with no transmission.
Maximum average power	The average transmitter output power obtained over any specified time interval, including periods with no transmission, when the transmit time slots are at the maximum power setting.

3.2 Symbols

For the purposes of the present document, the following symbols apply:

<symbol> <Explanation>

3.3 Abbreviations

For the purposes of the present document, the following abbreviations apply:

ACLR	Adjacent Channel Leakage power Ratio
ACS	Adjacent Channel Selectivity
AICH	Acquisition Indication Channel
BS	Base Station
BER	Bit Error Ratio
BLER	Block Error Ratio
CW	Continuous Wave (un-modulated signal)
CPICH	Common Pilot Channel
DCH	Dedicated Channel, which is mapped into Dedicated Physical Channel.
DL	Down Link (forward link)
DTX	Discontinuous Transmission
DPCH	Dedicated Physical Channel
DPCH $_E_c$	Average energy per PN chip for DPCH.
$\frac{DPCH_E_c}{I_{or}}$	The ratio of the transmit energy per PN chip of the DPCH to the total transmit power spectral density at the BS antenna connector.
EIRP	Effective Isotropic Radiated Power
E_b	Average energy per information bit for the PCCPCH, SCCPCH and DPCH, at the UE antenna connector.
$\frac{E_b}{N_t}$	The ratio of combined received energy per information bit to the effective noise power spectral density for the PCCPCH, SCCPCH and DPCH at the UE antenna connector. Following items are calculated as overhead: pilot, TPC, TFICI, CRC, tail, repetition, convolution coding and turbo coding.
E_c	Average energy per PN chip.
$\frac{E_c}{I_{or}}$	The ratio of the average transmit energy per PN chip for different fields or physical channels to the total transmit power spectral density.
FDD	Frequency Division Duplexing
FACH	Forward Access Channel
F_{uw}	Frequency of unwanted signal. This is specified in bracket in terms of an absolute frequency(s) or a frequency offset from the assigned channel frequency.
Information Data Rate	Rate of the user information, which must be transmitted over the Air Interface. For example, output rate of the voice codec.
I_o	The total received power spectral density, including signal and interference, as measured at the UE antenna connector.
I_{oc}	The power spectral density of a band limited white noise source (simulating interference from other cells) as measured at the UE antenna connector.

I_{or}	The total transmit power spectral density of the down link at the base station antenna connector.
\hat{I}_{or}	The received power spectral density of the down link as measured at the UE antenna connector.
ISCP	Given only interference is received, the average power of the received signal after de-spreading to the code and combining. Equivalent to the RSCP value but now only interference is received instead of signal.
MER	Message Error Ratio
N_t	The effective noise power spectral density at the UE antenna connector.
OCNS	Orthogonal Channel Noise Simulator, a mechanism used to simulate the users or control signals on the other orthogonal channels of a Forward link.
OCNS_ E_c	Average energy per PN chip for the OCNS.
$\frac{OCNS_E_c}{I_{or}}$	The ratio of the average transmit energy per PN chip for the OCNS to the total transmit power spectral density.
PCCPCH	Primary Common Control Physical Channel
PCH	Paging Channel
$PCCPCH \frac{E_c}{I_o}$	The ratio of the received PCCPCH energy per chip to the total received power spectral density at the UE antenna connector.
$\frac{PCCPCH_E_c}{I_{or}}$	The ratio of the average transmit energy per PN chip for the PCCPCH to the total transmit power spectral density.
PICH	Paging Indicator Channel
PPM	Parts Per Million
RACH	Random Access Channel
RSCP	Given only signal power is received, the average power of the received signal after de-spreading and combining
RSSI	Received Signal Strength Indicator
SCH	Synchronisation Channel consisting of Primary and Secondary synchronisation channels
SCCPCH	Secondary Common Control Physical Channel.
SCCPCH_ E_c	Average energy per PN chip for SCCPCH.
SIR	Signal to Interference ratio
SSDT	Site Selection Diversity Transmission
TDD	Time Division Duplexing
TFCI	Transport Format Combination Indicator
TPC	Transmit Power Control
UE	User Equipment
UL	Up Link (reverse link)
UTRA	UMTS Terrestrial Radio Access

4 General

4.1 Measurement uncertainty

The requirements given in these specifications are absolute. Compliance with these requirements is determined by comparing the measured values with the specified limits, without making allowance for measurement uncertainty.

4.2 Power Classes

For UE power classes 1 and 2, a number of RF parameter are not specified. It is intended that these are part of a later release.

5 Frequency bands and channel arrangement

5.1 General

The information presented in this section is based on a chip rate of 3.84 Mcps.

Note

1. Other chip rates may be considered in future releases.

5.2 Frequency bands

UTRA/FDD is designed to operate in either of the following paired bands;

- (a) 1920 – 1980MHz: Up-link (Mobile transmit, base receive)
2110 – 2170MHz: Down-link (Base transmit, mobile receive)
- (b)* 1850 – 1910MHz: Up-link (Mobile transmit, base receive)
1930 – 1990MHz: Down-link (Base transmit, mobile receive)

* Used in Region 2

Additional allocations in ITU region 2 are FFS

Deployment in other frequency bands is not precluded.

5.3 TX–RX frequency separation

- (a) The minimum transmit to receive frequency separation is 134.8 MHz and the maximum value is 245.2 MHz and all UE(s) shall support a TX –RX frequency separation of 190 MHz when operating in the paired band defined in sub-clause 5.2(a)
- (b) When operating in the paired band defined in sub-clause 5.2(b), all UE(s) shall support a TX-RX frequency separation of 80 MHz
- (c) UTRA/FDD can support both fixed and variable transmit to receive frequency separation.
- (d) The use of other transmit to receive frequency separations in existing or other frequency bands shall not be precluded.

5.4 Channel arrangement

5.4.1 Channel spacing

The nominal channel spacing is 5 MHz, but this can be adjusted to optimise performance in a particular deployment scenario.

5.4.2 Channel raster

The channel raster is 200 kHz, which means that the centre frequency must be an integer multiple of 200 kHz.

5.4.3 Channel number

The carrier frequency is designated by the UTRA Absolute Radio Frequency Channel Number (UARFCN). The value of the UARFCN in the IMT2000 band is defined as follows;

Table 5.1: UTRA Absolute Radio Frequency Channel Number

Uplink	$N_u = 5 * (F_{\text{uplink}} \text{ MHz})$	$0.0 \text{ MHz} \leq F_{\text{uplink}} \leq 3276.6 \text{ MHz}$ where F_{uplink} is the uplink frequency in MHz
Downlink	$N_d = 5 * (F_{\text{downlink}} \text{ MHz})$	$0.0 \text{ MHz} \leq F_{\text{downlink}} \leq 3276.6 \text{ MHz}$ where F_{downlink} is the downlink frequency in MHz

6 Transmitter characteristics

6.1 General

Unless detailed the transmitter characteristic are specified at the antenna connector of the UE. For UE with integral antenna only, a reference antenna with a gain of 0 dBi is assumed. Transmitter characteristics for UE(s) with multiple antennas/antenna connectors are FFS.

The UE antenna performance has a significant impact on system performance, and minimum requirements on the antenna efficiency are therefore intended to be included in future versions of this specification. It is recognised that different requirements and test methods are likely to be required for the different types of UE.

All the parameters in Section 6 are defined using the UL reference measurement channel (12.2 kbps) specified in Annex A.2.1 and unless stated with the UL power control ON

6.2 Transmit power

6.2.1 UE maximum output power

The following Power Classes define the maximum output power;

Table 6.1: UE Power Classes

Power Class	Maximum output power	Tolerance
1	+33 dBm	+1/-3 dB
2	+27 dBm	+1/-3 dB
3	+24 dBm	+1/-3 dB
4	+21 dBm	± 2 dB

Note

1. The tolerance of the maximum output power is below the prescribed value even for the multi-code transmission mode

6.3 Frequency stability

The UE modulated carrier frequency shall be accurate to within ± 0.1 PPM compared to carrier frequency received from the BS. These signals will have an apparent error due to BS frequency error and Doppler shift. In the later case, signals from the BS must be averaged over sufficient time that errors due to noise or interference are allowed for within the above ± 0.1 PPM figure.

Table 6.2: Frequency stability

AFC	Frequency stability
ON	within ± 0.1 PPM

6.4 Output power dynamics

Power control is used to limit the interference level

6.4.1 Open loop power control

Open loop power control is the ability of the UE transmitter to sets its output power to a specific value. The UE open loop power control tolerance is given in Table 6.3

Table 6.3: Open loop power control

Normal conditions	± 9 dB
Extreme conditions	± 12 dB

6.4.2 Inner loop power control in the uplink

Inner loop power control in the Uplink is the ability of the UE transmitter to adjust its output power in accordance with one or more TPC commands received in the downlink.

6.4.2.1 Power control steps

The power control step is the change in the UE transmitter output power in response to a single TPC command, TPC_cmd, derived at the UE.

6.4.2.1.1 Minimum requirement

The UE transmitter shall have the capability of changing the output power with a step size of 1, 2 and 3 dB according to the value of Δ_{TPC} or $\Delta_{\text{RP-TPC}}$, in the slot immediately after the TPC_cmd can be derived

- (a) The transmitter output power step due to inner loop power control shall be within the range shown in Table 6.4.
- (b) The transmitter average output power step due to inner loop power control shall be within the range shown in Table 6.5

Table 6.4: Transmitter power control range

TPC_cmd	Transmitter power control range					
	1 dB step size		2 dB step size		3 dB step size	
	Lower	Upper	Lower	Upper	Lower	Upper
+1	+0.5 dB	+1.5 dB	+1 dB	+3 dB	+1.5 dB	+4.5 dB
0	-0.5 dB	+0.5 dB	-0.5 dB	+0.5 dB	-0.5 dB	+0.5 dB
-1	-0.5 dB	-1.5 dB	-1 dB	-3 dB	-1.5 dB	-4.5 dB

Table 6.5: Transmitter average power control range

TPC_cmd	Transmitter power control range after 10 equal TPC_cmd					
	1 dB step size		2 dB step size		3 dB step size	
	Lower	Upper	Lower	Upper	Lower	Upper
+1	+8 dB	+12 dB	+16 dB	+24 dB	+24 dB	+36 dB
0	-2 dB	+2 dB	-2 dB	+2 dB	-2 dB	+2 dB
-1	-8 dB	-12 dB	-16 dB	-24 dB	-24 dB	-36 dB

6.4.3 Minimum transmit output power

The minimum controlled output power of the UE is when the power control setting is set to a minimum value. This is when both the inner loop and open loop power control indicate a minimum transmit output power is required.

6.4.3.1 Minimum requirement

The minimum transmit power shall be better than -44 dBm measured with a filter that has a Root-Raised Cosine (RRC) filter response with a roll off $\alpha = 0.22$ and a bandwidth equal to the chip rate.

6.5 Transmit ON/OFF power

6.5.1 Transmit OFF power

The transmit OFF power state is when the UE does not transmit except during UL DTX mode. This parameter is defined as the maximum output transmit power within the channel bandwidth when the transmitter is OFF.

6.5.1.1 Minimum requirement

The requirement for the transmit OFF power shall be better than -50 dBm measured with a filter that has a Root-Raised Cosine (RRC) filter response with a roll off $\alpha = 0.22$ and a bandwidth equal to the chip rate

6.5.2 Transmit ON/OFF Time mask

The time mask for transmit ON/OFF defines the ramping time allowed for the UE between transmit OFF power and transmit ON power. Possible ON/OFF scenarios are RACH or UL slotted mode

6.5.2.1 Minimum requirement

The transmit power levels versus time should meet the mask specified in figure 6.1

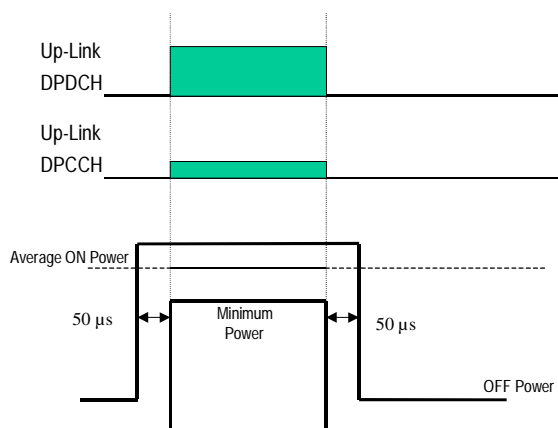

Figure 6.1: Transmit ON/OFF template

6.5.3 Change of TFC

A change of TFC (Transport Format Combination) in uplink means that the power in the uplink varies according to the change in data rate. DTX, where the DPCH is turned off, is a special case of variable data, which is used to minimise the interference between UE(s) by reducing the UE transmit power when voice, user or control information is not present.

6.5.3.1 Minimum requirement

A change of output power is required when the TFC, and thereby the data rate, is changed. The ratio of the amplitude between the DPDCH codes and the DPCCH code will vary. The power step due to a change in TFC shall be calculated in the UE so that the power transmitted on the DPCCH shall follow the inner loop power control. The power step shall then be rounded to the closest integer dB value. The accuracy of the power step, given the step size is specified in Table 6.6.

Table 6.6: Transmitter power step tolerance

Power control step size (Up or down) ΔP [dB]	Transmitter power step tolerance [dB]
1	+/- 0.5 dB
2	+/- 1.0 dB
3	+/- 1.5 dB

$4 \leq \Delta P \leq 10$	+/- 2 dB
$11 \leq \Delta P \leq 15$	+/- 3 dB
$16 \leq \Delta P \leq 20$	+/- 4 dB
$21 \leq \Delta P$	+/- 6 dB

The transmit power levels versus time should meet the mask specified in figure 6.2. When power increases the power step shall be performed before the frame boundary, when power decreases the power step shall be performed after the frame boundary.

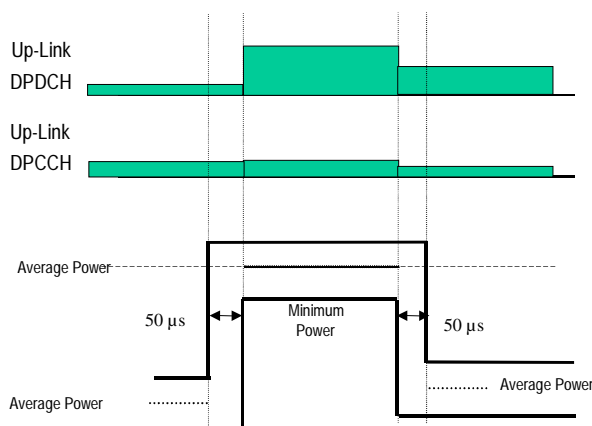

Figure 6.2 Transmit template during TFC change

6.5.4 Power setting in uplink compressed mode

Compressed mode in uplink means that the power in uplink is changed.

6.5.4.1 Minimum requirement

A change of output power is required during uplink compressed frames since the transmission of data is performed in a shorter interval. The ratio of the amplitude between the DPDCH codes and the DPCCH code will also vary. The power step due to compressed mode shall be calculated in the UE so that the energy transmitted on the pilot bits during each transmitted slot shall follow the inner loop power control. Thereby the power step during the transmitted part of a compressed frame shall be such that the power on the DPCCH follows the inner loop power control with an additional power offset during a compressed frame of $N_{pilot,N} / N_{pilot,C}$ where $N_{pilot,C}$ is the number of pilot bits per slot when in compressed mode, and $N_{pilot,N}$ is the number of pilot bits per slot in normal mode.

The power step shall then be rounded to the closest integer dB value. The accuracy of the power step, given the step size is specified in Table 6.6 in paragraph 6.5.3.1.

The transmit power levels versus time shall meet the mask specified in figure 6.3. When power increases the power step shall be performed before the actual slot boundary, when power decreases the power step shall be performed after the actual slot boundary.

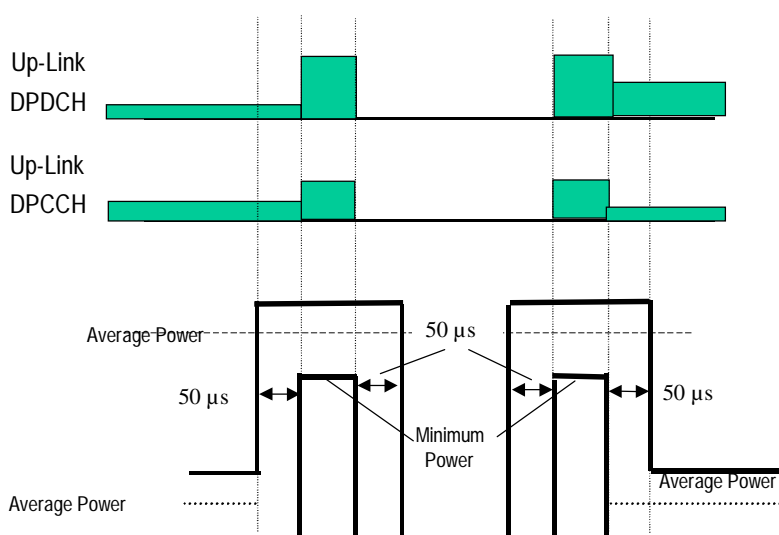

Figure 6.3 Transmit template during Compressed mode.

6.6 Output RF spectrum emissions

6.6.1 Occupied bandwidth

Occupied bandwidth is a measure of the bandwidth containing 99% of the total integrated power of the transmitted spectrum, centered on the assigned channel frequency. The occupied channel bandwidth shall be less than 5 MHz based on a chip rate of 3.84 Mcps.

6.6.2 Out of band emission

Out of band emissions are unwanted emissions immediately outside the nominal channel resulting from the modulation process and non-linearity in the transmitter but excluding spurious emissions. This out of band emission limit is specified in terms of a spectrum emission mask and Adjacent Channel Leakage power Ratio.

6.6.2.1 Spectrum emission mask

The spectrum emission mask of the UE applies to frequencies, which are between 2.5 MHz and 12.5 MHz away from the UE centre carrier frequency. The out of channel emission is specified relative to the UE output power measured in a 3.84 MHz bandwidth.

6.6.2.1.1 Minimum requirement

The power of any UE emission shall not exceed the levels specified in Table 6.7

Table 6.7 Spectrum Emission Mask Requirement

Frequency offset from carrier Δf	Minimum requirement	Measurement bandwidth
2.5 - 3.5 MHz	$-35 - 15 * (\Delta f - 2.5)$ dBc	30 kHz *
3.5 - 7.5 MHz	$-35 - 1 * (\Delta f - 3.5)$ dBc	1 MHz *
7.5 - 8.5 MHz	$-39 - 10 * (\Delta f - 7.5)$ dBc	1 MHz *
8.5 - 12.5 MHz	-49 dBc	1 MHz *

Note *

1. The first and last measurement position with a 30 kHz filter is 2.515 MHz and 3.485 MHz
2. The first and last measurement position with a 1 MHz filter is 4 MHz and 12 MHz
3. The lower limit shall be -50 dBm/3.84 MHz or which ever is higher

6.6.2.2 Adjacent Channel Leakage power Ratio (ACLR)

Adjacent Channel Leakage power Ratio (ACLR) is the ratio of the transmitted power to the power measured after a receiver filter in the adjacent channel(s). Both the transmitted power and the received power are measured with a filter that has a Root-Raised Cosine (RRC) filter response with roll-off $\alpha = 0.22$ and a bandwidth equal to the chip rate.

6.6.2.2.1 Minimum requirement

The ACLR shall be better than the value specified in Table 6.8

Table 6.8:UE ACLR

Power Class	UE channel	ACLR limit
3	+ 5 MHz or – 5 MHz	33 dB or –50 dBm which ever is higher
3	+ 10 MHz or – 10 MHz	43 dB or –50 dBm which ever is higher
4	+ 5 MHz or – 5 MHz	33 dB or –50 dBm which ever is higher
4	+ 10 MHz or –10 MHz	43 dB or –50 dBm which ever is higher

Note

1. The ACLR due to switching transients shall not exceed the limits in Table 6.8.
2. The ACLR requirements reflect what can be achieved with present state of the art technology.
3. Requirement on the UE shall be reconsidered when the state of the art technology progresses.

6.6.3 Spurious emissions

Spurious emissions are emissions which are caused by unwanted transmitter effects such as harmonics emission, parasitic emission, intermodulation products and frequency conversion products, but exclude out of band emissions.

The frequency boundary and the detailed transitions of the limits between the requirement for out band emissions and spectrum emissions are based on ITU-R Recommendations SM.329.

6.6.3.1 Minimum requirement

These requirements are only applicable for frequencies, which are greater than 12.5 MHz away from the UE centre carrier frequency

Table 6.9 General spurious emissions requirements

Frequency Bandwidth	Resolution Bandwidth	Minimum requirement
$9 \text{ kHz} \leq f < 150 \text{ kHz}$	1 kHz	-36 dBm
$150 \text{ kHz} \leq f < 30 \text{ MHz}$	10 kHz	-36 dBm
$30 \text{ MHz} \leq f < 1000 \text{ MHz}$	100 kHz	-36 dBm
$1 \text{ GHz} \leq f < 12.75 \text{ GHz}$	1 MHz	-30 dBm

Table 6.10: Additional spurious emissions requirements

Frequency Bandwidth	Resolution Bandwidth	Minimum requirement
$1893.5 \text{ MHz} < f < 1919.6 \text{ MHz}$	300 kHz	-41 dBm
$925 \text{ MHz} \leq f \leq 935 \text{ MHz}$	100 kHz	-67 dBm *
$935 \text{ MHz} < f \leq 960 \text{ MHz}$	100 kHz	-79 dBm *

1805 MHz ≤ f ≤ 1880 MHz	100 kHz	-71 dBm *
-------------------------	---------	-----------

Note

* The measurements are made on frequencies which are integer multiples of 200 kHz. As exceptions, up to five measurements with a level up to the applicable requirements defined in Table 6.9 are permitted for each UARFCN used in the measurement.

6.7 Transmit intermodulation

The transmit intermodulation performance is a measure of the capability of the transmitter to inhibit the generation of signals in its non linear elements caused by presence of the wanted signal and an interfering signal reaching the transmitter via the antenna.

6.7.1 Minimum requirement

User Equipment(s) transmitting in close vicinity of each other can produce intermodulation products, which can fall into the UE, or BS receive band as an unwanted interfering signal. The UE intermodulation attenuation is defined by the ratio of the output power of the wanted signal to the output power of the intermodulation product when an interfering CW signal is added at a level below the wanted signal. Both the wanted signal power and the IM product power are measured with a filter that has a Root-Raised Cosine (RRC) filter response with roll-off α =0.22 and a bandwidth equal to the chip rate.

The requirement of transmitting intermodulation for a carrier spacing of 5 MHz is prescribed in Table 6.11

Table 6.11 Transmit Intermodulation

Interference Signal Frequency Offset	5MHz	10MHz
Interference CW Signal Level	-40dBc	
Intermodulation Product	-31dBc	-41dBc

6.8 Transmit modulation

6.8.1 Transmit pulse shape filter

The transmit pulse shaping filter is a root-raised cosine (RRC) with roll-off α =0.22 in the frequency domain. The impulse response of the chip impulse filter $RC_0(t)$ is

$$RC_0(t) = \frac{\cos\left(\pi(1-\alpha)\frac{t}{T_c}\right) - \alpha \cos\left(\pi(1+\alpha)\frac{t}{T_c}\right)}{\pi(1-\alpha^2)\frac{t}{T_c}}$$

Where the roll-off factor α =0.22 and the chip duration is $T_c = \frac{1}{\text{chiprate}} \approx 0.26042\mu\text{s}$

6.8.2 Modulation Accuracy

The modulation accuracy is a measure of the difference between the measured waveform and the theoretical modulated waveform (the error vector). It is the square root of the ratio of the mean error vector power to the mean reference signal power expressed as a %. The measurement interval is one power control group (timeslot)

6.8.2.1 Minimum requirement

The modulation accuracy shall not exceed 17.5 % at the maximum output power

6.8.3 Peak code domain error

The code domain error is computed by projecting the error vector power onto the code domain at the maximum spreading factor. The error vector for each power code is defined as the ratio to the mean power of the reference waveform expressed in

dB. The peak code domain error is defined as the maximum value for the code domain error. The measurement interval is one power control group (timeslot)

The requirement for peak code domain error is only applicable for multi-code transmission.

6.8.3.1 Minimum requirement

The peak code domain error shall not exceed [] dB

7.0 Receiver characteristics

7.1 General

Unless otherwise stated the receiver characteristics are specified at the antenna connector of the UE. For UE(s) with an integral antenna only, a reference antenna with a gain of 0 dBi is assumed. UE with an integral antenna may be taken into account by converting these power levels into field strength requirements, assuming a 0 dBi gain antenna. Receiver characteristics for UE(s) with multiple antennas/antenna connectors are FFS.

The UE antenna performance has a significant impact on system performance, and minimum requirements on the antenna efficiency are therefore intended to be included in future versions of this specification. It is recognised that different requirements and test methods are likely to be required for the different types of UE.

All the parameters in Section 7 are defined using the DL reference measurement channel (12.2 kbps) specified in Annex A.3.1 and unless stated are with DL power control OFF

7.2 Diversity characteristics

A suitable receiver structure using coherent reception in both channel impulse response estimation and code tracking procedures is assumed. Three forms of diversity are considered to be available in UTRA/FDD:

Table 7.1: Diversity characteristics for UTRA/FDD

Time diversity	Channel coding and interleaving in both up link and down link
Multi-path diversity	Rake receiver or other suitable receiver structure with maximum combining. Additional processing elements can increase the delay-spread performance due to increased capture of signal energy.
Antenna diversity	Antenna diversity with maximum ratio combining in the base station and optionally in the mobile stations. Possibility for downlink transmit diversity in the base station.

7.3 Reference sensitivity level

The reference sensitivity is the minimum receiver input power measured at the antenna port at which the Bit Error Ratio (BER) does not exceed a specific value

7.3.1 Minimum requirement

The BER shall not exceed 0.001 for the parameters specified in Table 7.2

Table 7.2: Test parameters for reference sensitivity

Parameter	Unit	Level
DPCH_Ec	dBm/3.84 MHz	-117
\hat{I}_{or}	dBm/3.84 MHz	-106.7

7.4 Maximum input level

This is defined as the maximum receiver input power at the UE antenna port, which does not degrade the specified BER performance.

7.4.1 Minimum requirement

The BER shall not exceed 0.001 for the parameters specified in Table 7.3

Table 7.3: Maximum input level

Parameter	Unit	Level
$\frac{DPCH_Ec}{I_{or}}$	dB	-19
\hat{I}_{or}	dBm/3.84 MHz	-25

Note

1. Since the spreading factor is large ($10\log(SF)=21\text{dB}$), the majority of the total input signal consists of the OCNS interference.

7.5 Adjacent Channel Selectivity (ACS)

Adjacent Channel Selectivity (ACS) is a measure of a receiver's ability to receive a W-CDMA signal at its assigned channel frequency in the presence of an adjacent channel signal at a given frequency offset from the centre frequency of the assigned channel. ACS is the ratio of the receive filter attenuation on the assigned channel frequency to the receive filter attenuation on the adjacent channel(s).

7.5.1 Minimum requirement

The ACS shall be better than the value indicated in Table 7.4 for the test parameters specified in Table 7.5 where the BER shall not exceed 0.001

Table 7.4: Adjacent Channel Selectivity

Power Class	Unit	ACS
3	dB	33
4	dB	33

Table 7.5: Test parameters for Adjacent Channel Selectivity

Parameter	Unit	Level
DPCH_Ec	dBm/3.84 MHz	-103
\hat{I}_{or}	dBm/3.84 MHz	-92.7
I_{oac} (modulated)	dBm/3.84 MHz	-52
F_{uw} (offset)	MHz	+5 or -5

7.6 Blocking characteristics

The blocking characteristic is a measure of the receiver's ability to receive a wanted signal at its assigned channel frequency in the presence of an unwanted interferer on frequencies other than those of the spurious response or the adjacent channels, without this unwanted input signal causing a degradation of the performance of the receiver beyond a specified limit. The blocking performance shall apply at all frequencies except those at which a spurious response occur.

7.6.1 Minimum requirement

The BER shall not exceed 0.001 for the parameters specified in Table 7.6 and Table 7.7. For Table 7.7 up to (24) exceptions are allowed for spurious response frequencies in each assigned frequency channel when measured using a 1MHz step size

Table 7.6: In-band blocking

Parameter	Unit	Offset	Offset
DPCH_Ec	dBm/3.84 MHz	-114	-114
\hat{I}_{or}	dBm/3.84 MHz	-103.7	-103.7
$I_{blocking}$ (modulated)	dBm/3.84 MHz	-56	-44

F_{uw} (offset)	MHz	+10 or -10	+15 or -15
-------------------	-----	------------	------------

Table 7.7: Out of band blocking

Parameter	Unit	Band 1	Band 2	Band 3
DPCH_Ec	dBm/3.84 MHz	-114	-114	-114
\hat{I}_{or}	dBm/3.84 MHz	-103.7	-103.7	-103.7
$I_{blocking}$ (CW)	dBm	-44	-30	-15
F_{uw} For operation in frequency bands as defined in sub-clause 5.2(a)	MHz	2050 < f < 2095 2185 < f < 2230	2025 < f < 2050 2230 < f < 2255	1 < f < 2025 2255 < f < 12750
F_{uw} For operation in frequency bands as defined in sub-clause 5.2(b)	MHz	1870 < f < 1915 2005 < f < 2050	1845 < f < 1870 2050 < f < 2075	1 < f < 1845 2075 < f < 12750

Note

1. For operation in bands referenced in 5.2(a), from 2095 < f < 2110 MHz and 2170 < f < 2185 MHz, the appropriate in-band blocking or adjacent channel selectivity in section 7.5.1 shall be applied.
2. For operation in bands referenced in 5.2(b), 1915 < f < 1930 MHz and 1990 < f < 2005 MHz, the appropriate in-band blocking or adjacent channel selectivity in section 7.5.1 shall be applied

7.7 Spurious response

Spurious response is a measure of the receiver's ability to receive a wanted signal on its assigned channel frequency without exceeding a given degradation due to the presence of an unwanted CW interfering signal at any other frequency at which a response is obtained i.e. for which the blocking limit is not met.

7.7.1 Minimum requirement

The BER shall not exceed 0.001 for the parameters specified in Table 7.8

Table 7.8: Spurious Response

Parameter	Unit	Level
DPCH_Ec	dBm/3.84 MHz	-114
\hat{I}_{or}	dBm/3.84 MHz	-103.7
$I_{blocking}$ (CW)	dBm	-44
F_{uw}	MHz	Spurious response frequencies

7.8 Intermodulation characteristics

Third and higher order mixing of the two interfering RF signals can produce an interfering signal in the band of the desired channel. Intermodulation response rejection is a measure of the capability of the receiver to receive a wanted signal on its assigned channel frequency in the presence of two or more interfering signals which have a specific frequency relationship to the wanted signal.

7.8.1 Minimum requirement

The BER shall not exceed 0.001 for the parameters specified in Table 7.9

Table 7.9: Receive intermodulation characteristics

Parameter	Unit	Level
DPCH_Ec	dBm/3.84 MHz	-114
\hat{I}_{or}	dBm/3.84 MHz	-103.7
I_{ouw1} (CW)	dBm	-46
I_{ouw2} (modulated)	dBm/3.84 MHz	-46
F_{uw1} (offset)	MHz	10
F_{uw2} (offset)	MHz	20

7.9 Spurious emissions

The spurious emissions power is the power of emissions generated or amplified in a receiver that appear at the UE antenna connector.

7.9.1 Minimum requirement

The spurious emission shall be:

- (a) Less than -60 dBm/3.84 MHz at the UE antenna connector, for frequencies within the UE receive band.
- (b) Less than -57 dBm/100 kHz at the UE antenna connector, for frequencies band from 9 kHz to 1 GHz.
- (c) Less than -47 dBm/100 kHz at the UE antenna connector, for frequencies band from 1 GHz to 12.75 GHz.

8 Performance requirement

8.1 General

The performance requirements for the UE in this section are specified for the measurement channels specified in Annex A, the propagation conditions specified in Annex B and the Down link Physical channels specified in Annex C. Unless stated DL power control is OFF

Table 8.1: Summary of UE performance targets

Meas. Channels	Information Data Rate	Static	Multi-path Case 1	Multi-path Case 2	Multi-path Case 3	Multi-path Case 4	Moving	Birth / Death
		Propagation conditions / Performance metric						
PCH	128 kbps	MER< 10^{-2}	-	-	-		-	-
FACH	128 kbps	MER< 10^{-2}	-	-	-		-	-
DCH	12.2 kbps	BLER< 10^{-2}	BLER< 10^{-2}	BLER< 10^{-2}	BLER< 10^{-2}		BLER<	BLER<
	64 kbps	BLER< $10^{-1}, 10^{-2}$	BLER< $10^{-1}, 10^{-2}$	BLER< $10^{-1}, 10^{-2}$	BLER< $10^{-1}, 10^{-2}, 10^{-3}$		BLER<	BLER<
	144 kbps	BLER< $10^{-1}, 10^{-2}$	BLER< $10^{-1}, 10^{-2}$	BLER< $10^{-1}, 10^{-2}$	BLER< $10^{-1}, 10^{-2}, 10^{-3}$		-	-
	384 kbps	BLER< $10^{-1}, 10^{-2}$	BLER< $10^{-1}, 10^{-2}$	BLER< $10^{-1}, 10^{-2}$	BLER< $10^{-1}, 10^{-2}, 10^{-3}$		-	-

8.2 Demodulation in static propagation conditions

8.2.1 Demodulation of Paging Channel (PCH)

The receive characteristics of the paging channel in the static environment is determined by the Paging Message Error Ratio (MER). MER is measured at the data rate specified for the paging channel. The UE sleep mode has an upper limit after which it must wake up and demodulate the paging channel and associated paging messages.

8.2.1.1 Minimum requirement

For the parameters specified in Table 8.2 the MER shall not exceed the piece-wise linear MER curve specified by the points in Table 8.3

Table 8.2 PCH parameters in static propagation conditions

Parameter	Unit	Value
$\frac{DPCH_E_c}{I_{or}}$	dB	
$\frac{SCCPCH_E_c}{I_{or}}$	dB	
\hat{I}_{or}/I_{oc}	dB	-1
I_{oc}	dBm/3.84 MHz	-60
Paging Data Rate		
$PCH\ E_b/N_t$	dB	

Table 8.3: PCH requirement in static propagation conditions

$PCH\ E_b/N_t$	MER
TBD	TBD
TBD	TBD
TBD	TBD

8.2.2 Demodulation of Forward Access Channel (FACH)

The receive characteristics of the Forward Access Channel (FACH) in the static environment are determined by the average message error Ratio (MER). MER is measured at the data rate specified for the FACH.

8.2.2.1 Minimum requirement

For the parameters specified in Table 8.4 the MER shall not exceed the piece-wise linear MER curve specified by the points in table 8.5

Table 8.4: FACH parameters in static propagation conditions

Parameter	Unit	Value
$\frac{DPCH_E_c}{I_{or}}$	dB	
$\frac{SCCPCH_E_c}{I_{or}}$	dB	
\hat{I}_{or}/I_{oc}	dB	-1
I_{oc}	dBm/3.84 MHz	-60
Control Data Rate	?	
$FACH E_b/N_t$	dB	

Table 8.5: FACH requirements in static propagation conditions

$FACH E_b/N_t$	MER
TBD	TBD
TBD	TBD
TBD	TBD

8.2.3 Demodulation of Dedicated Channel (DCH)

The receive characteristic of the Dedicated Channel (DCH) in the static environment is determined by the Block Error Ratio (BLER). BLER is specified for each individual data rate of the DCH. DCH is mapped into the Dedicated Physical Channel (DPCH).

8.2.3.1 Minimum requirement

For the parameters specified in Table 8.6 the BLER shall not exceed the piece-wise linear BLER curve specified by the points in table 8.7

Table 8.6: DCH parameters in static propagation conditions

Parameter	Unit	Test 1	Test 2	Test 3	Test 4
\hat{I}_{or}/I_{oc}	dB	-1			
I_{oc}	dBm/3.84 MHz	-60			
Information Data Rate	kbps	12.2	64	144	384

Table 8.7: DCH requirements in static propagation conditions

Test Number	$\frac{DPCH_E_c}{I_{or}}$	BLER
1	-16.6 dB	10^{-2}
2	-13.1 dB	10^{-1}
	-12.8 dB	10^{-2}
3	-9.9 dB	10^{-1}
	-9.8 dB	10^{-2}
4	-5.6 dB	10^{-1}
	-5.5 dB	10^{-2}

8.3 Demodulation of DCH in multi-path fading propagation conditions

8.3.1 Single Link Performance

The receive characteristics of the Dedicated Channel (DCH) in different multi-path fading environments are determined by the Block Error Ratio (BLER) values. BLER is measured for the each of the individual data rate specified for the DPCH. DCH is mapped into in Dedicated Physical Channel (DPCH).

8.3.1.1 Minimum requirement

For the parameters specified in Table 8.8, 8.10 and 8.12 the BLER shall not exceed the associated piece-wise linear BLER curves specified by the points in Table 8.9, 8.11 and 8.13

Table 8.8: Test Parameters for DCH in multi-path fading propagation conditions (Case 1)

Parameter	Unit	Test 1	Test 2	Test 3	Test 4
\hat{I}_{or}/I_{oc}	dB	9			
I_{oc}	dBm/3.84 MHz	-60			
Information Data Rate	kbps	12.2	64	144	384

Table 8.9: Test requirements for DCH in multi-path fading propagation conditions (Case 1)

Test Number	$\frac{DPCH - E_c}{I_{or}}$	BLER
1	-15.0 dB	10^{-2}
2	-13.9 dB	10^{-1}
	-10.0 dB	10^{-2}
3	-10.6 dB	10^{-1}
	-6.8 dB	10^{-2}
4	-6.3 dB	10^{-1}
	-2.2 dB	10^{-2}

Table 8.10: DCH parameters in multi-path fading propagation conditions (Case 2)

Parameter	Unit	Test 5	Test 6	Test 7	Test 8
\hat{I}_{or}/I_{oc}	dB	-3	-3	3	6
I_{oc}	dBm/3.84 MHz	-60			
Information Data Rate	kbps	12.2	64	144	384

Table 8.11: DCH requirements in multi-path fading propagation (Case 2)

Test Number	$\frac{DPCH_E_c}{I_{or}}$	BLER
5	-7.7 dB	10^{-2}
6	-6.4 dB	10^{-1}
	-2.7 dB	10^{-2}
7	-8.1 dB	10^{-1}
	-5.1 dB	10^{-2}
8	-5.5 dB	10^{-1}
	-3.2 dB	10^{-2}

Table 8.12: DCH parameters in multi-path fading propagation conditions (Case 3)

Parameter	Unit	Test 9	Test 10	Test 11	Test 12
\hat{I}_{or}/I_{oc}	dB	-3	-3	3	6
I_{oc}	dBm/3.84 MHz	-60			
Information Data Rate	kbps	12.2	64	144	384

Table 8.13: DCH requirements in multi-path fading propagation conditions (Case 3)

Test Number	$\frac{DPCH_E_c}{I_{or}}$	BLER
9	-11.8 dB	10^{-2}
10	-8.1 dB	10^{-1}
	-7.4 dB	10^{-2}
	-6.8 dB	10^{-3}
11	-9.0 dB	10^{-1}
	-8.5 dB	10^{-2}
	-8.0 dB	10^{-3}
12	-6.0 dB	10^{-1}
	-5.5 dB	10^{-2}
	-5.0 dB	10^{-3}

8.4 Demodulation of DCH in moving propagation conditions

8.4.1 Single link performance

The receive single link performance of the Dedicated Traffic Channel (DCH) in dynamic moving propagation conditions are determined by the Block Error Ratio (BLER) values. BLER is measured for the each of the individual data rate specified for the DPCH. DCH is mapped into Dedicated Physical Channel (DPCH).

8.4.1.1 Minimum requirement

For the parameters specified in Table 8.14 the BLER shall not exceed the piece-wise linear BLER curve specified in points in Table 8.15

Table 8.14: DCH parameters in moving propagation conditions

Parameter	Unit	Test 1	Test 2
\hat{I}_{or}/I_{oc}	dB	-1	
I_{oc}	dBm/3.84 MHz	-60	
Information Data Rate	kbps	12.2	64

Table 8.15: DCH requirements in moving propagation conditions

Test Number	$\frac{DPCH - E_c}{I_{or}}$	BLER
1		
2		

8.5 Demodulation of DCH in birth-death propagation conditions

8.5.1 Single link performance

The receive single link performance of the Dedicated Traffic Channel (DCH) in dynamic birth-death propagation conditions are determined by the Block Error Ratio (BLER) values. BER is measured for the each of the individual data rate specified for the DPCH. DCH is mapped into Dedicated Physical Channel (DPCH).

8.5.1.1 Minimum requirement

For the parameters specified in Table 8.16, the BLER shall not exceed the piece-wise linear BLER curve in the points in Table 8.17

Table 8.16: DCH parameters in birth-death propagation conditions

Parameter	Unit	Test 1	Test 2
\hat{I}_{or}/I_{oc}	dB	-1	
I_{oc}	dBm/3.84 MHz	-60	
Information Data Rate	kbps	12.2	64

Table 8.17: DCH requirements in birth-death propagation conditions

Test Number	$\frac{DPCH_E_c}{I_{or}}$	BLER
1		
2		

8.6 Demodulation of DCH in Base Station Transmit diversity modes

8.6.1 Demodulation of DCH in open-loop transmit diversity mode

The receive characteristic of the Dedicated Channel (DCH) in open loop transmit diversity mode is determined by the Block Error Ratio (BLER). DCH is mapped into in Dedicated Physical Channel (DPCH)

8.6.1.1 Minimum requirement

For the parameters specified in Table 8.18 the BLER shall not exceed the associated piece-wise linear BLER curve specified by the points in Table 8.19

**Table 8.18: Test parameters for DCH reception in an open loop transmit diversity scheme.
(Propagation condition: Case 1)**

Parameter	Unit	Test 1
\hat{I}_{or}/I_{oc}	dB	[]
I_{oc}	dBm/3.84 MHz	-60
Information data rate	kbps	12.2

Table 8.19: Test requirements for DCH reception in open loop transmit diversity scheme.

Test Number	$\frac{DPCH_E_c}{I_{or}}$ (antenna 1/2)	BLER
1		

8.6.2 Demodulation of DCH in closed loop transmit diversity mode

The receive characteristic of the dedicated channel (DCH) in closed loop transmit diversity mode is determined by the Block Error Ratio (BLER). DCH is mapped into in Dedicated Physical Channel (DPCH).

8.6.2.1 Minimum requirement

For the parameters specified in Table 8.20 the BLER shall not exceed the associated piece-wise linear BLER curves specified by the points in Table 8.21.

**Table 8.20: Test Parameters for DCH Reception in closed loop transmit diversity mode
(Propagation condition: Case 1)**

Parameter	Unit	Test 1 (Mode 1)	Test 2 (Mode 2)
\hat{I}_{or}/I_{oc}	dB	[]	[]
I_{oc}	dBm/3.84 MHz	-60	-60
Information data rate	kbps	12.2	12.2
Feedback error rate	%	4	4

Table 8.21: Test requirements for DCH reception in closed loop transmit diversity mode.

Test Number	$\frac{DPCH_E_c}{I_{or}} (2)$	BLER
1		
2		

² This is the total power from both antennas. Power sharing between antennas are feedback mode dependent as specified in TS25.214

8.6.3 Demodulation of DCH in Site Selection Diversity Transmission mode

The bit error characteristics of UE receiver is determined in Site Selection Diversity Transmission (SSDT) mode. Two BS emulators are required for this performance test. The delay profiles of signals received from different base stations are assumed to be the same but time shifted by 10 chip periods (2604 ns).

8.6.3.1 Minimum Requirements

For the parameters specified in Table 8.22, the BLER shall not exceed the piece-wise linear BLER curve specified by the points in Table 8.23

**Table 8.22: DCH parameters in multi-path propagation conditions during SSDT mode
(Propagation condition: Case 1)**

Parameter	Unit	Test 1	Test 2	Test 3	Test 4
$\frac{CPICH_E_c}{I_{or}}$ (for Cell 1)	dB	-10	-13	-10	-10
$\frac{CPICH_E_c}{I_{or}}$ (for Cell 2)	dB	-10	-10	-10	-13
$\frac{DPCH_E_{c1}}{I_{or}} / \frac{DPCH_E_{c2}}{I_{or}}^*$	dB	0	-3	0	+3
\hat{I}_{or1}/I_{oc}	dB	9	6	9	9
\hat{I}_{or2}/I_{oc}	dB	9	9	9	6
I_{oc}	dBm/3.84 MHz	-60			
Information Data Rate	kbps	12.2	12.2	12.2	12.2
Number of FBI bits assigned to "S" Field		1	1	2	2
Code word Set		Long	Long	Short	Short

*Note: $DPCH_E_c/I_{or}$ value applies whenever DPDCH in the cell is transmitted

Table 8.23: DCH requirements in multi-path propagation conditions during SSDT Mode

Test Number	$\frac{DPCH_E_c}{I_{or}}$	BLER
1		10^{-1}
		10^{-2}
2		10^{-1}
		10^{-2}
3		10^{-1}
		10^{-2}
4		10^{-1}
		10^{-2}

8.7 Demodulation in Handover conditions

8.7.1 Inter-Cell Soft Handover Performance

The bit error rate characteristics of UE is determined during an inter-cell soft handover. During the soft handover a UE receives signals from different Base Stations. A UE has to be able to demodulate two PCCPCH channels and to combine the energy of DCH channels. Delay profiles of signals received from different Base Stations are assumed to be the same but time shifted by 10 chips.

The receive characteristics of the different channels during inter-cell handover are determined by the average Block Error Ratio (BLER) values.

8.7.1.1 Minimum requirement

For the parameters specified in Table 8.24, the BLER shall not exceed the piece-wise linear BLER curve specified by the points in Table 8.25

Table 8.24: DCH parameters in multi-path propagation conditions during Soft Handoff (Case 3)

Parameter	Unit	Test 1	Test 2	Test 3	Test 4
$\frac{DPCH_E_c}{I_{or}}$					
\hat{I}_{or1}/I_{oc} and \hat{I}_{or2}/I_{oc}	dB	0	0	3	6
I_{oc}	dBm/3.84 MHz				
Information data Rate	kbps	12.2	64	144	384

Table 8.25: DCH requirements in multi-path propagation conditions during Soft Handoff (Case 3)

Test Number	$\frac{DPCH_E_c}{I_{or}}$	BLER
1		
2		
3		
4		

8.8 Inner loop power control in downlink

Performance of the inner loop power control in downlink is determined by the Block Error Ratio (BLER) values and by the measured average transmitted DPCH_Ec/I_{or} value.

8.8.1 Inner loop power control in the downlink

8.8.1.1 Minimum requirements

For the parameters specified in Table 8.26, the BLER and DPCH_Ec/I_{or} value shall not exceed the values specified in Table 8.27.

Note

1. Power control is ON during the test.
2. Power control step size is 1 dB.

Table 8.26: Test parameters for downlink inner loop power control

Parameter	Unit	Test 1	Test 2
\hat{I}_{or}/I_{oc}	dB	9	-1
I_{oc}	dBm/3.84 MHz	-60	-60
Information Data Rate	kbps	12.2	12.2
TFCI	-	on	on
Propagation Conditions		Case 4	Case 4
SIR target		FFS	FFS

Table 8.27: Requirements in downlink inner loop power control

Parameter	Unit	Test 1	Test 2
$\frac{DPCH_E_c}{I_{or}}$	dB	FFS	FFS
BLER on TCH		0.01	0.01
Confidence level for $\frac{DPCH_E_c}{I_{or}}$	%		

8.9 Outer loop power control in downlink

Outer loop power control in the downlink is the ability of the UE receiver to maintain the suitable target for the inner loop closed loop PC according to the required link quality set by the network.

8.9.1 Outer loop power control in the downlink

8.9.1.1 Minimum requirements

For the parameters specified in Table 8.28 the downlink $\frac{DPCH_E_c}{I_{or}}$ power shall be below the specified value and the reported quality value shown in table 8.29

Note

1. Power control is ON during the test.
2. The averaging time T shall be long enough to minimize the previous quality target impact to the result.

Table 8.28 Test parameter for downlink outer loop power control

Parameter	Unit	Test 1	Test 2
\hat{I}_{or}/I_{oc}	dB	5	
I_{oc}	dBm/3.84 MHz	-60	
Information Data Rate	kbps	12.2	
TFCI	-	On	
Reporting delay, or averaging period, T	ms	[]	[]
Propagation condition		Case 4	

Table 8.29: Requirements in downlink outer loop power control

Parameter	Unit	Test 1	Test 2
$\frac{DPCH_E_c}{I_{or}}$	dB	[max. needed channel power]	[max. needed channel power]
Target quality value		FFS	FFS
Reported quality value			
Confidence level			

8.10 Downlink compressed mode

Downlink compressed mode is used to create gaps in the downlink transmission, to allow the UE to make measurements on other frequencies.

8.10.1 Single link performance

The receiver single link performance of the Dedicated Traffic Channel (DCH) in compressed mode is determined by the Block Error Ratio (BLER), average power in the downlink and the maximum power in the uplink.

The compressed mode parameters are given in Annex A.4.

8.10.1.1 Minimum requirements

For the parameters specified in Table 8.30 the average downlink $\frac{DPCH_E_c}{I_{or}}$ power shall be below the specified value for the reported BLER shown in table 8.31. The uplink DPDCH power shall be below the specified value.

Note

1. Inner loop power control is ON during the test.

Table 8.30: Test parameter for downlink compressed mode

Parameter	Unit	Test 1
\hat{I}_{or}/I_{oc}	dB	9
I_{oc}	dBm/3.84 MHz	-60
Information Data Rate	kbps	12.2
TFCI	-	On
Propagation condition		Case 2

Table 8.31: Requirements in downlink compressed mode

Parameter	Unit	Test 1
$\frac{DPCH_E_c}{I_{or}}$	dB	
Target quality		
Downlink BLER		
Uplink DPDCH	dBm	[Maximum power/slot]
Confidence level	%	

Annex A (normative): Measurement channels

A.1 General

The measurement channels in this annex are defined to derive the requirements in section 6, 7 and 8. The measurement channels represent example configuration of radio access bearers for different data rates.

The measurement channel for 12.2 kbps shall be supported by any UE both in up- and downlink. Support for other measurement channels is depending on the UE Radio Access capabilities.

A.2 UL reference measurement channel

A.2.1 UL reference measurement channel (12.2 kbps)

The parameters for the 12.2 kbps UL reference measurement channel are specified in Table A.1 and Table A.2. The channel coding for information is shown in figure A.1

Table A.1: UL reference measurement channel physical parameters (12.2 kbps)

Parameter	Unit	Level
Information bit rate	kbps	12.2
DPDCH	kbps	60
DPCCH	kbps	15
DPCCH/DPDCH	dB	-6
TFCI	-	On
Repetition	%	23

Table A.2: UL reference measurement channel, transport channel parameters (12.2 kbps)

Parameters	DCCH	DTCH
Transport Channel Number	1 (TBD by WG2)	2 (TBD by WG2)
Transport Block Size	96	244
Transport Block Set Size	96	244
Transmission Time Interval	40 ms	20 ms
Type of Error Protection	Convolution Coding	Convolution Coding
Coding Rate	1/3	1/3
Static Rate Matching parameter	1.0	1.0
Size of CRC	16	16
Position of TrCH in radio frame	Fixed	fixed

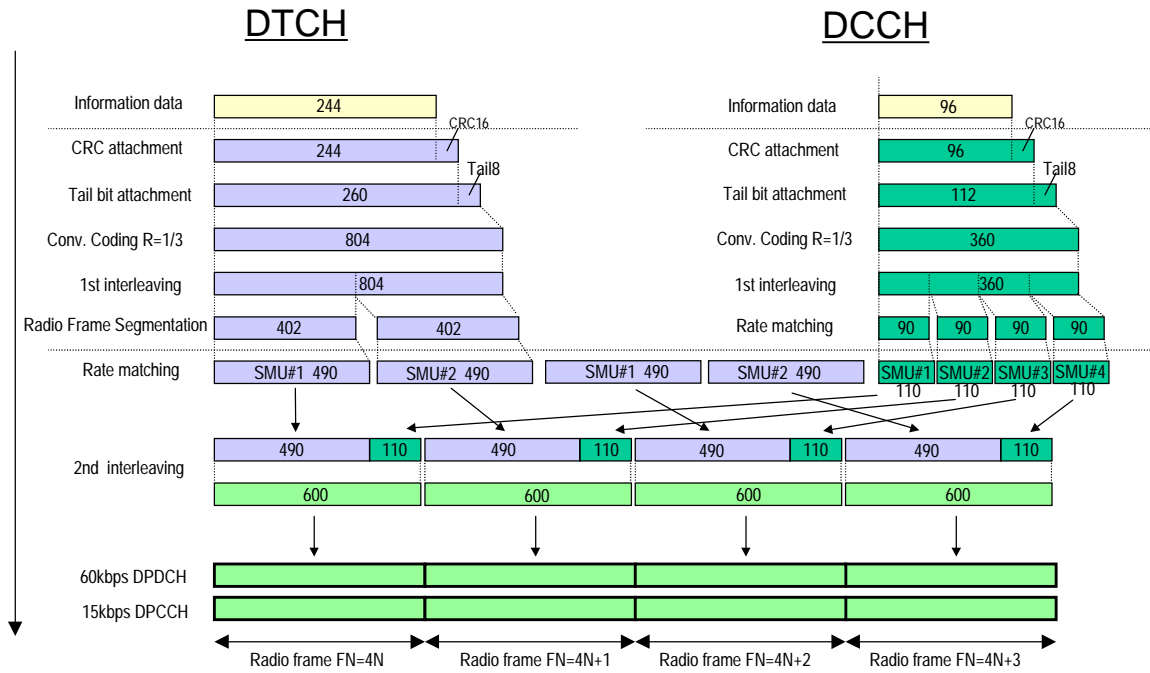

Figure A.1(Informative): Channel coding of UL reference measurement channel (12.2 kbps)

A.2.2 UL reference measurement channel (64 kbps)

The parameters for the 64 kbps UL reference measurement channel are specified in Table A.3 and Table A.4. The channel coding for information is shown in figure A.2. This measurement channel is not currently used in TS25.101 but can be used for future requirements.

Table A.3: UL reference measurement channel (64 kbps)

Parameter	Unit	Level
Information bit rate	kbps	64
DPDCH	kbps	240
DPCCH	kbps	15
DPCCH/DPDCH	dB	-9
TFCI	-	On
Repetition	%	18

Table A.4: UL reference measurement channel, transport channel parameters (64 kbps)

Parameter	DCCH	DTCH
Transport Channel Number	1 (TBD by WG2)	2 (TBD by WG2)
Transport Block Size	96	1280
Transport Block Set Size	96	1280
Transmission Time Interval	40 ms	20 ms
Type of Error Protection	Convolution Coding	Turbo Coding
Coding Rate	1/3	1/3
Static Rate Matching parameter	1.0	1.0
Size of CRC	16	16

Position of TrCH in radio frame	Fixed	Fixed
---------------------------------	-------	-------

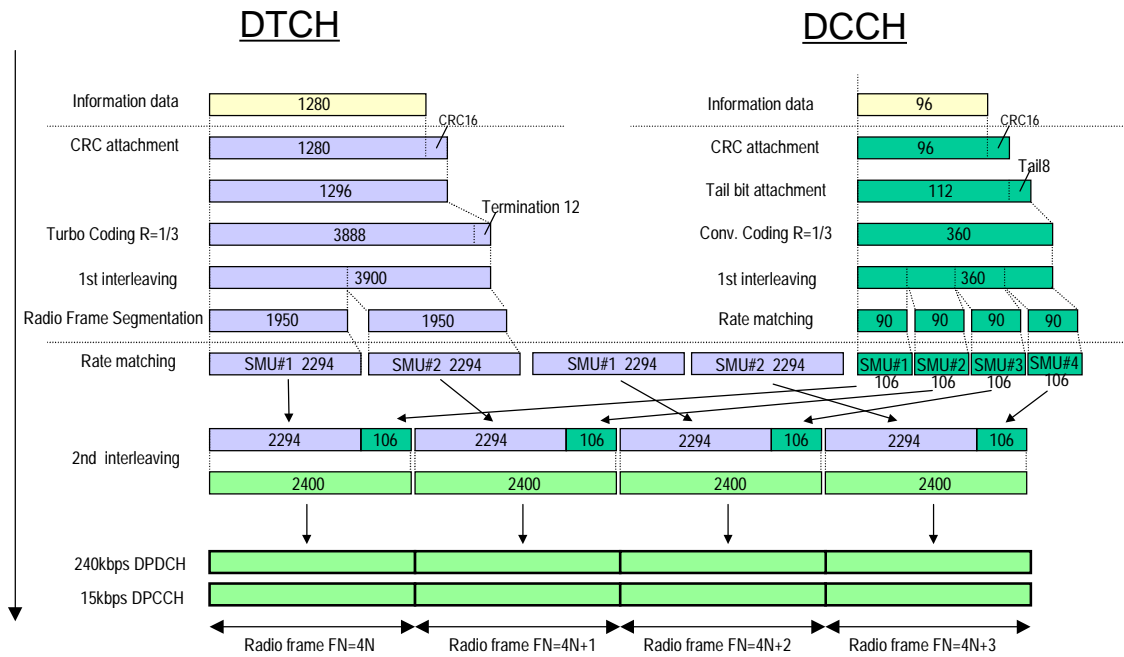

Figure A.2 (Informative): Channel coding of UL reference measurement channel (64 kbps)

A.2.3 UL reference measurement channel (144 kbps)

The parameters for the 144 kbps UL reference measurement channel are specified in Table A.5 and Table A.6. The channel coding for information is shown in Figure A.3. This measurement channel is not currently used in TS25.101 but can be used for future requirements.

Table A.5: UL reference measurement channel (144 kbps)

Parameter	Unit	Level
Information bit rate	kbps	144
DPDCH	kbps	480
DPCCH	kbps	15
DPCCH/DPDCH	dB	-12
TFCI	-	On
Repetition	%	8

Table A.6: UL reference measurement channel, transport channel parameters (144kbps)

Parameters	DCCH	DTCH
Transport Channel Number	1 (TBD by WG2)	2 (TBD by WG2)
Transport Block Size	96	2880
Transport Block Set Size	96	2880
Transmission Time Interval	40 ms	20 ms
Type of Error Protection	Convolution Coding	Turbo Coding
Coding Rate	1/3	1/3

Static Rate Matching parameter	1.0	1.0
Size of CRC	16	16
Position of TrCH in radio frame	Fixed	Fixed

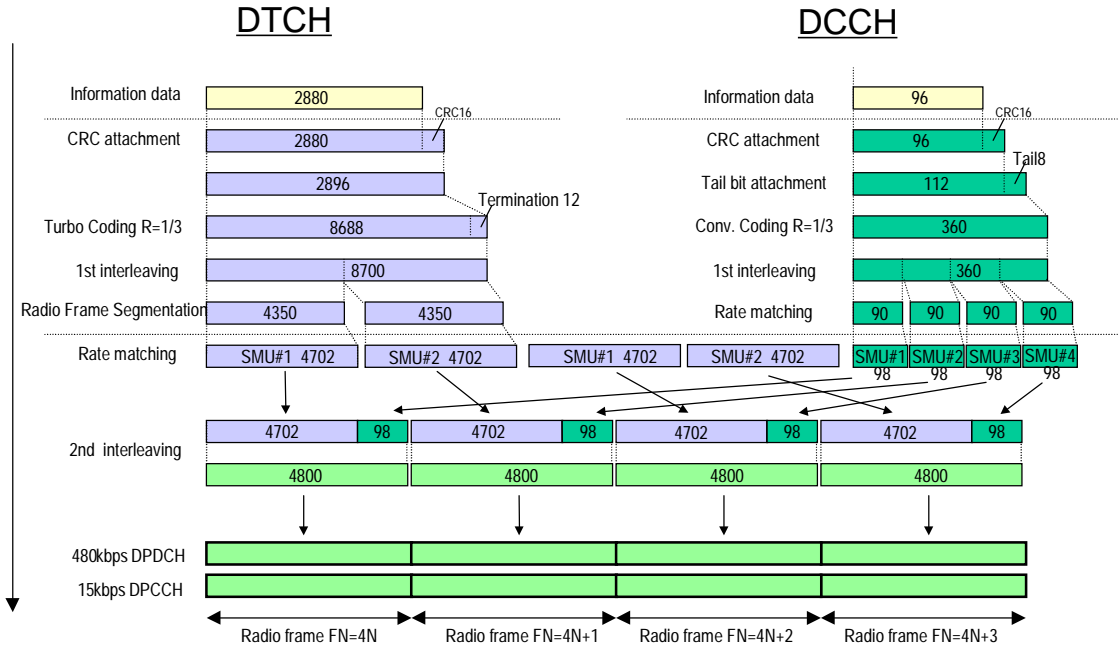

Figure A.3 (Informative): Channel coding of UL reference measurement channel (144 kbps)

A.2.4 UL reference measurement channel (384 kbps)

The parameters for the 384 kbps UL reference measurement channel are specified in Table A.7 and Table A.8. The channel coding for information is shown in Figure A.4. This measurement channel is not currently used in TS25.101 but can be used for future requirements.

Table A.7: UL reference measurement channel (384 kbps)

Parameter	Unit	Level
Information bit rate	kbps	384
DPDCH	kbps	960
DPCCH	kbps	15
DPCCH/DPDCH	dB	-12
TFCI	-	On
Puncturing	%	18

Table A.8: UL reference measurement channel, transport channel parameters (384 kbps)

Parameter	DCCH	DTCH
Transport Channel Number	1 (TBD by WG2)	2 (TBD by WG2)
Transport Block Size	96	3840

Transport Block Set Size	96	7680
Transmission Time Interval	40 ms	20 ms
Type of Error Protection	Convolution Coding	Turbo Coding
Coding Rate	1/3	1/3
Static Rate Matching parameter	1.0	1.0
Size of CRC	16	16
Position of TrCH in radio frame	Fixed	Fixed

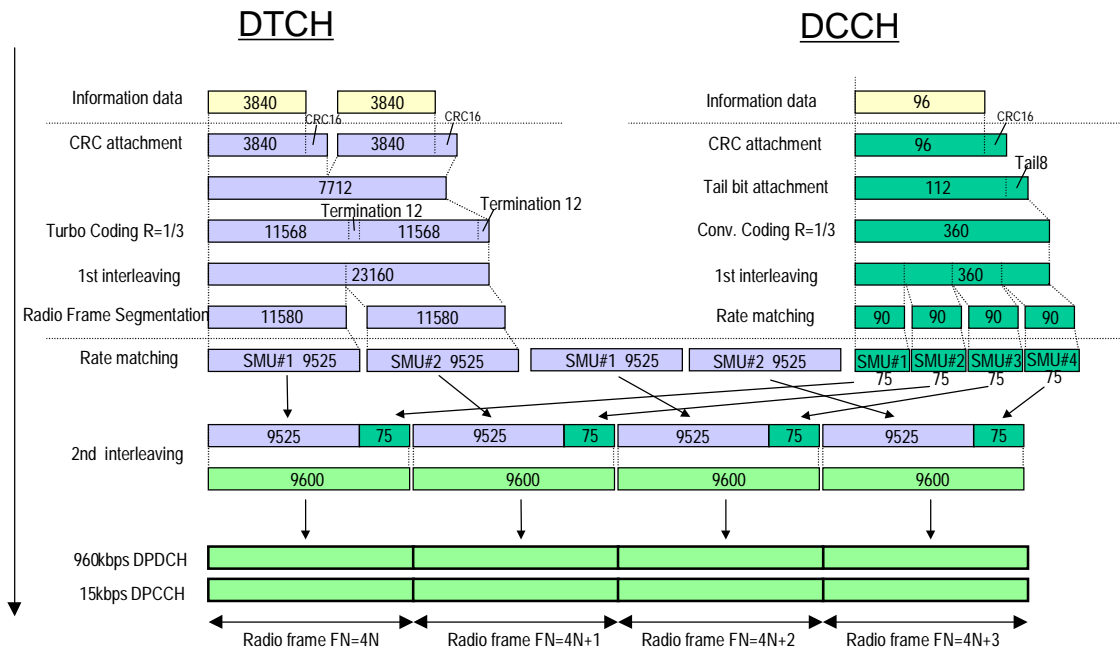

Figure A.4 (Informative): Channel coding of UL reference measurement channel (384 kbps)

A.3 DL reference measurement channel

A.3.1 DL reference measurement channel (12.2 kbps)

The parameters for the 12.2 Kbps DL reference measurement channel are specified in Table A. 9 and Table A.10. The channel coding is shown for information in figure A.5

Table A.9: DL reference measurement channel physical parameters (12.2 kbps)

Parameter	Unit	Level
Information bit rate	kbps	12.2
DPCH	ksps	30
TFCI	-	On
Puncturing	%	14.5

Table A.10: DL reference measurement channel, transport channel parameters (12.2 kbps)

Parameter	DCCH	DTCH
Transport Channel Number	1 (TBD by WG2)	2 (TBD by WG2)
Transport Block Size	96	244
Transport Block Set Size	96	244
Transmission Time Interval	40 ms	20 ms
Type of Error Protection	Convolution Coding	Convolution Coding
Coding Rate	1/3	1/3
Static Rate Matching parameter	1.0	1.0
Size of CRC	16	16
Position of TrCH in radio frame	fixed	fixed

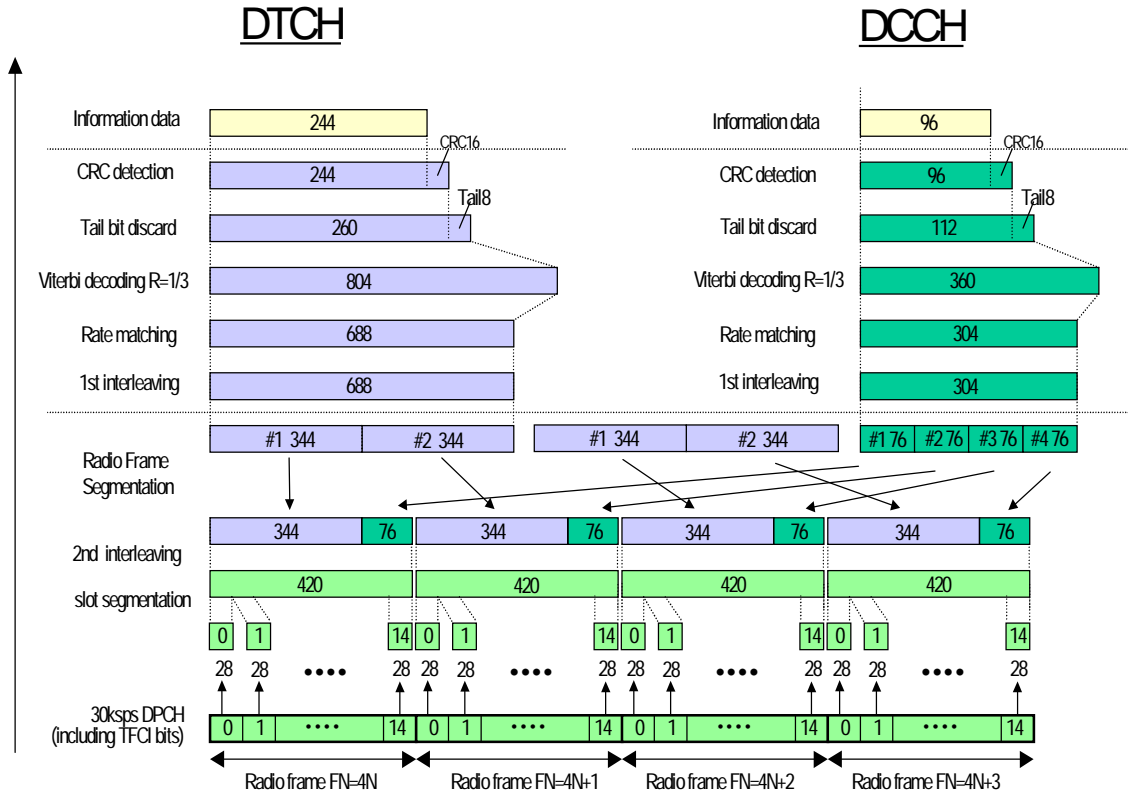

Figure A.5 (Informative): Channel coding of DL reference measurement channel (12.2 kbps)

A.3.2 DL reference measurement channel (64 kbps)

The parameters for the DL reference measurement channel for 64 kbps are specified in Table A.11 and Table A.12. The channel coding is shown for information in Figure A.6

Table A.11: DL reference measurement channel physical parameters (64 kbps)

Parameter	Unit	Level
Information bit rate	kbps	64
DPCH	ksps	120
TFCI	-	On
Repetition	%	2.9

Table A.12: DL reference measurement channel, transport channel parameters (64 kbps)

Parameter	DCCH	DTCH
Transport Channel Number	1 (TBD by WG2)	2 (TBD by WG2)
Transport Block Size	96	1280
Transport Block Set Size	96	1280
Transmission Time Interval	40 ms	20 ms
Type of Error Protection	Convolution Coding	Turbo Coding
Coding Rate	1/3	1/3
Static Rate Matching parameter	1.0	1.0
Size of CRC	16	16

Position of TrCH in radio frame	fixed	fixed
---------------------------------	-------	-------

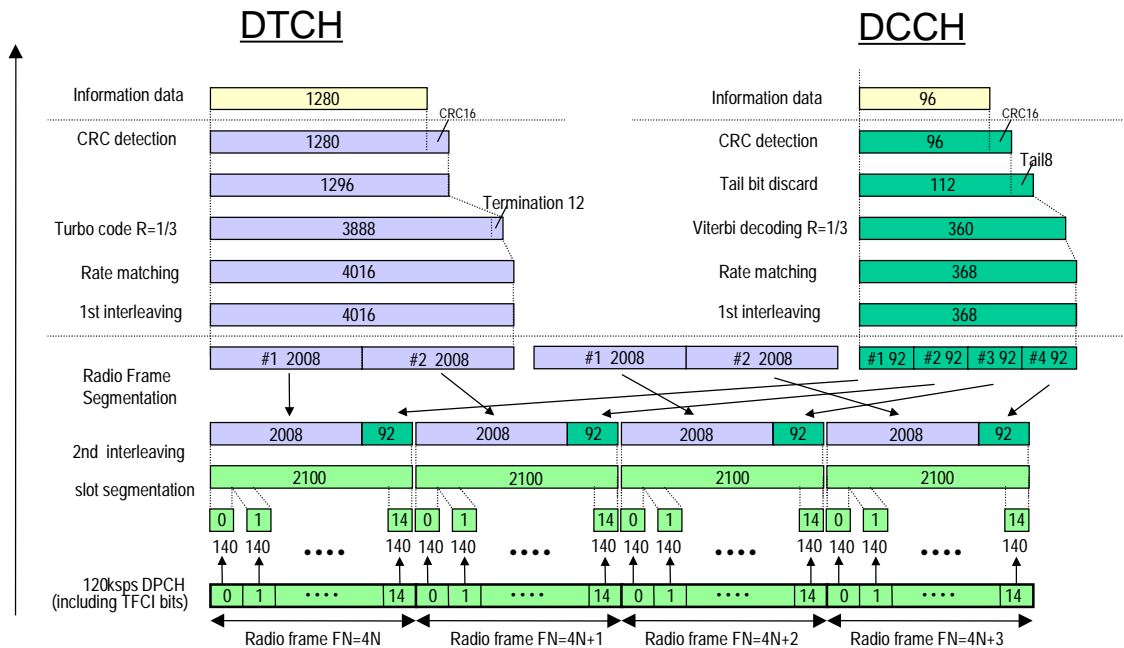

Figure A.6 (Informative): Channel coding of DL reference measurement channel (64 kbps)

A.3.3 DL reference measurement channel (144 kbps)

The parameters for the DL measurement channel for 144 kbps are specified in Table A.13 and Table A.14. The channel coding is shown for information in Figure A.7

Table A.13: DL reference measurement channel physical parameters (144 kbps)

Parameter	Unit	Level
Information bit rate	kbps	144
DPCH	ksps	240
TFCI	-	On
Puncturing	%	2.7

Table A.14: DL reference measurement channel, transport channel parameters (144 kbps)

Parameter	DCCH	DTCH
Transport Channel Number	1 (TBD by WG2)	2 (TBD by WG2)
Transport Block Size	96	2880
Transport Block Set Size	96	2880
Transmission Time Interval	40 ms	20 ms
Type of Error Protection	Convolution Coding	Turbo Coding
Coding Rate	1/3	1/3

Static Rate Matching parameter	1.0	1.0
Size of CRC	16	16
Position of TrCH in radio frame	fixed	fixed

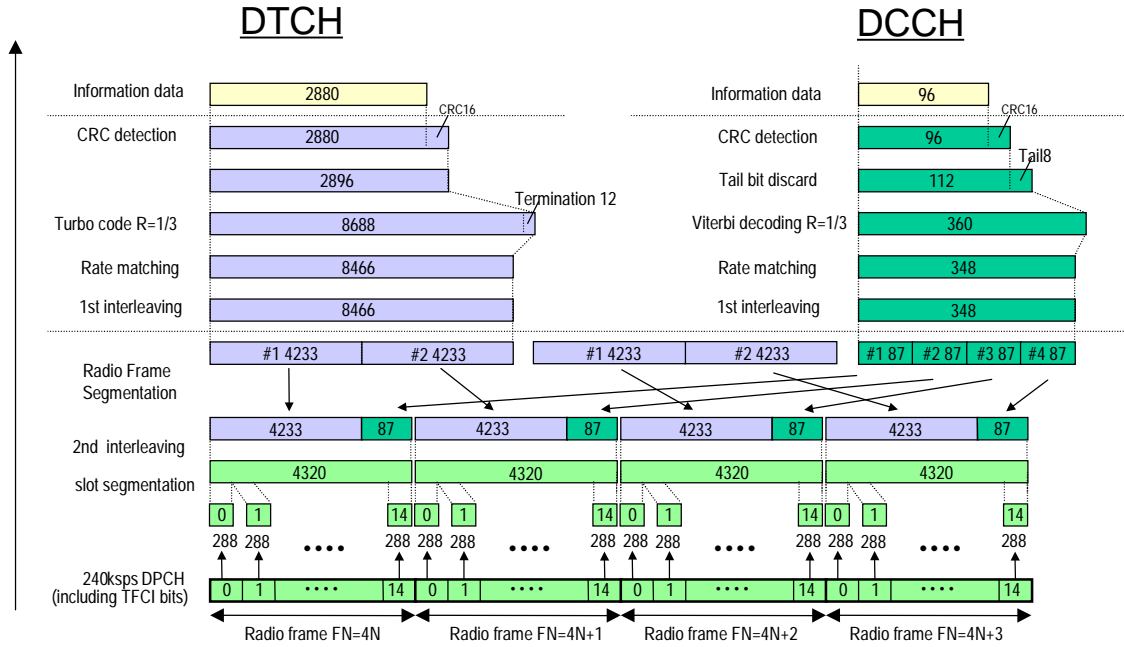

Figure A.7 (Informative): Channel coding of DL reference measurement channel (144 kbps)

A.3.4 DL reference measurement channel (384 kbps)

The parameters for the DL measurement channel for 384 kbps are specified in Table A.15 and Table A.16. The channel coding is shown for information in Figure A.8

Table A.15: DL reference measurement channel, physical parameters (384 kbps)

Parameter	Unit	Level
Information bit rate	kbps	384
DPCH	ksps	480
TFCI		On
Puncturing	%	22

Table A.16: DL reference measurement channel, transport channel parameters (384 kbps)

Parameter	DCCH	DTCH
Transport Channel Number	1 (TBD by WG2)	2 (TBD by WG2)
Transport Block Size	96	3840
Transport Block Set Size	96	7680
Transmission Time Interval	40 ms	20 ms
Type of Error Protection	Convolution Coding	Turbo Coding
Coding Rate	1/3	1/3

Static Rate Matching parameter	1.0	1.0
Size of CRC	16	16
Position of TrCH in radio frame	fixed	fixed

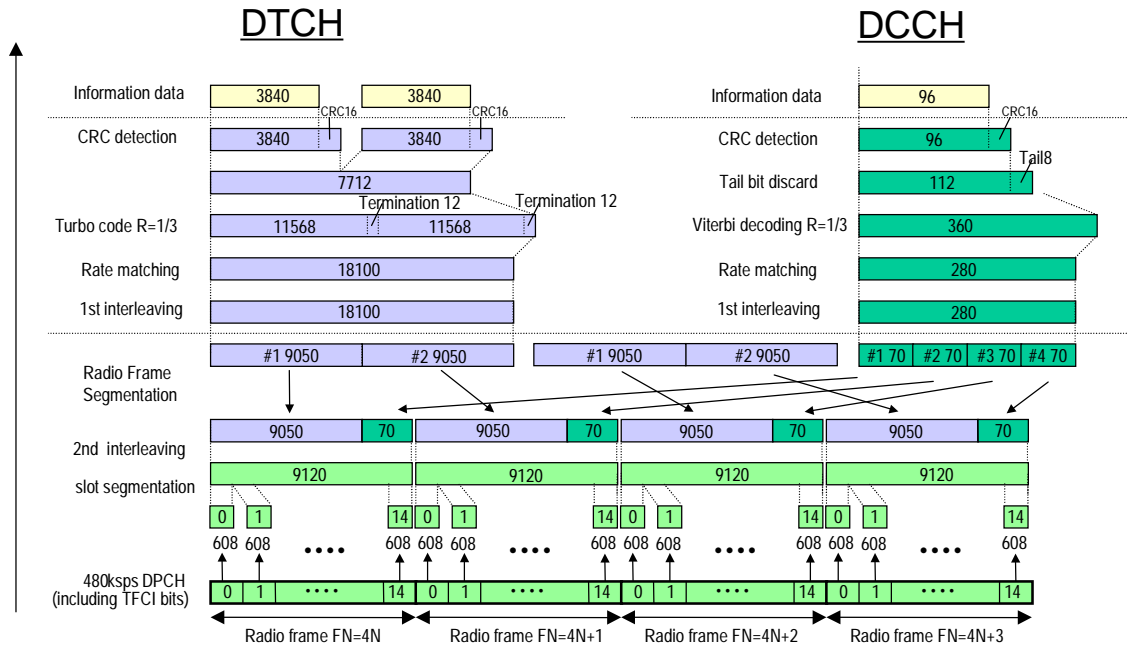

Figure A.8 (Informative): Channel coding of DL reference measurement channel (384 kbps)

A.4 DL reference compressed mode parameters

The following parameters characterise the transmission gap :

TGL : 7

SFN : FFS

SN : FFS

The following parameters characterise the compressed mode pattern :

TGP : FFS

TGL : 7

TGD : FFS

PD: FFS

SFN : FFS

PCM: FFS

Transmission time reduction method FFS

Annex B (normative): Propagation conditions

B.1 General

B.2 Propagation Conditions

B.2.1 Static propagation condition

The propagation for the static performance measurement is an Additive White Gaussian Noise (AWGN) environment. No fading and multi-paths exist for this propagation model.

B.2.2 Multi-path fading propagation conditions

Table B2 shows propagation conditions that are used for the performance measurements in multi-path fading environment. All taps have classical Doppler spectrum.

Table B.2: Propagation Conditions for Multi path Fading Environments

Case 1, speed 3km/h		Case 2, speed 3 km/h		Case 3, 120 km/h		Case 4, 3 km/h	
Relative Delay [ns]	Average Power [dB]	Relative Delay [ns]	Average Power [dB]	Relative Delay [ns]	Average Power [dB]	Relative Delay [ns]	Average Power [dB]
0	0	0	0	0	0	0	0
976	-10	976	0	260	-3	976	0
		[20000]	0	521	-6		
				781	-9		

B.2.3 Moving propagation conditions

The dynamic propagation conditions for the test of the baseband performance are non fading channel models with two taps. The moving propagation condition has two tap, one static, Path0, and one moving, Path1. The time difference between the two paths is according Equation (B.1)

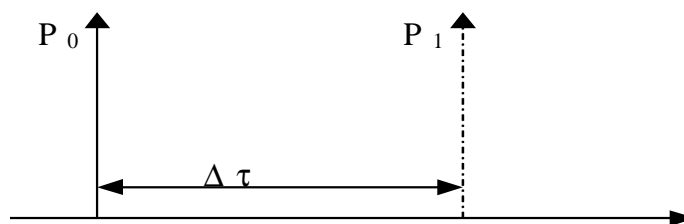

Figure B.1: The moving propagation conditions

$$\Delta\tau = \left(1 + \frac{A}{2} (1 + \sin(\Delta\omega \cdot t)) \right) \mu s \quad \text{Equation B.1}$$

The parameters in the equation are shown in.

A	5 μ s
---	-----------

$\Delta\omega$	$40 \cdot 10^{-3} \text{ s}^{-1}$
----------------	-----------------------------------

B.2.4 Birth-Death propagation conditions

The dynamic propagation conditions for the test of the baseband performance is a non fading propagation channel with two taps. The moving propagation condition has two taps, Path1 and Path2 which alternate between 'birth' and 'death'. The positions the paths appear are randomly selected with an equal probability rate and is shown in Figure B.2.

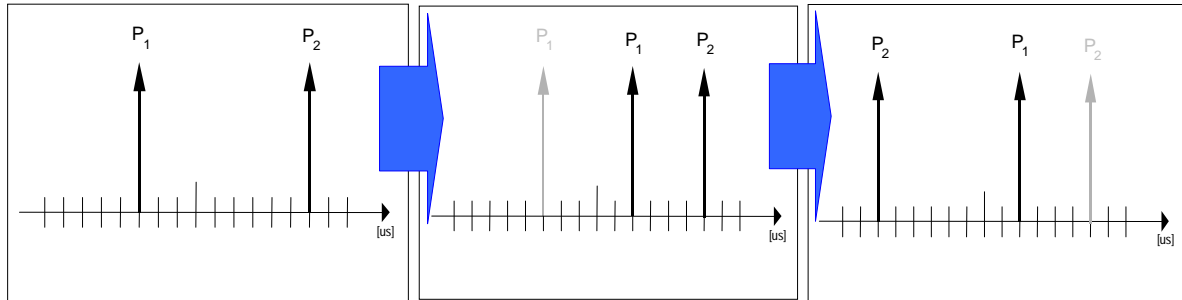

Figure B.2: Birth death propagation sequence

Note

1. Two paths, Path1 and Path2 are randomly selected between $-5\mu\text{s}$ and $+5\mu\text{s}$.
2. After 191 ms, Path1 vanishes and reappears immediately at a new location randomly selected between $-5\mu\text{s}$ and $+5\mu\text{s}$ but excludes the point Path2.
3. After an additional 191 ms, Path2 vanishes and reappears immediately at a new location randomly selected between $-5\mu\text{s}$ and $+5\mu\text{s}$ but excludes the point Path1.
4. The sequence in 2) and 3) is repeated.

Annex C (normative): Downlink Physical Channels

C.1 General

This Normative annex specifies the downlink physical channels that are needed for setting a connection and channels that are needed during a connection.

C.2 Connection Set-up

Table C.2 describes the downlink Physical Channels that are required for connection set up.

Table C.1. Downlink Physical Channels required for connection set-up

Physical Channel
CPICH
PCCPCH
SCH
SCCPCH
PICH
AICH
DPCH

C.3. During connection

The following clauses, describes the downlink Physical Channels that are transmitted during a connection i.e., when measurements are done. For these measurements the offset between DPCH and SCH shall be zero chips at base station meaning that SCH is overlapping with the first symbols in DPCH in the beginning of DPCH slot structure.

C.3.1 Measurement of Rx Characteristics

Table C.3.1 is applicable for measurements on the Receiver Characteristics (Section 7) with the exception of clause 7.4 (Maximum input level)

Table C.2. Downlink Physical Channels transmitted during a connection.

Physical Channel	Power
CPICH	$CPICH_{Ec} / DPCH_{Ec} = 7 \text{ dB}$
PCCPCH	$PCCPCH_{Ec} / DPCH_{Ec} = 5 \text{ dB}$
SCH	$SCH_{Ec} / DPCH_{Ec} = 5 \text{ dB}$
PICH	$PICH_{Ec} / DPCH_{Ec} = 2 \text{ dB}$
DPCH	Test dependent power

C.3.2 Measurement of Performance requirements

Table C.3 is applicable for measurements on the Performance requirements (Section 8), including clause 7.4 (Maximum input level)

Table C.3 Downlink Physical Channels transmitted during a connection.¹

Physical Channel	Power	Note
CPICH	CPICH_Ec/Ior = -10 dB	
PCCPCH	PCCPCH_Ec/Ior = -12 dB	
SCH	SCH_Ec/Ior = -12 dB	This power shall be divided equally between Primary and Secondary Synchronous channels
PICH	PICH_Ec/Ior = -15 dB	
DPCH	Test dependent power	
OCNS	Necessary power so that total transmit power spectral density of BS (Ior) adds to one	

C.3.3 Connection with open-loop transmit diversity mode

Table C.4 is applicable for measurements for clause 8.6.1 (Demodulation of DCH in open loop transmit diversity mode)

Table C.4. Downlink Physical Channels transmitted during a connection.¹

Physical Channel	Power	Note
CPICH (antenna 1)	CPICH_Ec1/Ior = -13 dB	1. Total CPICH_Ec/Ior = -10 dB
CPICH (antenna 2)	CPICH_Ec2/Ior = -13 dB	
PCCPCH (antenna 1)	PCCPCH_Ec1/Ior = -15 dB	1. STTD applied 2. Total PCCPCH_Ec/Ior = -12 dB
PCCPCH (antenna 2)	PCCPCH_Ec2/Ior = -15 dB	
SCH (antenna 1 / 2)	SCH_Ec/Ior = -12 dB	1. TSTD applied. 2. This power shall be divided equally between Primary and Secondary Synchronous channels
PICH (antenna 1)	PICH_Ec1/Ior = -18 dB	1. STTD applied 2. Total PICH_Ec/Ior = -15 dB
PICH (antenna 2)	PICH_Ec2/Ior = -18 dB	
DPCH	Test dependent power	1. STTD applied 2. Total power from both antennas
OCNS	Necessary power so that total transmit power spectral density of BS (Ior) adds to one	1. This power shall be divided equally between antennas

¹ Power levels are based on the assumption that multipath propagation conditions and noise source representing interference from other cells Ioc are turned on after the call set-up phase.

C.3.4 Connection with closed loop transmit diversity mode

Table C.5 is applicable for measurements for clause 8.6.2 (Demodulation of DCH in closed loop transmit diversity mode)

Table C.5. Downlink Physical Channels transmitted during a connection.¹

Physical Channel	Power	Note
CPICH (antenna 1)	CPICH_Ec1/Ior = -13 dB	1. Total CPICH_Ec/Ior = -10 dB
CPICH (antenna 2)	CPICH_Ec2/Ior = -13 dB	
PCCPCH (antenna 1)	PCCPCH_Ec1/Ior = -15 dB	1. STTD applied
PCCPCH (antenna 2)	PCCPCH_Ec2/Ior = -15 dB	1. STTD applied, total PCCPCH_Ec/Ior = -12 dB
SCH (antenna 1 / 2)	SCH_Ec/Ior = -12 dB	1. TSTD applied
PICH (antenna 1)	PICH_Ec1/Ior = -18 dB	2. STTD applied, total PICH_Ec/Ior = -15 dB
PICH (antenna 2)	PICH_Ec2/Ior = -18 dB	
DPCH	Test dependent power	1. Total power from both antennas
OCNS	Necessary power so that total transmit power spectral density of BS (Ior) adds to one	1. This power shall be divided equally between antennas

Annex D (normative): Environmental conditions

D.1 General

This normative annex specifies the environmental requirements of the UE. Within these limits the requirements of this specifications shall be fulfilled.

D.2 Environmental requirements

The requirements in this clause apply to all types of UE(s)

D.2.1 Temperature

The UE shall fulfil all the requirements in the full temperature range of:

Table D.1

+15°C to +35°C	for normal conditions (with relative humidity of 25 % to 75 %)
-10°C to +55°C	for extreme conditions (see IEC publications 68-2-1 and 68-2-2)

Outside this temperature range the UE, if powered on, shall not make ineffective use of the radio frequency spectrum. In no case shall the UE exceed the transmitted levels as defined in S25.101 for extreme operation.

D.2.2 Voltage

The UE shall fulfil all the requirements in the full voltage range, i.e. the voltage range between the extreme voltages.

The manufacturer shall declare the lower and higher extreme voltages and the approximate shutdown voltage. For the equipment that can be operated from one or more of the power sources listed below, the lower extreme voltage shall not be higher, and the higher extreme voltage shall not be lower than that specified below.

Table D.2

Power source	Lower extreme voltage	Higher extreme voltage	Normal conditions voltage
AC mains	0,9 * nominal	1,1 * nominal	nominal
Regulated lead acid battery	0,9 * nominal	1,3 * nominal	1,1 * nominal
Non regulated batteries:			
Leclanché / lithium	0,85 * nominal	Nominal	Nominal
Mercury/nickel & cadmium	0,90 * nominal	Nominal	Nominal

Outside this voltage range the UE if powered on, shall not make ineffective use of the radio frequency spectrum. In no case shall the UE exceed the transmitted levels as defined in S25.101 for extreme operation. In particular, the UE shall inhibit all RF transmissions when the power supply voltage is below the manufacturer declared shutdown voltage.

D.2.3 Vibration

The UE shall fulfil all the requirements when vibrated at the following frequency/amplitudes:

Table D.3

Frequency	ASD (Acceleration Spectral Density) random vibration
5 Hz to 20 Hz	0,96 m ² /s ³
20 Hz to 500 Hz	0,96 m ² /s ³ at 20 Hz, thereafter –3 dB/Octave

Outside the specified frequency range the UE, if powered on, shall not make ineffective use of the radio frequency spectrum. In no case shall the UE exceed the transmitted levels as defined in S25.101 for extreme operation

Annex F (Informative): UE capabilities (FDD)

This section provides the UE capabilities related to 25.101.

Notes:

This section shall be aligned with TR25.926, UE Radio Access Capabilities regarding FDD RF parameters. These RF UE Radio Access capabilities represent options in the UE, that require signalling to the network.

In addition there are options in the UE that do not require any signalling. They are designated as UE baseline capabilities, according to TR 21.904, Terminal Capability Requirements

Table F.1 provides the list of UE radio access capability parameters and possible values for 25.101

Table F.1: RF UE Radio Access Capabilities

Table F.1: RF UE Radio Access Capabilities	UE radio access capability parameter	Value range
FDD RF parameters	UE power class (25.101 section 6.2.1)	3, 4
	Tx/Rx frequency separation for frequency band a) (25.101 section 5.3) Not applicable if UE is not operating in frequency band a)	190 MHz, 174.8-205.2 MHz, 134.8-245.2 MHz

Table F.2 provides the UE baseline implementation capabilities for 25.101

Table F.2: UE RF Baseline Implementation Capabilities

UE implementation capability	Value range
Radio frequency bands (25.101 section 5.2)	a), b), a+b)

Annex G (Informative): Change Request History

Inclusion of CRs approved by TSG-RAN#6.

Doc-1st-	Spec	CR	R	Phas	Subject	Cat	Vers	Versio
RP-99772	25.101	001	2	R99	Correction of UE Measurement Channels Rev.2	F	3.0.0	3.1.0
RP-99772	25.101	003		R99	Modifications for Receiver Characteristics	F	3.0.0	3.1.0
RP-99772	25.101	004		R99	Corrections to Tx Diversity testing assumptions	F	3.0.0	3.1.0
RP-99771	25.101	005		R99	UE DL performance requirements	D	3.0.0	3.1.0
RP-99772	25.101	006	1	R99	Corrections to Annex C Down link Physical	F	3.0.0	3.1.0
RP-99772	25.101	007		R99	Proposal for ACLR/ACS specifications for class	F	3.0.0	3.1.0
RP-99773	25.101	008		R99	Addition of propagation condition to inner and	B	3.0.0	3.1.0
RP-99772	25.101	009		R99	Clarification of Uplink inner loop power control	C	3.0.0	3.1.0
RP-99773	25.101	010		R99	Modifications to demodulation test parameters	B	3.0.0	3.1.0
RP-99772	25.101	011		R99	Power setting of DPCH	C	3.0.0	3.1.0
RP-99771	25.101	012		R99	Editorial changes to 25.101v3.0.0	D	3.0.0	3.1.0
RP-99826	25.101	013		R99	Update of UE RF capabilities	F	3.0.0	3.1.0
RP-99772	25.101	014		R99	Update of ITU Region 2 Specific Specifications	C	3.0.0	3.1.0
RP-99772	25.101	015		R99	Performance requirements for demodulation of	F	3.0.0	3.1.0
RP-99830	25.101	016	1	R99	Change of propagation conditions	F	3.0.0	3.1.0
RP-99772	25.101	017		R99	CR for minimum requirements for UE power	F	3.0.0	3.1.0
RP-99772	25.101	018		R99	Downlink Inner loop power control	C	3.0.0	3.1.0
RP-99773	25.101	019		R99	Performance requirements in downlink	B	3.0.0	3.1.0

History

Document history		
V3.0.0	October 1999	
V3.1.0	December 1999	

CHANGE REQUEST

Please see embedded help file at the bottom of this page for instructions on how to fill in this form correctly.

25.101 CR 023

Current Version: **3.1.0**

GSM (AA.BB) or 3G (AA.BBB) specification number ↑

↑ CR number as allocated by MCC support team

For submission to: **RAN #7**
list expected approval meeting # here ↑

for approval
for information

strategic
non-strategic (for SMG use only)

Form: CR cover sheet, version 2 for 3GPP and SMG The latest version of this form is available from: <ftp://ftp.3gpp.org/Information/CR-Form-v2.doc>

Proposed change affects:

(at least one should be marked with an X)

(U)SIM ME UTRAN / Radio Core Network

Source:

RAN WG4

Date:

29.2.2000

Subject:

Editorial corrections

Work item:

TS 25.101

Category:

(only one category shall be marked with an X)

F Correction
A Corresponds to a correction in an earlier release
B Addition of feature
C Functional modification of feature
D Editorial modification

Release:

Phase 2
Release 96
Release 97
Release 98
Release 99
Release 00

Reason for change:

editorial improvements and corrections are introduced.

Clauses affected:

Other specs affected:

Other 3G core specifications → List of CRs:
Other GSM core specifications → List of CRs:
MS test specifications → List of CRs:
BSS test specifications → List of CRs:
O&M specifications → List of CRs:

Other comments:

CHANGE REQUEST

Please see embedded help file at the bottom of this page for instructions on how to fill in this form correctly.

25.101 CR 020

Current Version: **3.1.0**

GSM (AA.BB) or 3G (AA.BBB) specification number ↑

↑ CR number as allocated by MCC support team

For submission to: **TSG RAN#7**
list expected approval meeting # here ↑

for approval
for information

strategic
non-strategic (for SMG use only)

Form: CR cover sheet, version 2 for 3GPP and SMG The latest version of this form is available from: <ftp://ftp.3gpp.org/Information/CR-Form-v2.doc>

Proposed change affects:
(at least one should be marked with an X)

(U)SIM ME UTRAN / Radio Core Network

Source: RAN WG4

Date: 2000-01-13

Subject: Clarifications to measurement channels

Work item: UTRA

Category:

(only one category shall be marked with an X)

F Correction
A Corresponds to a correction in an earlier release
B Addition of feature
C Functional modification of feature
D Editorial modification

Release:

Phase 2
Release 96
Release 97
Release 98
Release 99
Release 00

Reason for change:

Currently it not clear what Slot Formats are used in measurement channels. Also value for DPCCH power offset relative to DPDCH in downlink is missing from current specification.

Clauses affected: Annex A.2. and A.3

Other specs affected:

Other 3G core specifications → List of CRs:
Other GSM core specifications → List of CRs:
MS test specifications → List of CRs:
BSS test specifications → List of CRs:
O&M specifications → List of CRs:

Other comments:



help.doc

<----- double-click here for help and instructions on how to create a CR.

Annex A (normative): Measurement channels

A.1 General

The measurement channels in this annex are defined to derive the requirements in section 6, 7 and 8. The measurement channels represent example configuration of radio access bearers for different data rates.

The measurement channel for 12.2 kbps shall be supported by any UE both in up- and downlink. Support for other measurement channels is depending on the UE Radio Access capabilities.

A.2 UL reference measurement channel

A.2.1 UL reference measurement channel (12.2 kbps)

The parameters for the 12.2 kbps UL reference measurement channel are specified in Table A.1 and Table A.2. The channel coding for information is shown in figure A.1

Table A.1: UL reference measurement channel physical parameters (12.2 kbps)

Parameter	Unit	Level
Information bit rate	kbps	12.2
DPDCH	kbps	60
DPCCH	kbps	15
<u>DPCCH Slot Format #i</u>	=	<u>0¹</u>
DPCCH/DPDCH	dB	-6
TFCI	-	On
Repetition	%	23

Table A.2: UL reference measurement channel, transport channel parameters (12.2 kbps)

Parameters	DCCH	DTCH
Transport Channel Number	1 (TBD by WG2)	2 (TBD by WG2)
Transport Block Size	96	244
Transport Block Set Size	96	244
Transmission Time Interval	40 ms	20 ms
Type of Error Protection	Convolution Coding	Convolution Coding
Coding Rate	1/3	1/3
Static Rate Matching parameter	1.0	1.0
Size of CRC	16	16
Position of TrCH in radio frame	Fixed	fixed

¹ Slot Format #2 is used for closed loop tests in clause 8.6.2.

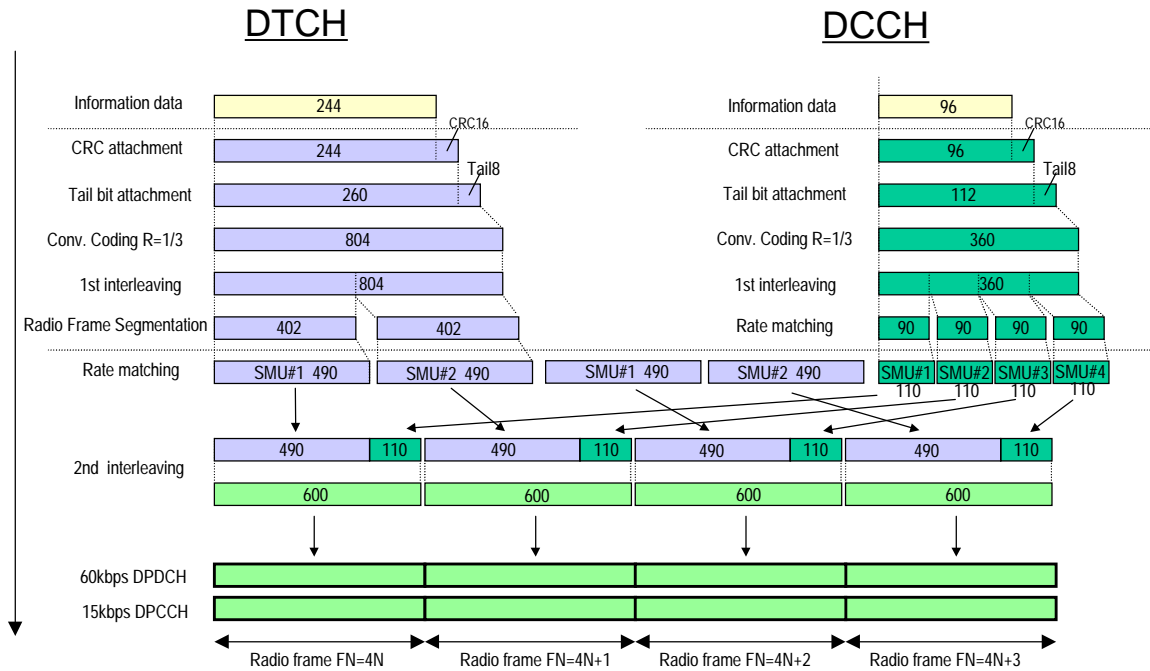

Figure A.1(Informative): Channel coding of UL reference measurement channel (12.2 kbps)

A.2.2 UL reference measurement channel (64 kbps)

The parameters for the 64 kbps UL reference measurement channel are specified in Table A.3 and Table A.4. The channel coding for information is shown in figure A.2. This measurement channel is not currently used in TS25.101 but can be used for future requirements.

Table A.3: UL reference measurement channel (64 kbps)

Parameter	Unit	Level
Information bit rate	kbps	64
DPDCH	kbps	240
DPCCH	kbps	15
DPCCH Slot Format #i	=	0
DPCCH/DPDCH	dB	-9
TFCI	-	On
Repetition	%	18

Table A.4: UL reference measurement channel, transport channel parameters (64kbps)

Parameter	DCCH	DTCH
Transport Channel Number	1 (TBD by WG2)	2 (TBD by WG2)
Transport Block Size	96	1280
Transport Block Set Size	96	1280
Transmission Time Interval	40 ms	20 ms
Type of Error Protection	Convolution Coding	Turbo Coding
Coding Rate	1/3	1/3
Static Rate Matching parameter	1.0	1.0

Size of CRC	16	16
Position of TrCH in radio frame	Fixed	Fixed

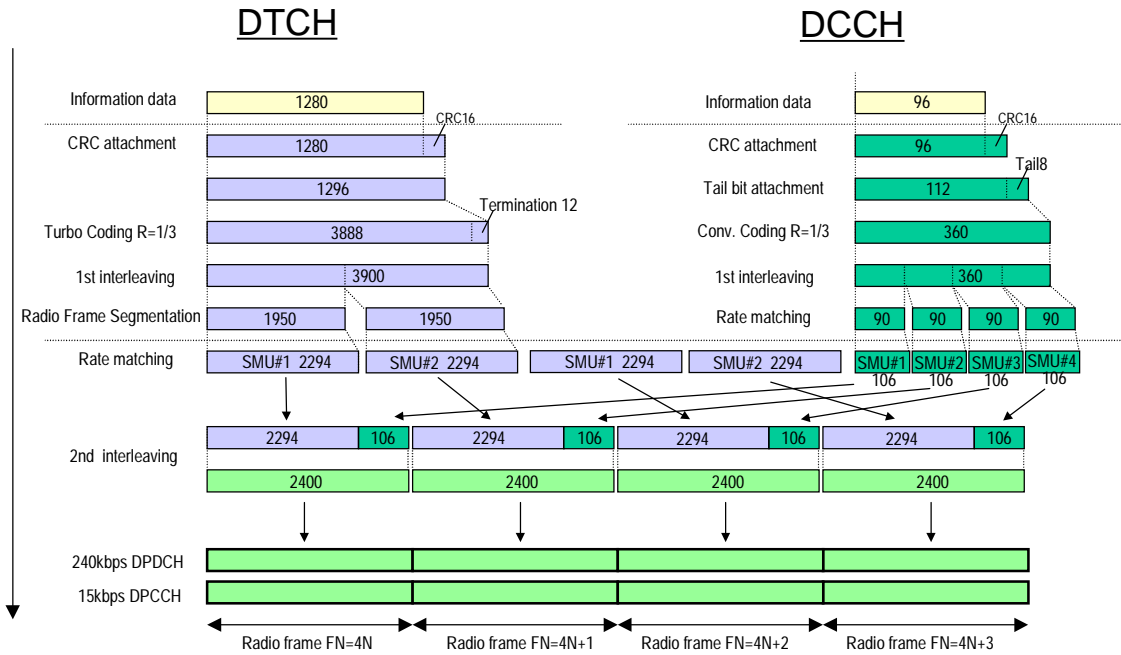

Figure A.2 (Informative): Channel coding of UL reference measurement channel (64 kbps)

A.2.3 UL reference measurement channel (144 kbps)

The parameters for the 144 kbps UL reference measurement channel are specified in Table A.5 and Table A.6. The channel coding for information is shown in Figure A.3. This measurement channel is not currently used in TS25.101 but can be used for future requirements.

Table A.5: UL reference measurement channel (144 kbps)

Parameter	Unit	Level
Information bit rate	kbps	144
DPDCH	kbps	480
DPCCH	kbps	15
DPCCH Slot Format #i	=	0
DPCCH/DPDCH	dB	-12
TFCI	-	On
Repetition	%	8

Table A.6: UL reference measurement channel, transport channel parameters (144kbps)

Parameters	DCCH	DTCH
Transport Channel Number	1 (TBD by WG2)	2 (TBD by WG2)
Transport Block Size	96	2880
Transport Block Set Size	96	2880
Transmission Time Interval	40 ms	20 ms

Type of Error Protection	Convolution Coding	Turbo Coding
Coding Rate	1/3	1/3
Static Rate Matching parameter	1.0	1.0
Size of CRC	16	16
Position of TrCH in radio frame	Fixed	Fixed

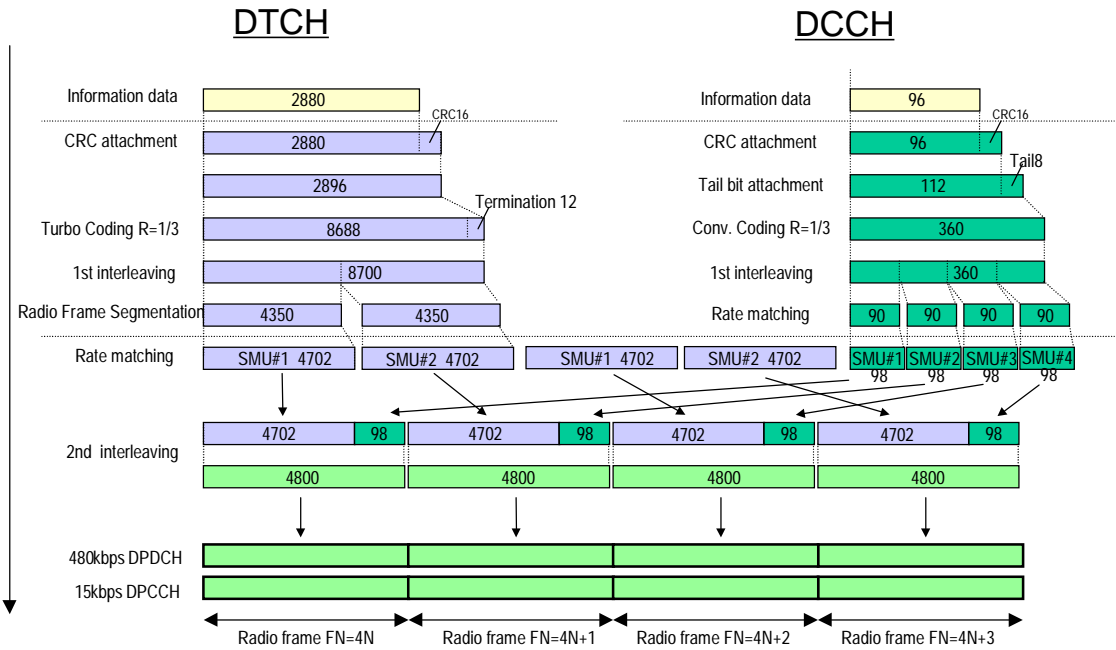

Figure A.3 (Informative): Channel coding of UL reference measurement channel (144 kbps)

A.2.4 UL reference measurement channel (384 kbps)

The parameters for the 384 kbps UL reference measurement channel are specified in Table A.7 and Table A.8. The channel coding for information is shown in Figure A.4. This measurement channel is not currently used in TS25.101 but can be used for future requirements.

Table A.7: UL reference measurement channel (384 kbps)

Parameter	Unit	Level
Information bit rate	kbps	384
DPDCH	kbps	960
DPCCH	kbps	15
DPCCH Slot Format #i	=	0
DPCCH/DPDCH	dB	-12
TFCI	-	On
Puncturing	%	18

Table A.8: UL reference measurement channel, transport channel parameters (384 kbps)

Parameter	DCCH	DTCH
Transport Channel Number	1 (TBD by WG2)	2 (TBD by WG2)
Transport Block Size	96	3840
Transport Block Set Size	96	7680
Transmission Time Interval	40 ms	20 ms
Type of Error Protection	Convolution Coding	Turbo Coding
Coding Rate	1/3	1/3
Static Rate Matching parameter	1.0	1.0
Size of CRC	16	16
Position of TrCH in radio frame	Fixed	Fixed

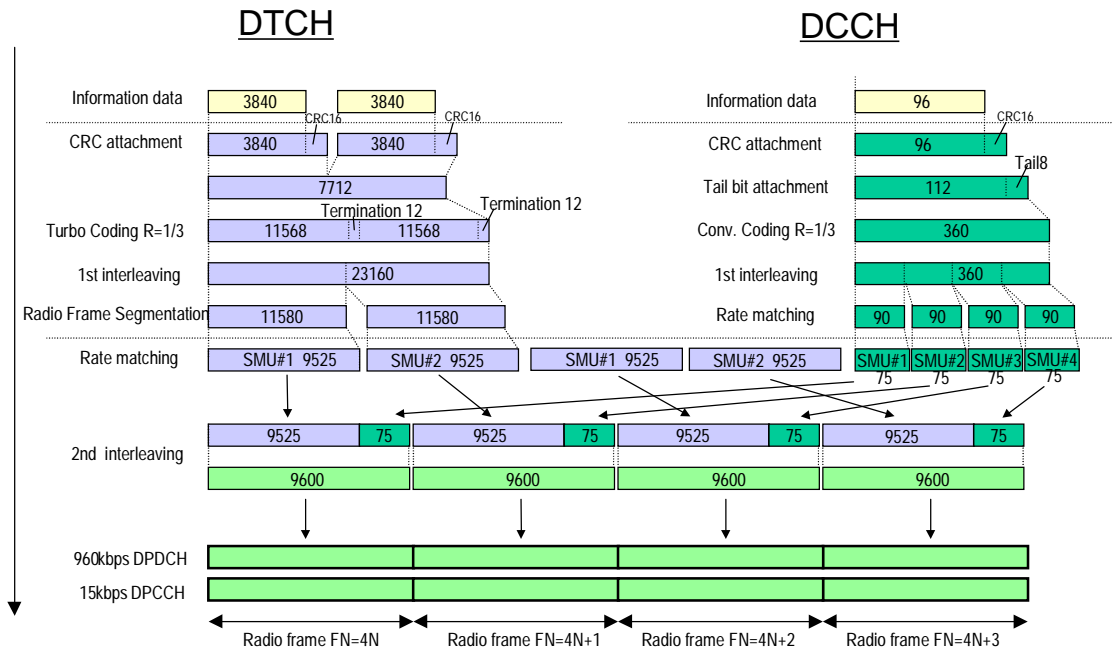

Figure A.4 (Informative): Channel coding of UL reference measurement channel (384 kbps)

A.3 DL reference measurement channel

A.3.1 DL reference measurement channel (12.2 kbps)

The parameters for the 12.2 Kbps DL reference measurement channel are specified in Table A. 9 and Table A.10. The channel coding is shown for information in figure A.5

Table A.9: DL reference measurement channel physical parameters (12.2 kbps)

Parameter	Unit	Level
Information bit rate	kbps	12.2
DPCH	ksp/s	30
Slot Format #i	-	11
TFCI	-	On
Power offsets PO1, PO2 and PO3	dB	0
Puncturing	%	14.5

Table A.10: DL reference measurement channel, transport channel parameters (12.2 kbps)

Parameter	DCCH	DTCH
Transport Channel Number	1 (TBD by WG2)	2 (TBD by WG2)
Transport Block Size	96	244
Transport Block Set Size	96	244
Transmission Time Interval	40 ms	20 ms
Type of Error Protection	Convolution Coding	Convolution Coding
Coding Rate	1/3	1/3
Static Rate Matching parameter	1.0	1.0
Size of CRC	16	16
Position of TrCH in radio frame	fixed	fixed

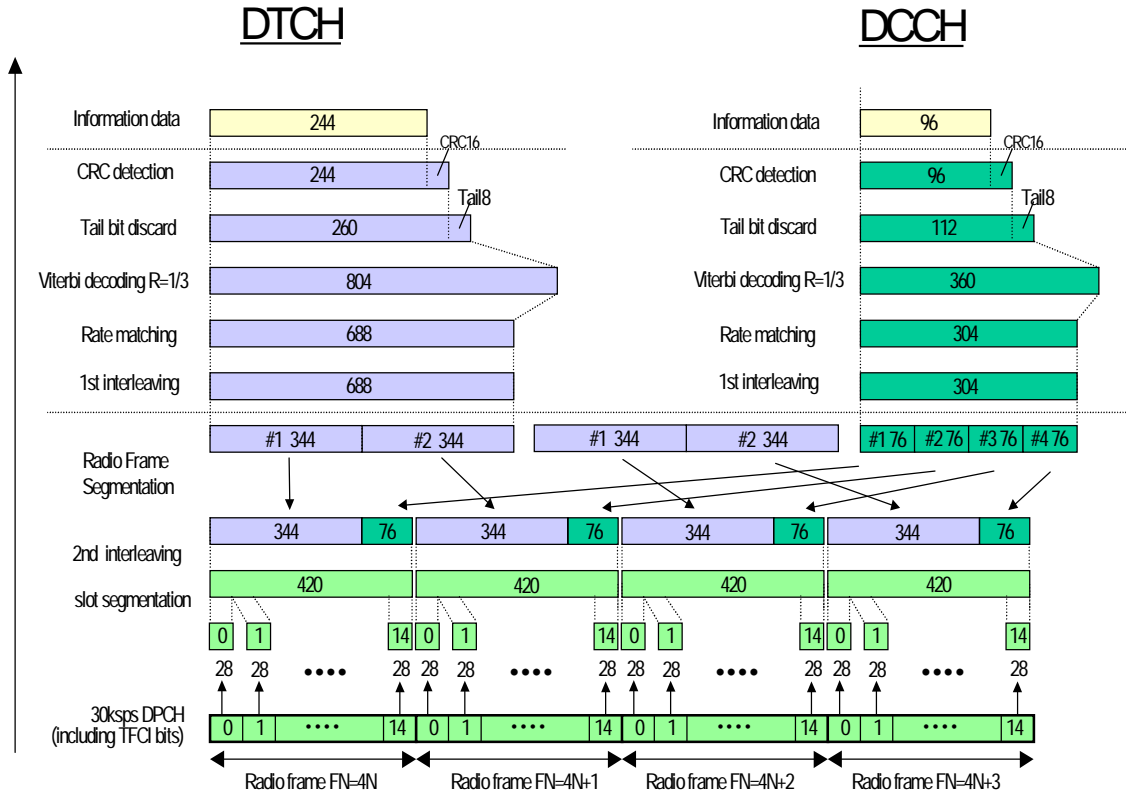

Figure A.5 (Informative): Channel coding of DL reference measurement channel (12.2 kbps)

A.3.2 DL reference measurement channel (64 kbps)

The parameters for the DL reference measurement channel for 64 kbps are specified in Table A.11 and Table A.12. The channel coding is shown for information in Figure A.6

Table A.11: DL reference measurement channel physical parameters (64 kbps)

Parameter	Unit	Level
Information bit rate	kbps	64
DPCH	ksps	120
Slot Format #i	-	13
TFCI	-	On
Power offsets PO1, PO2 and PO3	dB	0
Repetition	%	2.9

Table A.12: DL reference measurement channel, transport channel parameters (64 kbps)

Parameter	DCCH	DTCH
Transport Channel Number	1 (TBD by WG2)	2 (TBD by WG2)
Transport Block Size	96	1280
Transport Block Set Size	96	1280
Transmission Time Interval	40 ms	20 ms
Type of Error Protection	Convolution Coding	Turbo Coding
Coding Rate	1/3	1/3

Static Rate Matching parameter	1.0	1.0
Size of CRC	16	16
Position of TrCH in radio frame	fixed	fixed

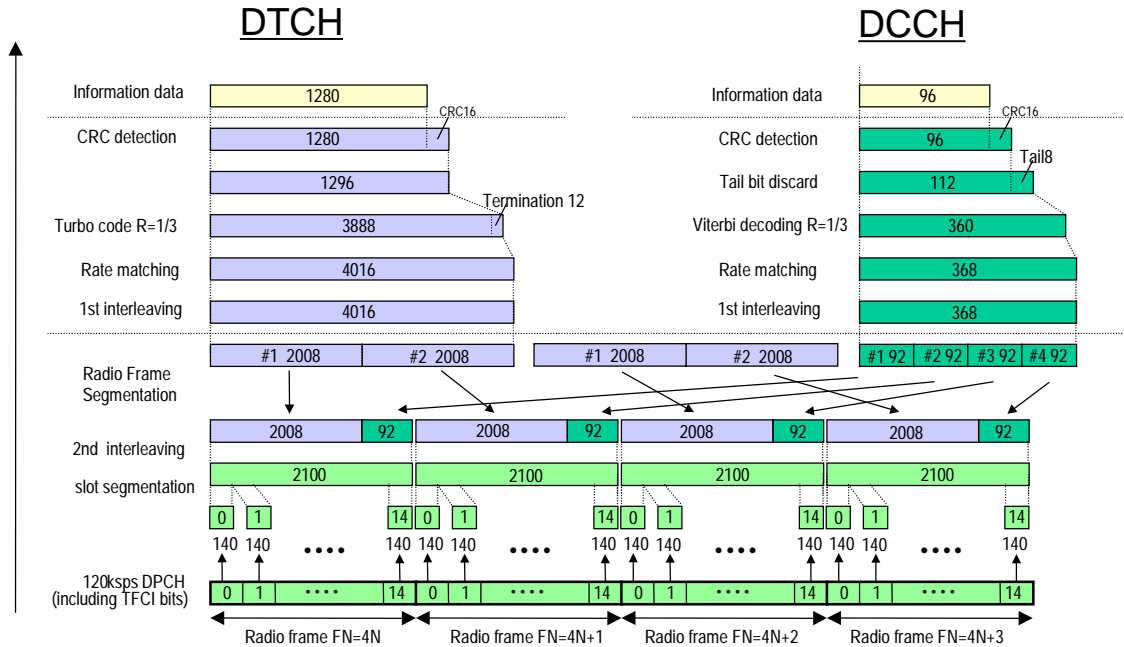

Figure A.6 (Informative): Channel coding of DL reference measurement channel (64 kbps)

A.3.3 DL reference measurement channel (144 kbps)

The parameters for the DL measurement channel for 144 kbps are specified in Table A.13 and Table A.14. The channel coding is shown for information in Figure A.7

Table A.13: DL reference measurement channel physical parameters (144 kbps)

Parameter	Unit	Level
Information bit rate	kbps	144
DPCH	ksps	240
Slot Format #i	=	14
TFCI	-	On
Power offsets PO1, PO2 and PO3	dB	0
Puncturing	%	2.7

Table A.14: DL reference measurement channel, transport channel parameters (144 kbps)

Parameter	DCCH	DTCH
Transport Channel Number	1 (TBD by WG2)	2 (TBD by WG2)
Transport Block Size	96	2880

Transport Block Set Size	96	2880
Transmission Time Interval	40 ms	20 ms
Type of Error Protection	Convolution Coding	Turbo Coding
Coding Rate	1/3	1/3
Static Rate Matching parameter	1.0	1.0
Size of CRC	16	16
Position of TrCH in radio frame	fixed	fixed

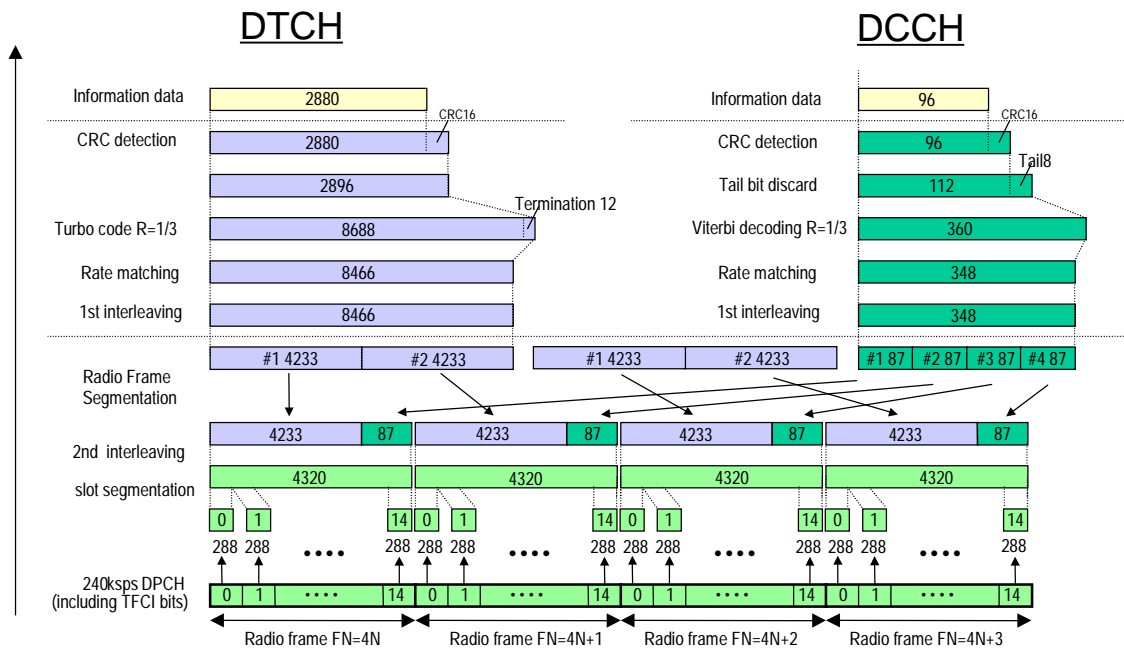

Figure A.7 (Informative): Channel coding of DL reference measurement channel (144 kbps)

A.3.4 DL reference measurement channel (384 kbps)

The parameters for the DL measurement channel for 384 kbps are specified in Table A.15 and Table A.16. The channel coding is shown for information in Figure A.8

Table A.15: DL reference measurement channel, physical parameters (384 kbps)

Parameter	Unit	Level
Information bit rate	kbps	384
DPCH	ksps	480
Slot Format #i	=	15
TFCI		On
Power offsets PO1, PO2 and PO3	dB	0
Puncturing	%	22

Table A.16: DL reference measurement channel, transport channel parameters (384 kbps)

Parameter	DCCH	DTCH

Transport Channel Number	1 (TBD by WG2)	2 (TBD by WG2)
Transport Block Size	96	3840
Transport Block Set Size	96	7680
Transmission Time Interval	40 ms	20 ms
Type of Error Protection	Convolution Coding	Turbo Coding
Coding Rate	1/3	1/3
Static Rate Matching parameter	1.0	1.0
Size of CRC	16	16
Position of TrCH in radio frame	fixed	fixed

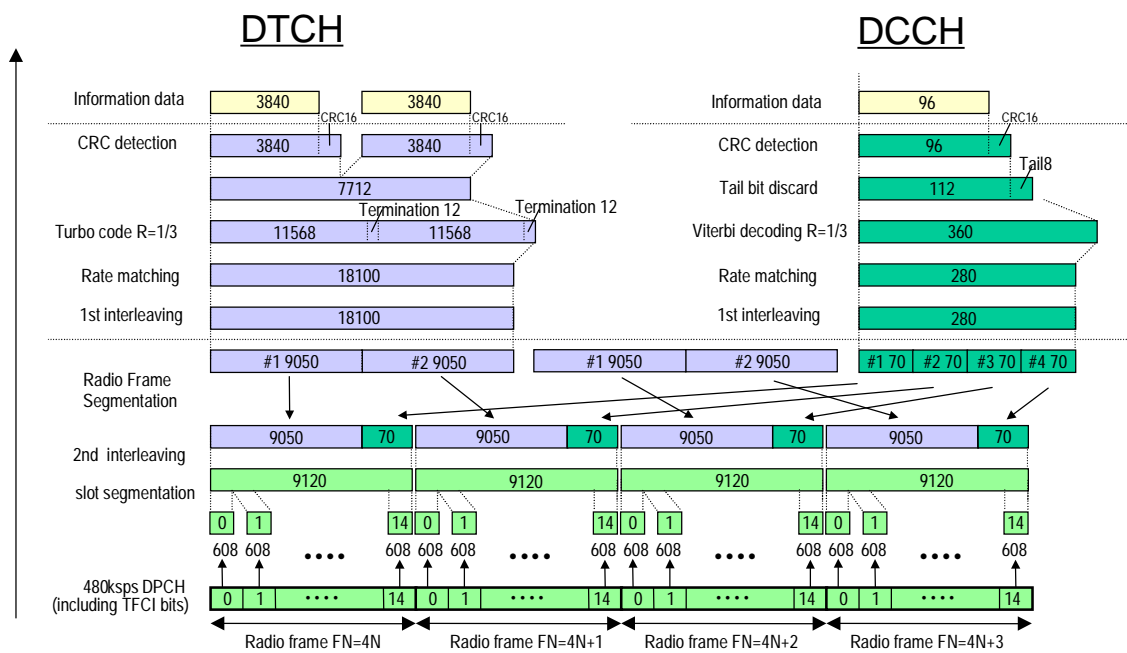

Figure A.8 (Informative): Channel coding of DL reference measurement channel (384 kbps)

A.4 DL reference compressed mode parameters

The following parameters characterise the transmission gap :

TGL : 7

SFN : FFS

SN : FFS

The following parameters characterise the compressed mode pattern :

TGP : FFS

TGL : 7

TGD : FFS

PD: FFS

SFN : FFS

PCM: FFS

Transmission time reduction method FFS

CHANGE REQUEST

Please see embedded help file at the bottom of this page for instructions on how to fill in this form correctly.

25.101 CR 021

Current Version: **3.1.0**

GSM (AA.BB) or 3G (AA.BBB) specification number ↑

↑ CR number as allocated by MCC support team

For submission to: **TSG RAN#7**
list expected approval meeting # here ↑

for approval
for information

strategic
non-strategic (for SMG use only)

Form: CR cover sheet, version 2 for 3GPP and SMG The latest version of this form is available from: <ftp://ftp.3gpp.org/Information/CR-Form-v2.doc>

Proposed change affects:

(at least one should be marked with an X)

(U)SIM ME UTRAN / Radio Core Network

Source:

RAN WG4

Date:

2000-01-21

Subject:

Power measurement definitions for wanted signal (in-channel signal)

Work item:

UTRA

Category:

(only one category shall be marked with an X)

F Correction
A Corresponds to a correction in an earlier release
B Addition of feature
C Functional modification of feature
D Editorial modification

Release:

Phase 2
Release 96
Release 97
Release 98
Release 99
Release 00

Reason for change:

To avoid ambiguity and inconsistency of test conditions and measurement definitions in wanted signal measurement.

Clauses affected:

6.4.1, 6.4.2, 6.4.3, 6.5.1, 6.5.2, 6.5.3, 6.5.4

Other specs affected:

Other 3G core specifications → List of CRs:
Other GSM core specifications → List of CRs:
MS test specifications → List of CRs:
BSS test specifications → List of CRs:
O&M specifications → List of CRs:

Other comments:



help.doc

<----- double-click here for help and instructions on how to create a CR.

6.4 Output power dynamics

Power control is used to limit the interference level

6.4.1 Open loop power control

Open loop power control is the ability of the UE transmitter to sets its output power to a specific value.

6.4.1.1 minimum requirement

The UE open loop power is defined as the average power in a timeslot or ON power duration, whichever is available, and they are measured with a filter that has a Root-Raised Cosine (RRC) filter response with a roll off $\alpha = 0.22$ and a bandwidth equal to the chip rate.

The UE open loop power control tolerance is given in Table 4.

Table 4: Open loop power control

Normal conditions	± 9 dB
Extreme conditions	± 12 dB

6.4.2 Inner loop power control in the uplink

Inner loop power control in the Uplink is the ability of the UE transmitter to adjust its output power in accordance with one or more TPC commands received in the downlink.

6.4.2.1 Power control steps

The power control step is the change in the UE transmitter output power in response to a single TPC command, TPC_cmd, derived at the UE.

6.4.2.1.1 Minimum requirement

The UE transmitter shall have the capability of changing the output power with a step size of 1, 2 and 3 dB according to the value of Δ_{TPC} or $\Delta_{\text{RP-TPC}}$, in the slot immediately after the TPC_cmd can be derived

- (a) The transmitter output power step due to inner loop power control shall be within the range shown in Table 5.
- (b) The transmitter average output power step due to inner loop power control shall be within the range shown in Table 6

The inner loop power is defined as the relative power differences between averaged power of original (reference) timeslot and averaged power of the target timeslot without transient duration. (Figure. 1a and 1b) They are measured with a filter that has a Root-Raised Cosine (RRC) filter response with a roll off $\alpha = 0.22$ and a bandwidth equal to the chip rate.

Table 5: Transmitter power control range

TPC_cmd	Transmitter power control range					
	1 dB step size		2 dB step size		3 dB step size	
	Lower	Upper	Lower	Upper	Lower	Upper
+1	+0.5 dB	+1.5 dB	+1 dB	+3 dB	+1.5 dB	+4.5 dB
0	-0.5 dB	+0.5 dB	-0.5 dB	+0.5 dB	-0.5 dB	+0.5 dB
-1	-0.5 dB	-1.5 dB	-1 dB	-3 dB	-1.5 dB	-4.5 dB

Table 6: Transmitter average power control range

TPC_cmd	Transmitter power control range after 10 equal TPC_cmd					
	1 dB step size		2 dB step size		3 dB step size	
	Lower	Upper	Lower	Upper	Lower	Upper
+1	+8 dB	+12 dB	+16 dB	+24 dB	+24 dB	+36 dB
0	-2 dB	+2 dB	-2 dB	+2 dB	-2 dB	+2 dB
-1	-8 dB	-12 dB	-16 dB	-24 dB	-24 dB	-36 dB

6.4.3 Minimum transmit output power

The minimum controlled output power of the UE is when the power control setting is set to a minimum value. This is when both the inner loop and open loop power control indicate a minimum transmit output power is required.

6.4.3.1 Minimum requirement

The minimum transmit power is defined as an averaged power in a time slot measured with a filter that has a Root-Raised Cosine (RRC) filter response with a roll off $\alpha = 0.22$ and a bandwidth equal to the chip rate. The minimum transmit power shall be better than -44 dBm ~~measured with a filter that has a Root-Raised Cosine (RRC) filter response with a roll off $\alpha = 0.22$ and a bandwidth equal to the chip rate.~~

6.5 Transmit ON/OFF power

6.5.1 Transmit OFF power

The transmit OFF power state is when the UE does not transmit except during UL DTX mode. This parameter is defined as the maximum output transmit power within the channel bandwidth when the transmitter is OFF.

6.5.1.1 Minimum requirement

The transmit OFF power is defined as an averaged power at least in a timeslot duration measured with a filter that has a Root-Raised Cosine (RRC) filter response with a roll off $\alpha = 0.22$ and a

bandwidth equal to the chip rate. The requirement for the transmit OFF power shall be better than -50 dBm, measured with a filter that has a Root-Raised Cosine (RRC) filter response with a roll off $\alpha = 0.22$ and a bandwidth equal to the chip rate

6.5.2 Transmit ON/OFF Time mask

The time mask for transmit ON/OFF defines the ramping time allowed for the UE between transmit OFF power and transmit ON power. Possible ON/OFF scenarios are RACH or UL slotted mode

6.5.2.1 Minimum requirement

The transmit power levels versus time should meet the mask specified in figure 1a, and the signal is measured with a filter that has a Root-Raised Cosine (RRC) filter response with a roll off $\alpha = 0.22$ and a bandwidth equal to the chip rate.

On power is defined as either case as follows. The specification depends on each possible case.

- First preamble of RACH: Open loop accuracy (6.4.1)
- During preamble ramping of the RACH and compressed mode: Accuracy depending on size of the power step.(6.5.3)
- Power step to Maximum Power: Maximum power accuracy (6.2.1)

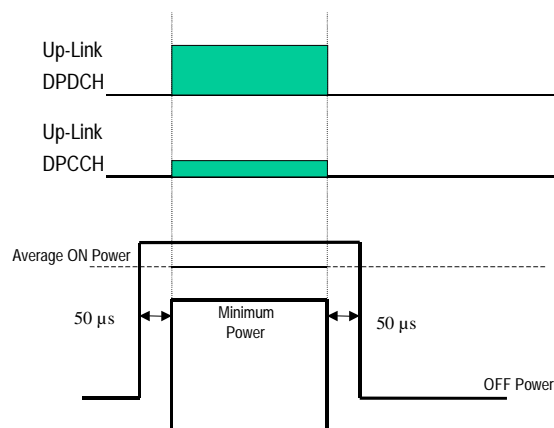

Figure 1a: Transmit ON/OFF template

6.5.3 Change of TFC

A change of TFC (Transport Format Combination) in uplink means that the power in the uplink varies according to the change in data rate. DTX, where the DPCH is turned off, is a special case of variable data, which is used to minimise the interference between UE(s) by reducing the UE transmit power when voice, user or control information is not present.

6.5.3.1 Minimum requirement

A change of output power is required when the TFC, and thereby the data rate, is changed. The ratio of the amplitude between the DPDCH codes and the DPCCH code will vary. The power step due to a change in TFC shall be calculated in the UE so that the power transmitted on the DPCCH shall follow the inner loop power control. The power step shall then be rounded to the closest integer dB value. The accuracy of the power step, given the step size is specified in Table 6b. The power change by TFC is defined as the relative power differences between the averaged power of original (reference) timeslot and the averaged power of target timeslot without transient duration. And they are measured with a filter that has a Root-Raised Cosine (RRC) filter response with a roll off $\alpha = 0.22$ and a bandwidth equal to the chip rate.

Table 6b: Transmitter power step tolerance

Power control step size (Up or down) ΔP [dB]	Transmitter power step tolerance [dB]
1	+/- 0.5 dB
2	+/- 1.0 dB
3	+/- 1.5 dB
$4 \leq \Delta P \leq 10$	+/- 2 dB
$11 \leq \Delta P \leq 15$	+/- 3 dB
$16 \leq \Delta P \leq 20$	+/- 4 dB
$21 \leq \Delta P$	+/- 6 dB

The transmit power levels versus time should meet the mask specified in figure 1a. When power increases the power step shall be performed before the frame boundary, when power decreases the power step shall be performed after the frame boundary.

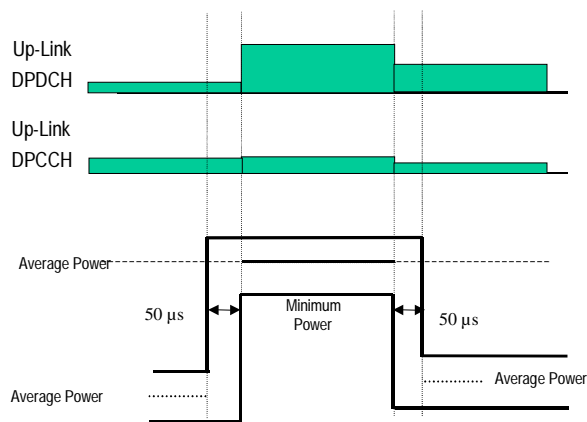

Figure 1b Transmit template during TFC change

6.5.4 Power setting in uplink compressed mode

Compressed mode in uplink means that the power in uplink is changed.

6.5.4.1 Minimum requirement

A change of output power is required during uplink compressed frames since the transmission of data is performed in a shorter interval. The ratio of the amplitude between the DPDCH codes and the DPCCH code will also vary. The power step due to compressed mode shall be calculated in the UE so that the energy transmitted on the pilot bits during each transmitted slot shall follow the inner loop power control. Thereby the power step during the transmitted part of a compressed frame shall be such that the power on the DPCCH follows the inner loop power control with an additional power offset during a compressed frame of $N_{pilot,N} / N_{pilot,C}$ where $N_{pilot,C}$ is the number of pilot bits per slot when in compressed mode, and $N_{pilot,N}$ is the number of pilot bits per slot in normal mode.

The power step shall then be rounded to the closest integer dB value. The accuracy of the power step, given the step size is specified in Table 6b in paragraph 6.5.3.1. The power step is defined as the relative power differences between the average power of original (reference) timeslot and the averaged power of target timeslot. During the compress mode, the average should be done in only either power ON duration. The relative power is measured with a filter that has a Root-Raised Cosine (RRC) filter response with a roll off $\alpha = 0.22$ and a bandwidth equal to the chip rate.

The transmit power levels versus time shall meet the mask specified in figure 2. When power increases the power step shall be performed before the actual slot boundary, when power decreases the power step shall be performed after the actual slot boundary.

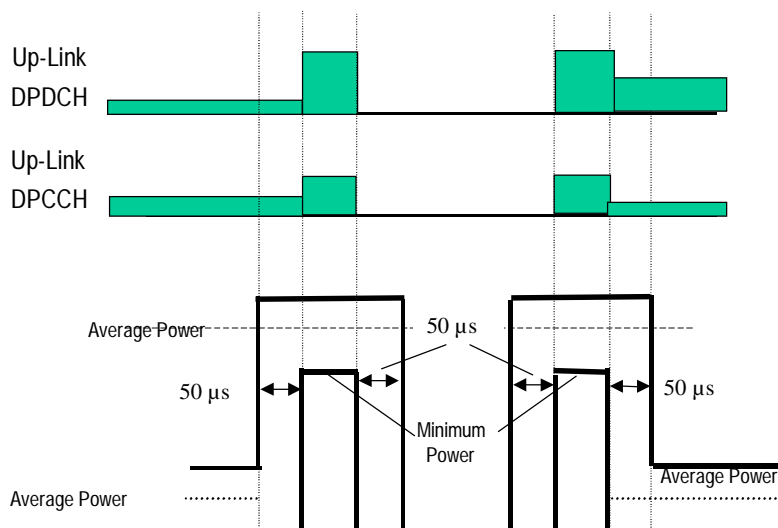

Figure 2 Transmit template during Compressed mode.

Appendix:

(For your information)

TSG-RAN Working Group 4 (Radio) meeting #8
Sophia Antipolis, France, 26–29 October 1999

TSG R4#8 (99)683

Agenda Item: 8.2

Source: Ericsson

Title: Clarification of Transmit On/Off Time mask specification

Document for: Approval

1. Introduction

Some questions have been raised how to interpret the Transmit On/Off Time mask specification in 25.101, especially by T1-RF for the purpose of testing.

2. Clarification

There are a number of different cases when the Transmit On/Off Time mask applies, and in each of these cases the power levels and tolerance for these levels are defined by appropriate parts in the specifications of TS 25.101 v3.0.0.

- First preamble of RACH: Open loop accuracy (6.4.1)
- During preamble ramping of the RACH and compressed mode: Accuracy depending on size of the power step [1]
- Power step to Maximum Power: Maximum power accuracy (6.2.1)

Redefinition or multiple specification of the same requirements should be avoided, so current specification of Transmit On/Off Time Mask is sufficient to our understanding.

For the purpose of testing, it is proposed to take one case, the power step to Maximum Power. This should represent the worst-case.

References

- [1] R4-99682, Power setting of PDCH while varying the data rate, Ericsson.

CHANGE REQUEST

Please see embedded help file at the bottom of this page for instructions on how to fill in this form correctly.

25.101 CR 022

Current Version: **3.1.0**

GSM (AA.BB) or 3G (AA.BBB) specification number ↑

↑ CR number as allocated by MCC support team

For submission to: **RAN#7**

list expected approval meeting # here

↑

for approval
for information

strategic
non-strategic (for SMG use only)

Form: CR cover sheet, version 2 for 3GPP and SMG The latest version of this form is available from: ftp://ftp.3gpp.org/Information/CR-Form-v2.doc

Proposed change affects:

(at least one should be marked with an X)

(U)SIM ME UTRAN / Radio Core Network

Source:

RAN WG4

Date:

2000-01-20

Subject:

Change of propagation conditions for Case 2

Work item:

UTRA

Category:

(only one category shall be marked With an X)

F Correction
A Corresponds to a correction in an earlier release
B Addition of feature
C Functional modification of feature
D Editorial modification

Release:

Phase 2
Release 96
Release 97
Release 98
Release 99
Release 00

Reason for change:

Finalise propagation conditions for the FDD mode.

Clauses affected:

Annex B

Other specs

Affected:

Other 3G core specifications → List of CRs:
Other GSM core specifications → List of CRs:
MS test specifications → List of CRs:
BSS test specifications → List of CRs:
O&M specifications → List of CRs:

Other

comments:

Annex B (normative): Propagation conditions

B.1 General

B.2 Propagation Conditions

B.2.1 Static propagation condition

The propagation for the static performance measurement is an Additive White Gaussian Noise (AWGN) environment. No fading and multi-paths exist for this propagation model.

B.2.2 Multi-path fading propagation conditions

Table B2 shows propagation conditions that are used for the performance measurements in multi-path fading environment. All taps have classical Doppler spectrum.

Table B2: Propagation Conditions for Multi path Fading Environments

Case 1, speed 3km/h		Case 2, speed 3 km/h		Case 3, 120 km/h		Case 4, 15 km/h	
Relative Delay [ns]	Average Power [dB]	Relative Delay [ns]	Average Power [dB]	Relative Delay [ns]	Average Power [dB]	Relative Delay [ns]	Average Power [dB]
0	0	0	0	0	0	0	0
976	-10	976	0	260	-3	976	0
		{20000}	0	521	-6		
				781	-9		

CHANGE REQUEST

Please see embedded help file at the bottom of this page for instructions on how to fill in this form correctly.

25.101 CR 024

Current Version: **3.1.0**

GSM (AA.BB) or 3G (AA.BBB) specification number ↑

↑ CR number as allocated by MCC support team

For submission to: **RAN#7**

list expected approval meeting # here ↑

for approval
for information

strategic
non-strategic (for SMG use only)

Form: CR cover sheet, version 2 for 3GPP and SMG The latest version of this form is available from: <ftp://ftp.3gpp.org/Information/CR-Form-v2.doc>

Proposed change affects:

(at least one should be marked with an X)

(U)SIM ME UTRAN / Radio Core Network

Source:

RAN WG4

Date:

2000-02-24

Subject:

**Birth-Death tap delays
Tap strengths for Birth-Death and Moving propagation conditions**

Work item:

Category:

(only one category
Shall be marked
With an X)

F Correction
A Corresponds to a correction in an earlier release
B Addition of feature
C Functional modification of feature
D Editorial modification

Release:

Phase 2
Release 96
Release 97
Release 98
Release 99
Release 00

Reason for change:

Finalise propagation conditions for the FDD mode.

Clauses affected:

Annex B

Other specs Affected:

Other 3G core specifications → List of CRs:
Other GSM core specifications → List of CRs:
MS test specifications → List of CRs:
BSS test specifications → List of CRs:
O&M specifications → List of CRs:

Other comments:

Annex B (normative): Propagation conditions

B.1 General

B.2 Propagation Conditions

B.2.3 Moving propagation conditions

The dynamic propagation conditions for the test of the baseband performance are non fading channel models with two taps. The moving propagation condition has two tap, one static, Path0, and one moving, Path1. The time difference between the two paths is according Equation (B.1). The taps have equal strengths and equal phases.

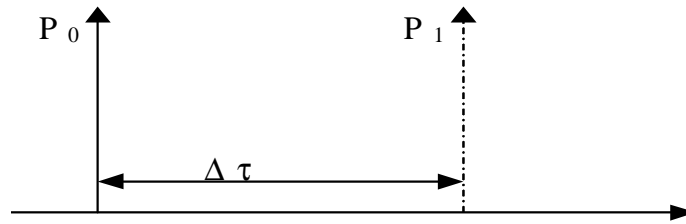

Figure B1: The moving propagation conditions

$$\Delta\tau = \left(1 + \frac{A}{2} (1 + \sin(\Delta\omega \cdot t)) \right) \mu s \quad \text{Equation B.1}$$

The parameters in the equation are shown in.

A	5 μs
Δω	40*10 ⁻³ s ⁻¹

B.2.4 Birth-Death propagation conditions

The dynamic propagation conditions for the test of the baseband performance is a non fading propagation channel with two taps. The moving propagation condition has two taps, Path1 and Path2 which alternate between 'birth' and 'death'. The positions the paths appear are randomly selected with an equal probability rate and is shown in Figure B2.

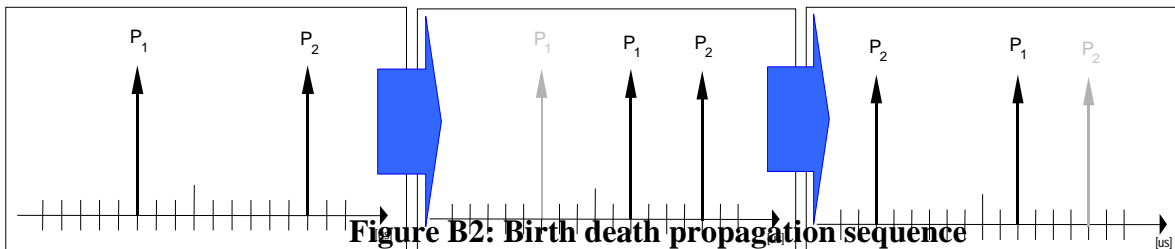

Note

- Two paths, Path1 and Path2 are randomly selected between $-5\mu s$ and $+5\mu s$ from the group $[-5, -4, -3, -2, -1, 0, 1, 2, 3, 4, 5] \mu s$. The paths have equal strengths and equal phases.
- After 191 ms, Path1 vanishes and reappears immediately at a new location randomly selected between $-5\mu s$ and $+5\mu s$ from from the group $[-5, -4, -3, -2, -1, 0, 1, 2, 3, 4, 5] \mu s$ but excludes the point Path2.

3. After an additional 191 ms, Path2 vanishes and reappears immediately at a new location randomly selected ~~between $-5\mu\text{s}$ and $+5\mu\text{s}$~~ from the group $[-5, -4, -3, -2, -1, 0, 1, 2, 3, 4, 5]$ μs but excludes the point Path1.
4. The sequence in 2) and 3) is repeated.

3G CHANGE REQUEST

Please see embedded help file at the bottom of this page for instructions on how to fill in this form correctly.

25.101 CR 025

Current Version: **3.1.0**

3G specification number ↑

↑ CR number as allocated by 3G support team

For submission to TSG **RAN #7** for approval (only one box should
list TSG meeting no. here ↑ for information be marked with an X)

Form: 3G CR cover sheet, version 1.0 The latest version of this form is available from: ftp://ftp.3gpp.org/Information/3GCRF-xx.rtf

Proposed change affects:
(at least one should be marked with an X)

USIM

ME

UTRAN

Core Network

Source: RAN WG4

Date: 2000-02-22

Subject: Out-of-synchronisation handling of the UE in TS 25.101

3G Work item:

Category:

(only one category shall be marked with an X)

- F Correction
- A Corresponds to a correction in a 2G specification
- B Addition of feature
- C Functional modification of feature
- D Editorial modification

X

Reason for change:

Out-of-synchronisation handling for the UE is specified in TS 25.133. The thresholds stated there for shutting the UE power off and on are implicitly defined by this test which is proposed for TS 25.101.

Clauses affected: 6.4

Other specs

Other 3G core specifications

X

→ List of CRs: CR 25.214-066 in R1-000248
CR 25.133-xxx in R4-000142
CR 25.433-xxx in R3-000478
CR 25.423-xxx in R3-000479

affected:

Other 2G core specifications
MS test specifications
BSS test specifications
O&M specifications

X

→ List of CRs:
→ List of CRs:
→ List of CRs:
→ List of CRs:

Other comments:

6.4.X Out-of-synchronisation handling of output power

The UE shall monitor the DPCCH quality in order to detect a loss of the signal on Layer 1, as specified in TS 25.214. The thresholds Q_{out} and Q_{in} specify at what DPCCH quality levels the UE shall shut its power off and when it may turn its transmitter on respectively. The thresholds are not defined explicitly, but are defined by the conditions under which the UE shall shut its transmitter off and turn it on, as stated in this clause.

6.4.X.1 Requirement

The parameters in Table xx are defined using the DL reference measurement channel (12.2) kbps specified in Annex A.3.1 and with static propagation conditions.

Table xx: DCH parameters for test of Out-of-synch handling

<u>Parameter</u>	<u>Unit</u>	<u>Value</u>
\hat{I}_{or}/I_{oc}	dB	-1
I_{oc}	dBm/3.84 MHz	-60
$\frac{DPDCH - E_c}{I_{or}}$	dB	See figure yy: Before point A -16.6 After point A Not defined
$\frac{DPCCH - E_c}{I_{or}}$	dB	See figure yy
<u>Information Data Rate</u>	kbps	12.2
<u>TFCI</u>	=	on

The conditions for when the UE shall shut its transmitter on and when it may turn it on are defined by the parameters in Table xx together with the DPCH power level as defined in Figure yy.

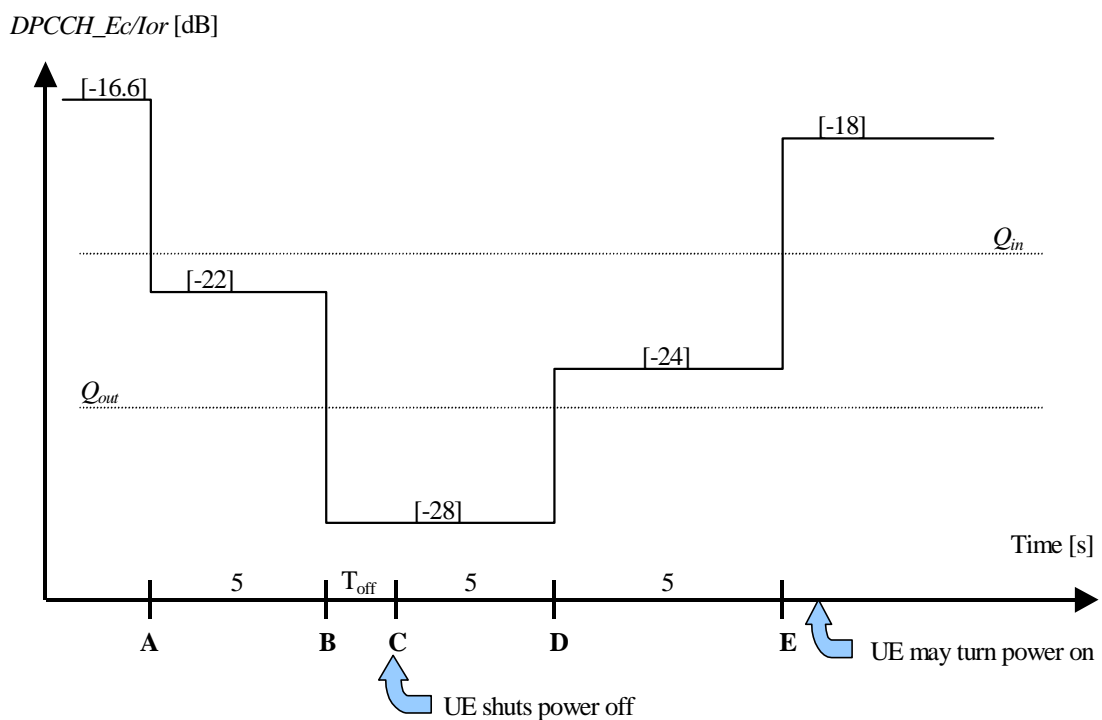

Figure yy. Conditions for out-of-synch handling in the UE. The indicated thresholds Q_{out} and Q_{in} are only informative.

The requirements for the UE are that

1. The UE shall not shut its transmitter off before point B.
2. The UE shall shut its transmitter off before point C, which is $T_{off} = [200]$ ms after point B
3. The UE shall not turn its transmitter on between points C and E.
4. The UE may turn its transmitter on after point E.

CHANGE REQUEST

Please see embedded help file at the bottom of this page for instructions on how to fill in this form correctly.

25.101 CR 026

Current Version: **3.1.0**

GSM (AA.BB) or 3G (AA.BBB) specification number ↑

↑ CR number as allocated by MCC support team

For submission to: **TSG RAN #7**
list expected approval meeting # here ↑

For approval for information

strategic non-strategic (for SMG use only)

Form: CR cover sheet, version 2 for 3GPP and SMG The latest version of this form is available from: <ftp://ftp.3gpp.org/Information/CR-Form-v2.doc>

Proposed change affects: (U)SIM ME UTRAN / Radio Core Network
(at least one should be marked with an X)

Source: RAN WG4 **Date:** 2000-01-18

Subject: UE Modulation performance requirements

Work item: UTRA

Category: F Correction **Release:** Phase 2
A Corresponds to a correction in an earlier release Release 96
(only one category shall be marked with an X) B Addition of feature Release 97
C Functional modification of feature Release 98
D Editorial modification Release 99
Release 00

Reason for change: Requirements for peak code domain error are missing. Applicable power levels are clarified for EMV and PCDE.

Clauses affected: 6.8

Other specs affected: Other 3G core specifications → List of CRs:
Other GSM core specifications → List of CRs:
MS test specifications → List of CRs:
BSS test specifications → List of CRs:
O&M specifications → List of CRs:

Other comments: Based on discussions in RAN4, Update of CR proposed in R4-000050.

6.8 Transmit modulation

6.8.1 Transmit pulse shape filter

The transmit pulse shaping filter is a root-raised cosine (RRC) with roll-off $\alpha=0.22$ in the frequency domain. The impulse response of the chip impulse filter $RC_0(t)$ is

$$RC_0(t) = \frac{\sin\left(\pi \frac{t}{T_c}(1-\alpha)\right) + 4\alpha \frac{t}{T_c} \cos\left(\pi \frac{t}{T_c}(1+\alpha)\right)}{\pi \frac{t}{T_c} \left(1 - \left(4\alpha \frac{t}{T_c}\right)^2\right)}$$

Where the roll-off factor $\alpha=0.22$ and the chip duration is $T_c = \frac{1}{\text{chiprate}} \approx 0.26042 \mu\text{s}$

6.8.2 ~~Modulation Accuracy~~ Error Vector Magnitude

The Error Vector Magnitude ~~modulation accuracy~~ is a measure of the difference between the measured waveform and the theoretical modulated waveform (the error vector). It is the square root of the ratio of the mean error vector power to the mean reference signal power expressed as a %. The measurement interval is one power control group (timeslot)

6.8.2.1 Minimum requirement

The Error Vector Magnitude ~~modulation accuracy~~ shall not exceed 17.5 % ~~at the maximum output power for the parameters specified in Table xx.~~

Table xx : Parameters for Error Vector Magnitude/Peak Code Domain Error

<u>Parameter</u>	<u>Unit</u>	<u>Level</u>
<u>UE Output Power</u>	dBm	≥ -20
<u>Operating conditions</u>		<u>Normal conditions</u>
<u>Power control step size</u>	<u>dB</u>	<u>1</u>

6.8.3 Peak code domain error

The code domain error is computed by projecting the error vector power onto the code domain at the maximum spreading factor. The error vector for each power code is defined as the ratio to the mean power of the reference waveform expressed in dB. The peak code domain error is defined as the maximum value for the code domain error. The measurement interval is one power control group (timeslot)

The requirement for peak code domain error is only applicable for multi-code transmission.

6.8.3.1 Minimum requirement

The peak code domain error shall not exceed ~~-15~~ -15 dB ~~at spreading factor 4 for the parameters specified in Table xx.~~

The requirements are defined using the UL reference measurement channel specified in Annex A.2.5.

A.2.5 UL reference measurement channel (768 kbps)

The parameters for the UL measurement channel for 768 kbps are specified in Table A.9 and Table A.10.

Table A.9: UL reference measurement channel, physical parameters (768 kbps)

<u>Parameter</u>	<u>Unit</u>	<u>Level</u>
<u>Information bit rate</u>	<u>kbps</u>	<u>2*384</u>
<u>DPDCH₁</u>	<u>kbps</u>	<u>960</u>
<u>DPDCH₂</u>	<u>kbps</u>	<u>960</u>
<u>DPCCH</u>	<u>kbps</u>	<u>15</u>
<u>DPCCH/DPDCH power ratio</u>	<u>dB</u>	<u>-11.48</u>
<u>TFCI</u>	<u>=</u>	<u>On</u>
<u>Puncturing</u>	<u>%</u>	<u>18</u>

Table A.10: UL reference measurement channel, transport channel parameters (768 kbps)

<u>Parameter</u>	<u>DTCH</u>	<u>DCCH</u>
<u>Transport Channel Number</u>	<u>1</u>	<u>2</u>
<u>Transport Block Size</u>	<u>3840</u>	<u>100</u>
<u>Transport Block Set Size</u>	<u>7680</u>	<u>100</u>
<u>Transmission Time Interval</u>	<u>10 ms</u>	<u>40 ms</u>
<u>Type of Error Protection</u>	<u>Turbo Coding</u>	<u>Convolution Coding</u>
<u>Coding Rate</u>	<u>1/3</u>	<u>1/3</u>
<u>Static Rate Matching parameter</u>	<u>1.0</u>	<u>1.0</u>
<u>Size of CRC</u>	<u>16</u>	<u>12</u>

3.3 Abbreviations

For the purposes of the present document, the following abbreviations apply:

ACLR	Adjacent Channel Leakage power Ratio
ACS	Adjacent Channel Selectivity
AICH	Acquisition Indication Channel
BS	Base Station
BER	Bit Error Rate
BLER	Block Error Rate
CW	Continuous Wave (un-modulated signal)
CPICH	Common Pilot Channel
DCH	Dedicated Channel, which is mapped into Dedicated Physical Channel.
DL	Down Link (forward link)
DTX	Discontinuous Transmission
DPCH	Dedicated Physical Channel
$DPCH_E_c$	Average energy per PN chip for DPCH.
$\frac{DPCH_E_c}{I_{or}}$	The ratio of the received energy per PN chip of the DPCH to the total transmit power spectral density at the BS antenna connector.
EIRP	Effective Isotropic Radiated Power
E_b	Average energy per information bit for the PCCPCH, SCCPCH and DPCH, at the UE antenna connector.
$\frac{E_b}{N_t}$	The ratio of combined received energy per information bit to the effective noise power spectral density for the PCCPCH, SCCPCH and DPCH at the UE antenna connector. Following items are calculated as overhead: pilot, TPC, TFCI, CRC, tail, repetition, convolution coding and turbo coding.
E_c	Average energy per PN chip.
$\frac{E_c}{I_{or}}$	The ratio of the average transmit energy per PN chip for different fields or physical channels to the total transmit power spectral density.
FDD	Frequency Division Duplexing
FDR	False transmit format Detection Ratio
FACH	Forward Access Channel
F_{uw}	Frequency of unwanted signal. This is specified in bracket in terms of an absolute frequency(s) or a frequency offset from the assigned channel frequency.
Information Data Rate	Rate of the user information, which must be transmitted over the Air Interface. For example, output rate of the voice codec.
I_o	The total received power spectral density, including signal and interference, as measured at the UE antenna connector.
I_{oc}	The power spectral density of a band limited white noise source (simulating interference from other cells) as measured at the UE antenna connector.
I_{or}	The total transmit power spectral density of the down link at the base station antenna connector.
\hat{I}_{or}	The received power spectral density of the down link as measured at the UE antenna connector.
ISCP	Given only interference is received, the average power of the received signal after de-spreading to the code and combining. Equivalent to the RSCP value but now only interference is received instead of signal.
MER	Message Error Rate
N_t	The effective noise power spectral density at the UE antenna connector.
OCNS	Orthogonal Channel Noise Simulator, a mechanism used to simulate the users or control signals on the other orthogonal channels of a Forward link.
$OCNS_E_c$	Average energy per PN chip for the OCNS.
$\frac{OCNS_E_c}{I_{or}}$	The ratio of the average transmit energy per PN chip for the OCNS to the total transmit power spectral density.
PCCPCH	Primary Common Control Physical Channel
PCH	Paging Channel
$PCCPCH \frac{E_c}{I_o}$	The ratio of the received PCCPCH energy per chip to the total received power spectral density at the UE antenna connector.

$\frac{PCCPCH_E_c}{I_{or}}$	The ratio of the average transmit energy per PN chip for the PCCPCH to the total transmit power spectral density.
PICH	Paging Indicator Channel
PPM	Parts Per Million
RACH	Random Access Channel
RSCP	Given only signal power is received, the average power of the received signal after de-spreading and combining
RSSI	Received Signal Strength Indicator
SCH	Synchronization Channel consisting of Primary and Secondary synchronization channels
SCCPCH	Secondary Common Control Physical Channel.
SCCPCH $_E_c$	Average energy per PN chip for SCCPCH.
SIR	Signal to Interference ratio
SSDT	Site Selection Diversity Transmission
TDD	Time Division Duplexing
TFCI	Transport Format Combination Indicator
TPC	Transmit Power Control
UE	User Equipment
UL	Up Link (reverse link)
UTRA	UMTS Terrestrial Radio Access

8 Performance requirement

8.x Blind transport format detection

Performance of Blind transport format detection is determined by the Block Error Ratio (BLER) values and by the measured average transmitted DPCH E_c/I_{or} value.

8.x.1 Minimum requirement

For the parameters specified in Table xx1 the BLER and FDR shall not exceed the piece-wise linear BLER curve specified by the points in table xx2

Table xx1: Test parameters for Blind transport format detection

Parameter	Unit	Test 1	Test 2	Test 3	Test 4	Test 5	Test 6
\hat{I}_{or}/I_{oc}	dB	-1			-3		
I_{oc}	dBm/3.84 MHz	-60					
Information Data Rate	kbps	12.2 (rate 1)	7.95 (rate 2)	1.95 (rate 3)	12.2 (rate 1)	7.95 (rate 2)	1.95 (rate 3)
propagation condition	:	static			multi-path fading case 3		
TFCI	:	off					

Table xx2: The Requirements for DCH reception in Blind transport format detection

Test Number	$\frac{DPCH_E_c}{I_{or}}$	BLER	FDR
1	[-17.7dB]	10^{-2}	10^{-4}
2	[-17.8dB]	10^{-2}	10^{-4}
3	[-18.4dB]	10^{-2}	10^{-4}
4	[-13dB]	10^{-2}	10^{-4}
5	[-13.2dB]	10^{-2}	10^{-4}
6	[-13.8dB]	10^{-2}	10^{-4}

* The value of DPCH E_c/I_{or} , I_{oc} , and I_{or}/I_{oc} are defined in case of DPCH is transmitted

Note

- In the test, 9 deferent Transport Format Combinations(table.xx3) are informed during the call set up procedure, so that UE have to detect correct transport format in this 9 candidates.

Table.xx3 Transport format combinations informed during the call set up procedure in the test

	1	2	3	4	5	6	7	8	9
DTCH	12.2k	10.2k	7.95k	7.4k	6.7k	5.9k	5.15k	4.75k	1.95k
DCCH					2.4k				

Annex A (normative): Measurement channels

A.3 DL reference measurement channel for BTFD performance requirements

The parameters for DL reference measurement channel for BTFD are specified in Table A.17 and Table A.18. The channel coding for information is shown in figure A.9, A.10, and A.11.

Table A.17: DL reference measurement channel physical parameters for Blind transport format detection

Parameter	Unit	Rate 1	Rate 2	Rate 3
Information bit rate	kbps	12.2	7.95	1.95
DPCH	ksp/s		30	
TFCI	=		Off	
Repetition	%		5	

Table A.18: DL reference measurement channel, transport channel parameters for Blind transport format detection

Parameter	DTCH			DCCH
	Rate 1	Rate 2	Rate 3	
Transport Channel Number	1			2
Transport Block Size	244	159	39	96
Transport Block Set Size	244	159	39	96
Transmission Time Interval	20 ms			40 ms
Type of Error Protection	Convolution Coding			Convolution Coding
Coding Rate	1/3			1/3
Static Rate Matching parameter	1.0			1.0
Size of CRC	12			16
Position of TrCH in radio frame	fixed			fixed

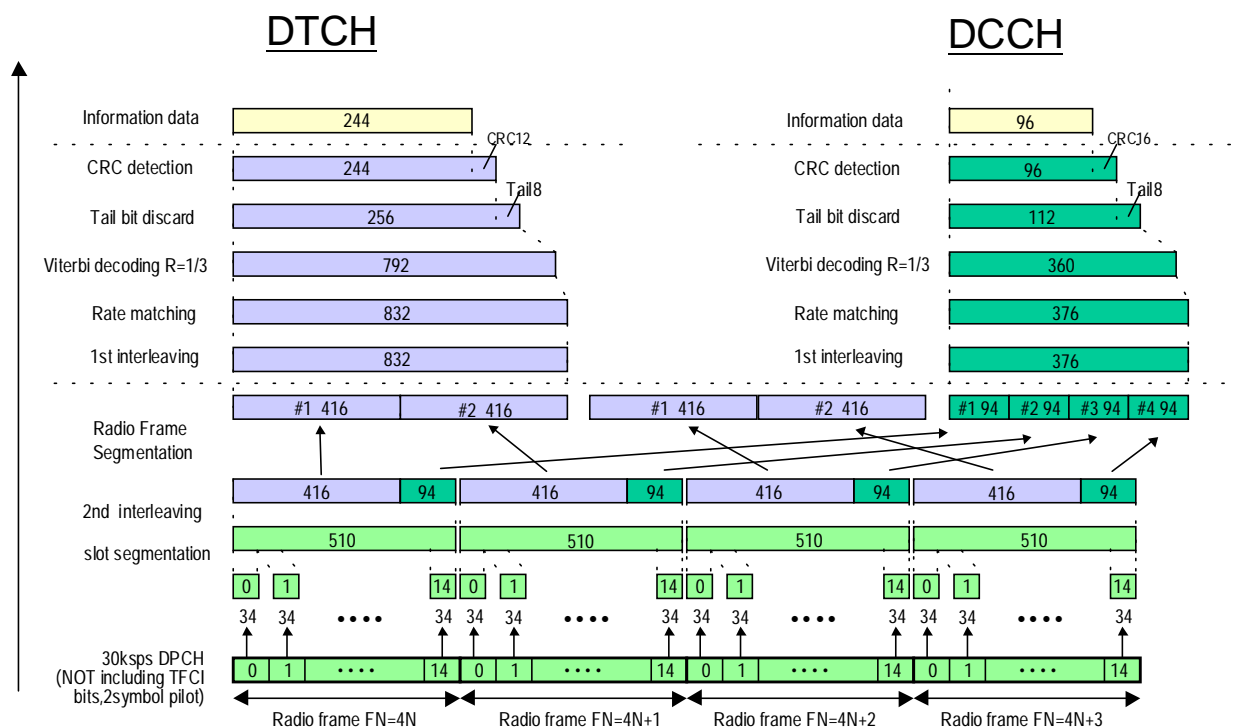

Figure A.9(Informative): Channel coding of DL reference measurement channel for BTFD (Rate 1)

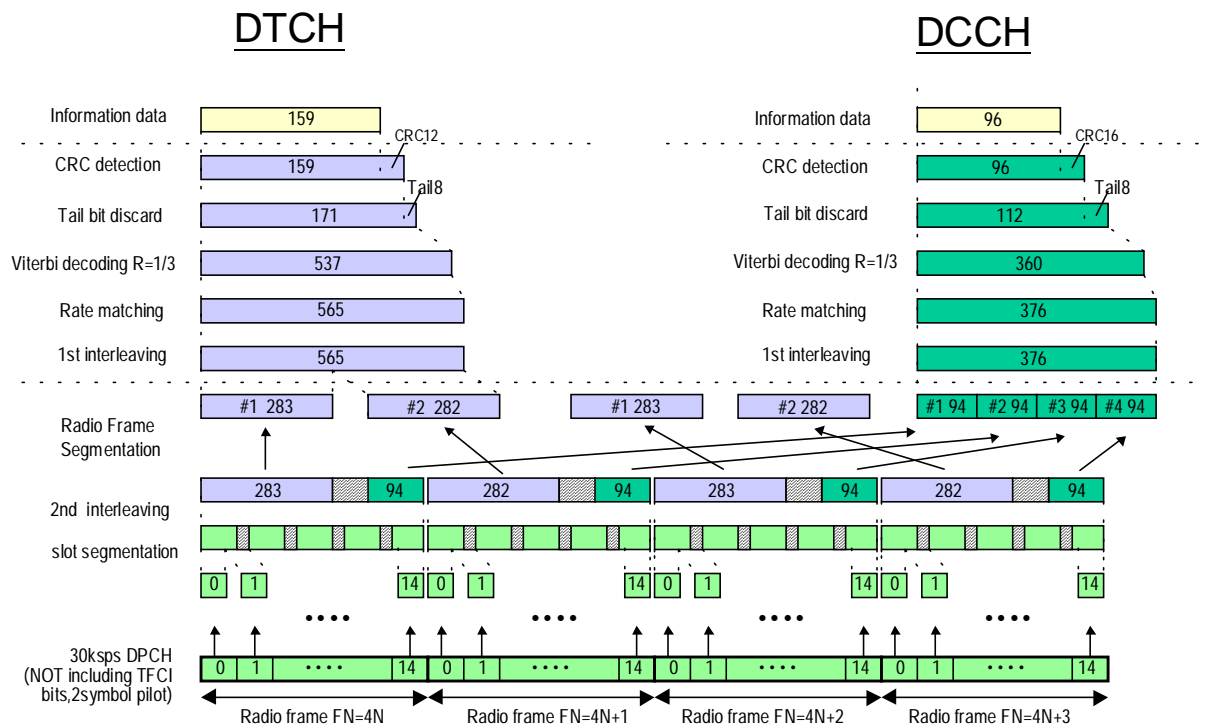

Figure A.10(Informative): Channel coding of DL reference measurement channel for BTFD (Rate 2)

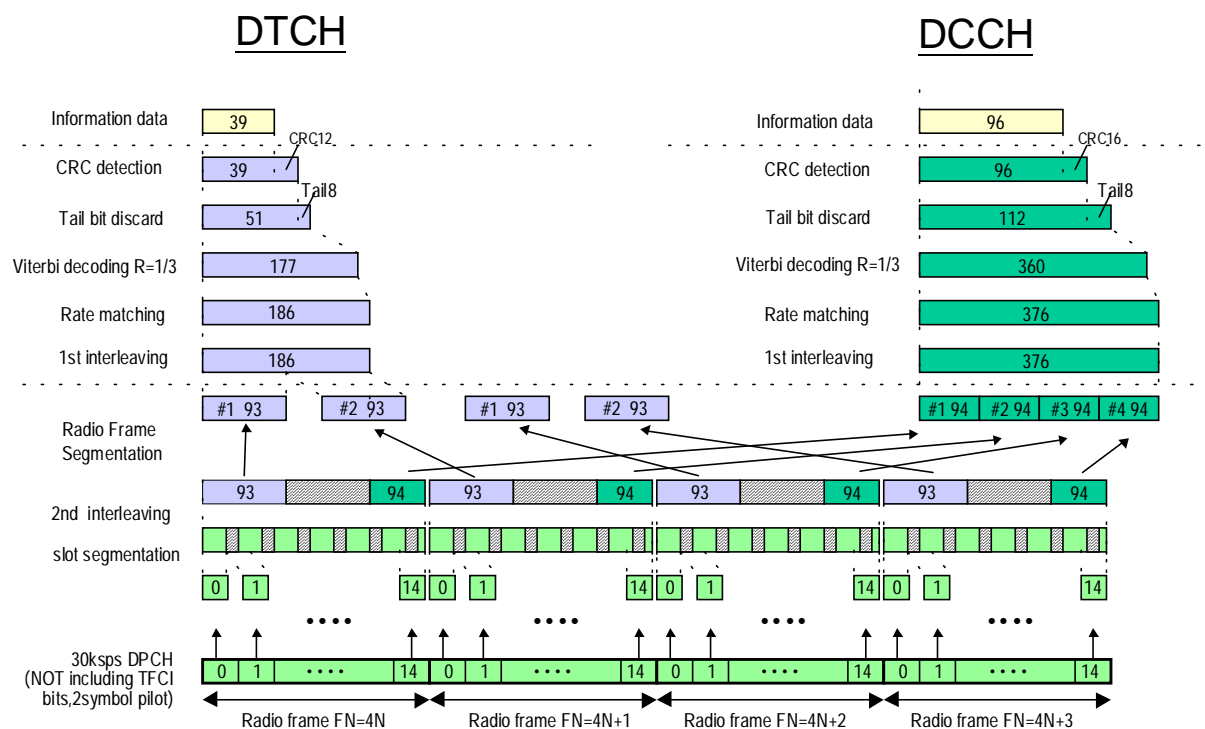

Figure A.11(Informative): Channel coding of DL reference measurement channel for BTFD (Rate 3)

A.34 DL reference compressed mode parameters

The following parameters characterise the transmission gap :

TGL : 7

SFN : FFS

SN : FFS

The following parameters characterise the compressed mode pattern :

TGP : FFS

TGL : 7

TGD : FFS

PD: FFS

SFN : FFS

PCM: FFS

Transmission time reduction method FFS

CHANGE REQUEST

Please see embedded help file at the bottom of this page for instructions on how to fill in this form correctly.

25.101 CR **029**

Current Version: **3.1.0**

GSM (AA.BB) or 3G (AA.BBB) specification number ↑

↑ CR number as allocated by MCC support team

For submission to: **RAN #7**
list expected approval meeting # here ↑

for approval
for information

strategic
non-strategic (for SMG use only)

Form: CR cover sheet, version 2 for 3GPP and SMG The latest version of this form is available from: ftp://ftp.3gpp.org/Information/CR-Form-v2.doc

Proposed change affects:

(at least one should be marked with an X)

(U)SIM ME UTRAN / Radio Core Network

Source:

RAN WG4

Date: 29-02-00

Subject:

CR to 6.5.2 in TS 25.101 - CPCH

Work item:

Category:

(only one category shall be marked with an X)

- F Correction
A Corresponds to a correction in an earlier release
B Addition of feature
C Functional modification of feature
D Editorial modification

Release:

- Phase 2
Release 96
Release 97
Release 98
Release 99
Release 00

Reason for change:

In TS 25.101, there are possible UE transmit ON/OFF scenarios such as RACH or UL slotted mode. The CPCH is similar feature to RACH. Therefore, this contribution adds CPCH as one of the possible UE transmit ON/OFF scenarios.

Clauses affected:

6.5.2

Other specs affected:

Other 3G core specifications → List of CRs:
Other GSM core specifications → List of CRs:
MS test specifications → List of CRs:
BSS test specifications → List of CRs:
O&M specifications → List of CRs:

Other comments:

6.5 Transmit ON/OFF power

6.5.1 Transmit OFF power

The transmit OFF power state is when the UE does not transmit except during UL DTX mode. This parameter is defined as the maximum output transmit power within the channel bandwidth when the transmitter is OFF.

6.5.1.1 Minimum requirement

The requirement for the transmit OFF power shall be better than -50 dBm measured with a filter that has a Root-Raised Cosine (RRC) filter response with a roll off $\alpha = 0.22$ and a bandwidth equal to the chip rate

6.5.2 Transmit ON/OFF Time mask

The time mask for transmit ON/OFF defines the ramping time allowed for the UE between transmit OFF power and transmit ON power. Possible ON/OFF scenarios are RACH, CPCH or UL slotted mode

6.5.2.1 Minimum requirement

The transmit power levels versus time should meet the mask specified in figure 1a

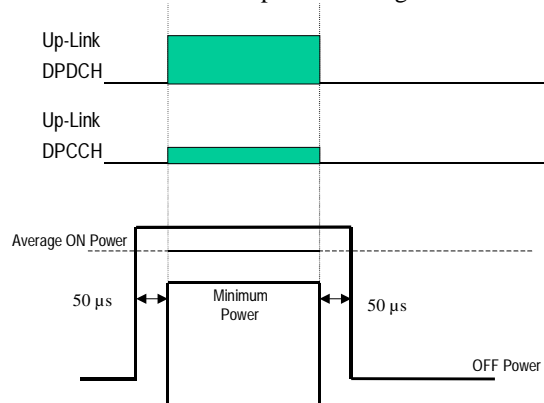

Figure 1a: Transmit ON/OFF template

6.5.3 Change of TFC

A change of TFC (Transport Format Combination) in uplink means that the power in the uplink varies according to the change in data rate. DTX, where the DPCH is turned off, is a special case of variable data, which is used to minimise the interference between UE(s) by reducing the UE transmit power when voice, user or control information is not present.

6.5.3.1 Minimum requirement

A change of output power is required when the TFC, and thereby the data rate, is changed. The ratio of the amplitude between the DPDCH codes and the DPCCH code will vary. The power step due to a change in TFC shall be calculated in the UE so that the power transmitted on the DPCCH shall follow the inner loop power control. The power step shall then be rounded to the closest integer dB value. The accuracy of the power step, given the step size is specified in Table 6b.

CHANGE REQUEST

Please see embedded help file at the bottom of this page for instructions on how to fill in this form correctly.

25.101 CR 030

Current Version: **3.1.0**

GSM (AA.BB) or 3G (AA.BBB) specification number ↑

↑ CR number as allocated by MCC support team

For submission to: **RAN #7**
list expected approval meeting # here ↑

for approval
for information

strategic
non-strategic (for SMG use only)

Form: CR cover sheet, version 2 for 3GPP and SMG The latest version of this form is available from: <ftp://ftp.3gpp.org/Information/CR-Form-v2.doc>

Proposed change affects: (U)SIM ME UTRAN / Radio Core Network
(at least one should be marked with an X)

Source: Vodafone Airtouch **Date:** 00-02-27

Subject: Clarification of ACLR

Work item:

Category: F Correction
A Corresponds to a correction in an earlier release
B Addition of feature
C Functional modification of feature
D Editorial modification
(only one category shall be marked with an X)

Release: Phase 2
Release 96
Release 97
Release 98
Release 99
Release 00

Reason for change: This CR clarifies the definition of ACLR.

Clauses affected: 6.6.2.2, 6.6.2.2.1

Other specs affected: Other 3G core specifications → List of CRs:
Other GSM core specifications → List of CRs:
MS test specifications → List of CRs:
BSS test specifications → List of CRs:
O&M specifications → List of CRs:

Other comments:

6.6.2.2 Adjacent Channel Leakage power Ratio (ACLR)

Adjacent Channel Leakage power Ratio (ACLR) is the ratio of the transmitted power to the power measured ~~after a receiver filter~~ in ~~an~~ the adjacent channel(s). Both the transmitted power and the ~~received adjacent channel~~ power are measured with a filter that has a Root-Raised Cosine (RRC) filter response with roll-off $\alpha = 0.22$ and a bandwidth equal to the chip rate.

6.6.2.2.1 Minimum requirement

If the adjacent channel power is greater than -50dBm then T the ACLR shall be ~~better~~ higher than the value specified in Table 8.

Table 8:UE ACLR

Power Class	Adjacent channel relative to UE channel	ACLR limit
3	+ 5 MHz or – 5 MHz	33 dB or -50dBm which ever is higher
3	+ 10 MHz or – 10 MHz	43 dB or -50dBm which ever is higher
4	+ 5 MHz or – 5 MHz	33 dB or -50dBm which ever is higher
4	+ 10 MHz or –10 MHz	43 dB or -50dBm which ever is higher

Note

1. The requirement shall still be met in the presence of ACLR due to switching transients ~~shall not exceed the limits in Table 8.~~
2. The ACLR requirements reflect what can be achieved with present state of the art technology.
3. Requirement on the UE shall be reconsidered when the state of the art technology progresses.

CHANGE REQUEST

Please see embedded help file at the bottom of this page for instructions on how to fill in this form correctly.

25.101 CR 031

Current Version: **3.1.0**

GSM (AA.BB) or 3G (AA.BBB) specification number ↑

↑ CR number as allocated by MCC support team

For submission to:
list expected approval meeting # here ↑

for approval
for information

strategic
non-strategic (for SMG use only)

Form: CR cover sheet, version 2 for 3GPP and SMG The latest version of this form is available from: ftp://ftp.3gpp.org/Information/CR-Form-v2.doc

Proposed change affects:

(at least one should be marked with an X)

(U)SIM ME UTRAN / Radio Core Network

Source:

RAN WG4

Date:

2000-02-29

Subject:

Correction for reference measurement channel in TS 25.101

Work item:

Category:

(only one category shall be marked with an X)

F Correction
A Corresponds to a correction in an earlier release
B Addition of feature
C Functional modification of feature
D Editorial modification

Release:

Phase 2
Release 96
Release 97
Release 98
Release 99
Release 00

Reason for change:

It is found that there are some wrong points in the current reference measurement channel in Annex A of TS25.101v3.1.0. Therefore it is proposed to correct some wrong points in the current reference measurement channels. Revised points are as follows,

1. Revise the parameter of "DPCCH/DPDCH" in the tables of UL measurement channels in order to align with table.1:The quantization of gain parameters of TS25.213
2. Remove the parameter of "Position of TrCH in radio frame" from the tables of UL reference measurement channel, transport channel parameters
3. Change the parameter of "Transport channel number" between DCCH and DTCH in the table of UL/DL reference measurement channel, transport channel parameters, in order to align with the figure of channel coding
4. Change the number of bits of DCCH from 96 bits to 100 bits, and change the number of CRC bits attached to DCCH from 16bits to 12bits based on LS from TSG-T WG1 RF-SWG (Tdoc R4-000172)

Clauses affected:

Annex A

Other specs affected:

Other 3G core specifications → List of CRs:
Other GSM core specifications → List of CRs:
MS test specifications → List of CRs:
BSS test specifications → List of CRs:
O&M specifications → List of CRs:

Other comments:

Annex A (normative): Measurement channels

A.1 General

The measurement channels in this annex are defined to derive the requirements in section 6, 7 and 8. The measurement channels represent example configuration of radio access bearers for different data rates.

The measurement channel for 12.2 kbps shall be supported by any UE both in up- and downlink. Support for other measurement channels is depending on the UE Radio Access capabilities.

A.2 UL reference measurement channel

A.2.1 UL reference measurement channel (12.2 kbps)

The parameters for the 12.2 kbps UL reference measurement channel are specified in Table A.1 and Table A.2. The channel coding for information is shown in figure A.1

Table A.1: UL reference measurement channel physical parameters (12.2 kbps)

Parameter	Unit	Level
Information bit rate	kbps	12.2
DPDCH	kbps	60
DPCCH	kbps	15
DPCCH/DPDCH power ratio	dB	--5.46 6
TFCI	-	On
Repetition	%	23

Table A.2: UL reference measurement channel, transport channel parameters (12.2 kbps)

Parameters	DTCH DCCH	DCCH DTCH
Transport Channel Number	1 (TBD by WG2)	2 (TBD by WG2)
Transport Block Size	224 96	100 244
Transport Block Set Size	224 96	100 244
Transmission Time Interval	20 40 ms	40 20 ms
Type of Error Protection	Convolution Coding	Convolution Coding
Coding Rate	1/3	1/3
Static Rate Matching parameter	1.0	1.0
Size of CRC	16	12 16
Position of TrCH in radio frame	Fixed	fixed

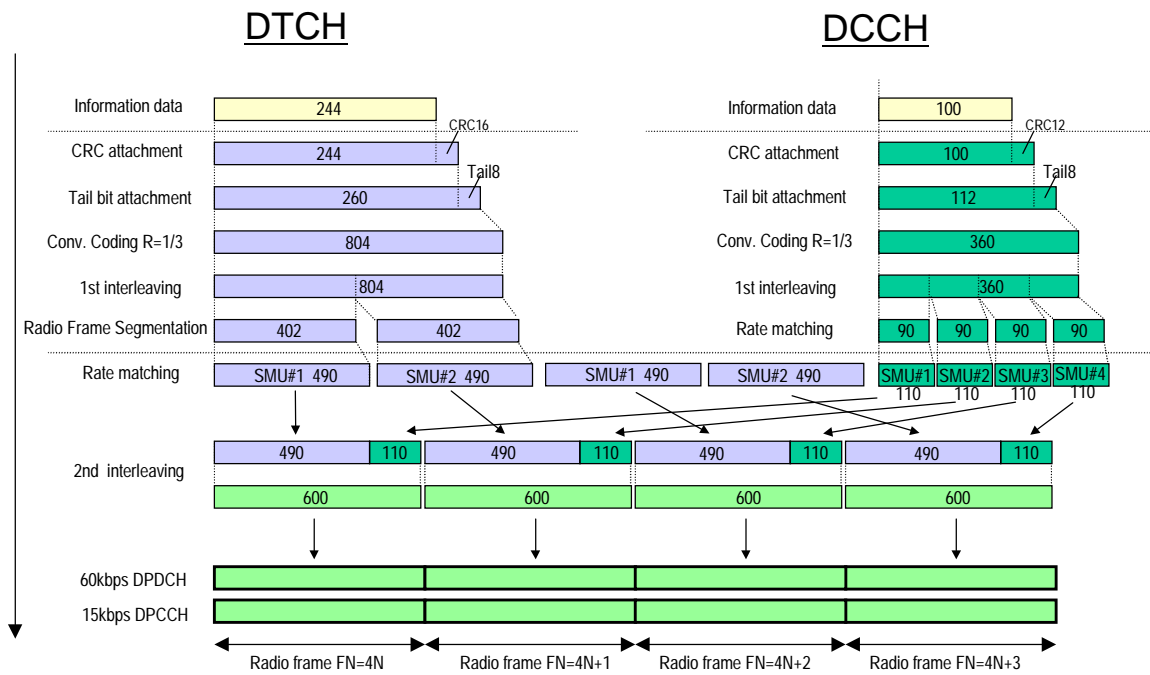

Figure A.1(Informative): Channel coding of UL reference measurement channel (12.2 kbps)

A.2.2 UL reference measurement channel (64 kbps)

The parameters for the 64 kbps UL reference measurement channel are specified in Table A.3 and Table A.4. The channel coding for information is shown in figure A.2. This measurement channel is not currently used in TS25.101 but can be used for future requirements.

Table A.3: UL reference measurement channel (64 kbps)

Parameter	Unit	Level
Information bit rate	kbps	64
DPDCH	kbps	240
DPCCH	kbps	15
DPCCH/DPDCH power ratio	dB	-9.54 9
TFCI	-	On
Repetition	%	18

Table A.4: UL reference measurement channel, transport channel parameters (64kbps)

Parameter	DTCH DCCH	DCCH DTCH
Transport Channel Number	1 (TBD by WG2)	2 (TBD by WG2)
Transport Block Size	1280 96	100+280
Transport Block Set Size	1280 96	100+280
Transmission Time Interval	20 40 ms	40 20 ms
Type of Error Protection	Turbo Convolution Coding	Convolution Turbo Coding
Coding Rate	1/3	1/3
Static Rate Matching parameter	1.0	1.0

Size of CRC	16	<u>12</u> <u>46</u>
Position of TrCH in radio frame	Fixed	Fixed

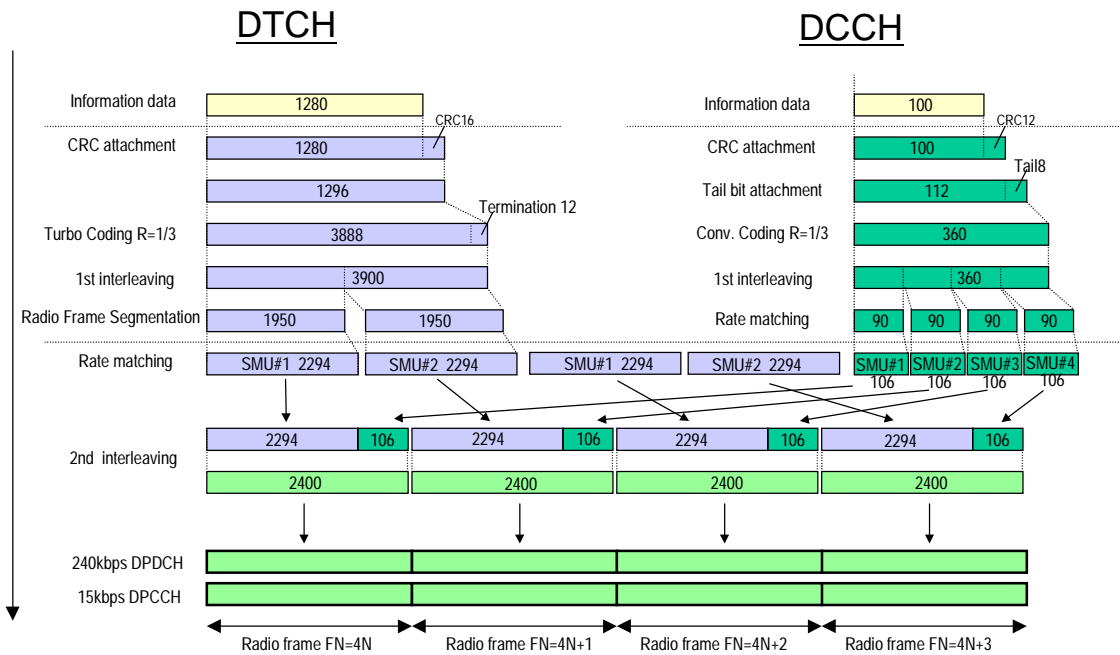

Figure A.2 (Informative): Channel coding of UL reference measurement channel (64 kbps)

A.2.3 UL reference measurement channel (144 kbps)

The parameters for the 144 kbps UL reference measurement channel are specified in Table A.5 and Table A.6. The channel coding for information is shown in Figure A.3. This measurement channel is not currently used in TS25.101 but can be used for future requirements.

Table A.5: UL reference measurement channel (144 kbps)

Parameter	Unit	Level
Information bit rate	kbps	144
DPDCH	kbps	480
DPCCH	kbps	15
DPCCH/DPDCH <u>power ratio</u>	dB	<u>-11.48</u> <u>12</u>
TFCI	-	On
Repetition	%	8

Table A.6: UL reference measurement channel, transport channel parameters (144kbps)

Parameters	<u>DTCH</u> <u>DCCH</u>	<u>DCCH</u> <u>DTCH</u>
Transport Channel Number	1 (<u>TBD by WG2</u>)	2 (<u>TBD by WG2</u>)
Transport Block Size	<u>2880</u> <u>96</u>	<u>100</u> <u>2880</u>
Transport Block Set Size	<u>2880</u> <u>96</u>	<u>100</u> <u>2880</u>
Transmission Time Interval	<u>20</u> <u>40</u> ms	<u>40</u> <u>20</u> ms
Type of Error Protection	<u>Turbo</u> <u>Convolution</u>	<u>Convolution</u> <u>Turbo</u>

	Coding	Coding
Coding Rate	1/3	1/3
Static Rate Matching parameter	1.0	1.0
Size of CRC	16	12+6
Position of TrCH in radio frame	Fixed	Fixed

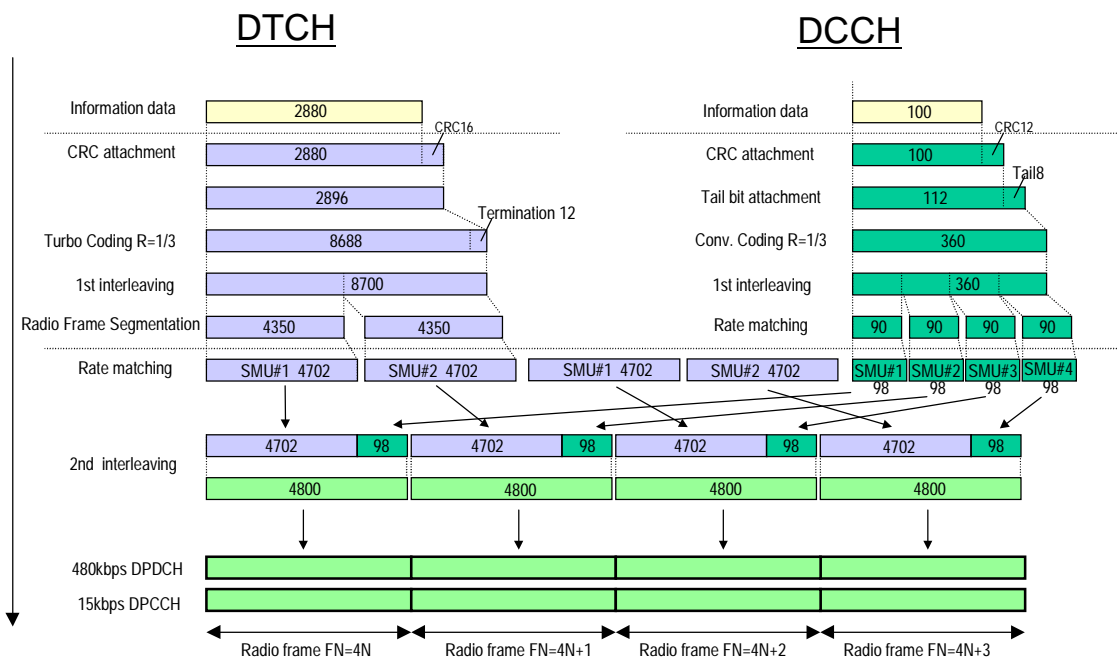

Figure A.3 (Informative): Channel coding of UL reference measurement channel (144 kbps)

A.2.4 UL reference measurement channel (384 kbps)

The parameters for the 384 kbps UL reference measurement channel are specified in Table A.7 and Table A.8. The channel coding for information is shown in Figure A.4. This measurement channel is not currently used in TS25.101 but can be used for future requirements.

Table A.7: UL reference measurement channel (384 kbps)

Parameter	Unit	Level
Information bit rate	kbps	384
DPDCH	kbps	960
DPCCH	kbps	15
DPCCH/DPDCH power ratio	dB	-11.48+2
TFCI	-	On
Puncturing	%	18

Table A.8: UL reference measurement channel, transport channel parameters (384 kbps)

Parameter	DTCH DCCH	DCCH DTCH
-----------	-----------	-----------

Transport Channel Number	1 (TBD by WG2)	2 (TBD by WG2)
Transport Block Size	3840 96	100 3840
Transport Block Set Size	7680 96	100 7680
Transmission Time Interval	20 40 ms	40 20 ms
Type of Error Protection	Turbo Convolution Coding	Convolution Turbo Coding
Coding Rate	1/3	1/3
Static Rate Matching parameter	1.0	1.0
Size of CRC	16	12 16
Position of TrCH in radio frame	Fixed	Fixed

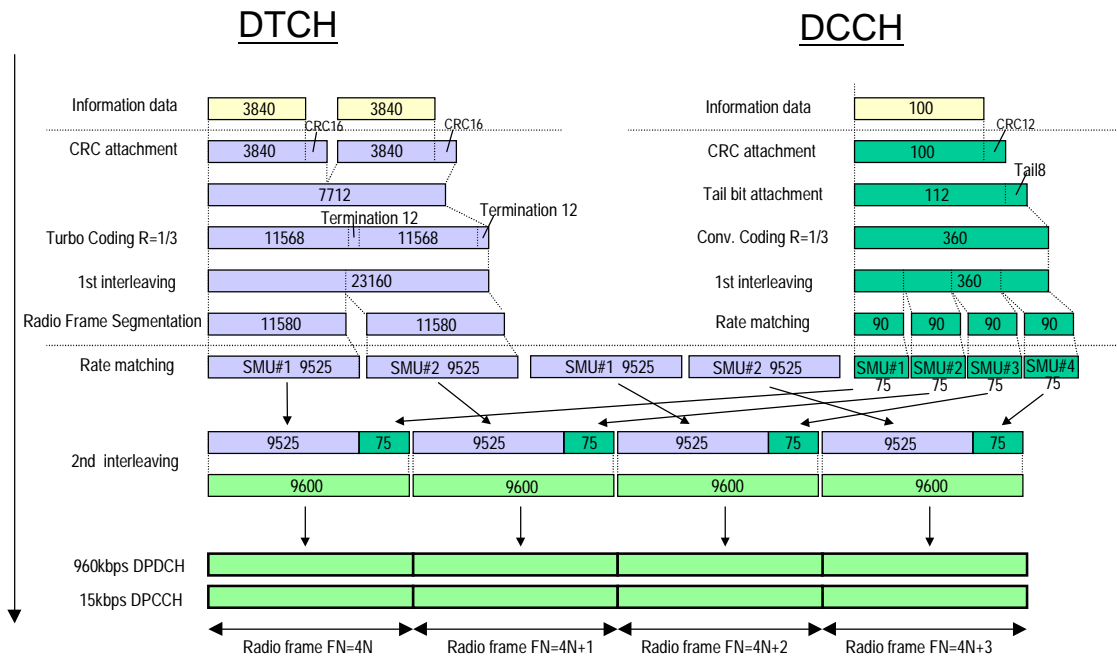

Figure A.4 (Informative): Channel coding of UL reference measurement channel (384 kbps)

A.3 DL reference measurement channel

A.3.1 DL reference measurement channel (12.2 kbps)

The parameters for the 12.2 Kbps DL reference measurement channel are specified in Table A. 9 and Table A.10. The channel coding is shown for information in figure A.5

Table A.9: DL reference measurement channel physical parameters (12.2 kbps)

Parameter	Unit	Level
Information bit rate	kbps	12.2
DPCH	ksps	30
TFCI	-	On
Puncturing	%	14.5

Table A.10: DL reference measurement channel, transport channel parameters (12.2 kbps)

Parameter	DTCH DCCH	DCCH DTCH
Transport Channel Number	1 (TBD by WG2)	2 (TBD by WG2)
Transport Block Size	244 96	100 244
Transport Block Set Size	244 96	100 244
Transmission Time Interval	20 40 ms	40 20 ms
Type of Error Protection	Convolution Coding	Convolution Coding
Coding Rate	1/3	1/3
Static Rate Matching parameter	1.0	1.0
Size of CRC	16	12 16
Position of TrCH in radio frame	fixed	fixed

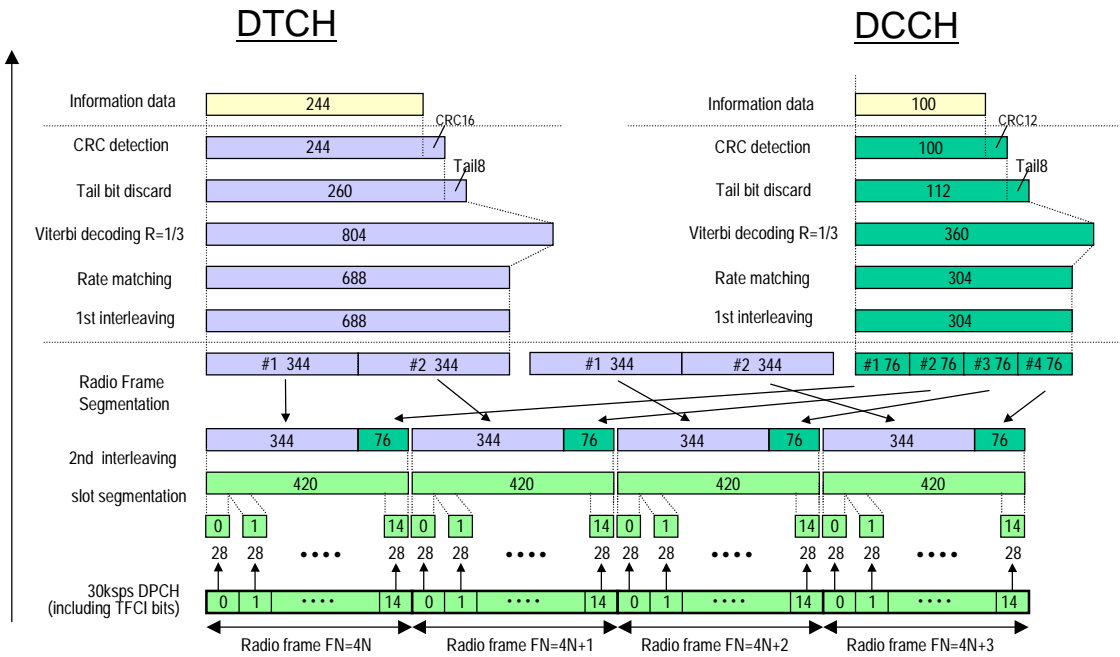

Figure A.5 (Informative): Channel coding of DL reference measurement channel (12.2 kbps)

A.3.2 DL reference measurement channel (64 kbps)

The parameters for the DL reference measurement channel for 64 kbps are specified in Table A.11 and Table A.12. The channel coding is shown for information in Figure A.6

Table A.11: DL reference measurement channel physical parameters (64 kbps)

Parameter	Unit	Level
Information bit rate	kbps	64
DPCH	ksps	120
TFCI	-	On
Repetition	%	2.9

Table A.12: DL reference measurement channel, transport channel parameters (64 kbps)

Parameter	<u>DTCH</u> <u>DCCH</u>	<u>DCCH</u> <u>DTCH</u>
Transport Channel Number	1 (TBD by WG2)	2 (TBD by WG2)
Transport Block Size	1280 96	100 1280
Transport Block Set Size	1280 96	100 1280
Transmission Time Interval	20 40 ms	40 20 ms
Type of Error Protection	Turbo Convolution Coding	Convolution Turbo Coding
Coding Rate	1/3	1/3
Static Rate Matching parameter	1.0	1.0
Size of CRC	16	12 16
Position of TrCH in radio frame	fixed	fixed

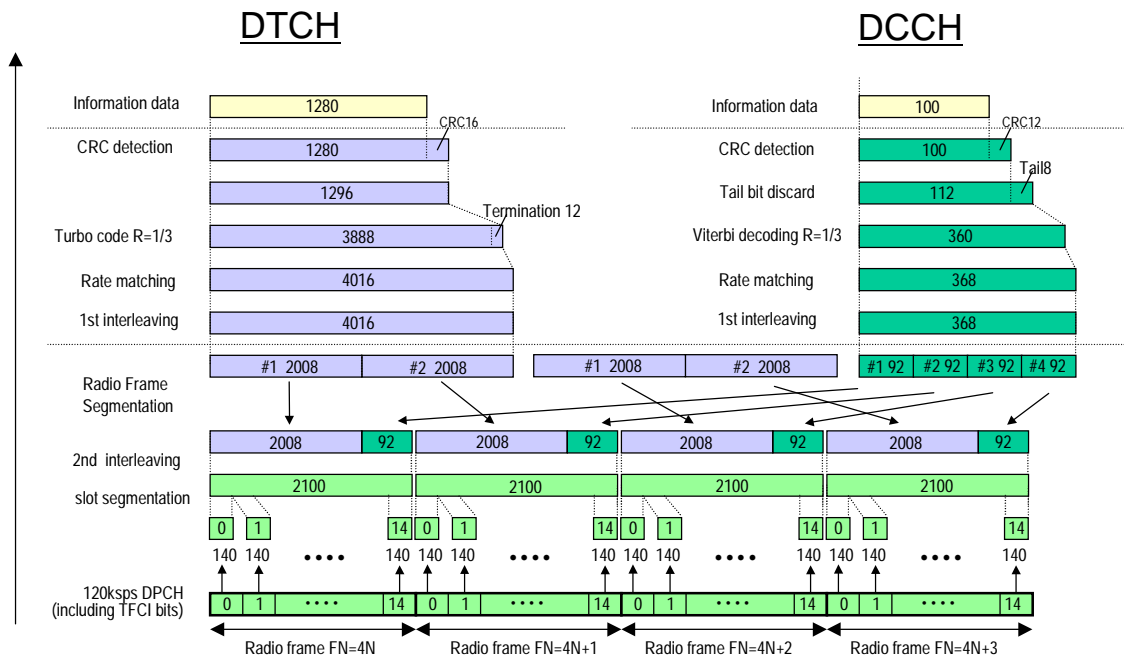

Figure A.6 (Informative): Channel coding of DL reference measurement channel (64 kbps)

A.3.3 DL reference measurement channel (144 kbps)

The parameters for the DL measurement channel for 144 kbps are specified in Table A.13 and Table A.14. The channel coding is shown for information in Figure A.7

Table A.13: DL reference measurement channel physical parameters (144 kbps)

Parameter	Unit	Level
Information bit rate	kbps	144
DPCH	ksps	240
TFCI	-	On
Puncturing	%	2.7

Table A.14: DL reference measurement channel, transport channel parameters (144 kbps)

Parameter	<u>DTCH</u> <u>DCCH</u>	<u>DCCH</u> <u>DTCH</u>
Transport Channel Number	1 (TBD by WG2)	2 (TBD by WG2)
Transport Block Size	<u>2880</u> <u>96</u>	<u>100</u> <u>2880</u>
Transport Block Set Size	<u>2880</u> <u>96</u>	<u>100</u> <u>2880</u>
Transmission Time Interval	<u>20</u> <u>40</u> ms	<u>40</u> <u>20</u> ms
Type of Error Protection	<u>Turbo</u> <u>Convolution</u> Coding	<u>Convolution</u> <u>Turbo</u> Coding
Coding Rate	1/3	1/3

Static Rate Matching parameter	1.0	1.0
Size of CRC	16	12 16
Position of TrCH in radio frame	fixed	fixed

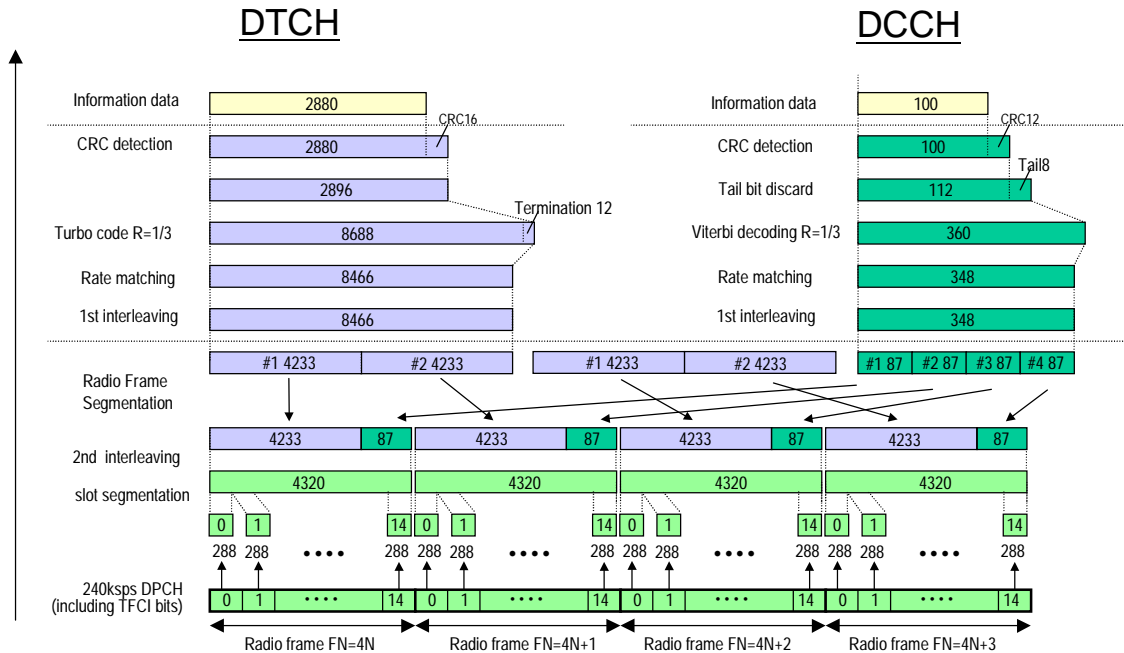

Figure A.7 (Informative): Channel coding of DL reference measurement channel (144 kbps)

A.3.4 DL reference measurement channel (384 kbps)

The parameters for the DL measurement channel for 384 kbps are specified in Table A.15 and Table A.16. The channel coding is shown for information in Figure A.8

Table A.15: DL reference measurement channel, physical parameters (384 kbps)

Parameter	Unit	Level
Information bit rate	kbps	384
DPCH	ksps	480
TFCI		On
Puncturing	%	22

Table A.16: DL reference measurement channel, transport channel parameters (384 kbps)

Parameter	DTCH DCCH	DCCH DTCH
Transport Channel Number	1 (TBD by WG2)	2 (TBD by WG2)
Transport Block Size	3840 96	100 3840
Transport Block Set Size	7680 96	100 7680
Transmission Time Interval	20 40 ms	40 20 ms
Type of Error Protection	Turbo Convolution Coding	Convolution Turbo Coding

Coding Rate	1/3	1/3
Static Rate Matching parameter	1.0	1.0
Size of CRC	16	16 12
Position of TrCH in radio frame	fixed	fixed

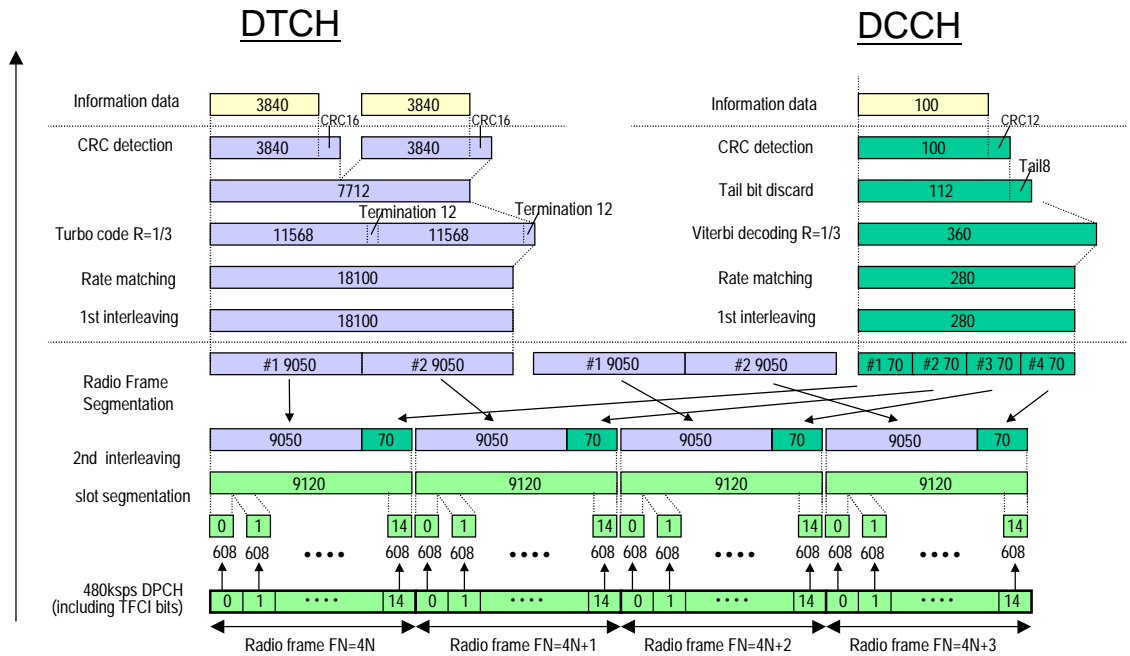

Figure A.8 (Informative): Channel coding of DL reference measurement channel (384 kbps)

A.4 DL reference compressed mode parameters

The following parameters characterise the transmission gap :

TGL : 7

SFN : FFS

SN : FFS

The following parameters characterise the compressed mode pattern :

TGP : FFS

TGL : 7

TGD : FFS

PD: FFS

SFN : FFS

PCM: FFS

Transmission time reduction method FFS

CHANGE REQUEST

Please see embedded help file at the bottom of this page for instructions on how to fill in this form correctly.

25.101 CR 032

Current Version: **3.1.0**

GSM (AA.BB) or 3G (AA.BBB) specification number ↑

↑ CR number as allocated by MCC support team

For submission to: **TSG-RAN #7**

list expected approval meeting # here



for approval

for information

strategic

Non-strategic

(for SMG use only)

Form: CR cover sheet, version 2 for 3GPP and SMG

The latest version of this form is available from: <http://ftp.3gpp.org/Information/CR-Form-v2.doc>

Proposed change affects:

(at least one should be marked with an X)

(U)SIM

ME

UTRAN / Radio

Core Network

Source:

RAN WG4

Date:

2000-03-02

Subject:

Modifications to requirements for power control steps in uplink

Work item:

Category:

(only one category shall be marked with an X)

F Correction

A Corresponds to a correction in an earlier release

B Addition of feature

C Functional modification of feature

D Editorial modification

<input checked="" type="checkbox"/>
<input type="checkbox"/>
<input type="checkbox"/>
<input type="checkbox"/>
<input type="checkbox"/>

Release:

Phase 2

Release 96

Release 97

Release 98

Release 99

Release 00

<input type="checkbox"/>
<input type="checkbox"/>
<input type="checkbox"/>
<input type="checkbox"/>
<input checked="" type="checkbox"/>
<input type="checkbox"/>

Reason for change:

Tightening of requirement on 0dB steps, reintroduction of requirements on power control steps under power control algorithm 2, and changing requirement on 3dB steps to be consistent with 25.214.

Clauses affected:

6.4.2.1.1

Other specs affected:

Other 3G core specifications

Other GSM core specifications

MS test specifications

BSS test specifications

O&M specifications

<input type="checkbox"/>
<input type="checkbox"/>
<input type="checkbox"/>
<input type="checkbox"/>
<input type="checkbox"/>

→ List of CRs:

→ List of CRs:

→ List of CRs:

→ List of CRs:

→ List of CRs:

Other comments:



help.doc

<----- double-click here for help and instructions on how to create a CR.

6.4.2 Inner loop power control in the uplink

Inner loop power control in the Uplink is the ability of the UE transmitter to adjust its output power in accordance with one or more TPC commands received in the downlink.

6.4.2.1 Power control steps

The power control step is the change in the UE transmitter output power in response to a single TPC command, TPC_cmd, derived at the UE.

6.4.2.1.1 Minimum requirement

The UE transmitter shall have the capability of changing the output power with a step size of 1, 2 and 3 dB according to the value of Δ_{TPC} or $\Delta_{\text{RP-TPC}}$, in the slot immediately after the TPC_cmd can be derived

- (a) The transmitter output power step due to inner loop power control shall be within the range shown in Table 5.
 (b) The transmitter average output power step due to inner loop power control shall be within the range shown in Table 6. [Here a TPC_cmd group is a set of TPC_cmd values derived from a corresponding sequence of TCP commands of the same duration.](#)

Table 5: Transmitter power control range

TPC_cmd	Transmitter power control range					
	1 dB step size		2 dB step size		3 dB step size	
	Lower	Upper	Lower	Upper	Lower	Upper
+1	+0.5 dB	+1.5 dB	+1 dB	+3 dB	+1.5 dB	+4.5 dB
0	-0.5 dB	+0.5 dB	-0.5 dB	+0.5 dB	-0.5 dB	+0.5 dB
-1	-0.5 dB	-1.5 dB	-1 dB	-3 dB	-1.5 dB	-4.5 dB

Table 6: Transmitter average power control range

TPC_cmd_group	Transmitter power control range after 10 equal TPC_cmd groups				Transmitter power control range after 7 equal TPC_cmd groups	
	1 dB step size		2 dB step size		3 dB step size	
	Lower	Upper	Lower	Upper	Lower	Upper
+1	+8 dB	+12 dB	+16 dB	+24 dB	+24-16 dB	+36-26 dB
0	-2-1 dB	+2-1 dB	-2-1 dB	+2-1 dB	-2-1 dB	+2-1 dB
-1	-8 dB	-12 dB	-16 dB	-24 dB	-24-16 dB	-36-26 dB
0.0.0.0,+1	+6 dB	+14 dB	N/A	N/A	N/A	N/A
0.0.0.0,-1	-6 dB	-14 dB	N/A	N/A	N/A	N/A

6.4.3 Minimum transmit output power

The minimum controlled output power of the UE is when the power control setting is set to a minimum value. This is when both the inner loop and open loop power control indicate a minimum transmit output power is required.

6.4.3.1 Minimum requirement

The minimum transmit power shall be better than -44 dBm measured with a filter that has a Root-Raised Cosine (RRC) filter response with a roll off $\alpha = 0.22$ and a bandwidth equal to the chip rate.

CHANGE REQUEST

Please see embedded help file at the bottom of this page for instructions on how to fill in this form correctly.

25.101

CR 033

Current Version: 3.1.0

GSM (AA.BB) or 3G (AA.BBB) specification number ↑

↑ CR number as allocated by MCC support team

For submission to:
list expected approval meeting # here ↑

for approval
for information

strategic
non-strategic (for SMG use only)

Form: CR cover sheet, version 2 for 3GPP and SMG The latest version of this form is available from: ftp://ftp.3gpp.org/Information/CR-Form-v2.doc

Proposed change affects:
(at least one should be marked with an X)

(U)SIM ME UTRAN / Radio Core Network

Source: RAN WG4

Date: 3rd March 2000

Subject: Performance requirement

Work item:

Category:

(only one category shall be marked with an X)

F Correction
A Corresponds to a correction in an earlier release
B Addition of feature
C Functional modification of feature
D Editorial modification

Release:

Phase 2
Release 96
Release 97
Release 98
Release 99
Release 00

Reason for change:

The performance requirement were incomplete. This CR will update the missing specifications

Clauses affected: Section 8

Other specs affected:

Other 3G core specifications → List of CRs:
Other GSM core specifications → List of CRs:
MS test specifications → List of CRs:
BSS test specifications → List of CRs:
O&M specifications → List of CRs:

Other comments:



help.doc

<----- double-click here for help and instructions on how to create a CR.

8.4 Demodulation of DCH in moving propagation conditions

8.4.1 Single link performance

The receive single link performance of the Dedicated Traffic Channel (DCH) in dynamic moving propagation conditions are determined by the Block Error Rate (BLER) values. BLER is measured for the each of the individual data rate specified for the DPCH. DCH is mapped into Dedicated Physical Channel (DPCH).

8.4.1.1 Minimum requirement

For the parameters specified in Table 31 the BLER shall not exceed the piece-wise linear BLER curve specified in points in Table 32

Table 31: DCH parameters in moving propagation conditions

Parameter	Unit	Test 1	Test 2	Test 3
\hat{I}_{or}/I_{oc}	dB	-1		
I_{oc}	dBm/3.84 MHz	-60		
Information Data Rate	kbps	12.2	12.2	64
TFCI	-	off	on	on

Table 32: DCH requirements in moving propagation conditions

Test Number	$\frac{DPCH - E_c}{I_{or}}$	BLER
1		
<u>2</u>	<u>-154.5</u>	<u>10^{-2}</u>
<u>3</u>	<u>-10.9</u>	<u>10^{-2}</u>

8.5 Demodulation of DCH in birth-death propagation conditions

8.5.1 Single link performance

The receive single link performance of the Dedicated Traffic Channel (DCH) in dynamic birth-death propagation conditions are determined by the Block Error Rate (BLER) values. BER is measured for the each of the individual data rate specified for the DPCH. DCH is mapped into Dedicated Physical Channel (DPCH).

8.5.1.1 Minimum requirement

For the parameters specified in Table 33, the BLER shall not exceed the piece-wise linear BLER curve in the points in Table 34

Table 33: DCH parameters in birth-death propagation conditions

Parameter	Unit	Test 1	Test 2	Test 3
\hat{I}_{or}/I_{oc}	dB	-1		
I_{oc}	dBm/3.84 MHz	-60		
Information Data Rate	kbps	12.2	12.2	64
TFCI	-	off	on	on

Table 34: DCH requirements in birth-death propagation conditions

Test Number	$\frac{DPCH_E_c}{I_{or}}$	BLER
1		
2	<u>-12.86</u>	<u>10^{-2}</u>
3		<u>10^{-2}</u>

8.6 Demodulation of DCH in Base Station Transmit diversity modes

8.6.1 Demodulation of DCH in open-loop transmit diversity mode

The receive characteristic of the Dedicated Channel (DCH) in open loop transmit diversity mode is determined by the Block Error Rate (BLER). DCH is mapped into in Dedicated Physical Channel (DPCH)

8.6.1.1 Minimum requirement

For the parameters specified in Table 35 the BLER shall not exceed the associated piece-wise linear BLER curve specified by the points in Table 36

Table 35: Test parameters for DCH reception in an open loop transmit diversity scheme. (Propagation condition: Case 1)

Parameter	Unit	Test 1
\hat{I}_{or}/I_{oc}	dB	<u>-19dB</u>
I_{oc}	dBm/3.84 MHz	-60
Information data rate	kbps	12.2

Table 36: Test requirements for DCH reception in open loop transmit diversity scheme.

Test Number	$\frac{DPCH_E_c}{I_{or}}$ (antenna 1/2)	BLER
1	<u>-16.8</u>	<u>10^{-2}</u>

8.6.2 Demodulation of DCH in closed loop transmit diversity mode

The receive characteristic of the dedicated channel (DCH) in closed loop transmit diversity mode is determined by the Block Error Rate (BLER). DCH is mapped into in Dedicated Physical Channel (DPCH).

8.6.2.1 Minimum requirement

For the parameters specified in Table 37 the BLER shall not exceed the associated piece-wise linear BLER curves specified by the points in Table 38.

Table 37: Test Parameters for DCH Reception in closed loop transmit diversity mode (Propagation condition: Case 1)

Parameter	Unit	Test 1 (Mode 1)	Test 2 (Mode 2)
\hat{I}_{or}/I_{oc}	dB	<u>9dB</u>	<u>-9dB</u>
I_{oc}	dBm/3.84 MHz	-60	-60
Information data rate	kbps	12.2	12.2
Feedback error rate	%	4	4

Table 38: Test requirements for DCH reception in closed loop transmit diversity mode.

Test Number	$\frac{DPCH_E_c}{I_{or}}$ (2)	BLER
1	<u>-17.5</u>	<u>10^{-2}</u>
2	<u>-17.8</u>	<u>10^{-2}</u>

² This is the total power from both antennas. Power sharing between antennas are feedback mode dependent as specified in TS25.214

8.6.3 Demodulation of DCH in Site Selection Diversity Transmission mode

The bit error characteristics of UE receiver is determined in Site Selection Diversity Transmission (SSDT) mode. Two BS emulators are required for this performance test. The delay profiles of signals received from different base stations are assumed to be the same but time shifted by 10 chip periods (2604 ns).

8.6.3.1 Minimum Requirements

For the parameters specified in Table 39, the BLER shall not exceed the piece-wise linear BLER curve specified by the points in Table 41

Table 39: DCH parameters in multi-path propagation conditions during SSDT mode (Propagation condition: Case 1)

Parameter	Unit	Test 1	Test 2	Test 3	Test 4
$\frac{CPICH_E_c}{I_{or}}$ (for Cell 1)	dB	-10	-13	-10	-10
$\frac{CPICH_E_c}{I_{or}}$ (for Cell 2)	dB	-10	-10	-10	-13
$\frac{DPCH_E_{c1}}{I_{or}} / \frac{DPCH_E_{c2}}{I_{or}}$ *	dB	0	-3	0	+3
\hat{I}_{or1}/I_{oc}	dB	9	6	9	9
\hat{I}_{or2}/I_{oc}	dB	9	9	9	6
I_{oc}	dBm/3.84 MHz	-60			
Information Data Rate	kbps	12.2	12.2	12.2	12.2
Number of FBI bits assigned to "S" Field		1	1	2	2
Code word Set		Long	Long	Short	Short

*Note: DPCH_Ec/Ior value applies whenever DPDCH in the cell is transmitted

Table 41: DCH requirements in multi-path propagation conditions during SSDT Mode

Test Number	$\frac{DPCH_E_c}{I_{or}}$	BLER
1	-7.5	10^{-2}
2	-6.5	10^{-2}
3	-10.5	10^{-2}
4	-9.2	10^{-2}

8.7 Demodulation in Handover conditions

8.7.1 Inter-Cell Soft Handover Performance

The bit error rate characteristics of UE is determined during an inter-cell soft handover. During the soft handover a UE receives signals from different Base Stations. A UE has to be able to demodulate two PCCPCH channels and to combine the energy of DCH channels. Delay profiles of signals received from different Base Stations are assumed to be the same but time shifted by 10 chips.

The receive characteristics of the different channels during inter-cell handover are determined by the average Block Error Rate (BLER) values.

8.7.1.1 Minimum requirement

For the parameters specified in Table 42, the BLER shall not exceed the piece-wise linear BLER curve specified by the points in Table 43

Table 42: DCH parameters in multi-path propagation conditions during Soft Handoff (Case 3)

Parameter	Unit	Test 1	Test 2	Test 3	Test 4	Test 5
$\frac{DPCH_E_c}{I_{or}}$						
\hat{I}_{or1}/I_{oc} and \hat{I}_{or2}/I_{oc}	dB	0	0	0	3	6
I_{oc}	dBm/3.84 MHz					
Information data Rate	kbps	12.2	12.2	64	144	384
TFCI	-	off	on	on	on	on

Table 43: DCH requirements in multi-path propagation conditions during Soft Handoff (Case 3)

Test Number	$\frac{DPCH_E_c}{I_{or}}$	BLER
1	<u>[-16.3]</u>	<u>10^{-1}</u>
2	<u>[-15.2]</u>	<u>10^{-2}</u>
3	<u>[-11.8]</u>	<u>10^{-1}</u>
4	<u>[-11.3]</u>	<u>10^{-2}</u>
5	<u>[-9.6]</u>	<u>10^{-1}</u>
6	<u>[-9.2]</u>	<u>10^{-2}</u>
7	<u>[-6.0]</u>	<u>10^{-1}</u>
8	<u>[-5.5]</u>	<u>10^{-2}</u>

CHANGE REQUEST

Please see embedded help file at the bottom of this page for instructions on how to fill in this form correctly.

25.101 CR 034

Current Version: **3.1.0**

GSM (AA.BB) or 3G (AA.BBB) specification number ↑

↑ CR number as allocated by MCC support team

For submission to: **TSG RAN#7**
list expected approval meeting # here ↑

for approval
for information

strategic
non-strategic (for SMG use only)

Form: CR cover sheet, version 2 for 3GPP and SMG The latest version of this form is available from: <ftp://ftp.3gpp.org/Information/CR-Form-v2.doc>

Proposed change affects:
(at least one should be marked with an X)

(U)SIM ME UTRAN / Radio Core Network

Source: RAN WG4 **Date:** 2000/03/01

Subject: Power Control in downlink, constant BLER target

Work item:

Category:

(only one category shall be marked with an X)

F Correction
A Corresponds to a correction in an earlier release
B Addition of feature
C Functional modification of feature
D Editorial modification

Release: Phase 2
Release 96
Release 97
Release 98
Release 99
Release 00

Reason for change:

Inner loop and outer loop power control tests are combined based on the AH01 decision. The new name for a combined test will be "Power control in downlink, constant BLER target". This CR proposes several values for missing parameters/requirements in this test case.

Clauses affected: 8.8, 8.9

Other specs affected:

Other 3G core specifications → List of CRs:
Other GSM core specifications → List of CRs:
MS test specifications → List of CRs:
BSS test specifications → List of CRs:
O&M specifications → List of CRs:

Other comments:



help.doc

<----- double-click here for help and instructions on how to create a CR.

8.8 Inner loop power control in downlink

Performance of the inner loop power control in downlink is determined by the Block Error Rate (BLER) values and by the measured average transmitted $DPCH_{Ec}/I_{or}$ value.

8.8.1 Inner loop power control in the downlink

8.8.1.1 Minimum requirements

For the parameters specified in Table 44, the BLER and $DPCH_{Ec}/I_{or}$ value shall not exceed the values specified in Table 45.

Note

1. Power control is ON during the test.
2. Power control step size is 1 dB.

Table 44: Test parameters for downlink inner loop power control

Parameter	Unit	Test 1	Test 2
\hat{I}_{or}/I_{oc}	dB	9	-1
I_{oc}	dBm/3.84 MHz	-60	-60
Information Data Rate	kbps	12.2	12.2
TFCI	-	on	on
Propagation Conditions		Case 4	Case 4
SIR target		FFS	FFS

Table 45: Requirements in downlink inner loop power control

Parameter	Unit	Test 1	Test 2
$\frac{DPCH_{Ec}}{I_{or}}$	dB	FFS	FFS
BLER on TCH		0.01	0.01
Confidence level for $\frac{DPCH_{Ec}}{I_{or}}$	%		

8.89 Outer loop pPower control in downlink

Outer loop pPower control in the downlink is the ability of the UE receiver to converge to maintain the suitable target for the inner loop closed loop PC according to the required link quality set by the network while using as low power as possible in downlink. Additional performance requirements are expected to be added to this section.

8.89.1 Outer loop pPower control in the downlink, constant BLER target

8.89.1.1 Minimum requirements

For the parameters specified in Table 46 the downlink $\frac{DPCH_E_c}{I_{or}}$ power shall be below the specified value in table 47 and the reported quality measured BLER value shall be as shown required in table 47.

Note

1. Power control in downlink is ON during the test.
2. The averaging time T shall be long enough to minimize the previous quality target impact to the result.

Table 46: Test parameter for downlink outer loop power control

Parameter	Unit	Test 1	Test 2
\hat{I}_{or}/I_{oc}	dB	<u>95</u>	<u>-1</u>
I_{oc}	dBm/3.84 MHz	-60	
Information Data Rate	kbps	12.2	
TFCI	-	<u>On</u>	
<u>Reporting delay, or averaging period, T</u>	<u>ms</u>	<u>∞</u>	<u>∞</u>
<u>Target quality value on DTCH</u>	<u>BLER</u>	<u>0.01</u>	
Propagation condition		Case 4	

Table 47: Requirements in downlink outer loop power control

Parameter	Unit	Test 1	Test 2
$\frac{DPCH_E_c}{I_{or}}$	dB	<u>{-16.0max. needed channel power}</u>	<u>{-9.0max. needed channel power}</u>
<u>Target quality value</u>		<u>FFS</u>	<u>FFS</u>
<u>Reported quality value Measured quality on DTCH</u>	<u>BLER</u>	<u>FFS</u>	<u>FFS</u>
<u>Confidence level for measured quality and $\frac{DPCH_E_c}{I_{or}}$</u>	<u>%</u>	<u>90</u>	

CHANGE REQUEST

Please see embedded help file at the bottom of this page for instructions on how to fill in this form correctly.

25.101 CR 035

Current Version: **3.1.0**

GSM (AA.BB) or 3G (AA.BBB) specification number ↑

↑ CR number as allocated by MCC support team

For submission to:
list expected approval meeting # here ↑

for approval
for information

strategic
non-strategic (for SMG use only)

Form: CR cover sheet, version 2 for 3GPP and SMG The latest version of this form is available from: <ftp://ftp.3gpp.org/Information/CR-Form-v2.doc>

Proposed change affects: (U)SIM ME UTRAN / Radio Core Network
(at least one should be marked with an X)

Source: TSG RAN WG4 **Date:**

Subject: UE Minimum TX power change

Work item:

Category: F Correction **Release:** Phase 2
(only one category shall be marked with an X) A Corresponds to a correction in an earlier release Release 96
B Addition of feature Release 97
C Functional modification of feature Release 98
D Editorial modification Release 99
Release 00

Reason for change: UE minimum TX power is changed from -44 to -50 dBm. Other alignments to reflect this change.

Clauses affected: Section 6.4.3, 6.5.2, 7.9.1

Other specs affected: Other 3G core specifications → List of CRs:
Other GSM core specifications → List of CRs:
MS test specifications → List of CRs:
BSS test specifications → List of CRs:
O&M specifications → List of CRs:

Other comments:



help.doc

<----- double-click here for help and instructions on how to create a CR.

6.4.3 Minimum transmit output power

The minimum controlled output power of the UE is when the power control setting is set to a minimum value. This is when both the inner loop and open loop power control indicate a minimum transmit output power is required.

6.4.3.1 Minimum requirement

The minimum transmit power shall be better than $-44-50$ dBm measured with a filter that has a Root-Raised Cosine (RRC) filter response with a roll off $\alpha = 0.22$ and a bandwidth equal to the chip rate.

6.5 Transmit ON/OFF power

6.5.1 Transmit OFF power

The transmit OFF power state is when the UE does not transmit except during UL DTX mode. This parameter is defined as the maximum output transmit power within the channel bandwidth when the transmitter is OFF.

6.5.1.1 Minimum requirement

The requirement for the transmit OFF power shall be better than $-50-56$ dBm measured with a filter that has a Root-Raised Cosine (RRC) filter response with a roll off $\alpha = 0.22$ and a bandwidth equal to the chip rate

6.5.2 Transmit ON/OFF Time mask

The time mask for transmit ON/OFF defines the ramping time allowed for the UE between transmit OFF power and transmit ON power. Possible ON/OFF scenarios are RACH or UL slotted mode

6.5.2.1 Minimum requirement

The transmit power levels versus time should meet the mask specified in figure 1a

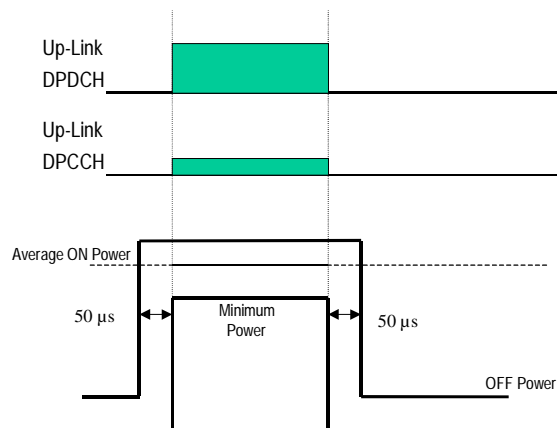

Figure 1a: Transmit ON/OFF template

7.9 Spurious emissions

The spurious emissions power is the power of emissions generated or amplified in a receiver that appear at the UE antenna connector.

7.9.1 Minimum requirement

The spurious emission shall be:

- (a) Less than -60 dBm/3.84 MHz at the UE antenna connector, for frequencies within the UE receive band. In URA_PCH-, Cell_PCH- and IDLE- stage the requirement applies also for UE transmit band.
- (b) Less than -57 dBm/100 kHz at the UE antenna connector, for frequencies band from 9 kHz to 1 GHz.
- (c) Less than -47 dBm/100 kHz at the UE antenna connector, for frequencies band from 1 GHz to 12.75 GHz.

CHANGE REQUEST

Please see embedded help file at the bottom of this page for instructions on how to fill in this form correctly.

25.101 CR 036

Current Version: **3.1.0**

GSM (AA.BB) or 3G (AA.BBB) specification number ↑

↑ CR number as allocated by MCC support team

For submission to: **RAN#7**

List expected approval meeting # here



for approval

For information

X

strategic

non-strategic

(for SMG use only)

Form: CR cover sheet, version 2 for 3GPP and SMG The latest version of this form is available from: <ftp://ftp.3gpp.org/Information/CR-Form-v2.doc>

Proposed change affects:

(at least one should be marked with an X)

(U)SIM

ME

UTRAN / Radio

Core Network

Source:

RAN WG4

Date:

1/3/99

Subject:

Performance requirements for demodulation of DCH in Site Selection Diversity Transmission mode for Section 8.6.3 of 25.101v3.1.0

Work item:

Category:

(only one category
Shall be marked
With an X)

- F Correction
- A Corresponds to a correction in an earlier release
- B Addition of feature
- C Functional modification of feature
- D Editorial modification

Release:

- Phase 2
- Release 96
- Release 97
- Release 98
- Release 99
- Release 00

Reason for change:

This contribution completes Table 41, performance requirements for demodulation of DCH in Site Selection Diversity Transmission mode.

Clauses affected:

Other specs

Affected:

- Other 3G core specifications → List of CRs:
- Other GSM core specifications → List of CRs:
- MS test specifications → List of CRs:
- BSS test specifications → List of CRs:
- O&M specifications → List of CRs:

Other comments:

1. Text proposal for chapter 8.6.3

8.6.3 Demodulation of DCH in Site Selection Diversity Transmission Power Control mode

The bit error characteristics of UE receiver is determined in Site Selection Diversity Transmission power control (SSDT) mode. Two BS emulators are required for this performance test. The delay profiles of signals received from different base stations are assumed to be the same but time shifted by 10 chip periods (2604 ns).

8.6.3.1 Minimum Requirements

DCH parameters are specified in Table 39. The downlink physical channels and their relative power to I_{or} are the same as those specified in Annex C.3 irrespective of BSs and the test cases. In Test 1 and Test 3, the received powers at UE from two BSs are the same, while 3dB offset is given to one that comes from one of BSs for Test 2 and Test 4 as specified in Table 39. For the parameters specified in Table 39, the BLER shall not exceed the value at the DPCH E_c/I_{or} specified in Table 41. ~~the piece-wise linear BLER curve specified by the points in Table 41~~

**Table 39: DCH parameters in multi-path propagation conditions during SSDT mode
(Propagation condition: Case 1)**

Parameter	Unit	Test 1	Test 2	Test 3	Test 4
$\frac{CPICH - E_c}{I_{or}}$ (for Cell 1)	dB	-10	-13	-10	-10
$\frac{CPICH - E_c}{I_{or}}$ (for Cell 2)	dB	-10	-10	-10	-13
$\frac{DPCH - E_{c1}}{I_{or}} / \frac{DPCH - E_{c2}}{I_{or}}^*$	dB	0	-3	0	+3
\hat{I}_{or1}/I_{oc}	dB	<u>90</u>	<u>6-3</u>	<u>90</u>	<u>90</u>
\hat{I}_{or2}/I_{oc}	dB	<u>90</u>	<u>90</u>	<u>90</u>	<u>6-3</u>
I_{oc}	dBm/3.84 MHz	-60			
Information Data Rate	kbps	12.2	12.2	12.2	12.2
Number of FBI bits assigned to "S" Field		1	1	2	2
Code word Set		Long	Long	Short	Short

*Note: DPCH E_c/I_{or} value applies whenever DPDCH in the cell is transmitted

Table 41: DCH requirements in multi-path propagation conditions during SSDT Mode

Test Number	$\frac{DPCH_E_c}{I_{or}}$	BLER
1		10^{-1}
	<u>-7.5</u>	10^{-2}
2		10^{-1}
	<u>-6.5</u>	10^{-2}
3		10^{-1}
	<u>-10.5</u>	10^{-2}
4		10^{-1}
	<u>-9.2</u>	10^{-2}

CHANGE REQUEST

Please see embedded help file at the bottom of this page for instructions on how to fill in this form correctly.

25.101 CR 037

Current Version: **3.1.0**

GSM (AA.BB) or 3G (AA.BBB) specification number ↑

↑ CR number as allocated by MCC support team

For submission to: **TSG RAN #7**
list expected approval meeting # here ↑

For approval for information

strategic (for SMG use only)
non-strategic

Form: CR cover sheet, version 2 for 3GPP and SMG The latest version of this form is available from: <ftp://ftp.3gpp.org/Information/CR-Form-v2.doc>

Proposed change affects:
(at least one should be marked with an X)

(U)SIM ME UTRAN / Radio Core Network

Source: RAN WG4

Date: 2000-01-18

Subject: Reference compressed mode patterns

Work item: UTRA

Category:

(only one category shall be marked with an X)

F Correction
A Corresponds to a correction in an earlier release
B Addition of feature
C Functional modification of feature
D Editorial modification

Release:

Phase 2
Release 96
Release 97
Release 98
Release 99
Release 00

Reason for change:

Include reference compressed mode patterns to define performance requirements for both radio link performance and measurements.

Clauses affected: Annex A.4

Other specs affected:

Other 3G core specifications → List of CRs:
Other GSM core specifications → List of CRs:
MS test specifications → List of CRs:
BSS test specifications → List of CRs:
O&M specifications → List of CRs:

Other comments:

Based on discussions in RAN4, to include reference compressed mode patterns for performance requirements in TS25.101 and TS25.133



help.doc

<----- double-click here for help and instructions on how to create a CR.

A.4 DL reference compressed mode parameters

Table A.4.1: compressed mode reference pattern 1 parameters

<u>Parameter</u>	<u>1.1</u>	<u>1.2</u>	<u>Note</u>
<u>TGSN (Transmission Gap Starting Slot Number)</u>	<u>11</u>	<u>11</u>	
<u>TGL1 (Transmission Gap Length 1)</u>	<u>7</u>	<u>7</u>	
<u>TGL2 (Transmission Gap Length 2)</u>	-	-	<u>Only one gap in use.</u>
<u>TGD (Transmission Gap Distance)</u>	-	-	<u>Only one gap in use.</u>
<u>TGPL1 (Transmission Gap Pattern Length)</u>	<u>2</u>	<u>4</u>	
<u>TGPL2 (Transmission Gap Pattern Length)</u>	-	-	<u>Only one pattern in use.</u>
<u>TGPRC (Transmission Gap Pattern Repetition Count)</u>	<u>NA</u>	<u>NA</u>	<u>Defined by higher layers</u>
<u>TGCFN (Transmission Gap Connection Frame Number):</u>	<u>NA</u>	<u>NA</u>	<u>Defined by higher layers</u>
<u>UL/DL compressed mode selection</u>	<u>DL & UL</u>	<u>DL & UL</u>	<u>2 configurations possible</u> <u>DL&UL / DL</u>
<u>UL compressed mode method</u>	<u>SF/2</u>	<u>SF/2</u>	
<u>DL compressed mode method</u>	<u>SF/2</u>	<u>Puncturing</u>	
<u>Downlink frame type and Slot format</u>	<u>11B</u>	<u>11A</u>	
<u>Scrambling code change</u>	<u>No</u>	<u>No</u>	
<u>RPP (Recovery period power control mode)</u>	<u>0</u>	<u>0</u>	
<u>ITP (Initial transmission power control mode)</u>	<u>0</u>	<u>0</u>	

Table A.4.2: compressed mode reference pattern 2 parameters

<u>Parameter</u>	<u>2.1</u>	<u>2.2</u>	<u>Note</u>
<u>TGSN (Transmission Gap Starting Slot Number)</u>	<u>4</u>	<u>4</u>	
<u>TGL1 (Transmission Gap Length 1)</u>	<u>7</u>	<u>7</u>	
<u>TGL2 (Transmission Gap Length 2)</u>	-	-	<u>Only one gap in use.</u>
<u>TGD (Transmission Gap Distance)</u>	-	<u>135</u>	
<u>TGPL1 (Transmission Gap Pattern Length)</u>	<u>3</u>	<u>12</u>	
<u>TGPL2 (Transmission Gap Pattern Length)</u>	-	-	<u>Only one pattern in use.</u>
<u>TGPRC (Transmission Gap Pattern Repetition Count)</u>	<u>NA</u>	<u>NA</u>	<u>Defined by higher layers</u>
<u>TGCFN (Transmission Gap Connection Frame Number):</u>	<u>NA</u>	<u>NA</u>	<u>Defined by higher layers</u>
<u>UL/DL compressed mode selection</u>	<u>DL & UL</u>	<u>DL & UL</u>	<u>2 configurations possible.</u> <u>DL&UL / DL</u>
<u>UL compressed mode method</u>	<u>SF/2</u>	<u>SF/2</u>	
<u>DL compressed mode method</u>	<u>SF/2</u>	<u>SF/2</u>	
<u>Downlink frame type and Slot format</u>	<u>11B</u>	<u>11B</u>	
<u>Scrambling code change</u>	<u>No</u>	<u>No</u>	
<u>RPP (Recovery period power control mode)</u>	<u>0</u>	<u>0</u>	
<u>ITP (Initial transmission power control mode)</u>	<u>0</u>	<u>0</u>	

The following parameters characterise the transmission gap :

~~TGL: 7~~

~~SFN: FFS~~

~~SN: FFS~~

~~The following parameters characterise the compressed mode pattern:~~

~~TGP: FFS~~

~~TGL: 7~~

~~TGD: FFS~~

~~PD: FFS~~

~~SFN: FFS~~

~~PCM: FFS~~

~~Transmission time reduction method FFS~~

CHANGE REQUEST

Please see embedded help file at the bottom of this page for instructions on how to fill in this form correctly.

25.101 CR 038

Current Version: **3.1.0**

GSM (AA.BB) or 3G (AA.BBB) specification number ↑

↑ CR number as allocated by MCC support team

For submission to: **RAN #7**
list expected approval meeting # here ↑

for approval
for information

strategic
non-strategic (for SMG use only)

Form: CR cover sheet, version 2 for 3GPP and SMG The latest version of this form is available from: ftp://ftp.3gpp.org/Information/CR-Form-v2.doc

Proposed change affects: (U)SIM ME UTRAN / Radio Core Network
(at least one should be marked with an X)

Source: RAN WG4 **Date:** 1 Mar 2000

Subject: 384kbps measurement channel is replaced with 10ms TTI

Work item: TS25.101

Category: F Correction **Release:** Phase 2
 (only one category shall be marked with an X) A Corresponds to a correction in an earlier release Release 96
 B Addition of feature Release 97
 C Functional modification of feature Release 98
 D Editorial modification Release 99
 Release 00

Reason for change: 10ms-TTI should be used for 384kbps measurement channel to reduce complexity for performance tests. So a note "384kbps performance requirement will be replaced with 10ms-TTI" is added by each 384kpsps result. Also the new definition of the 10ms-TTI measurement channel and a note "20ms-TTI measurement channel will be removed" is added.

Clauses affected: 8.2.3, 8.3.1, Annex A

Other specs affected: Other 3G core specifications → List of CRs:
 Other GSM core specifications → List of CRs:
 MS test specifications → List of CRs:
 BSS test specifications → List of CRs:
 O&M specifications → List of CRs:

Other comments:

<----- double-click here for help and instructions on how to create a CR.

8.2.3 Demodulation of Dedicated Channel (DCH)

The receive characteristic of the Dedicated Channel (DCH) in the static environment is determined by the Block Error Rate (BLER). BLER is specified for each individual data rate of the DCH. DCH is mapped into the Dedicated Physical Channel (DPCH).

8.2.3.1 Minimum requirement

For the parameters specified in Table 23 the BLER shall not exceed the piece-wise linear BLER curve specified by the points in table 24

Note: The performance requirements for 384kbps will be replaced with new value using 10ms TTI measurement channel defined in Annex A3.5.

Table 23: DCH parameters in static propagation conditions

Parameter	Unit	Test 1	Test 2	Test 3	Test 4	Test 5
\hat{I}_{or}/I_{oc}	dB	-1				
I_{oc}	dBm/3.84 MHz	-60				
Information Data Rate	kbps	12.2	12.2	64	144	384
TFCI	-	off	on	on	on	on

Table 24: DCH requirements in static propagation conditions

Test Number	$\frac{DPCH_E_c}{I_{or}}$	BLER
1		10^{-2}
2	-16.6 dB	10^{-2}
3	-13.1 dB	10^{-1}
	-12.8 dB	10^{-2}
4	-9.9 dB	10^{-1}
	-9.8 dB	10^{-2}
5	-5.6 dB	10^{-1}
	-5.5 dB	10^{-2}

8.3 Demodulation of DCH in multi-path fading propagation conditions

8.3.1 Single Link Performance

The receive characteristics of the Dedicated Channel (DCH) in different multi-path fading environments are determined by the Block Error Rate (BLER) values. BLER is measured for the each of the individual data rate specified for the DPCH. DCH is mapped into in Dedicated Physical Channel (DPCH).

8.3.1.1 Minimum requirement

For the parameters specified in Table 25, 27 and 29 the BLER shall not exceed the associated piece-wise linear BLER curves specified by the points in Table 26, 28 and 30

Note: The performance requirements for 384kbps will be replaced with new value using 10ms TTI measurement channel defined in Annex A3.5.

Table 25: Test Parameters for DCH in multi-path fading propagation conditions (Case 1)

Parameter	Unit	Test 1	Test 2	Test 3	Test 4	Test 5
\hat{I}_{or}/I_{oc}	dB	9				
I_{oc}	dBm/3.84 MHz	-60				
Information Data Rate	kbps	12.2	12.2	64	144	384
TFCI	-	off	on	on	on	on

Table 26: Test requirements for DCH in multi-path fading propagation conditions (Case 1)

Test Number	$\frac{DPCH_E_c}{I_{or}}$	BLER
1		10^{-2}
2	-15.0 dB	10^{-2}
3	-13.9 dB	10^{-1}
	-10.0 dB	10^{-2}
4	-10.6 dB	10^{-1}
	-6.8 dB	10^{-2}
5	-6.3 dB	10^{-1}
	-2.2 dB	10^{-2}

Table 27: DCH parameters in multi-path fading propagation conditions (Case 2)

Parameter	Unit	Test 6	Test 7	Test 8	Test 9	Test 10
\hat{I}_{or}/I_{oc}	dB	-3	-3	-3	3	6
I_{oc}	dBm/3.84 MHz	-60				
Information Data Rate	kbps	12.2	12.2	64	144	384
TFCI	-	off	on	on	on	on

Table 28: DCH requirements in multi-path fading propagation (Case 2)

Test Number	$\frac{DPCH_E_c}{I_{or}}$	BLER
6		10^{-2}
7	-7.7 dB	10^{-2}
8	-6.4 dB	10^{-1}
	-2.7 dB	10^{-2}
9	-8.1 dB	10^{-1}
	-5.1 dB	10^{-2}
10	-5.5 dB	10^{-1}
	-3.2 dB	10^{-2}

Table 29: DCH parameters in multi-path fading propagation conditions (Case 3)

Parameter	Unit	Test 11	Test 12	Test 13	Test 14	Test 15
\hat{I}_{or}/I_{oc}	dB	-3	-3	-3	3	6
I_{oc}	dBm/3.84 MHz	-60				
Information Data Rate	kbps	12.2	12.2	64	144	384
TFCI	-	off	on	on	on	on

Table 30: DCH requirements in multi-path fading propagation conditions (Case 3)

Test Number	$\frac{DPCH - E_c}{I_{or}}$	BLER
11		10^{-2}
12	-11.8 dB	10^{-2}
13	-8.1 dB	10^{-1}
	-7.4 dB	10^{-2}
	-6.8 dB	10^{-3}
14	-9.0 dB	10^{-1}
	-8.5 dB	10^{-2}
	-8.0 dB	10^{-3}
15	-6.0 dB	10^{-1}
	-5.5 dB	10^{-2}
	-5.0 dB	10^{-3}

Annex A (normative): Measurement channels

A.1 General

The measurement channels in this annex are defined to derive the requirements in section 6, 7 and 8. The measurement channels represent example configuration of radio access bearers for different data rates.

The measurement channel for 12.2 kbps shall be supported by any UE both in up- and downlink. Support for other measurement channels is depending on the UE Radio Access capabilities.

A.2 UL reference measurement channel

A.2.1 UL reference measurement channel (12.2 kbps)

The parameters for the 12.2 kbps UL reference measurement channel are specified in Table A.1 and Table A.2. The channel coding for information is shown in figure A.1

Table A.1: UL reference measurement channel physical parameters (12.2 kbps)

Parameter	Unit	Level
Information bit rate	kbps	12.2
DPDCH	kbps	60
DPCCH	kbps	15
DPCCH/DPDCH	dB	-6
TFCI	-	On
Repetition	%	23

Table A.2: UL reference measurement channel, transport channel parameters (12.2 kbps)

Parameters	DCCH	DTCH
Transport Channel Number	1 (TBD by WG2)	2 (TBD by WG2)
Transport Block Size	96	244
Transport Block Set Size	96	244
Transmission Time Interval	40 ms	20 ms
Type of Error Protection	Convolution Coding	Convolution Coding
Coding Rate	1/3	1/3
Static Rate Matching parameter	1.0	1.0
Size of CRC	16	16
Position of TrCH in radio frame	Fixed	fixed

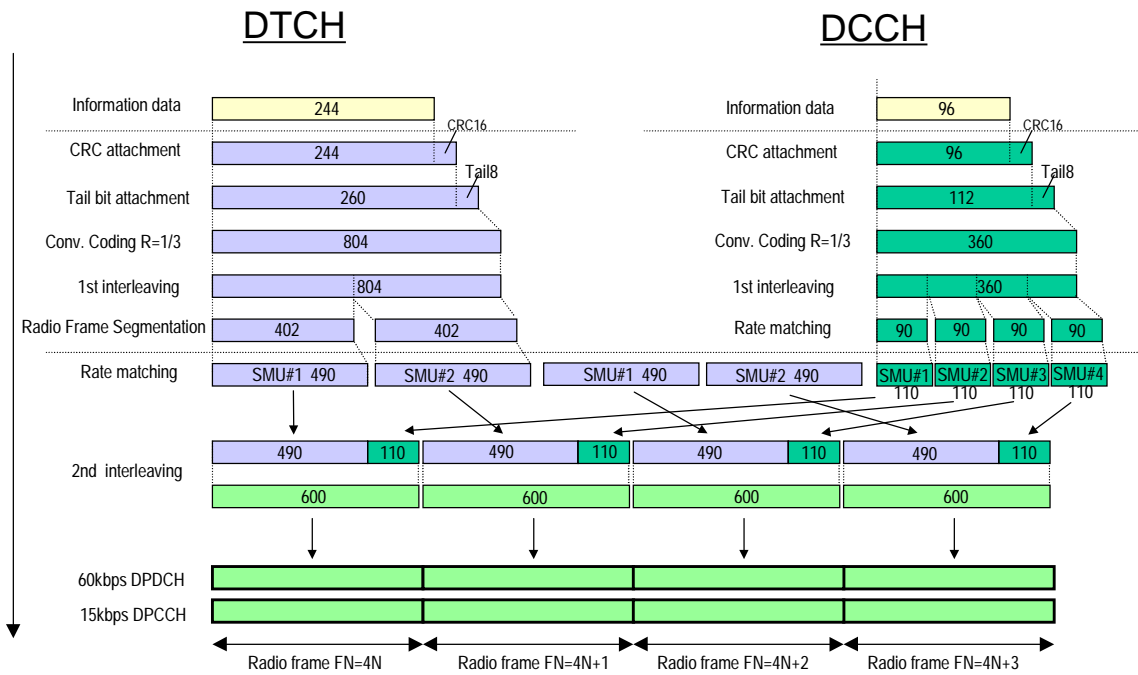

Figure A.1(Informative): Channel coding of UL reference measurement channel (12.2 kbps)

A.2.2 UL reference measurement channel (64 kbps)

The parameters for the 64 kbps UL reference measurement channel are specified in Table A.3 and Table A.4. The channel coding for information is shown in figure A.2. This measurement channel is not currently used in TS25.101 but can be used for future requirements.

Table A.3: UL reference measurement channel (64 kbps)

Parameter	Unit	Level
Information bit rate	kbps	64
DPDCH	kbps	240
DPCCH	kbps	15
DPCCH/DPDCH	dB	-9
TFCI	-	On
Repetition	%	18

Table A.4: UL reference measurement channel, transport channel parameters (64kbps)

Parameter	DCCH	DTCH
Transport Channel Number	1 (TBD by WG2)	2 (TBD by WG2)
Transport Block Size	96	1280
Transport Block Set Size	96	1280
Transmission Time Interval	40 ms	20 ms
Type of Error Protection	Convolution Coding	Turbo Coding
Coding Rate	1/3	1/3
Static Rate Matching parameter	1.0	1.0

Size of CRC	16	16
Position of TrCH in radio frame	Fixed	Fixed

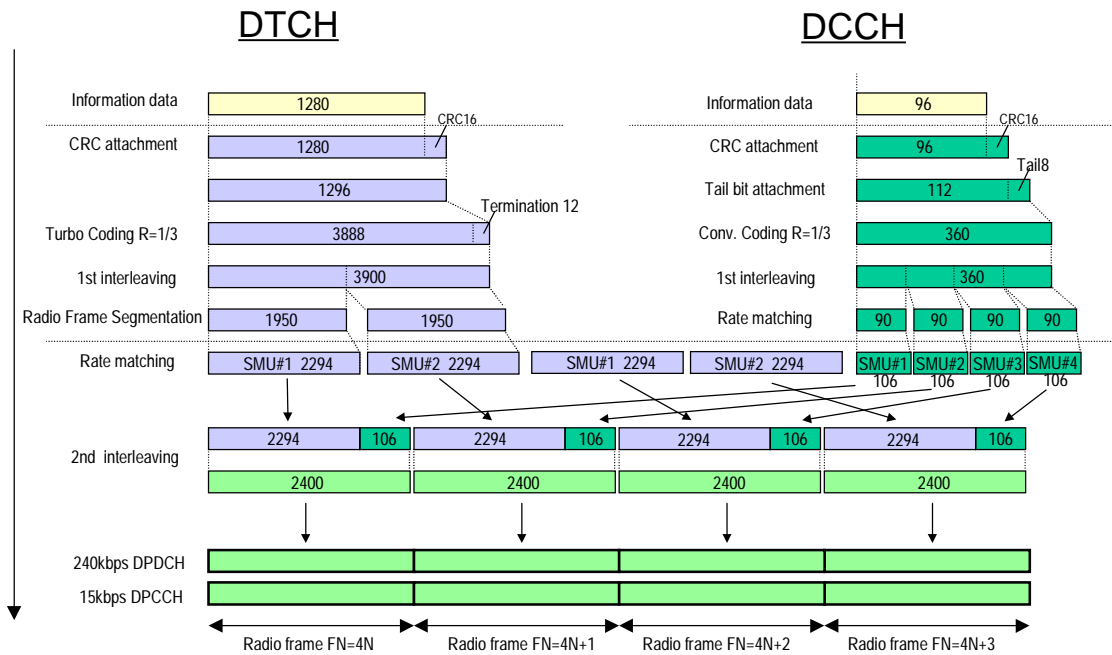

Figure A.2 (Informative): Channel coding of UL reference measurement channel (64 kbps)

A.2.3 UL reference measurement channel (144 kbps)

The parameters for the 144 kbps UL reference measurement channel are specified in Table A.5 and Table A.6. The channel coding for information is shown in Figure A.3. This measurement channel is not currently used in TS25.101 but can be used for future requirements.

Table A.5: UL reference measurement channel (144 kbps)

Parameter	Unit	Level
Information bit rate	kbps	144
DPDCH	kbps	480
DPCCH	kbps	15
DPCCH/DPDCH	dB	-12
TFCI	-	On
Repetition	%	8

Table A.6: UL reference measurement channel, transport channel parameters (144kbps)

Parameters	DCCH	DTCH
Transport Channel Number	1 (TBD by WG2)	2 (TBD by WG2)
Transport Block Size	96	2880
Transport Block Set Size	96	2880
Transmission Time Interval	40 ms	20 ms

Type of Error Protection	Convolution Coding	Turbo Coding
Coding Rate	1/3	1/3
Static Rate Matching parameter	1.0	1.0
Size of CRC	16	16
Position of TrCH in radio frame	Fixed	Fixed

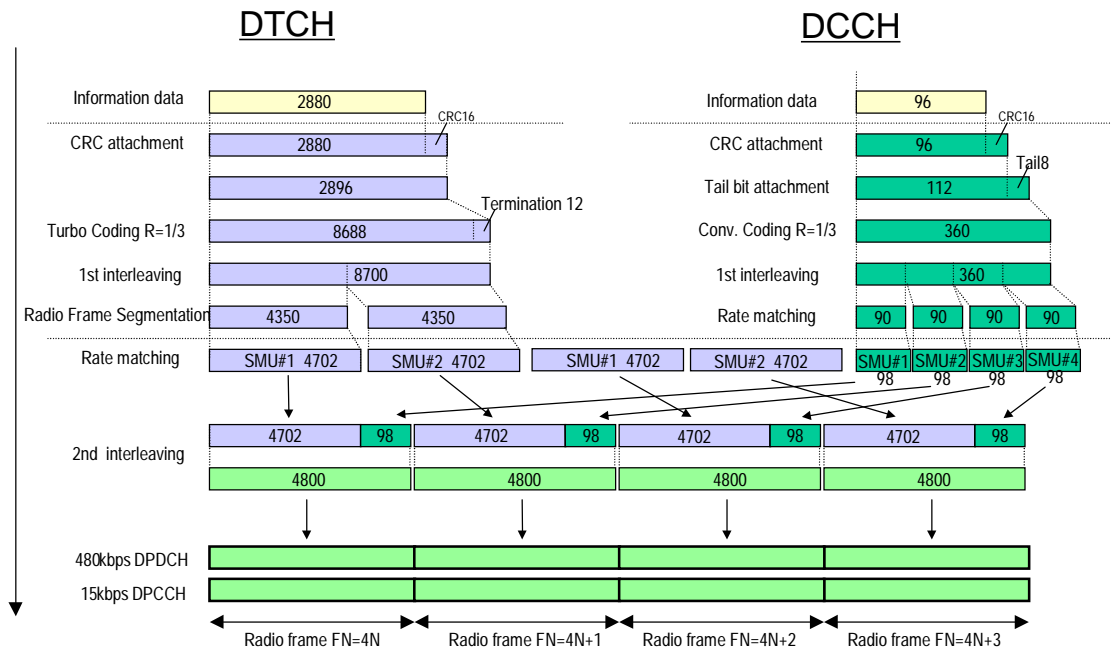

Figure A.3 (Informative): Channel coding of UL reference measurement channel (144 kbps)

A.2.4 UL reference measurement channel (384 kbps)

The parameters for the 384 kbps-UL reference measurement channel (TTI=20ms) are specified in Table A.7 and Table A.8. The channel coding for information is shown in Figure A.4. This measurement channel is not currently used in TS25.101 but can be used for future requirements.

Note: The measurement channel for 384kbps with 20ms-TTI will be deleted, and new 384kbps measurement channel defined in Annex A3.5 will be used.

Table A.7: UL reference measurement channel (384 kbps)

Parameter	Unit	Level
Information bit rate	kbps	384
DPDCH	kbps	960
DPCCH	kbps	15
DPCCH/DPDCH	dB	-12
TFCI	-	On
Puncturing	%	18

Table A.8: UL reference measurement channel, transport channel parameters (384 kbps)

Parameter	DCCH	DTCH
Transport Channel Number	1 (TBD by WG2)	2 (TBD by WG2)
Transport Block Size	96	3840
Transport Block Set Size	96	7680
Transmission Time Interval	40 ms	20 ms
Type of Error Protection	Convolution Coding	Turbo Coding
Coding Rate	1/3	1/3
Static Rate Matching parameter	1.0	1.0
Size of CRC	16	16
Position of TrCH in radio frame	Fixed	Fixed

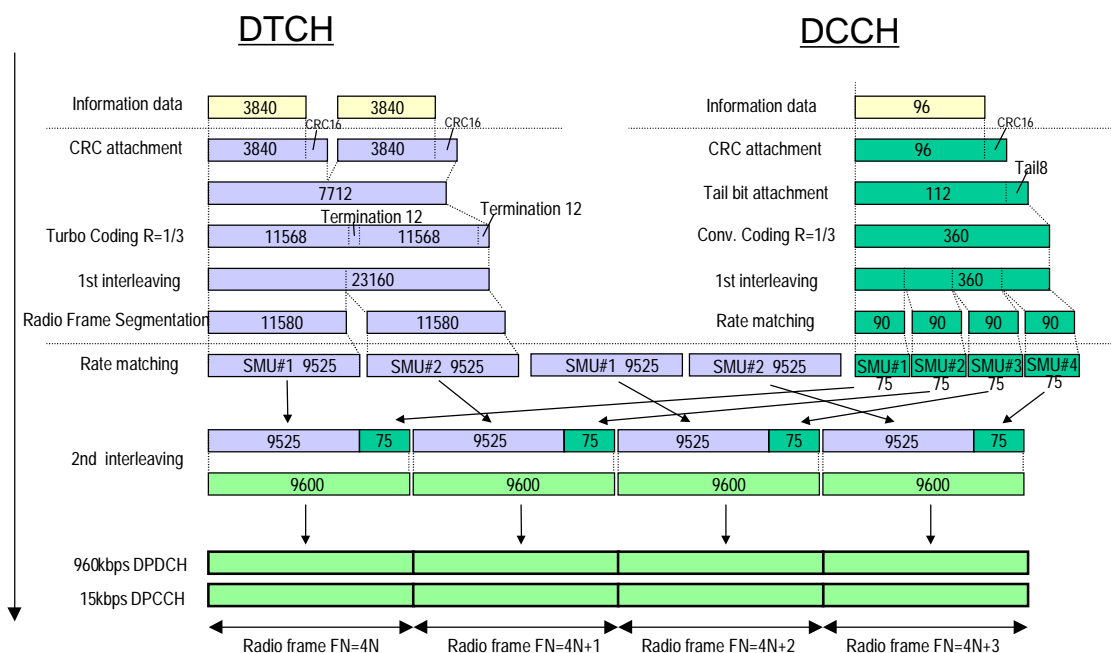

Figure A.4 (Informative): Channel coding of UL reference measurement channel (384 kbps)

A.2.5 UL reference measurement channel (384 kbps)

The parameters for the 384 kbps UL reference measurement channel are specified in Table A.x and Table A.x. The channel coding for information is shown in Figure A.4. This measurement channel is not currently used in TS25.101 but can be used for future requirements.

Table A.x: UL reference measurement channel (384 kbps)

Parameter	Unit	Level
Information bit rate	kbps	384

<u>DPDCH</u>	<u>kbps</u>	<u>960</u>
<u>DPCCH</u>	<u>kbps</u>	<u>15</u>
<u>DPCCH/DPDCH power ratio</u>	<u>dB</u>	<u>-11.48</u>
<u>TFCI</u>	<u>-</u>	<u>On</u>
<u>Puncturing</u>	<u>%</u>	<u>18</u>

Table A.x: UL reference measurement channel, transport channel parameters (384 kbps)

<u>Parameter</u>	<u>DTCH</u>	<u>DCCH</u>
<u>Transport Channel Number</u>	<u>1</u>	<u>2</u>
<u>Transport Block Size</u>	<u>3840</u>	<u>100</u>
<u>Transport Block Set Size</u>	<u>3840</u>	<u>100</u>
<u>Transmission Time Interval</u>	<u>10 ms</u>	<u>40 ms</u>
<u>Type of Error Protection</u>	<u>Turbo Coding</u>	<u>Convolution Coding</u>
<u>Coding Rate</u>	<u>1/3</u>	<u>1/3</u>
<u>Static Rate Matching parameter</u>	<u>1.0</u>	<u>1.0</u>
<u>Size of CRC</u>	<u>16</u>	<u>12</u>

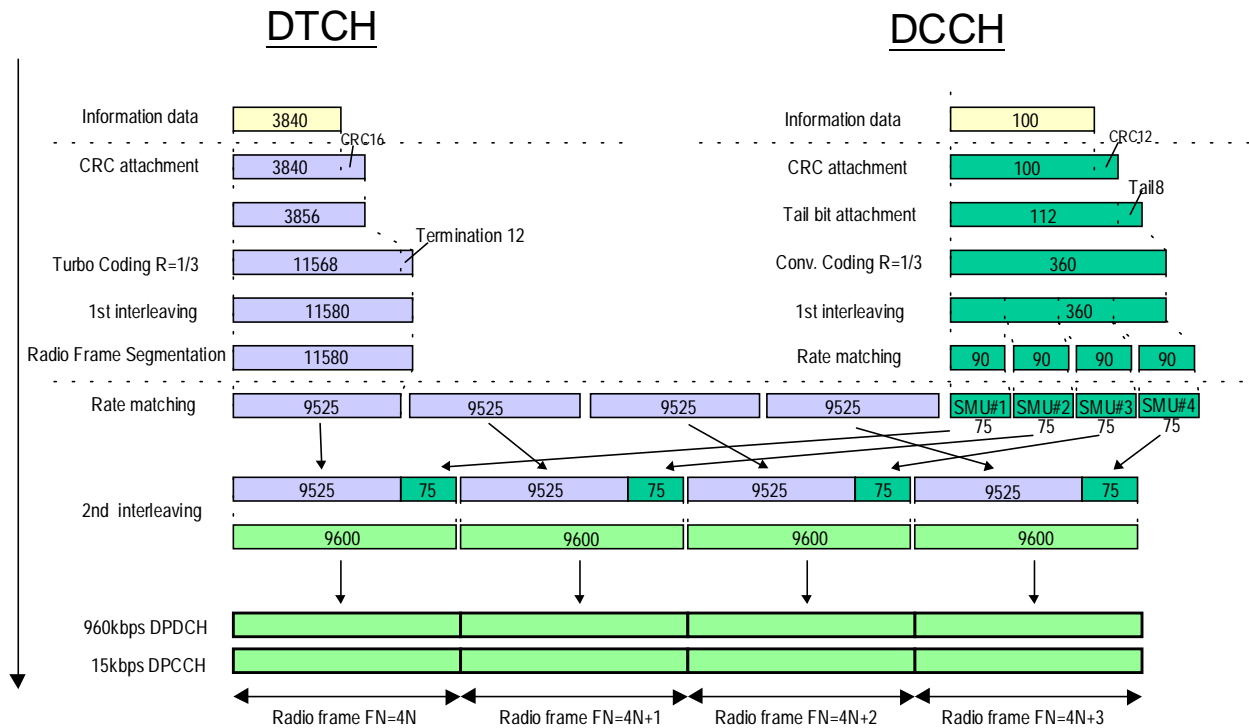

Figure A.x (Informative): Channel coding of UL reference measurement channel (384 kbps)

A.3 DL reference measurement channel

A.3.1 DL reference measurement channel (12.2 kbps)

The parameters for the 12.2 Kbps DL reference measurement channel are specified in Table A. 9 and Table A.10. The channel coding is shown for information in figure A.5

Table A.9: DL reference measurement channel physical parameters (12.2 kbps)

Parameter	Unit	Level
Information bit rate	kbps	12.2
DPCH	ksps	30
TFCI	-	On
Puncturing	%	14.5

Table A.10: DL reference measurement channel, transport channel parameters (12.2 kbps)

Parameter	DCCH	DTCH
Transport Channel Number	1 (TBD by WG2)	2 (TBD by WG2)
Transport Block Size	96	244
Transport Block Set Size	96	244
Transmission Time Interval	40 ms	20 ms
Type of Error Protection	Convolution Coding	Convolution Coding
Coding Rate	1/3	1/3
Static Rate Matching parameter	1.0	1.0
Size of CRC	16	16
Position of TrCH in radio frame	fixed	fixed

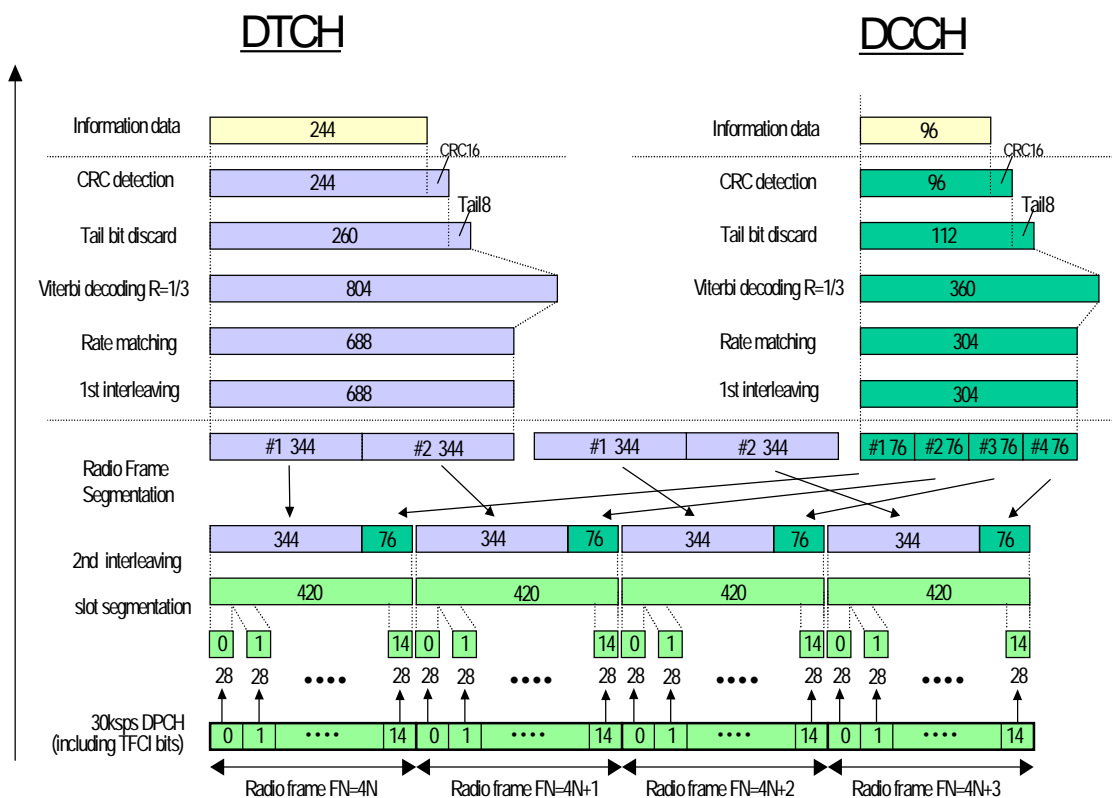

Figure A.5 (Informative): Channel coding of DL reference measurement channel (12.2 kbps)

A.3.2 DL reference measurement channel (64 kbps)

The parameters for the DL reference measurement channel for 64 kbps are specified in Table A.11 and Table A.12. The channel coding is shown for information in Figure A.6

Table A.11: DL reference measurement channel physical parameters (64 kbps)

Parameter	Unit	Level
Information bit rate	kbps	64
DPCH	ksps	120
TFCI	-	On
Repetition	%	2.9

Table A.12: DL reference measurement channel, transport channel parameters (64 kbps)

Parameter	DCCH	DTCH
Transport Channel Number	1 (TBD by WG2)	2 (TBD by WG2)
Transport Block Size	96	1280
Transport Block Set Size	96	1280
Transmission Time Interval	40 ms	20 ms
Type of Error Protection	Convolution Coding	Turbo Coding
Coding Rate	1/3	1/3
Static Rate Matching parameter	1.0	1.0

Size of CRC	16	16
Position of TrCH in radio frame	fixed	fixed

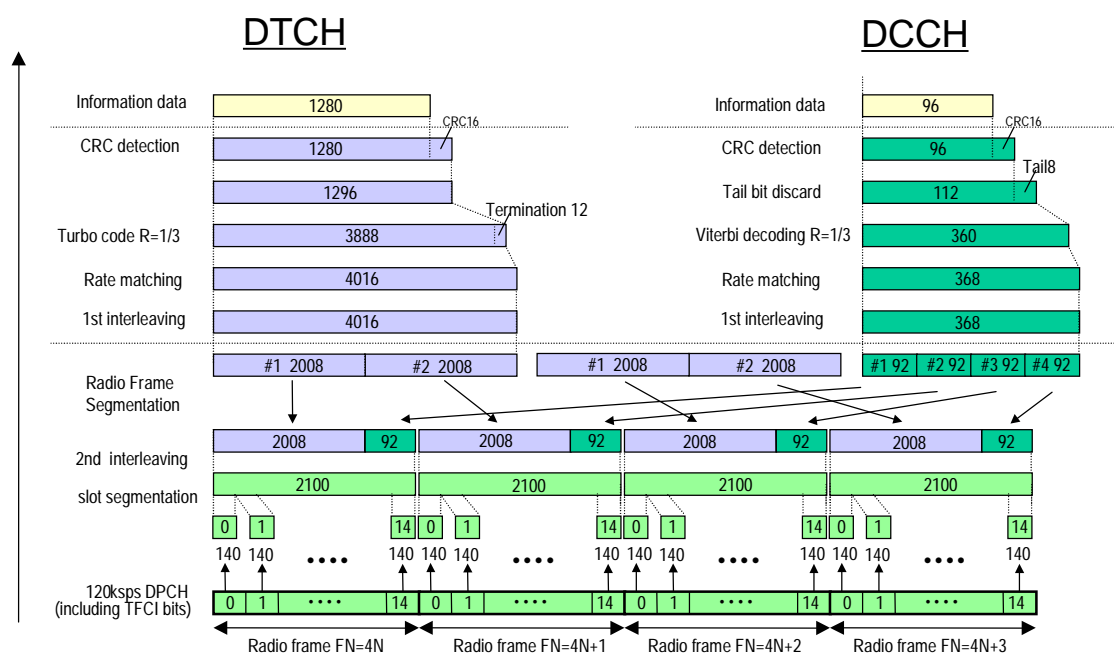

Figure A.6 (Informative): Channel coding of DL reference measurement channel (64 kbps)

A.3.3 DL reference measurement channel (144 kbps)

The parameters for the DL measurement channel for 144 kbps are specified in Table A.13 and Table A.14. The channel coding is shown for information in Figure A.7

Table A.13: DL reference measurement channel physical parameters (144 kbps)

Parameter	Unit	Level
Information bit rate	kbps	144
DPCH	ksps	240
TFCI	-	On
Puncturing	%	2.7

Table A.14: DL reference measurement channel, transport channel parameters (144 kbps)

Parameter	DCCH	DTCH
Transport Channel Number	1 (TBD by WG2)	2 (TBD by WG2)
Transport Block Size	96	2880
Transport Block Set Size	96	2880
Transmission Time Interval	40 ms	20 ms

Type of Error Protection	Convolution Coding	Turbo Coding
Coding Rate	1/3	1/3
Static Rate Matching parameter	1.0	1.0
Size of CRC	16	16
Position of TrCH in radio frame	fixed	fixed

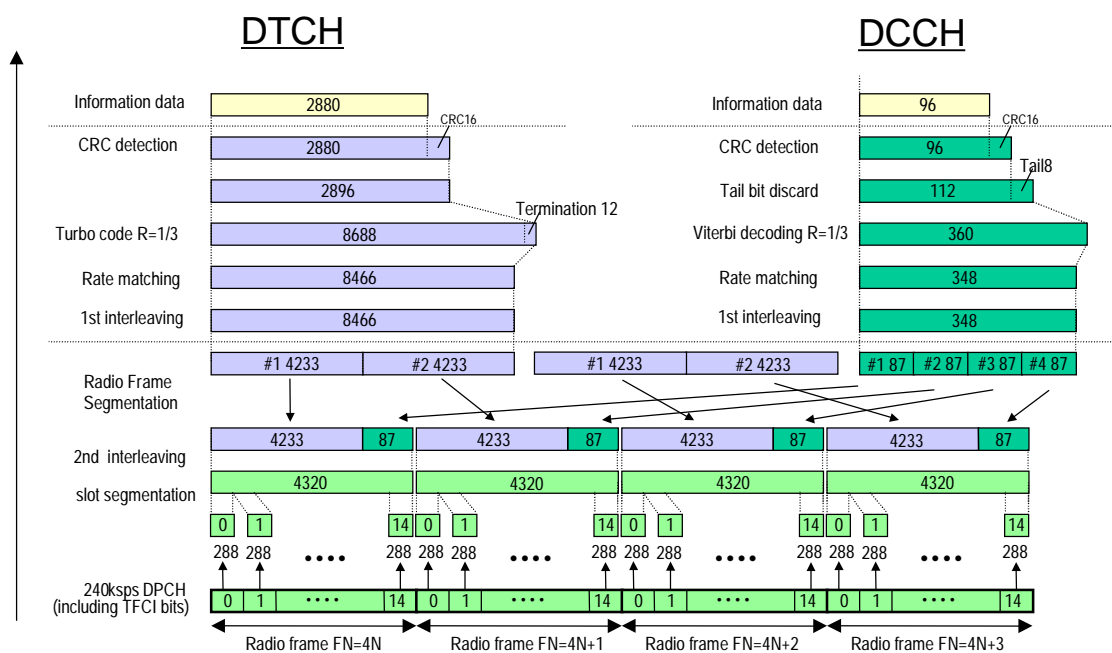

Figure A.7 (Informative): Channel coding of DL reference measurement channel (144 kbps)

A.3.4 DL reference measurement channel (384 kbps)

The parameters for the DL measurement channel for 384 kbps (20ms-TTI) are specified in Table A.15 and Table A.16. The channel coding is shown for information in Figure A.8

Note: The measurement channel for 384kbps with 20ms-TTI will be deleted, and new 384kbps measurement channel defined in Annex A3.5 will be used.

Table A.15: DL reference measurement channel, physical parameters (384 kbps)

Parameter	Unit	Level
Information bit rate	kbps	384
DPCH	ksps	480
TFCI		On
Puncturing	%	22

Table A.16: DL reference measurement channel, transport channel parameters (384 kbps)

Parameter	DCCH	DTCH
Transport Channel Number	1 (TBD by WG2)	2 (TBD by WG2)

Transport Block Size	96	3840
Transport Block Set Size	96	7680
Transmission Time Interval	40 ms	20 ms
Type of Error Protection	Convolution Coding	Turbo Coding
Coding Rate	1/3	1/3
Static Rate Matching parameter	1.0	1.0
Size of CRC	16	16
Position of TrCH in radio frame	fixed	fixed

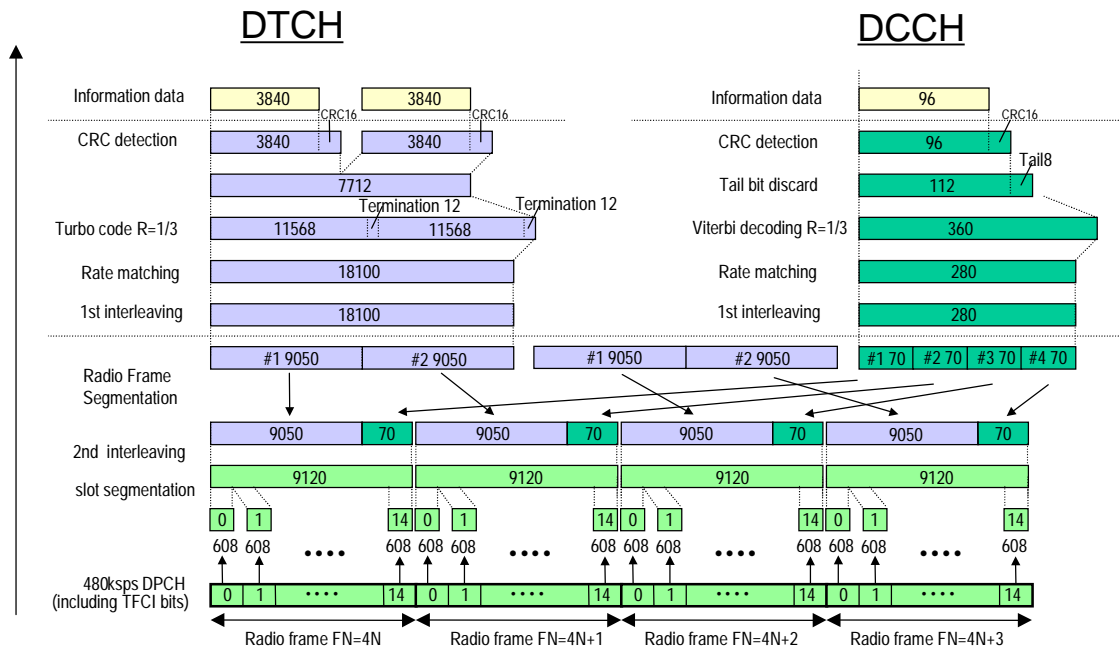

Figure A.8 (Informative): Channel coding of DL reference measurement channel (384 kbps)

A.3.5 DL reference measurement channel (384 kbps)

The parameters for the DL measurement channel for 384 kbps are specified in Table A.17 and Table A.18. The channel coding is shown for information in Figure A.9

Table A.17: DL reference measurement channel, physical parameters (384 kbps)

<u>Parameter</u>	<u>Unit</u>	<u>Level</u>
<u>Information bit rate</u>	<u>kbps</u>	<u>384</u>
<u>DPCH</u>	<u>ksps</u>	<u>480</u>
<u>TFCI</u>		<u>On</u>
<u>Puncturing</u>	<u>%</u>	<u>22</u>

Table A.18: DL reference measurement channel, transport channel parameters (384 kbps)

<u>Parameter</u>	<u>DTCH</u>	<u>DCCH</u>
<u>Transport Channel Number</u>	<u>1</u>	<u>2</u>
<u>Transport Block Size</u>	<u>3840</u>	<u>100</u>
<u>Transport Block Set Size</u>	<u>3840</u>	<u>100</u>
<u>Transmission Time Interval</u>	<u>10 ms</u>	<u>40 ms</u>
<u>Type of Error Protection</u>	<u>Turbo Coding</u>	<u>Convolution Coding</u>
<u>Coding Rate</u>	<u>1/3</u>	<u>1/3</u>
<u>Static Rate Matching parameter</u>	<u>1.0</u>	<u>1.0</u>
<u>Size of CRC</u>	<u>16</u>	<u>12</u>
<u>Position of TrCH in radio frame</u>	<u>fixed</u>	<u>Fixed</u>

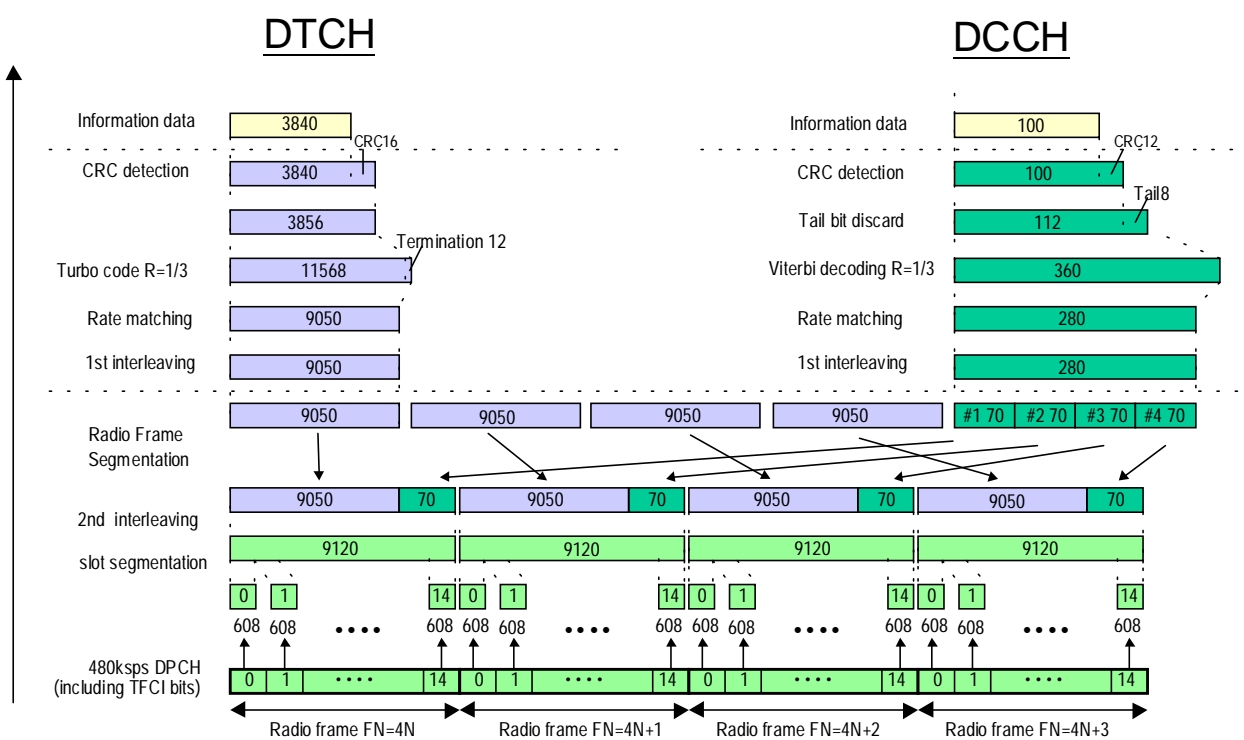
**Figure A.x (Informative): Channel coding of DL reference measurement channel (384 kbps)**

A.4 DL reference compressed mode parameters

The following parameters characterise the transmission gap :

TGL : 7

SFN : FFS

SN : FFS

The following parameters characterise the compressed mode pattern :

TGP : FFS

TGL : 7

TGD : FFS

PD: FFS

SFN : FFS

PCM: FFS

Transmission time reduction method FFS

CHANGE REQUEST

Please see embedded help file at the bottom of this page for instructions on how to fill in this form correctly.

25.101 CR 039

Current Version: **3.1.1**

GSM (AA.BB) or 3G (AA.BBB) specification number ↑

↑ CR number as allocated by MCC support team

For submission to: **TSG RAN #7**
list expected approval meeting # here ↑

for approval
for information

strategic
non-strategic (for SMG use only)

Form: CR cover sheet, version 2 for 3GPP and SMG The latest version of this form is available from: <ftp://ftp.3gpp.org/Information/CR-Form-v2.doc>

Proposed change affects: (U)SIM ME UTRAN / Radio Core Network
(at least one should be marked with an X)

Source: RAN WG4 **Date:** 2000-03-03

Subject: Modification to the handling of measurement equipment uncertainty.

Work item:

Category: <small>(only one category shall be marked with an X)</small>	F Correction	<input checked="" type="checkbox"/>	Release:	Phase 2	<input type="checkbox"/>
	A Corresponds to a correction in an earlier release	<input type="checkbox"/>		Release 96	<input type="checkbox"/>
	B Addition of feature	<input type="checkbox"/>		Release 97	<input type="checkbox"/>
	C Functional modification of feature	<input type="checkbox"/>		Release 98	<input type="checkbox"/>
	D Editorial modification	<input type="checkbox"/>		Release 99	<input checked="" type="checkbox"/>
			Release 00	<input type="checkbox"/>	

Reason for change: Due to a previous misunderstanding the specification is returned to its original position.

Clauses affected: 4

Other specs affected:	Other 3G core specifications	<input type="checkbox"/>	→ List of CRs:	
	Other GSM core specifications	<input type="checkbox"/>	→ List of CRs:	
	MS test specifications	<input type="checkbox"/>	→ List of CRs:	
	BSS test specifications	<input type="checkbox"/>	→ List of CRs:	
	O&M specifications	<input type="checkbox"/>	→ List of CRs:	

Other comments:

4 General

4.1 Measurement uncertainty

~~The requirements given in these specifications are absolute. Compliance with these requirements is determined by comparing the measured values with the specified limits, without making allowance for measurement uncertainty.~~

The requirements given in this specification make no allowance for measurement uncertainty. Where the measurement uncertainty can be determined, the test limit shall be relaxed from the value given in this specification. See Annex F of 34.121. Where the measurement uncertainty cannot reasonably be determined, the “Shared Risk” principle is applied, i.e. the test limit is not relaxed.

The Shared Risk principle is defined in ETR 028.