

TS 25.413 V2.1.0 (1999-12)

Technical Specification

**3rd Generation Partnership Project (3GPP);
Technical Specification Group (TSG) RAN
UTRAN Iu Interface RANAP Signalling**

[UMTS 25.413]

3GPP

Reference

<Workitem> (<Shortfilename>.PDF)

Keywords

<keyword[, keyword]>

3GPP

Postal address

Office address

Internet

secretariat@3gpp.org

Individual copies of this deliverable
can be downloaded from

<http://www.3gpp.org>

Copyright Notification

No part may be reproduced except as authorized by written permission.
The copyright and the foregoing restriction extend to reproduction in all media.

©

All rights reserved.

Contents

Intellectual Property Rights.....	8
Foreword.....	8
1 Scope.....	8
2 References.....	8
3 Definitions and Abbreviations.....	9
3.1 Definitions.....	9
3.2 Abbreviations.....	10
4 General.....	11
4.1 Procedure Specification Principles.....	11
4.2 Forwards and Backwards Compatibility.....	11
5 RANAP Services.....	11
6 Services Expected from Signalling Transport.....	11
7 Functions of RANAP.....	12
8 RANAP Procedures.....	13
8.1 Elementary Procedures.....	13
8.2 RAB Assignment.....	14
8.2.1 General.....	14
8.2.2 Successful Operation.....	14
8.2.3 Unsuccessful Operation.....	17
8.2.4 Abnormal Conditions.....	17
8.3 RAB Release Request.....	18
8.3.1 General.....	18
8.3.2 Successful Operation.....	18
8.3.3 Abnormal Conditions.....	19
8.4 Iu Release Request.....	19
8.4.1 General.....	19
8.4.2 Successful Operation.....	19
8.4.3 Abnormal Conditions.....	19
8.5 Iu Release.....	19
8.5.1 General.....	19
8.5.2 Successful Operation.....	20
8.5.3 Abnormal Conditions.....	20
8.6 Relocation Preparation.....	20
8.6.1 General.....	20
8.6.2 Successful Operation.....	21
8.6.3 Unsuccessful Operation.....	22
8.6.4 Abnormal Conditions.....	23
8.6.5 Co-ordination of Two Iu Signalling Connections.....	23
8.7 Relocation Resource Allocation.....	23
8.7.1 General.....	23
8.7.2 Successful Operation.....	23
8.7.3 Unsuccessful Operation.....	24
8.7.4 Abnormal Conditions.....	25
8.7.5 Co-ordination of Two Iu Signalling Connections.....	25
8.8 Relocation Detect.....	26
8.8.1 General.....	26
8.8.2 Successful Operation.....	26
8.8.3 Abnormal Conditions.....	26
8.8.4 Co-ordination of Multiple Iu Signalling Connections.....	26
8.9 Relocation Complete.....	27

8.9.1	General.....	27
8.9.2	Successful Operation.....	27
8.9.3	Abnormal Conditions.....	27
8.9.4	Co-ordination of Multiple Iu Signalling Connections.....	27
8.10	Relocation Cancel.....	27
8.10.1	General.....	27
8.10.2	Successful Operation.....	27
8.10.3	Unsuccessful Operation.....	28
8.10.4	Abnormal Conditions.....	28
8.10.5	Co-ordination of Two Iu Signalling Connections.....	28
8.11	SRNS Context Transfer.....	28
8.11.1	General.....	28
8.11.2	Successful Operation.....	28
8.11.3	Unsuccessful Operation.....	29
8.11.4	Abnormal Conditions.....	29
8.12	SRNS Data Forwarding Initiation.....	29
8.12.1	General.....	29
8.12.2	Successful Operation.....	29
8.12.3	Abnormal Conditions.....	30
8.13	SRNS Context Forwarding from Source RNC to CN.....	30
8.13.1	General.....	30
8.13.2	Successful Operation.....	30
8.13.3	Abnormal Conditions.....	31
8.14	SRNS Context Forwarding to Target RNC from CN.....	31
8.14.1	General.....	31
8.14.2	Successful Operation.....	31
8.14.3	Abnormal Conditions.....	31
8.15	Paging.....	31
8.15.1	General.....	31
8.15.2	Successful Operation.....	31
8.15.3	Abnormal Conditions.....	33
8.16	Common ID.....	33
8.16.1	General.....	33
8.16.2	Successful Operation.....	33
8.16.3	Abnormal Conditions.....	33
8.17	CN Invoke Trace.....	33
8.17.1	General.....	33
8.17.2	Successful Operation.....	33
8.17.3	Abnormal Conditions.....	34
8.18	Security Mode Control.....	34
8.18.1	General.....	34
8.18.2	Successful Operation.....	34
8.18.3	Unsuccessful Operation.....	35
8.18.4	Abnormal Conditions.....	35
8.19	Location Reporting Control.....	35
8.19.1	General.....	35
8.19.2	Successful Operation.....	35
8.19.3	Abnormal Conditions.....	36
8.20	Location Report.....	36
8.20.1	General.....	36
8.20.2	Successful Operation.....	36
8.20.3	Abnormal Conditions.....	37
8.21	Data Volume Report.....	37
8.21.1	General.....	37
8.21.2	Successful Operation.....	37
8.21.3	Unsuccessful Operation.....	37
8.21.4	Abnormal Conditions.....	38
8.22	Initial UE Message.....	38
8.22.1	General.....	38

8.22.2	Successful Operation.....	38
8.23	Direct Transfer.....	38
8.23.1	General.....	38
8.23.2	Successful Operation.....	38
8.23.2.1	CN Originated Direct Transfer.....	38
8.23.2.2	UTRAN Originated Direct Transfer.....	39
8.24	CN Information Broadcast.....	39
8.24.1	General.....	39
8.24.2	Successful Operation.....	39
8.24.3	Unsuccessful Operation.....	40
8.24.4	Abnormal Conditions.....	41
8.25	Overload Control.....	41
8.25.1	General.....	41
8.25.2	Philosophy.....	41
8.25.3	Successful Operation.....	41
8.25.3.1	Overload at the CN.....	41
8.25.3.2	Overload at the UTRAN.....	42
8.25.4	Abnormal Conditions.....	42
8.26	Reset.....	42
8.26.1	General.....	42
8.26.2	Successful Operation.....	43
8.26.2.1	Reset Procedure Initiated from the CN.....	43
8.26.2.2	Reset Procedure Initiated from the UTRAN.....	43
8.26.3	Abnormal Conditions.....	44
8.26.3.1	Abnormal Condition at the CN.....	44
8.26.3.2	Abnormal Condition at the UTRAN.....	44
8.26.3.3	Crossing of Reset Messages.....	44
8.27	Error Indication.....	44
8.27.1	General.....	44
8.27.2	Successful Operation.....	44
8.27.3	Abnormal Conditions.....	45
9	Elements for RANAP Communication.....	46
9.1	Message Contents.....	46
9.1.1	RAB ASSIGNMENT REQUEST.....	48
9.1.2	RAB ASSIGNMENT RESPONSE.....	49
9.1.3	RAB RELEASE REQUEST.....	50
9.1.4	IU RELEASE REQUEST.....	50
9.1.5	IU RELEASE COMMAND.....	51
9.1.6	IU RELEASE COMPLETE.....	51
9.1.7	RELOCATION REQUIRED.....	52
9.1.8	RELOCATION REQUEST.....	52
9.1.9	RELOCATION REQUEST ACKNOWLEDGE.....	53
9.1.10	RELOCATION COMMAND.....	54
9.1.11	RELOCATION DETECT.....	55
9.1.12	RELOCATION COMPLETE.....	55
9.1.13	RELOCATION PREPARATION FAILURE.....	56
9.1.14	RELOCATION FAILURE.....	56
9.1.15	RELOCATION CANCEL.....	56
9.1.16	RELOCATION CANCEL ACKNOWLEDGE.....	56
9.1.17	SRNS CONTEXT REQUEST.....	57
9.1.18	SRNS CONTEXT RESPONSE.....	57
9.1.19	SRNS DATA FORWARD COMMAND.....	58
9.1.20	FORWARD SRNS CONTEXT.....	58
9.1.21	PAGING.....	59
9.1.22	COMMON ID.....	59
9.1.23	CN INVOKE TRACE.....	60
9.1.24	SECURITY MODE COMMAND.....	60
9.1.25	SECURITY MODE COMPLETE.....	60

9.1.26	SECURITY MODE REJECT	61
9.1.27	LOCATION REPORTING CONTROL	61
9.1.28	LOCATION REPORT	61
9.1.29	DATA VOLUME REPORT REQUEST	62
9.1.30	DATA VOLUME REPORT	62
9.1.31	INITIAL UE MESSAGE	62
9.1.32	DIRECT TRANSFER	63
9.1.33	CN INFORMATION BROADCAST REQUEST	63
9.1.34	CN INFORMATION BROADCAST CONFIRM	64
9.1.35	CN INFORMATION BROADCAST REJECT	64
9.1.36	OVERLOAD	65
9.1.37	RESET	65
9.1.38	RESET ACKNOWLEDGE	65
9.1.39	ERROR INDICATION	65
9.2	Information Element Definitions	67
9.2.1	Radio Network Layer Related IEs	67
9.2.1.1	Message Type	67
9.2.1.2	RAB ID	67
9.2.1.3	RAB Parameters	67
9.2.1.4	Cause	69
9.2.1.5	CN Domain Indicator	72
9.2.1.6	Trace Type	72
9.2.1.7	Trigger ID	73
9.2.1.8	Trace Reference	73
9.2.1.9	UE Identity	73
9.2.1.10	OMC ID	74
9.2.1.11	Integrity Protection Information	74
9.2.1.12	Encryption Information	75
9.2.1.13	Chosen Integrity Protection Algorithm	75
9.2.1.14	Chosen Encryption Algorithm	75
9.2.1.15	Categorisation Parameters	76
9.2.1.16	Request Type	76
9.2.1.17	Data Volume Reporting Indication	76
9.2.1.18	User Plane Mode	76
9.2.1.19	UP Mode Versions	77
9.2.1.20	Chosen UP Version	77
9.2.1.21	Paging Area ID	77
9.2.1.22	Non Searching Indication	78
9.2.1.23	Relocation Type	78
9.2.1.24	Source ID	78
9.2.1.25	Target ID	79
9.2.1.26	MS Classmark 2	79
9.2.1.27	MS Classmark 3	80
9.2.1.28	Source RNC to Target RNC Transparent Container	80
9.2.1.29	Old BSS to New BSS Information	80
9.2.1.30	Target RNC to Source RNC Transparent Container	81
9.2.1.31	L3 Information	81
9.2.1.32	Number of Steps	81
9.2.1.33	DL N-PDU Sequence Number	81
9.2.1.34	UL N-PDU Sequence Number	82
9.2.1.35	Criticality Diagnostics IE	82
9.2.2	Transport Network Layer Related IEs	83
9.2.2.1	Transport Layer Address	83
9.2.2.2	Iu Transport Association	83
9.2.2.3	DL GTP-PDU Sequence Number	83
9.2.2.4	UL GTP-PDU Sequence Number	83
9.2.3	NAS Related IEs	84
9.2.3.1	NAS Binding Information	84
9.2.3.2	Permanent NAS UE Identity	84

9.2.3.3	Temporary UE ID.....	84
9.2.3.4	Paging Cause.....	85
9.2.3.5	NAS Broadcast Information.....	85
9.2.3.6	NAS PDU.....	85
9.2.3.7	LAI.....	85
9.2.3.8	RAC.....	86
9.2.3.9	SAPI.....	86
9.2.3.10	SAI.....	86
9.2.3.11	Area Identity.....	87
9.2.3.12	Geographical Area.....	87
9.2.3.13	Unsuccessfully Transmitted Data Volume.....	88
9.2.3.14	Data Volume Reference.....	88
9.2.4	RANAP Information used in non-RANAP Protocols.....	89
9.2.4.1	RANAP Relocation Information.....	89
9.3	Message and Information Element Abstract Syntax (with ASN.1).....	90
9.3.1	Usage of protocol extension mechanism for non-standard use.....	90
9.3.2	Elementary Procedure Definitions.....	90
9.3.3	PDU Definitions.....	98
9.3.4	Information Element Definitions.....	138
9.3.5	Common Definitions.....	153
9.3.6	Constant Definitions.....	154
9.3.7	Container Definitions.....	157
9.4	Message Transfer Syntax.....	163
9.5	Timers.....	163
10	Handling of Unknown, Unforeseen and Erroneous Protocol Data.....	164
10.1	General.....	164
10.2	Transfer Syntax Error.....	164
10.3	Abstract Syntax Error.....	164
10.3.1	General.....	164
10.3.2	Handling of the Criticality Information at Reception.....	164
10.3.2.1	Procedure Code.....	164
10.3.2.2	IEs other than the Procedure Code.....	165
10.4	Logical Error Handling.....	165
11	History.....	166

Intellectual Property Rights

Foreword

This Technical Specification has been produced by the 3rd Generation Partnership Project, Technical Specification Group <TSG name>.

The contents of this TS may be subject to continuing work within the 3GPP and may change following formal TSG approval. Should the TSG modify the contents of this TS, it will be re-released with an identifying change of release date and an increase in version number as follows:

Version m.t.e

where:

m indicates [major version number]

x the second digit is incremented for all changes of substance, i.e. technical enhancements, corrections, updates, etc.

y the third digit is incremented when editorial only changes have been incorporated into the specification.

Scope

This document specifies the radio network layer signalling protocol called Radio Access Network Application Part (RANAP) for the Iu interface. RANAP supports the functions of Iu interface by signalling procedures defined in this document. RANAP is developed in accordance to the general principles stated in [1], [2] and [3].

References

The following documents contain provisions which, through reference in this text, constitute provisions of the present document.

- References are either specific (identified by date of publication, edition number, version number, etc.) or non-specific.
- For a specific reference, subsequent revisions do not apply.
- For a non-specific reference, the latest version applies.
- A non-specific reference to an ETS shall also be taken to refer to later versions published as an EN with the same number.

- [1] UMTS 23.930, Iu Principles
- [2] UMTS 25.410, UTRAN Iu Interface; General Aspects and Principles
- [3] UMTS 25.401, UTRAN Overall Description
- [4] UMTS 25.931, UTRAN Functions, Examples on Signalling Procedures
- [5] UMTS 25.412, UTRAN Iu Interface Signalling Transport
- [6] UMTS 25.415, Iu Interface CN-UTRAN User Plane Protocol

- [7] UMTS 23.107, QoS Concept and Architecture
- [8] UMTS 24.008
- [9] UMTS 25.414
- [10] UMTS 25.331
- [11] GSM 08.08
- [12] GSM 12.08
- [13] X.691 (12/94) Information Technology - ASN.1 encoding rules - Specification of Packed Encoding Rules (PER)
- [14] X.680, (12/94) Information Technology - Abstract Syntax Notation One (ASN.1):Specification of basic notation
- [15] X.681, (12/94) Information Technology - Abstract Syntax Notation One (ASN.1): Information object specification

Definitions and Abbreviations

Definitions

For the purposes of the present document, the [following] terms and definitions [given in ... and the following] apply.

Relocation of SRNS: Relocation of SRNS is a UMTS functionality used to relocate the serving RNS role from one RNS to another RNS. This UMTS functionality is realised by several elementary procedures executed in several interfaces and by several protocols and it may involve a change in the radio resources used between UTRAN and UE.

It is also possible to relocate the serving RNS role from

- one RNS within UMTS to another relocation target external to UMTS
- functionality equivalent to the serving RNS role from another relocation source external to UMTS to another RNS.

Serving RNS (SRNS): A role an RNS can take with respect to a specific connection between an UE and UTRAN. There is one Serving RNS for each UE that has a connection to UTRAN. The Serving RNS is in charge of the radio connection between a UE and the UTRAN. The Serving RNS terminates the Iu for this UE.

Serving RNC (SRNC): SRNC is the RNC belonging to SRNS.

Source RNS: A role, with respect to a specific connection between UTRAN and CN, that RNS takes when it decides to initiate a relocation of SRNS.

Source RNC: Source RNC is the RNC belonging to source RNS.

Target RNS: A role an RNS gets with respect to a specific connection between UTRAN and CN when it is being a subject of a relocation of SRNS which is being made towards that RNS.

Target RNC: Target RNC is the RNC belonging to target RNS.

Elementary Procedure: The RANAP protocol consists of Elementary Procedures (EPs). An Elementary Procedure is a unit of interaction between the RNS and the CN. An EP consists of an initiating message and possibly a response message. Three kinds of EPs are used:

- **Class 1:** Elementary Procedures with response (success or failure).
- **Class 2:** Elementary Procedures without response.
- **Class 3:** Elementary Procedures with possibility of multiple responses.

For Class 1 EPs, the types of responses can be as follows:

Successful

- A signalling message explicitly indicates that the elementary procedure successfully completed with the receipt of the response.

Unsuccessful

- A signalling message explicitly indicates that the EP failed.
- On time supervision expiry (i.e. absence of expected response).

Class 2 EPs are considered always successful.

Class 3 EPs have one or several response messages reporting both successful, unsuccessful outcome of the requests and temporary status information about the requests. This type of EP only terminates through response(s) or EP timer expiry.

-

Abbreviations

AAL2	ATM Adaptation Layer type 2
AS	Access Stratum
ASN.1	Abstract Syntax Notation One
ATM	Asynchronous Transfer Mode
CN	Core Network
CRNC	Controlling RNC
CS	Circuit Switched
DRNC	Drift RNC
DRNS	Drift RNS
EP	Elementary Procedure
IMEI	International Mobile Equipment Identity
IMSI	International Mobile Subscriber Identity
MSC	Mobile services Switching Center
NAS	Non Access Stratum
P-TMSI	Packet TMSI
PDU	Protocol Data Unit
PS	Packet Switched
QoS	Quality of Service
RAB	Radio Access Bearer
RNC	Radio Network Controller
RNS	Radio Network Subsystem
RANAP	Radio Access Network Application Part
SAI	Service Area Identifier
SCCP	Signalling Connection Control Part
SGSN	Serving GPRS Support Node
SRNC	Serving RNC
SRNS	Serving RNS
TEID	Tunnel Endpoint Identifier
TMSI	Temporary Mobile Subscriber Identity
UE	User Equipment
UTRAN	UMTS Terrestrial Radio Access Network

General

Procedure Specification Principles

The principle for specifying the procedure logic is to specify the functional behaviour of the RNC exactly and completely. The CN functional behaviour is left unspecified. The EPs Relocation Preparation, Reset and Overload Control are exceptions from this principle.

Forwards and Backwards Compatibility

The forwards and backwards compatibility of the protocol is assured by mechanism where all current and future messages, and IEs or groups of related IEs, include Id and criticality fields that are coded in a standard format that will not be changed in the future. These parts can always be decoded regardless of the standard version.

RANAP Services

RANAP provides the signalling service between UTRAN and CN that is required to fulfil the RANAP functions described in section 7. RANAP services are divided into three groups based on Service Access Points (SAP) defined in UMTS TS 23.110:

1. General control services: They are related to the whole Iu interface instance between RNC and logical CN domain, and are accessed in CN through the General Control SAP. They utilise connection-less signalling transport provided by the Iu signalling bearer.
2. Notification services: They are related to specified UEs or all UEs in specified area, and are accessed in CN through the Notification SAP. They utilise connection-less signalling transport provided by the Iu signalling bearer.
3. Dedicated control services: They are related to one UE, and are accessed in CN through the Dedicated Control SAP. RANAP functions that provide these services are associated with Iu signalling connection that is maintained for the UE in question. The Iu signalling connection is realised with connection-oriented signalling transport provided by the Iu signalling bearer.

Services Expected from Signalling Transport

Signalling transport shall provide two different service modes for the RANAP.

1. Connection oriented data transfer service. This service is supported by a signalling connection between RNC and CN domain. It shall be possible to dynamically establish and release signalling connections based on the need. Each active UE shall have its own signalling connection. The signalling connection shall provide in sequence delivery of RANAP messages. RANAP shall be notified if the signalling connection breaks.
2. Connectionless data transfer service. RANAP shall be notified in case a RANAP message did not reach the intended peer RANAP entity.

Functions of RANAP

Note. This section needs to be checked after the Iu functions have been specified.

RANAP protocol has the following functions:

- Relocating serving RNC. This function enables to change the serving RNC functionality as well as the related Iu resources (RAB(s) and Signalling connection) from one RNC to another.
- Overall RAB management. This function is responsible for setting up, modifying and releasing RABs.
- Queuing the setup of RAB. The purpose of this function is to allow placing some requested RABs into a queue, and indicate the peer entity about the queuing.
- Requesting RAB release. While the overall RAB management is a function of the CN, the UTRAN has the capability to request the release of RAB.
- Release of all Iu resources. This function is used to explicitly release all resources related to one UE from the corresponding Iu connection.
- Requesting the release of all Iu resources. While the Iu release is managed from the CN, the UTRAN has the capability to request the release of all Iu resources from the corresponding Iu connection.
- SRNS context forwarding function. This function is responsible for transferring SRNS context from the RNC to the CN for intersystem forward handover in case of packet forwarding.
- Controlling overload in the Iu interface. This function allows adjusting the load in the Iu interface.
- Resetting the Iu. This function is used for resetting an Iu interface.
- Sending the UE Common ID (permanent NAS UE identity) to the RNC. This function makes the RNC aware of the UE's Common ID.
- Paging the user. This function provides the CN for capability to page the UE.
- Controlling the tracing of the UE activity. This function allows setting the trace mode for a given UE.
- Transport of NAS information between UE and CN. This function has three sub-classes.
 - Transport of the initial NAS signalling message from the UE to CN. This function transfers transparently the NAS information. As a consequence also the Iu signalling connection is set up.
 - Transport of NAS signalling messages between UE and CN, This function transfers transparently the NAS signalling messages on the existing Iu signalling connection.
 - Transport of NAS information to be broadcasted to UEs. This function allows setting the NAS information to be broadcasted to the UEs from the CN.
- Controlling the security mode in the UTRAN. This function is used to send the security keys (ciphering and integrity check) to the UTRAN, and setting the operation mode for security functions.
- Controlling location reporting. This function allows the CN to set the mode in which the UTRAN reports the location of the UE
- Location reporting. This function is used for transferring the actual location information from RNC to the CN.
- Data volume reporting function. This function is responsible for reporting unsuccessfully transmitted DL data volume over UTRAN for specific RABs.
- Reporting general error situations. This function allows reporting of general error situations, for which function specific error messages have not been defined.

These functions are implemented by one or several RANAP elementary procedures described in the following section.

RANAP Procedures

Elementary Procedures

In the following tables, all EPs are divided into Class 1, Class 2 and Class 3 EPs:

Class 1

Elementary Procedure	Initiating Message	Successful Outcome	Unsuccessful Outcome	
		Response message	Response message	
Iu Release	IU RELEASE COMMAND	IU RELEASE COMPLETE		
Relocation Preparation	RELOCATION REQUIRED	RELOCATION COMMAND	RELOCATION PREPARATION FAILURE	
Relocation Resource Allocation	RELOCATION REQUEST	RELOCATION REQUEST ACKNOWLEDGE	RELOCATION FAILURE	
Relocation Cancel	RELOCATION CANCEL	RELOCATION CANCEL ACKNOWLEDGE		
SRNS Context Transfer	SRNS CONTEXT REQUEST	SRNS CONTEXT RESPONSE		
Security Mode Control	SECURITY MODE COMMAND	SECURITY MODE COMPLETE	SECURITY MODE REJECT	
Data Volume Report	DATA VOLUME REPORT REQUEST	DATA VOLUME REPORT		
Cn Information Broadcast	CN INFORMATION BROADCAST REQUEST	CN INFORMATION BROADCAST CONFIRM	CN INFORMATION BROADCAST REJECT	
Reset	RESET	RESET ACKNOWLEDGE		

Class 2

Elementary Procedure	Message
RAB Release Request	RAB RELEASE REQUEST
Iu Release Request	IU RELEASE REQUEST

Relocation Detect	RELOCATION DETECT
Relocation Complete	RELOCATION COMPLETE
SRNS Data Forwarding Initiation	SRNS DATA FORWARD COMMAND
SRNS Context Forwarding from Source RNC to CN	FORWARD SRNS CONTEXT
SRNS Data Forwarding to Target RNC from CN	FORWARD SRNS CONTEXT
Paging	PAGING
Common ID	COMMON ID
CN Invoke Trace	CN INVOKE TRACE
Location Reporting Control	LOCATION REPORTING CONTROL
Location Report	LOCATION REPORT
Initial UE Message	INITIAL UE MESSAGE
Direct Transfer	DIRECT TRANSFER
Overload Control	OVERLOAD
Error Indication	ERROR INDICATION

Class 3

Elementary Procedure	Initiating Message	Response Message
RAB Assignment	RAB ASSIGNMENT REQUEST	RAB ASSIGNMENT RESPONSE x N (N>=1)

The following applies concerning interaction between Elementary Procedures:

- The Reset procedure can interact with all EPs.
- The Iu Release procedure can interact with all EPs except the *Reset* procedure.

RAB Assignment

General

The purpose of the RAB Assignment procedure is to enable modifications and/or releases of already established RABs and/or the establishment of new RABs for a given UE. The procedure uses connection oriented signaling.

Successful Operation

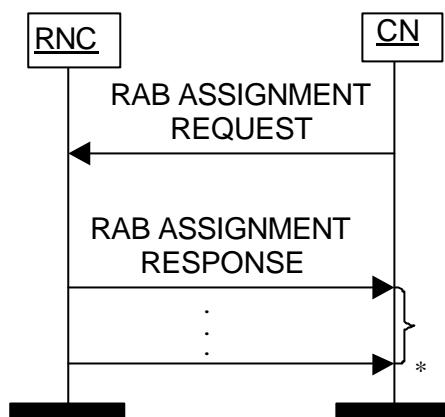

* it can be several responses

Figure 1. RAB Assignment procedure.

The CN shall initiate the procedure by sending a RAB ASSIGNMENT REQUEST message. When sending the RAB ASSIGNMENT REQUEST, the CN shall start the $T_{RABAssgt}$ timer.

The CN may request UTRAN to:

- establish
- modify
- release

one or several RABs with one RAB ASSIGNMENT REQUEST message.

The message shall contain the information required by the UTRAN to build the new RAB configuration, such as

- list of RABs to establish or modify with their bearer characteristics
- list of RABs to release

For each RAB requested to establish or modify, the message shall contain:

- RAB ID
- NAS Binding Information
- RAB parameters (including e.g. Allocation/Retention Priority)
- Data Volume Reporting Indication (only for PS)
- User Plane Mode
- Transport Layer Address
- Iu Transport Association
- DL GTP-PDU sequence number (only in case of handover from GPRS to UMTS)
- UL GTP-PDU sequence number (only in case of handover from GPRS to UMTS)
- DL N-PDU sequence number (only in case of handover from GPRS to UMTS)
- DL N-PDU sequence number (only in case of handover from GPRS to UMTS)

For each RAB request to release, the message shall contain:

- RAB ID
- Cause

For each RAB requested to establish the message shall contain:

DL GTP-PDU sequence number (in case of the RAB being established for an existing PDP context or in case of handover from GPRS to UMTS)

UL GTP-PDU sequence number (in case of the RAB being established for an existing PDP context or in case of handover from GPRS to UMTS)

Upon reception of the RAB ASSIGNMENT REQUEST message UTRAN shall execute the requested RAB configuration.

The RAB ID shall identify uniquely the RAB over the Iu instance on which the RAB ASSIGNMENT REQUEST message is received. If conflict arises with already established RABs (e.g. same RAB ID already in use over that particular Iu instance), the RNC shall respond to the RAB ASSIGNMENT REQUEST message with the unsuccessful outcome for that particular requested RAB.

The RNC shall pass the *NAS Binding Information* IE transparently to the radio interface protocol for each RAB requested to establish or modify.

The RNC shall establish the resources according to the values of the *Allocation/Retention Priority* IE (priority level, pre-emption indication, queuing) and the resource situation as follows:

The RNC shall consider the priority level of the requested RAB, when deciding on the resource allocation.

If the requested RAB is allowed for queuing and the resource situation requires, RNC may place the RAB in the establishment queue.

The priority levels and the pre-emption indicators may (singularly or in combination) be used to determine whether the RAB assignment has to be performed unconditionally and immediately. If the requested RAB is allowed to pre-empt and the resource situation requires, RNC may trigger the pre-emption procedure which may then cause the forced release of a lower priority RAB vulnerable for pre-emption, if no free resource is immediately available. Whilst the process and the extent of the pre-emption procedure is operator dependent, the pre-emption indicators, if given in the RAB ASSIGNMENT REQUEST, shall be treated as follows:

- the last received "Pre-emption Vulnerability indicator" and priority levels shall prevail.
- if the "Pre-emption Capability indicator" is set, then this allocation request may trigger the running of the pre-emption procedure.
- if the "Pre-emption Capability indicator" is not set, then this allocation request may not trigger the pre-emption procedure.
- if the "Pre-emption Vulnerability indicator" is set, then this connection is vulnerable and shall be included in the pre-emption process.
- if the "Pre-emption Vulnerability" bit is not set, then this connection is not vulnerable to pre-emption and shall not be included in the pre-emption process.
- if no priority has been indicated, both "Pre-emption Capability" and "Pre-emption Vulnerability" indicators shall not be considered.

The UTRAN pre-emption process shall keep the following rules:

- UTRAN shall only pre-empt RABs with lower priority, in ascending order of priority.
- The pre-emption can be done for RABs belonging to the same UE or to other UEs.

UTRAN shall report to CN the outcome of the request by sending RAB ASSIGNMENT RESPONSE message(s).

UTRAN shall report to CN, in one RAB ASSIGNMENT RESPONSE message, the result for all the requested RABs, such as:

- List of RABs successfully established
- List of RABs successfully modified RABs
- List of RABs released
- List of RABs failed to establish or modify or release
- List of RABs queued

If none of the RABs have been queued, the CN shall stop timer $T_{RABAssgt}$. And the *RAB Assignment* procedure terminates. In that case, the procedure shall also be terminated in UTRAN.

When the request to establish or modify one or several RABs is put in the queue, UTRAN shall start the timer $T_{QUEUING}$. This timer specifies the maximum time for queuing of the request of establishment or modification. The same timer $T_{QUEUING}$ is supervising all RABs being queued.

For each RABs that are queued the following outcomes shall be possible:

- successfully established or modified
- failed to establish or modify
- failed due to expiry of the timer $T_{QUEUING}$

For the queued RABs, indicated in the first RAB ASSIGNMENT RESPONSE message, UTRAN shall report the outcome of the queuing in the case of $T_{QUEUING}$ expiry, for every RAB individually or for several RABs in subsequent RAB ASSIGNMENT RESPONSE message(s). This is left to implementation. UTRAN shall stop $T_{QUEUING}$ when all RABs have been either successfully established or modified or failed to establish or modify. The *RAB Assignment* procedure is then terminated both in CN and UTRAN.

When CN receives the response that one or several RABs are queued, CN shall expect UTRAN to provide the outcome of the queuing function for each RAB before expiry of the $T_{RABAssgt}$ timer. In case the timer $T_{RABAssgt}$ expires, the CN shall consider the *RAB Assignment* procedure terminated and the not reported RABs shall be considered as failed.

In the case the timer $T_{QUEUING}$ expires, the *RAB Assignment* procedure terminates in UTRAN for all queued RABs, and UTRAN shall respond for all of them in one RAB ASSIGNMENT RESPONSE message. The *RAB Assignment* procedure shall also be terminated in CN.

UTRAN shall report the outcome of a specific RAB to establish or modify only after the transport network control plane signalling, which is needed for RAB establishment or modification, has been executed. The transport network control plane signalling shall use the *Transport Layer Address IE* and *Iu Transport Association IE*.

After reporting the outcome of a specific RAB to establish or modify, the RNC shall initiate the user plane mode as requested by the CN in the *User Plane Mode IE*. This initialisation is described in ref.[6].

When UTRAN reports unsuccessful modification of RAB configuration the cause value should be precise enough to enable the core network to know the reason for unsuccessful modification. Typical cause values are: "Requested Traffic Class not Available", "Invalid RAB Parameters Value", "Requested Maximum Bit Rate not Available", "Requested Guaranteed Bit Rate not Available", "Requested Transfer Delay not Achievable", "Invalid RAB Parameters Combination", "Condition Violation for SDU Parameters", "Condition Violation for Traffic Handling Priority", "Condition Violation for Guaranteed Bit Rate", "User Plane Versions not Supported", "Iu UP Failure".

Unsuccessful Operation

The unsuccessful operation for this Class 3 Elementary procedure is described under the Successful Operation chapter.

Abnormal Conditions

Interactions with Relocation Preparation:

If the relocation becomes absolutely necessary during the RAB Assignment in order to keep the communication with the UE, the RNC may interrupt the the ongoing RAB Assignment procedure and initiate the Relocation Preparation procedure as follows:

1. The RNC shall terminate the RAB Assignment procedure indicating unsuccessful RAB configuration modification:
 - for all queued RABs,
 - for RABs not already established or modified and
 - for RABs not already released
 with the cause 'Relocation triggered'.
2. The RNC shall terminate the RAB Assignment procedure indicating successful RAB configuration modification:
 - for RABs already established or modified but not yet reported to the CN and
 - for RABs already released but not yet reported to the CN.
3. The RNC shall report this outcome of the procedure in one RAB ASSIGNMENT RESPONSE message.
4. The RNC shall invoke relocation by sending the RELOCATION REQUIRED to the active CN node(s).
5. The CN shall terminate the RAB Assignment procedure at reception of the RAB ASSIGNMENT RESPONSE message.

RAB Release Request

General

The purpose of the RAB Release Request procedure is to enable UTRAN to request the release of one or several radio access bearers. The procedure uses connection oriented signalling.

Successful Operation

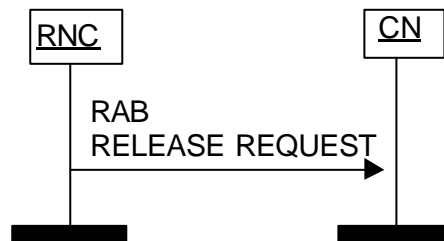

Figure 2. RAB Release Request procedure. Successful Operation.

The RNC shall initiate the procedure by generating a RAB RELEASE REQUEST message towards the CN. The *RABs to be released* IE shall indicate the list of RABs requested to release and the *Cause* IE associated to each RAB shall indicate the reason for the release.

Upon reception of the RAB RELEASE REQUEST message, the CN shall initiate the appropriate release procedure for the identified RABs in the RAB RELEASE REQUEST message. The CN shall pass the cause value indicated in the RAB RELEASE REQUEST message unchanged (TBD) in the initiated release procedure.

Abnormal Conditions

Iu Release Request

General

The purpose of the Iu Release Request procedure is to enable UTRAN to request the CN to release the Iu connection for a particular UE due to some UTRAN generated reason (e.g. "O&M Intervention", "Unspecified Failure", "RAB pre-empted", "User Inactivity"). The procedure uses connection oriented signalling.

Successful Operation



Figure 3. Iu Release Request procedure. Successful Operation.

The RNS controlling the Iu connection(s) of that particular UE shall initiate the procedure by generating an IU RELEASE REQUEST message towards the CN. If two Iu connections exist for that particular UE, RNC shall send an IU RELEASE REQUEST message to both CN domains. The procedure may be initiated for instance when the contact with a particular UE is lost or due to user inactivity.

The IU RELEASE REQUEST message shall indicate the cause value for the requested Iu connection release.

Interactions with Iu Release:

The CN shall analyse the cause for sending the IU RELEASE REQUEST message, and if accepted, the CN shall initiate the Iu Release procedure. The CN shall pass the cause value indicated in the IU RELEASE REQUEST message unchanged (TBD) in the initiated Iu Release procedure.

Abnormal Conditions

Iu Release

General

The purpose of the Iu Release procedure is to enable the CN to release the Iu connection and all UTRAN resources related only to that Iu connection to be released. The procedure uses connection oriented mode signalling.

The Iu Release procedure can be initiated for at least the following reasons:

- Completion of transaction between UE and CN.
- UTRAN generated reasons, i.e. reception of IU RELEASE REQUEST.

- Completion of successful relocation of SRNS.
- Cancellation of relocation after successful Relocation Resource Allocation procedure has already been performed.

Successful Operation

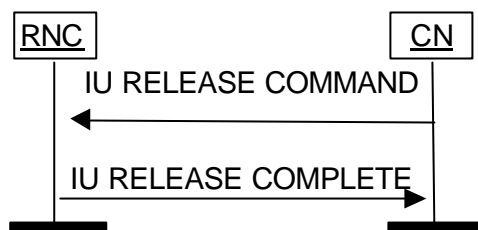

Figure 4. Iu Release procedure.

The Procedure is initiated by the CN by sending an IU RELEASE COMMAND message to the UTRAN.

After the IU RELEASE COMMAND has been sent, the CN shall not send further RANAP connection oriented messages on this particular connection.

The IU RELEASE COMMAND message shall include a *Cause* IE, indicating the reason for the release (e.g. "Successful Relocation", "Normal Release", "Release due to UTRAN Generated Reason", "Relocation Cancelled").

When the RNS receives the IU RELEASE COMMAND:

- 1) Clearing of the UTRAN resources is initiated. However, the UTRAN shall not clear resources related to other Iu signalling connections the UE might have. The Iu transport bearers for RABs subject to data forwarding and other UTRAN resources used for the GTP-PDU forwarding process, are released by the RNC only when the timer $T_{DATAfwd}$ expires.
- 2) The RNC returns any assigned Iu user plane resources to idle. Then the RNC sends an IU RELEASE COMPLETE message to the CN. (The RNC does not need to wait for the release of UTRAN radio resources to be completed before returning the IU RELEASE COMPLETE message.) When an IU RELEASE COMPLETE message is sent, the procedure is terminated in the UTRAN.

Reception of an IU RELEASE COMPLETE message terminates the procedure in the CN.

Abnormal Conditions

If the Iu Release procedure is not initiated towards the source RNC from the CN before the expiry of timer $T_{RELOCoverall}$, the source RNC should initiate the Iu Release Request procedure towards the CN with a cause value " $T_{relocoverall}$ expiry".

Relocation Preparation

General

The Purpose of the Relocation Preparation procedure is to prepare relocation of SRNS either with involving UE or without involving UE. Procedure shall be co-ordinated in all Iu signalling connections existing for the UE in order to allow Relocation Co-ordination in the target RNC. The procedure uses connection oriented signalling.

Successful Operation

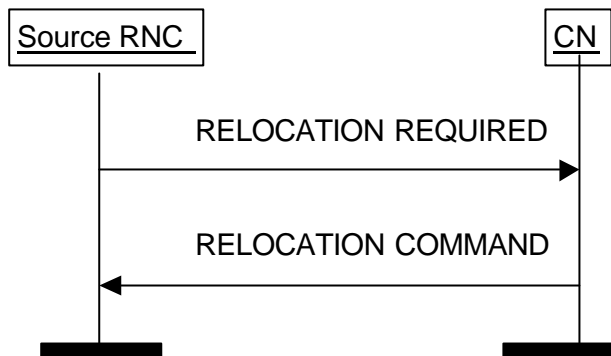

Figure 5. Relocation Preparation procedure. Successful operation.

The source RNC shall initiate the procedure by generating RELOCATION REQUIRED message. The source RNC shall decide whether to initiate the intra-system Relocation or the inter-system Relocation. In case of intra-system Relocation the source RNC shall indicate in the *Source ID* IE the RNC-ID of the source RNC and in the *Target ID* IE the RNC-ID of the target RNC. In case of inter-system Relocation the source RNC shall indicate in the *Source ID* IE the Service Area Identifier and in the *Target ID* IE the cell global identity of the target system. The source RNC shall indicate the appropriate cause value for the Relocation in the *Cause* IE.

The source RNC shall determine whether the relocation of SRNS shall be executed with or without involvement of UE. The source RNC shall set the *Relocation Type* IE accordingly to 'UE involved' or 'UE not involved'.

The source RNC shall indicate in the RELOCATION REQUIRED message the amount of Iu signalling connections existing for the UE by setting correctly the *Number of Iu Instances* IE included in the *Source to Target RNC Transparent Container* IE. This container may also include the necessary information for Relocation co-ordination, security procedures and the handling of UE Capabilities. The container may include the RRC context to be relocated within the *RRC Container* IE.

The source RNC shall send the RELOCATION REQUIRED message to CN and the source RNC shall start the timer $T_{RELOCprep}$.

When the preparation including resource allocation in the target system is ready and CN has decided to continue the relocation of SRNS, CN shall send RELOCATION COMMAND message to the source RNC and the CN shall start the timer $T_{RELOCcompl}$.

For each RAB originating from the PS domain, the RELOCATION COMMAND message may contain Iu transport address and Iu transport association to be used for the forwarding of the DL N-PDU duplicates towards the relocation target.

The Relocation Preparation procedure is terminated in CN by transmission of RELOCATION COMMAND message.

If *Relocation Type* IE was set to 'UE involved' by the source RNC and if the target system does not support all existing RABs, the RELOCATION COMMAND message shall contain a list of RABs indicating all the RABs that are not supported by the target system. The source RNC shall pass this information to radio protocols.

Upon reception of RELOCATION COMMAND belonging to ongoing Relocation Preparation procedure the source RNC shall stop the timer $T_{RELOCprep}$, RNC shall start the timer $T_{RELOCoverall}$ and RNC shall terminate the procedure.

When Relocation Preparation procedure is terminated successfully and when the source RNC is ready, the source RNC should trigger the execution of relocation of SRNS.

In case of intersystem handover to GSM the RNC shall include *MS Classmark 2* and *MS Classmark 3* IEs received from the UE in the RELOCATION REQUIRED message to CN.

Interactions with other procedures:

If, after RELOCATION REQUIRED message is sent and before the Relocation Preparation procedure is terminated, the source RNC receives a RANAP message initiating an other connection oriented RANAP class 1 or class 3 procedure (except Iu RELEASE COMMAND, which shall be handled normally) via the same Iu signalling connection, the source RNC shall either:

- cancel the Relocation Preparation procedure i.e. execute Relocation Cancel procedure and after successful completion of Relocation Cancel procedure the source RNC shall continue the initiated RANAP procedure

or

- terminate the initiated RANAP procedure without any changes in UTRAN by sending appropriate response message to CN. The source RNC shall then continue the relocation of SRNS.

If, after RELOCATION REQUIRED message is sent and before the Relocation Preparation procedure is terminated, the source RNC receives a connection oriented class 2 RANAP message via the same Iu signalling connection (except DIRECT TRANSFER message, which shall be handled normally) and if the source RNC does not decide to cancel the relocation of SRNS by initiating Relocation Cancel procedure, the source RNC shall ignore the received RANAP class 2 message.

After Relocation Preparation procedure is terminated successfully all RANAP messages (except Iu RELEASE COMMAND message, which shall be handled normally) received via the same Iu signalling bearer shall be ignored by the source RNC.

Unsuccessful Operation

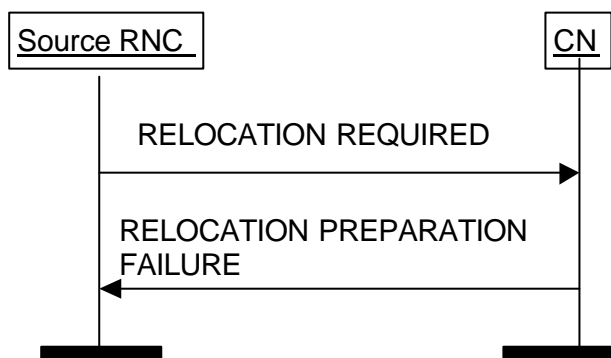

Figure 6. Relocation Preparation procedure. Unsuccessful operation.

If CN or target system is not able to even partially accept the relocation of SRNS or a failure occurs during the Relocation Preparation procedure in the CN or CN decides not to continue the relocation of SRNS, CN shall send RELOCATION PREPARATION FAILURE message to the source RNC.

RELOCATION PREPARATION FAILURE shall contain appropriate value for the *Cause IE*.

Transmission of RELOCATION PREPARATION FAILURE terminates the procedure in CN. Reception of RELOCATION PREPARATION FAILURE terminates the procedure in UTRAN.

When Relocation preparation is unsuccessfully terminated the existing Iu signalling connection can be used normally.

If the Relocation Preparation procedure is terminated unsuccessfully, CN shall release the possibly existing Iu signalling connection for the same UE and related to the same relocation of SRNS towards the target RNC by initiating Iu Release procedure towards target RNC with an appropriate value for the *Cause IE*, e.g. 'Relocation Cancelled'.

Interactions with Relocation Cancel procedure:

If there is no response from the CN to the RELOCATION REQUIRED message before timer $T_{\text{RELOCprep}}$ expires in the source RNC, the source RNC shall cancel the Relocation Preparation procedure by initiating the Relocation Cancel procedure with appropriate value for the *Cause IE*, e.g. ' $T_{\text{RELOCprep}}$ expiry'.

Abnormal Conditions

If the target RNC, which was indicated in the RELOCATION REQUIRED message, is not known to the CN:

1. The CN shall reject the relocation of SRNS by sending a RELOCATION PREPARATION FAILURE message to the source RNC with *Cause* IE set to 'Unknown target RNC'.
2. The CN shall continue to use the existing Iu connection towards the source RNC.

Co-ordination of Two Iu Signalling Connections

If Relocation Preparation procedure is to be initiated by RNC, RNC shall initiate simultaneously Relocation Preparation procedure on all Iu signalling connections existing for the UE.

The source RNC shall not trigger the execution of relocation of SRNS unless it has received RELOCATION COMMAND message from all Iu signalling connections existing for the UE.

If the source RNC receives RELOCATION PREPARATION FAILURE message from CN, RNC shall initiate Relocation Cancel procedure on the other Iu signalling connection for the UE if the other Iu signalling connection exists and if the Relocation Preparation procedure is still ongoing or the procedure has terminated successfully in that Iu signalling connection.

Relocation Resource Allocation

General

The purpose of the Relocation Resource Allocation procedure is to allocate resources from target RNS for a relocation of SRNS. Procedure shall be co-ordinated in all Iu signalling connections existing for the UE. The procedure uses connection oriented signalling.

Successful Operation

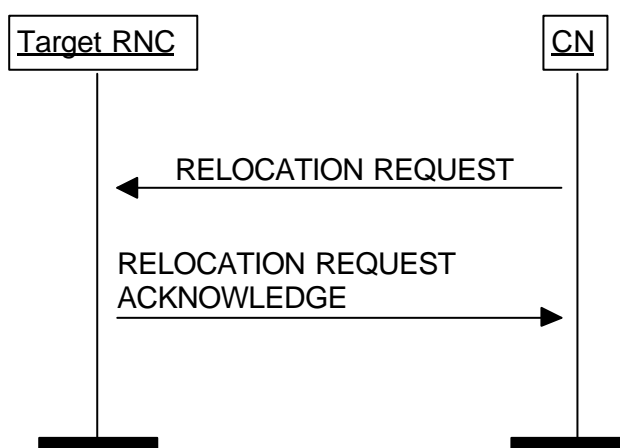

Figure 7. Relocation Resource Allocation procedure. Successful operation.

The CN shall initiate the procedure by generating RELOCATION REQUEST message. This message shall contain the information (if any) required by the UTRAN to build the new RAB configuration

CN shall transmit the RELOCATION REQUEST message to target RNC and CN shall start the timer $T_{RELOCalloc}$.

Upon reception of the RELOCATION REQUEST message target RNC shall initiate allocation of requested resources. The following information elements received in RELOCATION REQUEST message:

- *RAB-ID*
- *User plane mode*
- *Priority level, queuing and pre-emption indication*

require special actions in RNC. The actions are the same as specified for the same IEs in the RAB Assignment procedure.

Following additional actions shall be executed in target RNC during Relocation Resource Allocation procedure:

If *Relocation Type* IE is set to 'Hard Handover':

Target RNC may accept a requested RAB only if:

- the RAB can be supported by target RNC and
- the radio bearer for the RAB exists or target RNC will establish necessary radio resources for the RAB by Uu interface information to be generated by target RNC and to be included in RELOCATION REQUEST ACKNOWLEDGE message

Other RABs shall be rejected by the target RNC in the RELOCATION REQUEST ACKNOWLEDGE message with an appropriate value for *Cause* IE, e.g. 'Unable to Establish During Relocation'.

If an existing radio bearer is not related to any RAB that is accepted by target RNC, the corresponding radio bearer shall be ignored by target RNC. No actions to release the radio bearer shall be taken by target RNC.

If *RelocationType* IE is set to 'SRNS Relocation':

Target RNC may accept a RAB only if the radio bearer for the RAB exists and can be used for the RAB by the target RNC.

If an existing radio bearer is not related to any RAB that is accepted by target RNC, the corresponding radio bearer shall be ignored during the relocation of SRNS and the radio bearer shall be released by Uu interface protocols after completion of relocation of SRNS.

After all necessary resources for accepted RABs including the Iu user plane, are successfully allocated, target RNC shall send RELOCATION REQUEST ACKNOWLEDGE message to CN.

The RELOCATION REQUEST ACKNOWLEDGE message sent by the target RNC may optionally contain a transparent container, which shall be transferred by CN to the source RNC using the RANAP message RELOCATION COMMAND.

Transmission and reception of RELOCATION REQUEST ACKNOWLEDGE message terminates the procedure in UTRAN and CN respectively.

Unsuccessful Operation

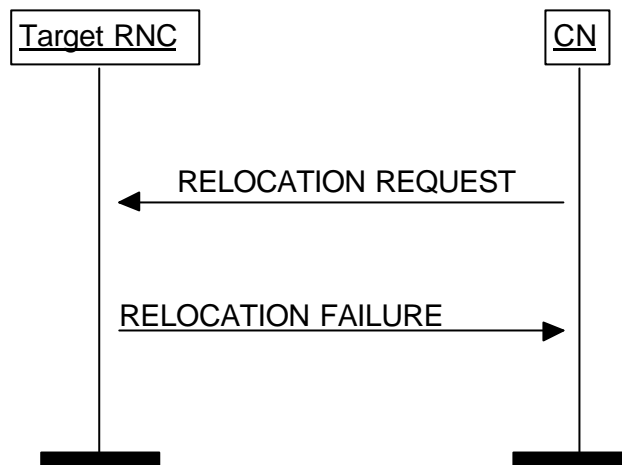

Figure 8. Relocation Resource Allocation procedure: Unsuccessful operation.

If target RNC can not even partially accept the relocation of SRNS or a failure occurs during the Relocation Resource Allocation procedure in the target RNC, the target RNC shall send RELOCATION FAILURE message to CN.

Transmission and reception of RELOCATION FAILURE message terminates the procedure in UTRAN and CN respectively.

Interactions with Iu Release:

1. When CN has received RELOCATION FAILURE message from target RNC, CN shall stop timer $T_{\text{RELOCalloc}}$ and CN shall initiate Iu Release procedure towards target RNC with an appropriate value for the *Cause* IE, e.g. 'Relocation Cancelled'.

Abnormal Conditions

If after reception of the RELOCATION REQUEST message, the target RNC receives another RELOCATION REQUEST message on the same Iu connection, then target RNC shall discard the latter message and the original Relocation Resource Allocation procedure shall continue normally.

Interactions with Iu Release:

If CN decides to not continue the Relocation Resource Allocation procedure before the Relocation Resource Allocation procedure is completed, the CN shall stop timer $T_{\text{RELOCalloc}}$ and CN shall initiate Iu Release procedure towards target RNC with an appropriate value for the *Cause* IE, e.g. 'Relocation Cancelled'.

Co-ordination of Two Iu Signalling Connections

Co-ordination of two Iu signalling connections during Relocation Resource Allocation procedure shall be executed by target RNC when the *Number of Iu Instances* IE received in RELOCATION REQUEST message indicates that two CN domains are involved in relocation of SRNS.

If two CN domains are involved, following actions shall be taken by target RNC. Target RNC shall utilise the *Permanent NAS UE Identity* IE, received explicitly by each CN domain within RELOCATION REQUEST message, to link both Iu signalling connections together.

Target RNC shall generate and send RELOCATION REQUEST ACKNOWLEDGE only after all expected RELOCATION REQUEST messages are received and analysed.

Target RNC shall ensure that there is no conflicting information in *Target RNC to Source RNC Transparent Container* IE in RELOCATION REQUEST ACKNOWLEDGE messages transmitted via different Iu signalling connections and related to the same relocation of SRNS.

The selection of signalling connection utilised for the *Target RNC to Source RNC Transparent Container IE* in RELOCATION REQUEST ACKNOWLEDGE message need not to be dependent on the signalling connection via which the *Source RNC to Target RNC Transparent Container IE* in RELOCATION REQUEST message was received.

Relocation Detect

General

The purpose of Relocation Detect procedure is to indicate by the RNC the detection of SRNS relocation execution to the CN. Procedure shall be co-ordinated in all Iu signalling connections existing for the UE. The procedure uses connection oriented signalling.

Successful Operation

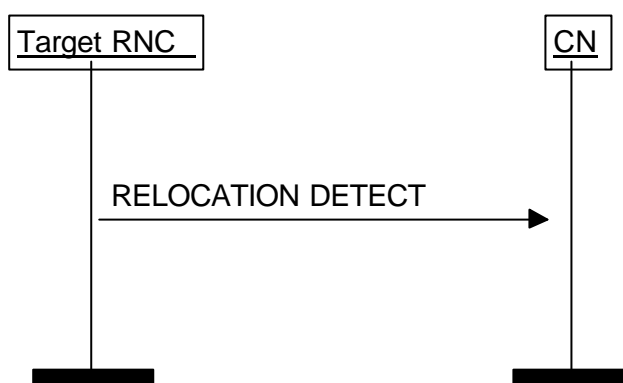

Figure 9. Relocation Detect procedure: Successful operation.

Target RNC shall send RELOCATION DETECT message to CN when relocation execution trigger is received.

If the type of relocation of SRNS is 'Hard Handover', the relocation execution trigger is received from the Uu interface. If the type of relocation of SRNS is 'SRNS Relocation', the relocation execution trigger is the reception of RELOCATION COMMIT message from Iur interface.

When RELOCATION DETECT message is sent, target RNC shall start SRNC operation.

Upon reception of RELOCATION DETECT message, CN may switch the user plane from source RNC to target RNC.

Abnormal Conditions

Interactions with Relocation Complete

If the RELOCATION COMPLETE message is received by CN before the reception of RELOCATION DETECT message CN, shall handle the RELOCATION COMPLETE message normally.

Co-ordination of Multiple Iu Signalling Connections

When Relocation Detect procedure is to be initiated by target RNC, target RNC shall initiate the Relocation Detect procedure on all Iu signalling connections existing for the UE between target RNC and CN.

Relocation Complete

General

The purpose of Relocation Complete procedure is to indicate by the Target RNC the completion of relocation of SRNS to the CN. Procedure shall be co-ordinated in all Iu signalling connections existing for the UE. The procedure uses connection oriented signalling.

Successful Operation



Figure 10. Relocation Complete procedure. Successful Operation.

When the new *SRNC-ID* + *S-RNTI* are successfully exchanged with the UE by the radio protocols, target RNC shall initiate Relocation Complete procedure by sending RELOCATION COMPLETE message to CN.

Abnormal Conditions

If the timer $T_{\text{RELOCcomplete}}$ expires:

- The CN should initiate release of Iu connections towards the source and the target RNC by initiating the Iu Release procedure with an appropriate value for the *Cause* IE, e.g. ' $T_{\text{RELOCcomplete}}$ expiry'.

Interactions with the Relocation Detect procedure:

1. If the RELOCATION DETECT message is not received by CN before reception of RELOCATION COMPLETE message, CN shall handle the RELOCATION COMPLETE message normally.

Co-ordination of Multiple Iu Signalling Connections

When Relocation Complete procedure is to be initiated by target RNC, target RNC shall initiate the Relocation Complete procedure on all Iu signalling connections existing for the UE between target RNC and CN.

Relocation Cancel

General

The purpose of the Relocation Cancel procedure is to enable source RNC to cancel an already initiated relocation of SRNS. Procedure shall be co-ordinated in all Iu signalling connections existing for the UE. The procedure uses connection oriented signalling.

Successful Operation

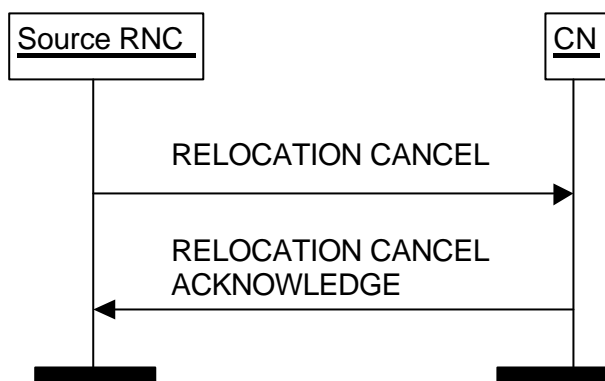

Figure 11. Relocation Cancel procedure. Successful Operation.

RNC shall initiate the procedure by sending RELOCATION CANCEL message to CN. This message shall indicate the reason for canceling the relocation of SRNS by appropriate value of the *Cause* IE. Upon reception of RELOCATION CANCEL message, CN shall send RELOCATION CANCEL ACKNOWLEDGE message to source RNC.

Transmission and reception of RELOCATION CANCEL ACKNOWLEDGE terminates the procedure in CN and source RNC respectively.

Interactions with Relocation Preparation:

Upon reception of RELOCATION CANCEL message from source RNC, CN shall locally terminate the possibly ongoing Relocation Preparation procedure towards that RNC and abandon the relocation of SRNS.

If source RNC receives RELOCATION COMMAND message from CN after Relocation Cancel procedure is initiated, source RNC shall ignore the received RELOCATION COMMAND message.

Unsuccessful Operation

Abnormal Conditions

Co-ordination of Two Iu Signalling Connections

If Relocation Cancel procedure is to be initiated due to other reasons than reception of RELOCATION PREPARATION FAILURE message, Relocation Cancel procedure shall be initiated on all Iu signalling connections existing for the UE in which the Relocation Preparation procedure has not terminated unsuccessfully.

SRNS Context Transfer

General

The purpose of the SRNS Context Transfer procedure is to trigger the transfer of SRNS contexts from the source RNC to the CN (PS domain) in case of inter system forward handover. The procedure uses connection oriented signalling.

Successful Operation

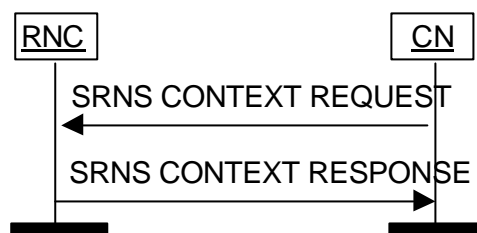

Figure 12. SRNS Context Transfer procedure.

The CN shall initiate the procedure by sending a SRNS CONTEXT REQUEST message to the source RNC. The SRNS CONTEXT REQUEST message shall include the list of RABs whose contexts should be transferred.

The source RNC shall respond to the CN with a SRNS CONTEXT RESPONSE message containing the RAB Context information for the referenced RABs. For each RAB, the following information elements shall be included:

- *RAB ID*
- the sequence number for the next downlink GTP-PDU to be sent to the UE i.e. *DL GTP-PDU Sequence Number*
- the sequence number for the next uplink GTP-PDU to be tunnelled to the GGSN i.e. *UL GTP-PDU Sequence Number*
- the sequence number of the UL Receive PDCCP-PDU which carried the last segment of the last GTP-PDU forwarded to SGSN in *DL N-PDU Sequence Number IE*
- the sequence number of the DL Send PDCCP-PDU which carried the last segment of the last N-PDU sent to the UE in *UL N-PDU Sequence Number IE*

Transmission and reception of the SRNS CONTEXT RESPONSE message shall terminate the procedure in the UTRAN and the CN respectively.

Unsuccessful Operation

Abnormal Conditions

SRNS Data Forwarding Initiation

General

The purpose of the SRNS Data Forwarding procedure is to trigger the transfer of N-PDUs from the RNC to the CN (PS domain) in case of inter system forward handover. The procedure uses connection oriented signalling.

Successful Operation

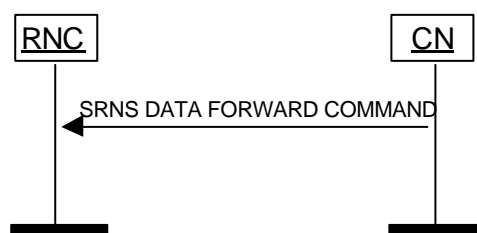

Figure 13. SRNS Data Forwarding Initiation procedure.

CN initiates the procedure by sending SRNS DATA FORWARD COMMAND message to UTRAN. SRNS DATA FORWARD COMMAND message includes the list of RABs whose data should be forwarded and the necessary information for establishing a GTP tunnel to be used for data forwarding.

Upon reception of SRNS DATA FORWARD COMMAND RNC starts the timer T(Data forwarding).

Abnormal Conditions

SRNS Context Forwarding from Source RNC to CN

General

The purpose of this procedure is to transfer SRNS contexts from the source RNC to the CN (PS domain) in case of handover via the CN. The procedure uses connection oriented signalling. SRNS contexts are sent for each concerned RAB and contain the sequence numbers of the GTP-PDUs next to be transmitted in the uplink and downlink directions and the next PDCP sequence numbers that would have been used to send and receive data from the UE.

Successful Operation

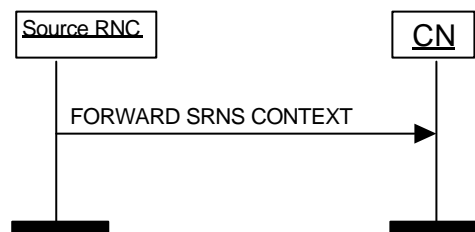

Figure 14. SRNS Context forwarding from source RNC to CN.

The source RNC initialises the procedure by sending FORWARD SRNS CONTEXT message to the CN. The FORWARD SRNS CONTEXT message contains the RAB Context information for each referenced RAB. For each RAB the following information is included

- the sequence number for the next downlink GTP-PDU to be sent to the UE, and
- the sequence number for the next uplink GTP-PDU to be tunnelled to the GGSN.
- the sequence number of the UL Receive PDCP-PDU which carried the last segment of the last GTP-PDU forwarded to SGSN in *UL N-PDU Sequence Number IE*.
- the sequence number of the DL Send PDCP-PDU which carried the last segment of the last GTP-PDU sent to the UE in *DL N-PDU Sequence Number IE*.

Abnormal Conditions

SRNS Context Forwarding to Target RNC from CN

General

The purpose of this procedure is to transfer SRNS contexts from the CN (PS domain) to the target RNC in case of handover via the CN. The procedure uses connection oriented signalling. SRNS contexts are sent for each referenced RAB and contain the sequence numbers of the GTP-PDUs next to be transmitted in the uplink and downlink directions and the next PDCP sequence numbers that would have been used to send and receive data from the UE.

Successful Operation

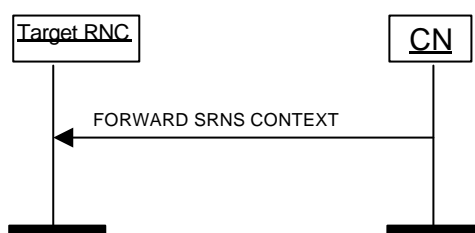

Figure 15. SRNS Context forwarding to target RNC from CN.

The CN initialises the procedure by sending FORWARD SRNS CONTEXT message to the target RNC. The FORWARD SRNS CONTEXT message contains the RAB Context information for each referenced RAB. For each RAB the following information is included

- the sequence number for the next downlink GTP-PDU to be sent to the UE, and
- the sequence number for the next uplink GTP-PDU to be tunnelled to the GGSN.
- the sequence number of the UL Receive PDCP-PDU which carried the last segment of the last GTP-PDU forwarded to SGSN in *UL N-PDU Sequence Number IE*.
- the sequence number of the DL Send PDCP-PDU which carried the last segment of the last GTP-PDU sent to the UE in *DL N-PDU Sequence Number IE*.

Abnormal Conditions

Paging

General

The purpose of the Paging procedure is to enable the CN to page a UE for a UE terminating service request. The procedure uses connectionless signalling.

Successful Operation



Figure 16. Paging procedure. Successful Operation.

The CN shall initiate the procedure by sending a PAGING message. This message shall contain information necessary for RNC to be able to page the UE, like:

- CN Domain Indicator
- Permanent NAS UE Identity
- Temporary UE Identity
- Paging Area
- Paging Cause
- Non Searching Indicator

The *CN Domain Indicator* IE shall be used by the RNC to identify from which CN domain the PAGING message originates.

The *Permanent NAS UE Identity* IE (e.g. IMSI) shall be used by the UTRAN paging co-ordination function to check if a signalling connection towards another CN already exists for this UE. In that case, the radio interface paging message can be sent via that connection instead of using the paging broadcast channel.

The *Temporary UE Identity* IE (e.g. TMSI) is the identity of the user that shall be used over the paging channel. If the *Temporary UE Identity* IE is not included in the PAGING message, the RNC shall use the Permanent UE Identity instead.

The *Paging Area* IE shall be used by the RNC to identify the area in which the radio interface paging message shall be broadcast in case no signalling connection, as described above, already exists for the UE. If the *Paging Area* IE is not included in the PAGING message, the whole RNC area shall be used as Paging Area.

The *Paging Cause* IE shall indicate to the RNC the reason for sending the PAGING message.

The *Non Searching Indication* IE shall be used by the RNC to decide whether the UTRAN paging co-ordination function needs to be activated or not.

It should be noted that each PAGING message on the Iu interface relates to only one UE and therefore the RNC has to pack the pages into the relevant radio interface paging message.

The core network is responsible for the paging repetition over the Iu interface.

Abnormal Conditions

Common ID

General

The purpose of the Common ID procedure is to allow the RNC to create a reference between the permanent NAS UE Identity of a user and the RRC connection of that user for UTRAN paging co-ordination. The procedure uses connection oriented signalling.

Successful Operation



Figure 17. Common ID procedure.

After having established an Iu signalling connection, the CN shall send a COMMON ID message, containing the *Permanent NAS UE Identity* IE to the RNC. The RNC associates the permanent identity to the RRC Connection of that user and shall save it for the duration of the RRC connection.

Abnormal Conditions

CN Invoke Trace

General

The purpose of the CN Invoke Trace procedure is to inform the RNC that it should begin producing a trace record on this particular transaction. The procedure uses the connection oriented mode signalling.

Successful Operation



Figure 18. CN Invoke Trace procedure.

The trace is invoked by the CN sending a CN INVOKE TRACE message to the UTRAN.

The events and parameters to be recorded are indicated in the *Trace Type IE*.

The *OMC ID IE*, if present, indicates the OMC to which the record is destined.

The message includes a *Trace Reference IE* which is allocated by the entity which triggered the trace.

The *Trigger ID IE*, if present, indicates the entity which triggered the trace.

The *Trace Reference* and *Trigger ID IEs* are used to tag the trace record to allow simpler construction of the total record by the entity which combines trace records.

Abnormal Conditions

Security Mode Control

General

The purpose of the Security Mode Control procedure is to allow the CN to pass cipher and integrity mode information to the UTRAN. UTRAN uses this information to select and load the encryption device for user and signalling data with the appropriate parameters, and also to store the appropriate parameters for the integrity algorithm. The procedure uses connection oriented signalling.

Successful Operation

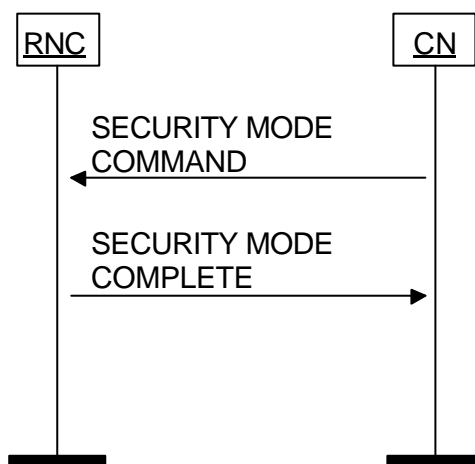

Figure 19. Security Mode Control procedure. Successful operation.

The CN shall start the procedure by sending to the UTRAN a *SECURITY MODE COMMAND* message. This message shall specify which ciphering, if any, and integrity protection algorithms that may be used by the UTRAN.

Upon reception of the *SECURITY MODE COMMAND* message, the UTRAN shall internally select appropriate algorithms, taking into account the UE/UTRAN capabilities. The UTRAN shall then trigger the execution of the corresponding radio interface procedure and, if applicable, invoke the encryption device and also start the integrity protection.

When the execution of the radio interface procedure is successfully finished, UTRAN shall return a *SECURITY MODE COMPLETE* message to the CN. This message shall include the chosen integrity protection and encryption algorithms.

The set of permitted algorithms specified in the *SECURITY MODE COMMAND* message shall remain applicable for subsequent RAB Assignments and Intra-UTRAN Relocations.

In case of a UE with Radio Access Bearers towards both core networks, the user data towards CS shall always be ciphered according to the information received from CS and the user data towards PS with the information received from PS. The signalling data shall always be ciphered with the last received ciphering information and integrity protected with the last received integrity protection information.

Unsuccessful Operation

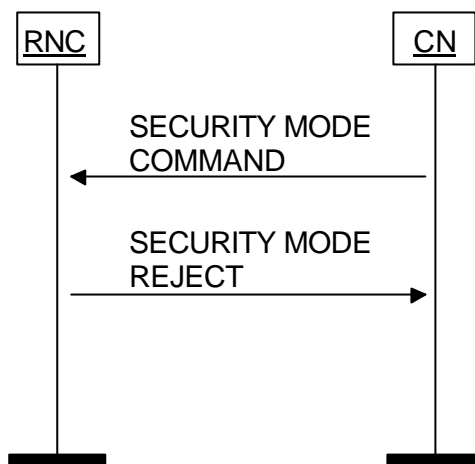

Figure 20. Security Mode Control procedure. Unsuccessful operation.

If the UTRAN or the UE is unable to support the ciphering and/or integrity protection algorithms specified in the SECURITY MODE COMMAND message, then the UTRAN shall return to CN a SECURITY MODE REJECT message with cause value "Requested Ciphering and/or Integrity Protection Algorithms are not Supported". If the radio interface Security Control Procedure fails, a SECURITY MODE REJECT message shall be sent to CN with cause value "Failure in the Radio Interface Procedure".

Abnormal Conditions

A SECURITY MODE REJECT message shall be returned if a CN requests a change of ciphering and/or integrity protection algorithms for a UE when ciphering or integrity protection is already active for that CN and such a change of algorithms is not supported by UTRAN and/or the UE. A cause value shall be set to "Change of Ciphering and/or Integrity Protection is not Supported".

Location Reporting Control

General

The purpose of the Location Reporting Control procedure is to allow the CN to request information on the location of a given UE. The procedure uses connection oriented signalling.

Successful Operation



Figure 21. Location Reporting Control procedure.

The CN shall initiate the procedure by generating a LOCATION REPORTING CONTROL message.

The *Request Type* IE shall indicate to the serving RNC whether

- to report directly,
- to report upon change of the area or
- to stop reporting.

The *Request Type* IE shall also indicate what type of location information the serving RNC shall report. The location information is either of the following types:

- Service Area Identifier or
- Geographical coordinates.

The geographical coordinates shall only be reported directly.

The valid information for the location reporting shall be the latest received from the CN.

Abnormal Conditions

Location Report

General

The purpose of the Location Report procedure is to provide the UE's location information to the CN. The procedure uses connection oriented signalling.

Successful Operation

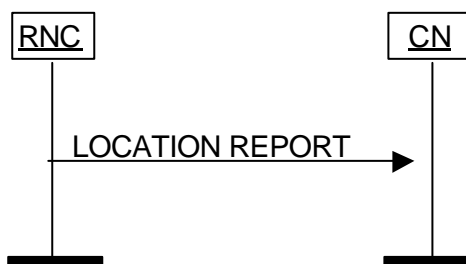

Figure 22. Location Report procedure.

The serving RNC shall initiate the procedure by generating a LOCATION REPORT message. The LOCATION REPORT message may be used as a response for the LOCATION REPORTING CONTROL message. Also, when a user enters or leaves a classified zone set by O&M, e.g. zone where a disaster occurred, a LOCATION REPORT message shall be sent to the CN including the Service Area of the UE in the *Area Identity* IE. The *Cause* IE shall indicate the appropriate cause value to CN. The CN shall react to the LOCATION REPORT message with CN vendor specific actions.

In case the reporting of Service Area Identifier is requested by the CN, then the RNC shall issue a LOCATION REPORT message whenever the information given in the previous LOCATION REPORT message or INITIAL UE MESSAGE is not anymore valid. In this case, the RNC shall include to the LOCATION REPORT message in the *Area Identity* IE the Service Area, which includes one of the cells from which the UE is consuming radio resources.

If the RNC can not deliver the location information as requested by the CN, the RNC shall indicate the UE location to be 'Undetermined'. A cause value shall be added to indicate the reason for the undetermined location.

Abnormal Conditions

Data Volume Report

General

The Data Volume Report procedure is used by CN to request the unsuccessfully transmitted DL data volume for specific RABs. This procedure only applies to PS domain. The procedure uses connection oriented signalling.

Successful Operation

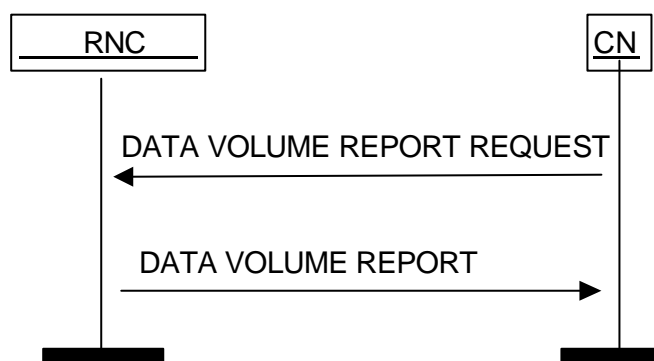

Figure 23. Data Volume Report procedure.

The procedure is initiated by CN by sending DATA VOLUME REPORT REQUEST message to UTRAN. This message shall contain the list of *RAB ID* IEs to identify the RABs for which the unsuccessfully transmitted DL data volume shall be reported.

At reception of DATA VOLUME REPORT REQUEST message UTRAN shall produce the DATA VOLUME REPORT message indicating the amount of unsuccessfully transmitted DL data for the addressed RABs since the last data volume indication to CN. UTRAN shall also reset the data volume counter for the reported RABs. UTRAN shall send the DATA VOLUME REPORT message to CN. Transmission and reception of DATA VOLUME REPORT terminates the procedure in UTRAN and CN respectively.

Unsuccessful Operation

If the RNC can not produce the report as requested, the DATA VOLUME REPORT message shall not be sent to the CN.

Abnormal Conditions

Initial UE Message

General

The purpose of the Initial UE Message procedure is to establish an Iu signalling connection between a CN domain and the RNC. The procedure uses connection oriented signalling.

Successful Operation

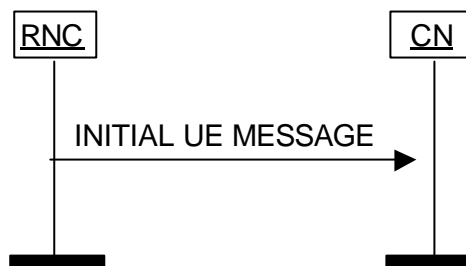

Figure 24. Initial UE Message procedure.

When RNC has received from Uu interface a NAS message to be forwarded to CN domain to which the Iu signalling connection for the UE does not exist, RNC shall initiate the Initial UE Message procedure and send the INITIAL UE MESSAGE to the CN.

In addition to the received NAS-PDU, RNC shall add following information to the INITIAL UE MESSAGE:

- CN domain indicator, indicating the CN domain towards which this message is sent.
- For CS domain, the same LAI which was the last LAI indicated to the UE by UTRAN.
- For PS domain, the same LAI+RAC which were the last LAI+RAC indicated to the UE by UTRAN.
- Service Area corresponding to the cells from which the UE is consuming radio resources.

Direct Transfer

General

The purpose of the Direct Transfer procedure is to carry UE – CN signalling messages over the Iu Interface. The UE – CN signalling messages are not interpreted by the UTRAN, and their content (e.g. MM or CC message) is outside the scope of this specification. The UE – CN signalling messages are transported as a parameter in the DIRECT TRANSFER messages. The procedure uses connection oriented signalling.

Successful Operation

CN Originated Direct Transfer



Figure 25. Direct Transfer, CN originated.

If a UE – CN signalling message has to be sent from the CN to the UE (e.g. a CC or MM message) the CN shall send a DIRECT TRANSFER message to the RNC including the UE – CN signalling message as a *NAS-PDU* IE.

The use of the SAPI included in the DIRECT TRANSFER message enables the UTRAN to provide specific service for the transport of the messages.

UTRAN Originated Direct Transfer



Figure 26. Direct Transfer, RNC originated.

If a UE – CN signalling message has to be sent from the RNC to the CN without interpretation (e.g. a CC or MM message in response to the previously sent CC or MM message from the CN) the RNC shall send a DIRECT TRANSFER message to the CN including the UE – CN signalling message as a *NAS-PDU* IE.

If the DIRECT TRANSFER message shall be sent to the PS domain, RNC shall also add the *LAI* and the *RAC* IEs, which were the last LAI+RAC indicated to the UE by UTRAN.

CN Information Broadcast

General

The purpose of the CN Information Broadcast procedure is to broadcast repetitively to all users information as provided by the core network. The procedure uses connectionless signalling.

Successful Operation

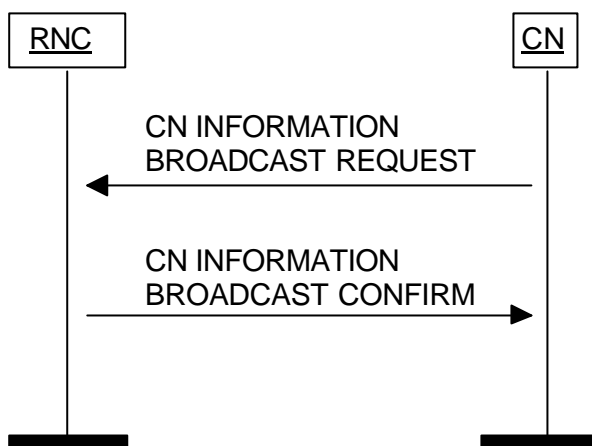

Figure 27. CN Information Broadcast procedure. Successful operation.

A core network element sets or modifies the CN broadcast information by sending a CN INFORMATION BROADCAST REQUEST message which indicates:

- The information pieces to be broadcast. The internal structure of these information pieces is transparent to UTRAN, and is specified as part of the CN-UE protocols.
- With each broadcast information, a geographical area where to broadcast it.
- With each broadcast information, some categorisation parameters to be used by the UTRAN to prioritise the broadcast information on the radio interface and determine how to schedule the repetition cycle.

If the UTRAN can broadcast the information as requested, a CN INFORMATION BROADCAST CONFIRM message is returned to the CN.

Each information piece is broadcast in the intersection between the indicated geographical area and the area under control by the receiving RNC. It is broadcast until explicitly changed or a Reset occurs. In case the ending of the broadcasting hasn't been indicated when setting the broadcasting, an empty bit string will be used to turn off the broadcasting. A CN element will run this procedure typically after each Reset, and whenever the information needs to be changed.

Unsuccessful Operation

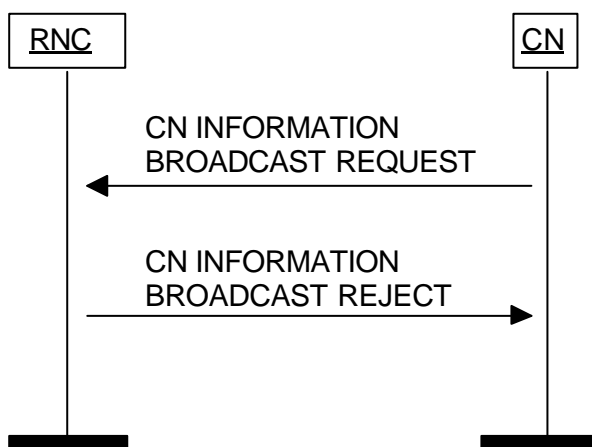

Figure 28. CN Information Broadcast procedure. Unsuccessful operation.

If after receiving the CN INFORMATION BROADCAST REQUEST, the RNC can not broadcast the information as requested, a CN INFORMATION BROADCAST REJECT message shall be returned to the CN and the procedure is terminated.

Abnormal Conditions

Overload Control

General

This procedure is defined to give some degree of signalling flow control. At the UTRAN "Processor Overload" and "Overload in the Capability to Send Signalling Messages to the UE" are catered for, and at the CN "Processor Overload" is catered for. The procedure uses connectionless signalling.

Philosophy

The philosophy used is to stem the traffic at source with known effect on the service. The algorithm used is:

At the CN side:

- If T_{igOC} is not running and an OVERLOAD message or "Signalling Point Congested" information is received, the traffic should be reduced by one step. It is also possible, optionally, to indicate the number of steps to reduce the traffic. At the same time, timers T_{igOC} and T_{inTC} should be started.
- During T_{igOC} all received OVERLOAD messages or "Signalling Point Congested" information should be ignored.
- This step by step reduction of traffic should be continued until maximum reduction is obtained by arriving at the last step.
- If T_{inTC} expires (i.e. no OVERLOAD message or "Signalling Point Congested" information is received during T_{inTC}) the traffic should be increased by one step and T_{inTC} should be started unless normal load has been resumed.

At the UTRAN side:

- If T_{igOR} is not running and an OVERLOAD message or "Signalling Point Congested" information is received, the traffic should be reduced by one step. It is also possible, optionally, to indicate the number of steps to reduce the traffic. At the same time, timers T_{igOR} and T_{inTR} should be started.
- During T_{igOR} all received OVERLOAD messages or "Signalling Point Congested" information should be ignored.
- This step by step reduction of traffic should be continued until maximum reduction is obtained by arriving at the last step.
- If T_{inTR} expires (i.e. no OVERLOAD message or "Signalling Point Congested" information is received during T_{inTR}) the traffic should be increased by one step and T_{inTR} should be started unless normal load has been resumed.

The number of steps and the method of reducing the load are considered to be an implementation specific function.

There may be other traffic control mechanisms from O&M activities occurring simultaneously.

Successful Operation

Overload at the CN

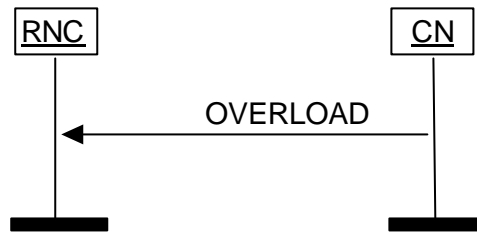

Figure 29. Overload at the CN.

The CN should indicate to the RNC that it is in a congested state by sending an OVERLOAD message.

At the UTRAN receipt of this message should cause the reduction of traffic to the CN node sending the message.

Overload at the UTRAN



Figure 30. Overload at the UTRAN.

If the UTRAN is not capable to send signalling messages to the UE due to overloaded resources then the UTRAN should send an OVERLOAD message to the CN.

Abnormal Conditions

Reset

General

The purpose of the Reset procedure is to initialise the UTRAN in the event of a failure in the CN or vice versa. The procedure uses connectionless signalling.

Successful Operation

Reset Procedure Initiated from the CN

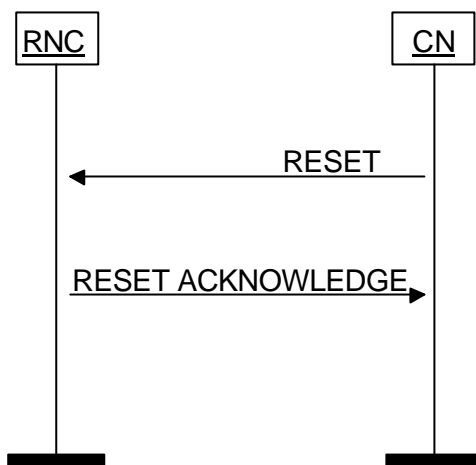

Figure 31. Reset procedure initiated from the CN. Successful operation.

In the event of a failure at the CN, which has resulted in the loss of transaction reference information, a RESET message shall be sent to the RNC. This message is used by the UTRAN to release affected Radio Access Bearers and to erase all affected references for the CN that sent the RESET message.

After a guard period of T(RatC) seconds a RESET ACKNOWLEDGE message shall be returned to the CN, indicating that all UEs which were involved in a call are no longer transmitting and that all references at the UTRAN have been cleared.

Interactions with other procedures:

In case of interactions with other procedures, the Reset procedure always overrides all other procedures.

Reset Procedure Initiated from the UTRAN

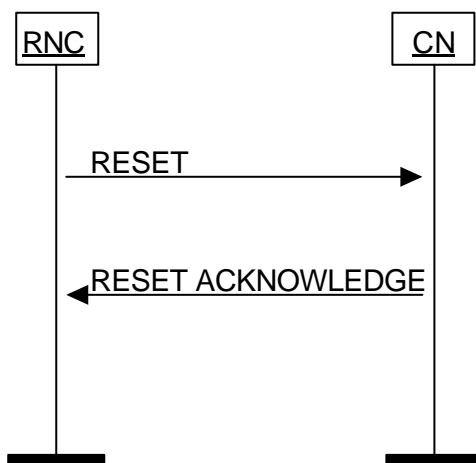

Figure 32. Reset procedure initiated from the UTRAN. Successful operation.

In the event of a failure at the UTRAN which has resulted in the loss of transaction reference information, a RESET message shall be sent to the CN. This message is used by the CN to release affected Radio Access Bearers and to erase all affected references.

After a guard period of $T(\text{RatR})$ seconds a RESET ACKNOWLEDGE message shall be returned to the UTRAN indicating that all references have been cleared.

Interactions with other procedures:

In case of interactions with other procedures, the Reset procedure always overrides all other procedures.

Abnormal Conditions

8.26.3.1 Abnormal Condition at the CN

If the CN sends a RESET message to the RNC and receives no RESET ACKNOWLEDGE message within a period $T(\text{RafR})$ then it shall repeat the entire Reset procedure. The sending of the RESET message shall be repeated a maximum of “n” times where n is an operator matter. After the n-th unsuccessful repetition the procedure shall be stopped and e.g. the maintenance system be informed.

8.26.3.2 Abnormal Condition at the UTRAN

If the RNC sends a RESET message to the CN and receives no RESET ACKNOWLEDGE message within a period $T(\text{RafC})$ then it shall repeat the entire Reset procedure. The sending of the RESET message shall be repeated a maximum of “n” times where n is an operator matter. After the n-th unsuccessful repetition the procedure shall be stopped and e.g. the maintenance system be informed.

8.26.3.3 Crossing of Reset Messages

When an entity that has sent a RESET message and is waiting for a RESET ACKNOWLEDGE message, instead receives a RESET message from the peer entity, it shall stop timer $T(\text{RafC}$ or $\text{RafR})$ and send a RESET ACKNOWLEDGE message to the peer entity.

Error Indication

General

The Error Indication procedure is initiated by a node to report detected errors in one incoming message, provided they cannot be reported by an appropriate failure message.

If the error situation arises due to reception of a message utilising dedicated signalling, then the Error Indication procedure uses connection oriented signalling. Otherwise the procedure uses connectionless signalling.

Successful Operation



Figure 33 Error Indication procedure, CN originated.



Figure 34 Error Indication procedure, RNC originated.

When the conditions defined in chapter [Handling of unknown, unforeseen and erroneous protocol data] are fulfilled, the Error Indication procedure is initiated by an ERROR INDICATION message sent from the receiving node.

When the ERROR INDICATION message is triggered due to the reception of an Iu user plane PDU(s) with an unknown Iu transport association, the appropriate cause value and both the *IU TRANSPORT ASSOCIATION IE* and the *TRANSPORT ADDRESS IE* shall be included in the message.

Examples for possible cause values for protocol error indications are:

- 'Transfer Syntax Error'
- 'Logical Error: Unknown Iu Transport Association'

Abnormal Conditions

Elements for RANAP Communication

Message Contents

Note. The messages have been defined in accordance to the guidelines specified in UMTS 25.921.

For each message there is, a table listing the signalling elements in their order of appearance in the transmitted message.

All the RANAP messages are listed in the following table:

Message name	Reference
RAB ASSIGNMENT REQUEST	9.1.1
RAB ASSIGNMENT RESPONSE	9.1.2
RAB RELEASE REQUEST	9.1.3
IU RELEASE REQUEST	9.1.4
IU RELEASE COMMAND	9.1.5
IU RELEASE COMPLETE	9.1.6
RELOCATION REQUIRED	9.1.7
RELOCATION REQUEST	9.1.8
RELOCATION REQUEST ACKNOWLEDGE	9.1.9
RELOCATION COMMAND	9.1.10
RELOCATION DETECT	9.1.11
RELOCATION COMPLETE	9.1.12
RELOCATION PREPARATION FAILURE	9.1.13
RELOCATION FAILURE	9.1.14
RELOCATION CANCEL	9.1.15
RELOCATION CANCEL ACKNOWLEDGE	9.1.16
SRNS CONTEXT REQUEST	9.1.17
SRNS CONTEXT RESPONSE	9.1.18
SRNS DATA FORWARD COMMAND	9.1.19
FORWARD SRNS CONTEXT	9.1.20
PAGING	9.1.21
COMMON ID	9.1.22
CN INVOKE TRACE	9.1.23
SECURITY MODE COMMAND	9.1.24
SECURITY MODE COMPLETE	9.1.25
SECURITY MODE REJECT	9.1.26
LOCATION REPORTING CONTROL	9.1.27
LOCATION REPORT	9.1.28
DATA VOLUME REPORT REQUEST	9.1.29
DATA VOLUME REPORT	9.1.30
INITIAL UE MESSAGE	9.1.31
DIRECT TRANSFER	9.1.32
CN INFORMATION BROADCAST REQUEST	9.1.33
CN INFORMATION BROADCAST CONFIRM	9.1.34
CN INFORMATION BROADCAST REJECT	9.1.35
OVERLOAD	9.1.36
RESET	9.1.37
RESET ACKNOWLEDGE	9.1.38
ERROR INDICATION	9.1.39

Table 1. List of RANAP messages.

All information elements in the message descriptions below are marked mandatory, optional or conditional according to the following table:

Abbreviation	Meaning
M	IE's marked as Mandatory (M) will always be included in the message.
O	IE's marked as Optional (O) may or may not be included in the message.
C	IE's marked as Conditional (C) will be included in a message only if the condition is satisfied. Otherwise the IE is not included.

Table 2. Meaning of abbreviations used in RANAP messages.

RAB ASSIGNMENT REQUEST

This message is sent by the CN to request the establishment, modification or release of one or more RABs for the same UE.

Direction: CN → RNC

Signalling bearer mode: Connection oriented.

IE/Group Name	Presence	Range	IE type and reference	Semantics description
Message Type	M		0	
RABs to be setup or modified	C – ifNoOtherGroup	0 to <maxnoofRABs>		
RAB ID	M		0	The same RAB ID must only be present in one group.
NAS Binding Information	M		0	
RAB parameters	M		0	Includes all necessary parameters for RABs (both for MSC and SGSN) including QoS.
Data Volume Reporting Indication	C - ifPS		9.2.1.17	
User Plane Information				
User Plane mode	M		9.2.1.18	
UP Mode Versions	M		9.2.1.19	
Transport Layer Address	M		9.2.2.1	
Iu Transport Association	M		9.2.2.2	
DL GTP-PDU sequence number	C- ifPS		9.2.2.3	
UL GTP-PDU sequence number	C- ifPS		9.2.2.4	
DL N-PDU sequence number	C- ifPS		9.2.1.33	
UL N-PDU sequence number	C- ifPS		9.2.1.34	
RABs to be released	C - ifNoOtherGroup	0 to <maxnoofRABs>		
RAB ID	M		0	The same RAB ID must only be present in one group.
Cause	M		9.2.1.4	

Condition	Explanation
<i>IfPS</i>	This IE is only present for RABs towards the PS domain.
<i>IfNoOtherGroup</i>	This group must be present at least when no other group is present, i.e. at least one group must be present.

Range bound	Explanation
<i>MaxnoofRABs</i>	Maximum no. of RABs for one UE. Value is 256.

RAB ASSIGNMENT RESPONSE

This message is sent by the RNC to report the outcome of the request from the message RAB ASSIGNMENT REQUEST.

Direction: RNC → CN

Signalling bearer mode: Connection oriented.

IE/Group Name	Presence	Range	IE type and reference	Semantics description
Message Type	M		0	
RABs setup or modified	C - ifNoOtherGroup	0 to <maxnoofRABs>		
RAB ID	M		0	The same RAB ID must only be present in one group.
Chosen UP Version	O		9.2.1.20	Included at least when a choice is made by UTRAN
Transport Layer Address	C - ifPS		9.2.2.1.	
lu Transport Association	C - ifPS		9.2.2.2	
RABs released	C - ifNoOtherGroup	0 to <maxnoofRABs>		
RAB ID	M		0	The same RAB ID must only be present in one group.
Data Volume	C - ifReqPS	0 to <maxnoofVol>		
Unsuccessfully Transmitted DL Data Volume	M		9.2.3.13	
Data Volume Reference	O		9.2.3.14	
DL GTP-PDU Sequence Number	C-ifUiPS		9.2.2.3	
UL GTP-PDU Sequence Number	C-ifUiPS		9.2.2.4	
RABs queued	C - ifNoOtherGroup	0 to <maxnoofRABs>		
RAB ID	M		0	The same RAB ID must only be present in one group.
RABs failed to setup or modify	C - ifNoOtherGroup	0 to <maxnoofRABs>		
RAB ID	M		0	The same RAB ID must only be present in one group.
Cause	M		9.2.1.4	
RABs failed to release	C - ifNoOtherGroup	0 to <maxnoofRABs>		
RAB ID	M		0	The same RAB ID must only be present in one group.
Cause	M		9.2.1.4.	

Condition	Explanation
-----------	-------------

<i>IfPS</i>	This IE is only present for RABs towards the PS domain.
<i>IfNoOtherGroup</i>	This group must be present at least when no other group is present, i.e. at least one group must be present.
<i>IfReqPS</i>	This IE is only present if data volume reporting for PS domain is required.
<i>IfUiPS</i>	This group is only present for RABs towards the PS domain when the release was initiated by UTRAN.

Range bound	Explanation
<i>MaxnoofRABs</i>	Maximum no. of RABs for one UE. Value is 256.
<i>MaxnoofVol</i>	Maximum no. of reported data volume for one RAB(value is 2).

RAB RELEASE REQUEST

This message is sent by the RNC, to request the CN to release one or more RABs for the same UE.

Direction: RNC → CN

Signalling bearer mode: Connection oriented.

IE/Group Name	Presence	Range	IE type and reference	Semantics description
Message Type	M		0	
RABs to be released		1 to <maxnoofRABs>		
RAB ID	M		0	
Cause	M		9.2.1.4	

Range bound	Explanation
<i>MaxnoofRABs</i>	Maximum no. of RABs for one UE. Value is 256.

IU RELEASE REQUEST

This message is sent by the RNC to request the CN to release the Iu connection.

Direction: RNC → CN

Signalling bearer mode: Connection oriented.

IE/Group Name	Presence	Range	IE type and reference	Semantics description
Message Type	M		0	
Cause	M		9.2.1.4	

IU RELEASE COMMAND

This message is sent by the CN to order RNC to release all resources related to the Iu connection.

Direction: CN → RNC

Signalling bearer mode: Connection oriented.

IE/Group Name	Presence	Range	IE type and reference	Semantics description
Message Type	M		0	
Cause	M		9.2.1.4	

IU RELEASE COMPLETE

This message is sent by the RNC as response to the IU RELEASE COMMAND message.

Direction: RNC → CN

Signalling bearer mode: Connection oriented.

IE/Group Name	Presence	Range	IE type and reference	Semantics description
Message Type	M		0	
RABs Data Volume Report	C – ifReqPS	0 to <maxnoofRABs>		
RAB ID	M		0	
Data Volume		0 to <maxnoofVol>		
Unsuccessfully Transmitted DL Data Volume	M		9.2.3.13	
Data Volume Reference	O		9.2.3.14	
RABs Released	C-ifUiPS	0 to <maxnoofRABs>		
RAB ID	M		0	
DL GTP-PDU Sequence Number	M		9.2.2.3	
UL GTP-PDU Sequence Number	M		9.2.2.4	
Criticality Diagnostics	O		9.2.1.35	

Condition	Explanation
<i>IfReqPS</i>	This Group is only present if data volume reporting for PS domain is required.
<i>IfUiPS</i>	This group is only present for RABs towards the PS domain when the release was initiated by UTRAN.

Range bound	Explanation
<i>maxnoofRABs</i>	Maximum no. of RABs for one UE. Value is 256.
<i>MaxnoofVol</i>	Maximum no. of reported data volume for one RAB. (value is 2)

RELOCATION REQUIRED

This message is sent by the source RNC to inform the CN that a relocation is to be performed.

Direction: RNC → CN

Signalling bearer mode: Connection oriented.

IE/Group Name	Presence	Range	IE type and reference	Semantics description
Message Type	M		0	
Relocation Type	M		9.2.1.23	
Cause	M		9.2.1.4	
Source ID	M		9.2.1.24	
Target ID	M		9.2.1.25	
MS Classmark 2	C - ifGSMtarget		9.2.1.26	Defined in UMTS 24.008 [8].
MS Classmark 3	C - ifGSMtarget		9.2.1.27	Defined in UMTS 24.008 [8].
Source RNC to target RNC transparent container	M		9.2.1.28	
Old BSS to new BSS Information	C - ifGSMtarget		9.2.1.29	Defined in GSM 08.08 [11].

Condition	Explanation
<i>ifGSMtarget</i>	This IE is only present when initiating an inter system handover towards GSM BSS.

RELOCATION REQUEST

This message is sent by the CN to request the target RNC to allocate necessary resources for a relocation.

Direction: CN → RNC

Signalling bearer mode: Connection oriented.

IE/Group Name	Presence	Range	IE type and reference	Semantics description
Message Type	M		0	
Permanent NAS UE Identity	C - ifAvail		0	
Cause	M		0	
CN Domain Indicator	M		9.2.1.5	
Source RNC to target RNC transparent container	M		9.2.1.28	
RABs to be setup		0 to <maxnoofRABs>		
RAB ID	M		0	
NAS Binding Information	M		0	
RAB parameters	M		0	
Data Volume Reporting Indication	C - ifPS		9.2.1.17	
User Plane Information				
User Plane mode	M		9.2.1.18	
UP Mode Versions	M		9.2.1.19	
Transport Layer Address	M		9.2.2.1	
Iu Transport Association	M		9.2.2.2	
Integrity Protection Information	M		9.2.1.11	Integrity Protection Information includes key and permitted algorithms.
Encryption Information	O		9.2.1.12	Encryption Information includes key and permitted algorithms.

Condition	Explanation
<i>ifAvail</i>	This IE is only present if available at the sending side.
<i>IfPS</i>	This IE is only present for RABs towards the PS domain.

Range bound	Explanation
<i>maxnoofRABs</i>	Maximum no. of RABs for one UE. Value is 256.

RELOCATION REQUEST ACKNOWLEDGE

This message is sent by the target RNC to inform the CN about the result of the resource allocation for the requested relocation.

Direction: RNC → CN

Signalling bearer mode: Connection oriented.

IE/Group Name	Presence	Range	IE type and reference	Semantics description
Message Type	M		0	
Target RNC to Source RNC Transparent Container	C - IfApplNotOtherCN		9.2.1.30	
RABs setup	C - ifPS	0 to <maxnoofRABs		
RAB ID	M		0	
Chosen UP Version	O		9.2.1.20	Included at least when a choice is made by UTRAN.
Transport Layer Address	M		9.2.2.1	
Iu Transport Association	M		9.2.2.2	
RABs failed to setup	C - ifNoOtherGroup	0 to <maxnoofRABs		
RAB ID	M		0	
Cause	M		0	
Chosen Integrity Protection Algorithm	M		9.2.1.13	Indicates which algorithm that will be used by the target RNC.
Chosen Encryption Algorithm	O		9.2.1.14	Indicates which algorithm that will be used by the target RNC.
Criticality Diagnostics	O		9.2.1.35	

Condition	Explanation
<i>IfPS</i>	This Group is only present for RABs towards the PS domain.
<i>IfNoOtherGroup</i>	This group must be present at least when no other group is present, i.e. at least one group must be present.
<i>IfApplNotOtherCN</i>	Must be included if applicable and if not sent via the other CN.

Range bound	Explanation
<i>maxnoofRABs</i>	Maximum no. of RABs for one UE. Value is 256.

RELOCATION COMMAND

This message is sent by the CN to source RNC to inform that resources for the relocation are allocated in target RNC.

Direction: CN → RNC

Signalling bearer mode: Connection oriented.

IE/Group Name	Presence	Range	IE type and reference	Semantics description
Message Type	M		0	
Target RNC to Source RNC Transparent Container	C - ifApplNotOtherCN		9.2.1.30	
L3 Information	C - ifGSMsource		9.2.1.31	Defined in GSM 08.08 [11].
RABs to be released		0 to <maxnoofRABs		
RAB ID	M		0	
RABs subject to data forwarding	C - ifPS	0 to <maxnoofRABs >		
RAB ID	M		0	
Transport Layer Address	M		9.2.2.1	
Iu Transport Association	M		9.2.2.2	
Criticality Diagnostics	O		9.2.1.35	

Condition	Explanation
<i>ifApplNotOtherCN</i>	Must be included if applicable and if not sent via the other CN.
<i>IfGSMsource</i>	This IE is only present when the source of an inter system handover is GSM BSS.
<i>IfPS</i>	This Group is only present for RABs towards the PS domain.

Range bound	Explanation
<i>maxnoofRABs</i>	Maximum no. of RABs for one UE. Value is 256.

RELOCATION DETECT

This message is sent by the target RNC to inform the CN that the relocation execution trigger has been received.

Direction: RNC → CN

Signalling bearer mode: Connection oriented.

IE/Group Name	Presence	Range	IE type and reference	Semantics description
Message Type	M		0	

RELOCATION COMPLETE

This message is sent by the target RNC to inform the CN that the relocation is completed.

Direction: RNC → CN

Signalling bearer mode: Connection oriented.

IE/Group Name	Presence	Range	IE type and reference	Semantics description
Message Type	M		0	

RELOCATION PREPARATION FAILURE

This message is sent by the CN to the source RNC if the relocation preparation failed.

Direction: CN → RNC

Signalling bearer mode: Connection oriented.

IE/Group Name	Presence	Range	IE type and reference	Semantics description
Message Type	M		0	
Cause	M		0	
Criticality Diagnostics	O		9.2.1.35	

RELOCATION FAILURE

This message is sent by the target RNC to inform the CN that the requested resource allocation failed.

Direction: RNC → CN

Signalling bearer mode: Connection oriented.

IE/Group Name	Presence	Range	IE type and reference	Semantics description
Message Type	M		0	
Cause	M		0	
Criticality Diagnostics	O		9.2.1.35	

RELOCATION CANCEL

This message is sent by the source RNC to the CN to cancel an ongoing relocation.

Direction: RNC → CN

Signalling bearer mode: Connection oriented.

IE/Group Name	Presence	Range	IE type and reference	Semantics description
Message Type	M		0	
Cause	M		0	

RELOCATION CANCEL ACKNOWLEDGE

This message is sent by the CN to the source RNC when the relocation has been cancelled.

Direction: CN → RNC

Signalling bearer mode: Connection oriented.

IE/Group Name	Presence	Range	IE type and reference	Semantics description
Message Type	M		0	
Criticality Diagnostics	O		9.2.1.35	

SRNS CONTEXT REQUEST

This message is sent by the CN to source RNC to indicate the PS RABs for which context transfer shall be performed.

Direction: CN → RNC

Signalling bearer mode: Connection oriented.

IE/Group Name	Presence	Range	IE type and reference	Semantics description
Message Type	M		0	
RABs subject to data forwarding		1 to <maxnoofRABs>		
RAB ID	M		0	

Range bound	Explanation
<i>maxnoofRABs</i>	Maximum no. of RABs for one UE. Value is 256.

SRNS CONTEXT RESPONSE

This message is sent by the source RNC as a response to SRNS CONTEXT REQUEST.

Direction: RNC → CN

Signalling bearer mode: Connection oriented.

IE/Group Name	Presence	Range	IE type and reference	Semantics description
Message Type	M		0	
Cause	M		0	
RABs Contexts		1 to <maxnoofRABs>		
RAB ID	M		0	
DL GTP-PDU Sequence Number	M		9.2.2.3	
UL GTP-PDU Sequence Number	M		9.2.2.4	
DL N-PDU Sequence Number	M		9.2.1.33	
UL N-PDU Sequence Number	M		9.2.1.34	
Criticality Diagnostics	O		9.2.1.35	

Range bound	Explanation
<i>maxnoofRABs</i>	Maximum no. of RABs for one UE. Value is 256.

SRNS DATA FORWARD COMMAND

This message is sent by the CN to the RNC to trigger the transfer of N-PDUs from the RNC to the CN in inter system forward handover.

Direction: CN → RNC

Signalling bearer mode: Connection oriented.

IE/Group Name	Presence	Range	IE type and reference	Semantics description
Message Type	M		0	
RABs subject to data forwarding	C - ifPS	0 to <maxnoofRABs>		
RAB ID	M		0	
Transport Layer Address	M		9.2.2.1	
lu Transport Association	M		9.2.2.2	

Condition	Explanation
<i>ifPS</i>	This Group is only present for RABs towards the PS domain.

Range bound	Explanation
<i>maxnoofRABs</i>	Maximum no. of RABs for one UE. Value is 256.

FORWARD SRNS CONTEXT

This message is sent either by source RNC to the CN or by the CN to target RNC.

Direction: CN → RNC and RNC → CN

Signalling bearer mode: Connection oriented.

IE/Group Name	Presence	Range	IE type and reference	Semantics description
Message Type	M		0	
RAB Contexts x n		1 to <maxnoofRABs>		
RAB ID	M		0	
DL GTP-PDU Sequence Number	M		9.2.2.3	
UL GTP-PDU Sequence Number	M		9.2.2.4	
DL N-PDU Sequence Number	M		9.2.1.33	
UL N-PDU Sequence Number	M		9.2.1.34	

Range bound	Explanation
<i>maxnoofRABs</i>	Maximum no. of RABs for one UE. Value is 256.

PAGING

This message is sent by the CN to request UTRAN to page a specific UE.

Direction: CN → RNC

Signalling bearer mode: Connectionless.

IE/Group Name	Presence	Range	IE type and reference	Semantics description
Message Type	M		0	
CN Domain Indicator	M		9.2.1.5	
Permanent NAS UE Identity	M		0	
Temporary UE Identity	O		9.2.3.3	
Paging Area ID	O		9.2.1.21	
Paging Cause	O		9.2.3.4	
Non Searching Indication	O		9.2.1.22	

COMMON ID

This message is sent by the CN to inform RNC about the permanent NAS UE identity for a user.

Direction: CN → RNC

Signalling bearer mode: Connection oriented.

IE/Group Name	Presence	Range	IE type and reference	Semantics description
Message Type	M		0	
Permanent NAS UE Identity (e.g. IMSI)	M		0	

CN INVOKE TRACE

This message is sent by the CN to request the RNC to start to produce a trace record.

Direction: CN → RNC

Signalling bearer mode: Connection oriented.

IE/Group Name	Presence	Range	IE type and reference	Semantics description
Message Type	M		0	
Trace Type	M		9.2.1.6	
Trace Reference	M		9.2.1.8	
Trigger ID	O		9.2.1.7	
UE Identity	O		9.2.1.9	
OMC ID	O		9.2.1.10	

SECURITY MODE COMMAND

This message is sent by the CN to trigger the integrity and ciphering functions over the radio interface.

Direction: CN → RNC

Signalling bearer mode: Connection oriented.

IE/Group Name	Presence	Range	IE type and reference	Semantics description
Message Type	M		0	
Integrity Protection Information	M		9.2.1.11	Integrity information includes key(s) and permitted algorithms.
Encryption Information	O		9.2.1.12	Encryption information includes key(s) and permitted algorithms.

SECURITY MODE COMPLETE

This message is sent by the RNC as a successful response to SECURITY MODE COMMAND.

Direction: RNC → CN

Signalling bearer mode: Connection oriented.

IE/Group Name	Presence	Range	IE type and reference	Semantics description
Message Type	M		0	
Chosen Integrity Protection Algorithm	M		9.2.1.13	
Chosen Encryption Algorithm	O		9.2.1.14	
Criticality Diagnostics	O		9.2.1.35	

SECURITY MODE REJECT

This message is sent by the RNC as a unsuccessful response to SECURITY MODE COMMAND.

Direction: RNC → CN

Signalling bearer mode: Connection oriented.

IE/Group Name	Presence	Range	IE type and reference	Semantics description
Message Type	M		0	
Cause	M		0	
Criticality Diagnostics	O		9.2.1.35	

LOCATION REPORTING CONTROL

This message is sent by the CN to initiate, modify or stop location reporting from the RNC to the CN.

Direction: CN → RNC

Signalling bearer mode: Connection oriented.

IE/Group Name	Presence	Range	IE type and reference	Semantics description
Message Type	M		0	
Request Type	M		9.2.1.16	

LOCATION REPORT

This message is sent by the RNC to the CN with information about the UE location.

Direction: RNC → CN

Signalling bearer mode: Connection oriented.

IE/Group Name	Presence	Range	IE type and reference	Semantics description
Message Type	M		0	
Area Identity	O		9.2.3.11	
Cause	O		0	

DATA VOLUME REPORT REQUEST

This message is sent by the CN to request unsuccessfully transmitted data volumes for specific RABs.

Direction: CN → RNC

Signalling bearer mode: Connection oriented.

IE/Group Name	Presence	Range	IE type and reference	Semantics description
Message Type	M		0	
RABs Data Volume Report		1 to <maxnoofRABs>		
RAB ID	M		0	

Range bound	Explanation
<i>maxnoofRABs</i>	Maximum no. of RABs for one UE. Value is 256.

DATA VOLUME REPORT

This message is sent by the RNC and informs the CN about unsuccessfully transmitted data volumes for requested RABs.

Direction: RNC → CN

Signalling bearer mode: Connection oriented.

IE/Group Name	Presence	Range	IE type and reference	Semantics description
Message Type	M		0	
RABs Data Volume Report		1 to <maxnoofRABs>		
RAB ID	M		0	
Data Volume		0 to <maxnoofVol>		
Unsuccessfully Transmitted DL Data Volume	M		9.2.3.13	
Data Volume Reference	O		9.2.3.14	
Criticality Diagnostics	O		9.2.1.35	

Range bound	Explanation
<i>maxnoofRABs</i>	Maximum no. of RABs for one UE. Value is 256.
<i>MaxnoofVol</i>	Maximum no. of reported data volume for one RAB. (value is 2)

INITIAL UE MESSAGE

This message is sent by the RNC to transfer the radio interface initial layer 3 message to the CN.

Direction: RNC → CN

Signalling bearer mode: Connection oriented.

IE/Group Name	Presence	Range	IE type and reference	Semantics description
Message Type	M		0	
CN Domain Indicator	M		9.2.1.5	
LAI	M		9.2.3.7	
RAC	C - ifPS		9.2.3.8	
SAI	M		9.2.3.10	
NAS-PDU	M		9.2.3.6	

Condition	Explanation
<i>ifPS</i>	This IE is only present for RABs towards the PS domain.

DIRECT TRANSFER

This message is sent by both the CN and the RNC and is used for carrying NAS information over the Iu interface

Direction: RNC → CN and CN → RNC

Signalling bearer mode: Connection oriented.

IE/Group Name	Presence	Range	IE type and reference	Semantics description
Message Type	M		0	
NAS-PDU	M		9.2.3.6	
LAI	C – ifPS2CN		9.2.3.7	
RAC	C – ifPS2CN		9.2.3.8	
SAPI	C – ifDL		9.2.3.9	

Condition	Explanation
<i>IfPS2CN</i>	This IE is only present if the message is directed to the PS domain.
<i>IfDL</i>	This IE is always used in downlink direction.

CN INFORMATION BROADCAST REQUEST

This message is sent by the CN and includes information to be broadcasted to all users.

Direction: CN → RNC

Signalling bearer mode: Connectionless.

IE/Group Name	Presence	Range	IE type and reference	Semantics description
Message Type	M		0	
CN Domain Indicator	M		9.2.1.5	
CN Broadcast Information piece		1 to <maxnoofPieces>		
NAS Broadcast Information	M		9.2.3.5	
Area Identity	M		9.2.3.11	
Categorisation Parameters	M		9.2.1.15	

Range bound	Explanation
<i>maxnoofPieces</i>	Maximum no. of Broadcast Information Pieces in one message. Value is 16.

CN INFORMATION BROADCAST CONFIRM

This message is sent by the RNC as a successful response to CN INFORMATION BROADCAST REQUEST.

Direction: RNC → CN

Signalling bearer mode: Connectionless.

IE/Group Name	Presence	Range	IE type and reference	Semantics description
Message Type	M		0	
CN Domain Indicator	M		9.2.1.5	
Criticality Diagnostics	O		9.2.1.35	

CN INFORMATION BROADCAST REJECT

This message is sent by the RNC as a unsuccessful response to CN INFORMATION BROADCAST REQUEST.

Direction: RNC → CN

Signalling bearer mode: Connectionless.

IE/Group Name	Presence	Range	IE type and reference	Semantics description
Message Type	M		0	
CN Domain Indicator	M		9.2.1.5	
Cause	M		0	
Criticality Diagnostics	O		9.2.1.35	

OVERLOAD

This message is sent by both the CN and the RNC to indicate that the node is overloaded.

Direction: RNC → CN and CN → RNC

Signalling bearer mode: Connectionless.

IE/Group Name	Presence	Range	IE type and reference	Semantics description
Message Type	M		0	
Number of steps	O		9.2.1.32	

RESET

This message is sent by both the CN and the RNC and is used to request that the other node shall be reset.

Direction: RNC → CN and CN → RNC

Signalling bearer mode: Connectionless.

IE/Group Name	Presence	Range	IE type and reference	Semantics description
Message Type	M		0	
Cause	M		0	
CN Domain Indicator	M		9.2.1.5	

RESET ACKNOWLEDGE

This message is sent by both the CN and the RNC as a response to RESET.

Direction: RNC → CN and CN → RNC

Signalling bearer mode: Connectionless.

IE/Group Name	Presence	Range	IE type and reference	Semantics description
Message Type	M		0	
CN Domain Indicator	M		9.2.1.5	
Criticality Diagnostics	O		9.2.1.35	

ERROR INDICATION

This message is sent by both the CN and the RNC and is used to indicate that some error has been detected in the node.

Direction: RNC → CN and CN → RNC

Signalling bearer mode: Connection oriented or connectionless.

IE/Group Name	Presence	Range	IE type and reference	Semantics description
Message Type	M		0	
Cause	C-ifalone		0	
Criticality Diagnostics	C-ifalone		9.2.1.35	
CN Domain Indicator	O		9.2.1.5	
Transport Layer Address	O		9.2.2.1	
Iu Transport Association	O		9.2.2.2	

Condition	Explanation
<i>C_ifalone</i>	At least either of Cause IE or Criticality Diagnostics IE shall be present.

Information Element Definitions

Radio Network Layer Related IEs

Message Type

Message type uniquely identifies the message being sent. It is mandatory for all messages.

IE/Group Name	Presence	Range	IE type and reference	Semantics description
Message Type	M		INTEGER (1...256)	Assumed max no of messages is 256.

RAB ID

This element uniquely identifies the radio access bearer over one Iu connection. The radio access bearer identification has only local significance in one Iu connection. The RAB ID shall remain the same for the duration of the RAB.

IE/Group Name	Presence	Range	IE type and reference	Semantics description
RAB ID	M		INTEGER (1...256)	

RAB Parameters

The purpose of the RAB parameters IE group and other parameters within the RAB parameters IE group is to indicate all RAB attributes as defined in [7] for both directions.

IE/Group Name	Presence	Range	IE type and reference	Semantics description
RAB parameters				
Traffic Class	M		ENUMERATED (conversational, streaming, interactive, background, ...)	
Maximum Bit Rate	M		INTEGER (0..16,000,000)	The unit is: bit
Guaranteed Bit Rate	M		INTEGER (0..16,000,000)	<p>The unit is: bit</p> <p>Delay and reliability attributes only apply up to the guaranteed bit rate</p> <p><u>Conditional value:</u></p> <ul style="list-style-type: none"> Set to lowest rate controllable RAB Subflow Combination rate given by the largest RAB Subflow Combination SDU size, when present and calculated periodically Set to N/A (=0) when traffic class indicates Interactive or Background

Delivery Order	M		ENUMERATED (delivery order requested, delivery order not requested)	Delivery order requested: in sequence delivery shall be guaranteed by UTRAN on all RAB SDUs Delivery order not requested: in sequence delivery is not required from UTRAN
Maximum SDU size	M		INTEGER (0..32768)	Conditional value: set to largest RAB Subflow Combination SDU size when present The unit is bit
SDU parameters		1 to <maxRABSubflows>	See below	
Transfer Delay	M		INTEGER (0..65535)	Delay attribute Unit is millisecond. Set to N/A (65535) when traffic class is set interactive or background.
Traffic Handling priority	M		INTEGER (spare (0), highest (1), lowest (14), no priority used (15)) (0..15)	<u>Conditional value</u> : set to N/A (=0) for all traffic classes except "Interactive"
Allocation/Retention priority	M		See below	
Source Statistics descriptor	M		ENUMERATED (N/A, speech, unknown, ...)	<u>Conditional value</u> : set to N/A when traffic class is set to Interactive or Background

Range Bound	Explanation
MaxRABSubflows	Number of RAB Subflows

IE/Group Name	Presence	Range	IE type and reference	Semantics description
SDU parameters				
Choice SDU Error Ratio	M			Reliability attribute Conditional value: set to N/A (=1) when the Delivery of Erroneous SDU is set to "-"
NULL				
SDU Error Ratio				
Mantissa	M		INTEGER (1..9)	
Exponent	M		INTEGER (1..6)	
Choice Residual Bit Error Ratio	M			Reliability attribute
NULL				
Residual Bit Error Ratio				
Mantissa	M		INTEGER (1..9)	
Exponent	M		INTEGER (1..8)	

Delivery of Erroneous SDU	M		ENUMERATED (yes, no, -)	Reliability attribute Yes: error detection applied, erroneous SDU delivered No. Error detection is applied , erroneous SDU discarded -: SDUs delivered without considering error detection
Subflow SDU size Parameter	M	1 to <maxRABSubflow Combination>	INTEGER (0..4095)	

Range Bound	Explanation
MaxRABSubflowCombination	Number of RAB Subflow Combination

IE/Group Name	Presence	Range	IE type and reference	Semantics description
Subflow SDU size Parameter				
Rate Control allowed	M		ENUMERATED (not allowed, allowed)	Conditions on the horizontal setting. The rate control is set identical to all SDU format information of the same RAB SubFlow Combination
Subflow SDU size	O		INTEGER (0...4095)	This IE is only present for RABs that have predefined SDU size(s)

IE/Group Name	Presence	Range	IE type and reference	Semantics description
Allocation/Retention priority				
Priority level	M		Integer {sparse (0), highest (1), lowest (14), no priority used (15)} (0..15)	
Pre-emption Capability	M		ENUMERATED (cannot trigger pre-emption, can trigger pre-emption)	The RAB shall not pre-empt, The RAB may pre-empt
Pre-emption Vulnerability	M		ENUMERATED (not vulnerable to pre-emption, vulnerable to pre-emption)	The RAB shall not be pre-empted, The RAB might be pre-empted
Queuing allowed	M		ENUMERATED (queueing not allowed, queueing allowed)	Queuing of the RAB is allowed Queuing of the RAB is not allowed

Cause

The purpose of the cause information element is to indicate the reason for a particular event for the RANAP protocol.

IE/Group Name	Presence	Range	IE type and reference	Semantics description
Cause group	M		ENUMERATED (Radio Network Layer, Transport Layer, NAS, Protocol, Miscellaneous, Non-standard, ...)	
CHOICE <i>Cause group</i>				
<i>Radio Network Layer</i>				
Radio Network Layer Cause	O	1 to 64	INTEGER (RAB pre-empted, Trelcoverall Expiry, Trelcprep Expiry, Trelccomplete Expiry, Tqueing Expiry, Relocation Triggered, Unable to Establish During Relocation, Unknown Target RNC, Relocation Cancelled, Successful Relocation, Requested Ciphering and/or Integrity Protection Algorithms not Supported, Change of Ciphering and/or Integrity Protection is not supported, Failure in the Radio Interface Procedure, Release due to UTRAN Generated Reason, User Inactivity,	

			<p>Time Critical Relocation,</p> <p>Requested Traffic Class not Available,</p> <p>Invalid RAB Parameters Value,</p> <p>Requested Maximum Bit Rate not Available,</p> <p>Requested Guaranteed Bit Rate not Available,</p> <p>Requested Transfer Delay not Achievable,</p> <p>Invalid RAB Parameters Combination,</p> <p>Condition Violation for SDU Parameters,</p> <p>Condition Violation for Traffic Handling Priority,</p> <p>Condition Violation for Guaranteed Bit Rate,</p> <p>User Plane Versions not Supported,</p> <p>Iu UP Failure,...)</p>	
--	--	--	--	--

<i>Transmission Network</i>				
Transport Layer Cause	O	65 to 80	INTEGER (Logical Error: Unknown lu Transport Association,...)	
<i>NAS</i>				
NAS Cause	O	81 to 96	INTEGER (User Restriction Start Indication, User Restriction End Indication, Normal Release, ...)	
<i>Protocol</i>				
Protocol Cause	O	97 to 112	INTEGER (Transfer Syntax Error, ...)	
<i>Miscellaneous</i>				
Miscellaneous Cause	O	113 to 128	INTEGER (O&M Intervention, No Resource Available, Unspecified Failure, Network Optimisation, ...)	
<i>Non-standard</i>				
Non-standard Cause	O	129 to 256	INTEGER (...)	

CN Domain Indicator

Indicates the CN domain from which the message originates or to which the message shall be sent.

IE/Group Name	Presence	Range	IE type and reference	Semantics description
CN Domain Indicator	M		ENUMERATED (CS domain, PS domain)	

Trace Type

A fixed length element indicating the type of trace information to be recorded.

IE/Group Name	Presence	Range	IE type and reference	Semantics description
Trace Type	M		OCTET STRING (1)	Coded as the Trace Type specified in UMTS TS based on GSM TS 12.08 [12].

Trigger ID

A variable length element indicating the identity of the entity which initiated the trace.

IE/Group Name	Presence	Range	IE type and reference	Semantics description
Trigger ID	M		OCTET STRING (3..22)	Typically an OMC identity.

Trace Reference

A fixed length element providing a trace reference number allocated by the triggering entity.

IE/Group Name	Presence	Range	IE type and reference	Semantics description
Trace Reference	M		OCTET STRING (2..3)	

UE Identity

This element identifies the element to be traced i.e. the subscriber or the user equipment.

IE/Group Name	Presence	Range	IE type and reference	Semantics description
Choice UE Identity	M			
IMSI			OCTET STRING (SIZE (3..8))	<ul style="list-style-type: none"> - digits 0 to 9, two digits per octet, - each digit encoded 0000 to 1001, - 1111 used as filler - bit 4 to 1 of octet n encoding digit 2n-1 - bit 8 to 5 of octet n encoding digit 2n <p>-Number of decimal digits shall be from 6 to 15 starting with the digits from the PLMN-ID.</p>
IMEI			OCTET STRING (SIZE (8))	<ul style="list-style-type: none"> - digits 0 to 9, two digits per octet, - each digit encoded 0000 to 1001, - 1111 used as filler - bit 4 to 1 of octet n encoding digit 2n-1 - bit 8 to 5 of octet n encoding digit 2n <p>Number of decimal digits shall be 15.</p>

OMC ID

A variable length element indicating the destination address of the Operation and Maintenance Center (OMC) to which trace information is to be sent.

IE/Group Name	Presence	Range	IE type and reference	Semantics description
OMC ID	M		OCTET STRING (3..22)	Coded as the OMC ID specified in UMTSTS based on GSM TS 12.20.

Integrity Protection Information

This element contains the integrity protection information (key(s) and permitted algorithms).

IE/Group Name	Presence	Range	IE type and reference	Semantics description
Integrity Protection Information				
Permitted integrity Protection Algorithms				
Integrity Protection Algorithm	M	1 to 15	INTEGER (standard UIA1 (0))	Range is 0 to 15. Only one value used.
Integrity Protection Key	M		BIT STRING (128)	

Encryption Information

This element contains the user data encryption information (key(s) and permitted algorithms) used to control any encryption equipment at the RNC.

IE/Group Name	Presence	Range	IE type and reference	Semantics description
Encryption Information				
Permitted Encryption Algorithms				
Encryption Algorithm	M	0 to 15	INTEGER (no encryption (0), standard UEA1 (1))	Range is 0 to 15. Only two values used.
Encryption Key	M		Bit string (128)	

Chosen Integrity Protection Algorithm

This element indicates the integrity protection algorithm being used by the RNC.

IE/Group Name	Presence	Range	IE type and reference	Semantics description
Chosen Integrity Protection Algorithm	M		INTEGER (standard UIA1 (0))	Range is 0 to 15. Only one value used.

Chosen Encryption Algorithm

This element indicates the encryption algorithm being used by the RNC.

IE/Group Name	Presence	Range	IE type and reference	Semantics description
Chosen Encryption Algorithm	M		INTEGER (no encryption (0), standard UEA1 (1))	Range is 0 to 15. Only two values used.

Categorisation Parameters

With each NAS Broadcast Information, this element is used by the RNC to determine how to prioritise the information and schedule the repetition cycle.

IE/Group Name	Presence	Range	IE type and reference	Semantics description
Categorisation Parameters	M		INTEGER	Range 0..15.

Request Type

This element indicates the type of UE location to be reported from RNC and it is either a Service Area or geographical coordinates.

IE/Group Name	Presence	Range	IE type and reference	Semantics description
Request Type				
Event	M		ENUMERATED(Stop, Direct, Change of area, ...)	
Report area	M		ENUMERATED(Service Area, Geographical Coordinates, ...)	

Data Volume Reporting Indication

This information element indicates whether or not RNC has to calculate the unsuccessfully transmitted NAS data amount for the RAB and to report the amount of data when the RAB is released.

IE/Group Name	Presence	Range	IE type and reference	Semantics description
Data Volume Reporting Indication	M		ENUMERATED (do report, do not report)	

User Plane Mode

This element indicates the mode of operation of the Iu User plane requested for realising the RAB. The Iu user plane modes are defined in UMTS 25.415 [6].

IE/Group Name	Presence	Range	IE type and reference	Semantics description
User Plane Mode	M		ENUMERATED (transparent mode, support mode for predefined SDU sizes, ...)	This IE contains the mode of operation of the Lu UP protocol

UP Mode Versions

UP mode versions IE is an information element that is sent by CN to RNC. It is a bit string that indicates the versions for the selected UP mode that are supported by the CN.

IE/Group Name	Presence	Range	IE type and reference	Semantics description
UP Mode Versions	M		BIT STRING (16)	Indicates the versions of the selected UP mode that are supported by the CN Bit 0 set to '1' equals version 1 Bit 1 set to '1' equals version 2 ...

Chosen UP Version

Chosen UP version IE is an information element that is sent by RNC to CN. It indicates which version of the given UP mode the RNC selected to be used.

IE/Group Name	Presence	Range	IE type and reference	Semantics description
Chosen UP Version	M		INTEGER (1..16)	It indicates the version of the UP mode the RNC selected. Value 1 equals version 1 ... Value 16 equals value 16

Paging Area ID

This element uniquely identifies the area, where the PAGING message shall be broadcasted. The Paging area ID is either a Location Area ID or Routing Area ID.

IE/Group Name	Presence	Range	IE type and reference	Semantics description
Choice Paging Area ID				
LAI			9.2.3.7	
RAI				
LAI	M		9.2.3.7	
RAC	M		9.2.3.8	

Non Searching Indication

This parameter allows the RNC not to search Common ID when receiving a PAGING message from the CN.

IE/Group Name	Presence	Range	IE type and reference	Semantics description
Non Searching Indication	M		ENUMERATED (non-searching, searching)	

Relocation Type

This information element indicates whether the relocation of SRNS is to be executed with or without involvement of the UE. If the UE is involved then a Uu interface handover command shall be sent to the UE to trigger the execution of the relocation. If the UE is not involved then the relocation execution is triggered via Iur.

IE/Group Name	Presence	Range	IE type and reference	Semantics description
Relocation Type	M		ENUMERATED (UE not involved in relocation of SRNS, UE involved in relocation of SRNS)	

Source ID

Source ID identifies the source for the relocation of SRNS. The Source ID may be e.g. Source RNC-ID or serving cell ID.

IE/Group Name	Presence	Range	IE type and reference	Semantics description
Choice Source ID	M			
Source RNC-ID	C - ifUMTStarget			
PLMN-ID	M		OCTET STRING (SIZE (3))	<ul style="list-style-type: none"> - digits 0 to 9, two digits per octet, - each digit encoded 0000 to 1001, - 1111 used as filler - bit 4 to 1 of octet n encoding digit 2n-1 - bit 8 to 5 of octet n encoding digit 2n <p>-The PLMN-ID consists of 3 digits from MCC followed by either</p> <ul style="list-style-type: none"> -a filler plus 2 digits from MNC (in case of 2 digit MNC) or -3 digits from MNC (in case of a 3 digit MNC).
RNC-ID	M		INTEGER (0..4095)	
SAI	C - ifGSMtarget			

Target ID

Target ID identifies the target for the relocation of SRNS. The target ID may be e.g. Target RNC-ID (for UMTS-UMTS relocation) or Cell Global ID of the relocation target (in case of UMTS to GSM relocation).

IE/Group Name	Presence	Range	IE type and reference	Semantics description
Choice Target ID	M			
Target RNC-ID				
PLMN-ID	M		OCTET STRING (SIZE (3))	<ul style="list-style-type: none"> - digits 0 to 9, two digits per octet, - each digit encoded 0000 to 1001, - 1111 used as filler - bit 4 to 1 of octet n encoding digit 2n-1 - bit 8 to 5 of octet n encoding digit 2n <p>-The PLMN-ID consists of 3 digits from MCC followed by either</p> <ul style="list-style-type: none"> -a filler plus 2 digits from MNC (in case of 2 digit MNC) or -3 digits from MNC (in case of a 3 digit MNC).
RNC-ID	M		INTEGER (0..4095)	
CGI				
PLMN-ID	M		OCTET STRING (SIZE (3))	<ul style="list-style-type: none"> - digits 0 to 9, two digits per octet, - each digit encoded 0000 to 1001, - 1111 used as filler - bit 4 to 1 of octet n encoding digit 2n-1 - bit 8 to 5 of octet n encoding digit 2n <p>-The PLMN-ID consists of 3 digits from MCC followed by either</p> <ul style="list-style-type: none"> -a filler plus 2 digits from MNC (in case of 2 digit MNC) or -3 digits from MNC (in case of a 3 digit MNC).
LAC	M		OCTET STRING (2)	0000 and FFFE not allowed.
CI	M		OCTET STRING (2)	

MS Classmark 2

The coding of this element is described in 24.008 [8].

IE/Group Name	Presence	Range	IE type and reference	Semantics description
MS Classmark 2	M		OCTET STRING	Contents defined in TS 24.008 [8]

MS Classmark 3

The coding of this element is described in 24.008 [8].

IE/Group Name	Presence	Range	IE type and reference	Semantics description
MS Classmark 3	M		OCTET STRING	Contents defined in TS 24.008 [8]

Source RNC to Target RNC Transparent Container

Source RNC to Target RNC Transparent Container IE is an information element that is produced by Source RNC and is transmitted to target RNC. In inter system relocation the IE is transmitted either from external relocation source to target RNC or from source RNC to the external relocation target.

This IE is transparent to CN.

IE/Group Name	Presence	Range	IE type and reference	Semantics description
RRC Container	M		OCTET STRING	Contents defined in TS 25.331 [10]
Number of lu Instances	M		INTEGER (1...2)	
Relocation Type	M		9.2.1.23	
Chosen Integrity Protection Algorithm	C - ifIntraUMTS		9.2.1.13	Indicates which integrity protection algorithm that has been used by the source RNC.
Integrity Protection Key	C - ifIntraUMTS		Bit String (128)	Indicates which integrity protection key that has been used by the source RNC.
Chosen Encryption Algorithm	C - ifIntraUMTSandCiph		9.2.1.14	Indicates which algorithm that has been used by the source RNC for ciphering of signalling data.
Ciphering Key	C - ifIntraUMTSandCiph		Bit String (128)	Indicates which ciphering key that has been used by the source RNC for ciphering of signalling data.
Chosen Encryption Algorithm	C - ifIntraUMTSandCiph		9.2.1.14	Indicates which algorithm that has been used by the source RNC for ciphering of CS user data.
Chosen Encryption Algorithm	C - ifIntraUMTSandCiph		9.2.1.14	Indicates which algorithm that has been used by the source RNC for ciphering of PS user data.
d-RNTI	O		INTEGER (0..1048575)	

Condition	Explanation
<i>IfIntraUMTS</i>	Must be present for intra UMTS Handovers
<i>IfIntraUMTSandCiph</i>	Must be present for intra UMTS Handovers if ciphering is active

Old BSS to New BSS Information

The coding of this element is described in GSM 08.08 [11].

IE/Group Name	Presence	Range	IE type and reference	Semantics description
Old BSS to New BSS Information	M		OCTET STRING	Contents defined in GSM 08.08 [11].

Target RNC to Source RNC Transparent Container

Target RNC to Source RNC Transparent Container IE is an information element that is produced by Target RNC and is transmitted to Source RNC. In inter system relocation the IE is transmitted either from external relocation target to source RNC or from target RNC to the external relocation source.

This IE is transparent to CN.

IE/Group Name	Presence	Range	IE type and reference	Semantics description
RRC Container	M		OCTET STRING	Contents defined in TS 25.331 [10]

L3 Information

The coding of this element is described in GSM 08.08 [11].

IE/Group Name	Presence	Range	IE type and reference	Semantics description
L3 Information	M		OCTET STRING	Contents defined in GSM 08.08 [11].

Number of Steps

Indicates the number of steps to reduce traffic in overload situation.

IE/Group Name	Presence	Range	IE type and reference	Semantics description
Number of Steps	M		INTEGER (1...16)	

DL N-PDU Sequence Number

This IE indicates the Uu interface sequence number (PDCP) of the next downlink N-PDU (PDCP PDU) that would have been sent to the UE by a source system.

IE/Group Name	Presence	Range	IE type and reference	Semantics description
DL N-PDU Sequence Number	M		INTEGER (0..4095)	This IE indicates the sequence number of the next DL N-PDU that would have been sent to the UE by a source system. This is the 12 bit sequence number.

UL N-PDU Sequence Number

This IE indicates the Uu interface sequence number (PDCP) of the next uplink N-PDU (PDCP PDU) that would have been expected from the UE by a source system.

IE/Group Name	Presence	Range	IE type and reference	Semantics description
UL N-PDU Sequence Number	M		INTEGER (0..4095)	This IE indicates the sequence number of the next UL N-PDU that would have been expected from the UE by a source system. This is the 12 bit sequence number.

Criticality Diagnostics IE

IE/Group Name	Presence	Range	IE type and reference	Semantics description
Criticality Diagnostics				
Procedure Code	O		INTEGER (0..255)	Procedure code is to be used if Criticality diagnostics is part of Error Indication procedure, and not within the response message of the same operation that caused the error
Triggering Message	O		ENUMERATED (initiating message, successful outcome, unsuccessful outcome)	The Triggering Message is used only if the Criticality diagnostics is part of Error Indication procedure except when the procedure code is not understood.
Criticality Response	O		ENUMERATED (reject, ignore, notify)	This Criticality response IE is used for reporting the Criticality of the Triggering message
Information Element Criticality Diagnostics		0 to <maxnoof errors>		
Criticality Response	M		ENUMERATED (reject, ignore, notify)	The Criticality response IE is used for reporting the criticality of the triggering IE. The value 'ignore' shall not be used.
IE Id	M		INTEGER (0..65535)	The IE Id of the not understood IE

Range bound	Explanation
<i>maxnooferrors</i>	Maximum no. of IE errors allowed to be reported with a single message. The value for maxnooferrors is 256.

Transport Network Layer Related IEs

Transport Layer Address

For the PS domain this information element is an IP address to be used for the user plane transport. For the CS domain this address is to be used for Transport Network Control Plane signalling to set up the U-Plane connection.

IE/Group Name	Presence	Range	IE type and reference	Semantics description
Transport Layer Address	M		OCTET STRING (20)	The Radio Network layer is not supposed to interpret the address information. It should pass it to the transport layer for interpretation. For details on the Transport Layer Address, see ref. 25.414 [9].

Iu Transport Association

This element is used to associate the RAB and the corresponding user plane connection. For the CS domain this information element is the Binding ID to be used in Transport Network Control Plane signalling during set up of the U-Plane connection. In PS domain this information element is the GTP Tunnel Endpoint Identifier.

IE/Group Name	Presence	Range	IE type and reference	Semantics description
Choice Iu transport association				
GTP TEID	C – ifPS		OCTET STRING (4)	
Binding ID	C - ifCS		OCTET STRING (4)	

Condition	Explanation
<i>IfPS</i>	This IE is only present for RABs towards the PS domain.
<i>IfCS</i>	This IE is only present for RABs towards the CS domain.

DL GTP-PDU Sequence Number

This IE indicates the sequence number of the GTP-PDU which is the next to be sent to the UE.

IE/Group Name	Presence	Range	IE type and reference	Semantics description
DL GTP-PDU Sequence Number	M		INTEGER (0..65535)	This IE indicates the sequence number of the GTP-PDU which is next to be sent to the UE.

UL GTP-PDU Sequence Number

This IE indicates the sequence number of the GTP-PDU which is the next to be sent to the SGSN.

IE/Group Name	Presence	Range	IE type and reference	Semantics description
UL GTP-PDU Sequence Number	M		INTEGER (0 ..65535)	This IE indicates the sequence number of the GTP-PDU which is next to be sent to the SGSN.

NAS Related IEs

NAS Binding Information

This element contains application specific information, to be used by the remote NAS entity at the UE side. It serves as the binding to a NAS call. This element is transparent to the RNC.

IE/Group Name	Presence	Range	IE type and reference	Semantics description
NAS Binding Information	M		OCTET STRING (2)	

Permanent NAS UE Identity

This element is used to identify the UE commonly in UTRAN and in CN. RNC uses to find other existing signalling connections of this same UE (e.g. RRC or Iu signalling connections) Initially this is of the type of IMSI.

Note: IMSI is specified in the TS 23.003.

IE/Group Name	Presence	Range	IE type and reference	Semantics description
Choice Permanent NAS UE Identity	M			
IMSI			OCTET STRING (SIZE (3..8))	<ul style="list-style-type: none"> - digits 0 to 9, two digits per octet, - each digit encoded 0000 to 1001, - 1111 used as filler - bit 4 to 1 of octet n encoding digit 2n-1 - bit 8 to 5 of octet n encoding digit 2n <p>-Number of decimal digits shall be from 6 to 15 starting with the digits from the PLMN-ID.</p>

Temporary UE ID

Temporary Mobile Subscriber Identity, used for security reasons to hide the identity of a subscriber.

IE/Group Name	Presence	Range	IE type and reference	Semantics description
Choice Temporary UE ID				
TMSI	M		OCTET STRING (4)	
P-TMSI	M		OCTET STRING (4)	

Paging Cause

This element indicates the cause of paging to the UE.

IE/Group Name	Presence	Range	IE type and reference	Semantics description
Paging cause	M		ENUMERATED(speech call, CS data call, PS data call, SMS, ...)	

NAS Broadcast Information

This element identifies broadcast information that belongs to the non-access stratum (e.g. LAC, RA code etc). This information is transparent to RNC.

IE/Group Name	Presence	Range	IE type and reference	Semantics description
NAS Broadcast Information	M		OCTET STRING	

NAS PDU

This information element contains the CN – UE or UE – CN message that is transferred without interpretation in the RNC. Typically it contains call control, session management, supplementary services, short message service and mobility management messages.

IE/Group Name	Presence	Range	IE type and reference	Semantics description
NAS PDU	M		OCTET STRING	

LAI

This element is used to uniquely identify a Location Area.

IE/Group Name	Presence	Range	IE type and reference	Semantics description
LAI				
PLMN-ID	M		OCTET STRING (SIZE (3))	<ul style="list-style-type: none"> - digits 0 to 9, two digits per octet, - each digit encoded 0000 to 1001, - 1111 used as filler - bit 4 to 1 of octet n encoding digit 2n-1 - bit 8 to 5 of octet n encoding digit 2n <p>-The PLMN-ID consists of 3 digits from MCC followed by either</p> <ul style="list-style-type: none"> -a filler plus 2 digits from MNC (in case of 2 digit MNC) or -3 digits from MNC (in case of a 3 digit MNC).
LAC	M		OCTET STRING (2)	0000 and FFFE not allowed.

RAC

This element is used to identify a Routing Area within a Location Area. It is used for PS services.

IE/Group Name	Presence	Range	IE type and reference	Semantics description
RAC	M		OCTET STRING (1)	

SAPI

The SAPI element is used to indicate the specific service provided for the message.

IE/Group Name	Presence	Range	IE type and reference	Semantics description
SAPI	M		ENUMERATED (SAPI 0, SAPI 3, ...)	

SAI

Service Area Identifier (SAI) information element is used to uniquely identify an area consisting of one or more cells belonging to the same Location Area. Such an area is called a Service Area and can be used for indicating the location of a UE to the CN.

IE/Group Name	Presence	Range	IE type and reference	Semantics description
SAI				
PLMN-ID	M		OCTET STRING (SIZE (3))	<ul style="list-style-type: none"> - digits 0 to 9, two digits per octet, - each digit encoded 0000 to 1001, - 1111 used as filler - bit 4 to 1 of octet n encoding digit 2n-1 - bit 8 to 5 of octet n encoding digit 2n <p>-The PLMN-ID consists of 3 digits from MCC followed by either</p> <ul style="list-style-type: none"> -a filler plus 2 digits from MNC (in case of 2 digit MNC) or -3 digits from MNC (in case of a 3 digit MNC).
LAC	M		OCTET STRING (2)	0000 and FFFE not allowed.
SAC	M		OCTET STRING (2)	

Area Identity

This information element is used for indicating the location of a UE and is either a Service Area or Geographical Area

IE/Group Name	Presence	Range	IE type and reference	Semantics description
Choice Area Identity				
SAI			9.2.3.10	
Geographical Area			9.2.3.12	

Geographical Area

Geographical Area is used to identify an area, as seen from the CN, using geographical coordinates. The reference system is the same as the one used in UMTS 23.032.

IE/Group Name	Presence	Range	IE type and reference	Semantics description
Choice Geographical Area				
Point			See below	Ellipsoid point
Point with uncertainty			See below	Ellipsoid point with uncertainty circle
Polygon			See below	List of Ellipsoid points

IE/Group Name	Presence	Range	IE type and reference	Semantics description
Point				
Geographical Coordinates	M		See below	

IE/Group Name	Presence	Range	IE type and reference	Semantics description
Point with uncertainty				
Geographical Coordinates	M		See below	
Uncertainty Code			INTEGER(0...127)	The uncertainty "r" is derived from the "uncertainty code" k by $r = 10 \times (1.1^k - 1)$

IE/Group Name	Presence	Range	IE type and reference	Semantics description
Polygon	M			
Geographical Coordinates	M	1 to <maxnoofPoints>	See below	

Range bound	Explanation
<i>maxnoofPoints</i>	Maximum no. of points in polygon. Value is 15.

IE/Group Name	Presence	Range	IE type and reference	Semantics description
Geographical Coordinates				
Latitude Sign	M		ENUMERATED (North, South)	
Degrees of Latitude	M		INTEGER (0... $2^{23}-1$)	The IE value (N) is derived by this formula: $N \leq 2^{23} \times /90 < N+1$ X being the latitude in degree (0°.. 90°)
Degrees of Longitude	M		INTEGER (- 2^{23} ... $2^{23}-1$)	The IE value (N) is derived by this formula: $N \leq 2^{24} \times /360 < N+1$ X being the longitude in degree (-180°..+180°)

Unsuccessfully Transmitted Data Volume

This information element indicates the data volume (octets) that is unsuccessfully transmitted over the radio interface in DL direction for the RAB.

IE/Group Name	Presence	Range	IE type and reference	Semantics description
Unsuccessfully Transmitted Data Volume	M		INTEGER (0.. $2^{32}-1$)	Unit is octet.

Data Volume Reference

This information element indicates the time when the data volume is counted.

IE/Group Name	Presence	Range	IE type and reference	Semantics description
Data Volume Reference	O		INTEGER (0..255)	

RANAP Information used in non-RANAP Protocols

RANAP Relocation Information

The *RANAP Relocation Information* IE is transmitted from source to target RNC in the RNSAP message RELOCATION COMMIT.

IE/Group Name	Presence	Range	IE type and reference	Semantics description
RANAP Relocation Information				
Direct Transfer Information		0 to <MaxnoofDT>		Information received in one or more DIRECT TRANSFER messages and that needs to be transferred to target RNC for further transmission to the UE.
NAS-PDU	M		9.2.3.6	
SAPI	M		9.2.3.9	
RAB Contexts		0 to <maxnoofRABs>		
NAS Binding Information	M		9.2.3.1	
DL GTP-PDU Sequence Number	M		9.2.2.3	
UL GTP-PDU Sequence Number	M		9.2.2.4	
DL N-PDU Sequence Number	M		9.2.1.33	
UL N-PDU Sequence Number	M		9.2.1.34	

Range bound	Explanation
<i>maxnoofDT</i>	Maximum no. of DT information. Value is 15.

Message and Information Element Abstract Syntax (with ASN.1)

Usage of protocol extension mechanism for non-standard use

The protocol extension mechanism for non-standard use may be used

- for special operator- (and/or vendor) specific features considered not to be part of the basic functionality, i.e. the functionality required for a complete and high-quality specification in order to guarantee multivendor interoperability.
- by vendors for research purposes, e.g. to implement and evaluate new algorithms/features before such features are proposed for standardisation

The extension mechanism shall not be used for basic functionality. Such functionality shall be standardised.

Elementary Procedure Definitions

```
-- *****
--
-- Elementary Procedure definitions
--
-- *****

RANAP-PDU-Descriptions -- { object identifier to be allocated }--
DEFINITIONS AUTOMATIC TAGS ::=

BEGIN

-- *****
--
-- IE parameter types from other modules.
--
-- *****

IMPORTS

    Criticality,
    ProcedureCode
FROM RANAP-CommonDataTypes

    Iu-ReleaseCommand,
```

Iu-ReleaseComplete,
RelocationCommand,
RelocationPreparationFailure,
RelocationRequired,
RelocationRequest,
RelocationRequestAcknowledge,
RelocationFailure,
RelocationCancel,
RelocationCancelAcknowledge,
SRNS-ContextRequest,
SRNS-ContextResponse,
SecurityModeCommand,
SecurityModeComplete,
SecurityModeReject,
DataVolumeReportRequest,
DataVolumeReport,
CN-InformationBroadcastRequest,
CN-InformationBroadcastConfirm,
CN-InformationBroadcastReject,
Reset,
ResetAcknowledge,
RAB-ReleaseRequest,
Iu-ReleaseRequest,
RelocationDetect,
RelocationComplete,
Paging,
CommonID,
CN-InvokeTrace,
LocationReportingControl,
LocationReport,
InitialUE-Message,
DirectTransfer,
Overload,
ErrorIndication,
SRNS-DataForwardCommand,
ForwardSRNS-Context,
RAB-AssignmentRequest,
RAB-AssignmentResponse,
PrivateMessage

FROM RANAP-PDU-Contents

id-CN-InformationBroadcast,
id-CN-InvokeTrace,
id-CommonID,
id-DataVolumeReport,
id-DirectTransfer,
id-ErrorIndication,

```

-- Interface PDU Definition
--
-- *****

RANAP-PDU ::= CHOICE {
    initiatingMessage      InitiatingMessage,
    successfulOutcome      SuccessfulOutcome,
    unsuccessfulOutcome    UnsuccessfulOutcome,
    outcome                Outcome,
    ...
}

InitiatingMessage ::= SEQUENCE {
    procedureCode          RANAP-ELEMENTARY-PROCEDURE.&procedureCode      ( {RANAP-ELEMENTARY-PROCEDURES} ),
    criticality            RANAP-ELEMENTARY-PROCEDURE.&criticality          ( {RANAP-ELEMENTARY-
PROCEDURES}{@procedureCode} ),
    value                  RANAP-ELEMENTARY-PROCEDURE.&InitiatingMessage    ( {RANAP-ELEMENTARY-
PROCEDURES}{@procedureCode} )
}

SuccessfulOutcome ::= SEQUENCE {
    procedureCode          RANAP-ELEMENTARY-PROCEDURE.&procedureCode      ( {RANAP-ELEMENTARY-PROCEDURES} ),
    criticality            RANAP-ELEMENTARY-PROCEDURE.&criticality          ( {RANAP-ELEMENTARY-
PROCEDURES}{@procedureCode} ),
    value                  RANAP-ELEMENTARY-PROCEDURE.&SuccessfulOutcome    ( {RANAP-ELEMENTARY-
PROCEDURES}{@procedureCode} )
}

UnsuccessfulOutcome ::= SEQUENCE {
    procedureCode          RANAP-ELEMENTARY-PROCEDURE.&procedureCode      ( {RANAP-ELEMENTARY-PROCEDURES} ),
    criticality            RANAP-ELEMENTARY-PROCEDURE.&criticality          ( {RANAP-ELEMENTARY-
PROCEDURES}{@procedureCode} ),
    value                  RANAP-ELEMENTARY-PROCEDURE.&UnsuccessfulOutcome  ( {RANAP-ELEMENTARY-
PROCEDURES}{@procedureCode} )
}

Outcome ::= SEQUENCE {
    procedureCode          RANAP-ELEMENTARY-PROCEDURE.&procedureCode      ( {RANAP-ELEMENTARY-PROCEDURES} ),
    criticality            RANAP-ELEMENTARY-PROCEDURE.&criticality          ( {RANAP-ELEMENTARY-
PROCEDURES}{@procedureCode} ),
    value                  RANAP-ELEMENTARY-PROCEDURE.&Outcome              ( {RANAP-ELEMENTARY-
PROCEDURES}{@procedureCode} )
}

-- *****
--
-- Interface Elementary Procedure List

```

```

--
-- *****
RANAP-ELEMENTARY-PROCEDURES RANAP-ELEMENTARY-PROCEDURE ::= {
    RANAP-ELEMENTARY-PROCEDURES-CLASS-1 |
    RANAP-ELEMENTARY-PROCEDURES-CLASS-2 |
    RANAP-ELEMENTARY-PROCEDURES-CLASS-3 ,
    ...
}

RANAP-ELEMENTARY-PROCEDURES-CLASS-1 RANAP-ELEMENTARY-PROCEDURE ::= {
    iu-Release |
    relocationPreparation |
    relocationResourceAllocation |
    relocationCancel |
    sRNS-ContextTransfer |
    securityModeControl |
    dataVolumeReport |
    cN-InformationBroadcast |
    reset ,
    ...
}

RANAP-ELEMENTARY-PROCEDURES-CLASS-2 RANAP-ELEMENTARY-PROCEDURE ::= {
    rAB-ReleaseRequest |
    iu-ReleaseRequest |
    relocationDetect |
    relocationComplete |
    paging |
    commonID |
    cN-InvokeTrace |
    locationReportingControl |
    locationReport |
    initialUE-Message |
    directTransfer |
    overloadControl |
    errorIndication |
    sRNS-DataForward |
    forwardSRNS-Context ,
    ...
}

RANAP-ELEMENTARY-PROCEDURES-CLASS-3 RANAP-ELEMENTARY-PROCEDURE ::= {
    rAB-Assignment |
    privateProcedure ,
    ...
}

```

```
}  
  
-- *****  
--  
-- Interface Elementary Procedures  
--  
-- *****  
  
iu-Release RANAP-ELEMENTARY-PROCEDURE ::= {  
    INITIATING MESSAGE      Iu-ReleaseCommand  
    SUCCESSFUL OUTCOME      Iu-ReleaseComplete  
    CODE                     id-Iu-Release  
    CRITICALITY              ignore  
}  
  
relocationPreparation RANAP-ELEMENTARY-PROCEDURE ::= {  
    INITIATING MESSAGE      RelocationRequired  
    SUCCESSFUL OUTCOME      RelocationCommand  
    UNSUCCESSFUL OUTCOME    RelocationPreparationFailure  
    CODE                     id-RelocationPreparation  
    CRITICALITY              ignore  
}  
  
relocationResourceAllocation RANAP-ELEMENTARY-PROCEDURE ::= {  
    INITIATING MESSAGE      RelocationRequest  
    SUCCESSFUL OUTCOME      RelocationRequestAcknowledge  
    UNSUCCESSFUL OUTCOME    RelocationFailure  
    CODE                     id-RelocationResourceAllocation  
    CRITICALITY              ignore  
}  
  
relocationCancel RANAP-ELEMENTARY-PROCEDURE ::= {  
    INITIATING MESSAGE      RelocationCancel  
    SUCCESSFUL OUTCOME      RelocationCancelAcknowledge  
    CODE                     id-RelocationCancel  
    CRITICALITY              ignore  
}  
  
sRNS-ContextTransfer RANAP-ELEMENTARY-PROCEDURE ::= {  
    INITIATING MESSAGE      SRNS-ContextRequest  
    SUCCESSFUL OUTCOME      SRNS-ContextResponse  
    CODE                     id-SRNS-ContextTransfer  
    CRITICALITY              ignore  
}  
  
securityModeControl RANAP-ELEMENTARY-PROCEDURE ::= {  
    INITIATING MESSAGE      SecurityModeCommand
```

```

        SUCCESSFUL OUTCOME      SecurityModeComplete
        UNSUCCESSFUL OUTCOME    SecurityModeReject
        CODE                     id-SecurityModeControl
        CRITICALITY             ignore
    }

dataVolumeReport RANAP-ELEMENTARY-PROCEDURE ::= {
    INITIATING MESSAGE      DataVolumeReportRequest
    SUCCESSFUL OUTCOME      DataVolumeReport
    CODE                     id-DataVolumeReport
    CRITICALITY             ignore
}

cN-InformationBroadcast RANAP-ELEMENTARY-PROCEDURE ::= {
    INITIATING MESSAGE      CN-InformationBroadcastRequest
    SUCCESSFUL OUTCOME      CN-InformationBroadcastConfirm
    UNSUCCESSFUL OUTCOME    CN-InformationBroadcastReject
    CODE                     id-CN-InformationBroadcast
    CRITICALITY             ignore
}

reset RANAP-ELEMENTARY-PROCEDURE ::= {
    INITIATING MESSAGE      Reset
    SUCCESSFUL OUTCOME      ResetAcknowledge
    CODE                     id-Reset
    CRITICALITY             ignore
}

rAB-ReleaseRequest RANAP-ELEMENTARY-PROCEDURE ::= {
    INITIATING MESSAGE      RAB-ReleaseRequest
    CODE                     id-RAB-ReleaseRequest
    CRITICALITY             ignore
}

iu-ReleaseRequest RANAP-ELEMENTARY-PROCEDURE ::= {
    INITIATING MESSAGE      Iu-ReleaseRequest
    CODE                     id-Iu-ReleaseRequest
    CRITICALITY             ignore
}

relocationDetect RANAP-ELEMENTARY-PROCEDURE ::= {
    INITIATING MESSAGE      RelocationDetect
    CODE                     id-RelocationDetect
    CRITICALITY             ignore
}

relocationComplete RANAP-ELEMENTARY-PROCEDURE ::= {

```



```
INITIATING MESSAGE RelocationComplete
CODE id-RelocationComplete
CRITICALITY ignore
}

paging RANAP-ELEMENTARY-PROCEDURE ::= {
INITIATING MESSAGE Paging
CODE id-Paging
CRITICALITY ignore
}

commonID RANAP-ELEMENTARY-PROCEDURE ::= {
INITIATING MESSAGE CommonID
CODE id-CommonID
CRITICALITY ignore
}

cN-InvokeTrace RANAP-ELEMENTARY-PROCEDURE ::= {
INITIATING MESSAGE CN-InvokeTrace
CODE id-CN-InvokeTrace
CRITICALITY ignore
}

locationReportingControl RANAP-ELEMENTARY-PROCEDURE ::= {
INITIATING MESSAGE LocationReportingControl
CODE id-LocationReportingControl
CRITICALITY ignore
}

locationReport RANAP-ELEMENTARY-PROCEDURE ::= {
INITIATING MESSAGE LocationReport
CODE id-LocationReport
CRITICALITY ignore
}

initialUE-Message RANAP-ELEMENTARY-PROCEDURE ::= {
INITIATING MESSAGE InitialUE-Message
CODE id-InitialUE-Message
CRITICALITY ignore
}

directTransfer RANAP-ELEMENTARY-PROCEDURE ::= {
INITIATING MESSAGE DirectTransfer
CODE id-DirectTransfer
CRITICALITY ignore
}
```

```

overloadControl RANAP-ELEMENTARY-PROCEDURE ::= {
    INITIATING MESSAGE      Overload
    CODE                    id-OverloadControl
    CRITICALITY             ignore
}

errorIndication RANAP-ELEMENTARY-PROCEDURE ::= {
    INITIATING MESSAGE      ErrorIndication
    CODE                    id-ErrorIndication
    CRITICALITY             ignore
}

sRNS-DataForward RANAP-ELEMENTARY-PROCEDURE ::= {
    INITIATING MESSAGE      SRNS-DataForwardCommand
    CODE                    id-SRNS-DataForward
    CRITICALITY             ignore
}

forwardSRNS-Context RANAP-ELEMENTARY-PROCEDURE ::= {
    INITIATING MESSAGE      ForwardSRNS-Context
    CODE                    id-ForwardSRNS-Context
    CRITICALITY             ignore
}

rAB-Assignment RANAP-ELEMENTARY-PROCEDURE ::= {
    INITIATING MESSAGE      RAB-AssignmentRequest
    OUTCOME                  RAB-AssignmentResponse
    CODE                    id-RAB-Assignment
    CRITICALITY             ignore
}

privateProcedure RANAP-ELEMENTARY-PROCEDURE ::= {
    INITIATING MESSAGE      PrivateMessage
    OUTCOME                  PrivateMessage
    CODE                    id-Private
    CRITICALITY             ignore
}

END

```

PDU Definitions

```

-- *****
--

```

```
-- PDU definitions for RANAP.
--
-- *****

RANAP-PDU-Contents -- { object identifier to be allocated }--
DEFINITIONS AUTOMATIC TAGS ::=

BEGIN

-- *****
--
-- IE parameter types from other modules.
--
-- *****

IMPORTS

    DataVolumeReference,
    AreaIdentity,
    CN-DomainIndicator,
    CategorisationParameters,
    Cause,
    CriticalityDiagnostics,
    ChosenEncryptionAlgorithm,
    ChosenIntegrityProtectionAlgorithm,
    ChosenUP-Version,
    ClassmarkInformation2,
    ClassmarkInformation3,
    DL-GTP-PDU-SequenceNumber,
    DL-N-PDU-SequenceNumber,
    DataVolumeReportingIndication,
    EncryptionInformation,
    IntegrityProtectionInformation,
    IuTransportAssociation,
    L3-Information,
    LAI,
    NAS-BindingInformation,
    NAS-BroadcastInformation,
    NAS-PDU,
    NonSearchingIndication,
    NumberOfSteps,
    OMC-ID,
    OldBSS-ToNewBSS-Information,
    PagingAreaID,
    PagingCause,
    PermanentNAS-UE-ID,
    RAB-ID,
    RAB-Parameters,
```

RAC,
 RelocationType,
 RequestType,
 SAI,
 SAPI,
 SourceID,
 SourceRNC-ToTargetRNC-TransparentContainer,
 TargetID,
 TargetRNC-ToSourceRNC-TransparentContainer,
 TemporaryUE-ID,
 TraceReference,
 TraceType,
 UnsuccessfullyTransmittedDataVolume,
 TransportLayerAddress,
 TriggerID,
 UE-ID,
 UL-GTP-PDU-SequenceNumber,
 UL-N-PDU-SequenceNumber,
 UP-ModeVersions,
 UserPlaneMode

FROM RANAP-IEs

PrivateExtensionContainer{},
 ProtocolExtensionContainer{},
 ProtocolIE-ContainerList{},
 ProtocolIE-ContainerPair{},
 ProtocolIE-ContainerPairList{},
 ProtocolIE-Container{},
 RANAP-PRIVATE-EXTENSION,
 RANAP-PROTOCOL-EXTENSION,
 RANAP-PROTOCOL-IES,
 RANAP-PROTOCOL-IES-PAIR

FROM RANAP-Containers

maxNrOfErrors,
 maxNrOfPieces,
 maxNrOfRABs,
 maxNrOfVol,

 id-AreaIdentity,
 id-CN-BroadcastInformationPiece,
 id-CN-BroadcastInformationPieceList,
 id-CN-DomainIndicator,
 id-Cause,
 id-ChosenEncryptionAlgorithm,
 id-ChosenIntegrityProtectionAlgorithm,
 id-ClassmarkInformation2,

id-ClassmarkInformation3,
id-CriticalityDiagnostics,
id-DL-GTP-PDU-SequenceNumber,
id-EncryptionInformation,
id-IntegrityProtectionInformation,
id-IuTransportAssociation,
id-L3-Information,
id-LAI,
id-NAS-PDU,
id-NonSearchingIndication,
id-NumberOfSteps,
id-OMC-ID,
id-OldBSS-ToNewBSS-Information,
id-PagingAreaID,
id-PagingCause,
id-PermanentNAS-UE-ID,
id-RAB-ContextItem,
id-RAB-ContextList,
id-RAB-DataForwardingItem,
id-RAB-DataForwardingItem-SRNS-CtxReq,
id-RAB-DataForwardingList,
id-RAB-DataForwardingList-SRNS-CtxReq,
id-RAB-DataVolumeReportItem,
id-RAB-DataVolumeReportList,
id-RAB-DataVolumeReportRequestItem,
id-RAB-DataVolumeReportRequestList,
id-RAB-FailedItem,
id-RAB-FailedList,
id-RAB-ID,
id-RAB-QueuedItem,
id-RAB-QueuedList,
id-RAB-ReleaseFailedList,
id-RAB-ReleaseItem,
id-RAB-ReleaseList,
id-RAB-ReleasedItem,
id-RAB-ReleasedList,
id-RAB-ReleasedList-IuRelComp,
id-RAB-RelocationReleaseItem,
id-RAB-RelocationReleaseList,
id-RAB-SetupItem-RelocReq,
id-RAB-SetupItem-RelocReqAck,
id-RAB-SetupList-RelocReq,
id-RAB-SetupList-RelocReqAck,
id-RAB-SetupOrModifiedItem,
id-RAB-SetupOrModifiedList,
id-RAB-SetupOrModifyItem,
id-RAB-SetupOrModifyList,

```

        id-RAC,
        id-RelocationType,
        id-RequestType,
        id-SAI,
        id-SAPI,
        id-SourceID,
        id-SourceRNC-ToTargetRNC-TransparentContainer,
        id-TargetID,
        id-TargetRNC-ToSourceRNC-TransparentContainer,
        id-TemporaryUE-ID,
        id-TraceReference,
        id-TraceType,
        id-TransportLayerAddress,
        id-TriggerID,
        id-UE-ID,
        id-UL-GTP-PDU-SequenceNumber
FROM RANAP-Constants;

-- *****
--
-- Common Container Lists
--
-- *****

RAB-IE-ContainerList          { RANAP-PROTOCOL-IES      : IEsSetParam }      ::= ProtocolIE-ContainerList    { 1,
maxNrOfRABs, {IEsSetParam} }
RAB-IE-ContainerPairList     { RANAP-PROTOCOL-IES-PAIR : IEsSetParam }      ::= ProtocolIE-ContainerPairList { 1,
maxNrOfRABs, {IEsSetParam} }
ProtocolError-IE-ContainerList { RANAP-PROTOCOL-IES      : IEsSetParam }      ::= ProtocolIE-ContainerList    { 1,
maxNrOfRABs, {IEsSetParam} }
CN-BroadcastInfPiece-IE-ContainerList { RANAP-PROTOCOL-IES : IEsSetParam }      ::= ProtocolIE-ContainerList    { 1,
maxNrOfPieces, {IEsSetParam} }

-- *****
--
-- Iu RELEASE ELEMENTARY PROCEDURE
--
-- *****

-- *****
--
-- Iu Release Command
--
-- *****

Iu-ReleaseCommand ::= SEQUENCE {
    protocolIEs          ProtocolIE-Container          { {Iu-ReleaseCommandIEs} },

```

```

        protocolExtensions          ProtocolExtensionContainer { {Iu-ReleaseCommandExtensions} }
            OPTIONAL,
        ...
    }

Iu-ReleaseCommandIEs RANAP-PROTOCOL-IES ::= {
    { ID id-Cause
        PRESENCE mandatory           },          CRITICALITY ignore          TYPE Cause
        ...
    }

Iu-ReleaseCommandExtensions RANAP-PROTOCOL-EXTENSION ::= {
    ...
}

-- *****
--
-- Iu Release Complete
--
-- *****

Iu-ReleaseComplete ::= SEQUENCE {
    protocolIEs          ProtocolIE-Container      { {Iu-ReleaseCompleteIEs} },
    protocolExtensions   ProtocolExtensionContainer { {Iu-ReleaseCompleteExtensions} }
        OPTIONAL,
    ...
}

Iu-ReleaseCompleteIEs RANAP-PROTOCOL-IES ::= {
    { ID id-RAB-DataVolumeReportList
        PRESENCE conditional
        -- This group is only present if data volume reporting for PS domain is required --
        } |
    { ID id-RAB-ReleasedList-IuRelComp
        PRESENCE conditional
        -- This group is only present for RABs towards the PS domain when the release was initiated by UTRAN --
        } |
    { ID id-CriticalityDiagnostics
        PRESENCE optional           },          CRITICALITY ignore          TYPE CriticalityDiagnostics
        ...
    }

RAB-DataVolumeReportList
DataVolumeReportItemIEs } ::= RAB-IE-ContainerList { {RAB-

RAB-DataVolumeReportItemIEs RANAP-PROTOCOL-IES ::= {

```

```

        { ID id-RAB-DataVolumeReportItem
          PRESENCE mandatory      },
        ...
    }

RAB-DataVolumeReportItem ::= SEQUENCE {
    rAB-ID
    dl-UnsuccessfullyTransmittedDataVolume
    -- This IE is only present if data volume reporting for PS domain is required --,
    iE-Extensions
DataVolumeReportItem-ExtIEs} }
    ...
}

RAB-DataVolumeReportItem-ExtIEs RANAP-PROTOCOL-EXTENSION ::= {
    ...
}

RAB-ReleasedList-IuRelComp
IuRelComp-IEs} } ::= RAB-IE-ContainerList { {RAB-ReleasedItem-

RAB-ReleasedItem-IuRelComp-IEs RANAP-PROTOCOL-IES ::= {
    { ID id-RAB-ID
      PRESENCE mandatory      } |
    { ID id-DL-GTP-PDU-SequenceNumber
      PRESENCE mandatory      } |
    { ID id-UL-GTP-PDU-SequenceNumber
      PRESENCE mandatory      },
    ...
}

Iu-ReleaseCompleteExtensions RANAP-PROTOCOL-EXTENSION ::= {
    ...
}

-- *****
--
-- RELOCATION PREPARATION ELEMENTARY PROCEDURE
--
-- *****

-- *****
--
-- Relocation Required
--
-- *****

```



```

RelocationRequired ::= SEQUENCE {
    protocolIEs                ProtocolIE-Container      { {RelocationRequiredIEs} },
    protocolExtensions         ProtocolExtensionContainer { {RelocationRequiredExtensions} }
        OPTIONAL,
    ...
}

RelocationRequiredIEs RANAP-PROTOCOL-IES ::= {
    { ID id-RelocationType                PRESENCE mandatory          } |          CRITICALITY ignore          TYPE RelocationType
    { ID id-Cause                          PRESENCE mandatory          } |          CRITICALITY ignore          TYPE Cause
    { ID id-SourceID                       PRESENCE mandatory          } |          CRITICALITY ignore          TYPE SourceID
    { ID id-TargetID                       PRESENCE mandatory          } |          CRITICALITY reject          TYPE TargetID
    { ID id-ClassmarkInformation2          PRESENCE conditional        } |          CRITICALITY ignore          TYPE ClassmarkInformation2
    -- This is only present when initiating an inter system handover towards GSM BSC --
    { ID id-ClassmarkInformation3          PRESENCE conditional        } |          CRITICALITY ignore          TYPE ClassmarkInformation3
    -- This is only present when initiating an inter system handover towards GSM BSC --
    { ID id-SourceRNC-ToTargetRNC-TransparentContainer PRESENCE mandatory          } |          CRITICALITY reject          TYPE
SourceRNC-ToTargetRNC-TransparentContainer PRESENCE mandatory } |
    { ID id-OldBSS-ToNewBSS-Information    PRESENCE conditional        } |          CRITICALITY ignore          TYPE OldBSS-ToNewBSS-Information
    -- This is only present when initiating an inter system handover towards GSM BSC --
    ...
}

RelocationRequiredExtensions RANAP-PROTOCOL-EXTENSION ::= {
    ...
}

-- *****
--
-- Relocation Command
--
-- *****

RelocationCommand ::= SEQUENCE {
    protocolIEs                ProtocolIE-Container      { {RelocationCommandIEs} },

```

```

        protocolExtensions                ProtocolExtensionContainer { {RelocationCommandExtensions} }
            OPTIONAL,
        ...
    }

RelocationCommandIEs RANAP-PROTOCOL-IES ::= {
    { ID id-TargetRNC-ToSourceRNC-TransparentContainer
        CRITICALITY reject          TYPE
TargetRNC-ToSourceRNC-TransparentContainer PRESENCE conditional
    -- Must be included if applicable and if not sent via other CN --
    } |
    { ID id-L3-Information
        PRESENCE conditional
        CRITICALITY ignore          TYPE L3-Information
    -- This IE is only present when the source of an inter system handover is GSM BSS --
    } |
    { ID id-RAB-RelocationReleaseList
        PRESENCE optional          CRITICALITY ignore          TYPE RAB-RelocationReleaseList
    } |
    { ID id-RAB-DataForwardingList
        PRESENCE conditional
        CRITICALITY ignore          TYPE RAB-DataForwardingList
    -- This group if applicable is only present for RABs towards the PS domain --
    } |
    { ID id-CriticalityDiagnostics
        PRESENCE optional          CRITICALITY ignore          TYPE CriticalityDiagnostics
    }
    ...
}

RAB-RelocationReleaseList ::= RAB-IE-ContainerList { {RAB-
RelocationReleaseItemIEs} }

RAB-RelocationReleaseItemIEs RANAP-PROTOCOL-IES ::= {
    { ID id-RAB-RelocationReleaseItem
        PRESENCE mandatory          CRITICALITY ignore          TYPE RAB-RelocationReleaseItem
    }
    ...
}

RAB-RelocationReleaseItem ::= SEQUENCE {
    rAB-ID                                RAB-ID,
    iE-Extensions                          ProtocolExtensionContainer { {RAB-
RelocationReleaseItem-ExtIEs} }          OPTIONAL,
    ...
}

RAB-RelocationReleaseItem-ExtIEs RANAP-PROTOCOL-EXTENSION ::= {
    ...
}

```

```

RAB-DataForwardingList                               ::= RAB-IE-ContainerList { {RAB-
DataForwardingItemIEs} }

RAB-DataForwardingItemIEs RANAP-PROTOCOL-IES ::= {
    { ID id-RAB-DataForwardingItem                    CRITICALITY ignore      TYPE RAB-DataForwardingItem
      PRESENCE mandatory                               },
    ...
}

RAB-DataForwardingItem ::= SEQUENCE {
    rAB-ID                                             RAB-ID,
    transportLayerAddress                            TransportLayerAddress,
    iuTransportAssociation                            IuTransportAssociation,
    iE-Extensions                                     ProtocolExtensionContainer { {RAB-
DataForwardingItem-ExtIEs} }                       OPTIONAL,
    ...
}

RAB-DataForwardingItem-ExtIEs RANAP-PROTOCOL-EXTENSION ::= {
    ...
}

RelocationCommandExtensions RANAP-PROTOCOL-EXTENSION ::= {
    ...
}

-- *****
--
-- Relocation Preparation Failure
--
-- *****

RelocationPreparationFailure ::= SEQUENCE {
    protocolIEs                                     ProtocolIE-Container    { {RelocationPreparationFailureIEs} },
    protocolExtensions                             ProtocolExtensionContainer { {RelocationPreparationFailureExtensions} }
    OPTIONAL,
    ...
}

RelocationPreparationFailureIEs RANAP-PROTOCOL-IES ::= {
    { ID id-Cause                                     PRESENCE mandatory     CRITICALITY ignore      TYPE Cause
      PRESENCE optional                               },
    { ID id-CriticalityDiagnostics                   CRITICALITY ignore     TYPE CriticalityDiagnostics
      PRESENCE optional                               },
    ...
}

```

```

RelocationPreparationFailureExtensions RANAP-PROTOCOL-EXTENSION ::= {
    ...
}

-- *****
--
-- RELOCATION RESOURCE ALLOCATION ELEMENTARY PROCEDURE
--
-- *****

-- *****
--
-- Relocation Request
--
-- *****

RelocationRequest ::= SEQUENCE {
    protocolIEs                ProtocolIE-Container    { {RelocationRequestIEs} },
    protocolExtensions         ProtocolExtensionContainer { {RelocationRequestExtensions} }
    OPTIONAL,
    ...
}

RelocationRequestIEs RANAP-PROTOCOL-IES ::= {
    { ID id-PermanentNAS-UE-ID                CRITICALITY ignore      TYPE PermanentNAS-UE-ID
      PRESENCE conditional
      -- This IE is only present if available at the sending side --
    } |
    { ID id-Cause                             CRITICALITY ignore      TYPE Cause
      PRESENCE mandatory
    } |
    { ID id-CN-DomainIndicator                CRITICALITY ignore      TYPE CN-DomainIndicator
      PRESENCE mandatory
    } |
    { ID id-SourceRNC-ToTargetRNC-TransparentContainer
      PRESENCE mandatory
    } |
    { ID id-RAB-SetupList-RelocReq            CRITICALITY ignore      TYPE RAB-SetupList-RelocReq
      PRESENCE mandatory
    } |
    { ID id-IntegrityProtectionInformation    CRITICALITY ignore      TYPE
      PRESENCE mandatory
    } |
    { ID id-EncryptionInformation            CRITICALITY ignore      TYPE EncryptionInformation
      PRESENCE optional
    },
    ...
}

RAB-SetupList-RelocReq
IEs } ::= RAB-IE-ContainerList { {RAB-SetupItem-RelocReq-

```

```

RAB-SetupItem-RelocReq-IEs RANAP-PROTOCOL-IES ::= {
    { ID id-RAB-SetupItem-RelocReq
      PRESENCE mandatory },
    ...
}

RAB-SetupItem-RelocReq ::= SEQUENCE {
    rAB-ID
    NAS-BindingInformation
    rAB-Parameters
    dataVolumeReportingIndication
    -- This IE is only present if available at the sending side --,
    userPlaneInformation
    transportLayerAddress
    iuTransportAssociation
    iE-Extensions
SetupItem-RelocReq-ExtIEs }
    ...
}

RAB-SetupItem-RelocReq-ExtIEs RANAP-PROTOCOL-EXTENSION ::= {
    ...
}

UserPlaneInformation ::= SEQUENCE {
    userPlaneMode
    uP-ModeVersions
    iE-Extensions
{UserPlaneInformation-ExtIEs} }
    ...
}

UserPlaneInformation-ExtIEs RANAP-PROTOCOL-EXTENSION ::= {
    ...
}

RelocationRequestExtensions RANAP-PROTOCOL-EXTENSION ::= {
    ...
}

-- *****
--
-- Relocation Request Acknowledge
--
-- *****

```

```

RelocationRequestAcknowledge ::= SEQUENCE {
    protocolIEs                ProtocolIE-Container      { {RelocationRequestAcknowledgeIEs} },
    protocolExtensions         ProtocolExtensionContainer { {RelocationRequestAcknowledgeExtensions} }
        OPTIONAL,
    ...
}

RelocationRequestAcknowledgeIEs RANAP-PROTOCOL-IES ::= {
    { ID id-TargetRNC-ToSourceRNC-TransparentContainer
        CRITICALITY ignore      TYPE
TargetRNC-ToSourceRNC-TransparentContainer PRESENCE conditional
    -- Must be included if applicapble and if not sent via the other CN --
        } |
    { ID id-RAB-SetupList-RelocReqAck
        PRESENCE conditional
        CRITICALITY ignore      TYPE RAB-SetupList-RelocReqAck
    -- This Group is only present for RABs towards the PS domain --
        } |
    { ID id-RAB-FailedList
        PRESENCE conditional
        CRITICALITY ignore      TYPE RAB-FailedList
    -- This group must be present at least when tno other group is present, i.e. at least one group must be present --
        } |
    { ID id-ChosenIntegrityProtectionAlgorithm
        PRESENCE mandatory
        CRITICALITY ignore      TYPE ChosenIntegrityProtectionAlgorithm
    { ID id-ChosenEncryptionAlgorithm
        PRESENCE optional
        CRITICALITY ignore      TYPE ChosenEncryptionAlgorithm
    { ID id-CriticalityDiagnostics
        PRESENCE optional
        CRITICALITY ignore      TYPE CriticalityDiagnostics
    ...
}

RAB-SetupList-RelocReqAck
RelocReqAck-IEs } ::= RAB-IE-ContainerList { {RAB-SetupItem-

RAB-SetupItem-RelocReqAck-IEs RANAP-PROTOCOL-IES ::= {
    { ID id-RAB-SetupItem-RelocReqAck
        PRESENCE mandatory
        CRITICALITY reject      TYPE RAB-SetupItem-RelocReqAck
    ...
}

RAB-SetupItem-RelocReqAck ::= SEQUENCE {
    rAB-ID
        RAB-ID,
    chosenUP-Version
        ChosenUP-Version
        OPTIONAL,
    transportLayerAddress
        TransportLayerAddress,
    iuTransportAssociation
        IuTransportAssociation,
    iE-Extensions
        ProtocolExtensionContainer { {RAB-
SetupItem-RelocReqAck-ExtIEs} }
        OPTIONAL,
    ...
}

```

```

}

RAB-SetupItem-RelocReqAck-ExtIEs RANAP-PROTOCOL-EXTENSION ::= {
    ...
}

RAB-FailedList ::= RAB-IE-ContainerList { {RAB-
FailedItemIEs} }

RAB-FailedItemIEs RANAP-PROTOCOL-IES ::= {
    { ID id-RAB-FailedItem                                CRITICALITY ignore          TYPE RAB-FailedItem
    PRESENCE mandatory } ,
    ...
}

RAB-FailedItem ::= SEQUENCE {
    rAB-ID                                RAB-ID,
    cause                                  Cause,
    iE-Extensions                          ProtocolExtensionContainer { {RAB-
FailedItem-ExtIEs} }                      OPTIONAL,
    ...
}

RAB-FailedItem-ExtIEs RANAP-PROTOCOL-EXTENSION ::= {
    ...
}

RelocationRequestAcknowledgeExtensions RANAP-PROTOCOL-EXTENSION ::= {
    ...
}

-- *****
--
-- Relocation Failure
--
-- *****

RelocationFailure ::= SEQUENCE {
    protocolIEs                                ProtocolIE-Container    { {RelocationFailureIEs} },
    protocolExtensions                          ProtocolExtensionContainer { {RelocationFailureExtensions} }
    OPTIONAL,
    ...
}

RelocationFailureIEs RANAP-PROTOCOL-IES ::= {
    { ID id-Cause                                CRITICALITY ignore          TYPE Cause
    PRESENCE mandatory } |

```

```

        { ID id-CriticalityDiagnostics
          PRESENCE optional },
        ...
    }

```

```

RelocationFailureExtensions RANAP-PROTOCOL-EXTENSION ::= {
    ...
}

```

```

-- *****
--
-- RELOCATION CANCEL ELEMENTARY PROCEDURE
--
-- *****
--
-- *****
--
-- Relocation Cancel
--
-- *****

```

```

RelocationCancel ::= SEQUENCE {
    protocolIEs          ProtocolIE-Container    { {RelocationCancelIEs} },
    protocolExtensions  ProtocolExtensionContainer { {RelocationCancelExtensions} }
    OPTIONAL,
    ...
}

```

```

RelocationCancelIEs RANAP-PROTOCOL-IES ::= {
    { ID id-Cause
      PRESENCE mandatory },
    ...
}

```

```

RelocationCancelExtensions RANAP-PROTOCOL-EXTENSION ::= {
    ...
}

```

```

-- *****
--
-- Relocation Cancel Acknowledge
--
-- *****

```

```

RelocationCancelAcknowledge ::= SEQUENCE {
    protocolIEs          ProtocolIE-Container    { {RelocationCancelAcknowledgeIEs} },

```



```

        protocolExtensions          ProtocolExtensionContainer { {RelocationCancelAcknowledgeExtensions} }
            OPTIONAL,
        ...
    }

RelocationCancelAcknowledgeIEs RANAP-PROTOCOL-IES ::= {
    { ID id-CriticalityDiagnostics          CRITICALITY ignore          TYPE CriticalityDiagnostics
      PRESENCE optional                    },
    ...
}

RelocationCancelAcknowledgeExtensions RANAP-PROTOCOL-EXTENSION ::= {
    ...
}

-- *****
--
-- SRNS CONTEXT TRANSFER OPEARATION
--
-- *****

-- *****
--
-- SRNS Context Request
--
-- *****

SRNS-ContextRequest ::= SEQUENCE {
    protocolIEs          ProtocolIE-Container      { {SRNS-ContextRequestIEs} },
    protocolExtensions  ProtocolExtensionContainer { {SRNS-ContextRequestExtensions} }
            OPTIONAL,
    ...
}

SRNS-ContextRequestIEs RANAP-PROTOCOL-IES ::= {
    { ID id-RAB-DataForwardingList-SRNS-CtxReq          CRITICALITY ignore          TYPE RAB-DataForwardingList-SRNS-CtxReq
      PRESENCE mandatory                                },
    ...
}

RAB-DataForwardingList-SRNS-CtxReq ::= RAB-IE-ContainerList { {RAB-DataForwardingItem-SRNS-CtxReq-
IEs} }

RAB-DataForwardingItem-SRNS-CtxReq-IEs RANAP-PROTOCOL-IES ::= {
    { ID id-RAB-DataForwardingItem-SRNS-CtxReq          CRITICALITY ignore          TYPE RAB-DataForwardingItem-SRNS-CtxReq
      PRESENCE mandatory                                },
    ...
}

```

```

}

RAB-DataForwardingItem-SRNS-CtxReq ::= SEQUENCE {
    rAB-ID                                RAB-ID,
    iE-Extensions                          ProtocolExtensionContainer { {RAB-
DataForwardingItem-SRNS-CtxReq-ExtIEs} } OPTIONAL,
    ...
}

RAB-DataForwardingItem-SRNS-CtxReq-ExtIEs RANAP-PROTOCOL-EXTENSION ::= {
    ...
}

SRNS-ContextRequestExtensions RANAP-PROTOCOL-EXTENSION ::= {
    ...
}

-- *****
--
-- SRNS Context Response
--
-- *****

SRNS-ContextResponse ::= SEQUENCE {
    protocolIEs                          ProtocolIE-Container    { {SRNS-ContextResponseIEs} },
    protocolExtensions                    ProtocolExtensionContainer { {SRNS-ContextResponseExtensions} }
    ...
    OPTIONAL,
}

SRNS-ContextResponseIEs RANAP-PROTOCOL-IES ::= {
    { ID id-Cause                                PRESENCE mandatory          } |
    { ID id-RAB-ContextList                      PRESENCE mandatory          } |
    { ID id-CriticalityDiagnostics              PRESENCE optional          },
    ...
}

RAB-ContextList ::= RAB-IE-ContainerList { {RAB-ContextItemIEs} }

RAB-ContextItemIEs RANAP-PROTOCOL-IES ::= {
    { ID id-RAB-ContextItem                      PRESENCE mandatory          },
    ...
}

```

```

RAB-ContextItem ::= SEQUENCE {
    rAB-ID
    dl-GTP-PDU-SequenceNumber
    ul-GTP-PDU-SequenceNumber
    dl-N-PDU-SequenceNumber
    ul-N-PDU-SequenceNumber
    iE-Extensions
ContextItem-ExtIEs} }
    OPTIONAL,
    ...
}

RAB-ContextItem-ExtIEs RANAP-PROTOCOL-EXTENSION ::= {
    ...
}

SRNS-ContextResponseExtensions RANAP-PROTOCOL-EXTENSION ::= {
    ...
}

-- *****
--
-- SECURITY MODE CONTROL ELEMENTARY PROCEDURE
--
-- *****

-- *****
--
-- Security Mode Command
--
-- *****

SecurityModeCommand ::= SEQUENCE {
    protocolIEs
    protocolExtensions
    ProtocolIE-Container
    ProtocolExtensionContainer
    { {SecurityModeCommandIEs} },
    { {SecurityModeCommandExtensions} }
    OPTIONAL,
    ...
}

SecurityModeCommandIEs RANAP-PROTOCOL-IES ::= {
    { ID id-IntegrityProtectionInformation
IntegrityProtectionInformation
    { ID id-EncryptionInformation
    PRESENCE mandatory
    PRESENCE optional
    CRITICALITY ignore
    CRITICALITY ignore
    TYPE
    TYPE EncryptionInformation
    } |
    }
    ...
}
    
```

```
SecurityModeCommandExtensions RANAP-PROTOCOL-EXTENSION ::= {
    ...
}
```

```
-- *****
--
-- Security Mode Complete
--
-- *****
```

```
SecurityModeComplete ::= SEQUENCE {
    protocolIEs                ProtocolIE-Container    { {SecurityModeCompleteIEs} },
    protocolExtensions          ProtocolExtensionContainer { {SecurityModeCompleteExtensions} }
    OPTIONAL,
    ...
}
```

```
SecurityModeCompleteIEs RANAP-PROTOCOL-IES ::= {
    { ID id-ChosenIntegrityProtectionAlgorithm    CRITICALITY ignore    TYPE ChosenIntegrityProtectionAlgorithm
    PRESENCE mandatory    } |
    { ID id-ChosenEncryptionAlgorithm            CRITICALITY ignore    TYPE ChosenEncryptionAlgorithm
    PRESENCE optional      } |
    { ID id-CriticalityDiagnostics                CRITICALITY ignore    TYPE CriticalityDiagnostics
    PRESENCE optional      },
    ...
}
```

```
SecurityModeCompleteExtensions RANAP-PROTOCOL-EXTENSION ::= {
    ...
}
```

```
-- *****
--
-- Security Mode Reject
--
-- *****
```

```
SecurityModeReject ::= SEQUENCE {
    protocolIEs                ProtocolIE-Container    { {SecurityModeRejectIEs} },
    protocolExtensions          ProtocolExtensionContainer { {SecurityModeRejectExtensions} }
    OPTIONAL,
    ...
}
```

```
SecurityModeRejectIEs RANAP-PROTOCOL-IES ::= {
    { ID id-Cause                CRITICALITY ignore    TYPE Cause
    PRESENCE mandatory    } |
```

```

        { ID id-CriticalityDiagnostics
          PRESENCE optional },
        ...
    }

SecurityModeRejectExtensions RANAP-PROTOCOL-EXTENSION ::= {
    ...
}

-- *****
--
-- DATA VOLUME REPORT ELEMENTARY PROCEDURE
--
-- *****

-- *****
--
-- Data Volume Report Request
--
-- *****

DataVolumeReportRequest ::= SEQUENCE {
    protocolIEs          ProtocolIE-Container    { {DataVolumeReportRequestIEs} },
    protocolExtensions  ProtocolExtensionContainer { {DataVolumeReportRequestExtensions} }
    OPTIONAL,
    ...
}

DataVolumeReportRequestIEs RANAP-PROTOCOL-IES ::= {
    { ID id-RAB-DataVolumeReportRequestList
      DataVolumeReportRequestList
      PRESENCE mandatory
      CRITICALITY ignore
      TYPE RAB-
    },
    ...
}

RAB-DataVolumeReportRequestList ::= RAB-IE-ContainerList { {RAB-DataVolumeReportRequestItemIEs}
}

RAB-DataVolumeReportRequestItemIEs RANAP-PROTOCOL-IES ::= {
    { ID id-RAB-DataVolumeReportRequestItem
      DataVolumeReportRequestItem
      PRESENCE mandatory
      CRITICALITY ignore
      TYPE RAB-
    },
    ...
}

RAB-DataVolumeReportRequestItem ::= SEQUENCE {
    rAB-ID                RAB-ID,
    iE-Extensions        ProtocolExtensionContainer { {RAB-
    DataVolumeReportRequestItem-ExtIEs} }
    OPTIONAL,

```

```

    ...
}

RAB-DataVolumeReportRequestItem-ExtIEs RANAP-PROTOCOL-EXTENSION ::= {
    ...
}

DataVolumeReportRequestExtensions RANAP-PROTOCOL-EXTENSION ::= {
    ...
}

-- *****
--
-- Data Volume Report
--
-- *****

DataVolumeReport ::= SEQUENCE {
    protocolIEs                ProtocolIE-Container      { {DataVolumeReportIEs} },
    protocolExtensions          ProtocolExtensionContainer { {DataVolumeReportExtensions} }
    OPTIONAL,
    ...
}

DataVolumeReportIEs RANAP-PROTOCOL-IES ::= {
    { ID id-RAB-DataVolumeReportList                CRITICALITY ignore      TYPE RAB-DataVolumeReportList
      PRESENCE mandatory                            } |
    { ID id-CriticalityDiagnostics                  CRITICALITY ignore      TYPE CriticalityDiagnostics
      PRESENCE optional                              },
    ...
}

DataVolumeReportExtensions RANAP-PROTOCOL-EXTENSION ::= {
    ...
}

-- *****
--
-- CN INFORMATION BROADCAST
--
-- *****

-- *****
--
-- CN Information Broadcast Request
--
-- *****

```

```

CN-InformationBroadcastRequest ::= SEQUENCE {
    protocolIEs                ProtocolIE-Container      { {CN-InformationBroadcastRequestIEs} },
    protocolExtensions         ProtocolExtensionContainer { {CN-InformationBroadcastRequestExtensions} }
    OPTIONAL,
    ...
}

CN-InformationBroadcastRequestIEs RANAP-PROTOCOL-IES ::= {
    { ID id-CN-DomainIndicator                CRITICALITY ignore          TYPE CN-DomainIndicator
      PRESENCE mandatory                      } |
    { ID id-CN-BroadcastInformationPieceList  CRITICALITY ignore          TYPE CN-BroadcastInformationPieceList
      PRESENCE mandatory                      },
    ...
}

CN-BroadcastInformationPieceList BroadcastInformationPieceIEs } ::= CN-BroadcastInfPiece-IE-ContainerList { {CN-

CN-BroadcastInformationPieceIEs RANAP-PROTOCOL-IES ::= {
    { ID id-CN-BroadcastInformationPiece      CRITICALITY ignore          TYPE CN-BroadcastInformationPiece
      PRESENCE mandatory                      },
    ...
}

CN-BroadcastInformationPiece ::= SEQUENCE {
    nAS-BroadcastInformation                NAS-BroadcastInformation,
    areaIdentity                            AreaIdentity,
    categorisationParameters                CategorisationParameters,
    iE-Extensions                           ProtocolExtensionContainer { {CN-
BroadcastInformationPiece-ExtIEs} }        OPTIONAL,
    ...
}

CN-BroadcastInformationPiece-ExtIEs RANAP-PROTOCOL-EXTENSION ::= {
    ...
}

CN-InformationBroadcastRequestExtensions RANAP-PROTOCOL-EXTENSION ::= {
    ...
}

-- *****
--
-- CN Information Broadcast Confirm
--
-- *****

```

```

CN-InformationBroadcastConfirm ::= SEQUENCE {
    protocolIEs          ProtocolIE-Container      { {CN-InformationBroadcastConfirmIEs} },
    protocolExtensions   ProtocolExtensionContainer { {CN-InformationBroadcastConfirmExtensions} }
    OPTIONAL,
    ...
}

CN-InformationBroadcastConfirmIEs RANAP-PROTOCOL-IES ::= {
    { ID id-CN-DomainIndicator          PRESENCE mandatory      } |          CRITICALITY ignore          TYPE CN-DomainIndicator
    { ID id-CriticalityDiagnostics      PRESENCE optional      },          CRITICALITY ignore          TYPE CriticalityDiagnostics
    ...
}

CN-InformationBroadcastConfirmExtensions RANAP-PROTOCOL-EXTENSION ::= {
    ...
}

-- *****
--
-- CN Information Broadcast Reject
--
-- *****

CN-InformationBroadcastReject ::= SEQUENCE {
    protocolIEs          ProtocolIE-Container      { {CN-InformationBroadcastRejectIEs} },
    protocolExtensions   ProtocolExtensionContainer { {CN-InformationBroadcastRejectExtensions} }
    OPTIONAL,
    ...
}

CN-InformationBroadcastRejectIEs RANAP-PROTOCOL-IES ::= {
    { ID id-CN-DomainIndicator          PRESENCE mandatory      } |          CRITICALITY ignore          TYPE CN-DomainIndicator
    { ID id-Cause                      PRESENCE mandatory      } |          CRITICALITY ignore          TYPE Cause
    { ID id-CriticalityDiagnostics      PRESENCE optional      },          CRITICALITY ignore          TYPE CriticalityDiagnostics
    ...
}

CN-InformationBroadcastRejectExtensions RANAP-PROTOCOL-EXTENSION ::= {
    ...
}

```



```

-- *****
--
-- RESET ELEMENTARY PROCEDURE
--
-- *****

-- *****
--
-- Reset
--
-- *****

Reset ::= SEQUENCE {
    protocolIEs                ProtocolIE-Container    { {ResetIEs} },
    protocolExtensions          ProtocolExtensionContainer { {ResetExtensions} }
        OPTIONAL,
    ...
}

ResetIEs RANAP-PROTOCOL-IES ::= {
    { ID id-Cause
        PRESENCE mandatory          CRITICALITY ignore          TYPE Cause
    } |
    { ID id-CN-DomainIndicator
        PRESENCE mandatory          CRITICALITY ignore          TYPE CN-DomainIndicator
    },
    ...
}

ResetExtensions RANAP-PROTOCOL-EXTENSION ::= {
    ...
}

-- *****
--
-- Reset Acknowledge
--
-- *****

ResetAcknowledge ::= SEQUENCE {
    protocolIEs                ProtocolIE-Container    { {ResetAcknowledgeIEs} },
    protocolExtensions          ProtocolExtensionContainer { {ResetAcknowledgeExtensions} }
        OPTIONAL,
    ...
}

ResetAcknowledgeIEs RANAP-PROTOCOL-IES ::= {
    { ID id-CN-DomainIndicator
        PRESENCE mandatory          CRITICALITY ignore          TYPE CN-DomainIndicator
    } |

```

```

        { ID id-CriticalityDiagnostics
          PRESENCE optional },
        ...
    }

ResetAcknowledgeExtensions RANAP-PROTOCOL-EXTENSION ::= {
    ...
}

-- *****
--
-- RAB RELEASE REQUEST ELEMENTARY PROCEDURE
--
-- *****

-- *****
--
-- RAB Release Request
--
-- *****

RAB-ReleaseRequest ::= SEQUENCE {
    protocolIEs          ProtocolIE-Container    { {RAB-ReleaseRequestIEs} },
    protocolExtensions  ProtocolExtensionContainer { {RAB-ReleaseRequestExtensions} }
    OPTIONAL,
    ...
}

RAB-ReleaseRequestIEs RANAP-PROTOCOL-IES ::= {
    { ID id-RAB-ReleaseList
      PRESENCE mandatory },
    ...
}

RAB-ReleaseList ::= RAB-IE-ContainerList { {RAB-ReleaseItemIEs} }

RAB-ReleaseItemIEs RANAP-PROTOCOL-IES ::= {
    { ID id-RAB-ReleaseItem
      PRESENCE mandatory },
    ...
}

RAB-ReleaseItem ::= SEQUENCE {
    rAB-ID                RAB-ID,
    cause                 Cause,
    iE-Extensions         ProtocolExtensionContainer { {RAB-
ReleaseItem-ExtIEs} }
    OPTIONAL,

```

```

    ...
}

RAB-ReleaseItem-ExtIEs RANAP-PROTOCOL-EXTENSION ::= {
    ...
}

RAB-ReleaseRequestExtensions RANAP-PROTOCOL-EXTENSION ::= {
    ...
}

-- *****
--
-- Iu RELEASE REQUEST ELEMENTARY PROCEDURE
--
-- *****

-- *****
--
-- Iu Release Request
--
-- *****

Iu-ReleaseRequest ::= SEQUENCE {
    protocolIEs                ProtocolIE-Container    { {Iu-ReleaseRequestIEs} },
    protocolExtensions          ProtocolExtensionContainer { {Iu-ReleaseRequestExtensions} }
    OPTIONAL,
    ...
}

Iu-ReleaseRequestIEs RANAP-PROTOCOL-IES ::= {
    { ID id-Cause
    PRESENCE mandatory          },          CRITICALITY ignore          TYPE Cause
    ...
}

Iu-ReleaseRequestExtensions RANAP-PROTOCOL-EXTENSION ::= {
    ...
}

-- *****
--
-- RELOCATION DETECT ELEMENTARY PROCEDURE
--
-- *****
-- *****

```

```

--
-- Relocation Detect
--
-- *****

RelocationDetect ::= SEQUENCE {
    protocolIEs                ProtocolIE-Container    { {RelocationDetectIEs} },
    protocolExtensions          ProtocolExtensionContainer { {RelocationDetectExtensions} }
        OPTIONAL,
    ...
}

RelocationDetectIEs RANAP-PROTOCOL-IES ::= {
    ...
}

RelocationDetectExtensions RANAP-PROTOCOL-EXTENSION ::= {
    ...
}

-- *****
--
-- RELOCATION COMPLETE ELEMENTARY PROCEDURE
--
-- *****

-- *****
--
-- Relocation Complete
--
-- *****

RelocationComplete ::= SEQUENCE {
    protocolIEs                ProtocolIE-Container    { {RelocationCompleteIEs} },
    protocolExtensions          ProtocolExtensionContainer { {RelocationCompleteExtensions} }
        OPTIONAL,
    ...
}

RelocationCompleteIEs RANAP-PROTOCOL-IES ::= {
    ...
}

RelocationCompleteExtensions RANAP-PROTOCOL-EXTENSION ::= {
    ...
}

```

```

-- *****
--
-- PAGING ELEMENTARY PROCEDURE
--
-- *****

```

```

-- *****
--
-- Paging
--
-- *****

```

```

Paging ::= SEQUENCE {
    protocolIEs                ProtocolIE-Container    { {PagingIEs} },
    protocolExtensions          ProtocolExtensionContainer { {PagingExtensions} }
        OPTIONAL,
    ...
}

```

```

PagingIEs RANAP-PROTOCOL-IES ::= {
    { ID id-CN-DomainIndicator          PRESENCE mandatory   } | CRITICALITY ignore    TYPE CN-DomainIndicator
    { ID id-PermanentNAS-UE-ID         PRESENCE mandatory   } | CRITICALITY ignore    TYPE PermanentNAS-UE-ID
    { ID id-TemporaryUE-ID             PRESENCE optional    } | CRITICALITY ignore    TYPE TemporaryUE-ID
    { ID id-PagingAreaID               PRESENCE optional    } | CRITICALITY ignore    TYPE PagingAreaID
    { ID id-PagingCause                PRESENCE optional    } | CRITICALITY ignore    TYPE PagingCause
    { ID id-NonSearchingIndication      PRESENCE optional    } | CRITICALITY ignore    TYPE NonSearchingIndication
    ...
}

```

```

PagingExtensions RANAP-PROTOCOL-EXTENSION ::= {
    ...
}

```

```

-- *****
--
-- COMMON ID ELEMENTARY PROCEDURE
--
-- *****
--
-- *****

```

```

-- Common ID
--
-- *****

CommonID ::= SEQUENCE {
    protocolIEs          ProtocolIE-Container      { {CommonID-IEs} },
    protocolExtensions   ProtocolExtensionContainer { {CommonIDExtensions} }
        OPTIONAL,
    ...
}

CommonID-IEs RANAP-PROTOCOL-IES ::= {
    { ID id-PermanentNAS-UE-ID          PRESENCE mandatory      },          CRITICALITY ignore          TYPE PermanentNAS-UE-ID
    ...
}

CommonIDExtensions RANAP-PROTOCOL-EXTENSION ::= {
    ...
}

-- *****
--
-- CN INVOKE TRACE ELEMENTARY PROCEDURE
--
-- *****

-- *****
--
-- CN Invoke Trace
--
-- *****

CN-InvokeTrace ::= SEQUENCE {
    protocolIEs          ProtocolIE-Container      { {CN-InvokeTraceIEs} },
    protocolExtensions   ProtocolExtensionContainer { {CN-InvokeTraceExtensions} }
        OPTIONAL,
    ...
}

CN-InvokeTraceIEs RANAP-PROTOCOL-IES ::= {
    { ID id-TraceType          PRESENCE mandatory      },          CRITICALITY ignore          TYPE TraceType
    { ID id-TraceReference     PRESENCE mandatory      } |          CRITICALITY ignore          TYPE TraceReference
    { ID id-TriggerID          PRESENCE optional       },          CRITICALITY ignore          TYPE TriggerID
}

```

```

        { ID id-UE-ID
                                     PRESENCE optional      } |
        { ID id-OMC-ID
                                     PRESENCE optional      },
        ...
    }

```

```

CN-InvokeTraceExtensions RANAP-PROTOCOL-EXTENSION ::= {
    ...
}

```

```

-- *****
--
-- LOCATION REPORTING CONTROL ELEMENTARY PROCEDURE
--
-- *****

-- *****
--
-- Location Reporting Control
--
-- *****

```

```

LocationReportingControl ::= SEQUENCE {
    protocolIEs          ProtocolIE-Container      { {LocationReportingControlIEs} },
    protocolExtensions   ProtocolExtensionContainer { {LocationReportingControlExtensions} }
    OPTIONAL,
    ...
}

```

```

LocationReportingControlIEs RANAP-PROTOCOL-IES ::= {
    { ID id-RequestType
                                     PRESENCE mandatory      },
    ...
}

```

```

LocationReportingControlExtensions RANAP-PROTOCOL-EXTENSION ::= {
    ...
}

```

```

-- *****
--
-- LOCATION REPORT ELEMENTARY PROCEDURE
--
-- *****

-- *****

```

```

--
-- Location Report
--
-- *****

LocationReport ::= SEQUENCE {
    protocolIEs                ProtocolIE-Container      { {LocationReportIEs} },
    protocolExtensions         ProtocolExtensionContainer { {LocationReportExtensions} }
        OPTIONAL,
    ...
}

LocationReportIEs RANAP-PROTOCOL-IES ::= {
    { ID id-AreaIdentity          PRESENCE optional          } |          CRITICALITY ignore          TYPE AreaIdentity
    { ID id-Cause                 PRESENCE optional          } |          CRITICALITY ignore          TYPE Cause
    ...
}

LocationReportExtensions RANAP-PROTOCOL-EXTENSION ::= {
    ...
}

-- *****
--
-- INITIAL UE MESSAGE ELEMENTARY PROCEDURE
--
-- *****

-- *****
--
-- Initial UE Message
--
-- *****

InitialUE-Message ::= SEQUENCE {
    protocolIEs                ProtocolIE-Container      { {InitialUE-MessageIEs} },
    protocolExtensions         ProtocolExtensionContainer { {InitialUE-MessageExtensions} }
        OPTIONAL,
    ...
}

InitialUE-MessageIEs RANAP-PROTOCOL-IES ::= {
    { ID id-CN-DomainIndicator    PRESENCE mandatory          } |          CRITICALITY ignore          TYPE CN-DomainIndicator
}

```



```

{ ID id-LAI
    PRESENCE mandatory } | CRITICALITY ignore TYPE LAI
{ ID id-RAC
    PRESENCE conditional } | CRITICALITY ignore TYPE RAC
-- This IE is only present for RABs towards the PS domain --
{ ID id-SAI
    PRESENCE mandatory } | CRITICALITY ignore TYPE SAI
{ ID id-NAS-PDU
    PRESENCE mandatory }, CRITICALITY ignore TYPE NAS-PDU
...
}

```

```

InitialUE-MessageExtensions RANAP-PROTOCOL-EXTENSION ::= {
    ...
}

```

```

-- *****
--
-- DIRECT TRANSFER ELEMENTARY PROCEDURE
--
-- *****
--
-- *****
--
-- Direct Transfer
--
-- *****

```

```

DirectTransfer ::= SEQUENCE {
    protocolIEs ProtocolIE-Container { {DirectTransferIEs} },
    protocolExtensions ProtocolExtensionContainer { {DirectTransferExtensions} }
    OPTIONAL,
    ...
}

```

```

DirectTransferIEs RANAP-PROTOCOL-IES ::= {
    { ID id-NAS-PDU
        PRESENCE mandatory } | CRITICALITY ignore TYPE NAS-PDU
    { ID id-LAI
        PRESENCE conditional } | CRITICALITY ignore TYPE LAI
    -- This IE is only present if the message is directed to the PS domain --
    { ID id-RAC
        PRESENCE conditional } | CRITICALITY ignore TYPE RAC
    -- This IE is only present if the message is directed to the PS domain --
} |

```

```

        { ID id-SAPI
                PRESENCE conditional
        -- This IE is always used in downlink direction--
        },
        ...
    }

DirectTransferExtensions RANAP-PROTOCOL-EXTENSION ::= {
    ...
}

-- *****
--
-- OVERLOAD CONTROL ELEMENTARY PROCEDURE
--
-- *****

-- *****
--
-- Overload
--
-- *****

Overload ::= SEQUENCE {
    protocolIEs                ProtocolIE-Container    { {OverloadIEs} },
    protocolExtensions          ProtocolExtensionContainer { {OverloadExtensions} }
    OPTIONAL,
    ...
}

OverloadIEs RANAP-PROTOCOL-IES ::= {
    { ID id-NumberOfSteps
            PRESENCE optional    },
    ...
}

OverloadExtensions RANAP-PROTOCOL-EXTENSION ::= {
    ...
}

-- *****
--
-- ERROR INDICATION ELEMENTARY PROCEDURE
--
-- *****

```

```

--
-- Error Indication
--
-- *****

ErrorIndication ::= SEQUENCE {
    protocolIEs                ProtocolIE-Container    { {ErrorIndicationIEs} },
    protocolExtensions         ProtocolExtensionContainer { {ErrorIndicationExtensions} }
        OPTIONAL,
    ...
}

ErrorIndicationIEs RANAP-PROTOCOL-IES ::= {
    { ID id-Cause                PRESENCE conditional                CRITICALITY ignore        TYPE Cause
        -- At least either of Cause IE or Criticality IE shall be present --
    } |
    { ID id-CriticalityDiagnostics PRESENCE conditional                CRITICALITY ignore        TYPE CriticalityDiagnostics
        -- At least either of Cause IE or Criticality IE shall be present --
    } |
    { ID id-CN-DomainIndicator    PRESENCE optional                CRITICALITY ignore        TYPE CN-DomainIndicator
    } |
    { ID id-IuTransportAssociation PRESENCE optional                CRITICALITY ignore        TYPE IuTransportAssociation
    } |
    { ID id-TransportLayerAddress PRESENCE optional                CRITICALITY ignore        TYPE TransportLayerAddress
    },
    ...
}

ErrorIndicationExtensions RANAP-PROTOCOL-EXTENSION ::= {
    ...
}

-- *****
--
-- SRNS DATA FORWARD ELEMENTARY PROCEDURE
--
-- *****

-- *****
--
-- SRNS Data Forward Command
--
-- *****

SRNS-DataForwardCommand ::= SEQUENCE {

```

```

        protocolIEs                ProtocolIE-Container      { {SRNS-DataForwardCommandIEs} },
        protocolExtensions          ProtocolExtensionContainer { {SRNS-DataForwardCommandExtensions} }
        OPTIONAL,
        ...
    }

SRNS-DataForwardCommandIEs RANAP-PROTOCOL-IES ::= {
    { ID id-RAB-DataForwardingList                CRITICALITY ignore          TYPE RAB-DataForwardingList
      PRESENCE conditional
      -- This group is only present for RABs towards the PS domain --
    },
    ...
}

SRNS-DataForwardCommandExtensions RANAP-PROTOCOL-EXTENSION ::= {
    ...
}

-- *****
--
-- FORWARD SRNS CONTEXT ELEMENTARY PROCEDURE
--
-- *****

-- *****
--
-- Forward SRNS Context
--
-- *****

ForwardSRNS-Context ::= SEQUENCE {
    protocolIEs                ProtocolIE-Container      { {ForwardSRNS-ContextIEs} },
    protocolExtensions          ProtocolExtensionContainer { {ForwardSRNS-ContextExtensions} }
    OPTIONAL,
    ...
}

ForwardSRNS-ContextIEs RANAP-PROTOCOL-IES ::= {
    { ID id-RAB-ContextList                CRITICALITY ignore          TYPE RAB-ContextList
      PRESENCE mandatory
    },
    ...
}

ForwardSRNS-ContextExtensions RANAP-PROTOCOL-EXTENSION ::= {
    ...
}

```

```

-- *****
--
-- RAB ASSIGNMENT ELEMENTARY PROCEDURE
--
-- *****

-- *****
--
-- RAB Assignment Request
--
-- *****

RAB-AssignmentRequest ::= SEQUENCE {
    protocolIEs                ProtocolIE-Container    { {RAB-AssignmentRequestIEs} },
    protocolExtensions          ProtocolExtensionContainer { {RAB-AssignmentRequestExtensions} }
        OPTIONAL,
    ...
}

RAB-AssignmentRequestIEs RANAP-PROTOCOL-IES ::= {
    { ID id-RAB-SetupOrModifyList                CRITICALITY ignore        TYPE RAB-SetupOrModifyList
        PRESENCE conditional
        -- This group must be present at least when no other group is present, ie. at least one group must be present --
        } |
    { ID id-RAB-ReleaseList                      CRITICALITY ignore        TYPE RAB-ReleaseList
        PRESENCE conditional
        -- This group must be present at least when no other group is present, ie. at least one group must be present --
        },
    ...
}

RAB-SetupOrModifyList ::= RAB-IE-ContainerPairList { {RAB-
SetupOrModifyItem-IEs} }

RAB-SetupOrModifyItem-IEs RANAP-PROTOCOL-IES-PAIR ::= {
    { ID id-RAB-SetupOrModifyItem                FIRST CRITICALITY reject        FIRST TYPE
RAB-SetupOrModifyItemFirst
        SECOND CRITICALITY ignore
        SECOND TYPE RAB-SetupOrModifyItemSecond
        PRESENCE mandatory        },
    ...
}

RAB-SetupOrModifyItemFirst ::= SEQUENCE {
    rAB-ID                RAB-ID,
    rAB-Parameters        RAB-Parameters,

```

```

        userPlaneInformation          UserPlaneInformation,
        transportLayerAddress         TransportLayerAddress,
        iuTransportAssociation        IuTransportAssociation,
        iE-Extensions                 ProtocolExtensionContainer { {RAB-
SetupOrModifyItemFirst-ExtIEs} }      OPTIONAL,
        ...
    }

RAB-SetupOrModifyItemFirst-ExtIEs RANAP-PROTOCOL-EXTENSION ::= {
    ...
}

RAB-SetupOrModifyItemSecond ::= SEQUENCE {
    nAS-BindingInformation            NAS-BindingInformation,
    dataVolumeReportingIndication    DataVolumeReportingIndication    OPTIONAL
    -- This IE, if applicable, is only present for RABs towards the PS domain --,
    dl-GTP-PDU-SequenceNumber        DL-GTP-PDU-SequenceNumber        OPTIONAL
    -- This IE, if applicable, is only present for RABs towards the PS domain --,
    ul-GTP-PDU-SequenceNumber        UL-GTP-PDU-SequenceNumber        OPTIONAL
    -- This IE, if applicable, is only present for RABs towards the PS domain --,
    dl-N-PDU-SequenceNumber          DL-N-PDU-SequenceNumber          OPTIONAL
    -- This IE, if applicable, is only present for RABs towards the PS domain --,
    ul-N-PDU-SequenceNumber          UL-N-PDU-SequenceNumber          OPTIONAL
    -- This IE, if applicable, is only present for RABs towards the PS domain --,
    iE-Extensions                   ProtocolExtensionContainer { {RAB-
SetupOrModifyItemSecond-ExtIEs} }    OPTIONAL,
    ...
}

RAB-SetupOrModifyItemSecond-ExtIEs RANAP-PROTOCOL-EXTENSION ::= {
    ...
}

RAB-AssignmentRequestExtensions RANAP-PROTOCOL-EXTENSION ::= {
    ...
}

-- *****
--
-- RAB Assignment Response
--
-- *****

RAB-AssignmentResponse ::= SEQUENCE {
    protocolIEs                      ProtocolIE-Container          { {RAB-AssignmentResponseIEs} },
    protocolExtensions               ProtocolExtensionContainer { {RAB-AssignmentResponseExtensions} }
        OPTIONAL,

```

```

...
}

RAB-AssignmentResponseIEs RANAP-PROTOCOL-IES ::= {
  { ID id-RAB-SetupOrModifiedList          CRITICALITY ignore          TYPE RAB-
SetupOrModifiedList          PRESENCE conditional
  -- This group must be present at least when no other group is present, ie. at least one group must be present --
  } |
  { ID id-RAB-ReleasedList                CRITICALITY ignore          TYPE RAB-ReleasedList
  PRESENCE conditional
  -- This group must be present at least when no other group is present, ie. at least one group must be present --
  } |
  { ID id-DL-GTP-PDU-SequenceNumber        CRITICALITY ignore          TYPE DL-GTP-PDU-SequenceNumber
  PRESENCE conditional
  -- This IE is only present for RABs towards the PS domain when the release is UTRAN initiated --
  } |
  { ID id-UL-GTP-PDU-SequenceNumber        CRITICALITY ignore          TYPE UL-GTP-PDU-SequenceNumber
  PRESENCE conditional
  -- This IE is only present for RABs towards the PS domain when the release is UTRAN initiated --
  } |
  { ID id-RAB-QueuedList                   CRITICALITY ignore          TYPE RAB-QueuedList
  PRESENCE conditional
  -- This group must be present at least when no other group is present, ie. at least one group must be present --
  } |
  { ID id-RAB-FailedList                   CRITICALITY ignore          TYPE RAB-FailedList
  PRESENCE conditional
  -- This group must be present at least when no other group is present, ie. at least one group must be present --
  } |
  { ID id-RAB-ReleaseFailedList            CRITICALITY ignore          TYPE RAB-ReleaseFailedList
  PRESENCE conditional
  -- This group must be present at least when no other group is present, ie. at least one group must be present --
  },
  ...
}

RAB-SetupOrModifiedList ::= RAB-IE-ContainerList { {RAB-SetupOrModifiedItemIEs} }

RAB-SetupOrModifiedItemIEs RANAP-PROTOCOL-IES ::= {
  { ID id-RAB-SetupOrModifiedItem          CRITICALITY ignore          TYPE RAB-
SetupOrModifiedItem          PRESENCE mandatory          },
  ...
}

RAB-SetupOrModifiedItem ::= SEQUENCE {
  rAB-ID                                RAB-ID,
  chosenUP-Version                       ChosenUP-Version          OPTIONAL,
  transportLayerAddress                  TransportLayerAddress       OPTIONAL
}

```

```

-- This IE is only present for RABs towards the PS domain --,
iuTransportAssociation                                IuTransportAssociation  OPTIONAL
-- This IE is only present for RABs towards the PS domain --,
iE-Extensions                                        ProtocolExtensionContainer { {RAB-
SetupOrModifiedItem-ExtIEs} }                        OPTIONAL,
...
}

RAB-SetupOrModifiedItem-ExtIEs RANAP-PROTOCOL-EXTENSION ::= {
...
}

RAB-ReleasedList                                     ::= RAB-IE-ContainerList { {RAB-ReleasedItemIEs} }

RAB-ReleasedItemIEs RANAP-PROTOCOL-IES ::= {
  { ID id-RAB-ReleasedItem                            CRITICALITY ignore      TYPE RAB-ReleasedItem
    PRESENCE mandatory                                },
  ...
}

RAB-ReleasedItem ::= SEQUENCE {
  rAB-ID                                               RAB-ID,
  dl-dataVolumes                                       DataVolumeList
  OPTIONAL
  -- This IE is only present if data volume reporting for PS domain is required --,
  iE-Extensions                                        ProtocolExtensionContainer { {RAB-
ReleasedItem-ExtIEs} }                                OPTIONAL,
  ...
}

RAB-ReleasedItem-ExtIEs RANAP-PROTOCOL-EXTENSION ::= {
...
}

DataVolumeList ::= SEQUENCE (SIZE (1..maxNrOfVol)) OF
  SEQUENCE {
    dl-UnsuccessfullyTransmittedDataVolume            UnsuccessfullyTransmittedDataVolume,
    dataVolumeReference                               DataVolumeReference      OPTIONAL,
    iE-Extensions                                    ProtocolExtensionContainer
  { {DataVolumeList-ExtIEs} }                        OPTIONAL,
  ...
  }

DataVolumeList-ExtIEs RANAP-PROTOCOL-EXTENSION ::= {
...
}

```



```

RAB-QueuedList ::= RAB-IE-ContainerList { {RAB-
QueuedItemIEs} }

RAB-QueuedItemIEs RANAP-PROTOCOL-IES ::= {
    { ID id-RAB-QueuedItem
    PRESENCE mandatory },
    ...
}

RAB-QueuedItem ::= SEQUENCE {
    rAB-ID RAB-ID,
    iE-Extensions ProtocolExtensionContainer { {RAB-
QueuedItem-ExtIEs} } OPTIONAL,
    ...
}

RAB-QueuedItem-ExtIEs RANAP-PROTOCOL-EXTENSION ::= {
    ...
}

RAB-ReleaseFailedList ::= RAB-FailedList

RAB-AssignmentResponseExtensions RANAP-PROTOCOL-EXTENSION ::= {
    ...
}

-- *****
--
-- PRIVATE ELEMENTARY PROCEDURE
--
-- *****

PrivateMessage ::= SEQUENCE {
    privateExtensions PrivateExtensionContainer { {PrivateExtensions} },
    ...
}

PrivateExtensions RANAP-PRIVATE-EXTENSION ::= {
    ...
}

END

```

Information Element Definitions

```

-- *****
--
-- Information Element Definitions
--
-- *****

RANAP-IEs -- { object identifier to be allocated }--
DEFINITIONS AUTOMATIC TAGS ::=

BEGIN

IMPORTS

    maxNrOfErrors,
    maxNrOfRABs,
    maxNrOfPoints,
    maxRAB-Subflows,
    maxRAB-SubflowCombination
FROM RANAP-Constants

    Criticality,
    ProcedureCode,
    ProtocolIE-ID,
    TriggeringMessage
FROM RANAP-CommonDataTypes

    ProtocolExtensionContainer{},
    RANAP-PROTOCOL-EXTENSION
FROM RANAP-Containers;

-- A

AllocationOrRetentionPriority ::= SEQUENCE {
    priorityLevel                PriorityLevel,
    pre-emptionCapability        Pre-emptionCapability,
    pre-emptionVulnerability    Pre-emptionVulnerability,
    queuingAllowed              QueuingAllowed,
    iE-Extensions               ProtocolExtensionContainer { {AllocationOrRetentionPriority-
ExtIEs} } OPTIONAL,
    ...
}

AllocationOrRetentionPriority-ExtIEs RANAP-PROTOCOL-EXTENSION ::= {
    ...

```

```
}

AreaIdentity ::= CHOICE {
    sAI                               SAI,
    geographicalArea                   GeographicalArea,
    ...
}

-- B

BindingID ::= OCTET STRING (SIZE (4))

-- C

CategorisationParameters ::= INTEGER (0..15)

Cause ::= CHOICE {
    radioNetwork                       CauseRadioNetwork,
    transmissionNetwork                 CauseTransmissionNetwork,
    nAS                                 CauseNAS,
    protocol                            CauseProtocol,
    misc                                CauseMisc,
    non-Standard                        CauseNon-Standard,
    ...
}

CauseMisc ::= INTEGER {
    om-intervention (129),
    no-resource-available (130),
    unspecified-failure (131),
    network-optimisation (132)
} (129..256)

CauseNAS ::= INTEGER {
    user-restriction-start-indication (81),
    user-restriction-end-indication (82),
    normal-release (83)
} (81..96)

CauseProtocol ::= INTEGER {
    transfer-syntax-error (97)
} (97..112)

CauseRadioNetwork ::= INTEGER {
    rab-pre-empted (1),
    trelocoverall-expiry (2),
    trelocprep-expiry (3),
```

```

    treloccomplete-expiry (4),
    tqueing-expiry (5),
    relocation-triggered (6),
    unable-to-establish-during-relocation (8),
    unknown-target-rnc (9),
    relocation-cancelled (10),
    successful-relocation (11),
    requested-ciphering-and-or-integrity-protection-algorithms-not-supported (12),
    ciphering-and-or-integrity-protection-already-active (13),
    failure-in-the-radio-interface-procedure (14),
    release-due-to-utran-generated-reason (15),
    user-inactivity (16),
    time-critical-relocation (17),
    requested-traffic-class-not-available (18),
    invalid-rab-parameters-value (19),
    requested-maximum-bit-rate-not-available (20),
    requested-guaranteed-bit-rate-not-available (21),
    requested-transfer-delay-not-achievable (22),
    invalid-rab-parameters-combination (23),
    condition-violation-for-sdu-parameters (24),
    condition-violation-for-traffic-handling-priority (25),
    condition-violation-for-guaranteed-bit-rate (26),
    user-plane-versions-not-supported (27),
    iu-up-failure (28)
} (1..64)

CauseNon-Standard ::= INTEGER (129..256)

CauseTransmissionNetwork ::= INTEGER {
    logical-error-unknown-iu-transport-association (65)
} (65..80)

CriticalityDiagnostics ::= SEQUENCE {
    procedureCode                ProcedureCode                OPTIONAL,
    triggeringMessage             TriggeringMessage             OPTIONAL,
    criticalityResponse           Criticality                OPTIONAL,
    iEsCriticalityResponses       CriticalityDiagnostics-IE-List  OPTIONAL,
    iE-Extensions                 ProtocolExtensionContainer { {CriticalityDiagnostics-ExtIEs} }
OPTIONAL,
    ...
}

CriticalityDiagnostics-ExtIEs RANAP-PROTOCOL-EXTENSION ::= {
    ...
}

```

```

CriticalityDiagnostics-IE-List ::= SEQUENCE (SIZE (1..maxNrOfErrors)) OF
    SEQUENCE {
        criticalityResponse          Criticality,
        iE-ID                        ProtocolIE-ID,
        iE-Extensions                ProtocolExtensionContainer {
{CriticalityDiagnostics-IE-List-ExtIEs} } OPTIONAL,
        ...
    }

CriticalityDiagnostics-IE-List-ExtIEs RANAP-PROTOCOL-EXTENSION ::= {
    ...
}

CGI ::= SEQUENCE {
    pLMN-ID                PLMN-ID,
    LAC                    LAC,
    cI                     CI,
    iE-Extensions          ProtocolExtensionContainer { {CGI-ExtIEs} } OPTIONAL
}

CGI-ExtIEs RANAP-PROTOCOL-EXTENSION ::= {
    ...
}

ChosenEncryptionAlgorithm ::= PermittedEncryptionAlgorithms

ChosenIntegrityProtectionAlgorithm ::= PermittedIntegrityProtectionAlgorithms

ChosenUP-Version ::= ENUMERATED {
    version1,
    version2,
    ...
}

CI ::= OCTET STRING (SIZE (2))

ClassmarkInformation2 ::= OCTET STRING

ClassmarkInformation3 ::= OCTET STRING

CN-DomainIndicator ::= ENUMERATED {
    cs-domain,
    ps-domain
}

-- D

```

```

DataVolumeReference ::= INTEGER (0..255)

DataVolumeReportingIndication ::= ENUMERATED {
    do-report,
    do-not-report
}

DeliveryOfErroneousSDU ::= ENUMERATED {
    yes,
    no,
    no-error-detection-consideration
}

DeliveryOrder ::= ENUMERATED {
    delivery-order-requested,
    delivery-order-not-requested
}

DL-GTP-PDU-SequenceNumber ::= INTEGER (0..65535)
-- Reference: xx.xxx

DL-N-PDU-SequenceNumber ::= INTEGER (0..4095)
-- Reference: xx.xxx

D-RNTI ::= OCTET STRING (SIZE (20))

-- E

EncryptionAlgorithm ::= INTEGER { no-encryption (0), standard-UMTS-encryption-algorith-UEA1 (1) } (0..15)

EncryptionInformation ::= SEQUENCE {
    permittedAlgorithms PermittedEncryptionAlgorithms,
    key EncryptionKey,
    iE-Extensions ProtocolExtensionContainer { {EncryptionInformation-ExtIEs} }
OPTIONAL
}

EncryptionInformation-ExtIEs RANAP-PROTOCOL-EXTENSION ::= {
    ...
}

EncryptionKey ::= BIT STRING (SIZE (128))
-- Reference: 33.102

Event ::= ENUMERATED {
    stop,

```

```

        direct,
        change-of-area,
        ...
    }

-- F
-- G

GeographicalArea ::= CHOICE {
    point                               GA-Point,
    pointWithUnCertainty                GA-PointWithUnCertainty,
    polygon                             GA-Polygon,
    ...
}

GeographicalCoordinates ::= SEQUENCE {
    latitudeSign                        ENUMERATED { north, south },
    latitude                            INTEGER (0..8388607),
    longitude                           INTEGER (-8388608..8388607),
    iE-Extensions                       ProtocolExtensionContainer { {GeographicalCoordinates-ExtIEs} }
OPTIONAL,
    ...
}

GeographicalCoordinates-ExtIEs RANAP-PROTOCOL-EXTENSION ::= {
    ...
}

GA-Point ::= SEQUENCE {
    geographicalCoordinates              GeographicalCoordinates,
    iE-Extensions                       ProtocolExtensionContainer { {GA-Point-ExtIEs} } OPTIONAL,
    ...
}

GA-Point-ExtIEs RANAP-PROTOCOL-EXTENSION ::= {
    ...
}

GA-PointWithUnCertainty ::= SEQUENCE {
    geographicalCoordinates              GeographicalCoordinates,
    iE-Extensions                       ProtocolExtensionContainer { {GA-PointWithUnCertainty-ExtIEs} }
OPTIONAL,
    uncertaintyCode                     INTEGER (0..127)
}

GA-PointWithUnCertainty-ExtIEs RANAP-PROTOCOL-EXTENSION ::= {
    ...
}

```

```

}

GA-Polygon ::= SEQUENCE (SIZE (1..maxNrOfPoints)) OF
    SEQUENCE {
        geographicalCoordinates      GeographicalCoordinates,
        iE-Extensions                 ProtocolExtensionContainer { {GA-Polygon-ExtIEs} }
    }
OPTIONAL,
    ...
}

GA-Polygon-ExtIEs RANAP-PROTOCOL-EXTENSION ::= {
    ...
}

GlobalRNC-ID ::= SEQUENCE {
    pLMN-ID          PLMN-ID,
    rNC-ID           RNC-ID,
    iE-Extensions   ProtocolExtensionContainer { {GlobalRNC-ID-ExtIEs} } OPTIONAL
}

GlobalRNC-ID-ExtIEs RANAP-PROTOCOL-EXTENSION ::= {
    ...
}

GTP-TEI ::= OCTET STRING (SIZE (4))
-- Reference: xx.xxx

GuaranteedBitrate ::= INTEGER (0..16000000)
-- Unit is bits per sec

-- H

-- I

IMEI ::= TBCD-STRING (SIZE (8))
-- Reference: 23.003

IMSI ::= TBCD-STRING (SIZE (3..8))
-- Reference: 23.003

IntegrityProtectionAlgorithm ::= INTEGER { standard-UMTS-integrity-algorithm-UIA1 (0) } (0..15)

IntegrityProtectionInformation ::= SEQUENCE {
    permittedAlgorithms      PermittedIntegrityProtectionAlgorithms,
    key                      IntegrityProtectionKey,
    iE-Extensions           ProtocolExtensionContainer { {IntegrityProtectionInformation-
ExtIEs} } OPTIONAL
}

```



```

}

IntegrityProtectionInformation-ExtIEs RANAP-PROTOCOL-EXTENSION ::= {
    ...
}

IntegrityProtectionKey ::= BIT STRING (SIZE (128))

IuTransportAssociation ::= CHOICE {
    gTP-TEI                GTP-TEI,
    bindingID              BindingID,
    ...
}

-- J
-- K
-- L

LAC ::= OCTET STRING (SIZE (2))

LAI ::= SEQUENCE {
    pLMN-ID                PLMN-ID,
    LAC                    LAC,
    iE-Extensions          ProtocolExtensionContainer { {LAI-ExtIEs} } OPTIONAL
}

LAI-ExtIEs RANAP-PROTOCOL-EXTENSION ::= {
    ...
}

L3-Information ::= OCTET STRING

-- M

MaxBitrate ::= INTEGER (0..16000000)
-- Unit is bits per sec

MaxSDU-Size ::= INTEGER
-- MaxSDU-Size ::= INTEGER (0..32768)
-- Unit is bit

MCC ::= TBCD-STRING (SIZE (2))
-- Reference: 24.008

MNC ::= TBCD-STRING (SIZE (2))
-- Reference: 24.008

```

```
-- N

NAS-BindingInformation ::= OCTET STRING (SIZE (2))

NAS-BroadcastInformation ::= OCTET STRING

NAS-PDU ::= OCTET STRING

NonSearchingIndication ::= ENUMERATED {
    non-searching,
    searching
}

NumberOfIuInstances ::= INTEGER (1..2)

NumberOfSteps ::= INTEGER (1..16)

-- O

OldBSS-ToNewBSS-Information ::= OCTET STRING

OMC-ID ::= OCTET STRING (SIZE (3..22))
-- Reference: GSM TS 12.20

-- P

PagingAreaID ::= CHOICE {
    LAI LAI,
    rAI RAI,
    ...
}

PagingCause ::= ENUMERATED {
    speech-call,
    cs-data-call,
    ps-data-call,
    sms,
    ...
}

PermanentNAS-UE-ID ::= CHOICE {
    IMSI IMSI,
    ...
}

PermittedEncryptionAlgorithms ::= SEQUENCE (SIZE (0..15)) OF
    EncryptionAlgorithm
```

```

PermittedIntegrityProtectionAlgorithms ::= SEQUENCE (SIZE (0..15)) OF
    IntegrityProtectionAlgorithm

PLMN-ID                               ::= TBCD-STRING (SIZE (3))

Pre-emptionCapability ::= ENUMERATED {
    can-not-trigger-pre-emption,
    can-trigger-pre-emption
}

Pre-emptionVulnerability ::= ENUMERATED {
    not-vulnerable-to-pre-emption,
    vulnerable-to-pre-emption
}

PriorityLevel                          ::= INTEGER { spare (0), highest (1), lowest (14), no-priority
(15) } (0..15)

P-TMSI                                 ::= OCTET STRING (SIZE (4))

-- Q

QueuingAllowed ::= ENUMERATED {
    queueing-not-allowed,
    queueing-allowed
}

-- R

RAB-ID                                 ::= INTEGER (1..maxNrOfRABs)

RAB-Parameters ::= SEQUENCE {
    trafficClass                        TrafficClass,
    maxBitrate                          MaxBitrate,
    guaranteedBitRate                   GuaranteedBitrate,
    deliveryOrder                       DeliveryOrder,
    maxSDU-Size                         MaxSDU-Size,
    sDU-Parameters                      SDU-Parameters,
    transferDelay                       TransferDelay,
    trafficHandlingPriority              TrafficHandlingPriority,
    allocationOrRetentionPriority        AllocationOrRetentionPriority,
    sourceStatisticsDescriptor           SourceStatisticsDescriptor,
    iE-Extensions                       ProtocolExtensionContainer { {RAB-Parameters-ExtIEs} } OPTIONAL,
    ...
}

```

```

RAB-Parameters-ExtIEs RANAP-PROTOCOL-EXTENSION ::= {
    ...
}

RAC ::= OCTET STRING (SIZE (1))

RAI ::= SEQUENCE {
    LAI,
    rAC,
    iE-Extensions
    ...
}

RAI-ExtIEs RANAP-PROTOCOL-EXTENSION ::= {
    ...
}

RateControlAllowed ::= ENUMERATED {
    not-allowed,
    allowed
}

RelocationType ::= ENUMERATED {
    ue-not-involved,
    ue-involved,
    ...
}

ReportArea ::= ENUMERATED {
    service-area,
    geographical-coordinates,
    ...
}

RequestType ::= SEQUENCE {
    event,
    reportArea,
    ...
}

ResidualBitErrorRatio ::= CHOICE {
    notApplicable,
    value
}

ResidualBitErrorRatioIE ::= SEQUENCE {
    mantissa,
    INTEGER (1..9),
}

```

```

        exponent                INTEGER (1..8),
        iE-Extensions            ProtocolExtensionContainer { {ResidualBitErrorRatioIE-ExtIEs} }
OPTIONAL
}
-- ResidualBitErrorRatio = mantissa * 10^-exponent

ResidualBitErrorRatioIE-ExtIEs RANAP-PROTOCOL-EXTENSION ::= {
    ...
}

RNC-ID                          ::= INTEGER (0..4095)
-- RNC-ID                        ::= BIT STRING (SIZE (12))
-- Harmonized with RNSAP and NBAP definitions

RRC-Container                    ::= OCTET STRING

-- S

SAC                              ::= OCTET STRING (SIZE (2))

SAI ::= SEQUENCE {
    pLMN-ID                      PLMN-ID,
    LAC                          LAC,
    SAC                          SAC,
    iE-Extensions                ProtocolExtensionContainer { {SAI-ExtIEs} } OPTIONAL
}

SAI-ExtIEs RANAP-PROTOCOL-EXTENSION ::= {
    ...
}

SAPI ::= ENUMERATED {
    normal-priority,
    low-priority,
    ...
}

SDU-ErrorRatio ::= CHOICE {
    notApplicable                NULL,
    value                        SDU-ErrorRatioIE
}

SDU-ErrorRatioIE ::= SEQUENCE {
    mantissa                     INTEGER (1..9),
    exponent                     INTEGER (1..6),
    iE-Extensions                ProtocolExtensionContainer { {SDU-ErrorRatioIE-ExtIEs} }
OPTIONAL

```

```

}
-- ErrorRatio = mantissa * 10^-exponent

SDU-ErrorRatioIE-ExtIEs RANAP-PROTOCOL-EXTENSION ::= {
    ...
}

SDU-Parameters ::= SEQUENCE (SIZE (1..maxRAB-Subflows)) OF
    SEQUENCE {
        SDU-ErrorRatio                SDU-ErrorRatio,
        residualBitErrorRatio          ResidualBitErrorRatio,
        deliveryOfErroneousSDU         DeliveryOfErroneousSDU,
        subflowSDU-SizeParameters     SubflowSDU-SizeParameters,
        iE-Extensions                 ProtocolExtensionContainer { {SDU-Parameters-ExtIEs}
    } OPTIONAL,
    ...
}
-- SDU-ErrorRatio is set to notApplicable when DeliveryOfErroneousSDU is
-- set to no-error-detection-consideration.

SDU-Parameters-ExtIEs RANAP-PROTOCOL-EXTENSION ::= {
    ...
}

SourceID ::= CHOICE {
    sourceRNC-ID                      SourceRNC-ID, -- If UMTS target
    sAI                                SAI,          -- if GSM target
    ...
}

SourceRNC-ID ::= GlobalRNC-ID

SourceRNC-ToTargetRNC-TransparentContainer ::= SEQUENCE {
    rRC-Container                      RRC-Container,
    numberOfIuInstances                NumberOfIuInstances,
    relocationType                     RelocationType,
    chosenIntegrityProtectionAlgorithm ChosenIntegrityProtectionAlgorithm    OPTIONAL
    -- Must be present for intra UMTS Handovers --,
    integrityProtectionKey              IntegrityProtectionKey                OPTIONAL
    -- Must be present for intra UMTS Handovers --,
    chosenEncryptionAlgorithmForSignalling ChosenEncryptionAlgorithm          OPTIONAL
    -- Must be present for intra UMTS Handovers if ciphering is active --,
    cipheringKey                        EncryptionKey                          OPTIONAL
    -- Must be present for intra UMTS Handovers if ciphering is active --,
    chosenEncryptionAlgorithmForCS       ChosenEncryptionAlgorithm          OPTIONAL
    -- Must be present for intra UMTS Handovers if ciphering is active --,
    chosenEncryptionAlgorithmForPS       ChosenEncryptionAlgorithm          OPTIONAL
}

```

```

    -- Must be present for intra UMTS Handovers if ciphering is active --,
    d-RNTI                               D-RNTI
    OPTIONAL,
    iE-Extensions                         ProtocolExtensionContainer { {SourceRNC-ToTargetRNC-
TransparentContainer-ExtIEs} } OPTIONAL,
    ...
}

SourceRNC-ToTargetRNC-TransparentContainer-ExtIEs RANAP-PROTOCOL-EXTENSION ::= {
    ...
}

SourceStatisticsDescriptor ::= ENUMERATED {
    na,
    speech,
    unknown,
    ...
}

SubflowSDU-Size                               ::= INTEGER (0..4095)
-- Unit is bit

SubflowSDU-SizeParameters ::= SEQUENCE (SIZE (1..maxRAB-SubflowCombination)) OF
    SEQUENCE {
        rateControlAllowed                RateControlAllowed,
        subflowSDU-Size                    SubflowSDU-Size           OPTIONAL
        -- This IE is only present for RABs that have predefined SDU size(s) --,
        iE-Extensions                       ProtocolExtensionContainer { {SubflowSDU-
SizeParameters-ExtIEs} } OPTIONAL,
        ...
    }

SubflowSDU-SizeParameters-ExtIEs RANAP-PROTOCOL-EXTENSION ::= {
    ...
}

-- T

TargetID ::= CHOICE {
    targetRNC-ID                            TargetRNC-ID, -- If UMTS target
    CGI                                       CGI,           -- If GSM target
    ...
}

TargetRNC-ID                               ::= GlobalRNC-ID

TargetRNC-ToSourceRNC-TransparentContainer ::= SEQUENCE {

```

```

        rRC-Container
        iE-Extensions
TransparentContainer-ExtIEs} } OPTIONAL,
        ...
}

TargetRNC-ToSourceRNC-TransparentContainer-ExtIEs RANAP-PROTOCOL-EXTENSION ::= {
        ...
}

TBCD-STRING ::= OCTET STRING

TemporaryUE-ID ::= CHOICE {
        tMSI
        p-TMSI
        ...
}

TMSI ::= OCTET STRING (SIZE (4))

TraceReference ::= OCTET STRING (SIZE (2..3))

TraceType ::= OCTET STRING (SIZE (1))
-- Reference: GSM TS 12.08

TrafficClass ::= ENUMERATED {
        conversational,
        streaming,
        interactive,
        background,
        ...
}

TrafficHandlingPriority ::= INTEGER { spare (0), highest (1), lowest (14), no-priority-used (15) } (0..15)

TransferDelay ::= INTEGER (0..65535)
-- Unit is millisecond

UnsuccessfullyTransmittedDataVolume ::= INTEGER (0..4294967295)

TransportLayerAddress ::= OCTET STRING (SIZE (20))

TriggerID ::= OCTET STRING (SIZE (3..22))

-- U

UE-ID ::= CHOICE {

```



```

        imsi
        imei
        ...
    }

UL-GTP-PDU-SequenceNumber ::= INTEGER (0..65535)

UL-N-PDU-SequenceNumber ::= INTEGER (0..4095)

UP-ModeVersions ::= BIT STRING (SIZE (16))

UserPlaneMode ::= ENUMERATED {
    transparent-mode,
    support-mode-for-predefined-SDU-sizes,
    ...
}

END

```

Common Definitions

```

-- *****
--
-- Common definitions
--
-- *****

RANAP-CommonDataTypes -- { object identifier to be allocated }--
DEFINITIONS AUTOMATIC TAGS ::=

BEGIN

Criticality ::= ENUMERATED { reject, ignore, notify }

Presence ::= ENUMERATED { optional, conditional, mandatory }

PrivateExtensionID ::= CHOICE {
    local          INTEGER (0..65535),
    global        OBJECT IDENTIFIER
}

ProcedureCode ::= INTEGER (0..255)

ProtocolExtensionID ::= INTEGER (0..65535)

```

```

ProtocolIE-ID                ::= INTEGER (0..65535)

TriggeringMessage            ::= ENUMERATED { initiating-message, successful-outcome, unsuccessful-outcome, outcome }

END

```

Constant Definitions

```

-- *****
--
-- Constant definitions
--
-- *****

RANAP-Constants -- { object identifier to be allocated }--
DEFINITIONS AUTOMATIC TAGS ::=

BEGIN

-- *****
--
-- Elementary Procedures
--
-- *****

id-RAB-Assignment            INTEGER ::= 0
id-Iu-Release                INTEGER ::= 1
id-RelocationPreparation     INTEGER ::= 2
id-RelocationResourceAllocation INTEGER ::= 3
id-RelocationCancel          INTEGER ::= 4
id-SRNS-ContextTransfer      INTEGER ::= 5
id-SecurityModeControl       INTEGER ::= 6
id-DataVolumeReport          INTEGER ::= 7
id-CN-InformationBroadcast    INTEGER ::= 8
id-Reset                     INTEGER ::= 9
id-RAB-ReleaseRequest        INTEGER ::= 10
id-Iu-ReleaseRequest         INTEGER ::= 11
id-RelocationDetect          INTEGER ::= 12
id-RelocationComplete        INTEGER ::= 13
id-Paging                    INTEGER ::= 14
id-CommonID                  INTEGER ::= 15

```

```

id-CN-InvokeTrace                INTEGER ::= 16
id-LocationReportingControl       INTEGER ::= 17
id-LocationReport                INTEGER ::= 18
id-InitialUE-Message             INTEGER ::= 19
id-DirectTransfer                 INTEGER ::= 20
id-OverloadControl               INTEGER ::= 21
id-ErrorIndication               INTEGER ::= 22
id-SRNS-DataForward              INTEGER ::= 23
id-ForwardSRNS-Context           INTEGER ::= 24
id-Private                       INTEGER ::= 25

-- *****
--
-- Extension constants
--
-- *****

maxPrivateExtensions              INTEGER ::= 65535
maxProtocolExtensions            INTEGER ::= 65535
maxProtocolIEs                   INTEGER ::= 65535

-- *****
--
-- Lists
--
-- *****

maxNrOfErrors                    INTEGER ::= 256
maxNrOfPieces                    INTEGER ::= 16
maxNrOfRABs                      INTEGER ::= 256
maxNrOfVol                       INTEGER ::= 2
maxNrOfPoints                    INTEGER ::= 15

maxRAB-Subflows                  INTEGER ::= 7
maxRAB-SubflowCombination        INTEGER ::= 64

-- *****
--
-- IEs
--
-- *****

id-AreaIdentity                  INTEGER ::= 0
id-CN-BroadcastInformationPiece  INTEGER ::= 1
id-CN-BroadcastInformationPieceList INTEGER ::= 2
id-CN-DomainIndicator           INTEGER ::= 3
id-Cause                        INTEGER ::= 4

```

id-ChosenEncryptionAlgorithm	INTEGER ::= 5
id-ChosenIntegrityProtectionAlgorithm	INTEGER ::= 6
id-ClassmarkInformation2	INTEGER ::= 7
id-ClassmarkInformation3	INTEGER ::= 8
id-CriticalityDiagnostics	INTEGER ::= 9
id-DL-GTP-PDU-SequenceNumber	INTEGER ::= 10
id-EncryptionInformation	INTEGER ::= 11
id-IntegrityProtectionInformation	INTEGER ::= 12
id-IuTransportAssociation	INTEGER ::= 13
id-L3-Information	INTEGER ::= 14
id-LAI	INTEGER ::= 15
id-NAS-PDU	INTEGER ::= 16
id-NonSearchingIndication	INTEGER ::= 17
id-NumberOfSteps	INTEGER ::= 18
id-OMC-ID	INTEGER ::= 19
id-OldBSS-ToNewBSS-Information	INTEGER ::= 20
id-PagingAreaID	INTEGER ::= 21
id-PagingCause	INTEGER ::= 22
id-PermanentNAS-UE-ID	INTEGER ::= 23
id-RAB-ContextItem	INTEGER ::= 24
id-RAB-ContextList	INTEGER ::= 25
id-RAB-DataForwardingItem	INTEGER ::= 26
id-RAB-DataForwardingItem-SRNS-CtxReq	INTEGER ::= 27
id-RAB-DataForwardingList	INTEGER ::= 28
id-RAB-DataForwardingList-SRNS-CtxReq	INTEGER ::= 29
id-RAB-DataVolumeReportItem	INTEGER ::= 30
id-RAB-DataVolumeReportList	INTEGER ::= 31
id-RAB-DataVolumeReportRequestItem	INTEGER ::= 32
id-RAB-DataVolumeReportRequestList	INTEGER ::= 33
id-RAB-FailedItem	INTEGER ::= 34
id-RAB-FailedList	INTEGER ::= 35
id-RAB-ID	INTEGER ::= 36
id-RAB-QueuedItem	INTEGER ::= 37
id-RAB-QueuedList	INTEGER ::= 38
id-RAB-ReleaseFailedList	INTEGER ::= 39
id-RAB-ReleaseItem	INTEGER ::= 40
id-RAB-ReleaseList	INTEGER ::= 41
id-RAB-ReleasedItem	INTEGER ::= 42
id-RAB-ReleasedList	INTEGER ::= 43
id-RAB-ReleasedList-IuRelComp	INTEGER ::= 44
id-RAB-RelocationReleaseItem	INTEGER ::= 45
id-RAB-RelocationReleaseList	INTEGER ::= 46
id-RAB-SetupItem-RelocReq	INTEGER ::= 47
id-RAB-SetupItem-RelocReqAck	INTEGER ::= 48
id-RAB-SetupList-RelocReq	INTEGER ::= 49
id-RAB-SetupList-RelocReqAck	INTEGER ::= 50
id-RAB-SetupOrModifiedItem	INTEGER ::= 51

```

id-RAB-SetupOrModifiedList          INTEGER ::= 52
id-RAB-SetupOrModifyItem            INTEGER ::= 53
id-RAB-SetupOrModifyList           INTEGER ::= 54
id-RAC                               INTEGER ::= 55
id-RelocationType                   INTEGER ::= 56
id-RequestType                      INTEGER ::= 57
id-SAI                              INTEGER ::= 58
id-SAPI                             INTEGER ::= 59
id-SourceID                         INTEGER ::= 60
id-SourceRNC-ToTargetRNC-TransparentContainer  INTEGER ::= 61
id-TargetID                         INTEGER ::= 62
id-TargetRNC-ToSourceRNC-TransparentContainer  INTEGER ::= 63
id-TemporaryUE-ID                   INTEGER ::= 64
id-TraceReference                   INTEGER ::= 65
id-TraceType                        INTEGER ::= 66
id-TransportLayerAddress            INTEGER ::= 67
id-TriggerID                        INTEGER ::= 68
id-UE-ID                            INTEGER ::= 69
id-UL-GTP-PDU-SequenceNumber       INTEGER ::= 70

END

```

Container Definitions

```

-- *****
--
-- Container definitions
--
-- *****

RANAP-Containers -- { object identifier to be allocated }--
DEFINITIONS AUTOMATIC TAGS ::=

BEGIN

-- *****
--
-- IE parameter types from other modules.
--
-- *****

IMPORTS

    Criticality,

```

```

        Presence,
        PrivateExtensionID,
        ProtocolExtensionID,
        ProtocolIE-ID
FROM RANAP-CommonDataTypes

        maxPrivateExtensions,
        maxProtocolExtensions,
        maxProtocolIEs
FROM RANAP-Constants;

-- *****
--
-- Class Definition for Protocol IEs
--
-- *****

RANAP-PROTOCOL-IES ::= CLASS {
        &id                               ProtocolIE-ID
        UNIQUE,
        &criticality                       Criticality,
        &Value,
        &presence                           Presence
}
WITH SYNTAX {
        ID                               &id
        CRITICALITY                       &criticality
        TYPE                               &Value
        PRESENCE                           &presence
}

-- *****
--
-- Class Definition for Protocol IEs
--
-- *****

RANAP-PROTOCOL-IES-PAIR ::= CLASS {
        &id                               ProtocolIE-ID
        UNIQUE,
        &firstCriticality                   Criticality,
        &FirstValue,
        &secondCriticality                   Criticality,
        &SecondValue,
        &presence                           Presence
}
WITH SYNTAX {

```

```

        ID                                &id
        FIRST CRITICALITY                 &firstCriticality
        FIRST TYPE                         &FirstValue
        SECOND CRITICALITY                &secondCriticality
        SECOND TYPE                       &SecondValue
        PRESENCE                          &presence
    }

-- *****
--
-- Class Definition for Protocol Extensions
--
-- *****

RANAP-PROTOCOL-EXTENSION ::= CLASS {
    &id                                ProtocolExtensionID
    UNIQUE,
    &criticality                       Criticality,
    &Extension
}
WITH SYNTAX {
    ID                                &id
    CRITICALITY                       &criticality
    EXTENSION                          &Extension
}

-- *****
--
-- Class Definition for Private Extensions
--
-- *****

RANAP-PRIVATE-EXTENSION ::= CLASS {
    &id                                PrivateExtensionID,
    &criticality                       Criticality,
    &Extension
}
WITH SYNTAX {
    ID                                &id
    CRITICALITY                       &criticality
    EXTENSION                          &Extension
}

-- *****
--
-- Container for Protocol IEs
--

```

```

-- *****

ProtocolIE-Container {RANAP-PROTOCOL-IES : IEsSetParam} ::=
    SEQUENCE (SIZE (0..maxProtocolIEs)) OF
        ProtocolIE-Field {{IEsSetParam}}

ProtocolIE-Field {RANAP-PROTOCOL-IES : IEsSetParam} ::= SEQUENCE {
    id                                RANAP-PROTOCOL-IES.&id
    ({IEsSetParam}),
    criticality                        RANAP-PROTOCOL-IES.&criticality
    ({IEsSetParam}{@id}),
    value                              RANAP-PROTOCOL-IES.&Value
    ({IEsSetParam}{@id})
}

-- *****
--
-- Container for Protocol IE Pairs
--
-- *****

ProtocolIE-ContainerPair {RANAP-PROTOCOL-IES-PAIR : IEsSetParam} ::=
    SEQUENCE (SIZE (0..maxProtocolIEs)) OF
        ProtocolIE-FieldPair {{IEsSetParam}}

ProtocolIE-FieldPair {RANAP-PROTOCOL-IES-PAIR : IEsSetParam} ::= SEQUENCE {
    id                                RANAP-PROTOCOL-IES-PAIR.&id
    ({IEsSetParam}),
    firstCriticality                  RANAP-PROTOCOL-IES-PAIR.&firstCriticality    ({IEsSetParam}{@id}),
    firstValue                        RANAP-PROTOCOL-IES-PAIR.&FirstValue        ({IEsSetParam}{@id}),
    secondCriticality                  RANAP-PROTOCOL-IES-PAIR.&secondCriticality    ({IEsSetParam}{@id}),
    secondValue                        RANAP-PROTOCOL-IES-PAIR.&SecondValue        ({IEsSetParam}{@id})
}

-- *****
--
-- Container Lists for Protocol IE Containers
--
-- *****

ProtocolIE-ContainerList {INTEGER : lowerBound, INTEGER : upperBound, RANAP-PROTOCOL-IES : IEsSetParam} ::=
    SEQUENCE (SIZE (lowerBound..upperBound)) OF
        ProtocolIE-Container {{IEsSetParam}}

ProtocolIE-ContainerPairList {INTEGER : lowerBound, INTEGER : upperBound, RANAP-PROTOCOL-IES-PAIR : IEsSetParam} ::=
    SEQUENCE (SIZE (lowerBound..upperBound)) OF
        ProtocolIE-ContainerPair {{IEsSetParam}}

```



```

-- *****
--
-- Container for Protocol Extensions
--
-- *****

ProtocolExtensionContainer {RANAP-PROTOCOL-EXTENSION : ExtensionSetParam} ::=
    SEQUENCE (SIZE (1..maxProtocolExtensions)) OF
        ProtocolExtensionField {{ExtensionSetParam}}

ProtocolExtensionField {RANAP-PROTOCOL-EXTENSION : ExtensionSetParam} ::= SEQUENCE {
    id                                     RANAP-PROTOCOL-EXTENSION.&id
    ( {ExtensionSetParam} ),
    criticality                           RANAP-PROTOCOL-EXTENSION.&criticality      ( {ExtensionSetParam}{@id} ),
    extensionValue                         RANAP-PROTOCOL-EXTENSION.&Extension
    ( {ExtensionSetParam}{@id} )
}

-- *****
--
-- Container for Private Extensions
--
-- *****

PrivateExtensionContainer {RANAP-PRIVATE-EXTENSION : ExtensionSetParam} ::=
    SEQUENCE (SIZE (1..maxPrivateExtensions)) OF
        PrivateExtensionField {{ExtensionSetParam}}

PrivateExtensionField {RANAP-PRIVATE-EXTENSION : ExtensionSetParam} ::= SEQUENCE {
    id                                     RANAP-PRIVATE-EXTENSION.&id
    ( {ExtensionSetParam} ),
    criticality                           RANAP-PRIVATE-EXTENSION.&criticality      ( {ExtensionSetParam}{@id} ),
    extensionValue                         RANAP-PRIVATE-EXTENSION.&Extension
    ( {ExtensionSetParam}{@id} )
}

END

```

Message Transfer Syntax

RANAP shall use the ASN.1 Packed Encoding Rules (PER) Aligned Variant as transfer syntax as specified in ref. [13].

Timers

$T_{\text{RELOCprep}}$

Specifies the maximum time for *Relocation Preparation* in the source RNC.

$T_{\text{RELOCoverall}}$

Specifies the maximum time for the protection of overall Relocation procedure in the source RNC.

$T_{\text{RELOCalloc}}$

Specifies the maximum time for *Relocation Resource Allocation* in the CN.

$T_{\text{RELOCcomplete}}$

Specifies the maximum time for waiting the relocation completion in the CN.

T_{RABAssgt}

Specifies the maximum time in the CN for the whole *RAB Assignment* and *Queuing* procedures.

T_{QUEUING}

Specifies the maximum time in the RNC for queuing of the request of RAB establishment or modification.

T_{DATAfwd}

Specifies the maximum time for GTP-PDU forwarding at the source RNC during relocation of SRNS.

T_{igOC}

While this timer is running, all *OVERLOAD* messages or signalling point congested information received at the CN are ignored.

T_{igOR}

While this timer is running, all *OVERLOAD* messages or signalling point congested information received at the RNC are ignored.

T_{inTC}

While this timer is running, the CN is not allowed to increase traffic.

T_{inTR}

While this timer is running, the RNC is not allowed to increase traffic.

T_{RafC}

Specifies the maximum time for *Reset* in the RNC.

T_{RatC}

Specifies a guard period in the RNC before sending a *RESET ACKNOWLEDGE* message.

T_{RafR}

Specifies the maximum time for *Reset* in the CN.

T_{RatR}

Specifies a guard period in the CN before sending a *RESET ACKNOWLEDGE* message.

Handling of Unknown, Unforeseen and Erroneous Protocol Data

10.1 General

Protocol Error cases can be divided into two classes:

1. Transfer Syntax error
2. Abstract Syntax error

10.2 Transfer Syntax Error

A Transfer Syntax Error occurs when the receiver is not able to decode the received message i.e. the transfer syntax can not be opened. If Transfer Syntax Error occurs, the receiver should initiate Error Indication procedure with appropriate cause value for the protocol error.

10.3 Abstract Syntax Error

10.3.1 General

In the RANAP messages there is criticality information set for individual IEs and/or sequences of IEs. This criticality information instructs the receiver how to act when receiving an IE that is not comprehended. An IE shall be regarded as not comprehended if the receiving node either cannot decode the IE or does not comprehend the function represented by the IE value. The case of the not comprehended IE is an Abstract Syntax Error.

If an Abstract Syntax Error occurs, the receiver shall read the remaining message and shall then for each detected Abstract Syntax Error act according to the Criticality Information for the IE or sequences of IEs due to which Abstract Syntax Error occurred in accordance with chapter 10.3.2.

The receiving node shall take different actions depending on the value of the Criticality Information. The three possible values of the Criticality Information are:

1. Reject IE
2. Ignore IE and Notify Sender
3. Ignore IE

10.3.2 Handling of the Criticality Information at Reception

10.3.2.1 Procedure Code

The receiving node shall treat the different types of criticality information of the *Procedure Code* according to the following:

Reject IE:

If a message is received with a *Procedure Code* marked with “*Reject IE*” which the receiving node does not comprehend, the receiving node shall reject the procedure using the Error Indication procedure.

Ignore IE and Notify Sender:

If a message is received with a *Procedure Code* marked with “*Ignore IE and Notify Sender*” which the receiving node does not comprehend, the receiving node shall ignore the procedure and initiate the Error Indication procedure.

Ignore IE:

If a message is received with a *Procedure Code* marked with “*Ignore IE*” which the receiving node does not comprehend, the receiving node shall ignore the procedure.

10.3.2.2 IEs other than the Procedure Code

The receiving node shall treat the different types of criticality information of an IE other than the *Procedure Code* according to the following:

Reject IE:

If a message *initiating* a procedure is received containing one or more IEs marked with “*Reject IE*” which the receiving node does not comprehend; none of the functional requests of the message shall be executed. The receiving node shall reject the procedure and report the rejection of one or more IEs using the message normally used to report unsuccessful outcome of the procedure.

If a message *initiating* a procedure that does not have a message to report unsuccessful outcome is received containing one or more IEs marked with “*Reject IE*” which the receiving node does not comprehend, the receiving node shall initiate the Error Indication procedure.

If a *response* message is received containing one or more IEs marked with “*Reject IE*”, the receiving node shall initiate local error handling.

Ignore IE and Notify Sender:

If a message *initiating* a procedure is received containing one or more IEs marked with “*Ignore IE and Notify Sender*” which the receiving node does not comprehend, the receiving node shall continue with the procedure using the understood IEs and report that one or more IEs have been ignored in the response message of the procedure.

If a *response* message is received containing one or more IEs marked with “*Ignore IE and Notify Sender*” which the receiving node does not comprehend, the receiving node shall ignore the IE and initiate the Error Indication procedure.

Ignore IE:

If a message *initiating* a procedure is received containing one or more IEs marked with “*Ignore IE*” which the receiving node does not comprehend, the receiving node shall continue with the procedure using the understood IEs.

10.4 Logical Error Handling

Logical error situations occur when a message is comprehended correctly, but the information contained within the message is not valid (i.e. semantic error), or describes a procedure which is not compatible with the state of the receiver. In these conditions, the following behaviour shall be performed as defined by the class of the elementary procedure, irrespective of the criticality of the IE's containing the erroneous values.

Class 1:

Where the logical error occurs in a request message of a class 1 procedure, and the procedure has a failure message, the failure message shall be sent with an appropriate cause value. Typical cause values are:

- Semantic Error
- Message not compatible with receiver state

Where the logical error is contained in a request message of a class 1 procedure, and the procedure does not have a failure message, the ERROR INDICATION procedure shall be initiated with an appropriate cause value.

Where the logical error exists in a response message of a class 1 procedure, local error handling shall be initiated.

Class 2:

Where the logical error occurs in a message of a class 2 procedure, the ERROR INDICATION procedure shall be initiated with an appropriate cause value.

Class 3:

Where the logical error occurs in a request message of a class 3 procedure, and the procedure has a failure message, the failure message shall be sent with an appropriate cause value. Typical cause values are:

- Semantic Error
- Message not compatible with receiver state

Where the logical error is contained in a request message of a class 3 procedure, and the procedure does not have a failure message, the ERROR INDICATION procedure shall be initiated with an appropriate cause value.

Where the logical error exists in a response message of a class 3 procedure, local error handling shall be initiated.

History

Document history		
0.0.1	February 1999	Document skeleton created.
0.0.2	February 1999	Relevant sections from Merged "Description of Iu Interface" have been introduced.
0.0.3	March 1999	The results of the solved study items Iu/2, Iu/3, Iu/4 and Iu/6 have been updated to the text. The heading of section 8 has been changed to "RANAP procedures".

0.0.4	April 1999	<p>Editorial changes:</p> <ul style="list-style-type: none"> - References to "Merged Description of Iu Interface" have been removed. - Remaining instances of Signalling Channel Setup and Response procedure have been removed. - In Hard HO procedure it has been corrected that target RNC receives RELOCATION COMMIT message from source RNC.
0.0.5	April 1999	<p>Editorial changes:</p> <ul style="list-style-type: none"> - Words "Radio Access", related to radio access bearer setup, reconfiguration and release messages, have been added in front of those messages where it was missing. - RAB Release procedure updated to return RAB ASSIGNMENT COMPLETE message before User plane release.
0.1.0	April 1999	Same as 0.0.5, approved by WG3.
1.0.0	April 1999	Approved by TSG RAN. Same contents as 0.1.0.
1.0.1	May 1999	<p>Main updates made based on WG3 meeting #3 and other decisions:</p> <ul style="list-style-type: none"> • Specification number changed to UMTS 25.413. • Title changed to UTRAN Iu Interface RANAP Signalling. • SRNS Relocation and Inter RNS Hard HO procedures merged to a Relocation procedure with a split to elementary procedures according to Tdoc R3-99339 with agreed modifications. The merging was possible based on the approved Tdoc R3-99340, which added RELOCATION DETECT message to the SRNS Relocation procedure. • A statement in the Relocation procedure added related to the load sharing on the Iu-PS interface, according to Tdoc R3-99257 with modifications. • <i>Location Request</i> and <i>Location Report</i> procedures added according to Tdoc R3-99358 with agreed modifications. • Information elements for Relocation procedure have been added according to Tdoc R3-99328 with modifications.
1.0.2	June 1999	<p>Main updates made based on WG3 meeting #4 decisions:</p> <ul style="list-style-type: none"> • <i>Relocation Required Indication</i> procedure replaced by <i>Relocation Preparation</i> procedure according to R3-99477 with agreed modifications. • It was decided to use combined <i>RAB Assignment</i> procedure based on solved Study item Iu/5. • <i>Location Request</i> procedure was replaced by <i>Location Reporting Control</i> procedure according to R3-99475 with agreed modifications. • <i>RANAP Error Indication</i> procedure was introduced according to R3-99456. • CN domain indicator to <i>Paging</i> procedure was accepted according to R3-99461. • Information elements for <i>RAB Assignment</i> procedure were agreed according to R3-99503 with modifications. • Some minor editorial changes made.
1.1.0	July 1999	Same as v. 1.0.2 approved in RAN WG3 and raised to v. 1.1.0.

1.1.1.	July 1999	<p>Main updates made based on WG3 meeting #5 decisions:</p> <ul style="list-style-type: none"> • Description and definition of elementary procedure added according to R3-99727 with modifications. List of elementary procedures included. • As a result of R3-99727, <i>Iu Release Request</i> changed to an elementary procedure. Text proposed by the Editor. • Failure handling added to Relocation procedure based on R3-99746 with modifications. • <i>Relocation Cancel</i> elementary procedure added according to R3-99745 with modifications. • Bearer ID changed to RAB ID and NAS Binding ID added according to R3-99747. • User Plane Mode parameter added to <i>RAB Assignment</i> and Relocation procedures according to R3-99720. • The Cause parameter added and Transparent field changed to mandatory in RELOCATION REQUIRED and RELOCATION REQUEST messages according to R3-99678. • The parameters for <i>Location Reporting Control</i> and <i>Location Report</i> procedures were agreed according to R3-99748. • The message contents for the remaining procedures and parameter definitions added based on R3-99670 with modifications.
1.1.2	August 1999	'Cause' parameter removed from <i>Overload Control</i> procedure description. Minor editorial changes.
1.2.0	August 1999	Version 1.1.2 approved in WG3#6 and raised to v. 1.2.0.
1.2.1	September 1999	<p>Decisions from WG3#6 have been updated as follows:</p> <ul style="list-style-type: none"> • <i>RAB Assignment</i> procedure rewritten according to Tdoc R3-99A74 (=updated Tdoc R3-99942) with modifications. Type Class 3 of Elementary Procedure introduced. • <i>RAB Release Request</i> procedure added according to Tdoc R3-99A09. • List of RANAP functions added according to Tdoc R3-99A01 with modifications. • 'Transparent field' changed to 'Transparent container' according to Tdoc R3-99952. • A concept of handling relocation co-ordination in source and target RNC added according to Tdoc R3-99A10 with modifications. • Handling of the crossing of RESET messages was included as proposed in Tdoc R3-99909. • Editorial comments proposed in Tdoc R3-99940 included with modifications. • Definitions in Tdoc R3-99A60 added with modifications.

1.2.2	September 1999	<p>Some additional updates made to fullfil the agreements from WG3#6:</p> <ul style="list-style-type: none"> • The definition of Class 3 Elementary Procedure clarified. • The <i>Overload Control</i> and <i>Location Report</i> procedures have been updated according to the agreements in WG3#6. • The description of <i>Iu Release</i> and <i>Cipher Mode Control</i> procedures has been further updated to better reflect the decisions in WG3#6. • The possibility of RAB release to fail added also into the message contents of RAB ASSIGNMENT RESPONSE. • Some other minor editorial updates.
1.2.3	September 1999	<p>Editor's proposals according to WG3#6 agreements:</p> <ul style="list-style-type: none"> • Section 'Scope' has been rewritten. • Missing IE definitions have been proposed. • The order of describing procedures, message contents and IE definitions has been changed. • Proposed to replace 'signalling connection' by 'signalling bearer' in some instances. • Proposed to remove the paragraph regarding load sharing on the Iu PS interface in section 8.6.3 Relocation resource allocation.
1.3.0		Version 1.2.3 approved in WG3#7 and raised to v. 1.3.0
1.3.1		Updated based on the decisions in WG3#7. A summary of modifications can be found in Tdoc R3-99D24, which is the Chairman's report from Iu SWG meeting. Minor editorial changes are also included.
1.3.2	October 1999	Editor's proposal to harmonize the structure of presenting elementary procedures in section 8. Some clarifications have been added to the text (section 8). Minor editorial changes made.
1.4.0	October 1999	V 1.3.2 approved in WG3#8 and raised to v 1.4.0.
1.4.1	November 1999	<p>Updated according to decisions in WG3#8. Main changes are summarized as follows:</p> <ul style="list-style-type: none"> • New text has been inserted to sections 5 and 6. • Three new procedures added to section 8: SRNS Data Forwarding Initiation, SRNS Context Forwarding from Source RNC to CN and SRNS Data Forwarding from CN to Target RNC. • Tabular format presentation has been adopted for message contents and IE definitions in sections 9.1 and 9.2. • Value ranges for IEs have been defined. • Several other funtional and editorial updates have been included. Those are summarized in Iu SWG Chairman's report, Tdoc R3-99G10.

1.4.2	November 1999	<p>Main updates compared with v 1.4.1:</p> <ul style="list-style-type: none"> • RANAP procedures in section 8 have been reviewed by email discussions. No new functionality added. The revised procedures are presented without revision marks. • <i>Protocol Error Indication</i> IE has been added to those procedures where it was missing. • <i>Transmitted Data Volume</i> IE has been corrected to <i>Unsuccessfully Transmitted Data Volume</i>. • <i>RRC Container</i> IE has been corrected to <i>Target RNC to Source RNC Transparent Container</i> IE. • Some other minor corrections and editorial updates based on received comments on v 1.4.1.
1.4.3	December 1999	<p>Changes proposed by editor:</p> <ul style="list-style-type: none"> • Four remaining procedures have been converted to the same format as the others. • Agreements from ASN.1 Adhoc meeting to IE definition tables in section 9.2 have been updated. • ASN.1 modules resulted from the Adhoc meeting have been inserted in section 9.3. • Minor editorial changes made.
1.5.0	December 1999	Version 1.4.3 approved in WG3#9 and raised to v. 1.5.0.
1.5.1	December 1999	Updated according to decisions in WG3#9.
2.0.0	December 1999	Update according to comments from RAN WG3 #9 Iu SWG meeting
2.0.1	December 1999	Update according to comments from RAN WG3 #9.
2.1.0	December 1999	Approved by RAN WG3#9.
<p>Rapporteur for 3GPP UMTS 25.413 is:</p> <p>Jyrki Jussila Nokia Telecommunications Tel.: +358 9 5113 8436 Fax : +358 9 5113 8452 Email : jyrki.jussila@nokia.com</p>		
<p>This document is written in Microsoft Word version 7.0/96.</p>		