

TS 25.105 V3.0.0 (1999-10)

Technical Specification

**3rd Generation Partnership Project (3GPP);
Technical Specification Group (TSG) RAN WG4;
UTRA (BS) TDD; Radio transmission and Reception**



Reference

<Workitem> (<Shortfilename>.PDF)

Keywords

<keyword[, keyword]>

3GPP

Postal address

Office address

Internet

secretariat@3gpp.org
Individual copies of this deliverable
can be downloaded from
<http://www.3gpp.org>

Contents

Contents.....	3
Intellectual Property Rights	6
Foreword.....	6
1 Scope	7
2 References.....	7
3 Definitions, symbols and abbreviations	7
3.1 Definitions.....	7
3.2 Symbols.....	8
3.3 Abbreviations	8
4 General	9
4.1 Measurement uncertainty.....	9
4.2 Base station classes.....	9
5 Frequency bands and channel arrangement	10
5.1 General.....	10
5.2 Frequency bands	10
5.3 TX–RX frequency separation.....	10
5.4 Channel arrangement	10
5.4.1 Channel spacing.....	10
5.4.2 Channel raster.....	10
5.4.3 Channel number.....	10
6 Transmitter characteristics.....	12
6.1 General.....	12
6.2 Base station output power	12
6.2.1 Base station maximum output power	12
6.2.1.1 Minimum Requirement.....	12
6.3 Frequency stability.....	12
6.3.1 Minimum Requirement	12
6.4 Output power dynamics	12
6.4.1 Closed loop power control	12
6.4.2 Power control steps.....	12
6.4.2.1 Minimum Requirement.....	12
6.4.3 Power control dynamic range	13
6.4.3.1 Minimum Requirement.....	13
6.4.4 Minimum transmit power.....	13
6.4.4.1 Minimum Requirement.....	13
6.4.5 Total power dynamic range	13
6.4.5.1 Minimum Requirement.....	13
6.4.6 Power control cycles per second.....	13
6.4.6.1 Minimum Requirement.....	13
6.4.7 Perch channel power	14
6.5 Transmit OFF power	14
6.5.1 Minimum Requirement	14
6.6 Output RF spectrum emissions.....	14
6.6.1 Occupied bandwidth.....	14
6.6.2 Out of band emission.....	14
6.6.2.1 Spectrum emission mask.....	14
6.6.2.2 Adjacent Channel Leakage power Ratio (ACLR)	14
6.6.2.2.1 Minimum Requirement.....	14
6.6.2.3 Protection outside a licensee’s frequency block.....	14
6.6.2.3.1 Minimum requirement.....	14
6.6.3 Spurious emissions	15

6.6.3.1	Mandatory Requirements	15
6.6.3.1.1	Spurious emissions (Category A)	15
6.6.3.1.1.1	Minimum Requirement	15
6.6.3.1.2	Spurious emissions (Category B)	16
6.6.3.1.2.1	Minimum Requirement	16
6.6.3.2	Co-existence with GSM 900.....	16
6.6.3.2.1	Operation in the same geographic area	16
6.6.3.2.1.1	Minimum Requirement	16
6.6.3.2.2	Co-located base stations.....	16
6.6.3.2.2.1	Minimum Requirement	17
6.6.3.3	Co-existence with DCS 1800.....	17
6.6.3.3.1	Operation in the same geographic area	17
6.6.3.3.1.1	Minimum Requirement	17
6.6.3.3.2	Co-located basestations.....	17
6.6.3.3.2.1	Minimum Requirement	17
6.7	Transmit intermodulation	18
6.7.1.	Minimum Requirement	18
6.8	Transmit modulation	18
6.8.1	Transmit pulse shape filter	18
6.8.2	Modulation Accuracy	18
6.8.2.1	Minimum Requirement.....	18
6.8.3	Peak Code Domain Error.....	18
6.8.3.1	Minimum Requirement.....	18
7	Receiver characteristics	19
7.1	General.....	19
7.2	Reference sensitivity level.....	19
7.2.1	Minimum Requirement	19
7.2.2	Maximum Frequency Deviation for Receiver Performance	19
7.3	Dynamic range	19
7.4	Adjacent Channel Selectivity (ACS).....	19
7.4.1	Minimum Requirement	19
7.5	Blocking characteristics.....	20
7.6	Intermodulation characteristics.....	20
7.7	Spurious emissions	21
7.7.1	Minimum Requirement	21
7.8	Timing Advance (TA) Requirements.....	21
8	Performance requirement	22
8.1	General.....	22
8.2	Demodulation in static propagation conditions.....	22
8.2.1	Demodulation of DCH.....	22
8.2.1.1	Minimum requirement.....	22
8.2.2	Demodulation of RACH	23
8.2.2.1	Minimum requirement.....	23
8.3	Demodulation of DCH in multipath fading conditions	23
8.3.1	Multipath fading Case 1	23
8.3.1.1	Minimum requirement.....	23
8.3.2	Multipath fading Case 2	23
8.3.2.1	Minimum requirement.....	23
8.3.3	Multipath fading Case 3	24
8.3.3.1	Minimum requirement.....	24
8.4	Demodulation of RACH in multipath fading conditions	24
8.4.1	Multipath fading Case 1	24
8.4.1.1	Minimum requirement.....	24
8.5	BS synchronisation performance.....	24
8.5.1	Minimum Requirement	24
Annex A (normative): Measurement Channels.....		25
A.1	General.....	25

A.2	Reference measurement channel	25
A.2.1	UL reference measurement channel (12.2 kbps).....	25
A.2.2	UL reference measurement channel (64 kbps)	26
A.2.3	UL reference measurement channel (144 kbps).....	27
A.2.4	UL reference measurement channel (384 kbps).....	28
A.2.5	RACH reference measurement channel	29
A.2.5.1	RACH mapped to 1 code SF16.....	29
A.2.5.2	RACH mapped to 1 code SF8.....	30
Annex B (normative): Propagation conditions		31
B.1	Static propagation condition	31
B.2	Multi-path fading propagation conditions	31
Annex D (informative): Open items.....		32
History.....		33

Intellectual Property Rights

IPRs essential or potentially essential to the present document may have been declared to ETSI. The information pertaining to these essential IPRs, if any, is publicly available for **ETSI members and non-members**, and can be found in ETR 314: "*Intellectual Property Rights (IPRs); Essential, or potentially Essential, IPRs notified to ETSI in respect of ETSI standards*", which is available **free of charge** from the ETSI Secretariat. Latest updates are available on the ETSI Web server (<http://www.etsi.fr/ipr>).

Pursuant to the ETSI Interim IPR Policy, no investigation, including IPR searches, has been carried out by ETSI. No guarantee can be given as to the existence of other IPRs not referenced in ETR 314 (or the updates on <http://www.etsi.fr/ipr>) which are, or may be, or may become, essential to the present document.

Foreword

This Technical Specification has been produced by the 3GPP.

The contents of the present document are subject to continuing work within the TSG and may change following formal TSG approval. Should the TSG modify the contents of this TS, it will be re-released by the TSG with an identifying change of release date and an increase in version number as follows:

Version 3.y.z

where:

- x the first digit:
 - 1 presented to TSG for information;
 - 2 presented to TSG for approval;
 - 3 Indicates TSG approved document under change control.
- y the second digit is incremented for all changes of substance, i.e. technical enhancements, corrections, updates, etc.
- z the third digit is incremented when editorial only changes have been incorporated in the specification.

1 Scope

This document establishes the minimum RF characteristics of the TDD mode of UTRA.

2 References

The following documents contain provisions which, through reference in this text, constitute provisions of the present document.

- References are either specific (identified by date of publication, edition number, version number, etc.) or non-specific.
- For a specific reference, subsequent revisions do not apply.
- For a non-specific reference, the latest version applies.
- A non-specific reference to an ETS shall also be taken to refer to later versions published as an EN with the same number.

[1] ITU-R Recommendation SM.329-7 “Spurious emissions”

3 Definitions, symbols and abbreviations

3.1 Definitions

For the purposes of the present document, the definitions apply.

Power Setting -	The value of the control signal, which determines the desired transmitter, output Power. Typically, the power setting would be altered in response to power control commands
Maximum Power Setting -	The highest value of the Power control setting which can be used.
Maximum output Power	This refers to the measure of power when averaged over the transmit timeslot at the maximum power setting.
Peak Power -	The instantaneous power of the RF envelope which is not expected to be exceeded for [99.9%] of the time.
Maximum peak power -	The peak power observed when operating at a given maximum output power.
Average Power -	The average transmitter output power obtained over any specified time interval, including periods with no transmission. <i><Editors: This definition would be relevant when considering realistic deployment scenarios where the power control setting may vary. ></i>
Maximum average power	The average transmitter output power obtained over any specified time interval, including periods with no transmission, when the transmit time slots are at the maximum power setting. <i><Editors: The average power at the maximum power setting would also be consistent with defining a long term average power></i>
Zero distance -	Connected to the antenna connector of the BS using an interconnection of negligible delay

3.2 Symbols

For the purposes of the present document, the following symbols apply:

<symbol> <Explanation>

3.3 Abbreviations

For the purposes of the present document, the following abbreviations apply:

ACIR	Adjacent Channel Interference Ratio
ACLR	Adjacent Channel Leakage power Ratio
ACS	Adjacent Channel Selectivity
BER	Bit Error Rate
BS	Base Station
CW	Continuous wave (unmodulated signal)
DL	Down link (forward link)
EIRP	Effective Isotropic Radiated Power
FDD	Frequency Division Duplexing
FER	Frame Error Rate
PPM	Parts Per Million
RSSI	Received Signal Strength Indicator
SIR	Signal to Interference ratio
TDD	Time Division Duplexing
TPC	Transmit Power Control
UE	User Equipment
UL	Up link (reverse link)
UTRA	UMTS Terrestrial Radio Access

4 General

4.1 Measurement uncertainty

The requirements given in this specification are absolute. Compliance with the requirements is determined by comparing the measured value with the specified limit, without making allowance for measurement uncertainty.

4.2 Base station classes

The requirements in this specification apply to base station intended for general-purpose applications in co-ordinated network operation.

In the future further classes of base stations may be defined; the requirements for these may be different than for general-purpose applications.

5 Frequency bands and channel arrangement

5.1 General

The information presented in this section is based on a chip rate of 3.84 Mcps.

Note

1. Other chip rates may be considered in future releases.

5.2 Frequency bands

UTRA/TDD is designed to operate in the following bands;

- 1900 – 1920 MHz: Uplink and downlink transmission
2010 – 2025 MHz Uplink and downlink transmission
- * 1850 – 1910 MHz: Uplink and downlink transmission
1930 – 1990 MHz: Uplink and downlink transmission

Note: Appropriate adjustment is required for the parameters in the specified band

- * 1910 – 1930 MHz: Uplink and downlink transmission
Note: Appropriate adjustment is required for the parameters in the specified band

* Used in ITU Region 2

Additional allocations in ITU region 2 are FFS.

Deployment in other frequency bands is not precluded.

The co-existence of TDD and FDD in the same bands is still under study in WG4.

5.3 TX–RX frequency separation

No TX-RX frequency separation is required as Time Division Duplex (TDD) is employed. Each TDMA frame consists of 15 timeslots where each timeslot can be allocated to either transmit or receive.

5.4 Channel arrangement

5.4.1 Channel spacing

The nominal channel spacing is 5 MHz, but this can be adjusted to optimise performance in a particular deployment scenario.

5.4.2 Channel raster

The channel raster is 200 kHz, which means that the carrier frequency must be a multiple of 200 kHz.

5.4.3 Channel number

The carrier frequency is designated by the UTRA absolute radio frequency channel number (UARFCN). The value of the UARFCN in the IMT2000 band is defined as follows:

Lower IMT 2000 band:

$$N_t = 5 * (F - 1885.2)$$

$$1885.2 \leq F \leq 2024.8$$

where F is the carrier frequency in MHz

6 Transmitter characteristics

6.1 General

Unless detailed the transmitter characteristic are specified at the antenna connector.

6.2 Base station output power

Output power, P_{out} , of the base station is the mean power of one carrier delivered to a load with resistance equal to the nominal load impedance of the transmitter during one slot.

6.2.1 Base station maximum output power

Maximum output power, P_{max} , of the base station is the mean power level per carrier that the manufacturers has declared to be available at the antenna connector.

6.2.1.1 Minimum Requirement

In normal conditions, the base station maximum output power shall remain within +2 dB and -2 dB of the manufacturer's rated power.

In extreme conditions, the Base station maximum output power shall remain within +2.5 dB and -2.5 dB of the manufacturer's rated power.

6.3 Frequency stability

Frequency stability is ability of the BS to transmit at the assigned carrier frequency.

6.3.1 Minimum Requirement

The modulated carrier frequency of the BS shall be accurate to within ± 0.05 PPM for RF frequency generation.

6.4 Output power dynamics

Power control is used to limit the interference level. The transmitter uses a quality-based power control on the downlink.

6.4.1 Closed loop power control

Closed loop power control is the ability of the BS transmitter to adjust its output power in response to the UL received signal.

For closed loop correction on the Downlink Channel (with respect to the open loop estimate), the base station adjust its mean output power level in response to each valid power control bit received from the UE on the Uplink Traffic Channel.

6.4.2 Power control steps

The power control step is the step change in the DL transmitter output power in response to a TPC message from the UE.

6.4.2.1 Minimum Requirement

Down link (DL) 1, 2, 3 dB

The tolerance of the transmitter output power and the greatest average rate of change in mean power due to the power control step shall be within the range shown in Table 6.1.

Table 6.1: power control step size tolerance

Step size	Tolerance	Range of average rate of change in mean power per 10 steps	
		minimum	maximum
1dB	+/-0.5dB	+/-8dB	+/-12dB
2dB	+/-0.75dB	+/-16dB	+/-24dB
3dB	+/-1dB	+/-24dB	+/-36dB

6.4.3 Power control dynamic range

The power control dynamic range is the difference between the maximum and the minimum transmit output power for a specified reference condition

6.4.3.1 Minimum Requirement

Down link (DL) power control dynamic range 30 dB

6.4.4 Minimum transmit power

The minimum controlled output power of the BS is when the power control setting is set to a minimum value. This is when the power control indicates a minimum transmit output power is required.

6.4.4.1 Minimum Requirement

Down link (DL) minimum transmit power is set to: Maximum output power – 30dB

6.4.5 Total power dynamic range

The power control dynamic range is difference between the maximum and the minimum transmit output power for a specified reference condition

6.4.5.1 Minimum Requirement

Down link (DL) total dynamic range 30 dB

<This requirement is redundant, since 6.4.4 defines the same dynamic range by a minimum transmit power.>

6.4.6 Power control cycles per second

The rate of change for DL transmitter power control step.

6.4.6.1 Minimum Requirement

The rate of change for the DL transmitter power control step is as follows: 100 – 800 Hz.

The minimum rate of [100] Hz is to ensure that every frame is power controlled. The maximum rate may differ for open and closed loop power control due to frame configuration.

6.4.7 Perch channel power

<The name and the use of the common control channel may need to be adapted, subject to WG1 definition.>

6.5 Transmit OFF power

The transmit OFF power state is when the BS does not transmit. This parameter is defined as maximum output transmit power within the channel bandwidth when the transmitter is OFF.

6.5.1 Minimum Requirement

The requirement of transmitOFF power shall be better than -33dBm measured with a filter that has a Root Raised Cosine (RRC) filter response with a roll off $\alpha=0.22$ and a bandwidth equal to the chip rate.

6.6 Output RF spectrum emissions

6.6.1 Occupied bandwidth

Occupied bandwidth is a measure of the bandwidth containing 99% of the total integrated power for transmitted spectrum and is centered on the assigned channel frequency. The occupied channel bandwidth is less than 5 MHz based on a chip rate of 3.84 Mcps.

6.6.2 Out of band emission

Out of band emissions are unwanted emissions immediately outside the [channel] bandwidth resulting from the modulation process and non-linearity in the transmitter but excluding spurious emissions. This out of band emission limit is specified in terms of a spectrum emission mask and adjacent channel power ratio for the transmitter.

6.6.2.1 Spectrum emission mask

6.6.2.2 Adjacent Channel Leakage power Ratio (ACLR)

Adjacent Channel Leakage power Ratio (ACLR) is the ratio of the transmitted power to the power measured after a receive filter in the adjacent channel(s). Both the transmitted and the received power are measured through a matched filter (Root Raised Cosine and roll-off 0.22) with a noise power bandwidth equal to the chip rate.

6.6.2.2.1 Minimum Requirement

The ACLR shall be better than the value specified in Table 6.2.

Table 6.2: BS ACLR

BS adjacent channel offset	ACLR limit
± 5 MHz	[45] dB
± 10 MHz	[55] dB

6.6.2.3 Protection outside a licensee's frequency block

This requirement is applicable if protection is required outside a licensee's defined frequency block.

6.6.2.3.1 Minimum requirement

This requirement applies for frequencies outside the licensee's frequency block, up to an offset of 12.5MHz from a carrier frequency.

The power of any emission shall be attenuated below the transmit power (P) by at least $43 + 10 \log (P)$ dB.

Compliance with this provision is based on the use of measurement instrumentation employing a resolution bandwidth of 1MHz or greater. However, in the 1MHz bands immediately outside and adjacent to the frequency block a resolution bandwidth of at least one percent of the fundamental emission of the transmitter may be employed. The emission bandwidth is defined as the width of the signal between two points, one below the carrier centre frequency and one above the carrier centre frequency, outside of which all emissions are attenuated at least 26dB below the transmitter power.

When measuring the emission limits, the nominal carrier frequency shall be adjusted as close to the licensee's frequency block edges, both upper and lower, as the design permits.

The measurements of emission power shall be mean power.

6.6.3 Spurious emissions

Spurious emissions are emissions which are caused by unwanted transmitter effects such as harmonics emission, parasitic emission, intermodulation products and frequency conversion products, but exclude out of band emissions. This is measured at the base station RF output port.

Unless otherwise stated, all requirements are measured as mean power.

6.6.3.1 Mandatory Requirements

The requirements of either subclause 6.6.3.1.1 or subclause 6.6.3.1.2 shall apply whatever the type of transmitter considered (single carrier or multi-carrier). It applies for all transmission modes foreseen by the manufacturer's.

Either requirement applies at frequencies within the specified frequency ranges which are more than 12.5MHz under the first carrier frequency used or more than 12.5 MHz above the last carrier frequency used.

6.6.3.1.1 Spurious emissions (Category A)

The following requirements shall be met in cases where Category A limits for spurious emissions, as defined in ITU-R Recommendation SM.329-7 [1], are applied.

6.6.3.1.1.1 Minimum Requirement

The power of any spurious emission shall not exceed:

Table 6.3: BS Mandatory spurious emissions limits, Category A

Band	Minimum requirement	Measurement Bandwidth	Note
9kHz – 150kHz	-13 dBm	1 kHz	Bandwidth as in ITU SM.329-7, s4.1
150kHz – 30MHz		10 kHz	Bandwidth as in ITU SM.329-7, s4.1
30MHz – 1GHz		100 kHz	Bandwidth as in ITU SM.329-7, s4.1
1GHz – 12.75 GHz		1 MHz	Upper frequency as in ITU SM.329-7, s2.6

P = Mean power (W) where $P < 500W$

6.6.3.1.2 Spurious emissions (Category B)

The following requirements shall be met in cases where Category B limits for spurious emissions, as defined in ITU-R Recommendation SM.329-7 [1], are applied.

6.6.3.1.2.1 Minimum Requirement

The power of any spurious emission shall not exceed:

Table 6.4: BS Mandatory spurious emissions limits, Category B

Band	Maximum Level	Measurement Bandwidth	Note
9kHz – 150kHz	-36dBm	1 kHz	Bandwidth as in ITU SM.329-7, s4.1
150kHz – 30MHz	- 36 dBm	10 kHz	Bandwidth as in ITU SM.329-7, s4.1
30MHz – 1GHz	-36 dBm	100 kHz	Bandwidth as in ITU SM.329-7, s4.1
1GHz – 12.75 GHz	-30 dBm	1 MHz	Upper frequency as in ITU SM.329-7, s2.6

6.6.3.2 Co-existence with GSM 900

6.6.3.2.1 Operation in the same geographic area

This requirement may be applied for the protection of GSM 900 MS in geographic areas in which both GSM 900 and UTRA are deployed.

[This requirement assumes the scenario described in 25.942.] For different scenarios, the manufacturer may declare a different requirement.

6.6.3.2.1.1 Minimum Requirement

The power of any spurious emission shall not exceed:

Table 6.5: BS Spurious emissions limits for BS in geographic coverage area of GSM 900

Band	Maximum Level	Measurement Bandwidth	Note
921 – 960MHz	-47 dBm	100 kHz	

6.6.3.2.2 Co-located base stations

This requirement may be applied for the protection of GSM 900 BTS receivers when GSM 900 BTS and UTRA BS are co-located.

[This requirement assumes the scenario described in 25.942.] For different scenarios, the manufacturer may declare a different requirement.

6.6.3.2.2.1 Minimum Requirement

The power of any spurious emission shall not exceed:

Table 6.6: BS Spurious emissions limits for protection of the BS receiver

Band	Maximum Level	Measurement Bandwidth	Note
921 – 960MHz	–[98]dBm	100 kHz	

6.6.3.3 Co-existence with DCS 1800

6.6.3.3.1 Operation in the same geographic area

This requirement may be applied for the protection of DCS 1800 MS in geographic areas in which both DCS 1800 and UTRA are deployed.

[This requirement assumes the scenario described in 25.942.] For different scenarios, the manufacturer may declare a different requirement.

6.6.3.3.1.1 Minimum Requirement

The power of any spurious emission shall not exceed:

Table 6.7: BS Spurious emissions limits for BS in geographic coverage area of DCS 1800

Band	Maximum Level	Measurement Bandwidth	Note
1805 – 1880MHz	-57 dBm	100 kHz	

6.6.3.3.2 Co-located basestations

This requirement may be applied for the protection of DCS 1800 BTS receivers when DCS 1800 BTS and UTRA BS are co-located.

[This requirement assumes the scenario described in 25.942.] For different scenarios, the manufacturer may declare a different requirement.

6.6.3.3.2.1 Minimum Requirement

The power of any spurious emission shall not exceed:

Table 6.8: BS Spurious emissions limits for BS co-located with DCS 1800 BTS

Band	Maximum Level	Measurement Bandwidth	Note
1710 – 1785 MHz	–[98]dBm	100 kHz	

6.7 Transmit intermodulation

The transmit intermodulation performance is a measure of the capability of the transmitter to inhibit the generation of signals in its non linear elements caused by presence of the wanted signal and an interfering signal reaching the transmitter via the antenna.

The transmit intermodulation level is the power of the intermodulation products when a CDMA modulated interference signal is injected into the antenna connector at a level of 30 dB lower than that of the subject signal. The frequency of the interference signal shall be ± 5 MHz, ± 10 MHz and ± 15 MHz offset from the subject signal.

6.7.1. Minimum Requirement

The Transmit intermodulation level shall not exceed the out of band or the spurious emission requirements of section 6.6.2 and 6.6.3.

6.8 Transmit modulation

6.8.1 Transmit pulse shape filter

The transmit pulse-shaping filter is a root-raised cosine (RRC) with roll-off $\alpha = 0.22$ in the frequency domain. The impulse response of the chip impulse filter $RC_0(t)$ is

$$RC_0(t) = \frac{\sin\left(\frac{p}{T_c}t(1-a)\right) + 4a\frac{t}{T_c}\cos\left(\frac{p}{T_c}t(1+a)\right)}{\frac{p}{T_c}\left(1 - \left(4a\frac{t}{T_c}\right)^2\right)}$$

Where the roll-off factor $\alpha = 0.22$ and the chip duration: $T_c = \frac{1}{\text{chiprate}} \approx 0.26042 \text{ms}$

6.8.2 Modulation Accuracy

The modulation accuracy is a measure of the difference between the measured waveform and the theoretical modulated waveform (the error vector). It is the square root of the ratio of the mean error vector power to the mean reference signal power expressed as %. The measurement interval is one timeslot.

6.8.2.1 Minimum Requirement

The Modulation accuracy shall not be worse than 12.5 %.

6.8.3 Peak Code Domain Error

The code domain error is computed by projecting the error vector power onto the code domain at the maximum spreading factor. The error power for each code is defined as the ratio to the mean power of the reference waveform expressed in dB. And the Peak Code Domain Error is defined as the maximum value for Code Domain Error. The measurement interval is one timeslot.

6.8.3.1 Minimum Requirement

The peak code domain error shall not exceed -28 dB.

7 Receiver characteristics

7.1 General

Unless detailed the receiver characteristic are specified at each antenna connector of the BS.

7.2 Reference sensitivity level

The reference sensitivity is the minimum receiver input power measured at the antenna connector at which the FER/BER does not exceed the specific value indicated in section 7.2.1. The signal power is equally applied to each antenna connector for diversity.

7.2.1 Minimum Requirement

For the measurement channel specified in Annex A, the reference sensitivity level and performance of the BS shall be as specified in table 7.1 below.

Table 7.1: BS reference sensitivity levels

Data rate	BS reference sensitivity level (dBm)	FER/BER
12.2 kbps	-110 dBm	BER shall not exceed 0.001

7.2.2 Maximum Frequency Deviation for Receiver Performance

The need for such a requirement is for further study.

7.3 Dynamic range

The receiver dynamic range is the input power range at each BS antenna connector over which the [FER/BER] does not exceed a specific rate.

The static [BER/BER] reference performance as specified in clause 7.3.1 should be met over a receiver input range of [30] dB above the specified reference sensitivity level for [channel type ffs].

7.4 Adjacent Channel Selectivity (ACS)

Adjacent channel selectivity (ACS) is a measure of the receiver ability to receive a wanted signal at its assigned channel frequency in the presence of an adjacent channel signal at a given frequency offset from the center frequency of the assigned channel. ACS is the ratio of the receiver filter attenuation on the assigned channel frequency to the receive filter attenuation on the adjacent channel(s).

7.4.1 Minimum Requirement

The BER shall not exceed 0.001 for the parameters specified in table 7.2.

Table 7.2 : Adjacent channel selectivity

Parameter	Level	Unit
Data rate	12.2	kbps
Wanted signal	[]	dBm
Interfering signal	[]	dBm

Fuw (Modulated)	5	MHz
-----------------	---	-----

7.5 Blocking characteristics

The blocking characteristics is a measure of the receiver ability to receive a wanted signal at its assigned channel frequency in the presence of an unwanted interferer on frequencies other than those of the spurious response or the adjacent channels. The blocking performance shall apply at all frequencies as specified in the table below.

The static reference performance as specified in clause 7.2.1 should be met with a wanted and an interfering signal coupled to BS antenna input using the following parameters.

Table 7.3 : Blocking requirements

Center Frequency of Interfering Signal	Interfering Signal Level	Wanted Signal Level	Minimum Offset of Interfering Signal	Type of Interfering Signal
1900 – 1920 MHz, 2010 – 2025 MHz	-40 dBm	<REFSENS> + 6 dB	10 MHz	WCDMA signal with one code
1880 – 1900 MHz, 1990 – 2010 MHz, 2025 – 2045 MHz	-40 dBm	<REFSENS> + 6 dB	10 MHz	WCDMA signal with one code
1920 – 1980 MHz	-40 dBm	<REFSENS> + 6 dB	10 MHz	WCDMA signal with one code
<1880, 1980 – 1990 MHz, > 2045 MHz	-15 dBm	<REFSENS> + 6 dB	—	CW carrier

7.6 Intermodulation characteristics

Third and higher order mixing of the two interfering RF signals can produce an interfering signal in the band of the desired channel. Intermodulation response rejection is a measure of the capability of the receiver to receive a wanted signal on its assigned channel frequency in the presence of two or more interfering signals which have a specific frequency relationship to the wanted signal.

The static reference performance as specified in clause 7.2.1 should be met when the following signals are coupled to BS antenna input.

- ❑ A wanted signal at the assigned channel frequency, 6 dB above the static reference level.
- ❑ Two interfering signals with the following parameters.

Table 12 : Intermodulation requirement

Interfering Signal Level	Offset	Type of Interfering Signal
- 48 dBm	10 MHz	CW signal
- 48 dBm	20 MHz	WCDMA signal with one code

7.7 Spurious emissions

The spurious emissions power is the power of emissions generated or amplified in a receiver that appear at the BS receiver antenna connector.

7.7.1 Minimum Requirement

The spurious emission shall be:

- (a) Less than [-78] dBm/3.84 MHz at the BS receiver antenna connector, for frequencies within the BS receive band.
- (b) Less than [-57] dBm/100 kHz at the BS receiver antenna connector, for frequencies bands from 9kHz to 1GHz.
- (c) Less than [-47] dBm/100 kHz at the BS receiver antenna connector, for frequencies bands from 1GHz to 12.75GHz.

7.8 Timing Advance (TA) Requirements

The conditions under the requirements which must be met shall be 3dB below reference sensitivity level in section 7.2.

- On request the BS shall measure the delay of the received signal relative to the expected signal from an UE at zero distance under static channel conditions (see Annex B). This delay, called the timing advance, shall be rounded to the nearest value corresponding to 4 chips period. The delay shall be assessed in such a way that the measurement error (due to noise and interference) is less than 2 chips periods for stationary UE.

8 Performance requirement

8.1 General

Performance requirements for the BS are specified for the measurement channels defined in Annex A and the propagation conditions in Annex B. The requirements only apply to those measurement channels that are supported by the base station.

The requirements only apply to a base station with dual receiver antenna diversity. The required E_b/N_0 shall be applied separately at each antenna port.

Table 8.1: Summary of Base Station performance targets

Physical channel	Measurement channel	Static	Multi-path Case 1	Multi-path Case 2	Multi-path Case 3
		Performance metric			
DCH	12.2 kbps				
	64 kbps				
	144 kbps				
	384 kbps				
	2048 kbps				-
RACH					

8.2 Demodulation in static propagation conditions

8.2.1 Demodulation of DCH

The performance requirement of DCH in static propagation conditions is determined by the maximum Block Error Rate (BLER) allowed when the receiver input signal is at a specified E_b/N_0 limit. The BLER is calculated for each of the measurement channels supported by the base station.

8.2.1.1 Minimum requirement

The BLER should not exceed the limit for the E_b/N_0 specified in Table 8.2.

Table 8.2: Performance requirements in AWGN channel.

Measurement channel	Required E_b/N_0	Required E_b/N_0
12.2 kbps		
64 kbps		
144 kbps		
384 kbps		
2048 kbps		

8.2.2 Demodulation of RACH

8.2.2.1 Minimum requirement

8.3 Demodulation of DCH in multipath fading conditions

8.3.1 Multipath fading Case 1

The performance requirement of DCH in multipath fading Case 1 is determined by the maximum Block Error Rate (BLER) allowed when the receiver input signal is at a specified E_b/N_0 limit. The BLER is calculated for each of the measurement channels supported by the base station.

8.3.1.1 Minimum requirement

The BLER should not exceed the limit for the E_b/N_0 specified in Table 8.3.

Table 8.3: Performance requirements in multipath Case 1 channel.

Measurement channel	Required E_b/N_0	Required E_b/N_0
12.2 kbps		
64 kbps		
144 kbps		
384 kbps		
2048 kbps		

8.3.2 Multipath fading Case 2

The performance requirement of DCH in multipath fading Case 2 is determined by the maximum Block Error Rate (BLER) allowed when the receiver input signal is at a specified E_b/N_0 limit. The BLER is calculated for each of the measurement channels supported by the base station.

8.3.2.1 Minimum requirement

The BLER should not exceed the limit for the E_b/N_0 specified in Table 8.4.

Table 8.4: Performance requirements in multipath Case 2 channel.

Measurement channel	Required E_b/N_0 BLER < 10^{-1}	Required E_b/N_0 BLER < 10^{-2}
12.2 kbps	n.a.	
64 kbps		
144 kbps		
384 kbps		

8.3.3 Multipath fading Case 3

The performance requirement of DCH in multipath fading Case 3 is determined by the maximum Block Error Rate (BLER) allowed when the receiver input signal is at a specified E_b/N_0 limit. The BLER is calculated for each of the measurement channels supported by the base station.

8.3.3.1 Minimum requirement

The BLER should not exceed the limit for the E_b/N_0 specified in Table 8.5.

Table 8.5: Performance requirements in multipath Case 3 channel.

Measurement channel	Required E_b/N_0	Required E_b/N_0	Required E_b/N_0
12.2 kbps	n.a.		
64 kbps			
144 kbps			
384 kbps			

8.4 Demodulation of RACH in multipath fading conditions

8.4.1 Multipath fading Case 1

8.4.1.1 Minimum requirement

8.5 BS synchronisation performance

8.5.1 Minimum Requirement

The timing error of BSs synchronised to each other shall be less than [5 μ s].

Annex A (normative): Measurement Channels

A.1 General

A.2 Reference measurement channel

A.2.1 UL reference measurement channel (12.2 kbps)

Parameter	
Information data rate	12.2 kbps
RU's allocated	2 RU
Midamble	512 chips
Interleaving	20 ms
Power control	2 Bit/user
TFCI	16 Bit/user
Inband signalling DCCH	2 kbps
Puncturing level at Code rate 1/3 : DCH / DCCH	5% / 0%

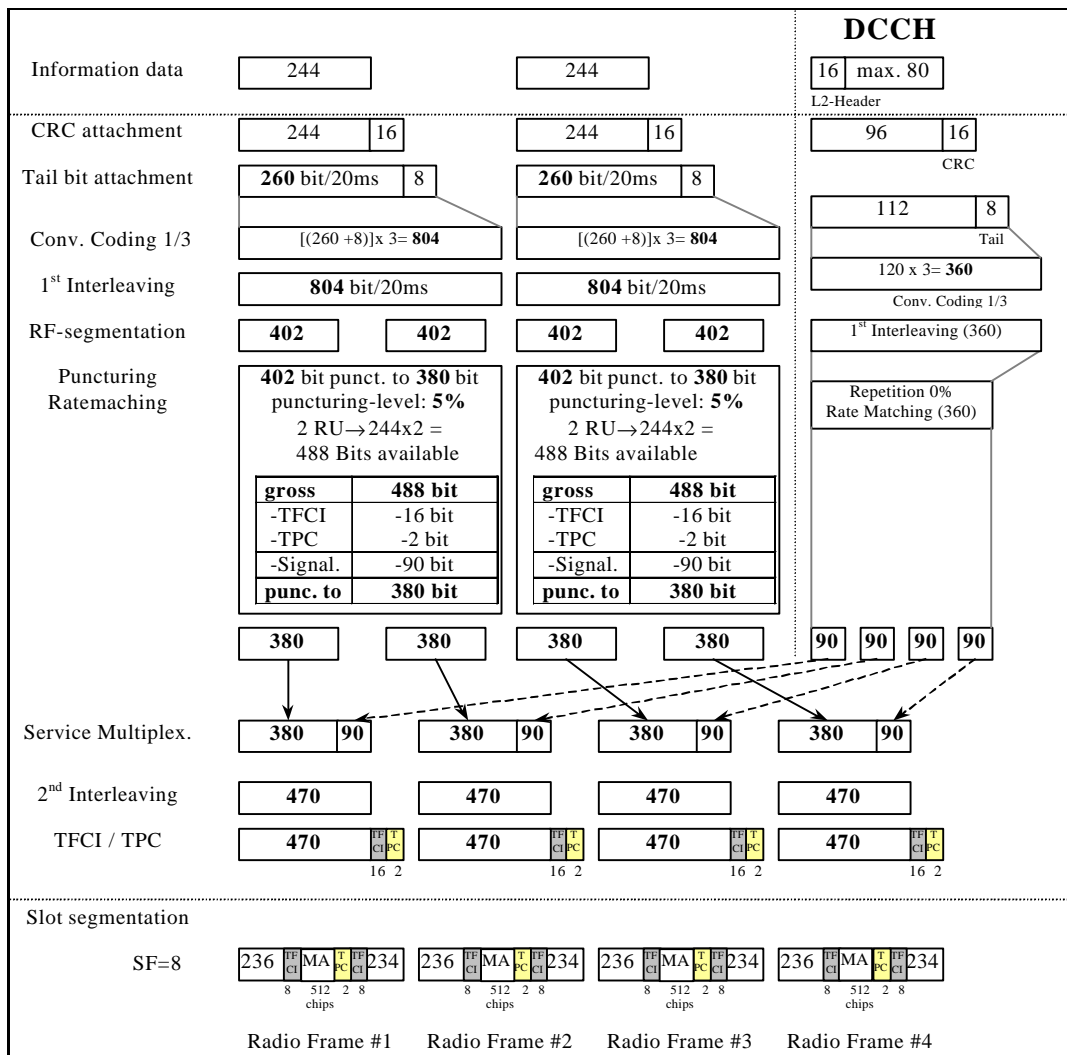

A.2.2 UL reference measurement channel (64 kbps)

Parameter	
Information data rate	64 kbps
RU's allocated	1 SF4 + 1 SF16 = 5RU
Midamble	512 chips
Interleaving	20 ms
Power control	2 Bit/user
TFCI	16 Bit/user
Inband signalling DCCH	2 kbps
Puncturing level at Code rate : 1/3 DCH / 1/2 DCCH	41.2% / 10%

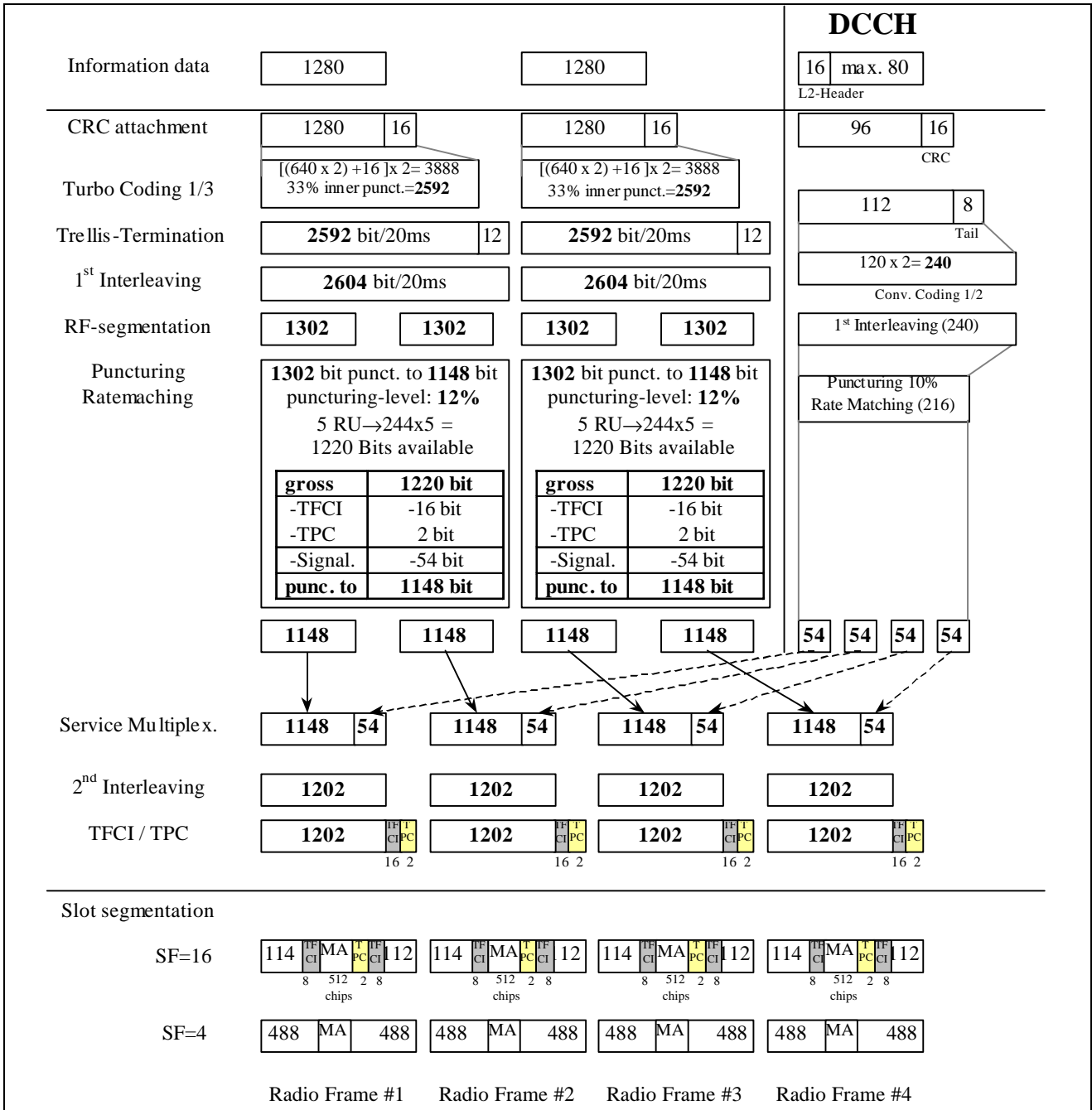

A.2.3 UL reference measurement channel (144 kbps)

Parameter	
Information data rate	144 kbps
RU's allocated	1 SF2 + 1 SF16 = 9RU
Midamble	256 chips
Interleaving	20 ms
Power control	2 Bit/user
TFCI	16 Bit/user
Inband signalling DCCH	2 kbps
Puncturing level at Code rate : 1/3 DCH / 1/2 DCCH	44.4% / 16.6%

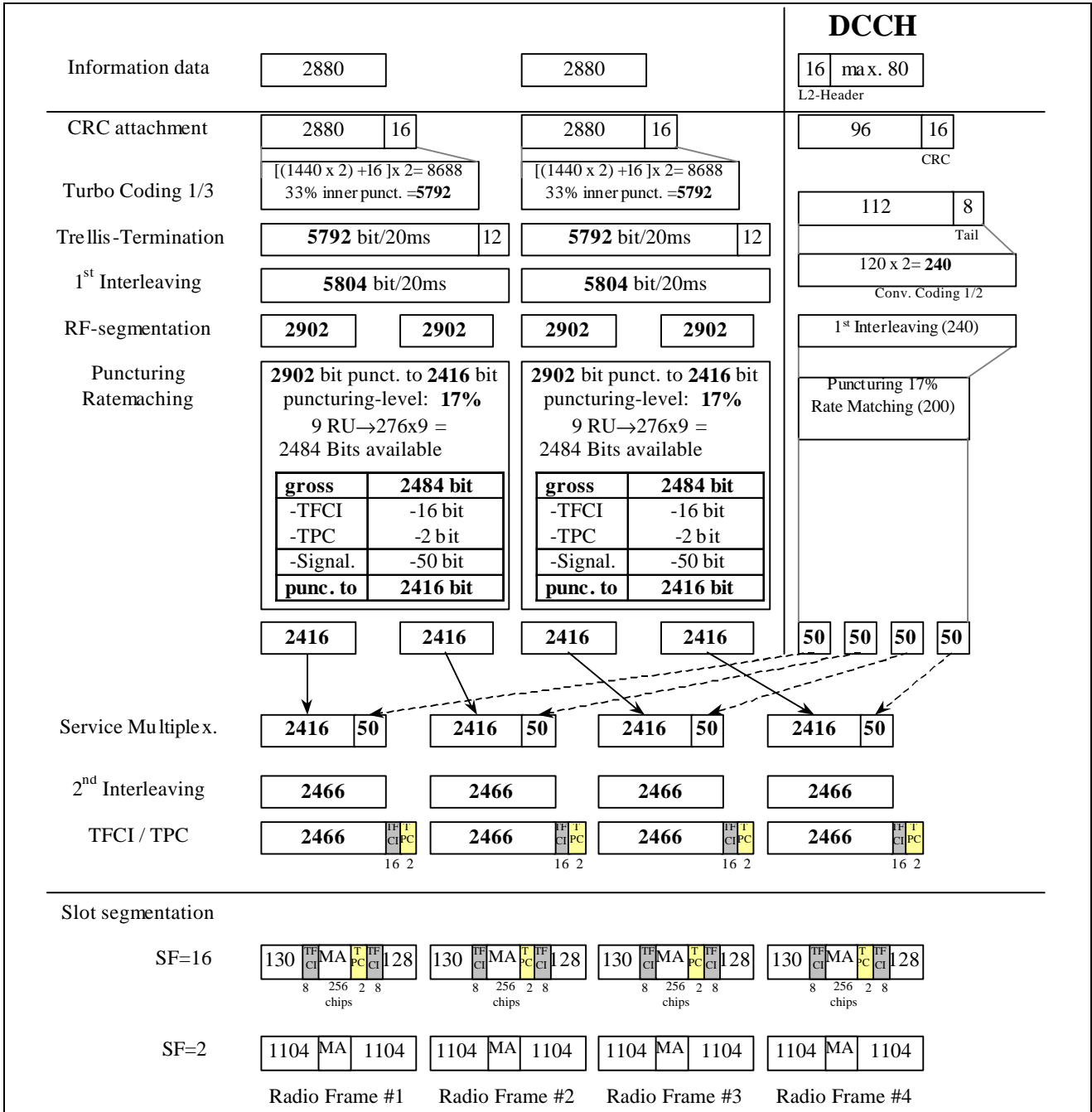

A.2.4 UL reference measurement channel (384 kbps)

Parameter	
Information data rate	384 kbps
RU's allocated	8*3TS = 24RU
Midamble	256 chips
Interleaving	20 ms
Power control	2 Bit/user
TFCI	16 Bit/user
Inband signalling DCCH	2 kbps
Puncturing level at Code rate : 1/3 DCH / 1/2 DCCH	43.4% / 15.3%

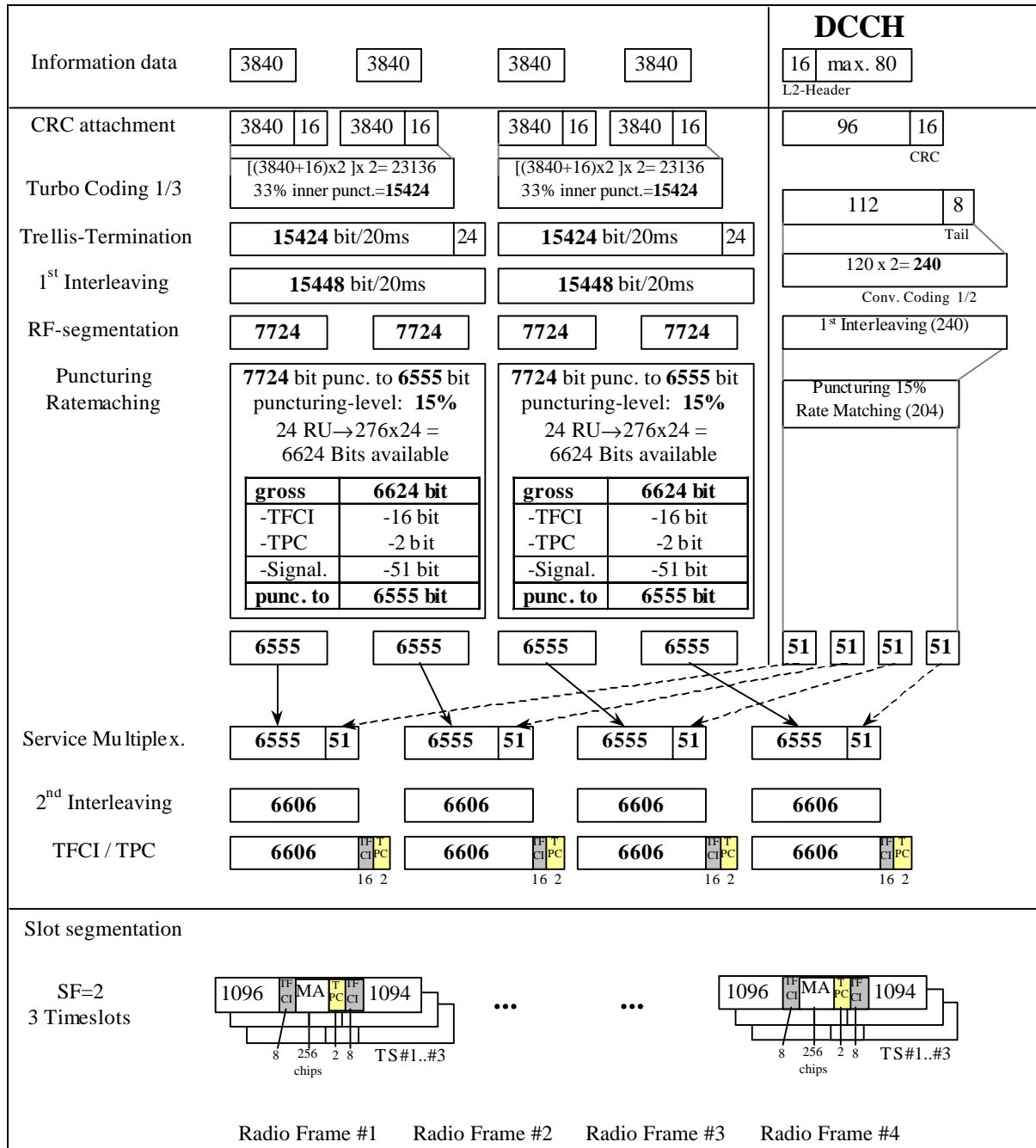

A.2.5 RACH reference measurement channel

Parameter	
Information data rate e.g. 2 TBs ($B_{RACH}=2$):	
SF16:	
0% puncturing rate at CR=1/2	46 bits per frame and TB
10% puncturing rate at CR=1/2	53 bits per frame and TB
$N_{RACH} = \frac{232 + N_{RM} - 8}{B_{RACH}} - 8$	
SF8:	
0% puncturing rate at CR=1/2	96 bits per frame and TB
10% puncturing rate at CR=1/2	109 bits per frame and TB
$N_{RACH} = \frac{464 + N_{RM} - 8}{B_{RACH}} - 16$	
RU's allocated	1 RU
Midamble	512 chips
Power control	0 bit
TFCI	0 bit

N_{RACH} = number of bits per TB

B_{RACH} = number of TBs

A.2.5.1 RACH mapped to 1 code SF16

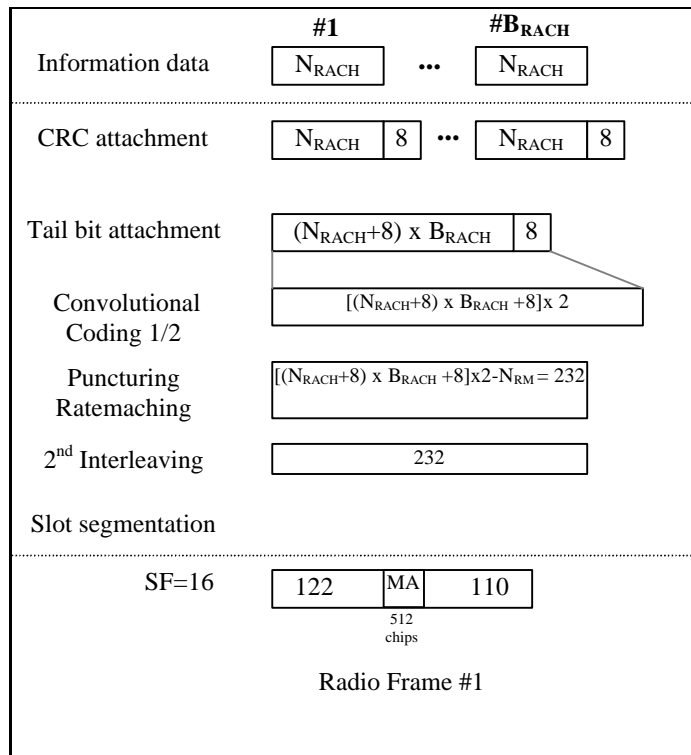

A.2.5.2 RACH mapped to 1 code SF8

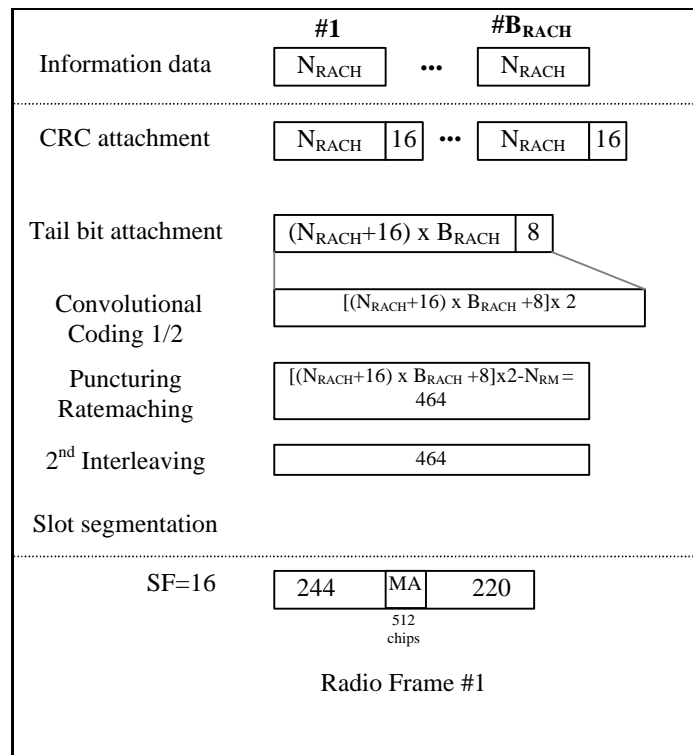

Annex B (normative): Propagation conditions

B.1 Static propagation condition

The propagation for the static performance measurement is an Additive White Gaussian Noise (AWGN) environment. No fading and multi-paths exist for this propagation model.

B.2 Multi-path fading propagation conditions

Table B1 shows propagation conditions that are used for the performance measurements in multi-path fading environment. All taps have classical Doppler spectrum.

Table B1: Propagation Conditions for Multi path Fading Environments

Case 1, speed 3km/h		Case 2, speed 3 km/h		Case 3, 120 km/h	
Relative Delay [ns]	Average Power [dB]	Relative Delay [ns]	Average Power [dB]	Relative Delay [ns]	Average Power [dB]
0	0	0	0	0	0
976	-10	976	0	260	-3
		20000	0	521	-6
				781	-9

Annex C (informative): Open items

Section number	Section description	Status
3	Definitions, symbols and abbreviations	Update needed
6.3	Frequency stability	Should there also be an accuracy requirement on the clock rate ? Alternatives are to either tie the clock rate to the frequency accuracy or to have a separate clock rate requirement.
6.4.3	Power control dynamic range	Redundant requirement included. The need for this parameter to be specified should be confirmed.
6.4.6	Power control cycles per second	Adaptation to 15 slots per frame needed, depending on WG1 specification, requirement needed ?
6.4.7	Perch channel power	Requirement for reference power in the cell is TBD.
6.6.2.1	Spectrum mask	Not included
6.6.2.2	ACLR	Values in square brackets
6.6.3.2.2	Co-existence with GSM 900; co-located base stations	Scenario calculations should be performed to confirm the requirement, currently [-98] dB.
6.6.3.3.2	Co-existence with GSM 1800; co-located base stations	Scenario calculations should be performed to confirm the requirement, currently [-98] dB.
7.3	Dynamic Range	Value in square brackets
7.4	ACS	Requirement is TBD.
7.8	Spurious Emissions	Values in square brackets
8	Performance Requirement	Values are TBD. Requirement for BS without dual receiver diversity is ffs.

History

Document history		
V0.0.1	1999-02-19	Document created based on S4.01B v0.0.2 “UTRA (BS) FDD, radio transmission and reception”
V0.0.2	1999-02-25	Editorial update after WG4#2 for distribution on the e-mail reflector.
V1.0.0	1999-03-02	Version presented to TSG RAN for information (identical to version 0.0.2)
V1.0.1	1999-04-13	Update according to decisions in TSG RAN WG4#3 in Tokyo, Japan, sent to WG4 e-mail reflector for comments
TS 25.105 V1.0.0	1999-04-22	Noted by TSG-RAN as TS 25.105 V1.0.0
V1.1.0	1999-06-11	Incorporation of agreed changes from WG4#4 Meeting in Kista.
V1.2.0	1999-07-07	Incorporation of agreed changes from WG4#5 Meeting in Miami.
V1.3.0	1999-08-06	Incorporation of agreed changes from WG4#6 Meeting in Edinburgh.
V2.0.0	1999-09-24	Incorporation of agreed changes from WG4#7 Meeting in Makuhari – Tokyo.
V2.1.0	1999-10-04	Update after the TSG RAN WG4 AH01 simulation meeting in Noordwijkerhout. Sent to the reflector for comments in advance of TSG RAN#5.
V3.0.0	1999-10-07	Approved by TSG-RAN#5
<p>Editor</p> <p>Meik Kottkamp</p> <p>Siemens AG</p> <p>Tel: +49 89 722 36223</p> <p>Fax: +49 89 722 24450</p> <p>E-Mail: meik.kottkamp@icn.siemens.de</p> <p>This document is written in Microsoft Word 7.0</p>		