

# TS 25.141 V24.0.04 (1999-098)

*Technical Specification*

**3<sup>rd</sup> Generation Partnership Project (3GPP);  
Technical Specification Group (TSG)  
Radio Access Network (RAN);  
Working Group 4 (WG4);  
Base station conformance testing (FDD)**



Reference

---

<Workitem>  
(<Shortfilename>.PDF)

Keywords

---

<keyword[, keyword]>

**3GPP**

Postal address

---

Office address

---

Internet

---

secretariat@3gpp.org  
Individual copies of this deliverable  
can be downloaded from  
<http://www.3gpp.org>

---

**Copyright Notification**

---

No part may be reproduced except as authorized by written permission.  
The copyright and the foregoing restriction extend to reproduction in all media.

© 3GPP 1999.  
All rights reserved.

---

# Contents

<b>Contents .....</b>	<b>ii</b>
<b>Intellectual Property Rights.....</b>	<b>1</b>
<b>Foreword .....</b>	<b>1</b>
<b>1 Scope .....</b>	<b>1</b>
<b>2 References .....</b>	<b>1</b>
<b>3 Definitions and abbreviations.....</b>	<b>2</b>
<b>3.1 Definitions.....</b>	<b>2</b>
<b>3.2 Symbols.....</b>	<b>2</b>
<b>3.3 Abbreviations.....</b>	<b>3</b>
<b>3.4 Radio Frequency bands.....</b>	<b>5</b>
3.4.1 Frequency bands .....	5
<b>4 General test conditions and declarations .....</b>	<b>6</b>
<b>4.1 Acceptable uncertainty of measurement equipment .....</b>	<b>6</b>
<b>4.2 Interpretation of measurement results .....</b>	<b>6</b>
<b>4.3 Output power and determination of power class .....</b>	<b>7</b>
<b>4.4 Test environments.....</b>	<b>7</b>
4.4.1 Temperature and power supply voltage.....	7
4.4.1.1 Definition .....	7
4.4.1.2 Method of Measurement.....	7
4.4.1.3 [Minimum Standard].....	8
4.4.2 High Humidity .....	8
4.4.2.1 Definition .....	8
4.4.2.2 Method of Measurement.....	8
<b>4.5 RF power control .....</b>	<b>8</b>
<b>4.6 Discontinuous transmission (DTX).....</b>	<b>8</b>
<b>4.7 Transmission diversity .....</b>	<b>8</b>
<b>4.8 Short Reverse Link Scrambling Code .....</b>	<b>8</b>
<b>4.9 Reverse Link Synchronous Transmission.....</b>	<b>8</b>
<b>4.10 Site Selection Diversity transmission power control(SSDT).....</b>	<b>8</b>
<b>4.11 Inter-BS synchronous operation.....</b>	<b>8</b>
<b>4.12 Selection of configurations for testing .....</b>	<b>9</b>
<b>4.13 BTS Configurations .....</b>	<b>9</b>
4.13.1 Receiver diversity.....	9
4.13.2 Duplexers .....	9
4.13.3 Power supply options .....	10

4.13.4	Ancillary RF amplifiers .....	10
4.13.5	BSS using antenna arrays.....	10
4.13.5.1	Receiver tests .....	11
4.13.5.2	Transmitter tests .....	11
<b>5</b>	<b>Format and interpretation of tests .....</b>	<b>11</b>
<b>6</b>	<b>Transmitter .....</b>	<b>12</b>
<b>6.1</b>	<b>General.....</b>	<b>12</b>
<b>6.2</b>	<b>Base station output power .....</b>	<b>12</b>
6.2.1	Base station maximum output power .....	12
6.2.1.1	Test Conditions and measurement method .....	12
6.2.1.2	Minimum requirement .....	13
<b>6.3</b>	<b>Frequency stability.....</b>	<b>13</b>
6.3.1	Test conditions and measurement method.....	13
6.3.2	Minimum requirement .....	13
<b>6.4</b>	<b>Clock Frequency accuracy .....</b>	<b>13</b>
6.4.1	Test conditions and measurement method.....	13
6.4.2	Minimum requirement .....	13
<b>6.5</b>	<b>Output power dynamics.....</b>	<b>13</b>
6.5.1	Inner loop power control .....	14
6.5.2	Power control steps.....	14
6.5.2.1	Test conditions and measurement method.....	14
6.5.2.2	Minimum requirement .....	15
6.5.3	Power control dynamic range.....	15
6.5.3.1	Test conditions and measurement method.....	15
6.5.3.2	Minimum requirements.....	16
6.5.4	Minimum transmit power.....	16
6.5.4.1	Test conditions and measurement method.....	16
6.5.4.2	Minimum requirement .....	17
6.5.5	Total power dynamic range.....	17
6.5.5.1	Test conditions and measurement method.....	17
6.5.5.2	Minimum requirement .....	18
6.5.6	Power control cycles per second.....	18
6.5.6.1	Test conditions and measurement method.....	18
<b>6.6</b>	<b>Transmitted RF carrier power versus time .....</b>	<b>19</b>
6.6.1	Definition.....	19
6.6.2	Test conditions and measurement method.....	19
6.6.3	Minimum requirement .....	20
6.6.4	Perch channel power.....	20
6.6.4.1	Test conditions and measurement method.....	20
6.6.4.2	Minimum requirement .....	20
<b>6.7</b>	<b>Output RF spectrum emissions.....</b>	<b>20</b>
6.7.1	Occupied bandwidth .....	20
6.7.2	Out of band emission.....	20
6.7.2.1	Spectrum emission mask .....	20
6.7.2.2	Adjacent Channel Leakage power Ratio (ACLR) .....	21
6.7.2.2.1	Test conditions and measurement method.....	21
6.7.2.2.2	Minimum requirement .....	21
6.7.2.3	Protection outside a licensee's frequency block .....	21
6.7.2.3.1	Minimum requirement .....	22
6.7.3	Spurious emissions.....	22

6.7.3.1	Mandatory Requirements .....	22
6.7.3.2	Test conditions and measurement method.....	22
6.7.3.3	Minimum requirement .....	23
6.7.3.4	Spurious emissions (Category A) .....	23
6.7.3.4.1	Minimum Requirement .....	23
6.7.3.4.2	Spurious emissions (Category B) .....	24
6.7.3.4.3	Minimum Requirement .....	24
6.7.3.5	Protection of the BS receiver .....	24
6.7.3.5.1	Minimum Requirement .....	24
6.7.3.6	Co-existence with GSM 900.....	25
6.7.3.6.1	Operation in the same geographic area.....	25
6.7.3.6.1.1	Minimum Requirement .....	25
6.7.3.6.2	Co-located base stations .....	25
6.7.3.6.2.1	Minimum Requirement .....	25
6.7.3.7	Co-existence with DCS 1800 .....	25
6.7.3.7.1	Operation in the same geographic area.....	25
6.7.3.7.1.1	Minimum Requirement .....	26
6.7.3.7.2	Co-located basestations .....	26
6.7.3.7.2.1	Minimum Requirement .....	26
6.7.3.8	Co-existence with PHS .....	26
6.7.3.8.1	Minimum Requirement .....	26
<b>6.8</b>	<b>Transmit intermodulation .....</b>	<b>26</b>
6.8.1	Test conditions and measurement method.....	27
6.8.2	Minimum requirement .....	28
<b>6.9</b>	<b>Transmit modulation .....</b>	<b>28</b>
6.9.1	Modulation Accuracy.....	28
6.9.1.1	Test conditions and measurement method.....	28
6.9.1.2	Minimum requirement .....	29
6.9.2	Peak code Domain error .....	29
6.9.2.1	Minimum requirement .....	29
<b>7</b>	<b>Receiver characteristics.....</b>	<b>30</b>
<b>7.1</b>	<b>General.....</b>	<b>30</b>
<b>7.2</b>	<b>Reference sensitivity level.....</b>	<b>30</b>
7.2.1	Test conditions and measurement methods .....	30
7.2.2	Minimum requirement .....	31
<b>7.3</b>	<b>Dynamic range.....</b>	<b>31</b>
<b>7.4</b>	<b>Adjacent Channel Selectivity (ACS).....</b>	<b>32</b>
7.4.1	Test conditions and measurement method.....	32
7.4.2	Minimum requirement .....	32
<b>7.5</b>	<b>Blocking characteristics .....</b>	<b>33</b>
7.5.1	Test conditions and measurement method.....	33
7.5.2	Minimum requirement .....	34
<b>7.6</b>	<b>Spurious response.....</b>	<b>34</b>
7.6.1	Test conditions and measurement method.....	34
7.6.2	Minimum requirement .....	35
<b>7.7</b>	<b>Intermodulation characteristics .....</b>	<b>35</b>
7.7.1	Test conditions and measurement method.....	36
<b>7.8</b>	<b>Spurious emissions.....</b>	<b>37</b>

<b>8</b>	<b><i>Performance requirement</i></b> .....	<b>38</b>
<b>8.1</b>	<b><i>General</i></b> .....	<b>38</b>
<b>8.2</b>	<b><i>BS Dynamic reference sensitivity performance</i></b> .....	<b>38</b>
8.2.1	Performance in AWGN channel.....	38
8.2.1.1	Single link performance .....	38
8.2.2	Performance in multipath fading channels.....	38
8.2.2.1	Single link performance .....	38
8.2.2.2	Performance without TPC.....	38
8.2.2.3	Performance with TPC.....	39
8.2.2.4	Uplink power control.....	39
8.2.2.5	Softer handover performance .....	39
<b>Annex</b>	<b><i></i></b> .....	<b>40</b>
<b>A.1</b>	<b><i>Detailed definition of error events</i></b> .....	<b>40</b>
<b>Annex A (Informative):</b>	<b><i>Open items with solution proposals</i></b> .....	<b>41</b>
<b>History</b>	<b><i></i></b> .....	<b>47</b>

---

# Intellectual Property Rights

<Editor's note: IPR notice shall be provided once correct notice is available within 3GPP>

IPRs essential or potentially essential to the present document may have been declared to ETSI. The information pertaining to these essential IPRs, if any, is publicly available for **ETSI members and non-members**, and can be found in ETR 314: "Intellectual Property Rights (IPRs); Essential, or potentially Essential, IPRs notified to ETSI in respect of ETSI standards", which is available **free of charge** from the ETSI Secretariat. Latest updates are available on the ETSI Web server (<http://www.etsi.fr/ipr>).

Pursuant to the ETSI Interim IPR Policy, no investigation, including IPR searches, has been carried out by ETSI. No guarantee can be given as to the existence of other IPRs not referenced in ETR 314 (or the updates on <http://www.etsi.fr/ipr>) which are, or may be, or may become, essential to the present document.

---

## Foreword

This Technical Specification has been produced by the 3GPP.

The contents of the present document are subject to continuing work within the TSG and may change following formal TSG approval. Should the TSG modify the contents of this TS, it will be re-released by the TSG with an identifying change of release date and an increase in version number as follows:

Version x.y.z

where:

x the first digit:

- 1 presented to TSG for information;
- 2 presented to TSG for approval;
- 3 Indicates TSG approved document under change control.

Y the second digit is incremented for all changes of substance, i.e. technical enhancements, corrections, updates, etc.

z the third digit is incremented when editorial only changes have been incorporated in the specification;

---

## 1 Scope

This document establishes the minimum RF characteristics of the FDD mode of UTRA for the Base Station BS .

---

## 2 References

~~[Editor's note: Shall be revised later.]~~

- [1] 3GPP TS 25.104: "UTRA(BS) FDD; Radio transmission and Reception"
- [2] 3GPP TS25.942; "RF system scenarios"
- [3] ITR-R recommendation SM.329-7 "Spurious emissions"
- [4] GSM 11.21 (EN301 087 V5.4.0) "Digital Cellular telecommunications system (Phase 2 & Phase 2+); Base Station System (BSS) equipment specification; Radio aspects"

[5] ARIB, Volume 5 (V.1.0-01), "Specification of Base Station for 3G Mobile System"

The following documents contain provisions, which, through reference in this text, constitute provisions of the present document.

- References are either specific (identified by date of publication, edition number, version number, etc.) or non-specific.
- For a specific reference, subsequent revisions do not apply.
- For a non-specific reference, subsequent revisions do apply.

A non-specific reference to an ETS shall also be taken to refer to later versions published as an EN with the same number.

---

## 3 Definitions and abbreviations

### 3.1 Definitions

*[Editor's note: To be filled in later.]*

For the purposes of the present document, the following definitions apply:

Power Setting	The value of the control signal, which determines the desired transmitter, output Power. Typically, the power setting would be altered in response to power control commands
Maximum Power Setting	The highest value of the Power control setting which can be used.
Maximum output Power	This refers to the measure of power when averaged over the transmit timeslot at the maximum power setting.
Peak Power	The instantaneous power of the RF envelope which is not expected to be exceeded for [99.9%] of the time
Maximum peak power	The peak power observed when operating at a given maximum output power.
Average transmit power	The average transmitter output power obtained over any specified time interval, including periods with no transmission.
Maximum average power	The average transmitter output power obtained over any specified time interval, including periods with no transmission, when the transmit time slots are at the maximum power setting.

### 3.2 Symbols

For the purposes of the present document, the following symbols apply:

<symbol> <Explanation>



### 3.3 Abbreviations

For the purposes of the present document, the following abbreviations apply:

<b>ACIR</b>	Adjacent Channel Interference Ratio
<b>ACLR</b>	Adjacent Channel Leakage power Ratio
<b>ACS</b>	Adjacent Channel Selectivity
<b>BS</b>	Base Station
<b>BER</b>	Bit Error Rate
<b>CW</b>	Continuous Wave (unmodulated signal)
<b>DL</b>	Down Link (forward link)
<b>DTX</b>	
<b>EIRP</b>	Effective Isotropic Radiated Power
<b>FDD</b>	Frequency Division Duplexing
<b>FER</b>	Frame Error Rate
<b>MER</b>	Message Error Rate
<b>PPM</b>	Parts Per Million
<b>RSSI</b>	Received Signal Strength Indicator
<b>SIR</b>	Signal to Interference ratio
<b>TDD</b>	Time Division Duplexing
<b>TPC</b>	Transmit Power Control
<b>UE</b>	User Equipment
<b>UL</b>	Up Link (reverse link)
<b>UTRA</b>	UMTS Terrestrial Radio Access

<i>Chip Rate</i>	Chip rate of W-CDMA system, equals to 3.84 M chips per second.
<i>SCCPCH</i>	Secondary Common Control Physical Channel.
<i>SCCPCH</i> $_E_c$	Average energy per PN chip for SCCPCH.
<i>Data</i> $_E_c$	Average energy per PN chip for the DATA fields in the DPCH.
<i>Data</i> $\frac{E_c}{I_o}$	The ratio of the received energy per PN chip for the DATA fields of the DPCH to the total received power spectral density at the UE antenna connector.
$\frac{Data\_E_c}{I_{or}}$	The ratio of the average transmit energy per PN chip for the DATA fields of the DPCH to the total transmit power spectral density.
<i>DPCH</i>	Dedicated Physical Channel

$DPCH\_E_c$	Average energy per PN chip for DPCH.
$\frac{DPCH\_E_c}{I_{or}}$	The ratio of the received energy per PN chip of the DPCH to the total received power spectral density at the UE antenna connector.
$DCH$	Dedicated Channel, which is mapped into Dedicated Physical Channel. DCH contains the data.
$E_b$	Average energy per information bit for the PCCPCH, SCCPCH and DPCH, at the UE antenna connector.
$\frac{E_b}{N_t}$	The ratio of combined received energy per information bit to the effective noise power spectral density for the PCCPCH, PCCPCH and DPCH at the UE antenna connector. Following items are calculated as overhead: pilot, TPC, TFCI, CRC, tail, repetition, convolution coding and Turbo coding.
$E_c$	Average energy per PN chip.
$\frac{E_c}{I_{or}}$	The ratio of the average transmit energy per PN chip for different fields or physical channels to the total transmit power spectral density.
$FACH$	Forward Access Channel
$F_{uw}$	Frequency of unwanted signal
<i>Information Data Rate</i>	Rate of the user information, which must be transmitted over the Air Interface. For example, output rate of the voice codec.
$I_o$	The total received power spectral density, including signal and interference, as measured at the UE antenna connector.
$I_{oc}$	The power spectral density of a band limited white noise source (simulating interference from other cells) as measured at the UE antenna connector.
$I_{or}$	The total transmit power spectral density of the Forward link at the base station antenna connector.
$\hat{I}_{or}$	The received power spectral density of the Forward link as measured at the UE antenna connector.
$ISCP$	Given only interference is received, the average power of the received signal after despreading to the code and combining. Equivalent to the RSCP value but now only interference is received instead of signal.
$N_t$	The effective noise power spectral density at the UE antenna connector.
$OCNS$	Orthogonal Channel Noise Simulator, a mechanism used to simulate the users or control signals on the other orthogonal channels of a Forward link.
$OCNS\_E_c$	Average energy per PN chip for the OCNS.
$\frac{OCNS\_E_c}{I_{or}}$	The ratio of the average transmit energy per PN chip for the OCNS to the total transmit power spectral density.
$PCCPCH$	Primary Common Control Physical Channel
$PCH$	Paging Channel

$PCCPCH \frac{E_c}{I_o}$	The ratio of the received PCCPCH energy per chip to the total received power spectral density at the UE antenna connector.
$\frac{PCCPCH\_E_c}{I_{or}}$	The ratio of the average transmit energy per PN chip for the PCCPCH to the total transmit power spectral density.
$Pilot\_E_c$	Average energy per PN chip for the Pilot field in the DPCH.
$Pilot \frac{E_c}{I_o}$	The ratio of the received energy per PN chip for the Pilot field of the DPCH to the total received power spectral density at the UE antenna connector.
$\frac{Pilot\_E_c}{I_{or}}$	The ratio of the average transmit energy per PN chip for the Pilot field of the DPCH to the total transmit power spectral density.
$TFCI\_E_c$	Average energy per PN chip for the TFCI field in the DPCH.
$TFCI \frac{E_c}{I_o}$	The ratio of the received energy per PN chip for the TFCI field of the DPCH to the total received power spectral density at the UE antenna connector.
$\frac{TFCI\_E_c}{I_{or}}$	The ratio of the average transmit energy per PN chip for the TFCI field of the DPCH to the total transmit power spectral density.
<b>RSCP</b>	Given only signal power is received, the average power of the received signal after despreading and combining
$TPC\_E_c$	Average energy per PN chip for the Transmission Power Control field in the DPCH.
$TPC \frac{E_c}{I_o}$	The ratio of the received energy per PN chip for the Transmission Power Control field of the DPCH to the total received power spectral density at the UE antenna connector.
$\frac{TPC\_E_c}{I_{or}}$	The ratio of the average transmit energy per PN chip for the Transmission Power Control field of the DPCH to the total transmit power spectral density.

## 3.4 Radio Frequency bands

### 3.4.1 Frequency bands

The radio frequency band of IMT-2000 is recommended by ITU as shown in Fig. 3.4-11.

The range of IMT-2000 frequency band is 1885 ~ 2025MHz and 2110 ~ 2200MHz. Some part of this frequency range is designated for MSS (Region 1/3: 1980 ~ 2010MHz and 2170 ~ 2200MHz, Region 2: 1980 ~ 2025MHz and 2160 ~ 2200MHz).

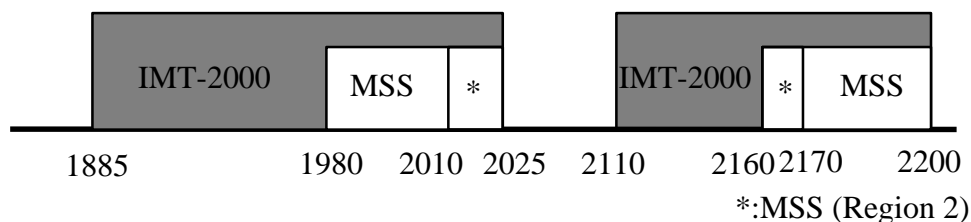

Fig. 3.4-13.4-13.4-1 Frequency band of IMT-2000

The range of Frequency band defined in 3GPP is shown in Fig. 3.4-4. (FDD mode Reverse Link: 1920 ~ 1980MHz, FDD mode Forward Link: 2110 ~ 2170MHz, FDD mode Duplex distance: 190MHz, TDD mode: 2010 ~ 2025MHz.)

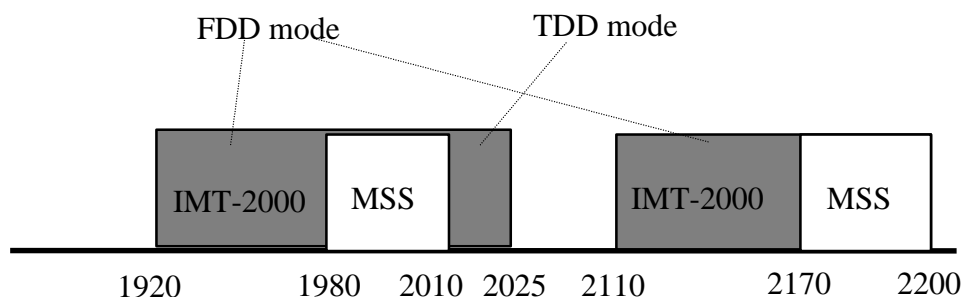

Fig. 3.4-43.4-33.4-2 Frequency band of the System

## 4 General test conditions and declarations

The requirements of this clause apply to all tests in this TS, when applicable.

Many of the tests in this TS measure a parameter relative to a value which is not fully specified in the UTRA specifications. For these tests, the conformance requirement is determined relative to a nominal value specified by the manufacturer.

Certain functions of a BTS are optional in the UTRA specifications.

When specified in a test, the manufacturer shall declare the nominal value of a parameter, or whether an option is supported.

### 4.1 Acceptable uncertainty of measurement equipment

The maximum acceptable uncertainty of measurement equipment is specified separately for each test, where appropriate. The measurement equipment shall enable the stimulus signals in the test case to be adjusted to within the specified tolerance. Compliance with the requirement is determined by comparing the measured value (or derived value from the measured one) with the specified limit, without making allowance for measurement uncertainty. All tolerances and uncertainties are absolute values, unless otherwise stated.

[Editor's note: To be filled in later.]

### 4.2 Interpretation of measurement results

The measurement value related to the corresponding limit shall be used to decide whether an equipment meets a requirement in this TS.

The measurement uncertainty for the measurement of each parameter shall be included in the test report.

The recorded value for the measurement uncertainty shall be, for each measurement, equal to or lower than the appropriate figure in subclause 4.1 of this TS.

If the measurement apparatus for a test is known to have a measurement uncertainty greater than that specified in subclause 4.1, it is still permitted to use this apparatus provided that an adjustment is made to the measured value as follows:

The adjustment is made by subtracting the modulus of the specified measurement uncertainty in subclause 4.1 from the measurement uncertainty of the apparatus. The measured value is then increased or decreased by the result of the subtraction, whichever is most unfavourable in relation to the limit.

## 4.3 Output power and determination of power class

The requirements in this specification apply to base station intended for general-purpose applications.

In the future further classes of base stations may be defined; the requirements for these may be different than for general-purpose applications.

## 4.4 Test environments

[Editor's note: This section has been tentatively taken from Sec.4.6, ARIB. Vol.5.]

### 4.4.1 Temperature and power supply voltage

#### 4.4.1.1 Definition

The temperature and voltage ranges denote the range of ambient temperature and power supply input voltages over which the base station will operate and meet the requirements of this standard. The ambient temperature is the average temperature of the air surrounding the base station equipment. The power supply voltage is the voltage applied at the input terminals of the base station equipment. The manufacturer is to specify the temperature range and the power supply voltage over which the equipment is to operate.

#### 4.4.1.2 Method of Measurement

The base station equipment shall be installed in its normal configuration (i.e., in its normal cabinet or rack mounting arrangement with all normally supplied cover installed) and placed in a temperature chamber. Optionally, the equipment containing the frequency determining element(s) may be placed in the temperature chamber if the frequency stability is to be maintained over a different temperature from that specified for the rest of the base station equipment.

The temperature chamber shall be stabilized at the manufacturer's highest specified operating temperature and then shall be operated in accordance with the standard duty cycle test conditions specified in section that describes standard test conditions, and over the power supply input voltage range specified by the manufacturer. With the base station equipment operating, the temperature is to be maintained at the specified test temperature without forced circulation of air from the temperature chamber being directly applied to the base station equipment.

During the entire duty cycle, the transmitter frequency accuracy, timing reference, output power, and waveform quality shall be measured as specified in section 6.1.1 Transmitter requirement.

Turn the base station equipment off, stabilize the equipment in the chamber at room temperature, and repeat the above measurements after a [ ] minute] standby warm up period.

Turn the base station equipment off, stabilize the equipment in the chamber at the coldest operating temperature specified by the manufacturer, and repeat the above measurements above after a [ ] minute] standby warm up period.

For transmitter frequency stability measurements, the above procedure shall be repeated every [ ] C° over the operating temperature range specified by the manufacturer. The equipment shall be allowed to stabilize at each step before a frequency measurement is made.

#### 4.4.1.3 [Minimum Standard]

### 4.4.2 High Humidity

#### 4.4.2.1 Definition

The term 'high humidity' denotes the relative humidity at which the base station will operate with no more than a specified amount of degradation in performance.

#### 4.4.2.2 Method of Measurement

The base station equipment, after having been adjusted for normal operation under standard test conditions, shall be placed, inoperative, in a humidity chamber with the humidity maintained at [0.024] gm H<sub>2</sub>O/gm Dry Air at [ C°] ([ %] relative humidity) for a period of not less than eight hours. While in the chamber and at the end of this period, the base station transmitting equipment shall be tested for frequency accuracy, timing reference, output power, and waveform quality. No readjustment of the base station equipment shall be allowed during this test.

## 4.5 RF power control

Both SIR based closed loop RF power control and open loop power control functions shall be implemented in Base Station Systems according to 25.104.

## 4.6 Discontinuous transmission (DTX)

Discontinuous transmission (DTX), as defined in the specifications, shall be implemented in BSS (transmitter).

## 4.7 Transmission diversity

Transmission diversity may optionally be implemented in BSS as an operator choice according to TS25.104[x]. All requirements in this specification, unless otherwise stated, apply whether Transmission diversity is used or not.

## 4.8 Short Reverse Link Scrambling Code

Short Reverse Link Scrambling Code may optionally be implemented in BSS as an operator choice according to TS25.104. All requirements in this specification, unless otherwise stated, apply whether this scheme is used or not.

## 4.9 Reverse Link Synchronous Transmission

Reverse Link Synchronous Transmission may optionally be implemented in BSS as an operator choice according to TS25.104. All requirements in this specification, unless otherwise stated, apply whether this scheme is used or not.

## 4.10 Site Selection Diversity transmission power control(SSDT)

Site Selection Diversity Transmission power control may optionally be implemented in BSS as an operator choice according to TS25.104. All requirements in this specification, unless otherwise stated, apply whether this scheme is used or not.

## 4.11 Inter-BS synchronous operation

~~[Editor's note: Inter-BS sync/async operation seems to have nothing to do with BS test.]~~

Inter-BS synchronous operation may optionally be implemented in BS as an operator choice according to [1]. All requirements in this specification, unless otherwise stated, apply whether this scheme is used or not.

## 4.12 Selection of configurations for testing

~~{Editor's note: To be revised later.}~~

Most tests in this TS are only performed for a subset of the possible combinations of test conditions. For instance:

- Not all TRXs in the configuration may be specified to be tested.
- Only one RF channel may be specified to be tested.
- Only one timeslot may be specified to be tested.

When a test is performed by a test laboratory, the choice of which combinations are to be tested shall be specified by the laboratory. The laboratory may consult with operators, the manufacturer or other bodies.

When a test is performed by a manufacturer, the choice of which combinations are to be tested may be specified by an operator.

## 4.13 BTS Configurations

~~{Editor's note: The following subclause shall be described later.}~~

### 4.13.1 Receiver diversity

i) For the tests in clause 7 of this TS, the specified test signals may be applied to one receiver antenna connector, with the remaining receiver antenna connectors being terminated with 50 ohms.

or

ii) For the tests in clause 7 of this TS, the specified test signals may be simultaneously applied to each of the receiver antenna connectors.

### 4.13.2 Duplexers

~~{Editor's note: Shall be revised later.}~~

The requirements of this TS shall be met with a duplexer fitted, if a duplexer is supplied as part of the BSS. If the duplexer is supplied as an option by the manufacturer, sufficient tests should be repeated with and without the duplexer fitted to verify that the BSS meets the requirements of this TS in both cases.

The following tests should be performed with the duplexer fitted, and without it fitted if this is an option:

- 1) Subclause 6.2.1~~6.3~~, Base station maximum output power~~Mean transmitted RF power~~, for the highest static power step only, if this is measured at the antenna connector.
- 2) Subclause 6.7~~6.2~~, Output RF spectrum emissions~~Conducted spurious emissions from the transmitter antenna connector~~; outside the BTS transmit band.
- 3) Subclause 6.7.3.5~~6.8~~, Protection of the BS receiver~~Intra base station system intermodulation attenuation~~.
- 4) Subclause 6.8~~7.4~~, Transmit intermodulation~~Multipath reference sensitivity~~; for the testing of **essential** conformance, the carrier frequencies ARFCNs should be selected to minimize intermodulation products from the transmitters falling in receive channels.

The remaining tests may be performed with or without the duplexer fitted.

NOTE 1: When performing receiver tests with a duplexer fitted, it is important to ensure that the output from the transmitters does not affect the test apparatus. This can be achieved using a combination of attenuators, isolators and filters.

NOTE 2: When duplexers are used, intermodulation products will be generated, not only in the duplexer but also in the antenna system. The intermodulation products generated in the antenna system are not controlled by ~~[3GPP]ETSI~~ specifications, and may degrade during operation (e.g. due to moisture ingress). Therefore, to ensure continued satisfactory operation of a BSS, an operator will normally select ARFCNs to minimize intermodulation products falling on receive channels. For testing of complete conformance, an operator may specify the ARFCNs to be used.

### 4.13.3 Power supply options

If the BSS is supplied with a number of different power supply configurations, it may not be necessary to test RF parameters for each of the power supply options, provided that it can be demonstrated that the range of conditions over which the equipment is tested is at least as great as the range of conditions due to any of the power supply configurations.

This applies particularly if a BSS contains a DC rail which can be supplied either externally or from an internal mains power supply. In this case, the conditions of extreme power supply for the mains power supply options can be tested by testing only the external DC supply option. The range of DC input voltages for the test should be sufficient to verify the performance with any of the power supplies, over its range of operating conditions within the BTS, including variation of mains input voltage, temperature and output current.

### 4.13.4 Ancillary RF amplifiers

**Ancillary RF amplifier:** a piece of equipment, which when connected by RF coaxial cables to the BTS, has the primary function to provide amplification between the transmit and/or receive antenna connector of a BTS and an antenna without requiring any control signal to fulfil its amplifying function.

The requirements of this TS shall be met with the ancillary RF amplifier fitted. At tests according to clause 6 and 7 for TX and RX respectively, the ancillary amplifier is connected to the BS by a connecting network ( including any cable(s), attenuator(s), etc.) with applicable loss to make sure the appropriate operating conditions of the ancillary amplifier and the BS. The applicable connecting network loss range is declared by the manufacturer. Other characteristics and the temperature dependence of the attenuation of the connecting network are neglected. The actual attenuation value of the connecting network is chosen for each test as one of the applicable extreme values. The lowest value is used unless otherwise stated.

Sufficient tests should be repeated with the ancillary amplifier fitted and, if it is optional, without the ancillary RF amplifier to verify that the BS meets the requirements of this TS in both cases.

### 4.13.5 BSS using antenna arrays

~~[Editor's note: Title only. Further contribution shall be needed.]~~

A BS may be configured with a multiple antenna port connection for some or all of its transceivers or with an antenna array related to one cell (not one array per transceiver). This section applies to a BS which meets at least one of the following conditions:

- The transmitter output signals from one or more transceiver appear at more than one antenna port, or
- there is more than one receiver antenna port for a transceiver or per cell and an input signal is required at more than one port for the correct operation of the receiver (NOTE: diversity reception does not meet this requirement) thus the outputs from the transmitters aswell as the inputs to the receivers are directly connected to several antennas (known as „aircombining“), or
- transmitters and receivers are connected via duplexers to more than one antenna

If a BS is used, in normal operation, in conjunction with an antenna system which contains filters or active elements which are necessary to meet the UTRA requirements, the tests of essential conformance may be performed on a system comprising the BS together with these elements, supplied separately for the purposes of testing. In this case, it must be demonstrated that the performance of the configuration under test is representative of the system in normal operation, and the conformance assessment is only applicable when the BS is used with the antenna system.

For testing of essential conformance of such a BS, the following procedure may be used:



### 4.13.5.1 Receiver tests

For each test, the test signals applied to the receiver antenna connectors shall be such that the sum of the powers of the signals applied equals the power of the test signal(s) specified in the test.

An example of a suitable test configuration is shown in Fig. 4.13-1.

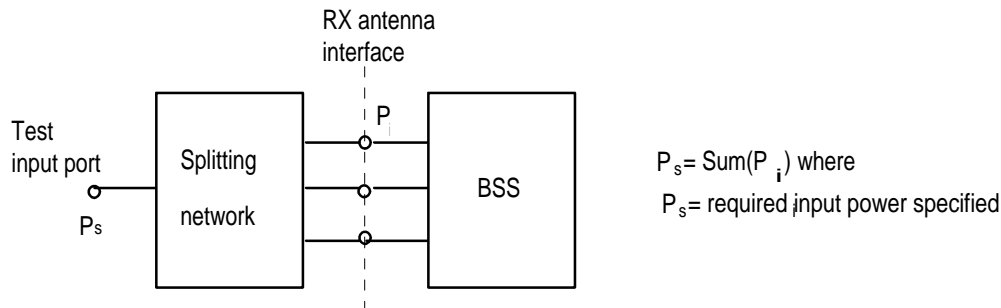

Fig. 4.13-1 Receiver test setup

For spurious emissions from the receiver antenna connector, the test may be performed separately for each receiver antenna connector.

### 4.13.5.2 Transmitter tests

For each test, the test signals applied to the receiver antenna connectors ( $P_i$ ) shall be such that the sum of the powers of the signals applied equals the power of the test signal(s) ( $P_s$ ) specified in the test. This may be assessed by separately measuring the signals emitted by each antenna connector and summing the results, or by combining the signals and performing a single measurement. The characteristics (e.g. amplitude and phase) of the combining network should be such that the power of the combined signal is maximised.

An example of a suitable test configuration is shown in Fig. 4.13-2.

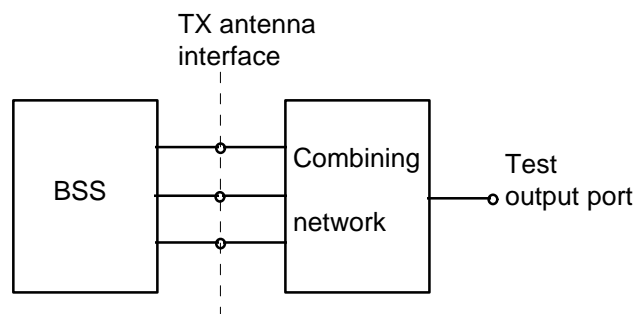

Fig. 4.13-2 Transmitter test setup

For Intermodulation attenuation, the test may be performed separately for each transmitter antenna connector.

## 5 Format and interpretation of tests

[Editor's note: Title only. Rearrangement shall be needed.]

Each test in the following clauses has a standard format:

### X Title

All tests are applicable to all equipment within the scope of this specification, unless otherwise stated.

**X.1 Test conditions and measurement method**

This sub-clause describes the steps necessary to perform the test.

**X.2 Minimum requirement**

This subclause describes the requirement which shall be met for the specified tests.

## 6 Transmitter

### 6.1 General

All tests in this Clause shall be conducted on Base Station Systems fitted with a full complement of Transceivers for the configuration unless otherwise stated. Measurements shall be made at the BS Tx antenna connector, unless otherwise stated.

Power levels are expressed in dBm.

### 6.2 Base station output power

Output power,  $P_{out}$ , of the base station is the mean power of one carrier delivered to a load with resistance equal to the nominal load impedance of the transmitter during one slot.

#### 6.2.1 Base station maximum output power

Maximum output power,  $P_{max}$ , of the base station is the mean power level per carrier that the manufacturer has declared to be available at the antenna connector.

##### 6.2.1.1 Test Conditions and measurement method

1. Connect the power measuring equipment to the base station RF output port.
2. Set the base station to transmit a signal modulated with a combination of PCCPCH, SCCPCH and Dedicated Physical Channels as stated below.
3. Measure the mean power at the RF output port.

~~Editor's note: Which code shall be measure?>~~

For those base station equipment tests that require multiple code channels be active simultaneously, the configuration shown in Table 6.2-1 should be used.

If a different number of Traffic Channels is used unless otherwise specified the partitioning of power shall be as shown in Table 6.2-1.

For Table 6.2-1 and Table 6.2-3, the fraction of power noted for each traffic channel shall be inclusive of power control bits.

Table 6.2-1 ~~6.2-1~~ **Base Station Test Model, Nominal**

Type	Number of Channels	Fraction of Power (Linear)	Fraction of Power (dB)	Comments
PCCPCH+ SCH	1	TBD	TBD	
SCCPCH	TBD	TBD	TBD	
Dedicated Physical	TBD	TBD	TBD	

Table 6.2-36.2-2 Base Station Test Model, General

Type	Relative Power
PCCPCH	TBD (linear)
SCCPCH + Dedicated Physical	Remainder (TBD) of total power (linear)
SCCPCH	TBD dB less than one Dedicated Physical Channel ; rate is TBD
Dedicated Physical	Equal Power in Each Traffic Channel ;

### 6.2.1.2 Minimum requirement

In normal conditions, the Base station maximum output power shall remain within +2 dB and –2dB of the manufacturer’s rated power.

In extreme conditions, the Base station maximum output power shall remain within +[ ] and –[ ] of the manufacturer’s rated power.

## 6.3 Frequency stability

Frequency stability is ability of the BS to transmit at the assigned carrier frequency.

### 6.3.1 Test conditions and measurement method

Frequency stability shall be measured by sampling the transmitter RF output.

1. Connect the frequency measuring equipment to the base station RF output port.
2. Set the base station to transmit a [CW signal | signal modulated with a combination of PCCPCH, SCCPCH and Dedicated Physical Channels as stated bellow] continuously with constant average power.
3. Measure the mean frequency at the RF output port.

### 6.3.2 Minimum requirement

The modulated carrier frequency of the BS shall be accurate to within  $\pm 0.05$  PPM for RF frequency generation.

## 6.4 Clock Frequency accuracy

<Editor’s note: Only for place holding. Detailed conformance requirement is for further study. >

### 6.4.36.4.1 Test conditions and measurement method

### 6.4.46.4.2 Minimum requirement

## 6.5 Output power dynamics

Power control is used to limit the interference level. The transmitter uses a quality-based power control on both the uplink and downlink.

## 6.5.1 Inner loop power control

Inner loop power control is the ability of the BS transmitter to adjust its output power in response to the UL/DL received signal.

For inner loop correction on the Downlink Dedicated Physical Channel (with respect to the open loop estimate), the base station adjust its mean output power level in response to each valid power control bit received from UE on the Uplink Dedicated Physical Channel.

## 6.5.2 Power control steps

The power control step is the minimum step change in the power of one of the physical channels transmitted by the DL transmitter.

### 6.5.2.1 Test conditions and measurement method

- 1) Connect the base station(BS) RF output port to the code domain analyzer or other suitable test equipment (via proper attenuator if needed.) Connect the BS RF input port to the UL signal generator or other suitable test equipment(Psudo UE) that can generate pre-determined UL signal sequences. If it is required, reference signal shall provided from Psudo UE to Code domain analyser. (See Configuration below.) ~~both the base stations under test and a code domain analyser as shown in the following figure.~~

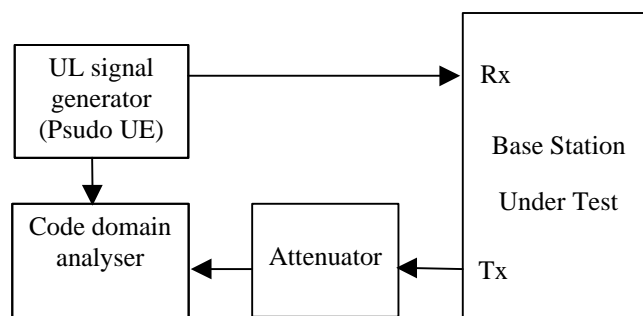

Fig. 6.5-16.5-16.5-1 Configuration for power control steps measurement

- 2) In the base station under test, set the frequency, disable inner loop power control in DPCH transmission test mode, and then set the transmission power.
- 3) Measure the transmission power to confirm it within **TBD** of the set value.
- 4) Start the TPC command transmission in the Pseudo UE~~code domain analyzer~~, and enable inner~~closed~~ loop power control in the base station under test.
- 5) Measure the absolute accuracy of transmission power in the base station under test each time TPC command is transmitted.
- 6) [Set the spectrum analyzer: center frequency is TRX transmission frequency, frequency span is zero-span, bandwidth of resolution is **TBD**, bandwidth of video is **TBD**, and range is **TBD**. Then measure the control step accuracy and control cycle of transmission power, and the transmission ramp up and ramp down time. Carry out the measurement in different symbol rates.]

<Editor's note: In which ~~h~~ symbol rate, code and by what method, should measurement done shall be specified.>

### 6.5.2.2 Minimum requirement

Down link step size 1 dB mandatory, 0.5dB optional

Step size tolerance ffs.

<Need to define the transmitter power as “code domain power”. This is ffs.>

### 6.5.3 Power control dynamic range

The power control dynamic range is difference between the maximum and the minimum transmit output power of a Dedicated Physical channel for a specified reference condition.

#### 6.5.3.1 Test conditions and measurement method

- 1) Configure both the base stations under test and a code domain analyzer as shown in the following figure.

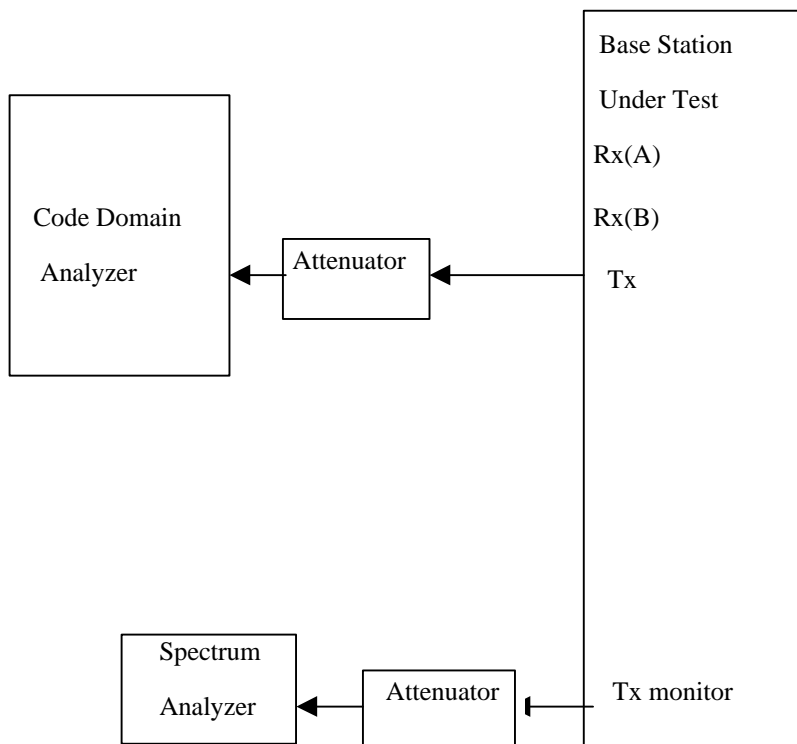

Fig. 6.5-46.5-36.5-2 Configuration for measurement

- 2) In the base station under test, set the frequency, disable closed loop power control in DPCH transmission test mode, and then set the transmission power.
- 3) Measure the transmission power to confirm it within **TBD** of the set value.
- 4) Start the TPC command transmission in the code domain analyzer, and enable closed loop power control in the base station under test.
- 5) Measure the absolute accuracy of transmission power in the base station under test each time TPC command is transmitted.
- 6) Set the spectrum analyzer: center frequency is TRX transmission frequency, frequency span is zero-span, bandwidth of resolution is **TBD**, bandwidth of video is **TBD**, and range is **TBD**. Then measure the control

step accuracy and control cycle of transmission power, and the transmission ramp up and ramp down time. Carry out the measurement in different symbol rates.

<Editor's note: In whichh symbol rate, should measurement done shall be specified.>

### 6.5.3.2 Minimum requirements

Down link (DL) power control dynamic range 25 dB

<Definition needs clarification. 25 dB is relative to  $P_{max} - 3$  dB.>

## 6.5.4 Minimum transmit power

The minimum controlled output power of the BS is when the power control setting is set to a minimum value. This is when the power control indicates a minimum transmit output power is required

### 6.5.4.1 Test conditions and measurement method

- 1) Configure both the base stations under test and a code domain analyzer as shown in the following figure.

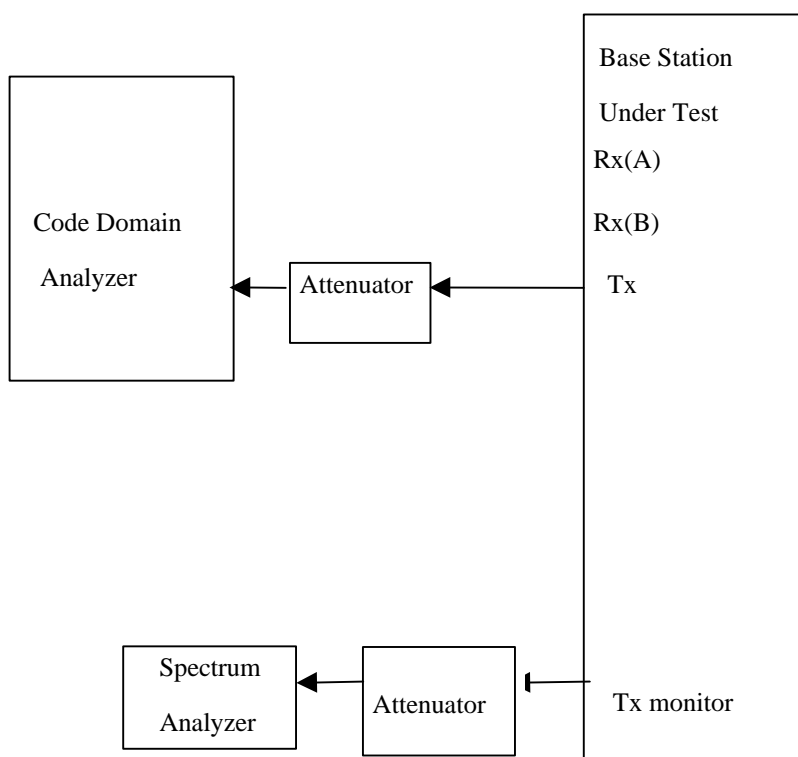

Fig. 6.5-76.5-56.5-3 Configuration for measurement

- 2) In the base station under test, set the frequency, disable closed loop power control in DPCH transmission test mode, and then set the transmission power.
- 3) Measure the transmission power to confirm it within **TBD** of the set value.
- 4) Start the TPC command transmission in the code domain analyzer, and enable closed loop power control in the base station under test.

- 5) Measure the absolute accuracy of transmission power in the base station under test each time TPC command is transmitted.
- 6) Set the spectrum analyzer: center frequency is TRX transmission frequency, frequency span is zero-span, bandwidth of resolution is **TBD**, bandwidth of video is **TBD**, and range is **TBD**. Then measure the control step accuracy and control cycle of transmission power, and the transmission ramp up and ramp down time. Carry out the measurement in different symbol rates.

<Editor's note: In whichh symbol rate, should measurement done shall be specified.>

#### 6.5.4.2 Minimum requirement

Down link (DL) minimum transmit power    Maximum output power – 18 dB

<The maximum output power definition is ffs.>

### 6.5.5 Total power dynamic range

The power control dynamic range is difference between the maximum and the minimum transmit output power for a specified reference condition.

#### 6.5.5.1 Test conditions and measurement method

- 1) Configure both the base stations under test and a code domain analyzer as shown in the following figure.

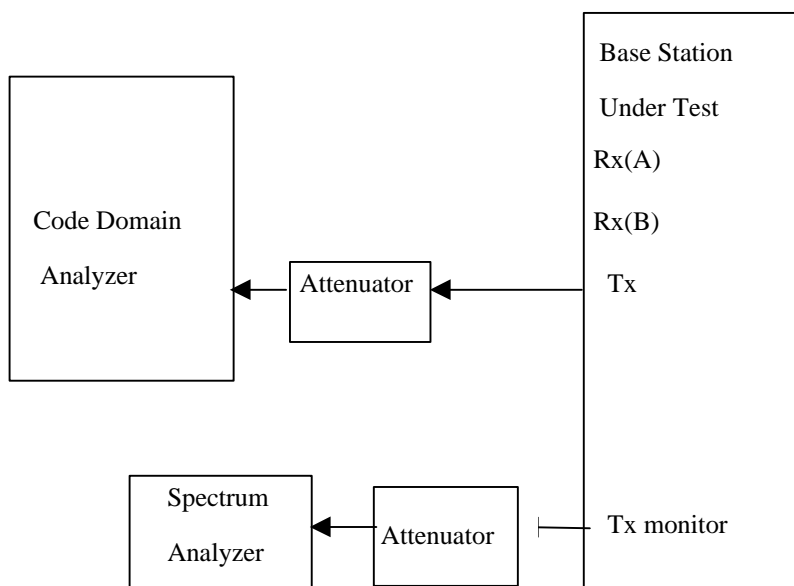

Fig. 6.5-106.5-76.5-4 Configuration for measurement

- 2) In the base station under test, set the frequency, disable closed loop power control in DPCH transmission test mode, and then set the transmission power.
- 3) Measure the transmission power to confirm it within **TBD** of the set value.

- 4) Start the TPC command transmission in the code domain analyzer, and enable closed loop power control in the base station under test.
- 5) Measure the absolute accuracy of transmission power in the base station under test each time TPC command is transmitted.
- 6) Set the spectrum analyzer: center frequency is TRX transmission frequency, frequency span is zero-span, bandwidth of resolution is **TBD**, bandwidth of video is **TBD**, and range is **TBD**. Then measure the control step accuracy and control cycle of transmission power, and the transmission ramp up and ramp down time. Carry out the measurement in different symbol rates.

<Editor's note: In whichh symbol rate, should measurement done shall be specified.>

### 6.5.5.2 Minimum requirement

Down link (DL) total power dynamic range 18 dB

<This requirement is redundant, since 6.5.4 defines the same dynamic range by a minimum transmit power.>

### 6.5.6 Power control cycles per second

The maximum rate of change for the DL transmitter power control step.

The Down link (DL) rate of power control steps is 1.5 kHz.

#### 6.5.6.1 Test conditions and measurement method

- 1) Configure both the base stations under test and a code domain analyzer as shown in the following figure.

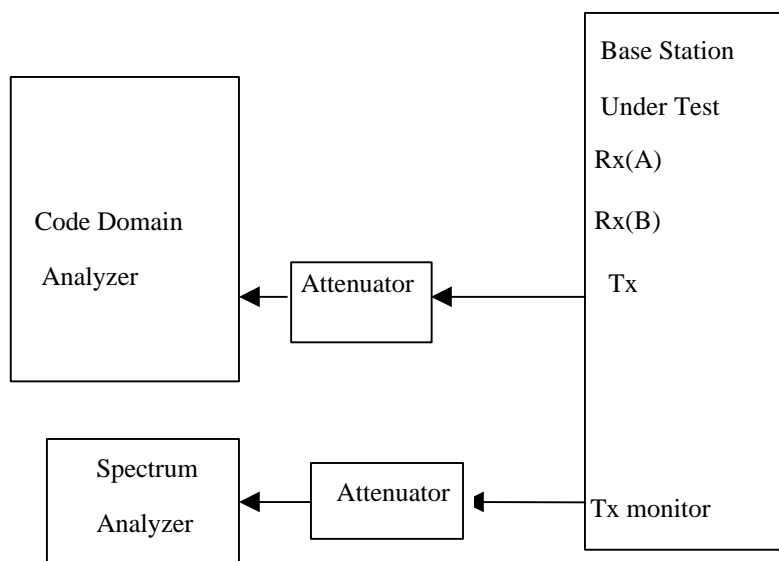

Fig. 6.5-136.5-96.5-5 Configuration for measurement

- 2) In the base station under test, set the frequency, disable closed loop power control in DPCH transmission test mode, and then set the transmission power.
- 3) Measure the transmission power to confirm it within **TBD** of the set value.
- 4) Start the TPC command transmission in the code domain analyzer, and enable closed loop power control in the base station under test.



- 5) Measure the absolute accuracy of transmission power in the base station under test each time TPC command is transmitted.
- 6) Set the spectrum analyzer: center frequency is TRX transmission frequency, frequency span is zero-span, bandwidth of resolution is **TBD**, bandwidth of video is **TBD**, and range is **TBD**. Then measure the control step accuracy and control cycle of transmission power, and the transmission ramp up and ramp down time. Carry out the measurement in different symbol rates.

<Editor’s note: In whichh symbol rate, should measurement done shall be specified.>

## 6.6 Transmitted RF carrier power versus time

[Editor’s note: This section is tentatively taken from Section 6.1.1.7 of ARIB Vol.5]

### 6.6.1 Definition

Transmission on/off ratio is a ratio of the mean power when transmitting and the radiation power in no signal state in the transmission frequency band.

### 6.6.2 Test conditions and measurement method

Refer to Fig. 6.6-1 for a functional block diagram of the test set-up.

1. Connect the base station RF output port to the spectrum analyser or other suitable test equipment.
2. Set the spectrum analyser condition as follows.
  - Median frequency : carrier frequency
  - Sweep spectrum range : 0MHz
  - Resolution bandwidth : Root raised cosine 3.84MHz
  - Video bandwidth : Video filtering not required
  - Sweep mode : Zero span
  - Sweep trigger : To be defined
  - Sweep time : To be defined
  - Detection mode : RMS power
3. Set the base station to transmit a signal modulated with a combination of PCCPCH, SCCPCH, and Dedicated Physical Channels as stated in Table 6.6-1.
  - Total power at the RF output port shall be the nominal power as specified by the manufacturer.
4. Measure the transmission on power.
5. Stop the transmission of the base station.
6. Measure the transmission off power.
7. Calculate the on/off ratio

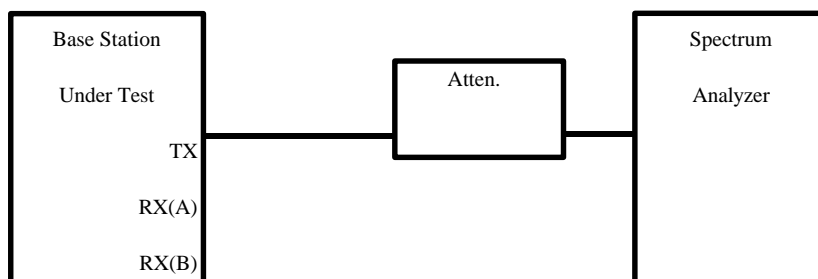

Fig. 6.6-1 ~~6.6-16.6-1~~ Functional Setup for Transmission on/off Ratio Test.

Table 6.6-1 ~~6.6-16.6-1~~ Base Station Test Model. Nominal

Type	Number of	Fraction of	Fraction of	Comments
------	-----------	-------------	-------------	----------

	Channels	Power( linear)	Power ( dB)	
PCCPCH	1	*****	*****	
SCH				
SCCPCH	1	*****	*****	
DPDCH+D PCCH	***	*****	*****	

### 6.6.3 Minimum requirement

The transmission on/off ratio shall be more than [ ] dB.

### 6.6.4 Perch channel power

The perch channel power, PCCPCH power, to total power ratio is the power attributed perch channel divided by the total power, and is expressed in dB. The SCH power is the averaged power during one frame.

#### 6.6.4.1 Test conditions and measurement method

1. Connect the RF output port of the BTS to the Code Domain Analyzer (the Code Domain Analyzer is the equipment that measure perch channel power) using an attenuator or directional coupler if necessary.

~~3.2.~~ Configure the BTS to transmit the signal modulated with a combination of the PCCPCHmmy), the 2nd perch channel and DPCH as described in 6.1.1.2.1.

~~4.3.~~ Measure the PCCPCH power to total power ratio.

#### 6.6.4.2 Minimum requirement

Each perch channel power to total power ratio is shall be within  $\pm$ TBD dB of the configured value.

<The name of the perch channel may need to be changed, subject to WG1 definition.>

## 6.7 Output RF spectrum emissions

### 6.7.1 Occupied bandwidth

Occupied bandwidth is a measure of the bandwidth containing 99% of the total integrated power for transmitted spectrum and is centered on the assigned channel frequency. The occupied channel bandwidth is less than 5 MHz based on a chip rate of 3.84 Mcps.

<Needs to be reviewed for the conformance specification.>

[Editor's note: Texts for measurement method are needed.]

### 6.7.2 Out of band emission

Out of band emissions are unwanted emissions immediately outside the [channel] bandwidth resulting from the modulation process and non-linearity in the transmitter but excluding spurious emissions. This out of band emission limit is specified in terms of a spectrum emission mask and adjacent channel power ratio for the transmitter.

#### 6.7.2.1 Spectrum emission mask

The emission mask of the base station is an item for further study.

## 6.7.2.2 Adjacent Channel Leakage power Ratio (ACLR)

Adjacent Channel Leakage power Ratio (ACLR) is the ratio of the transmitted power to the power measured after a receiver filter in the adjacent channel(s). Both the transmitted power and the received power are measured through a matched filter (Root Raised Cosine and roll-off 0.22) with a noise power bandwidth equal to the chip rate.

### 6.7.2.2.1 Test conditions and measurement method

1. Connect a spectrum analyzer or other suitable test equipment to the base station RF output port, using an attenuator or directional coupler if necessary.

2. The spectrum analyzer ( Digital storage type) is set as shown below.

Median frequency : carrier frequency and each of the adjacent channel frequencies

Sweep spectrum range: 0MHz

Resolution bandwidth : Root raised cosine 3.84MHz

Averaging : 1000 power averages

(for 0.2dB error at 95% confidence)

Sweep mode : Zero span

Sweep trigger : To be defined

Detection mode : True RMS(FDD)

3. Set the base station to transmit a signal modulated with a combination of BCCH1, BCCH2, FACH, and Dedicated Traffic Channels as stated in Table 6.7-1.

Total power at the RF output port shall be the nominal power as specified by the manufacturer.

4. Measure the power level at the carrier frequency.

5. Sweep the spectrum analyzer over an above sweep spectrum range at least.

Table 6.7-16.7-1 Base Station Test Model, Nominal

Type	Number of Channels	Fraction of Power( linear)	Fraction of Power ( dB)	Comments
PCCPCH	1	*****	*****	
SCH				
SCCPCH	1	*****	*****	
DPDCH+D PCCH	***	*****	*****	

### 6.7.2.2.2 Minimum requirement

Table 6.7-36.7-2 BS ACLR

BS channel	ACLR limit
± First adjacent channel	45 dB
± Second adjacent channel	[ 55 ] dB

Note: In order to ensure that switching transients due to the slotted mode do not degrade the ACLR value the reference measurements conditions are an item for further study.

### 6.7.2.3 Protection outside a licensee's frequency block

This requirement is applicable if protection is required outside a licensee's defined frequency block.

### 6.7.2.3.1 Minimum requirement

This requirement applies for frequencies outside the licensee's frequency block, up to an offset of 12.5MHz from a carrier frequency.

The power of any emission shall be attenuated below the transmit power (P) by at least  $43 + 10 \log (P)$ dB.

Compliance with this provision is based on the use of measurement instrumentation employing a resolution bandwidth of 1MHz or greater. However, in the 1MHz bands immediately outside and adjacent to the frequency block a resolution bandwidth of at least one percent of the fundamental emission of the transmitter may be employed. The emission bandwidth is defined as the width of the signal between two points, one below the carrier centre frequency and one above the carrier centre frequency, outside of which all emissions are attenuated at least 26dB below the transmitter power.

When measuring the emission limits, the nominal carrier frequency shall be adjusted as close to the licensee's frequency block edges, both upper and lower, as the design permits.

The measurements of emission power shall be mean power.

## 6.7.3 Spurious emissions

Spurious emissions are emissions which are caused by unwanted transmitter effects such as harmonics emission, parasitic emission, intermodulation products and frequency conversion products, but exclude out of band emissions. This is measured at the base station RF output port.

Unless otherwise stated, all requirements are measured as mean power.

### 6.7.3.1 Mandatory Requirements

The requirements of either subclause 6.7.3.4 or subclause 6.7.3.4.2 shall apply.

Either requirement applies at frequencies within the specified frequency ranges which are more than 12.5MHz from a [carrier frequency].

### 6.7.3.2 Test conditions and measurement method

1. Connect a spectrum analyzer or other suitable test equipment to the base station RF output port, using an attenuator or directional coupler if necessary.
2. The spectrum analyzer (Digital storage type) is set as shown below.

Median frequency	: spurious frequency
Sweep spectrum range	: [**]Hz
Resolution bandwidth	: [**]Hz
Video bandwidth	: Equivalent of resolution bandwidth
Y-axis scale	: 10dB/div

Sweep mode	: Single mode
Sweep trigger	: Freerun or video trigger. Generally + voltage, but adjustment is necessary.

Sweep time	: [**]msec
Detection mode	: Sample mode

3. Set the base station to transmit a signal modulated with a combination of PCCPCH, SCH, SCCPCH, and Dedicated Physical Channels as stated in Table 6.7-5. Total power at the RF Output port shall be the nominal power as specified by the manufacturer.

4. Measure the power level at the carrier frequency.

5. Sweep the spectrum analyzer over a frequency range from a low radio frequency ( about 25 MHz) to three times the carrier frequency at least.

Table 6.7-~~56.7-3~~ Base Station Test Model, Nominal

Type	Number Of Channels	Fraction of Power(linear)	Fraction Of Power(dB)	Comments
PCCPCH	1	[**]	[**]	
SCH				
SCCPCH	1	[**]	[**]	
DPDCH+DPC CH	[**]	[**]	[**]	

### 6.7.3.3 Minimum requirement

The spurious emission level against the mean output power of the base station in the Transmission band shall not exceed the limits specified below.

In the (a) Concerned Operator's System Bands and the (b) Other Bands Within Cellular Band, the spurious emission level within a [\*\*]kHz bandwidth shall not exceed a level Specified in the Table 6.7-7. In the (c) Other Bands, the spurious emission level within a 1MHz bandwidth shall not exceed a level specified in the Table 6.7-7. Each transmission band is defined as follows:

- (a) Concerned Operator's System Bands: The bands of the concerned operator's system used for this CDMA system.
- (b) Other Bands Within Cellular Band: The 2.0G-band including other operator's cellular system bands, but excluding the (a) Concerned Operator's System Bands.
- (c) Other Bands: Other bands entirely consisting of all frequencies, but excluding the above bands (a) and (b).

Table 6.7-~~76.7-4~~ Spurious Emission Limits When Transmitting.

Measurement Band	Maximum Spurious Emission Level
Concerned Operator's System Bands	Shown the Adjacent channel leakage power in [tbd]
Other Bands Within Cellular Band	-[**]dB/[**]kHz or [**] μW(-[**]dBm)/[**]kHz, whichever the level is smaller.
Other Bands	If the mean transmission power is no more than 25W: 25μW(-16dBm)/1MHz or less. If the mean transmission power is more than 25W: -60dBc/1MHz or less, and 20mW(+13dBm)/1MHz or less. [current rules in each country shall apply.]

### 6.7.3.4 Spurious emissions (Category A)

The following requirements shall be met in cases where Category A limits for spurious emissions, as defined in ITU-R Recommendation ITR-R recommendation SM.329-7 "Spurious emissions"[3], are applied.

#### 6.7.3.4.1 Minimum Requirement

The power of any spurious emission shall be attenuated by at least the minimum requirement:

Table 6.7-~~96.7-5~~ BS Mandatory spurious emissions limits, Category A

Band	Minimum attenuation requirement	Measurement Bandwidth	Note
9kHz – 150kHz	43 + 10logP (dB)	1 kHz	Bandwidth as in ITU SM.329-7, s4.1
150kHz – 30MHz		10 kHz	Bandwidth as in ITU SM.329-7, s4.1
30MHz – 1GHz		100 kHz	Bandwidth as in ITU SM.329-7, s4.1
1GHz – [11GHz]		1 MHz	Upper frequency as in ITU SM.329-7, s2.6

P = Mean power (W) where  $P < 500W$

#### 6.7.3.4.2 Spurious emissions (Category B)

The following requirements shall be met in cases where Category B limits for spurious emissions, as defined in ITU-R Recommendation ITR-R recommendation SM.329-7 “Spurious emissions”[3], are applied.

#### 6.7.3.4.3 Minimum Requirement

The power of any spurious emission shall not exceed:

Table 6.7-~~116.7-6~~ BS Mandatory spurious emissions limits

Band	Maximum Level	Measurement Bandwidth	Note
9kHz – 150kHz	-36 dBm	1 kHz	Bandwidth as in ITU SM.329-7, s4.1
150kHz – 30MHz	- 36 dBm	10 kHz	Bandwidth as in ITU SM.329-7, s4.1
30MHz – 1GHz	-36 dBm	100 kHz	Bandwidth as in ITU SM.329-7, s4.1
1GHz – [11GHz]	-30 dBm	1 MHz	Upper frequency as in ITU SM.329-7, s2.6

#### 6.7.3.5 Protection of the BS receiver

This requirement may be applied in order to prevent the receiver of the BS being desensitised by emissions from the BS transmitter which are coupled between the antennas of the BS.

[This requirement assumes the scenario described in [2].] For different scenarios, the manufacturer may declare a different requirement.

This requirement is not applicable to antenna ports which are used for both transmission and reception (e.g. which have an internal duplexer).

NOTE: In this case, the measurement of Reference Sensitivity will directly show any desensitisation of the receiver.

#### 6.7.3.5.1 Minimum Requirement

The power of any spurious emission shall not exceed:

Table 6.7-136.7-7 BS Spurious emissions limits for protection of the BS receiver

Band	Maximum Level	Measurement Bandwidth	Note
1920 – 1980MHz	-[78] dBm	100 kHz	

### 6.7.3.6 Co-existence with GSM 900

#### 6.7.3.6.1 Operation in the same geographic area

This requirement may be applied for the protection of GSM 900 MS in geographic areas in which both GSM 900 and UTRA are deployed.

[This requirement assumes the scenario described in [2].] For different scenarios, the manufacturer may declare a different requirement.

##### 6.7.3.6.1.1 Minimum Requirement

The power of any spurious emission shall not exceed:

Table 6.7-156.7-8 BS Spurious emissions limits for BS in geographic coverage area of GSM 900

Band	Maximum Level	Measurement Bandwidth	Note
921 – 960 MHz	-[47] dBm	100 kHz	

#### 6.7.3.6.2 Co-located base stations

This requirement may be applied for the protection of GSM 900 BTS receivers when GSM 900 BTS and UTRA BS are co-located.

[This requirement assumes the scenario described in [2].] For different scenarios, the manufacturer may declare a different requirement.

##### 6.7.3.6.2.1 Minimum Requirement

The power of any spurious emission shall not exceed:

Table 6.7-176.7-9 BS Spurious emissions limits for protection of the BS receiver

Band	Maximum Level	Measurement Bandwidth	Note
876-915 MHz	- -[98]dBm	100 kHz	

### 6.7.3.7 Co-existence with DCS 1800

#### 6.7.3.7.1 Operation in the same geographic area

This requirement may be applied for the protection of DCS 1800 MS in geographic areas in which both DCS 1800 and UTRA are deployed.

[This requirement assumes the scenario described in [2].] For different scenarios, the manufacturer may declare a different requirement.

### 6.7.3.7.1.1 Minimum Requirement

The power of any spurious emission shall not exceed:

Table 6.7-19 ~~6.7-10~~ *BS Spurious emissions limits for BS in geographic coverage area of DCS 1800*

Band	Maximum Level	Measurement Bandwidth	Note
1805 – 1880 MHz	[-57] dBm	100 kHz	

### 6.7.3.7.2 Co-located basestations

This requirement may be applied for the protection of DCS 1800 BTS receivers when DCS 1800 BTS and UTRA BS are co-located.

[This requirement assumes the scenario described in [2].] For different scenarios, the manufacturer may declare a different requirement.

#### 6.7.3.7.2.1 Minimum Requirement

The power of any spurious emission shall not exceed:

Table 6.7-21 ~~6.7-11~~ *BS Spurious emissions limits for BS co-located with DCS 1800 BTS*

Band	Maximum Level	Measurement Bandwidth	Note
1710-1785 MHz	-[98]dBm	100 kHz	

### 6.7.3.8 Co-existence with PHS

This requirement may be applied for the protection of PHS in geographic areas in which both PHS and UTRA are deployed.

#### 6.7.3.8.1 Minimum Requirement

The power of any spurious emission shall not exceed:

Table 6.7-23 ~~6.7-12~~ *BS Spurious emissions limits for BS in geographic coverage area of PHS*

Band	Maximum Level	Measurement Bandwidth	Note
1893.5 – 1910 MHz	-40 dBm	300 kHz	

## 6.8 Transmit intermodulation

The transmit intermodulation performance is a measure of the capability of the transmitter to inhibit the generation of signals in its non linear elements caused by presence of the wanted signal and an interfering signal reaching the transmitter via the antenna.

The transmit intermodulation shall be defined by the ratio of the output power of subject transmitted signal to the output power of intermodulation product when an interference signal (that differs from frequency of subject signal) is added at a level [\*\*]dB lower than that of the subject signal. The frequency of the interference signal shall be [\*\*]MHz or more off the subject signal, however, as for interference signal whose frequency is in the range of 5MHz to 10MHz off the subject signal, adjacent channel leakage power is used instead of the output of intermodulation product.



## 6.8.1 Test conditions and measurement method

1. Configure the base station according to the test model described in Fig. 6.8-1.
2. Conditions for measuring instrument is set as follows:
  - (1) The transmitting wave must have enough directivity so that no leak nor measurement error occurs in the standard signal generator.
  - (2) Setting of standard signal generator  
Median frequency: Transmission average frequency [\*\*]MHz
  - (3) The spectrum analyzer (Digital storage type) or other suitable test equipment is set as shown below.
 

Median frequency	: Intermodulation spurious frequency
Sweep spectrum range	: [**]Hz
Resolution bandwidth	: [**]Hz
Video bandwidth	: Equivalent of resolution bandwidth
Y-axis scale	: 10dB/div
Sweep mode	: Single mode
Sweep trigger	: Freerun or video trigger. Generally + voltage, but adjustment is necessary.
Sweep time	: [**]msec
Detection mode	: Sample mode
3. *Set the base station to transmit a signal modulated with a combination of PCCPCH, SCH, SCCPCH, and Dedicated Physical Channels as stated in Table 6.8-1.*
4. Set the median Frequency of the standard signal generator at the carrier +[\*\*]MHz (or -[\*\*]MHz) and set the output level of standard signal generator so that a maximum transmission output of -[\*\*]dB is in terms of the unit under test antenna output end calculation.
5. Set the switching selector on the unit under test side and obtain power of transmission intermodulated wave by the spectrum analyzer.
6. The ratio of the maximum transmission output and the maximum value of power obtained in 2 corresponds to the transmission intermodulation.

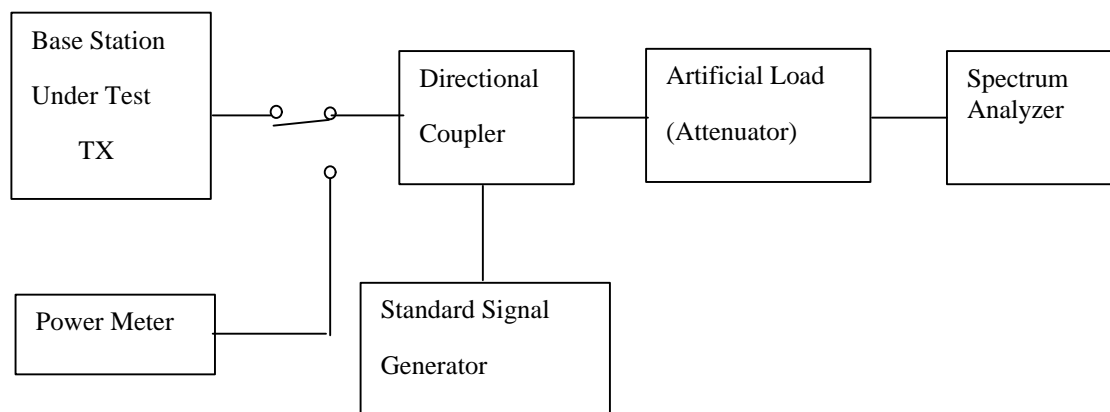

Fig. 6.8-16.8-16.8-1 Functional Setup for Base Station Intermodulation Spurious Response Testes

Table 6.8-16.8-1 Base Station Test Model. Nominal

Type	Number of Channels	Fraction of Power( linear)	Fraction of Power ( dB)	Comments
PCCPCH	1	*****	*****	
SCCPCH	1	*****	*****	
DPDCH+DPCCH	***	*****	*****	

## 6.8.2 Minimum requirement

The Transmit intermodulation level against the mean output power per carrier of the base station shall not exceed the limits specified below.

[If the mean transmission power is no more than 25W : 25µW(-16dBm) / 1MHz or less.]

[If the mean transmission power is more than 25W : -60dBc/1MHz or less, and 20mW (+13dBm) / 1MHz or less.]

<This is based on ARIB input. Further input for co-located cellular systems is needed.>

## 6.9 Transmit modulation

### 6.9.1 Modulation Accuracy

The modulation accuracy is a measure of the difference between the measured waveform and the theoretical modulated waveform (the error vector). It is the square root of the ratio of the mean error vector power to the mean reference signal power expressed as a %. The measurement interval is one power control group (timeslot)

#### 6.9.1.1 Test conditions and measurement method

Refer to Figure 6.1.1.6-1 for a functional block diagram of the test setup.

1. Connect the base station RF output port to the modulation analyzer with root-nyquist receive filter function.

2. Set the base station to transmit a signal modulated with PCCPCH. Total power at the RF output port shall be the nominal power as specified by the manufacturer.
3. Trigger the test equipment from the system time reference signal from the base station.
4. Measure the modulation accuracy factor.

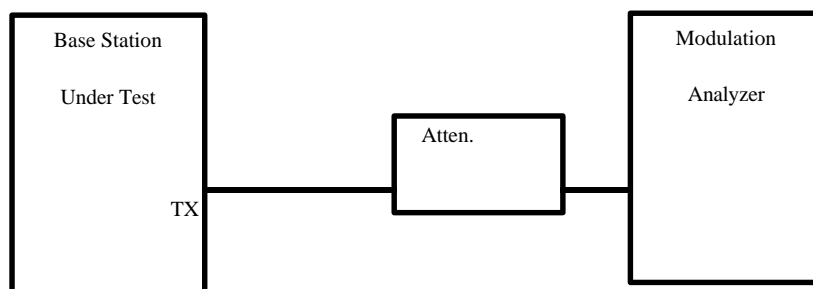

Fig. 6.9-~~16.9-16.9-1~~ Functional Setup for Modulation Accuracy Test.

### 6.9.1.2 Minimum requirement

The Modulation accuracy shall not be worse than 12.5 %.

## 6.9.2 Peak code Domain error

The code domain error is computed by projecting the error vector power onto the code domain at the maximum spreading factor. The error vector for each power code is defined as the ratio to the mean power of the reference waveform expressed in dB. The peak code domain error is defined as the maximum value for the code domain error. The measurement interval is one power control group (timeslot).

### 6.9.2.1 Minimum requirement

The peak code domain error shall not exceed [ ] dB

## 7 Receiver characteristics

### 7.1 General

All tests unless otherwise stated in this subclause shall be conducted on Base Station Systems fitted with a full complement of Transceivers for the configuration. Measurements shall include any RX multicoupler.

The tests in this subclause assume that the receiver is not equipped with diversity. For receivers with diversity, the tests may be performed by applying the specified signals to one of the receiver inputs, and terminating or disabling the other(s). The tests and requirements are otherwise unchanged.

For receivers with diversity, unless otherwise stated, testing shall be performed by applying the specified signals to one of the receiver inputs, and terminating or disabling the other(s).

In all the relevant subclauses in this clause all Bit Error Ratio (BER), Residual BER (RBER) and Frame Erasure Ratio (FER) measurements shall be carried out according to the general rules for statistical testing in annex A.

~~Unless detailed the receiver characteristic are specified at each antenna connector of the BS.~~

~~<Definition of requirements for antenna diversity is ffs.>~~

<Definition of test channel is required. They shall be attached in Annex.>

### 7.2 Reference sensitivity level

The reference sensitivity is the minimum receiver input power measured at the antenna connector at which the FER/BER does not exceed the specific value indicated in section 7.2.27.3.1. The signal power is equally applied to each antenna connector for diversity.

#### 7.2.1 Test conditions and measurement methods

This test is performed without interfering signal with equal power applied to each RF input branch according to Fig. 7.2-1 ~~Figure 6.1.2.1.2-1~~. In the case duplex operation is supported, the measurement configuration principle is indicated for one duplex branch in Fig. 7.2-3 ~~Figure 6.1.2.1.2-2~~. The reference point for signal power is at the input of each receiver (antenna connector).

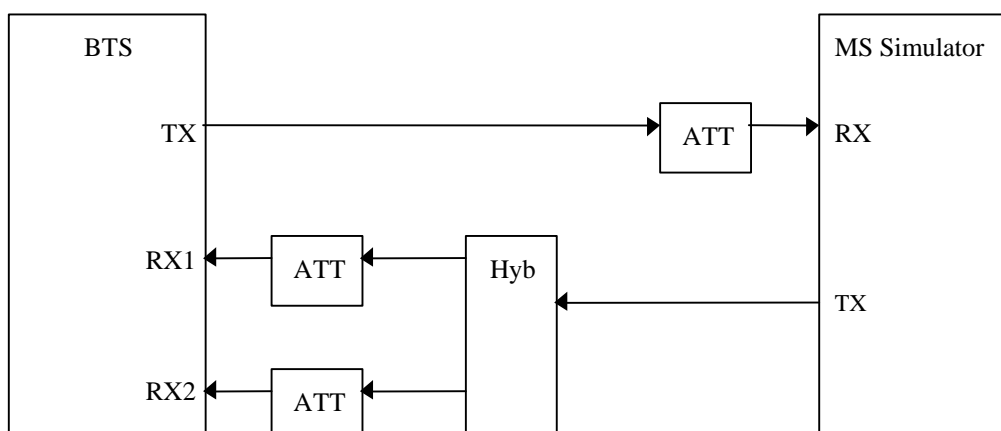

Fig. 7.2-1 ~~7.2-1~~ Functional Setup for Base Station Reference sensitivity level Testes (without duplex operation case)

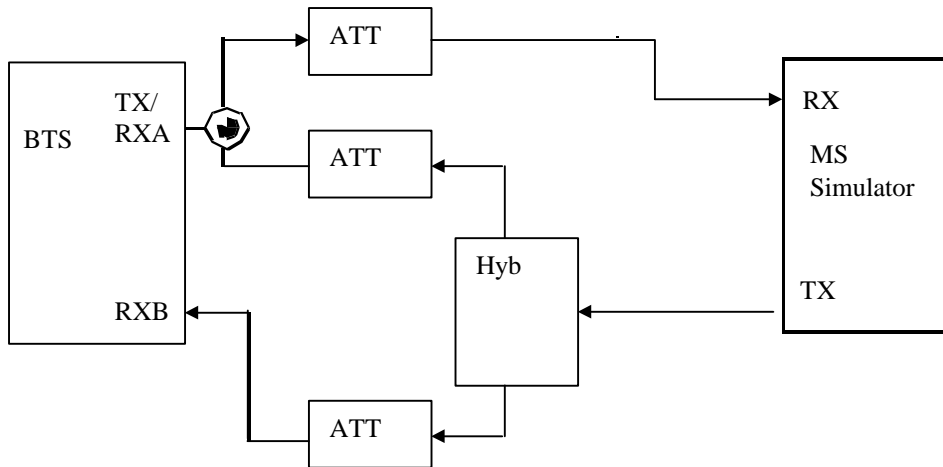

Fig. 7.2-~~37.2-27.2-2~~ Functional Setup for Base Station Reference Sensitivity level Testes (*with duplexing operation case*)

For each transport channel information rate and bearer service for which sensitivity is specified by the manufacturer, the applicable test in Table 7.2-~~table 6.1.2.1.2-1~~ shall pass for an input signal equal to the specified sensitivity level.

~~[BER and UER measurement methods should be defined.]~~

### 7.2.2 Minimum requirement

For the different services with corresponding data rates, the reference sensitivity level of the BS shall be specified in Table 7.2-~~table 8~~ below.

Table 7.2-~~17.2-1~~ BS reference sensitivity levels

Data rate	BS reference sensitivity level (dBm)	FER/BER
12.2 kbps	-122 dBm	BER shall not exceed 0.001

<Editor: Should only be specified for a measurement channel.>

### ~~7.3 Maximum Frequency Deviation for Receiver Performance~~

~~The need for such a requirement is for further study.~~

### 7.47.3 Dynamic range

The receiver dynamic range is the input power range at each BS antenna connector over which the [FER/BER] does not exceed a specific rate.

The static [BER/BER] reference performance as specified in clause 7.~~27.3.1~~ should be met over a receiver input range of [30] dB above the specified reference sensitivity level for [channel type ffs].

<The effect of applying mast head LNAs to the dynamic range specification is ffs.>

## 7.57.4 Adjacent Channel Selectivity (ACS)

Adjacent channel selectivity (ACS) is a measure of the receiver ability to receive a wanted signal at its assigned channel frequency in the presence of an adjacent channel signal at a given frequency offset from the center frequency of the assigned channel. ACS is the ratio of the receiver filter attenuation on the assigned channel frequency to the receiver filter attenuation on the adjacent channel(s).

[Editor's note: Item only. Further study needed.]

The interference signal be detuned by  $\Delta f$  MHz and modulated by a pseudo random binary sequence with PN-15 stages.

### 7.4.1 Test conditions and measurement method

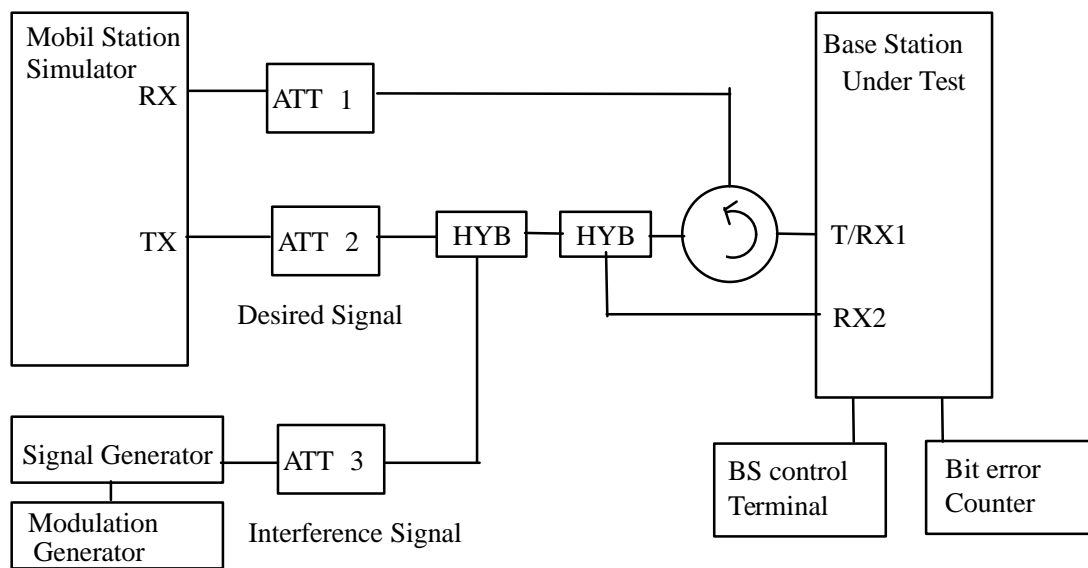

*Fig. 7.4-1 Measuring system Setup for Adjacent channel selectivity*

- (1) To make the measurement, set up the equipment as shown in Fig. 7.4-1. The Base station Under Test shall be connected through attenuator to Mobile Station simulator and measurement equipment.
- (2) Transmit a PCCPCH and a DPCH to the mobile station simulator from the base station under test.
- (3) Transmit DPCH to the base station under test from the mobile station simulator.
- (4) Disable Transmitter power control (TPC) function.
- (5) Adjust ATT2 to set input level of Base Station under Test to +6 dB higher level of the specified reference sensitivity level.
- (6) Set up the interference modulation signal to the adjacent channel frequency, then adjust ATT3, and obtain the level of interference signal such that  $[BER=1 \times 10^{-3}]$ .
- (7) Measure a difference between the level of an interference signal and the level of the specified reference sensitivity level + 6dB.

### 7.5.17.4.2 Minimum requirement

The static reference performance as specified in clause 7.2 should be met when the following signals are applied to the receiver;

- ~~—A wanted signal at the assigned channel frequency, 3 dB above the static reference level.~~
- ~~—A modulated interfering adjacent channel signal with a level of [ ] dBm.~~

<The specification will be based on an ACS value of [45] dB for the first adjacent channel.>

*Table 7.4-1 Adjacent channel selectivity*

<u>Parameter</u>		<u>Level</u>	<u>Unit</u>
<u>Data rate</u>		<u>12.2</u>	<u>Kbps</u>
<u>Wanted signal</u>		<u>Reference sensitivity level + 6dB</u>	<u>DBm</u>
<u>Un-Wanted signal (Modulated)</u>	<u>Level</u>	<u>-52</u>	<u>DBm</u>
	<u>Frequency separation</u>	<u>5</u>	<u>MHz</u>

## **7.67.5 Blocking characteristics**

The blocking characteristics is a measure of the receiver ability to receive a wanted signal at its assigned channel frequency in the presence of an unwanted interferer on frequencies other than those of the spurious response or the adjacent channels; without this unwanted input signal causing a degradation of the performance of the receiver beyond a specified limit. The blocking performance shall apply at all frequencies except those at which a spurious response occur.

### **7.6-17.5.1 Test conditions and measurement method**

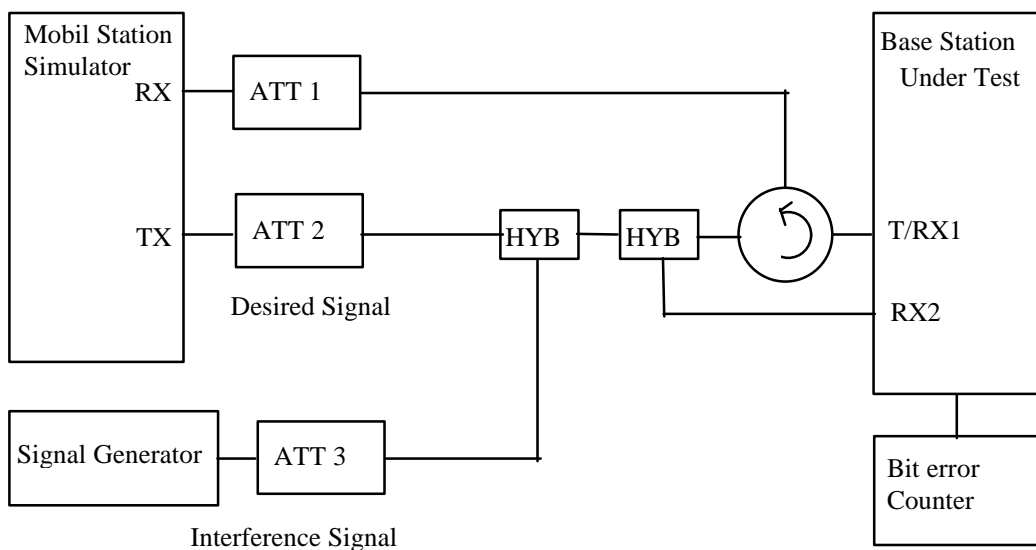

*Fig. 7.5-1 Measuring system Setup for Blocking characteristics*

- (1) Connect the BS to a mobile station simulator and a Signal generator.
- (2) Disable Transmitter power control (TPC) function.
- (3) Adjust the mobile station simulator to a level 6dB above the specified required reference sensitivity level.
- (4) Adjust the Signal generator level to the appropriate level for the BS type under test.
- (5) The signal generator shall now be swept over the specified frequency band with a defined increment.
- (6) The BS shall satisfy the [1x10<sup>-3</sup> BER] requirement for all signal generator frequencies above.
- (7) The requirement shall be met for all information rates and services specified for the BS.

### 7.6.27.5.2 Minimum requirement

The static reference performance as specified in clause 7.2 should be met with a wanted and an interfering signal coupled to BS antenna input using the following parameters.

The static reference performance as specified in clause 7.2 should be met when the following signals are applied to the receiver;

A wanted signal at the assigned channel frequency, 3 dB above the static reference level.

An interfering signal with a frequency offset of at least 10 MHz from the nominal assigned channel with a level and frequency range given below.

Table 7.5-1 Table 7.6-4 Blocking characteristics

Center Frequency of Interfering Signal	Interfering Signal Level	Type of Interfering Signal
1920 – 1980 MHz	-42 dBm	3.844.096 Mcps HPSK modulated signal
1900 – 1920 MHz 1980 – 2000 MHz	TBD	3.844.096 Mcps HPSK modulated signal
<1900, > 2000 MHz	TBD	CW carrier (preferred)

<The definition of the exemptions needs to be reconsidered, since it is unclear.>

### 7.7 Spurious response

Spurious response is a measure of the receiver’s ability to receive a wanted signal on its assigned channel frequency without exceeding a given degradation due to the presence of an unwanted CW interfering signal at any other frequency at which a response is obtained i.e. for which the blocking limit is not met.

#### Test conditions and measurement method

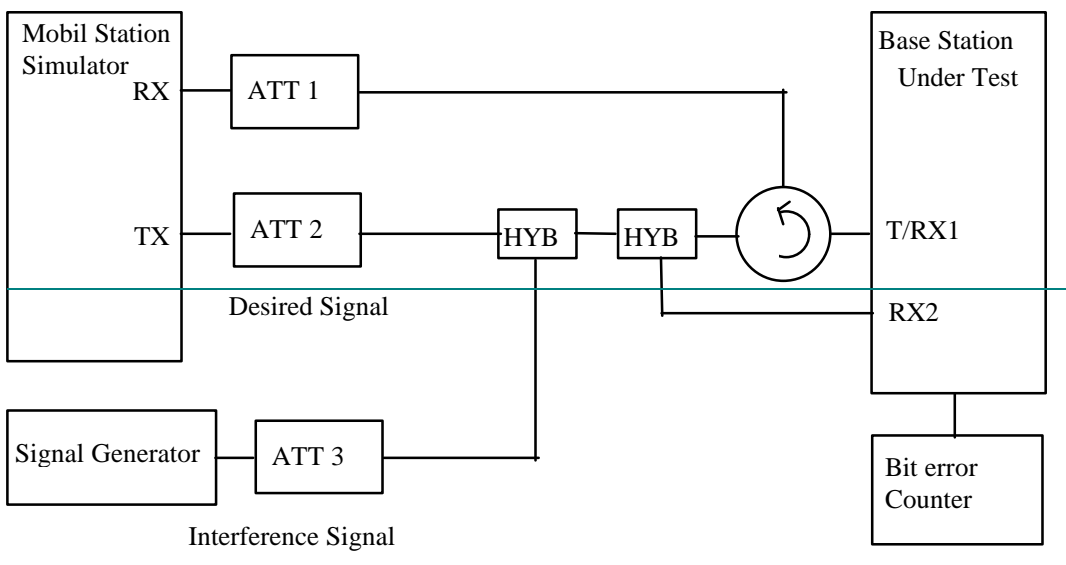

Fig. 7.6-1 Measuring system Setup for Spurious Response

(+) Connect the BS to a mobile station simulator and a Signal generator.



- ~~(2) Disable Transmitter power control (TPC) function.~~
- ~~(3) Adjust the mobile station simulator to a level 6dB above the specified required reference sensitivity level.~~
- ~~(4) Adjust the Signal generator level to the appropriate level for the BS type under test.~~
- ~~(5) The signal generator shall now be swept over the specified frequency band with a defined increment.~~
- ~~(6) The BS shall satisfy the  $[1 \times 10^{-3} \text{ BER}]$  requirement for all signal generator frequencies above.~~
- ~~(7) The requirement shall be met for all information rates and services specified for the BS.~~

## Minimum requirement

The static reference performance as specified in clause 7.2 should be met ~~with a wanted and an interfering signal coupled to BS antenna input using the following parameters. when the following signals are applied to the receiver;~~

*Table 7.6-1 spurious response*

<u>Center Frequency of Interfering Signal</u>	<u>Wanted Signal Level</u>	<u>Interfering Signal Level</u>	<u>Type of Interfering Signal</u>
<u>&lt;1920, 1980 MHz&gt;</u>	<u>&lt;REFSENS&gt; + 6 dB</u>	<u>-40 dBm</u>	<u>CW signal</u>

- ~~—A wanted signal at the assigned channel frequency, 3 dB above the static reference level.~~
- ~~—A CW interfering signal below a level of  $[-42]$  dBm.~~
- ~~—The number of allowed spurious responses is an item for further study.~~

## **7.87.6 Intermodulation characteristics**

Third and higher order mixing of the two interfering RF signals can produce an interfering signal in the band of the desired channel. Intermodulation response rejection is a measure of the capability of the receiver to receiver a wanted signal on its assigned channel frequency in the presence of two or more interfering signals which have a specific frequency relationship to the wanted signal.

The static reference performance as specified in clause 7.2 as should be met when the following signals are applied to the receiver;

- A wanted signal at the assigned channel frequency, 3 dB above the static reference level.
- A CW interfering signal at frequency  $[10 \text{ MHz}]$  and a  $[CW]$  signal at frequency  $[20.1 \text{ MHz}]$  with a level of  $[ ]$  dBm.

## 7.8.17.6.1 Test conditions and measurement method

### (a) Measuring system diagram

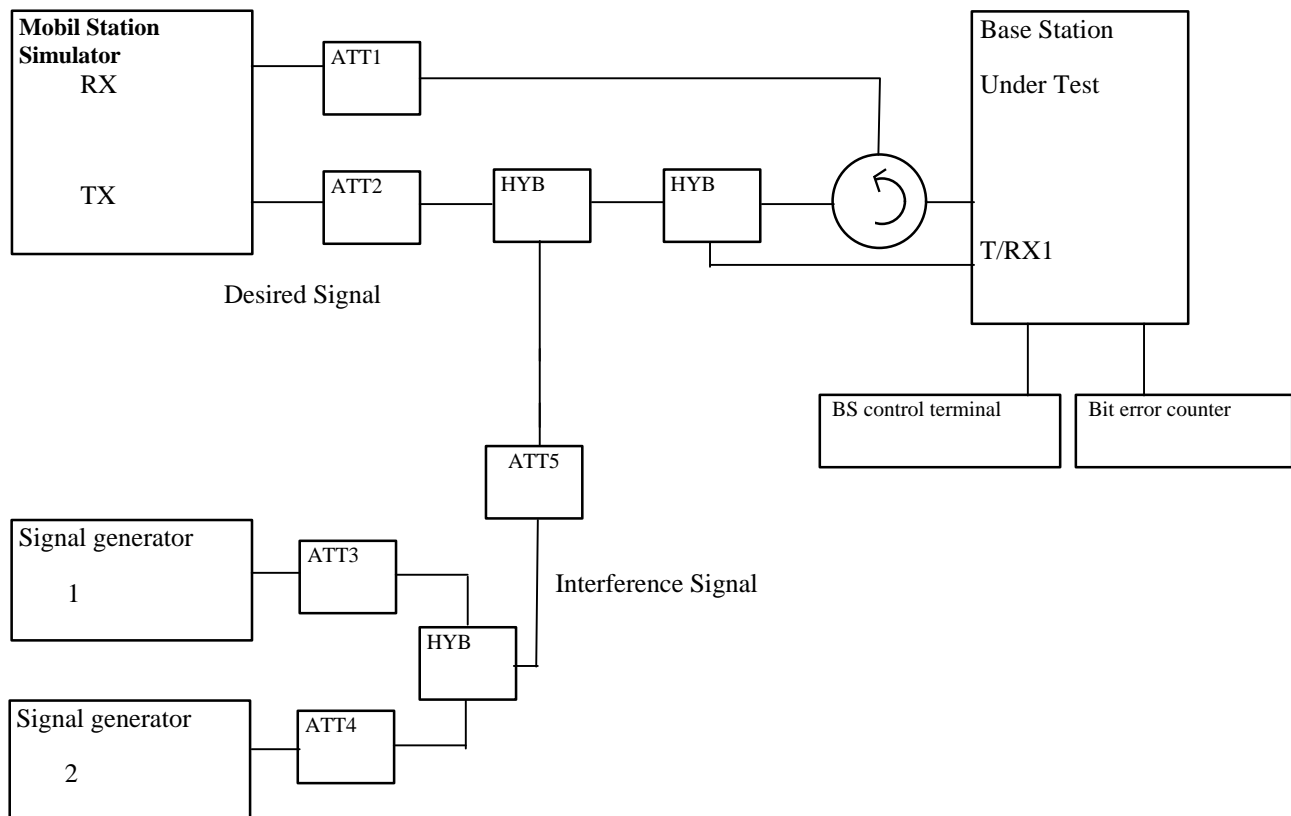

Fig. 7.6-17.8-17.8-1 Measuring system Setup for Reception Intermodulation sensitivity

### (b) Measurement method

- 1) Connect the BTS to a mobile station simulator and a Signal generator.
- 2) Transmitter power control(TPC) is disabled.\*
- 3) Transmit a PN signal from the UE simulator with a level 3dB higher than the minimum required sensitivity level. (refer to 6.1.2.2)
- 4) Adjust the Signal generators to frequency offsets of [+10\*\*] MHz and [+20.1\*\*] MHz from the assigned WCDMA channel.
- 5) Adjust the power of the Signal generators to the absolute value specified for the base station type.
- 6) Measure the BER of the base station.
- 7) Confirm that the BER of the base station receiver is less than  $1 \times 10^{-3}$ .
- 8) The requirement shall be met for all information rates and services specified for the BS.
- 9) Repeat the measurement for frequency offsets [-10\*\*] MHz and [-20.1\*\*] MHz.

\* Necessity and method of closed loop measurement is for future study.

\*\* These values are working assumption for the 5MHz carrier spacing.

## **7.9** ~~Spurious emissions~~

<Text to be added.>

## 8 Performance requirement

### 8.1 General

Performance requirements are specified for a number of test environments and multi-path channel classes.

### 8.2 BS Dynamic reference sensitivity performance

The minimum required dynamic reference sensitivity performance is specified according to the traffic rate and the propagation conditions.

#### 8.2.1 Performance in AWGN channel

The performance requirement in AWGN channel is determined by the  $E_b/I_0$  required for BLER less than [FFS]. The BER is calculated for each of the possible data services.

##### 8.2.1.1 Single link performance

The required  $E_b/I_0$  is described in Table 8.2-1.

Table 8.2-~~18.2-1~~ Performance in AWGN channel

Data services (BLER)	Data rates (kbps)	Required $E_b/I_0$	Performance
Speech	12.2	T.B.D.	BLER shall not exceed [FFS]
Long Constrained Delay data bearer services	64	T.B.D.	BLER shall not exceed [FFS]
	144	T.B.D.	
	384	T.B.D.	
	2048	T.B.D.	
Unconstrained Delay Data bearer services	64	T.B.D.	BLER shall not exceed [FFS]
	144	T.B.D.	
	384	T.B.D.	
	2048	T.B.D.	

Note: Data rates which are supported by the equipment under test shall be tested.

#### 8.2.2 Performance in multipath fading channels

The performance requirement of reverse link with/without TPC in multipath fading channels is determined by the  $E_b/I_0$  required for  $BER=10^{-3}$ ,  $10^{-6}$ . The BER is calculated for each of the possible data services.

##### 8.2.2.1 Single link performance

##### 8.2.2.2 Performance without TPC

The required  $E_b/I_0$  is described in Table 8.2-3.

Table 8.2-3 ~~8.2-2~~  $E_b/I_0$  required for  $BER=10^{-3}, 10^{-6}$ 

Data services (BER)	Indoor (A), 3km/h		Pedestrian (A), 3km/h		Vehicular (A), 120km/h	
	Data rates	Required $E_b/I_0$	Data rates	Required $E_b/I_0$	Data rates	Required $E_b/I_0$
Speech ( $10^{-3}$ )	8kbps	T.B.D.	8kbps	T.B.D.	8kbps	T.B.D.
Long Constrained Delay data bearer services ( $10^{-6}$ )	64kbps	T.B.D.	64kbps	T.B.D.	64kbps	T.B.D.
	2048kbps	T.B.D.	384kbps	T.B.D.	144kbps 384kbps	T.B.D. T.B.D.
Unconstrained Delay Data bearer services ( $10^{-6}$ )	64kbps	T.B.D.	64kbps	T.B.D.	64kbps	T.B.D.
	2048kbps	T.B.D.	384kbps	T.B.D.	144kbps 384kbps	T.B.D. T.B.D.

### 8.2.2.3 Performance with TPC

The required  $E_b/I_0$  is described in Table 8.2-5.

Table 8.2-5 ~~8.2-3~~  $E_b/I_0$  required for  $BER=10^{-3}, 10^{-6}$ 

Data services (BER)	Indoor (A), 3km/h		Pedestrian (A), 3km/h		Vehicular (A), 120km/h	
	Data rates	Required $E_b/I_0$	Data rates	Required $E_b/I_0$	Data rates	Required $E_b/I_0$
Speech ( $10^{-3}$ )	8kbps	T.B.D.	8kbps	T.B.D.	8kbps	T.B.D.
Long Constrained Delay data bearer services ( $10^{-6}$ )	64kbps	T.B.D.	64kbps	T.B.D.	64kbps	T.B.D.
	2048kbps	T.B.D.	384kbps	T.B.D.	144kbps 384kbps	T.B.D. T.B.D.
Unconstrained Delay Data bearer services ( $10^{-6}$ )	64kbps	T.B.D.	64kbps	T.B.D.	64kbps	T.B.D.
	2048kbps	T.B.D.	384kbps	T.B.D.	144kbps 384kbps	T.B.D. T.B.D.

### 8.2.2.4 Uplink power control

[The uplink power control test ensures that the power control bits have the correct sense, position, delay, and amplitude.]

### 8.2.2.5 Softer handover performance

[Further study]

### ~~8.2.2.6 Soft handover performance~~

[Further study]

---

## Annex

### A.1 Detailed definition of error events

1) Frame Erasure Ratio (FER):

The frame is defined as erased if the error detection functions using Cyclic Redundancy Check (CRC) in layer 1.

2) Residual Bit Error Ratio (RBER):

The RBER is defined as the residual Bit Error Ratio (BER) in frames, which have not been declared as erased.

3) Bit Error Ratio (BER):

The BER is the overall Bit Error Ratio (BER) independent of frame erasures or when erased frames are not defined.

## Annex BA (Informative): Open items

#	Section	Section description	Current status	Remarks
1	2	References	Shall be filled in later.	Some are added. (May not exhaustive)
2	3.1	Definitions	To be filled in later.	Some are added. (May not exhaustive)
3	3.2	Symbols	To be properly defined later.	Editorial. Shall be filled in later if needed
4	4.1	<del>Acceptable uncertainty of measurement equipment</del>	<del>Just remove the “Editor’s note” is enough?</del>	<del>If the current description in general manner is enough, just remove the Editor’s note. (In case, enumerating for certain items are needed, they will be added.)</del>
5	4.11	<del>Inter-BS synchronous operation</del>	<del>Since TS25.141 is mainly for the specification of radio related part, this section seems to be removed.</del>	<del>Add text and delete Editor’s note.</del>
6	4.12	<del>Selection of configurations for testing</del>	<del>{Editor’s note: To be revised later.}</del>	<del>Not revised so far. But this Editor’s note can be removed since the contents seems to have proper description.</del>
7	4.13	<del>BTS Configurations</del>	<del>Sub-clauses shall be describes later.</del>	<del>Add Text* for 4.13.1 and Remove Editor’s note. *: Proposed text is taken from section 4.10.1 of [4].</del>
8	4.13.2	<del>Duplexers</del>	<del>Shall be revised later.</del>	<del>Revising references to the relevant sections.</del>
9	4.13.4	<del>Ancillary RF amplifiers</del>	<del>Need some further description.</del>	<del>Add Text* for this section. *: Proposed text is taken from section 4.10.4 of [4].</del>
10	4.13.5	<del>BSS using antenna arrays</del>	<del>Title only. Further contribution is expected.</del>	<del>Add Text* for 4.13.5 and Remove Editor’s note. *: Proposed text is taken from section 4.10.5 of [4].</del>
11	5	<del>Format and interpretation of tests</del>	<del>Description needed.</del>	<del>Add Text* for this section. *: Text is taken from section 4.10.5 of [4].</del>
12	6.2.1	Base station maximum output power	Table 6.2.-1 and Table 6.2-2 should be filled in.	Remove Editor’s note, since measuring the total power is enough.  (Working assumption for power ratio for each channel shall be taken from AH1-DL discussion in Aug.30.)

13	6.3	Frequency stability	Test conditions shall be revised properly.	Adding draft text for it. Q.1: Should Signal to be measured be modulated? Q2: If it is the case, what kind of channel structure defined? Q3: Are there any need to definiene "Frequency measuring equipment" as a "wide-bande frequency counter"?
14	6.5.2	Power control steps	There are some TBD parameters in the test conditions.	Revise description. Q1: How to measure a particular DPCH shall be sprcified. Q2: By what method (can spectrum analyzer do this?) shall be specified.
15	6.5.2.2	Minimum requirement	- Step size torelance is ffs. To define the transmitter power as "code domain power" is ffs.	
16	6.5.3	Power control dynamic range	There are some TBD parameters in the test conditions.	
17	6.5.4	Minimum transmit power	There are some TBD parameters in the test conditions.	
18	6.5.5	Total power dynamic range	There are some TBD parameters in the test conditions.	
19	6.5.6	Power control cycles per second	There are some TBD parameters in the test conditions.	
20	6.6	Transmitted RF carrier power versus time	Table 6.5-1 should be filled in.	
21	6.6.4	Perch channel power	There are some TBD parameters in the test conditions.	
22	6.7.1	Occupied bandwidth	Texts for measurement method are needed. Table 6.6-1 should be filled in.	
23	6.7.3	Spurious emissions	There are some TBD parameters in the test conditions. Table 6.6-3 and Table 6.6-4 should be filled in.	
24	6.8	Transmit intermodulation	There are some TBD parameters in the test conditions. Further input for co-located cellular systems are needed.	
25	7	Receiver characteristics	<del>Definition of requirements for antenna diversity is ffs. Definitions of test channels is required.</del>	Adding text. Remove 1 <sup>st</sup> Editor's note on requirement on antenna diversity. Baseline is taken from section 7 in [4]. Measurement channel shall be specified in Annex. (AH01-UL)
26	7.2.1	Test conditions and measurement methods	<del>BER and UER measurement method should be defined.</del>	Add description in Annex A. Baseline text is taken from Annex A in [4].



27	7.2.2	Minimum requirement	<Editor: Should only be specified for a measurement channel.>	(Shall be defined in Annex.)
28	4.5		The need for such a requirement is ffs.	Delete this section. There is no specification in [1].
29	7.3	Dynamic range	<del>Channel type is ffs. The effect of applying LNAs to the dynamic range specification is ffs.</del>	Stay ffs. Align with [1]. Delete Note. Since same note in [1] has been removed.
30	7.4	Adjacent Channel Selectivity (ACS)	Title only. Further studies are needed.	Add description. Baseline text is taken from section 6.1.2.4 of [5]. Minimum requirement is taken from section 7.5.1 of [1].
31	7.5	Blocking characteristics	The definition of the exemptions needs to be reconsidered, since it seems unclear.	Add description. Baseline text is taken from section 6.1.2.6 of [5]. Minimum requirement is taken from section 7.7 of [1].  (Further precise description with Spurious response seems to be needed.)
32	7.6	Spurious response	There are some blank parameters in the test conditions.	Add description. Baseline text is taken from section 6.1.2.6 of [5]. Minimum requirement is taken from section 7.7 of [1].
33	7.8	Spurious emissions	Text to be added.	(Can be removed?)
34	8.2.1	Performance in AWGN channel	<ul style="list-style-type: none"> <li>- BER (or FER) measurement method should be defined.</li> <li>- There are some TBD parameters in Table 8.2-1</li> </ul>	Add description in Annex-A. Baseline text is taken from Annex A in [4]. ( Table 8.2.1 still requires further study.)
35	8.2.2.4[6.4.1.3]	Uplink power control	Text for this section is needed.	
36	8.2.2.5[6.4.1.4]	Soft handover performance	FFS.	
37	[6.4.1.5]	Soft handover performance	<del>Duplicate to the prior section. Simple deletion is enough.</del>	Delete the section.
38	8.2.2.2	Performance without TPC	There are some TBD parameters in the table.	
39	8.2.2.3	Performance with TPC	There are some TBD parameters in the table.	
40	[6.4.1.3]	Uplink power control	<del>Duplicate to the prior section. Simple deletion is enough.</del>	Delete the section.
41	[6.4.1.4]	Soft handover performance	(Already deleted.)	
42	[6.4.1.5]	Soft handover performance	(Already deleted.)	
43	General	e.g. BS vs. BSS	Terminology should be in line with other specifications	(Editor will take care.)

44	6.2.1.1	Test Conditions and measurement method	Which part of the code shall be measured should be specified.	
45	6.5.2.1	Test conditions and measurement method	<Editor's note: In whichh symbol rate, should measurement done shall be specified.>	
46	6.5.2.1	Test conditions and measurement method	<Editor's note: In whichh symbol rate, should measurement done shall be specified.>	
47	6.5.3.1	Test conditions and measurement method	<Editor's note: In whichh symbol rate, should measurement done shall be specified.>	
48	6.5.4.1	Test conditions and measurement method	<Editor's note: In whichh symbol rate, should measurement done shall be specified.>	
49	6.5.5.1	Test conditions and measurement method	<Editor's note: In whichh symbol rate, should measurement done shall be specified.>	
50	6.5.6.1	Test conditions and measurement method	<Editor's note: In whichh symbol rate, should measurement done shall be specified.>	
51	6.4	Clock Frequency accuracy	Conformance requirement for it is F.F.S.	





## History

Document history		
V0.0.0	28.Mar. 1999	1 <sup>st</sup> draft
TS 25.141 V0.1.0	22 April 1999	Noted by TSG-RAN as TS 25.141 V0.1.0
V0.1.1	27 May 1999	Updated according to decision agreed at 3GPP TSG RAN WG4 meeting #4, Stockholm, May 10-12, with some small editorial changes.
V0.1.2	14 June 1999	Section title, order are rearranged to be in line with TS25.104
V0.1.3	16 June 1999	Section number is renumbered. Some editorial rearrangement, such as changing page boundaries, correction of style etc., are made.
V1.0.0	17 June 1999	Document status raised to revision V1.0.0 at TSG RAN#4. No technical or editorial content changes from previous version, only version is raised.
V1.0.1	28 June 1999	Further editorial changes, such as renumbering of figure and table numbers, are made. Section 4.1 is revised according to the proposed text in Tdoc.R4(99)348.
V1.0.2	2 July 1999	Section 6.5 through 6.7 are revised according to the proposed text in Tdoc.R4(99)335. Annex-A (Open issues) is subjoined, but it has no contents yet.
V1.0.3	19 July 1999	Removing “[ ]” from description in section 6.3.2, 6.4.2.2, 6.4.3.2, 6.4.4.2, 6.6.2.2.2, 6.6.2.3.1, 6.6.3.1, 6.8.1.2, Section 6.4.2, 6.6.1, are also revised. These changes are made in order to keep in line with TS25.104(v2.1.0).
V1.0.4	22 Aug. 1999	<p>Section 4.1 is revised by proposed text in Tdoc.R4(99)375.</p> <p>Section 8.2.1 is revised by proposed text in Tdoc.R4(99)374 with modification of changing BER to BLER.</p> <p>Open issues presented in Tdoc.R4(99)411 are merged into Annex-A. Also, issues in 6.2.1.1 is added.</p> <p>Section for “Clock frequency accuracy” is inserted as section 4.6 to reflect proposal by Tdoc.R4(99)405. Conformance requirement for it is FFS and this status is reflected to Annex-A (Open issues).</p> <p>Editorial changes:</p> <p>Section 2.(References): List is added.</p> <p>Table and figure number s are re-numbered again.</p> <p>Add Table 6.8-1, since it is referred by the text body.</p> <p>In Section 6.5.6, TPC control step is corrected from 1.6kHz to 1.5kHz. In section 6.6.2, and 6.7.2.2.1, RBW is corrected as 3.84MHz.</p> <p>Duplicated part just after seciton 8.2.1.1 are removed. They appear just after seciton 8.2.2.3 again.</p> <p>Name of each channels are corrected. (such as BCCH1,2 to PCCPCH etc.)</p>

V2.0.0	24 Sep. 1999	<p>General discription part (Sec.1 – Sec. 5) are revised according to the proposed way in Tdoc. R4(99) 556.</p> <p>Section 6.2.1 and Section 6.5.2 are revised according to the proposed way in Tdoc. R4(99) 557.</p> <p>Section 5.3 is revised according to the proposed way in Tdoc. R4(99) 558.</p> <p>From sec. 7 to the last section are revised according to the proposed way in Tdoc. R4(99) 559.</p> <p>Section for “Spurious response” is removed since related section in TS25.104 was agreed to remove in RAN4#7 meeting. (Tdoc. R4(99)476).</p> <p>Editorial changes:</p> <p>Section 2.(References): TS25.113 is subjoined.</p> <p>Add “Remarks” column to Open item table in Annex-A.</p>
<p>Editor for TS 25.141 (Base station conformance testing(FDD) is:</p> <p>Takaharu Nakamura</p> <p>FUJITSU LABORATORIES</p> <p>Tel: +81 468 47 5421</p> <p>Fax: +81 468 47 5424</p> <p>Email: <a href="mailto:poco@flab.fujitsu.co.jp">poco@flab.fujitsu.co.jp</a></p> <p>This document is written in Microsoft Word 98</p>		