

Technical Specification Group, Radio Access Network
Miami, USA, June 17-18,1999

TSGR#4(99)342

Agenda Item: 6.3

Source: Editor

Title: UMTS 25.423 UTRAN Iur Interface RNSAP Signalling v1.1.1

Document for: Information

3GPP

Note : Revision marks reflect changes since version 1.0.2, i.e. the corrections agreed when approving the version 1.0.2 at RAN WG3#4 as well as changes due to decisions made at the RAN WG3 meeting #4. The latter changes are thus not approved yet by RAN WG3.

Note: This document shall also include an annex showing the document status. This annex is under preparation.

3GPP

TS 25.~~413~~423 V1.~~10~~12 (1999-065)

Technical Specification

**3rd Generation Partnership Project (3GPP);
Technical Specification Group (TSG) RAN**

UTRAN Iur Interface RNSAP Signalling

[UMTS 25.~~413~~423]

3GPP



Reference

<Workitem> (<Shortfilename>.PDF)

Keywords

<keyword[, keyword]>

3GPP

Postal address

Office address

Internet

secretariat@3gpp.org
Individual copies of this deliverable
can be downloaded from
<http://www.3gpp.org>

Copyright Notification

No part may be reproduced except as authorized by written permission.
The copyright and the foregoing restriction extend to reproduction in all media.

©
All rights reserved.

Contents

Intellectual Property Rights	8
Foreword	8
1 Scope.....	8
2 References	8
3 Definitions, Symbols and Abbreviations	8
3.1 Definitions	8
3.2 Symbols	9
3.3 Abbreviations.....	9
4 General.....	9
5 RNSAP Services	10
5.1 RNSAP Procedure Modules	10
5.2 Parallel Transactions.....	10
6 Services Expected from Signalling Transport	10
7 Functions of RNSAP	10
8 RNSAP Procedures.....	11
8.1 Basic Mobility Procedures.....	11
8.1.1 Uplink SignallingTransfer	11
8.1.2 Downlink SignallingTransfer	12
8.1.3 SRNS Relocation Commit.....	12
8.1.4 URA Paging Request	13
8.2 DCH procedures	13
8.2.1 Radio Link Setup.....	13
8.2.2 Radio Link Addition.....	15
8.2.3 Radio Link Deletion.....	16
8.2.4 Radio Link Reconfiguration (synchronised).....	17
8.2.5 Radio Link Reconfiguration (unsynchronised).....	19
Physical Channel Reconfiguration.....	20
8.2.7 Radio Link Failure	21
8.2.8 Radio Link Load Indication	22
8.2.9 Radio Measurements Reporting	22
8.2.10 Down Link Power Control	23
8.3 Common Transport Channel Procedures	23
8.3.1 C-RNTI Release	23
8.3.2 Common Transport Channel Initialisation	24
8.4 Common Procedures.....	24
8.4.1 Load Information Request.....	24
8.4.2 Load Information	25
9 Elements for RNSAP Communication	26
9.1 Message Functional Definition and Content.....	26
9.1.1 Message Contents.....	26
9.1.2 RADIO LINK SETUP REQUEST	27
9.1.3 RADIO LINK SETUP RESPONSE.....	28
9.1.4 RADIO LINK SETUP FAILURE.....	29
9.1.5 RADIO LINK ADDITION	30
9.1.6 RADIO LINK ADDITION RESPONSE	30
9.1.7 RADIO LINK ADDITION FAILURE.....	31
9.1.8 RADIO LINK DELETION	32
9.1.9 RADIO LINK DELETION RESPONSE	32
9.1.10 RADIO LINK RECONFIGURATION PREPARE.....	32
9.1.11 RADIO LINK RECONFIGURATION READY	33
9.1.12 RADIO LINK RECONFIGURATION COMMIT.....	33

9.1.13	RADIO LINK RECONFIGURATION FAILURE	34
9.1.14	RADIO LINK RECONFIGURATION CANCEL	34
9.1.15	RADIO LINK RECONFIGURATION	34
9.1.16	RADIO LINK RECONFIGURATION RESPONSE	35
9.1.17	RADIO LINK FAILURE	35
9.1.18	DOWNLINK POWER CONTROL	36
	PHYSICAL CHANNEL RECONFIGURATION REQUEST	36
	PHYSICAL CHANNEL RECONFIGURATION COMMAND	36
	PHYSICAL CHANNEL RECONFIGURATION FAILURE	37
9.1.22	UPLINK SIGNALLING TRANSFER	37
9.1.23	DOWNLINK SIGNALLING TRANSFER	37
9.1.24	SRNS RELOCATION COMMIT	37
9.1.25	URA PAGING REQUEST	38
9.1.26	MEASUREMENT REPORT	38
9.1.27	C-RNTI RELEASE	38
9.1.28	LOAD INFORMATION REQUEST	39
9.1.29	LOAD INFORMATION	39
9.1.30	COMMON TRANSPORT CHANNEL REQUEST	39
9.1.31	COMMON TRANSPORT CHANNEL RESPONSE	39
9.1.32	RADIO LINK LOAD INDICATION	39
9.2	Information Element Functional Definition and Contents	40
9.2.1	Binding ID	42
9.2.2	Cause	42
9.2.3	Cell ID	43
9.2.4	CFN	43
9.2.5	Channelisation Code	43
9.2.6	Channelisation Code Length	44
9.2.7	Chip Offset	44
9.2.8	CRNC Address	44
9.2.9	C-RNTI	44
9.2.10	C-RNTI Release Indication	44
9.2.11	DCH ID	44
9.2.12	DCH QoS	44
9.2.13	DCH Type	44
9.2.14	Diversity Control Field	44
9.2.15	Diversity Indication	44
9.2.16	DL Channelisation Code ID	44
9.2.17	DL Channelisation Code Type	44
9.2.18	DL Reference Power	44
9.2.19	DL Scrambling Code	45
9.2.20	Execution Time	45
9.2.21	Information Transfer Capability	45
9.2.22	Initial DL Power	45
9.2.23	Maximum Uplink Eb/No (FFS)	45
9.2.24	Message Type	45
9.2.25	Minimum Uplink Eb/No (FFS)	46
9.2.26	Neighbor Cell Information	46
9.2.27	No. of DCHs	46
9.2.28	No. of DL Channelisation Code	46
9.2.29	No. of Radio Links	46
9.2.30	No. of UL Channelisation Code	46
9.2.31	OFF	46
9.2.32	Old RNTI	46
9.2.33	Old URA ID	46
9.2.34	Perch Channel Ec/Io	46
9.2.35	Phase Difference	47
9.2.36	Primary CCPCH Scrambling Code	47
9.2.37	Radio Frequency	47
9.2.38	Reference RL ID	47
9.2.39	RL ID	47

9.2.40	SGSN Signalling Address (FFS).....	47
9.2.41	Slot Offset	47
9.2.42	Soft Combination Indicator	47
9.2.43	S-RNTI.....	47
9.2.44	Target UL Eb/I0	47
9.2.45	Transaction ID.....	47
9.2.46	Transport Address.....	47
9.2.47	Transport Format Combination Set.....	48
9.2.48	Transport Format Set.....	48
9.2.49	UARFN	48
9.2.50	UL Channelisation Code ID	48
9.2.51	UL Channelisation Code Type	48
9.2.52	UL Eb/No Target	48
9.2.53	UL Interference Level	48
9.2.54	UL Scrambling Code.....	48
L3 Information.....		48
9.3	Message and Information element abstract syntax (with ASN.1)	48
9.4	Message transfer syntax	48
9.5	Timers.....	48
10	Handling of Unknown, Unforeseen and Erroneous Protocol Data	49
11	Annex A (normative):.....	49
12	History	50

Intellectual Property Rights

Foreword

This Technical Specification has been produced by the 3rd Generation Partnership Project, Technical Specification Group RAN.

The contents of this TS may be subject to continuing work within the 3GPP and may change following formal TSG approval. Should the TSG modify the contents of this TS, it will be re-released with an identifying change of release date and an increase in version number as follows:

Version m.t.e

where:

- m indicates [major version number]
- x the second digit is incremented for all changes of substance, i.e. technical enhancements, corrections, updates, etc.
- y the third digit is incremented when editorial only changes have been incorporated into the specification.

Scope

The present document specifies the radio network layer signalling procedures between RNCs in UTRAN.

References

The following documents contain provisions which, through reference in this text, constitute provisions of the present document.

- References are either specific (identified by date of publication, edition number, version number, etc.) or non-specific.
- For a specific reference, subsequent revisions do not apply.
- For a non-specific reference, the latest version applies.
- A non-specific reference to an ETS shall also be taken to refer to later versions published as an EN with the same number.

[1] UMTS 25.931, UTRAN Functions, Examples on Signalling Procedures

[2] UMTS 25.426, UTRAN Iur and Iub Interface Data Transport & Transport Layer Signalling for DCH Data Streams

4 Definitions, Symbols and Abbreviations

Definitions

For the purposes of the present document, the [following] terms and definitions [given in ... and the following] apply.

<defined term>: <definition>.

example: text used to clarify abstract rules by applying them literally.

1.1 Symbols

For the purposes of the present document, the following symbols apply:

<symbol> <Explanation>

1.1 Abbreviations

AAL2	ATM Adaptation Layer type 2
ASN.1	Abstract Syntax Notation One
ATM	Asynchronous Transfer Mode
BCCCH	Broadcast Control Channel
BID	Binding Identity
CCPCH	Common Control Physical Channel
CFN	Connection Frame Number
CN	Core Network
CRNC	Controlling RNC
DCH	Dedicated Channel
DL	Downlink
DRNC	Drift RNC
DRNS	Drift RNS
DRX	???????

[Editor's note:

The abbreviation DRX is undefined. It is only used in one chapter (URA Paging). It needs to be deleted or clarified.
Contributions are invited]

FN	Frame Number
FP	Frame Protocol
MAC	Medium Access Control
PDU	Protocol Data Unit
QoS	Quality of Service
RAB	Radio Access Bearer
RL	Radio Link
RNS	Radio Network Subsystem
RNSAP	Radio Network Subsystem Application Part
RNTI	Radio Network Temporary Identifier
RRC	Radio Resource Control
SRNC	Serving RNC
SRNS	Serving RNS
TFCI	Transport Format Combination Indicator
TFCS	Transport Format Combination Set
TFS	Transport Format Set
UARFCN	UMTS Absolute Radio Frequency Channel Number
UARFN	UMTS Absolute Radio Frequency Number
UE	User Equipment
UL	Uplink
URA	UTRAN Registration Area
UTRAN	UMTS Terrestrial Radio Access Network

1 General

[Editor's note: This chapter should describe requirements on RNSAP forward/backward compatibility, error handling principles, message coding principles etc.]

The sender of an RNSAP message shall include the Source Signalling Address, i.e. the Signalling Address of the sending node.

The issue of the transport layer address is FFS.

4 RNSAP Services

The RNSAP offers the following services:

4.1 RNSAP Procedure Modules

The Iur interface RNSAP procedures are divided into ~~three~~four modules as follows:

1. RNSAP Basic Mobility Procedures
2. RNSAP DCH Procedures
3. RNSAP Common Transport Channel Procedures

4. RNSAP Common Procedures

The Basic Procedures module contains procedures used to handle the mobility within UTRAN. If procedures from this module are not used, then the cell level mobility will not be supported between corresponding RNS, and those RNSs are considered to belong to different UTRANs.

The DCH Procedures module contains procedures that are used to handle DCHs between two RNSs. If procedures from this module are not used in a specific Iur, then the usage of DCH traffic between corresponding RNSs is not possible. If this category is supported then the existence of Iur user plane for DCH is also assumed.

The Common Transport Channel Procedures module contains procedures that are used to control common transport channel data streams over Iur interface. If the procedures within this module are not used on a specific Iur, then the common channel data can not be transported between corresponding UTRANs.

The Common Procedures module contains procedures that are not related to a specific UE. The procedures in this module are in contrast to the above modules involving two peer RNCs.

[Editor's note: The description of the last module is the editors proposal, as requested at the RAN WG3 meeting #4 in Warwick. This note is to be deleted at approval of the next version of this specification.]

[Editor's Note:

RNSAP DCH Procedures will be standardised but whether they become mandatory or optional is FFS.

RNSAP Common Transport Channel Procedures will be standardised but whether they become mandatory or optional is FFS.]

Parallel Transactions

There can only be one RNSAP procedure for a specific UE active at one instance of time.

4 Services Expected from Signalling Transport

Functions of RNSAP

The following procedures are included in RNSAP:

Basic Mobility Procedures	Reference
Uplink SignallingTransfer	0
Downlink SignallingTransfer	0
Error! Not a valid link. SRNS Relocation Commit	0
URA Paging Request	0
DCH procedures	
Radio Link Setup	0
Radio Link Addition	0
Radio Link Deletion	0
Radio Link Reconfiguration (synchronised)	0
Radio Link Reconfiguration (unsynchronised)	0
Down Link Code Reconfiguration <u>Physical Channel</u> Reconfiguration	0
Radio Link Failure	0
<u>Radio Link</u> Load Indication	0
Radio Measurements Reporting	0
Down Link Power Control	0
Common Transport Channel Procedures	
C-RNTI Release	0
<u>Common Transport Channel Initialisation</u>	0
<u>Common Procedures</u>	
<u>Load Information Request</u>	0
<u>Load Information</u>	0

4 RNSAP Procedures

[Editor's note: This chapter should list RNSAP procedures, including a text describing the procedure (triggering events, successful and unsuccessful outcome. Message sequences should be provided (using Word pictures for simple editing).

]

4.1 Basic Mobility Procedures

Uplink SignallingTransfer

The Uplink Signalling Transfer message is used to transfer radio interface messages containing s-RNTI and SRNC ID as UE addressing information from the CRNC to the Serving RNC. The message contains the message received L3 Information ~~Uu message~~, S-RNTI, C-RNTI and the Cell-ID (the RRC message reception cell)

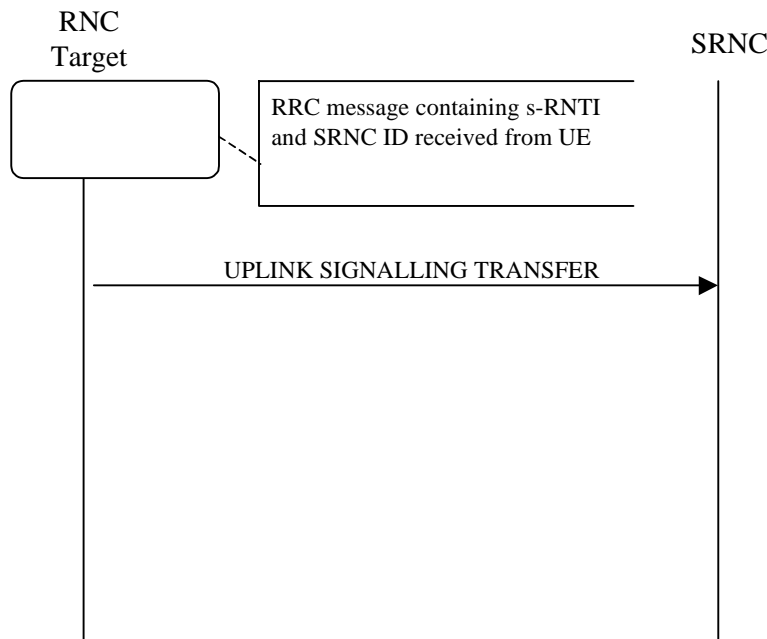

Figure 9-8: An example RNSAP message flow at I_{ur} interface for Uplink Signalling Transfer

Downlink Signalling Transfer

The procedure may be used by the SRNC in response to a received Uplink Signalling Transfer message. ~~The procedure is used in such a case when the SRNC decides not to perform the SRNC relocation procedure towards the DRNC.~~

The procedure consists in the Downlink Signalling Transfer message sent by the SRNC to the DRNC.

The message contains the L3 Information Uu message to be sent to the UE, the Cell ID contained in the Uplink Signalling Transfer message, the C-RNTI and an indication if the C-RNTI shall be released at the reception of the message.

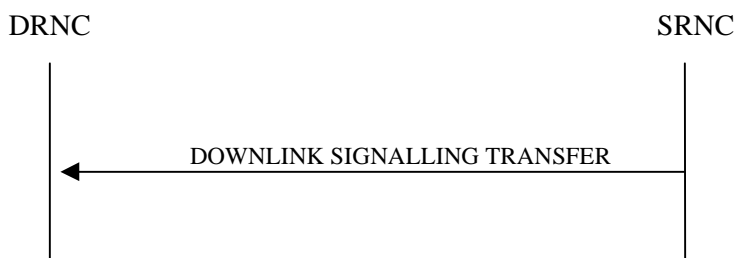

Figure 9-9: An example RNSAP message flow at I_{ur} interface for Downlink Signalling Transfer

SRNS Relocation Commit

The SRNS RELOCATION COMMIT procedure is part of the SRNS Relocation procedure described in [1].

The source RNC sends the SRNS RELOCATION COMMIT message to the target RNC when it has received an indication that it can proceed with the SRNC Relocation procedure from all the involved CN nodes [1].

At reception of the SRNS RELOCATION COMMIT message from the source RNC the target RNC executes the DL and UL switch for all RABs belonging to the UE at the earliest suitable time instance.

Prior to reception of the SRNS RELOCATION COMMIT message the target RNC has received a request to perform SRNS Relocation from all the involved CN nodes and responded to the CN nodes with a proceeding indication. The Iu transport bearers for each radio access bearer have also been established between the target RNC and all CN nodes.



Fig. 9-14: SRNC Relocation Commit

URA Paging Request

This procedure is used by the SRNC to indicate to the Controlling RNC that a UE should be paged in a URA. The UE is identified by its RNTI, and the SRNC indicates in the message the URA identity as well as potential information that may be needed (e.g. DRX parameters).

[Editor's note:

The abbreviation DRX is undefined. It is only used in this chapter. It needs to be deleted or clarified. Contributions are invited]

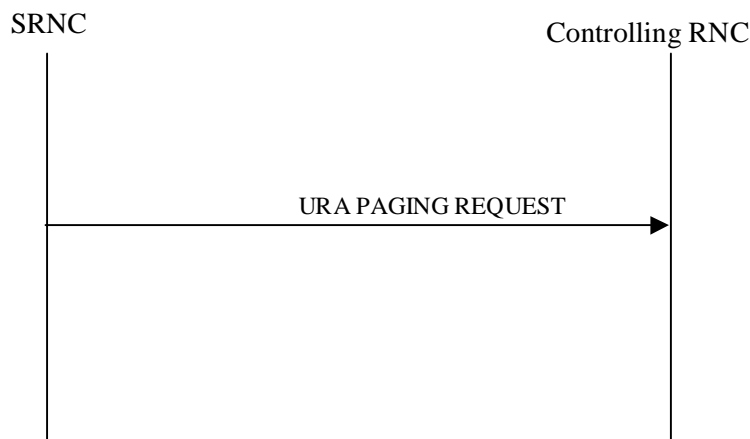

Figure 9-13. URA Paging Request

4.1 DCH procedures

Radio Link Setup

When the serving RNC makes an algorithmic decision to add the first cell or set of cells from another RNS (a drift RNS) to the active set of a specific RRC connection, the RNSAP message RADIO LINK SETUP REQUEST is sent to the corresponding drift RNC to request setup of the radio link(s). This message contains essentially RL identifier(s), the target cell identifier(s), transport format sets (TFSs) for each active DCH and desired radio resources for each radio link. The serving RNC also indicates when several radio links are to be setup in the drift RNS, either that

1. the radio links may be combined by the DRNS, or
2. the radio links must not be combined.

Additional information is FFS.

Since the drift RNS is responsible for its own radio resources the load control (Admission control) must be performed due to the request, In successful case (the load is not too high) the drift RNS allocates requested type of channelisation codes for each RL and assigns a binding identifier and a transmission address (e.g. ATM Address) for each DCH. This information is sent to the serving RNS in the message RADIO LINK SETUP RESPONSE when all the RLs have been successfully setup. The drift RNS also provides the serving RNC with the:

- Cell identity of all neighboring cells to the cell(s) where the radio link(s) is added.
- Information related to neighboring cells necessary for the serving RNS (the exact parameters are FFS), and the Signaling Address of any RNC controlling neighboring cells not controlled by the drift RNS.

Mechanisms to reduce the amount of information to be transported are FFS.

The serving RNC is responsible for setting up the I_{ur} transport bearers for each DCH. The transport bearers are setup towards the address indicated in the RADIO LINK SETUP RESPONSE message from the drift RNC. Also the setup messages should include the corresponding binding identifier, which will be used by the drift RNC to map each transport bearer to the corresponding DCH.

In unsuccessful case (i.e. one or more RLs can not be setup) an RNSAP message RADIO LINK SETUP FAILURE is returned, indicating among other things the reason for failure.

An example of a corresponding message flow at the I_{ur} interface is presented in Figure 9-1.

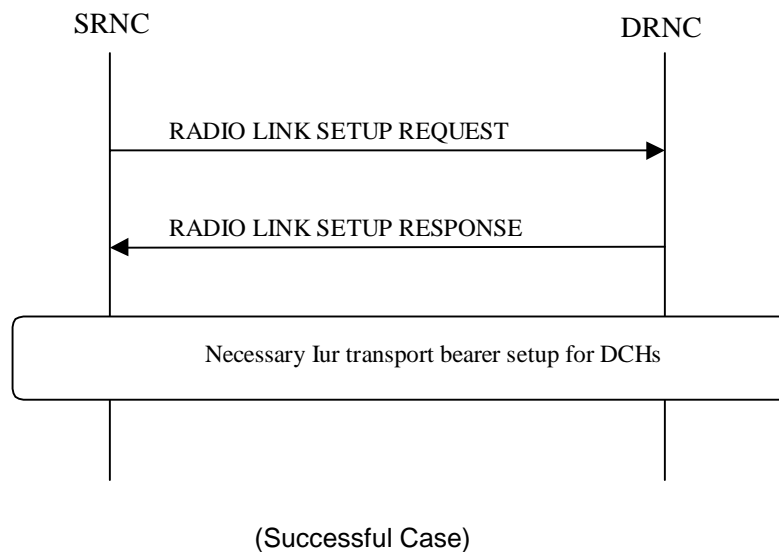

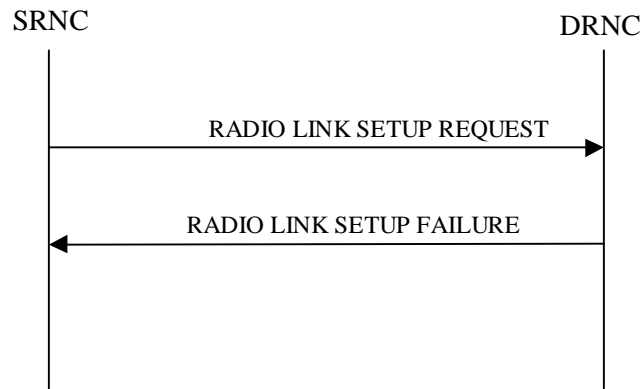

(Unsuccessful Case)

Figure 9-1. An example RNSAP message flow at I_{ur} interface for RL setup.

4.4.4 Radio Link Addition

When the serving RNC makes an algorithmic decision to add an additional cell or set of cells from another RNS (a drift RNS) to the active set of a specific RRC connection, the RNSAP message RADIO LINK ADDITION REQUEST is sent to the corresponding drift RNC to request addition of a radio link. This message contains essentially RL identifier, the target cell identifier, transport format sets (TFSS) for each active DCH and desired radio resources for each radio link. The serving RNC also indicates either that

1. the new radio link may be combined with already existing radio links for this RRC connection, or
2. the new radio link must not be combined with already existing radio links for this RRC connection.

Additional information is ffs.

Since the drift RNS is responsible for its own radio resources the load control (Admission control) must be performed due to the request. In successful case (the load is not too high) the drift RNS allocates requested type of channelisation codes for each RL and assigns a binding identifier and a transmission address (e.g. AAL2 address) for each DCH. The time at which the DRNS allocates the channelisation code is FFS. This information is sent to the Serving RNC in the message RL ADDITION RESPONSE when all RLs have been successfully setup. The drift RNC also provides the SRNC with the:

- Cell Identity of all neighboring cells to the cell(s) where the radio link(s) is added,
- information related to neighboring cells necessary for the SRNC (the exact parameters are FFS), and
- the Signaling Address of any RNC controlling neighboring cells not controlled by the drift RNC

Mechanisms to reduce the amount of information to be transported is FFS.

The serving RNC is responsible for setting up the I_{ur} transport bearers for each DCH. The transport bearers are setup towards the address indicated in the RL ADDITION RESPONSE message from the drift RNC. Also the setup messages should include the corresponding binding identifier, which will be used by the drift RNC to map each transport bearer to the corresponding DCH.

In case the serving RNC has indicated that the new radio link may be combined with already existing radio links for this RRC connection, the drift RNS may instead of assigning binding identifiers and transport addresses in the RL ADDITION RESPONSE message indicate that the already existing I_{ur} transport bearers can be used also for the new radio link. In such a case the response includes the ATM Binding ID of the already existing AAL2 connection. If old transport bearers are used, then the serving RNC does not perform additional transport bearer setups.

In unsuccessful case (i.e. one or more RLs can not be added) an RNSAP message RADIO LINK ADDITION FAILURE is returned, indicating among other things the reason for failure.

An example of a corresponding message flow at I_{ur} interface is presented in figure 9-2.

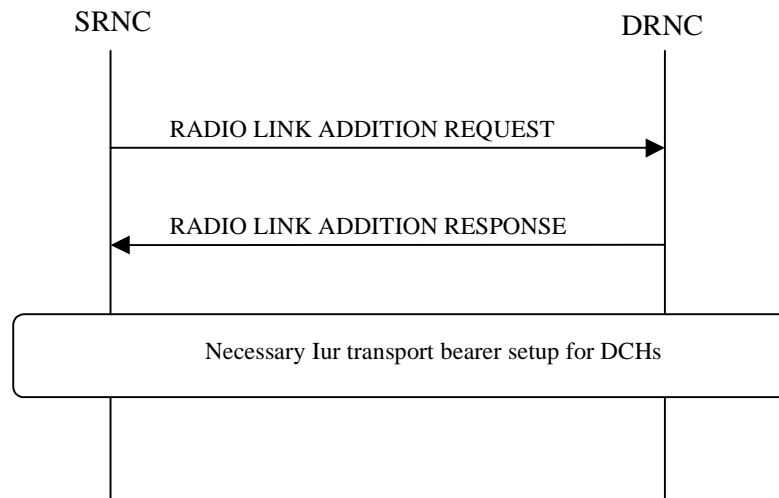

(Successful case)

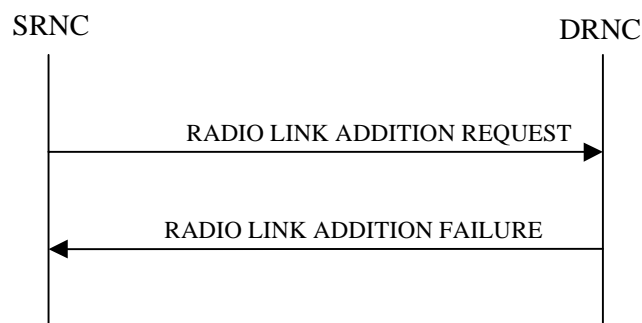

(Unsuccessful case)

Figure 9-2. An example RNSAP protocol message flow at I_{ur} interface for inter RNS RL addition.

4.1.1.1 Radio Link Deletion

When the serving RNC makes an algorithmic decision to delete a cell from another RNS (drift RNS) from the active set of a specific RRC connection, the message RL DELETION to request deletion of radio link is sent to the corresponding drift RNC. The message contains essentially the RL identifier to be deleted. Upon reception of the message, the Drift RNS should immediately delete the radio link and all related allocations within the drift RNS and acknowledge the deletion to the Serving RNC by the message RL DELETION RESPONSE.

The serving RNC is responsible to release the corresponding I_{ur} transport bearers, if they are not used by other radio links.

An example of a corresponding message flow at I_{ur} interface is presented in figure 9-3.

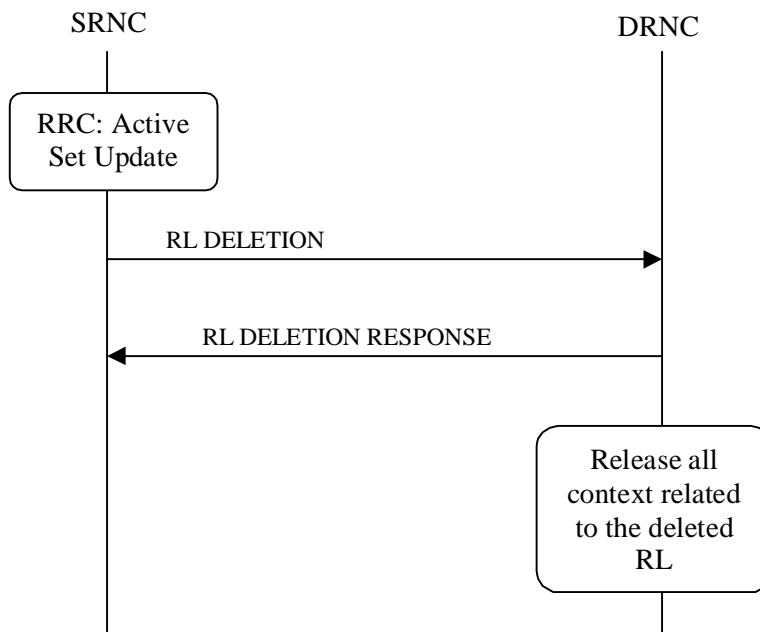

Figure 9-3. An example RNSAP protocol message flow at I_{ur} interface for interRNS RL deletion.

4.1.1.1 Radio Link Reconfiguration (synchronised)

RL Reconfiguration procedure is used to reconfigure radio links related to one UE-UTRAN connection within one DRNS. The procedure can be used to add, delete or modify a DCH, or to perform physical channel reconfiguration.

The RL Reconfiguration procedure is initiated by the serving RNC by sending the RNSAP message RL RECONFIGURATION PREPARE to the DRNC. The message is sent using the relevant signalling connection.

The message includes essentially the desired radio link parameters for the radio links after completion of this procedure. The following parameters can be specified (the list is to be considered as an incomplete example):

Possible parameters related to all radio links after completion of the procedure:

- DL channelisation code type(s)
- New UL channelisation type
- New TFCS
- IDs of the DCHs to be added / deleted or modified
- Priority of the added/modified DCH
- TFS of the added/modified DCH

If the proposed modifications are allowed by the DRNS resource management algorithms, and the DRNC has successfully reserved the required resources it responds to the SRNC with RL RECONFIGURATION READY message.

If the requested reconfiguration fails for one or more RLs the DRNC sends the RNSAP message RL RECONFIGURATION FAILURE to the SRNC, indicating among other things the reason for failure.

The RL RECONFIGURATION READY message contains the downlink channelisation codes for each radio link (if changed), a Binding Identifier (BID) and transmission address (e.g. AAL2 address) for each new Iur transport bearer (if any).

SRNC informs the UE about the changes in radio links (RL) with the relevant RRC message(s) and sends the RL RECONFIGURATION COMMIT message to DRNCs.

SRNC is responsible for releasing unnecessary Iur transport bearers (if any).

Note. A mechanism for synchronising the switch from the old to the new configuration in the UE and the DRNS is needed and FFS.

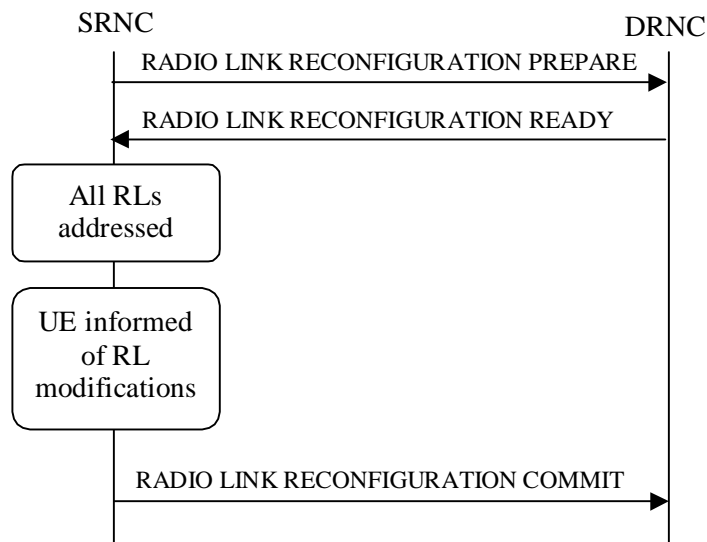

(Successful case)

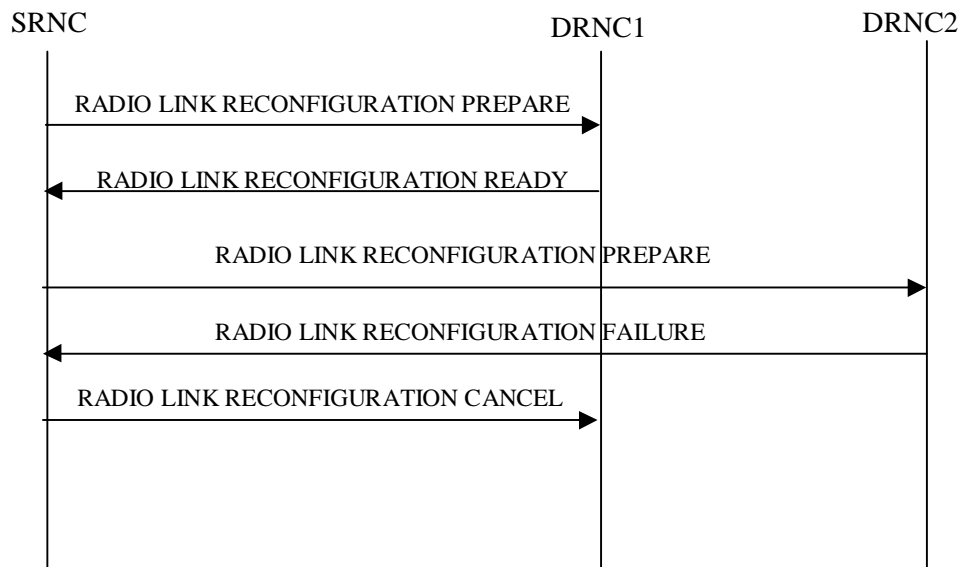

(Unsuccessful case)

Figure 9-4. RL Reconfiguration procedure (synchronised)

4.1.1 Radio Link Reconfiguration (unsynchronised)

RL Reconfiguration procedure is used to reconfigure radio links related to one UE-UTRAN connection within one DRNS. The procedure can be used to add, delete or modify a DCH or to perform transport channel reconfiguration.

The Unsynchronised RL Reconfiguration is used when there is no need to synchronise the time of the switching from the old to the new configuration in the NodeBs used by the UE-UTRAN connection. This is the case when new TFCs are added or old TFCs are deleted without changing the TFCI values of the TFCs that are maintained during the reconfiguration.

The RL Reconfiguration procedure (unsynchronised) is initiated by the serving RNC by sending the RNSAP message RL RECONFIGURATION to the DRNC. The message is sent using the relevant signalling connection.

The message includes essentially the desired radio link parameters for the radio links after completion of this procedure. The following parameters can be specified (the list is to be considered as an incomplete example):

Possible parameters related to all radio links after completion of the procedure:

- New TFCs
- IDs of the DCHs to be added / deleted or modified
- Priority of the added/modified DCH
- TFS of the added/modified DCH

If the proposed modifications are allowed by the DRNS resource management algorithms, and the DRNC has successfully reserved the required resources it responds to the SRNC with RL RECONFIGURATION RESPONSE message.

If the requested reconfiguration fails for one or more RLs the DRNC sends the RNSAP message RL RECONFIGURATION FAILURE to the SRNC, indicating among other things the reason for failure.

The RL RECONFIGURATION RESPONSE message contains the downlink spreading codes for each radio link (if changed), a Binding Identifier (BID) and transmission address (e.g. AAL2 address) for each new Iur transport bearer (if any).

SRNC is responsible for releasing unnecessary Iur transport bearers (if any).

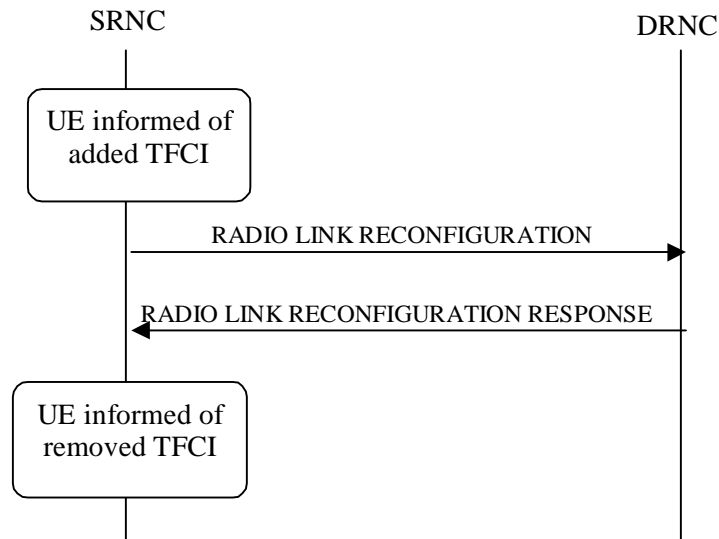

Figure 9-5. RL Reconfiguration procedure (unsynchronised)

Down Link Code Physical Channel Reconfiguration

[Editor's note: The description of this procedure does not match the changes to the message PHYSICAL CHANNEL RECONFIGURATION REQUEST agreed at the RAN WG3 meeting #4 in Warwick.]

DL Code Reconfiguration is used to change the DL channelisation codes of radio link(s) related to one UE-UTRAN connection. The spreading factor can not be changed and this procedure is used only to defragment the DL channelisation code pool.

Code reconfiguration procedure is initiated by the DRNS, when it detects unwanted fragmentation in the DL channelisation code pool(s). DRNC sends ~~DL-CODE~~PHYSICAL CHANNEL RECONFIGURATION REQUEST to the SRNC via the appropriate dedicated connection. The message includes the radio link ID(s) and proposal for the new DL channelisation codes for them.

SRNC decides appropriate execution time for the change. SRNC sends relevant RRC message(s) to the UE and RNSAP PHYSICAL CHANNEL, DL-CODE RECONFIGURATION COMMAND to the DRNS.

DRNS makes the switch to the new codes and releases the old DL channelisation codes.

If the SRNC can not accept the DL code reconfiguration request it will send the PHYSICAL CHANNEL, DL-CODE RECONFIGURATION FAILURE message to the DRNS.

If the DRNC receives RL RECONFIGURATION PREPARE, RL RECONFIGURATION or RL DELETION it should also be interpreted as a DL code reconfiguration failure. These messages thus override the DRNC request for ~~DL~~physical channel reconfiguration.

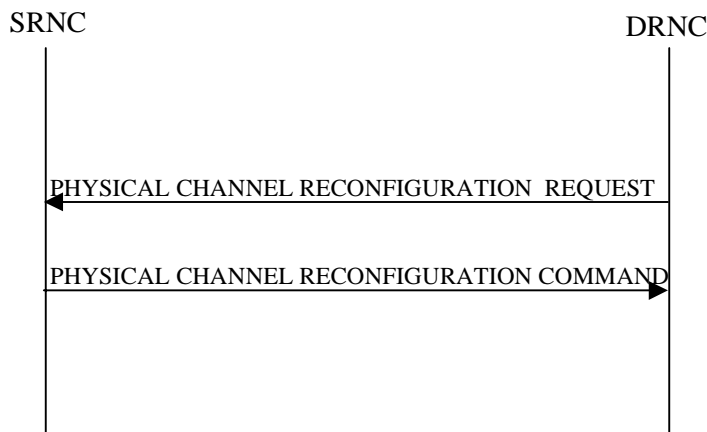

Figure 9-6. ~~DL Code~~Physical Channel Reconfiguration procedure

1.1.1 Radio Link Failure

This procedure is started by the drift RNS when a radio link is no longer available. The reasons for this is a DRNS internal failure or congestion (in the RNC or in the Node B or in the interfaces) or lost radio interface synchronisation due to bad radio condition. Other reasons are FFS.

As consequence the DRNC sends the RNSAP message RL FAILURE to the SRNC. The message is sent using the relevant signalling connection.

The message specifies at least:

- RL ID(s): The message may address all the radio links of the drift RNC
- A reason code for the release (ex: cell congestion, hardware failures, etc.)

At reception of the RL FAILURE the SRNC could perform the following actions:

- Inform the UE that the radio link has to be removed.
- Perform relevant procedures (RL Deletion) in order to release all the resources allocated in the DRNS to the removed RL(s), including the transmission resources on the Iur interface.

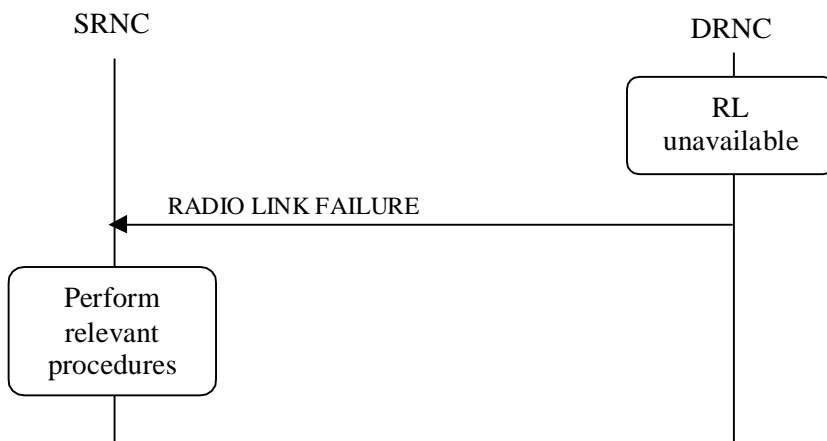

Figure 9-11. RL Failure procedure

Whether this procedure can also be used to notify dropping of DCH(s) is FFS.

4.1.1 Radio Link Load Indication

[Editor's note: First paragraph of this chapter is added by the editor, based on Tdoc SMG2 UMTS-ARC 145/98. Minor editorial changes has been made to the bulleted list].

Load Indication procedure is triggered by the Drift RNS. It is used to indicate to the Serving RNC about the necessity to modify some DCH parameters within the Drift RNS.

Whether or not to include this procedure in the Radio Measurement Reporting procedure is FFS.

~~Although the subsequent actions of the SRNC after the Load Indication procedure are out of the scope of this contribution, following examples can be assumed to be carried out by the SRNC.~~

- ~~• DCH modification procedure~~
- ~~• Ignoring the command,~~
- ~~• Performing an handover,~~
- ~~• Radio link deletion procedure~~
- ~~• Triggering the renegotiation of the bearer quality of service~~
- ~~• Release the bearer~~

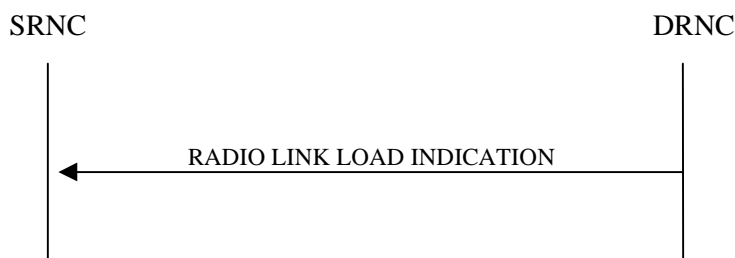

Figure 9-x: An example RNSAP message flow at I_{ur} interface for Radio Link Load Indication.

4.1.1 Radio Measurements Reporting

This procedure is used by the DRNC to report its radio measurements to the SRNC.

When the measurement reporting criteria are met, the DRNC send the RNSAP MEASUREMENT REPORT message to the SRNC using the dedicated signalling bearer connection. The message includes at least the used downlink power.

The reporting criteria are set with the RL Setup procedure.



Figure 9-12. Radio Measurements Reporting

~~Note. It is FFS whether the reporting is done in the u-plane (inband) or in the e-plane (RNSAP).~~

4.1.4 Down Link Power Control

~~[Editor's note: This procedure is FFS. Study item Iur/1 from TTC/ARIB-ETSI merging: Out band or in band Power Control (both UL and DL).]~~

The purpose of this procedure is to balance the DL transmission powers of the radio links used for the related RRC connection within the NodeB. The DL POWER CONTROL procedure is initiated by the Serving RNC by sending a DL POWER CONTROL message to the DRNC, which contains the desired downlink reference power ~~range~~ for the radio links within the NodeB of the DRNS.



Figure 9-15: DL POWER CONTROL Procedure.

~~[Editor's note: This procedure is deleted in accordance with decision on the study item Iur/1 from TTC/ARIB-ETSI merging: Out band or in band Power Control (both UL and DL). The decision to use inband signalling for this procedure was taken based on the Study Item Report R3-99xxx. This note is to be deleted once this version of the specification is removed]~~

4.1 Common Transport Channel Procedures

C-RNTI Release

This procedure is used by the SRNC to request release of the Common Transport Channel Traffic Context Identity for a given UE in the DRNS.

SRNC initiates the C-RNTI Release procedure in order to indicate that the C-RNTI can be released from the DRNC. SRNC sends the message C-RNTI RELEASE to the DRNC. The message contains the C-RNTI of the UE whose context shall be released.

At the reception of the message, the DRNC releases the C-RNTI used by the UE.



Figure 9-17: C-RNTI Release Request

Common Transport Channel Initialisation

Common Transport Channel Request procedure is used by the SRNC for the initialisation of the Common Transport Channel user plane towards the DRNC and /or for the initialisation of the UE context in the DRNC. The procedure is triggered by SRNC as consequence of a received Uplink Signalling Transfer message in case there is a need for such initialisation.

The procedure consists of the message COMMON TRANSPORT CHANNEL REQUEST from the SRNC to the DRNC, and COMMON TRANSPORT CHANNEL RESPONSE from DRNC to SRNC. The need for a COMMON TRANSPORT CHANNEL FAILURE is FFS.

[Editor's note: The procedure and the messages may have to be renamed.]

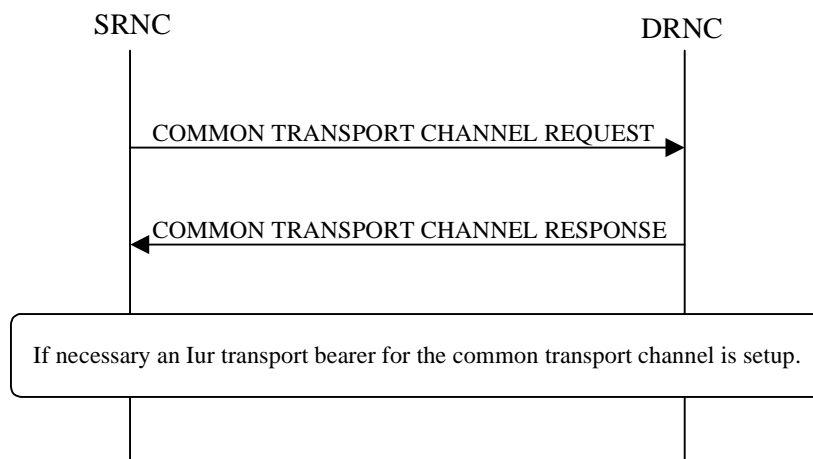

Figure 9-x. An example RNSAP message flow at I_{ur} interface for Common Transport Channel Initialization.

Common Procedures

Load Information Request

The Load Information Request procedure is used by RNC1 to set in RNC2 the reporting criteria used by the load information procedure towards RNC1. The procedure consists in the message LOAD INFORMATION REQUEST sent by RNC1 to RNC2 using the connectionless service of the signalling bearer.

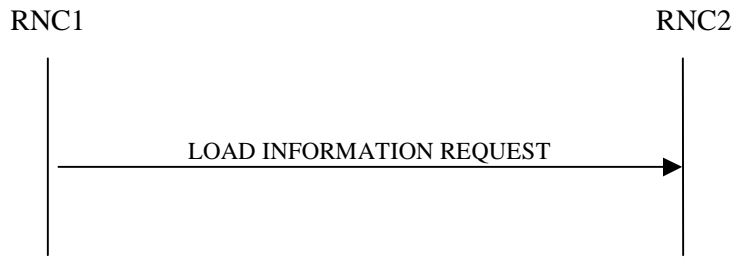

Figure 9-x: An example RNSAP message flow at I_{ur} interface for Load Information Request.

Load Information

With this procedure RNC1 informs RNC2 about the load in one or more cells under its control.

When the load information reporting criteria are met, RNC1 sends to RNC2 the RNSAP LOAD INFORMATION message using the connectionless service of the signalling bearer. This message contains information about the load in one or more cell.

The load information reporting criteria may be defined via O&M or using the Load Information procedure.

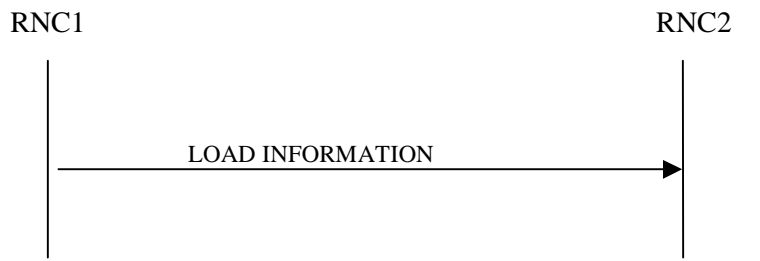

Figure 9-x: An example RNSAP message flow at I_{ur} interface for Load Information.

4 Elements for RNSAP Communication

Message Functional Definition and Content

This chapter defines the structure of the messages required for the RNSAP protocols.

For each message there is, a table listing the signaling elements in their order of appearance in the transmitted message.

All the RNSAP messages are listed in the following table:

Message name	Reference
RADIO LINK SETUP REQUEST	0
RADIO LINK SETUP RESPONSE	0
RADIO LINK SETUP FAILURE	0
RADIO LINK ADDITION	0
RADIO LINK ADDITION RESPONSE	0
RADIO LINK ADDITION FAILURE	0
RADIO LINK DELETION	0
RADIO LINK DELETION RESPONSE	0
RADIO LINK RECONFIGURATION PREPARE	0
RADIO LINK RECONFIGURATION READY	0
RADIO LINK RECONFIGURATION COMMIT	0
RADIO LINK RECONFIGURATION FAILURE	0
RADIO LINK RECONFIGURATION CANCEL	0
RADIO LINK RECONFIGURATION	0
RADIO LINK RECONFIGURATION RESPONSE	0
RADIO LINK FAILURE	0
<u>DOWNLINK</u> POWER CONTROL	0
<u>PHYSICAL CHANNEL</u> DL CODE RECONFIGURATION REQUEST	0
<u>PHYSICAL CHANNEL</u> DL CODE RECONFIGURATION COMMAND	0
<u>PHYSICAL CHANNEL</u> DL CODE RECONFIGURATION FAILURE	0
UPLINK SIGNALLING TRANSFER	0
DOWNLINK SIGNALLING TRANSFER	0
SRNS RELOCATION COMMIT	0
URA PAGING REQUEST	0
MEASUREMENT REPORT	0
C-RNTI RELEASE	0
<u>LOAD INFORMATION REQUEST</u>	0
<u>LOAD INFORMATION</u>	0
<u>COMMON TRANSPORT CHANNEL REQUEST</u>	0
<u>COMMON TRANSPORT CHANNEL RESPONSE</u>	0
<u>RADIO LINK LOAD INDICATION</u>	0

Message Contents

An information element can be of the following *types*:

M	The information element is mandatory, i.e. always present in the message
O	The information element is optional, i.e. may or may not be present in the message independently on the presence or value of other information elements in the same message
C#	The presence of the information element is conditional to the presence or to the value of another information element, as reported in the correspondent note below the message description.

In case of an information element group, the group is preceded by a name for the info group (in bold). It is also indicated whether the group is mandatory, optional or conditional. Each group may be also repeated within one message. The presence field of the information elements inside one group defines if the information element is mandatory, optional or conditional if the group is present.

Note 1: The proposed tables with the message contents do not include the length and direction columns proposed by TTC.

Note 2: The proposed message structure does not include the 'length' and 'compatibility information' parameters that are proposed by TTC, because they will be specified by the formal language.

4.1.1RADIO LINK SETUP REQUEST

Information element	Reference	Type
Message type	0	M
Transaction ID	0	FFSM
S-RNTI	0	M
DCH information		M
DCH ID	0	M
DCH Type	0	M
Transport format set (DL)	0	M
Transport format set (UL)	0	M
TFCS (UL)	0	M
TFCS (DL)	0	M
Uplink scrambling code		M
UL Channelisation Codes		M
Channelisation code length (UL)	0	M
DL Channelisation Codes		M
Channelisation code length (DL)	0	M
RL information		M
RL-ID	0	M
Cell-ID	0	M
OFF	0	M
Chip offset	0	M
Diversity control field	0	C2
Perch channel Ec/Io	0	M
Uplink Eb/No Setpoint Target	0	FFSM
Uplink Eb/No Adjustment parameters	9.2.52	FFS
Maximum Uplink Eb/No	0	FFS
Minimum Uplink Eb/No	0	FFS
DL reference power	0	M

C2=present only if # of RL >1

4.1.1 RADIO LINK SETUP RESPONSE

Information element	Reference	Type
Message type		M
Transaction ID		FFSM
C-RNTI		M
RL information response		M
RL-ID		M
Diversity Indication		C1
Reference RL-ID		C2
DL Scrambling code		M
DL Channelisation Codes		M

DL Channelisation code		M
DCH information response		C3
DCH ID		M
Binding ID		M
Transport Address		FFS
Neighbouring cell information		O
Cell ID		O
CRNC ID		O
UARFCN		M
Primary CCPCH scrambling code		M
Frame Offset		O

C1=present only if # of RL >1

C2=present only if *Diversity Indication* is 'ON'

C3= present only if *Diversity Indication* is 'OFF'

4.1.1 RADIO LINK SETUP FAILURE

Information element	Reference	Type
Message type		M
Transaction ID		FFSM
RL not setup		M
RL ID		M
RL Failure Cause		M
RL information response (RL successfully setup)		O
RL-ID		M
Diversity Indication		C1
Reference RL-ID		C2
DL Scrambling code		M
DL Channelisation Codes		M

DL Channelisation code		M
DCH successfully setup		C3
DCH ID		M
Binding ID		M
Transport Address		O
Neighbouring cell information		O
Cell ID		O
CRNC Address		O
UARFCN		M
Primary CCPCH scrambling code		M
Frame Offset		O

C1=present only if # of RL >1

C2=present only if Diversity Indication is 'ON'

C3= present only if Diversity Indication is 'OFF'

4.1.1.1 RADIO LINK ADDITION

Information element	Reference	Type
Message type		M
Transaction ID		FFSM
RL information		M
RL-ID		M
Cell-ID		M
OFF		M
Chip offset		M
Diversity Control field		M
Perch channel Ec/Io		M
Uplink Eb/No Setpoint Target		FFSM
Uplink Eb/No Adjustment parameters		FFS
Uplink Maximum Eb/No		FFS
Uplink Minimum Eb/No		FFS
DL reference power		O

4.1.1.1 RADIO LINK ADDITION RESPONSE

Information element	Reference	Type
Message type		M
Transaction ID		FFSM
RL information response		M
RL-ID		M
Diversity Indication		M
Reference RL-ID		C1
DL Scrambling code		M
DL Channelisation Codes		M
DL Channelisation code		M
DCH information response		C2
DCH ID		M
Binding ID		M
Transport Address		FFS
Neighbouring cell information		O
Cell ID		M
CRNC Address		O
UARFCN		M
Primary CCPCH scrambling code		M
Frame Offset		O

C1=present only if *Diversity Indication* is 'ON'

C2= present only if *Diversity Indication* is 'OFF'

4.1.4 RADIO LINK ADDITION FAILURE

Information element	Reference	Type
Message type		M
Transaction ID		FFSM
RL not setup		M
RL-ID		M
RL Failure cause		M
RL information response (RL successfully setup)		M
RL-ID		M
Diversity Indication		M
Reference RL-ID		C1
DL Scrambling code		M
DL Channelisation Codes		M
DL Channelisation code		M
DCH information response		C2
DCH ID		M
Binding ID		M
Transport Address		O
Neighbouring cell information		O
Cell ID		M
CRNC Address		O
UARFCN		M
Primary CCPCH scrambling code		M
Frame Offset		O

Note1: The message has the same contents of the RL SETUP FAILURE message, and may be not needed.

4.1.1.4 RADIO LINK DELETION

Information element	Reference	Type
Message type		M
Transaction ID		FFSM
RL to delete		M
RL-ID		M

4.1.1.4 RADIO LINK DELETION RESPONSE

Information element	Reference	Type
Message type		M
Transaction ID		FFSM

4.1.1.4 RADIO LINK RECONFIGURATION PREPARE

Information element	Reference	Type
Message type		M
Transaction ID		FFSM
DCHs to modify		O
DCH ID		M
DCH Type		O
Transport format set (DL)		O
Transport format set (UL)		O
DCHs to add		O
DCH ID		M
DCH Type		M
Transport format set (DL)		M
Transport format set (UL)		M
DCHs to delete		O
DCH ID		M
TFCS (DL)		M
TFCS (UL)		M
Uplink Scrambling code		O
UL Channelisation Codes		O
Channelisation code (UL)		M
DL Channelisation Codes		O
Channelisation code length (DL)		M
Uplink Eb/No Setpoint		FFS
Uplink Eb/No Adjustment parameters		FFS
Uplink Maximum Eb/No		FFS
Uplink Minimum Eb/No		FFS
DL reference power		FFS

4.1.1.1 RADIO LINK RECONFIGURATION READY

Information element	Reference	Type
Message type		M
Transaction ID		FFSM
RLs to be reconfigured (synch)		O
RL ID		M
Channelisation Codes (DL)		O
Channelisation code (DL)		M
DCH to be setup		O
DCH ID		M
Binding ID		M
Transport Address		FFS

4.1.1.1 RADIO LINK RECONFIGURATION COMMIT

Information element	Reference	Type
Message type		M
Transaction ID		FFSM
CFN		M

4.1.1.1 RADIO LINK RECONFIGURATION FAILURE

Information element	Reference	Type
Message type		M
Transaction ID		FFSM
Cause1		M
RLs not reconfigured		O
RL ID		M
Cause2		M

4.1.1.1 RADIO LINK RECONFIGURATION CANCEL

Information element	Reference	Type
Message type		M
Transaction ID		FFSM

4.1.1.1 RADIO LINK RECONFIGURATION

Information element	Reference	Type
Message type		M
Transaction ID		FFSM
DCHs to modify		O
DCH ID		M
DCH Type		O
Transport format set (DL)		O
Transport format set (UL)		O
DCHs to add		O
DCH ID		M
DCH Type		M
Transport format set (DL)		M
Transport format set (UL)		M
DCHs to delete		O
DCH ID		M
TFCS (DL)		O
TFCS (UL)		O
Uplink Eb/No Setpoint		FFS
Uplink Eb/No Adjustment parameters		FFS
Uplink Maximum Eb/No		FFS
Uplink Minimum Eb/No		FFS
DL reference power		O

4.1.1.1 RADIO LINK RECONFIGURATION RESPONSE

Information element	Reference	Type
Message type		M
Transaction ID		FFSM
RLs to be reconfigured (unsynch)		O
RL ID		M
DCHs to be setup		M
DCH ID		M
Binding ID		M
Transport Address		FFS

4.1.1.1 RADIO LINK FAILURE

Information element	Reference	Type
Message type		M
Transaction ID		FFSM
RLs Unavailable		M
RL ID		M
Cause for RL failure		M

4.1.4 DOWNLINK POWER CONTROL

[Editor's note:

The contents this chapters has partly not been agreed. This is left from the merging of the TTC/ARIB and ETSI documentation. The content (except DL Reference Power) is FFS. Contributions are invited.]

Information element	Reference	Type
Message identifier <u>type</u>		M
<u>Transaction ID</u>		<u>M</u>
Length		M
Message Compatibility Information		M
DL <u>Reference</u> Power- Range		M

4.1.2 ~~DL CODE~~ PHYSICAL CHANNEL RECONFIGURATION REQUEST

Information element	Reference	Type
Message type		M
Transaction ID		FFSM
RL ID		M
<u>FDD Physical Channel Information</u> DL channelisation Codes		<u>MC1</u>
Channelisation code (DL)		M
<u>TDD Physical Channel Information</u>		<u>C1</u>
<u>User Code</u>		<u>M</u>
<u>UL Time Slot</u>		<u>M</u>
<u>DL Time Slot</u>		<u>M</u>

C1= either the FDD Physical Channel Information or the TDD Physical Channel Information is included in the message.

4.1.3 ~~DL CODE~~ PHYSICAL CHANNEL RECONFIGURATION COMMAND

Information element	Reference	Type
Message type		M
Transaction ID		FFSM
CFN		M

4.1.4 DL CODE PHYSICAL CHANNEL RECONFIGURATION FAILURE

Information element	Reference	Type
Message type		M
Transaction ID		M
Cause		FFS

4.1.5 UPLINK SIGNALLING TRANSFER

Information element	Reference	Type
Message type		M
<u>Transaction ID</u>		<u>M</u>
Cell-ID		M
C-RNTI		M
S-RNTI		M
<u>L3 Information</u> Uu message		M
SGSN Signalling Address		M (see Editor's note)

[Editor's note:

The parameter "SGSN Signalling Address" is dependent on the solution of the addressing principles to be received from 3GPP TSG SA WG2. The existence of the parameter is thus FFS.]

4.1.6 DOWNLINK SIGNALLING TRANSFER

Information element	Reference	Type
Message type		M
<u>Transaction ID</u>		<u>M</u>
Cell ID		M
C-RNTI		M
Uu message <u>L3 Information</u>		M
C-RNTI Release indication		M

4.1.7 SRNS RELOCATION COMMIT

[Editor's note:

This message has no content described due to lack of contributions. Contributions are invited.]

<u>Information element</u>	<u>Reference</u>	<u>Type</u>
<u>Message type</u>		<u>M</u>
<u>Transaction ID</u>		<u>M</u>

--	--	--

4.1.8 URA PAGING REQUEST

[Editor's note:

This message has no content described due to lack of contributions. Contributions are invited.]

<u>Information element</u>	<u>Reference</u>	<u>Type</u>
<u>Message type</u>		<u>M</u>
<u>Transaction ID</u>		<u>M</u>

4.1.9 MEASUREMENT REPORT

[Editor's note:

This message has no content described due to lack of contributions. Contributions are invited.]

<u>Information element</u>	<u>Reference</u>	<u>Type</u>
<u>Message type</u>		<u>M</u>
<u>Transaction ID</u>		<u>M</u>

4.1.10 C-RNTI RELEASE

<u>Information element</u>	<u>Reference</u>	<u>Type</u>
Message type		M
<u>Transaction ID</u>		<u>M</u>
C-RNTI		M

LOAD INFORMATION REQUEST

[Editor's note:

This message has no content described due to lack of contributions. Contributions are invited.]

<u>Information element</u>	<u>Reference</u>	<u>Type</u>
<u>Message type</u>		<u>M</u>
<u>Transaction ID</u>		<u>M</u>

LOAD INFORMATION

[Editor's note:

This message has no content described due to lack of contributions. Contributions are invited.]

<u>Information element</u>	<u>Reference</u>	<u>Type</u>
<u>Message type</u>		<u>M</u>
<u>Transaction ID</u>		<u>M</u>

COMMON TRANSPORT CHANNEL REQUEST

[Editor's note:

This message has no content described due to lack of contributions. Contributions are invited.]

<u>Information element</u>	<u>Reference</u>	<u>Type</u>
<u>Message type</u>		<u>M</u>
<u>Transaction ID</u>		<u>M</u>

COMMON TRANSPORT CHANNEL RESPONSE

[Editor's note:

This message has no content described due to lack of contributions. Contributions are invited.]

<u>Information element</u>	<u>Reference</u>	<u>Type</u>
<u>Message type</u>		<u>M</u>
<u>Transaction ID</u>		<u>M</u>

RADIO LINK LOAD INDICATION

[Editor's note:

This message has no content described due to lack of contributions. Contributions are invited.]

<u>Information element</u>	<u>Reference</u>	<u>Type</u>
<u>Message type</u>		<u>M</u>

<u>Transaction ID</u>		<u>M</u>

Information Element Functional Definition and Contents

[Editor's note: The contents of this chapter related to encoding of parameters is FFS. It has not been agreed between ETSI and TTC/ARIB. Study item Iu/7 from TTC/ARIB-ETSI merging: It has been decided to use ASN.1 to specify the messages and parameters. However, the encoding (transfer syntax) is still FFS.]

This paragraph contains the CODING of the signaling elements used.

The following convention are assigned for the sequence of transmission of bits and bytes:

Each bit position is marked as 1 to 8. Bit 1 is the least significant bit and is transmitted first.

In an element octets are identified by number, octet 1 is transmitted first, then octet 2 etc.

Length Indicator

It is desirable to have Length for messages and parameters because future version of protocol may have extension to the present message or parameter, and also variable size can be present in some parameters as well.

In case of message size exceeding 256 byte it is better to have 2 bytes for message LENGTH.

However it is enough to have 1 byte for parameter LENGTH.

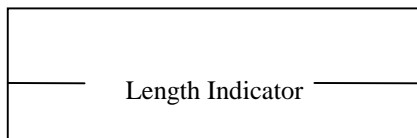

Fig. 3.2.2-2 Length Indicator for Parameter

Fig. 3.2.2-1 Length Indicator for Message

Compatibility Information

Compatibility Information is used in the situation of unrecognized messages or parameter. This parameter should be placed at a certain place then it is easy to pick up this parameter in any circumstances.

Consequently, the format can be as follow:

Message Identifier / Length / Compatibility Info / parameters

Parameter Identifier / Length / Compatibility Info / Fields

Figure 3 shows the coding format of message and Figure 4 shows the coding format of parameter.

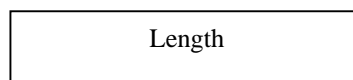
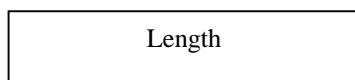
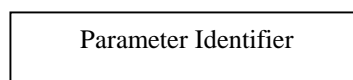
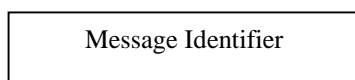

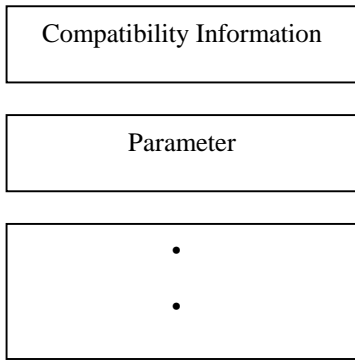

Fig. 3.2.2-3 Message Coding Format

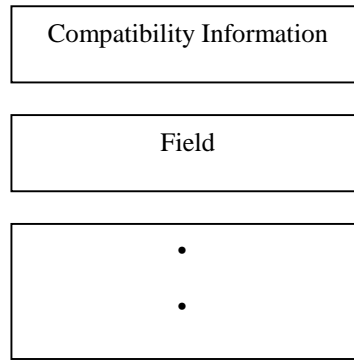

Fig. 3.2.2-4 Parameter Coding Format

Fixed size data and Variable size data in Field

It may have two types of field i.e. with variable size or fixed size in data of field. It has no any problem to specify the fixed size field. Figure5 shows an example of fixed size data in field.

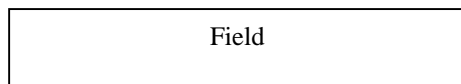

Fig. 3.2.2-5 Format for fixed size field

Regarding the variable size of data

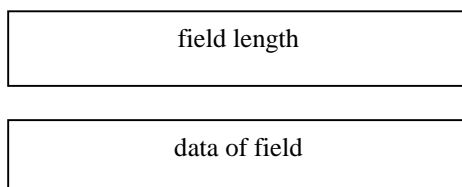

Fig. 3.2.2-6 Length method

The elements used and their CODING are:

Element Identifier Coding	Element name	Reference
	ATM Binding ID	
	ATM Address	
	No of DCHs	
	DCH ID	
	TFS(for DCH)	
	TFCS(for DCHs)	
	Radio Frequency	
	UL scrambling code	
	UL channelisation code type	
	No. of UL channelisation code	
	UL channelisation code ID	

	UL Interference Level	
	DL channelisation code type	
	No. of DL channelisation code	
	DL channelisation code id	
	Cell Id	
	Neighbor Cell Information	
	Soft Combination Indication	
	Phase Difference	
	Radio Link ID	
	No. of Radio Links	
	Execution Time	
	Slot offset	
	Frame offset	
	Initial DL Power	
	DL Power Range	
	Target UL Eb/lo	
	Old RNTI	
	Old URA ID	
	DCH QoS	

Binding ID

Binding ID is an identifier for an user data stream. The Binding ID is allocated by the Drift RNC and it should be unique among all active transport bearers to/from the related drift RNC.

Cause

This element is used to indicate the reason for a particular event to have occurred and is coded as shown below.

The cause value is a single octet element if the extension bit (bit 8) is set to 0. If it is set to 1 then the cause value is a 2octet field.

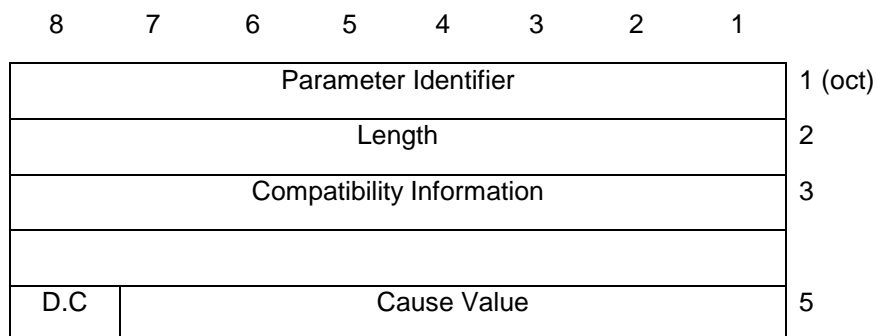

Fig.3.2.2.7 format of Cause

Cause Value:

Class : Normal event

Class:Normal event

Class:Resource unavailable

Class : Service or option not available

Class : Service or option not implemented

Class : invalid message (eg parameter out of range)

Class : protocol error

Class : interworking

The following table shows example of cause value.

Table3.2.2.7 cause value

Cause Value		
Class	value	
<u>765</u>	<u>4321</u>	
		Normal termination Mobile illegal (ex. Authentication NG) O & M intervention Equipment failure Protocol error Message type non-existent or not implemented Information element/parameter non-existent or not implemented Radio link failure BS approach link failure Timer expired Ciphering algorithm not supported Resource unavailable Other values are reserved

Cell ID

Cell ID is an identifier for a cell. A cell is associated to one BCCH. A cell may have different DL scrambling codes, or use different DL scrambling code offsets.

CFN

Connection Frame Number, included in the DCH FP frame. Node B maps the CFN with the cell FN via the Frame offset.

Channelisation Code

Channelisation code can be defined e.g. by indicating the level and branch in the code tree.

Channelisation Code Length

Channelisation code length defines the level of the related channelisation code in the channelisation code tree.

Chip Offset

Defines the radio timing offset inside a radio frame. The precision is at chip level.

CRNC Address

Address of the CRNC. The exact definition is FFS.

C-RNTI

C-RNTI is the UE context identifier in the DRNC. It is unique in the DRNC and it is released when the UE is not using anymore resources in that DRNS.

C-RNTI Release Indication

The C-RNTI Release Indication indicates whether or not a CRNC can release the C-RNTI being allocated for a particular UE.

DCH ID

DCH ID is an identifier for an active dedicated transport channel. DCH ID should be unique for each active DCH among the active DCHs simultaneously allocated for the same UE.

DCH QoS

DCH Type

Defines a priority level of the transport channel.

Diversity Control Field

Indicates if the RL may, must not (or must, FFS) be combined with the others.

Diversity Indication

Indicates if the RL has been (ON) or has been not (OFF) combined with another RL.

DL Channelisation Code ID

DL Channelisation Code Type

~~9.2.18 DL Power Range~~

~~This Information element defines the DL transmission power range to be used for the radio links used for the related RRC connection in the node-Bs within the Drift RNC.~~

~~9.2.19 DL Reference Power~~

Reference transmission power which is used by the fast downlink closed loop power control to eliminate the power drifting problem.

9.2.20 DL Scrambling Code

DL scrambling code to be used by the RL. One cell may have multiple DL scrambling codes available.

9.2.21 Execution Time

9.2.22 Information Transfer Capability

This element is included Information Transfer Capability which has been requested by the UE.

[Note: The following should be described the coding format.(The detail is FFS.)]

9.2.23 Initial DL Power

9.2.24 Maximum Uplink Eb/No (FFS)

Indicate the maximum allowed Eb/No to be used by the UL inner loop power control.

9.2.25 Message Type

Message Type uniquely identifies the message being sent. It is a single octet element, mandatory in all messages.

8765 4321	
	RADIO LINK SETUP RADIO LINK SETUP RESPONSE RADIO LINK SETUP FAILURE
	RADIO LINK ADDITION RADIO LINK ADDITION RESPONSE RADIO LINK ADDITION FAILURE
	RADIO LINK DELETION RADIO LINK DELETION RESPONSE
	RADIO LINK RECONFIGURATION PREPARE RADIO LINK RECONFIGURATION READY RADIO LINK RECONFIGURATION COMMIT RADIO LINK RECONFIGURATION FAILURE RADIO LINK RECONFIGURATION CANCEL RADIO LINK RECONFIGURATION RADIO LINK RECONFIGURATION RESPONSE
	RADIO LINK FAILURE
	DL POWER CONTROL
	UPLINK SIGNALLING TRANSFER DOWNLINK SIGNALLING TRANSFER SRNS RELOCATION COMMIT URA PAGING REQUEST MEASUREMENT REPORT C-RNTI RELEASE
	DL CODE RECONFIGURATION REQUEST DL CODE RECONFIGURATION COMMAND DL CODE RECONFIGURATION FAILURE

Message Compatibility Information

Message Compatibility Information is used in the situation of unrecognized messages.



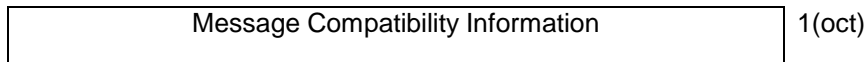

Fig.3.2.2.2 Message Compatibility Information

Table 3.2.2.2 Message Compatibility Information octet

Bit	
8	Reserved
:	
4	Pass On not possible
3	Discard Message
2	Send Notify (1)
1	Release Indicator

9.2.26 Minimum Uplink Eb/No (FFS)

Indicate the maximum allowed Eb/No to be used by the UL inner loop power control.

9.2.27 Neighbor Cell Information

9.2.28 No .of DCHs

9.2.29 No. of DL Channelisation Code

9.2.30 No. of Radio Links

9.2.31 No. of UL Channelisation Code

9.2.32 OFF

OFF (Frame offset) is the desired offset between dedicated channel downlink transmission frames (CFN, connection frame number) and the broadcast channel frame offset (cell frame number). The frame offset value is UE and cell specific.

9.2.33 Old RNTI

9.2.34 Old URA ID

9.2.35 Perch Channel Ec/Io

Signal-to-interference ratio per chip of the perch channel measured by the terminal. The name shall be aligned with WG1&2.

~~9.2.36~~Phase Difference

~~9.2.37~~Primary CCPCH Scrambling Code

Defines the scrambling code used by the cell to broadcast the BCCH.

~~9.2.38~~Radio Frequency

~~9.2.39~~Reference RL ID

ID of the RL which the RL in question has been combined with.

~~9.2.40~~RL ID

RL ID is an identifier for the corresponding Radio Link for one UE. RL ID is allocated by the serving RNC during the branch allocation, and it should be stored both to the serving- and drift RNCs as long as the said RL exists. RL ID can be used later as a reference to the said RL between the serving- and the drift RNC. RL ID should be unique for each active RL among the active RLs simultaneously allocated for the same UE.

~~9.2.41~~SGSN Signalling Address (FFS)

The SGSN Signalling Address indicates the signalling address of an SGSN directly connected to a particular RNC. The existence of this parameter is FFS.

~~9.2.42~~Slot Offset

~~9.2.43~~Soft Combination Indicator

~~9.2.44~~S-RNTI

S-RNTI is the UE context identifier in the SRNC. It is allocated by the SRNC and maintained for all the time the RRC connection is terminating in the SRNC.

~~9.2.45~~Target UL Eb/I0

~~9.2.46~~Transaction ID (FFS)

[Editor's note: The existence of this parameter has been agreed. However, the description may have to be improved to reflect the agreed purpose. Contributions are invited.]

Transaction ID is a unique identifier among all the messages having the same message type and which are sent using the same RNSAP signalling bearer connection. The identifier must be unique among those messages that are in pending state, i.e. messages that can still be references to in a forthcoming message. Transaction Id for complete-, proceeding-, acknowledge- and confirm-type of messages is the same transaction ID that was used in the message for which the above mentioned type message is related to. FFS.

~~9.2.47~~Transport Address

Defines the transport address of the DRNC. For details on the Transport Address used see [2]. The addressing in UTRAN is FFS.

~~9.2.48~~ Transport Format Combination Set

The Transport Format Combinations Set defines the allowed combinations of the transport formats of the transport channels.

~~9.2.49~~ Transport Format Set

Transport format set is a set of transport formats allocated for a DCH. Each transport format defines one combination of parameters that describes 1) the format of the MAC PDU to be transmitted over Iur 2) The procedures that should be done at layer 1 for the MAC-PDUs upon reception.

~~9.2.50~~UARFN

The UTRAN Absolute Radio Frequency Number defines the carrier.

~~9.2.51~~UL Channelisation Code ID

~~9.2.52~~UL Channelisation Code Type

~~9.2.53~~UL Eb/No Adjustment Parameters (FFS)

~~Indicates the steps to be used to increase or decrease the Eb/No setpoint for the outer loop power control. The increase/decrease commands are carried by the FP.~~

~~9.2.54~~UL Eb/No Setpoint Target (FFS)

Indicates the UL Eb/No target to be used by the UL closed loop power control.

~~9.2.55~~UL Interference Level

~~9.2.56~~UL Scrambling Code

Uplink scrambling code is the scrambling code that is used by the UE.

~~9.2.57~~Uu Message L3 Information

This parameter contains [the Layer 3 Information from](#) a Uu message as received from the UE over the Uu interface or [the Layer 3 Information for](#) a Uu message to be sent to a UE by the CRNC.

Message and Information element abstract syntax (with ASN.1)

Editor's note:

ASN.1 definitions for messages and information elements. Similar text than the chapter 5 of this contribution.][

Message transfer syntax

[Editor's note:

The transfer syntax to be used is FFS.]

Timers

Handling of Unknown, Unforeseen and Erroneous Protocol Data

3Annex A (normative):

4History

Document history		
1.1.1	June 1999	<p><u>This revision contains updates due to decisions regarding the following contributions at RAN WG3 #4 in Warwick:</u></p> <ul style="list-style-type: none"> • R3-(99)490 (RL Load Indication procedure in chapter 8.2). • R3-(99)516 (Load Information, Load Information Request, Measurement reporting, and DL Power Control procedures in chapters 8.2 and 8.4. A new module is added to the RNSAP modules in chapter 5.1.). • R3-(99)493 (Physical Channel Reconfiguration in chapter 8.2 and the corresponding messages in chapter 9.1). • R3-(99)452 (RL SETUP, RL ADDITION, RL RECONFIGURATION PREPARE, and RL RECONFIGURATION messages in chapter 9.1). • R3-(99)583 (Uplink Signalling Transfer, Downlink Signalling Transfer, Common Transport Channel initialisation in chapter 8.2 and 8.4 and the corresponding messages in chapter 9.1). The chapter “Downlink Signalling Transfer” was moved back to chapter 8.3 (Common Transport Channel Procedures). • R3-(99)449 ([no] Parallel Transactions in chapter 5 and addition of Transaction Id as mandatory in all messages).
1.1.0	June 1999	<p><u>Approved by RAN WG3 with the following corrections:</u></p> <ul style="list-style-type: none"> • The specification number is corrected. • The chapter “Downlink Signalling Transfer” was moved from the chapter 8.1 (Basic Mobility Procedures) to chapter 8.3 (Common Transport Channel Procedures)
1.0.2	May 1999	<ul style="list-style-type: none"> • Chapters 8.1, 8.3, 9.1, and 9.2 are updated in accordance with the decisions made regarding R3-(99)341. • Chapters 9.1.22 and 9.2 are updated in accordance with the decision made regarding R3-(99)360. • A note is added to chapter 4 to reflect the decision on the “Source Signalling Address” made regarding R3-(99)360. • Abbreviations added in chapter 3.

1.0.1	April 1999	<ul style="list-style-type: none"> • Specification number changed to UMTS 25.413. • Title corrected UTRAN Iur Interface RNSAP Signalling. • A short scope is added. • Editors note added in chapter 5.1 “RNSAP Procedure Modules” to reflect the previous decision, as described in UMTS 25.420. • Chapter 8 updated in accordance with R3-(99)262. (RNS changed to RNC in a lot of places (primarily in relation to transmission or reception of messages) and SRNC Relocation is renamed to SRNS Relocation.) • The reference to YY.02 in the chapter “SRNS Relocation Commit” has been updated to refer to UMTS 25.931. • Chapter 9.2.45 “Transport Address” has been updated with a reference to 25.426 in accordance with R3-(99)275. • Chapter 12 has been deleted to avoid inconsistencies. • Chapter 7 is updated with a list of “elementary” procedures from chapter 8. • The title of chapter 8 is changed to “RNSAP Procedures” since not all procedures are true elementary procedures. • Chapter 8.2.11 “Uplink Outer Loop Power Control” has been removed in accordance with the decision to use inband signalling for this procedure was taken based on the Iur/1 Study Item Report R3-(99)282 • The list of messages in Chapter 9.1 (before 9.1.1) as well as the chapters 9.1.x are updated so that all messages described in chapter 8 are described. The messages not described in chapter 8 are deleted. This update also applied to the parameter “Message Type” in chapter 9.2.24. • All descriptions of messages in chapters 9.1.x have been removed. For a description of when the messages are used see chapter 8. • Chapter 9.2 is updated in accordance with R3-(99)348.
1.0.0	April 1999	Raised to version 1.0.0 by the TSG RAN meeting #3 in Japan, April 1999. The content is identical to version 0.1.0.
0.1.0	April 1999	Only version number stepped, otherwise same as 0.0.5.
0.0.5	April 1999	<ul style="list-style-type: none"> • Editor’s notes in ch. 9.1 and 9.2 modified to reflect agreements at WG3#2 in Nynäshamn, Sweden.
0.0.4	April 1999	<ul style="list-style-type: none"> • Elementary procedures in ch. 8 grouped into basic mobility-, DCH- and CCH procedures. • References added to msg. table in ch 9.1. • IEs in ch. 9.2 alphabetically ordered. • Started to add references in msg. contents tables in ch. 9.1.x. • Editor’s note in ch. 8.1.2 referring to study item Iu/3 removed since study item resolved. • Procedure Outer Loop Power Control renamed Up Link Outer Loop Power Control.
0.0.3	March 1999	<p>Updated according to changes at WG3#2 in Nynäshamn:</p> <ul style="list-style-type: none"> • Ch. 8.8 Cell/URA Update Indication procedure updated. • Ch. 8.16 CCHT Release Request procedure added. • Updated according to tdoc R3-99178, R3-99179, R3-99171, R3-99182, R3-99175, R3-99198.
0.0.2	February 1999	Introduction of content from the Merged Description of I _{ur} Interface, V0.0.2 1999-02.
0.0.1	February 1999	Document Structure Proposal.

Rapporteur for 3GPP UMTS 25.423is:

Göran Rune

Ericsson Radio Systems AB

Tel.: +46 13 287300

Fax : +46 13 277373

Email : goran.rune@era.ericsson.se

This document is written in Microsoft Word version 6.0/96.