

3G TS 25.142 V0.0.1 (1999-06)

Technical Specification

**3rd Generation Partnership Project;
Technical Specification Group Radio Access Network;
Working Group 4;
Base station conformance testing (TDD)**



Reference

DTS/TSG<name abbrev>-0<WG no><spec no> U

Keywords

<keyword[, keyword]>

3GPP

Postal address

3GPP support office address

650 Route des Lucioles - Sophia Antipolis
Valbonne - FRANCE
Tel.: +33 4 92 94 42 00 Fax: +33 4 93 65 47 16

Internet

<http://www.3gpp.org>

Contents

Intellectual Property Rights	7
Foreword	7
1 Scope.....	8
2 References	8
3 Definitions, symbols, and abbreviations.....	9
3.1 Definitions	9
3.2 Symbols	9
3.3 Abbreviations.....	9
4 Frequency bands and channel arrangement.....	10
4.1 General.....	10
4.2 Frequency bands	10
4.3 TX–RX frequency separation	10
4.4 Channel arrangement	10
4.4.1 Channel spacing	10
4.4.2 Channel raster.....	10
4.4.3 Channel number	10
5 General test conditions and declarations	11
5.1 Base station classes.....	11
5.2 Output power and determination of power class.....	11
5.3 Specified frequency range.....	11
5.4 Test environments.....	11
5.4.1 Normal test environment	11
5.4.2 Extreme test environment.....	12
5.4.2.1 Extreme temperature.....	12
5.4.3 Vibration	13
5.4.4 Power supply.....	13
5.4.5 Acceptable uncertainty of measurement equipment.....	13
5.5 Interpretation of measurement results	17
5.6 Selection of configurations for testing	17
5.7 BTS Configurations	17
5.7.1 Receiver diversity.....	18
5.7.2 Duplexers	18
5.7.3 Power supply options	18
5.7.4 Ancillary RF amplifiers.....	18
5.7.5 BSS using antenna arrays	19
5.8 Overview of the conformance test requirements.....	20
5.9 Format and interpretation of tests	21
6 Transmitter characteristics.....	22
6.1 General.....	22
6.2 Base station maximum output power	22
6.2.1 Test purpose	22
6.2.2 Test case.....	22
6.2.3 Essential conformance.....	23
6.3 Base station output power	23
6.3.1 Test purpose	23
6.3.2 Test case.....	23
6.3.3 Essential conformance.....	23
6.4 Frequency stability.....	24
6.4.1 Test purpose	24
6.4.2 Test case.....	24
6.4.3 Essential conformance.....	24

6.5	Output power dynamics	24
6.5.1	Closed loop power control	24
6.5.2	Power control steps	24
6.5.2.1	Test purpose	24
6.5.2.2	Test case	24
6.5.2.3	Essential conformance	24
6.5.3	Power control dynamic range	24
6.5.3.1	Test purpose	24
6.5.3.2	Test case	25
6.5.3.3	Essential conformance	25
6.5.4	Minimum transmit power	25
6.5.4.1	Test purpose	25
6.5.4.2	Test case	25
6.5.4.3	Essential conformance	25
6.5.5	Total power dynamic range	25
6.5.5.1	Test purpose	25
6.5.5.2	Test case	25
6.5.5.3	Essential conformance	25
6.5.6	Power control cycles per second	25
6.5.6.1	Test purpose	25
6.5.6.2	Test case	25
6.5.6.3	Essential conformance	25
6.5.7	Perch channel power	25
6.5.7.1	Test purpose	26
6.5.7.2	Test case	26
6.5.7.3	Essential conformance	26
6.6	Transmit ON/OFF ratio	26
6.6.1	Test purpose	26
6.6.2	Test case	26
6.6.3	Essential conformance	27
6.7	Output RF spectrum emissions	27
6.7.1	Occupied bandwidth	27
6.7.1.1	Test purpose	27
6.7.1.2	Test case	27
6.7.1.3	Essential conformance	27
6.7.2	Out of band emission	27
6.7.2.1	Spectrum emission mask	27
6.7.2.1.1	Test purpose	28
6.7.2.1.2	Test case	28
6.7.2.1.3	Essential conformance	28
6.7.2.2	Adjacent Channel Leakage power Ratio (ACLR)	28
6.7.2.2.1	Test purpose	28
6.7.2.2.2	Test case	28
6.7.2.2.3	Essential conformance	28
6.7.3	Spurious emissions	29
6.7.3.1	Test purpose	29
6.7.3.2	Test case	29
6.7.3.3	Essential conformance	29
6.8	Transmit intermodulation	30
6.8.1	Test purpose	30
6.8.2	Test case	30
6.8.3	Essential conformance	31
6.9	Modulation Accuracy	31
6.9.1	Test purpose	32
6.9.2	Test case	32
6.9.3	Essential conformance	32
7	Receiver characteristics	33
7.1	General	33

7.2	Reference sensitivity level	33
7.2.1	BS reference sensitivity level	33
7.2.1.1	Test purpose	33
7.2.1.2	Test case	33
7.2.1.3	Essential conformance	33
7.2.2	Maximum frequency deviation for receiver performance	33
7.2.2.1	Test purpose	33
7.2.2.2	Test case	33
7.2.2.3	Essential conformance	33
7.3	Dynamic range	33
7.3.1	Test purpose	34
7.3.2	Test case	34
7.3.3	Essential conformance	34
7.4	Adjacent Channel Selectivity (ACS)	34
7.4.1	Test purpose	34
7.4.2	Test case	34
7.4.3	Essential conformance	34
7.5	Blocking characteristics	34
7.5.1	Test purpose	34
7.5.2	Test case	34
7.5.3	Essential conformance	34
7.6	Spurious response	34
7.6.1	Test purpose	34
7.6.2	Test case	34
7.6.3	Essential conformance	35
7.7	Intermodulation characteristics	36
7.7.1	Test purpose	36
7.7.2	Test case	36
7.7.3	Essential conformance	37
7.8	Spurious emissions	37
7.8.1	Test purpose	37
7.8.2	Test case	37
7.8.3	Essential conformance	37
8	Performance requirements	38
8.1	General	38
8.2	Dynamic reference sensitivity performance	38
8.2.1	Performance in AWGN channel	38
8.2.1.1	Single link performance	38
8.2.1.1.1	Test purpose	38
8.2.1.1.2	Test case	38
8.2.1.1.3	Essential conformance	38
8.2.1.2	Multi link performance	38
8.2.1.2.1	Test purpose	38
8.2.1.2.2	Test case	38
8.2.1.2.3	Essential conformance	38
8.2.2	Performance in multipath fading channels	38
8.2.2.1	Single link performance	39
8.2.2.1.1	Performance without TPC	39
8.2.2.1.1.1	Test purpose	39
8.2.2.1.1.2	Test case	39
8.2.2.1.1.3	Essential conformance	39
8.2.2.1.2	Performance with TPC	39
8.2.2.1.2.1	Test purpose	39
8.2.2.1.2.2	Test case	39
8.2.2.1.2.3	Essential conformance	39
8.2.2.2	Multi link performance	39
8.2.2.2.1	Test purpose	39
8.2.2.2.2	Test case	39

8.2.2.2.3 Essential conformance 39
History..... 40

Intellectual Property Rights

IPRs essential or potentially essential to the present deliverable may have been declared to 3GPP and/or its organizational partners. The information pertaining to these essential IPRs, if any, is publicly available for **3GPP members and non-members, free of charge**. This can be found in the latest version of the 3GPP Technical Report:

Pursuant to the 3GPP Interim IPR Policy, no investigation, including IPR searches, has been carried out by 3GPP. No guarantee can be given as to the existence of other IPRs not referenced in the [tbd.], which are, or may be, or may become, essential to the present document.

Foreword

This Technical Specification has been produced by the 3GPP.

The contents of the present document are subject to continuing work within the TSG and may change following formal TSG approval. Should the TSG modify the contents of this TS, it will be re-released by the TSG with an identifying change of release date and an increase in version number as follows:

Version x.y.z

where:

- x the first digit:
 - 1 presented to TSG for information;
 - 2 presented to TSG for approval;
 - 3 Indicates TSG approved document under change control.
- y the second digit is incremented for all changes of substance, i.e. technical enhancements, corrections, updates, etc.
- z the third digit is incremented when editorial only changes have been incorporated in the specification;

d1 Scope

The present document specifies the Radio Frequency (RF) test methods and conformance requirements for UTRA Base Transceiver Stations (BTS) operating in the TDD mode. These have been derived from, and are consistent with, the core UTRA specifications specified in the requirements reference subclause of each test.

For each test, two conformance requirements are specified:

- essential conformance requirements;
- complete conformance requirements.

In the context of the present specification, essential conformance requirements are those which are required for an efficient use of the spectrum, so as to avoid undue interference and corresponding service degradation. In detail, essential requirements are required

- a) to ensure compatibility between the radio channels in the same cell;
- b) to ensure compatibility between cells, both co-ordinated and uncoordinated;
- c) to ensure compatibility with existing systems in the same or adjacent frequency bands.

System performance tests are not considered to include essential conformance requirements.

Essential conformance requirements are sufficient to verify the performance of the equipment for radio type approval purposes, in countries where this is applicable.

Complete conformance requirements may be tested to verify all aspects of the performance of a BTS. These requirements are intended to be used by manufacturers and operators to allow conformance and acceptance testing to be performed in a consistent manner; the tests to be performed should be agreed between the parties.

The present release of this specification defines the tests for essential conformance requirements only; tests for complete conformance requirements are due for later releases.

In this TS, the reference point for RF connections (except for the measurement of mean transmitted RF carrier power) is the antenna connector, as defined by the manufacturer. This TS does not apply to repeaters or RF devices which may be connected to an antenna connector of a BTS.

2 References

The following documents contain provisions which, through reference in this text, constitute provisions of the present document.

- References are either specific (identified by date of publication, edition number, version number, etc.) or non-specific.
- For a specific reference, subsequent revisions do not apply.
- For a non-specific reference, the latest version applies.
- A non-specific reference to an ETS shall also be taken to refer to later versions published as an EN with the same number.

- [1] TS 25.105: "BTS Radio Transmission and reception (TDD)".
- [2] ETR 027: "Methods of measurement for mobile radio equipment".
- [3] IEC 721: "Classification of environmental conditions"

- [4] IEC 68-2: "Basic environmental testing procedures; Part 2: Tests"
- [5] ETR 028: "Uncertainties in the measurement of mobile radio equipment characteristics"
-

3 Definitions, symbols, and abbreviations

3.1 Definitions

For the purposes of the present document, the [following] terms and definitions [given in ... and the following] apply.

<defined term>: <definition>.

example: text used to clarify abstract rules by applying them literally.

3.2 Symbols

For the purposes of the present document, the following symbols apply:

<symbol> <Explanation>

3.3 Abbreviations

For the purposes of the present document, the following abbreviations apply:

<ACRONYM> <Explanation>

4 Frequency bands and channel arrangement

4.1 General

The information presented in this section is based on a chip rate of 4.096 Mcps.

Note: Other chip rates may be considered in future releases.

4.2 Frequency bands

UTRA/TDD is designed to operate in the following bands:

1900 – 1920 MHz: Uplink and downlink transmission

2010 – 2025 MHz Uplink and downlink transmission

Deployment of TDD in the 1920-1980 MHz band is an open item.

Deployment in other frequency bands is not precluded.

4.3 TX–RX frequency separation

No TX-RX frequency separation is required as Time Division Duplex (TDD) is employed. Each TDMA frame consists of 16 timeslots where each timeslot can be allocated to either transmit or receive.

4.4 Channel arrangement

4.4.1 Channel spacing

The nominal channel spacing is 5 MHz, but this can be adjusted to optimize performance in a particular deployment scenario.

4.4.2 Channel raster

The channel raster is 200 kHz, which means that the carrier frequency must be a multiple of 200 kHz.

4.4.3 Channel number

The carrier frequency is designated by the UTRA absolute radio frequency channel number (UARFCN).

5 General test conditions and declarations

The requirements of this clause apply to all tests in this TS, when applicable.

The general conditions during the tests should be according to the relevant parts of ETR 027 [2] (methods of measurement for mobile radio equipment) with the exceptions and additions defined in the individual tests.

Many of the tests in this TS measure a parameter relative to a value which is not fully specified in the UTRA specifications. For these tests, the conformance requirement is determined relative to a nominal value specified by the manufacturer.

Certain functions of a BTS are optional in the UTRA specifications.

When specified in a test, the manufacturer shall declare the nominal value of a parameter, or whether an option is supported.

5.1 Base station classes

The requirements in this specification apply to base stations intended for general-purpose applications.

In future, further classes of base stations may be defined; the requirements for these may be different than for general-purpose applications.

5.2 Output power and determination of power class

The manufacturer shall declare the maximum output power of the base station which is defined as the mean power level per carrier at the antenna connector; see subclause 6.2.

5.3 Specified frequency range

The manufacturer shall declare:

- which of the frequency bands defined in sub-clause 4.2 is supported by the BSS.
- the frequency range within the above frequency band(s) supported by the BSS. As TDD is employed, the same frequency range is used for transmit and receive operation.

Many tests in this TS are performed with appropriate frequencies in the bottom, middle and top of the operating frequency band of the BTS. These are denoted as RF channels B (bottom), M (middle) and T (top).

When a test is performed by a test laboratory, the UARFCNs to be used for RF channels B, M and T shall be specified by the laboratory. The laboratory may consult with operators, the manufacturer or other bodies.

When a test is performed by a manufacturer, the UARFCNs to be used for RF channels B, M and T may be specified by an operator.

5.4 Test environments

For each test in this TS, the environmental conditions under which the BSS is to be tested are defined.

5.4.1 Normal test environment

When a normal test environment is specified for a test, the test should be performed under any combination of conditions between the minimum and maximum limits stated in table 5.4.1.1.

Table 5.4.1.1: Limits of conditions for Normal Test Environment

Condition	Minimum	Maximum
Barometric pressure	86 kPa	106 kPa
Temperature	15°C	30°C
Relative Humidity	20 %	85 %
Power supply	Nominal, as declared by the manufacturer	
Vibration	Negligible	

The ranges of barometric pressure, temperature and humidity represent the maximum variation expected in the uncontrolled environment of a test laboratory. If it is not possible to maintain these parameters within the specified limits, the actual values shall be recorded in the test report.

NOTE: This may, for instance, be the case for measurements of radiated emissions performed on an open field test site.

5.4.2 Extreme test environment

The manufacturer shall declare one of the following :

- The equipment class for the equipment under test, as defined in ETS 300 019-1-3 , (Equipment Engineering (EE); Environmental conditions and environmental test for telecommunications equipment, Part 1-3: Classification of environmental conditions, Stationary use at weather protected locations).
- The equipment class for the equipment under test, as defined in ETS 300 019-1-4 , (Equipment Engineering (EE); Environmental conditions and environmental test for telecommunications equipment, Part 1-4: Classification of environmental conditions, Stationary use at non-weather protected locations).
- For equipment that does not comply to an ETS 300 019-1 [11] class, the relevant classes from IEC 721 [3] documentation for Temperature, Humidity and Vibration shall be declared.

NOTE: Reduced functionality for conditions that fall out side of the standard operational conditions are not tested in this TS. These may be stated and tested separately.

5.4.2.1 Extreme temperature

When an extreme temperature test environment is specified for a test, the test shall be performed at the standard minimum and maximum operating temperatures defined by the manufacturer's declaration for the equipment under test.

Minimum temperature:

The test shall be performed with the environmental test equipment and methods of inducing the required environmental phenomena into the equipment, conforming to the test procedure of IEC 68-2-1 [4] , Environmental Testing, Part 2: Tests - Tests A: Cold. The equipment shall be maintained at the stabilized condition for the duration of the test sequence.

Maximum temperature:

The test shall be performed with the environmental test equipment and methods of inducing the required environmental phenomena in to the equipment, conforming to the test procedure of IEC 68-2-2 [4] (Environmental Testing, Part 2: Tests - Tests Bd Dry heat). The equipment shall be maintained at the stabilized condition for the duration of the test sequence.

NOTE: It is recommended that the equipment is made fully operational prior to the equipment being taken to its lower operating temperature.

5.4.3 Vibration

When vibration conditions are specified for a test, the test shall be performed while the equipment is subjected to a vibration sequence as defined by the manufacturers declaration for the equipment under test. This shall use the environmental test equipment and methods of inducing the required environmental phenomena in to the equipment, conforming to the test procedure of IEC 68-2-6 [4], Environmental Testing, Part 2: Tests - Test Fc and guidance: Vibration (Sinusoidal). Other environmental conditions shall be within the ranges specified in subclause 5.4.1, Normal test environment.

NOTE: The higher levels of vibration may induce undue physical stress in to equipment after a prolonged series of tests. The testing body should only vibrate the equipment during the RF measurement process.

5.4.4 Power supply

When extreme power supply conditions are specified for a test, the test shall be performed at the standard upper and lower limits of operating voltage defined by the manufacturer's declaration for the equipment under test.

Upper voltage limit

The equipment shall be supplied with a voltage equal to the upper limit declared by the manufacturer (as measured at the input terminals to the equipment). The tests shall be carried out at a steady state minimum and maximum limit declared by the manufacturer for the equipment, to the methods described in IEC 68-2-1 [4] Test Ab/Ad: Cold and IEC 68-2-2 Test Bb/Bd: Dry Heat.

Lower voltage limit

The equipment shall be supplied with a voltage equal to the lower limit declared by the manufacturer (as measured at the input terminals to the equipment). The tests shall be carried out at a steady state minimum and maximum limit declared by the manufacturer for the equipment, to the methods described in IEC 68-2-1 [4] Test Ab/Ad: Cold and IEC 68-2-2 [4] Test Bb/Bd: Dry Heat.

5.4.5 Acceptable uncertainty of measurement equipment

The maximum acceptable uncertainty of measurement equipment is specified separately for each test, where appropriate. The measurement equipment shall enable the stimulus signals in the test case to be adjusted to within the specified tolerance, and the conformance requirement to be measured with an uncertainty not exceeding the specified values. All tolerances and uncertainties are absolute values, unless otherwise stated.

Subclause 5.4, Test environments:

Pressure	± 5 kPa
Temperature	± 2 degrees
Relative Humidity	± 5 %
DC Voltage	$\pm 1,0$ %
AC Voltage	$\pm 1,5$ %
Vibration	10 %
Vibration frequency	0,1 Hz

The above values shall apply unless the test environment is controlled and the specification for the control of the test environment specifies the uncertainty for the parameter.

Transmitter

Subclause 6.2, Base station maximum output power:

Conformance requirement:

RF power, for static power step 0 $\pm 1,0$ dB

Subclause 6.3, Base station output power:

Conformance requirement:

RF power $\pm 1,0$ dB

Subclause 6.4, Frequency stability:

Conformance requirement:

Frequency ± 10 Hz

Subclause 6.5, Output power dynamics

Conformance requirement:

RF power, for static power steps (minimum and maximum Tx power) $\pm 1,0$ dB

Relative RF Power $\pm 0,7$ dB

Subclause 6.6, Transmit ON/OFF ratio:

Conformance requirement:

RF power difference

Power difference < 50 dB $\pm 0,7$ dB

Power difference ≥ 50 dB $\pm 1,5$ dB

Subclause 6.7, Output RF spectrum emissions

Conformance requirement:

RF power difference

Power difference < 50 dB $\pm 0,7$ dB

Power difference ≥ 50 dB $\pm 1,5$ dB

Relative RF power:

Offset from carrier, MHz	Power difference, dB	Uncertainty of relative power, dB

Spurious emissions

RF power

- inside the BTS transmit band ± 1.5 dB

- outside the BTS transmit band:

$f \leq 2$ GHz ± 1.5 dB

2 GHz $< f \leq 4$ GHz ± 2.0 dB

$f > 4$ GHz ± 4.0 dB

Subclause 6.8, Transmit intermodulation:

Test case:

Relative RF power (of injected signal); ± 1.5 dB

Conformance requirement (outside RX band):

RF power; absolute limit values ± 1.5 dB

RF power, relative measurements ± 2.0 dB

Conformance requirement (inside RX band):

RF power; absolute limit values $+4$ dB -3 dB

NOTE: The positive limit for uncertainty is greater than the negative limit because the measurement result can be increased (but not decreased) due to intermodulation products within the measurement apparatus.

Receiver

Where a measurement uncertainty of $+5$ dB -0 dB is specified for an input signal, the measured value of the input signal should be increased by an amount equal to the uncertainty with which it can be measured. This will ensure that the true value of the input signal is not below the specified nominal.

Subclause 7.2, Reference sensitivity level

Test case:

RF power ± 1.0 dB

Subclause 7.3, Dynamic range:

Test case:

RF power	± 1.5 dB
Relative RF power	± 3.0 dB

Subclause 7.4, Adjacent Channel Selectivity (ACS):

Test case:

RF power	± 1.5 dB
Relative RF power	± 3.0 dB

Subclause 7.5, Blocking characteristics:

Test case:

RF power, wanted signal	± 1.0 dB
RF power, interfering signal;	
$f \leq 2$ GHz	± 0.7 dB
2 GHz $< f \leq 4$ GHz	± 1.5 dB
$f > 4$ GHz	± 3.0 dB

Subclause 7.6, Spurious response:

Test case:

RF power, wanted signal	± 1.0 dB
RF power, interfering signal;	
$f \leq 2$ GHz	± 0.7 dB
2 GHz $< f \leq 4$ GHz	± 1.5 dB
$f > 4$ GHz	± 3.0 dB

Subclause 7.7, Intermodulation characteristics:

Test case:

RF power, wanted signal	± 1.0 dB
RF power, interfering signals	± 0.7 dB

Subclause 7.8, Spurious emissions:

Conformance requirement:

RF power;

$f \leq 2$ GHz	± 1.5 dB
2 GHz $< f \leq 4$ GHz	± 2.0 dB
$f > 4$ GHz	± 4.0 dB

5.5 Interpretation of measurement results

The measurement value related to the corresponding limit shall be used to decide whether an equipment meets a requirement in this TS.

The measurement uncertainty for the measurement of each parameter shall be included in the test report.

The recorded value for the measurement uncertainty shall be, for each measurement, equal to or lower than the appropriate figure in subclause 5.4 of this TS.

NOTE: This procedure is recommended in ETR 028 [5].

If the measurement apparatus for a test is known to have a measurement uncertainty greater than that specified in subclause 5.4, it is still permitted to use this apparatus provided that an adjustment is made to the measured value as follows:

The adjustment is made by subtracting the modulus of the specified measurement uncertainty in subclause 4.7 from the measurement uncertainty of the apparatus. The measured value is then increased or decreased by the result of the subtraction, whichever is most unfavourable in relation to the limit.

5.6 Selection of configurations for testing

Most tests in this TS are only performed for a subset of the possible combinations of test conditions. For instance:

- Not all TRXs in the configuration may be specified to be tested.
- Only one RF channel may be specified to be tested.
- Only one timeslot may be specified to be tested.

When a test is performed by a test laboratory, the choice of which combinations are to be tested shall be specified by the laboratory. The laboratory may consult with operators, the manufacturer or other bodies.

When a test is performed by a manufacturer, the choice of which combinations are to be tested may be specified by an operator.

5.7 BTS Configurations

This TS has been written to specify tests for the standard configurations of BTS which have been assumed in UTRA requirements specifications, in particular TS 25.105 "BTS Radio transmission and reception" [1]. However, there are other configurations of BTS which comply with these specifications, but for which the application of these specifications is not fully defined. For some such configurations there may be alternate ways to apply the requirements of this specification to testing of the configuration, or some variation in the test method may be necessary. It may therefore be necessary for the parties to the testing to reach agreement over the method of testing in advance.

If the BSS is supplied in a number of different environmental enclosures or configurations, it may not be necessary to test RF parameters for each environmental configuration, provided that it can be demonstrated that the equipment has been tested at the worst internal environmental conditions.

Where alternative interpretations of this specification are possible for a BSS configuration under test, the interpretation which has been adopted in performing the test shall be recorded with the test results.

Where variation in the test method within this TS has been necessary to enable a BSS configuration to be tested, the variation in the test method which has been made in performing the test shall be recorded with the test results. Where possible, agreement should be reached in advance about the nature of such a variation with any party who will later receive the test results.

Possible interpretations of this TS for some common configurations are given in the following subclauses.

5.7.1 Receiver diversity

- i) For the tests in clause 7 of this TS, the specified test signals may be applied to one receiver antenna connector, with the remaining receiver antenna connectors being terminated with 50 ohms.

or

- ii) For the tests in clause 7 of this TS, the specified test signals may be simultaneously applied to each of the receiver antenna connectors.

5.7.2 Duplexers

Due to TDD operation, there is no need to use a duplexer in the BSS.

5.7.3 Power supply options

If the BSS is supplied with a number of different power supply configurations, it may not be necessary to test RF parameters for each of the power supply options, provided that it can be demonstrated that the range of conditions over which the equipment is tested is at least as great as the range of conditions due to any of the power supply configurations.

This applies particularly if a BSS contains a DC rail which can be supplied either externally or from an internal mains power supply. In this case, the conditions of extreme power supply for the mains power supply options can be tested by testing only the external DC supply option. The range of DC input voltages for the test should be sufficient to verify the performance with any of the power supplies, over its range of operating conditions within the BTS, including variation of mains input voltage, temperature and output current.

5.7.4 Ancillary RF amplifiers

Ancillary RF amplifier: a piece of equipment, which when connected by RF coaxial cables to the BTS, has the primary function to provide amplification between the transmit and/or receive antenna connector of a BTS and an antenna without requiring any control signal to fulfil its amplifying function.

The requirements of this TS shall be met with the ancillary RF amplifier fitted. At tests according to clause 6 and 7 for TX and RX respectively, the ancillary amplifier is connected to the BTS by a connecting network (including any cable(s), attenuator(s), etc.) with applicable loss to make sure the appropriate operating conditions of the ancillary amplifier and the BTS. The applicable connecting network loss range is declared by the manufacturer. Other characteristics and the temperature dependence of the attenuation of the connecting network are neglected. The actual attenuation value of the connecting network is chosen for each test as one of the applicable extreme values. The lowest value is used unless otherwise stated.

Sufficient tests should be repeated with the ancillary amplifier fitted and, if it is optional, without the ancillary RF amplifier to verify that the BSS meets the requirements of this TS in both cases.

5.7.5 BSS using antenna arrays

A BSS may be configured with a multiple antenna port connection for some or all of its TRXs or with an antenna array related to one cell (not one array per TRX). This subclause applies to a BSS which meets at least one of the following conditions:

- The transmitter output signals from one or more TRX appear at more than one antenna port, or
- there is more than one receiver antenna port for a TRX or per cell and an input signal is required at more than one port for the correct operation of the receiver (NOTE: diversity reception does not meet this requirement) thus the outputs from the transmitters as well as the inputs to the receivers are directly connected to several antennas (known as "aircombining"), or
- transmitters and receivers are connected via duplexers to more than one antenna

If a BSS is used, in normal operation, in conjunction with an antenna system which contains filters or active elements which are necessary to meet the UTRA requirements, the tests of essential conformance may be performed on a system comprising the BSS together with these elements, supplied separately for the purposes of testing. In this case, it must be demonstrated that the performance of the configuration under test is representative of the system in normal operation, and the conformance assessment is only applicable when the BSS is used with the antenna system.

For testing of essential conformance of such a BSS, the following procedure may be used:

Receiver tests

For each test, the test signals applied to the receiver antenna connectors shall be such that the sum of the powers of the signals applied equals the power of the test signal(s) specified in the test.

An example of a suitable test configuration is shown in figure 5.7.5.1.

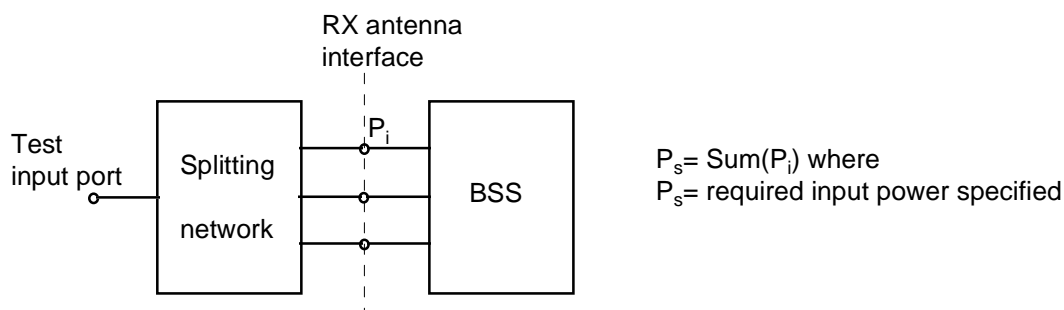

Figure 5.7.5.1: Receiver test setup

For spurious emissions from the receiver antenna connector, the test may be performed separately for each receiver antenna connector.

Transmitter tests

For each test, the conformance requirement shall be met by the sum of the signals emitted by each transmitter antenna connector. This may be assessed by separately measuring the signals emitted by each antenna connector and summing the results, or by combining the signals and performing a single measurement. The characteristics (e.g. amplitude and phase) of the combining network should be such that the power of the combined signal is maximised.

An example of a suitable test configuration is shown in figure 5.7.5.2.

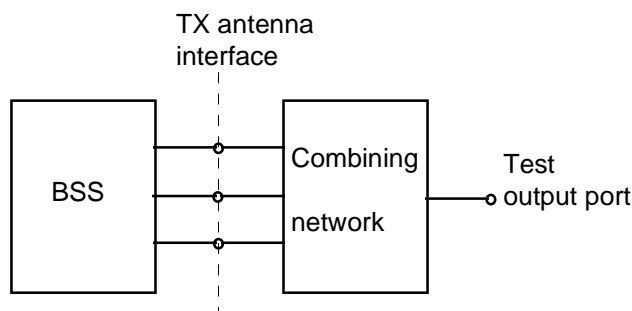

Figure 5.7.5.2: Transmitter test setup

For Intermodulation attenuation, the test may be performed separately for each transmitter antenna connector.

5.8 Overview of the conformance test requirements

Tables 5.8.2, 5.8.3 and 5.8.4 give an overview of the conformance test requirements for the transmitter, the receiver and system performance, respectively.

Table 5.8.2: Overview of the conformance tests requirements for the transmitter

Requirement specified in reference TS [1]		Sub-clause of Conformance Test TS	Essential conformance test required
Name	Sub-clause of [1]		
Base station maximum output power	6.2		yes
Base station output power	6.3		yes
Frequency stability	6.4		yes
Output power dynamics	6.5		-
Closed loop power control	6.5.1		-
Power control steps	6.5.2		no
Power control dynamic range	6.5.3		no
Minimum transmit power	6.5.4		no
Total power dynamic range	6.5.5		no
Power control cycles per second	6.5.6.		no
Perch channel power	6.5.7.		?
Transmit ON/OFF ratio	6.6		yes
Output RF spectrum emissions	6.7		-
Occupied bandwidth	6.7.1		yes
Out-of-band emission	6.7.2		-
Spectrum emission mask	6.7.2.1		yes
Adjacent Channel Leakage power Ratio (ACLR)	6.7.2.2		yes
Spurious emissions	6.7.3		yes
Transmit intermodulation	6.8		yes
Modulation accuracy	6.9		no

Table 5.8.3: Overview of the conformance tests requirements for the receiver

Requirement specified in reference TS [1]		Sub-clause of Conformance Test TS	Essential conformance test required
Name	Sub-clause of [1]		
Reference sensitivity level	7.2		-
BS reference sensitivity level	7.2.1		no
Maximum frequency deviation for receiver performance	7.2.2		no
Dynamic range	7.3		no
Adjacent Channel Selectivity (ACS)	7.4		yes
Blocking characteristics	7.5		yes
Spurious response	7.6		yes
Intermodulation characteristics	7.7		yes
Spurious emissions	7.8		yes

Table 5.8.4: Overview of the conformance test requirements for system performance

Requirement specified in reference TS [1]		Sub-clause of Conformance Test TS	Essential conformance test required
Name	Sub-clause of [1]		
Dynamic reference sensitivity performance	8.2		-
Performance in AWGN channel	8.2.1		-
Single link performance	8.2.1.1		no
Multi link performance	8.2.1.2		no
Performance in multipath fading channels	8.2.2		-
Single link performance	8.2.2.1		no
Performance without TPC	8.2.2.1.1		no
Performance with TPC	8.2.2.1.2		no
Multi link performance	8.2.2.2		no

5.9 Format and interpretation of tests

Each test in the following clauses has a standard format:

X Title

X.1 Test purpose

This subclause defines the purpose of the test.

X.2 Test case

This subclause describes the steps necessary to perform the test. The general test conditions described in clause 5 also apply.

X.3 Essential conformance

The essential conformance describes the conformance requirements necessary to ensure compatibility and to verify the important aspects of the transmission quality of the system. This subclause is divided into two parts:

Test environment

This subclause describes the test environment or environments under which the test shall be performed. Where more than one test environment is specified, the extent of testing is specified for each environment.

Conformance requirement

This subclause describes the requirement which shall be met for the specified tests.

The test case describes the testing for full conformance; for most tests a subset of these tests is specified for essential conformance. Therefore, any definition of testing in the essential conformance shall take precedence over the test case.

X.4 Complete conformance (in later releases only)

The complete conformance describes the complete set of tests which may be performed to fully characterize all aspects of one performance parameter of the BSS.

Test environment

This subclause describes the test environment or environments under which the test shall be performed. Where more than one test environment is specified, the extent of testing is specified for each environment.

Conformance requirement

This subclause describes the requirement which shall be met for the specified tests.

6 Transmitter characteristics

6.1 General

Unless otherwise stated, all measurements shall be made at the BTS antenna connector.

6.2 Base station maximum output power

6.2.1 Test purpose

The maximum output power, P_{max} , of the base station is the mean power level per carrier that the manufacturer has declared to be available at the antenna connector. The test purpose is to verify the accuracy of the maximum output power across the frequency range and under normal and extreme conditions.

6.2.2 Test case

< Editor's note: This section is tentatively based on text in TS 25.141 V0.1.0, which, in turn, is taken from Section 6.1.1.2 of ARIB Vol. 5. >

1. Connect the power measuring equipment to the base station RF output port.
2. Set the base station to transmit an appropriate signal (TBD).

< Editor's note: Further work needed to define the composition of the transmitted signal. >

3. Measure the mean power at the RF output port.

6.2.3 Essential conformance

Test Environment

Normal: Each TRX specified in the test case shall be tested.

Extreme power supply: One TRX shall be tested, on one ARFCN, for static power step zero only.

Conformance requirement

Static Power Level 0 corresponds to the maximum power declared by the manufacturer.

The power measured when the TRX is set to Static Power Level 0 shall have a tolerance of +TBD dB and –TBD dB under normal conditions and of +TBD dB and –TBD dB under extreme conditions, relative to the maximum power declared by the manufacturer. In this test, this measured power is termed the maximum BTS output power.

6.3 Base station output power

6.3.1 Test purpose

The output power, P_{out} , of the base station is the mean power of one carrier delivered to a load with resistance equal to the nominal load impedance of the transmitter during one slot. The test purpose is to verify the accuracy of the output power across the frequency range and under normal and extreme conditions.

6.3.2 Test case

< Editor's note: This section is tentatively based on text in TS 25.141 V0.1.0, which, in turn, is taken from Section 6.1.1.2 of ARIB Vol. 5. >

1. Connect the power measuring equipment to the base station RF output port.
2. Set the base station to transmit an appropriate signal (TBD).

< Editor's note: Further work needed to define the composition of the transmitted signal. >

3. Measure the mean power at the RF output port.

6.3.3 Essential conformance

Test Environment

Normal: Each TRX specified in the test case shall be tested.

Extreme power supply: One TRX shall be tested, on one ARFCN, for static power step zero only.

Conformance requirement

The power measured shall have a tolerance of +TBD dB and –TBD dB under normal conditions and of +TBD dB and –TBD dB under extreme conditions.

6.4 Frequency stability

6.4.1 Test purpose

Frequency stability is the ability of the BS to transmit at the assigned carrier frequency. The test purpose is to verify that the frequency stability is within the specified limits under normal and extreme test conditions.

6.4.2 Test case

Frequency stability shall be measured by sampling the transmitter RF output.

6.4.3 Essential conformance

Test Environment

Normal: One test shall be performed on each of B, M and T.

Extreme power supply: One test shall be performed on each of B, M and T.

NOTE: Tests under extreme power supply also test extreme temperature.

Conformance requirement

The frequency stability measured under normal and under extreme conditions shall be within \pm TBD ppm.

6.5 Output power dynamics

6.5.1 Closed loop power control

Closed loop power control is the ability of the BS transmitter to adjust its output power in response to the UL received signal.

For closed loop correction on the Downlink Channel (with respect to the open loop estimate), the base station adjust its mean output power level in response to each valid power control bit received from the UE on the Uplink Channel.

Output power dynamics tests are not considered to include essential conformance requirements. Therefore, in agreement with the scope of this edition as stated in clause 1, details for these tests will be given in later editions only.

6.5.2 Power control steps

6.5.2.1 Test purpose

The power control step is the minimum step change in the BS transmitter output power in response to a TPC message from the UE. The test purpose is to verify that the step size is within the specified limits.

6.5.2.2 Test case

6.5.2.3 Essential conformance

6.5.3 Power control dynamic range

6.5.3.1 Test purpose

The power control dynamic range is the difference between the maximum and the minimum transmit output power for a specified reference condition. The test purpose is to verify that the dynamic range is compliant with the specified value.

6.5.3.2 Test case

6.5.3.3 Essential conformance

6.5.4 Minimum transmit power

6.5.4.1 Test purpose

The BS transmits with its minimum controlled output power when the power control setting is set to a minimum value. This state occurs when the power control indicates that a minimum transmit output power is required.

6.5.4.2 Test case

6.5.4.3 Essential conformance

6.5.5 Total power dynamic range

The power control dynamic range is the difference between the maximum and the minimum transmit output power for a specified reference condition.

6.5.5.1 Test purpose

6.5.5.2 Test case

6.5.5.3 Essential conformance

6.5.6 Power control cycles per second

6.5.6.1 Test purpose

The test purpose is to verify the ability of the BS to follow power control commands at the specified rate (cycles per second).

or

The test purpose is to verify the ability of the BS to generate power control commands in the DL, with the aim to adjust the UE transmitted power.

6.5.6.2 Test case

6.5.6.3 Essential conformance

6.5.7 Perch channel power

< Editor's note: The name and the use of the common control channel may need to be adapted, subject to WG1 definition. >

- 6.5.7.1 Test purpose
- 6.5.7.2 Test case
- 6.5.7.3 Essential conformance

6.6 Transmit ON/OFF ratio

6.6.1 Test purpose

Transmit ON/OFF ratio is defined as the ratio of the maximum output transmit power within the channel bandwidth with the transmitter ON and OFF. The test purpose is to verify that the measured ON/OFF ratio is compliant with the specified value.

6.6.2 Test case

< Editor's note: This section is tentatively based on text in TS 25.141 V0.1.0, which, in turn, is taken from Section 6.1.1.7 of ARIB Vol. 5. Additional amendments as proposed in R4-99195 >

Refer to figure 6.6.2.1 for a functional block diagram of the test setup.

1. Connect the base station RF output port to the spectrum analyzer.

2. Set the spectrum analyzer condition as follows.

Median frequency	: carrier frequency
Sweep spectrum range	: 0 Hz
Resolution bandwidth	: Root raised cosine 4,096 MHz
Video bandwidth	: Video filtering not required
Y-axis scale	: 10dB/div
Input level	: 70% to 90% of full scale
Sweep mode	: zero span
Sweep trigger	: to be defined
Sweep time	: to be defined
Detection mode	: RMS power

3. Set the base station to transmit an appropriate signal (TBD). Total power at the RF output port shall be the nominal power as specified by the manufacturer.

< Editor's note: Further work needed to define the composition of the transmitted signal. >

4. Measure the transmission on power.

5. Stop the transmission of the base station.

6. Measure the transmission off power.

7. Calculate the on/off ratio

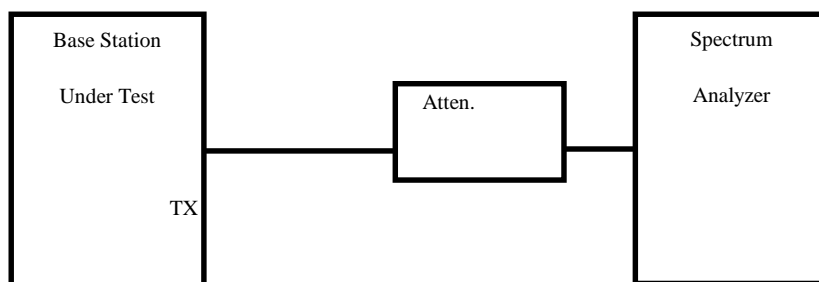

Figure 6.6.2.1: Functional setup for transmission on/off ratio test.

6.6.3 Essential conformance

6.7 Output RF spectrum emissions

6.7.1 Occupied bandwidth

6.7.1.1 Test purpose

Occupied bandwidth is a measure of the bandwidth containing 99% of the total integrated power for transmitted spectrum and is centered on the assigned channel frequency. The occupied channel bandwidth is less than 5 MHz based on a chip rate of 4.096 Mcps.

< Editor's note: Needs to be reviewed for the conformance specification. >

6.7.1.2 Test case

6.7.1.3 Essential conformance

6.7.2 Out of band emission

Out of band emissions are unwanted emissions immediately outside the [channel] bandwidth resulting from the modulation process and non-linearity in the transmitter but excluding spurious emissions. This out of band emission limit can be specified in terms of a spectrum emission mask or adjacent channel power ratio for the transmitter.

6.7.2.1 Spectrum emission mask

< Editor's note: The emission mask of the base station is an item for further study. >

- 6.7.2.1.1 Test purpose
- 6.7.2.1.2 Test case
- 6.7.2.1.3 Essential conformance

6.7.2.2 Adjacent Channel Leakage power Ratio (ACLR)

Adjacent Channel Leakage power Ratio (ACLR) is the ratio of the transmitted power from one carrier within a reference bandwidth of [4.096 MHz] to the power measured within a reference bandwidth of [4.096 MHz] centered on the adjacent(s) channel(s).

- 6.7.2.2.1 Test purpose
- 6.7.2.2.2 Test case

< Editor's note: This section is tentatively based on text in TS 25.141 V0.1.0, which, in turn, is taken from Section 6.1.1.3 of ARIB Vol. 5. Additional amendments as proposed in R4-99195 >

1. Connect a spectrum analyzer (or other suitable test equipment) to the base station RF output port, using an attenuator or directional coupler if necessary.
2. The spectrum analyzer (Digital storage type) is set as shown below.

Median frequency : carrier frequency and each of the adjacent channel frequencies

Sweep spectrum range : 0 Hz

Resolution bandwidth : root-raised cosine 4,096 MHz

Averaging : 1000 power averages (for 0,2 dB error at 95% confidence)

Input level : maximum amplitude is to be 70% to 90% of the full scale

Sweep mode : zero span

Sweep trigger : to be defined

Detection mode : peak of true power

3. Set the base station to transmit an appropriate signal. Total power at the RF output port shall be the nominal power as specified by the manufacturer.

< Editor's note: Further work needed to define the composition of the transmitted signal. >

4. Measure the power level at the carrier frequency and at each of the adjacent channel frequencies.

- 6.7.2.2.3 Essential conformance

Table 6.7.2.2.3.1: BS ACLR limits

BS channel	ACLR limit
± First adjacent channel	[] dBc
± Second adjacent channel	[] dBc

NOTE: In order to ensure that switching transients do not degrade the ACLR value the reference measurements conditions are an item for further study.

6.7.3 Spurious emissions

Spurious emissions are emissions which are caused by unwanted transmitter effects such as harmonics emission, parasitic emission, intermodulation products and frequency conversion products, but exclude out of band emissions. This is measured at the base station RF output port.

6.7.3.1 Test purpose

6.7.3.2 Test case

< Editor's note: This section is tentatively based on text in TS 25.141 V0.1.0, which, in turn, is taken from Section 6.1.1.4 of ARIB Vol. 5. >

1. Connect a spectrum analyzer to the base station RF output port, using an attenuator or directional coupler if necessary.
2. The spectrum analyzer (Digital storage type) is set as shown below.

Median frequency : spurious frequency

Sweep spectrum range : [**]Hz

Resolution bandwidth : [**]Hz

Video bandwidth : Equivalent of resolution bandwidth

Y-axis scale : 10dB/div

Input level : Maximum amplitude is to be 70% to 90% of the full scale

Sweep mode : Single mode

Sweep trigger : Freerun or video trigger. Generally + voltage, but adjustment is necessary.

Sweep time : [**]msec

Detection mode : Sample mode

3. Set the base station to transmit an appropriate signal. Total power at the RF Output port shall be the nominal power as specified by the manufacturer.

< Editor's note: Further work needed to define the composition of the transmitted signal. >

4. Measure the power level at the carrier frequency.

5. Sweep the spectrum analyzer over a frequency range from a low radio frequency (about 25 MHz) to three times the carrier frequency at least.

6.7.3.3 Essential conformance

< Editor's note: Further input required. >

6.8 Transmit intermodulation

The transmit intermodulation performance is a measure of the capability of the transmitter to inhibit the generation of signals in its non linear elements caused by presence of the wanted signal and an interfering signal reaching the transmitter via the antenna.

The transmit intermodulation shall be defined by the ratio of the output power of subject transmitted signal to the output power of intermodulation product when an interference signal (that differs from frequency of subject signal) is added at a level [**]dB lower than that of the subject signal. The frequency of the interference signal shall be [**]MHz or more off the subject signal, however, as for interference signal whose frequency is in the range of 5 MHz to 10 MHz off the subject signal, adjacent channel leakage power is used instead of the output of intermodulation product.

6.8.1 Test purpose

To verify that the RF transmit equipment is able to restrict the generation of signals in its non-linear elements caused by the presence of the RF output from the transmitter and an interfering signal reaching the transmitter via its antenna to below specified levels.

6.8.2 Test case

< Editor's note: This section is tentatively based on text in TS 25.141 V0.1.0, which, in turn, is taken from Section 6.1.1.4 of ARIB Vol. 5. >

1. Configure the base station according to the test model described in figure 6.8.2.1.
2. Conditions for measuring instrument is set as follows:
 - (1) The transmitting wave must have enough directivity so that no leak nor measurement error occurs in the standard signal generator.
 - (2) Setting of standard signal generator:

Median frequency: Transmission average frequency • [**]MHz
 - (3) The spectrum analyzer (Digital storage type) is set as shown below.

Median frequency : Intermodulation spurious frequency

Sweep spectrum range : [**]Hz

Resolution bandwidth : [**]Hz

Video bandwidth : Equivalent of resolution bandwidth

Y-axis scale : 10dB/div

Input level : Maximum amplitude is to be 70% to 90% of the full scale

Sweep mode : Single mode

Sweep trigger : Freerun or video trigger. Generally + voltage, but adjustment is necessary.

Sweep time : [**]msec

Detection mode : Sample mode
3. Set the base station to transmit an appropriate signal.

< Editor's note: Further work needed to define the composition of the transmitted signal. >

4. Set the median Frequency of the standard signal generator at the carrier +[**]MHz (or -[**]MHz) and set the output level of standard signal generator so that a maximum transmission output of -[**]dB is in terms of the unit under test antenna output end calculation.
5. Set the switching selector on the unit under test side and obtain power of transmission intermodulated wave by the spectrum analyzer.
6. The ratio of the maximum transmission output and the maximum value of power obtained in 2 corresponds to the transmission intermodulation.

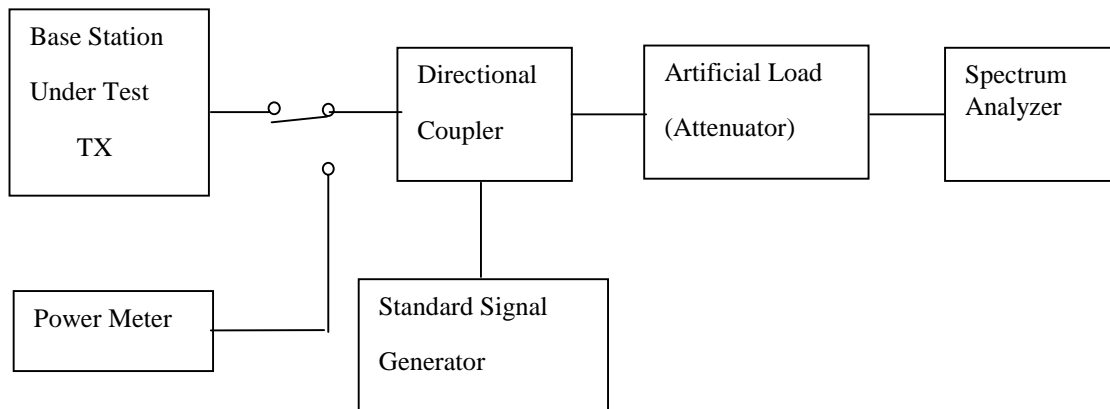

Figure 6.8.2.1: Functional setup for Base Station intermodulation spurious response tests

6.8.3 Essential conformance

The Transmit intermodulation level against the mean output power per carrier of the base station shall not exceed the limits specified below.

[If the mean transmission power is no more than 25W : 25 μ W(-16dBm) / 1MHz or less.]

[If the mean transmission power is more than 25W : -60dBc/1MHz or less, and 20mW (+13dBm) / 1MHz or less.]

< Editor's note: This is based on an ARIB input. Further input for co-located cellular systems is needed. >

6.9 Modulation Accuracy

The modulation accuracy is a measure of the difference between the measured waveform and the theoretical modulated waveform (the error vector). It is the square root of the ratio of the mean error vector power to the mean reference signal power expressed as %. The measurement interval is one timeslot.

Modulation accuracy tests are not considered to include essential conformance requirements. Therefore, in agreement with the scope of this edition as stated in clause 1, details for these tests will be given in later editions only.

- 6.9.1 Test purpose
- 6.9.2 Test case
- 6.9.3 Essential conformance

7 Receiver characteristics

7.1 General

All tests unless otherwise stated in this subclause shall be conducted on Base Station Systems fitted with a full complement of Transceivers for the configuration. The manufacturer shall provide appropriate logical or physical test access to perform all tests in this subclause. Measurements shall include any RX multicoupler.

The tests in this subclause assume that the receiver is not equipped with diversity. For receivers with diversity, the tests may be performed by applying the specified signals to one of the receiver inputs, and terminating or disabling the other(s). The tests and requirements are otherwise unchanged.

For receivers with diversity, testing of essential conformance shall be performed by applying the specified signals to one of the receiver inputs, and terminating or disabling the other(s).

In all the relevant subclauses in this clause all Bit Error Ratio (BER), Residual BER (RBER) and Frame Erasure Ratio (FER) measurements shall be carried out according to the general rules for statistical testing.

Unless detailed the receiver characteristic are specified at each antenna connector of the BS.

7.2 Reference sensitivity level

The reference sensitivity is the minimum receiver input power measured at the antenna connector at which the FER/BER does not exceed the specific value indicated in section 7.3.1. The signal power is equally applied to each antenna connector for diversity.

Reference sensitivity level tests are not considered to include essential conformance requirements. Therefore, in agreement with the scope of this edition as stated in clause 1, details for these tests will be given in later editions only.

7.2.1 BS reference sensitivity level

7.2.1.1 Test purpose

7.2.1.2 Test case

7.2.1.3 Essential conformance

7.2.2 Maximum frequency deviation for receiver performance

7.2.2.1 Test purpose

7.2.2.2 Test case

7.2.2.3 Essential conformance

7.3 Dynamic range

The receiver dynamic range is the input power range at each BS antenna connector over which the [FER/BER] does not exceed a specific rate.

Dynamic range tests are not considered to include essential conformance requirements. Therefore, in agreement with the scope of this edition as stated in clause 1, details for these tests will be given in later editions only.

7.3.1 Test purpose

7.3.2 Test case

7.3.3 Essential conformance

7.4 Adjacent Channel Selectivity (ACS)

7.4.1 Test purpose

Adjacent channel selectivity (ACS) is a measure of the receiver ability to receive a wanted signal at its assigned channel frequency in the presence of an adjacent channel signal at a given frequency offset from the center frequency of the assigned channel. ACS is the ratio of the receiver filter attenuation on the assigned channel frequency to the receiver filter attenuation on the adjacent channel(s).

7.4.2 Test case

7.4.3 Essential conformance

7.5 Blocking characteristics

7.5.1 Test purpose

The blocking characteristics is a measure of the receiver ability to receive a wanted signal at its assigned channel frequency in the presence of an unwanted interferer on frequencies other than those of the spurious response or the adjacent channels; without this unwanted input signal causing a degradation of the performance of the receiver beyond a specified limit. The blocking performance shall apply at all frequencies except those at which a spurious response occurs.

< Editor's note: The frequency range (in band/out of band) and level of the interfering signal is an item for further study. >

< Editor's note: The definition of the exemptions needs to be reconsidered, since it is unclear. >

7.5.2 Test case

7.5.3 Essential conformance

7.6 Spurious response

7.6.1 Test purpose

Spurious response is a measure of the receiver's ability to receive a wanted signal on its assigned channel frequency without exceeding a given degradation due to the presence of an unwanted CW interfering signal at any other frequency at which a response is obtained i.e. for which the blocking limit is not met.

7.6.2 Test case

< Editor's note: This section is tentatively based on text in TS 25.141 V0.1.0, which, in turn, is taken from Section 6.1.2.6 of ARIB Vol. 5. >

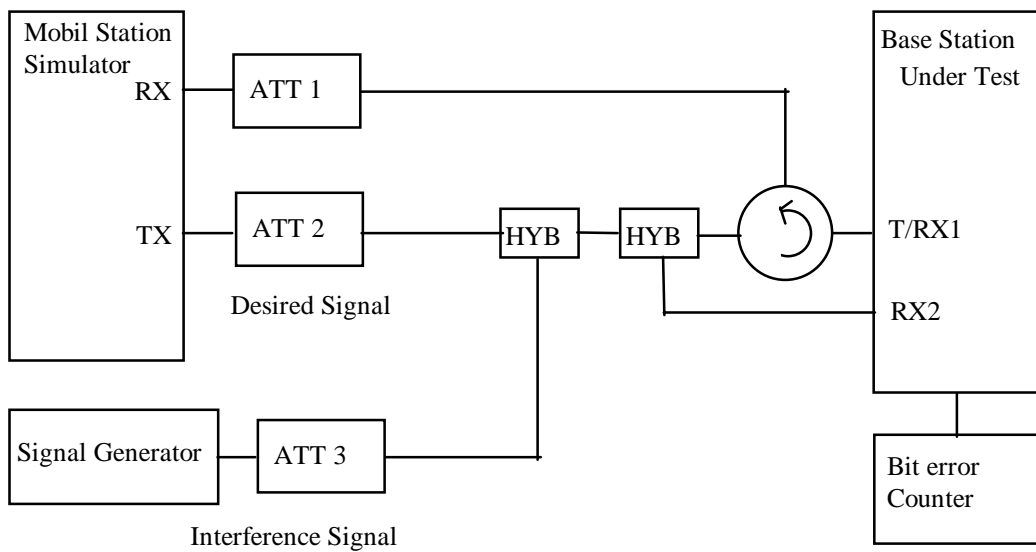
(a) Measuring system diagram**Figure 7.6.2.1: Measuring system setup for spurious response****(b) Measurement method**

1. Connect the BTS to a mobile station simulator and a Signal generator.
2. Transmitter power control (TPC) is disabled.*
3. Adjust the mobile station simulator to a level 3dB above the minimum required reference sensitivity level.
4. Adjust the Signal generator level to the level specified for the BTS type under test.
5. The signal generator shall now be swept over the specified frequency band with a defined increment.
6. Measure the performance (FER/BER) as appropriate.
7. The requirement shall be met for all information rates and services specified for the BTS.

*Necessity and method of closed loop measurement is for future study.

7.6.3 Essential conformance

The static reference performance as specified in clause 7.3.1 should be met for all data rates.

7.7 Intermodulation characteristics

7.7.1 Test purpose

Third and higher order mixing of the two interfering RF signals can produce an interfering signal in the band of the desired channel. Intermodulation response rejection is a measure of the capability of the receiver to receive a wanted signal on its assigned channel frequency in the presence of two or more interfering signals which have a specific frequency relationship to the wanted signal.

7.7.2 Test case

< Editor's note: This section is tentatively based on text in TS 25.141 V0.1.0, which, in turn, is taken from Section 6.1.2.5 of ARIB Vol. 5. >

(a) Measuring system diagram

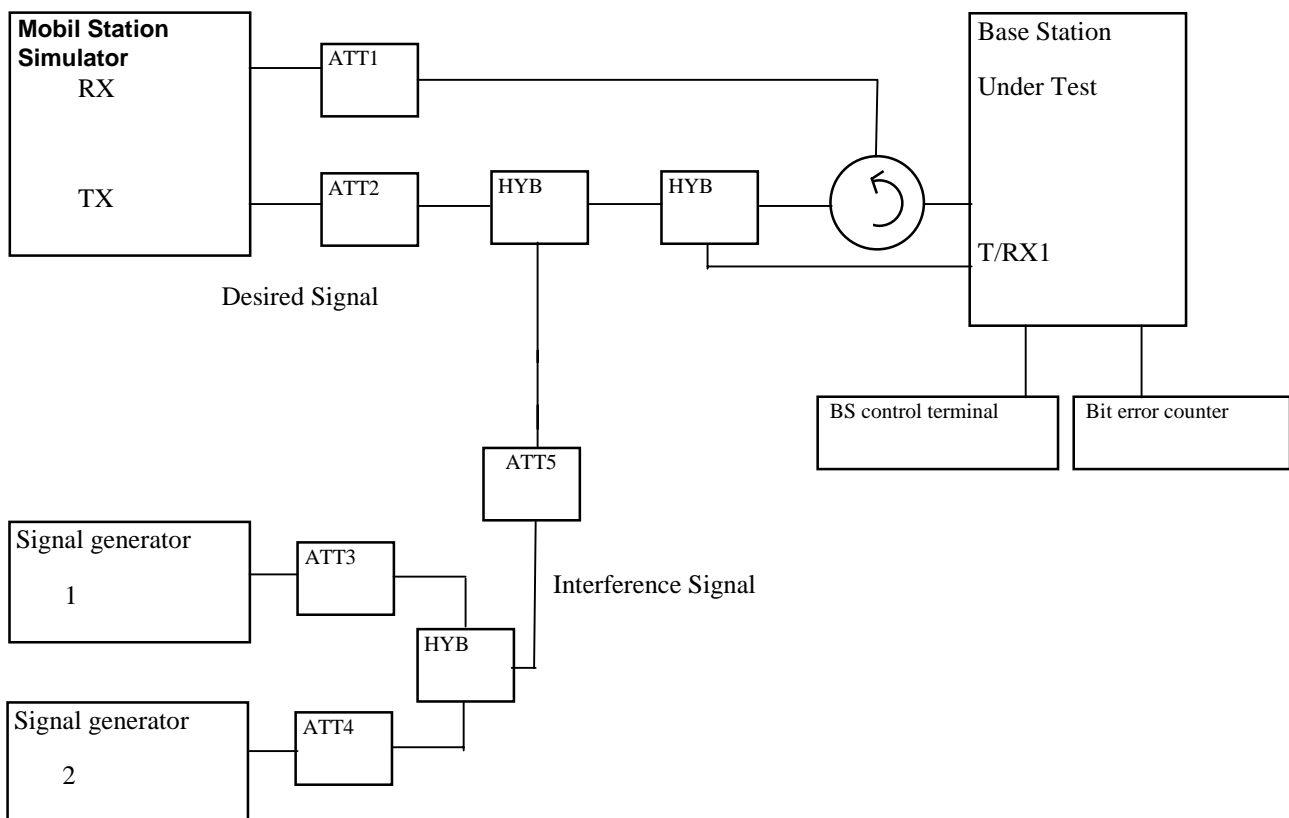

Figure 7.7.2.1: Measuring system setup for reception intermodulation sensitivity

(b) Measurement method

1. Connect the BTS to a mobile station simulator and a Signal generator.
2. Transmitter power control (TPC) is disabled.*

3. Transmit a PN signal from the MS simulator with a level 3dB higher than the minimum required sensitivity level. (refer to 6.1.2.2)
4. Adjust the Signal generators to frequency offsets of [+10**] MHz and [+20.1**] MHz from the assigned WCDMA channel.
5. Adjust the power of the Signal generators to the absolute value specified for the base station type.
6. Measure the performance (FER/BER) of the base station.
7. Repeat the measurement for frequency offsets [-10**] MHz and [-20.1**] MHz.

* Necessity and method of closed loop measurement is for future study.

** These values are working assumption for the 5MHz carrier spacing.

7.7.3 Essential conformance

The static reference performance as specified in clause 7.3.1 should be met for all data rates.

7.8 Spurious emissions

< Editor's note: Text to be added. >

7.8.1 Test purpose

7.8.2 Test case

7.8.3 Essential conformance

8 Performance requirements

8.1 General

Performance requirements are specified for a number of test environments and multi-path channel classes.

System performance tests are not considered to include essential conformance requirements. Therefore, in agreement with the scope of this edition as stated in clause 1, details for these tests will be given in later editions only.

8.2 Dynamic reference sensitivity performance

The minimum required dynamic reference sensitivity performance is specified according to the traffic rate and the propagation conditions.

8.2.1 Performance in AWGN channel

The performance requirement in AWGN channel is determined by the E_b/I_0 required for BER=10⁻³, 10⁻⁶. The BER is calculated for each of the possible data services.

8.2.1.1 Single link performance

8.2.1.1.1 Test purpose

8.2.1.1.2 Test case

8.2.1.1.3 Essential conformance

8.2.1.2 Multi link performance

8.2.1.2.1 Test purpose

8.2.1.2.2 Test case

8.2.1.2.3 Essential conformance

8.2.2 Performance in multipath fading channels

The performance requirement of reverse link with/without TPC in multipath fading channels is determined by the E_b/I_0 required for BER=10⁻³, 10⁻⁶. The BER is calculated for each of the possible data services.

- 8.2.2.1 Single link performance
 - 8.2.2.1.1 Performance without TPC
 - 8.2.2.1.1.1 Test purpose
 - 8.2.2.1.1.2 Test case
 - 8.2.2.1.1.3 Essential conformance
 - 8.2.2.1.2 Performance with TPC
 - 8.2.2.1.2.1 Test purpose
 - 8.2.2.1.2.2 Test case
 - 8.2.2.1.2.3 Essential conformance
- 8.2.2.2 Multi link performance
 - 8.2.2.2.1 Test purpose
 - 8.2.2.2.2 Test case
 - 8.2.2.2.3 Essential conformance

History

Document history		
V0.0.1	1999-06-14	First draft, based on text blocks taken from prI-ETS 300 609-1, 3GPP TS 25.141V0,1.0
Editor for 3G TS 24.142		