

TS 25.101 v2.0.0 (1999-06)

**3rd Generation Partnership Project (3GPP)
Technical Specification Group (TSG) RAN WG4
UE Radio transmission and Reception (FDD)**



The present document has been developed within the 3rd Generation Partnership Project (3GPP™) and may be further elaborated for the purposes of 3GPP. The present document has not been subject to any approval process by the 3GPP Organisational Partners and shall not be implemented. This Specification is provided for future development work within 3GPP only. The Organisational Partners accept no liability for any use of this Specification. Specifications and reports for implementation of the 3GPP™ system should be obtained via the 3GPP Organisational Partners' Publications Offices.

Reference

<Workitem>

Keywords

<keyword[, keyword]>

3GPP

Postal address

Office address

Internet

secretariat@3gpp.org

Individual copies of this deliverable
can be downloaded from

<http://www.3gpp.org>

All rights reserved

Copyright Notification

Reproduction is only permitted for the purpose of standardisation work undertaken within xxxx.
The copyright and the foregoing restrictions extend to reproduction in all media.

Xxxxxx...xxx
3GPP

Contents

INTELLECTUAL PROPERTY RIGHTS.....	6
FOREWORD.....	6
1 SCOPE.....	6
2 REFERENCES	6
3 DEFINITIONS, SYMBOLS AND ABBREVIATIONS.....	7
3.1 DEFINITIONS	7
3.2 SYMBOLS.....	7
3.3 ABBREVIATIONS	7
3.4 CDMA EQUATIONS.....	9
3.4.1 BS Transmission Power	9
3.4.2 Rx Signal Strength for UE Not in Handoff (Static propagation conditions)	9
3.4.3 Rx Strength for UE Not in Handoff (Static propagation conditions)	10
3.4.4 Rx Signal Strength for UE in two-way Handover	10
4 GENERAL	12
4.1 MEASUREMENT UNCERTAINTY	12
5 FREQUENCY BANDS AND CHANNEL ARRANGEMENT	13
5.1 GENERAL.....	13
5.2 FREQUENCY BANDS	13
5.3 TX–RX FREQUENCY SEPARATION.....	13
5.4 CHANNEL ARRANGEMENT	13
5.4.1 Channel spacing	13
5.4.2 Channel raster	13
5.4.3 Channel number	13
6 TRANSMITTER CHARACTERISTICS	14
6.1 GENERAL.....	14
6.2 TRANSMIT POWER.....	14
6.2.1 UE maximum output power	14
6.3 FREQUENCY STABILITY.....	14
6.4 OUTPUT POWER DYNAMICS.....	14
6.4.1 Open loop power control	14
6.4.2 Closed loop power control.....	15
6.4.2.1 Closed loop power control in the downlink.....	15
6.4.2.1.1 Minimum requirements.....	15
6.4.3 Power control steps.....	15
6.4.3.1 Minimum requirement.....	15
6.4.4 Minimum transmit output power.....	15
6.4.4.1 Minimum requirement.....	15
6.4.5 Power control cycles per second.....	15
6.5 TRANSMIT ON/OFF POWER	15
6.5.1 Transmit OFF power	15
6.5.1.1 Minimum requirement.....	16
6.5.2 Transmit ON/OFF Time mask	16
6.5.2.1 Minimum requirement.....	16
6.5.3 Transmit DTX.....	16
6.5.3.1 Minimum requirement.....	16
6.6 OUTPUT RF SPECTRUM EMISSIONS	17
6.6.1 Occupied bandwidth	17

6.6.2	Out of band emission	17
6.6.2.1	Spectrum emission mask	17
6.6.2.2	Adjacent Channel Leakage power Ratio (ACLR).....	17
6.6.2.2.1	Minimum requirement	17
6.6.3	Spurious emissions.....	18
6.6.3.1	Minimum requirement	18
6.7	TRANSMIT INTERMODULATION	18
6.7.1	Minimum requirement	18
6.8	TRANSMIT MODULATION	18
6.8.1	Transmit pulse shape filter.....	18
6.8.2	Modulation Accuracy.....	19
6.8.2.1	Minimum requirement.....	19
6.8.3	Peak code Domain error	19
6.8.3.1	Minimum requirement.....	19
7.0	RECEIVER CHARACTERISTICS.....	20
7.1	GENERAL.....	20
7.2	DIVERSITY CHARACTERISTICS	20
7.3	REFERENCE SENSITIVITY LEVEL.....	20
7.3.1	Minimum requirement	20
7.4	MAXIMUM INPUT LEVEL	20
7.4.1	Minimum requirement	20
7.5	ADJACENT CHANNEL SELECTIVITY (ACS).....	21
7.5.1	Minimum requirement	21
7.6	BLOCKING CHARACTERISTICS.....	21
7.6.1	Minimum requirement	21
7.7	SPURIOUS RESPONSE.....	22
7.7.1	Minimum requirement	22
7.8	INTERMODULATION CHARACTERISTICS.....	22
7.8.1	Minimum requirement	23
7.9	SPURIOUS EMISSIONS	23
7.9.1	Minimum requirement	23
8	PERFORMANCE REQUIREMENT	24
	GENERAL.....	24
8.2	DEMULATION IN STATIC PROPAGATION CONDITIONS	24
8.2.1	Demodulation of Paging Channel (PCH).....	24
8.2.1.1	Minimum requirement.....	24
8.2.2	Demodulation of Forward Access Channel (FACH)	24
8.2.2.1	Minimum requirement.....	24
8.2.3	Demodulation of Dedicated Channel (DCH).....	25
8.2.3.1	Minimum requirement.....	25
8.3	DEMULATION OF DCH IN MULTI-PATH PROPAGATION CONDITIONS.....	26
8.3.1	Single Link Performance	26
8.3.1.1	Minimum requirement.....	26
8.4	DEMULATION OF DCH IN MOVING PROPAGATION CONDITIONS	29
8.4.1	Single link performance	29
8.4.1.1	Minimum requirement	29
8.5	DEMULATION OF DCH IN BIRTH-DEATH PROPAGATION CONDITIONS.....	30
8.5.1	Single link performance	30
8.5.1	Minimum requirement.....	30
8.6	HANDOVER PERFORMANCE.....	32
8.6.1	Inter-Cell Soft Handover Performance	32
8.6.1.1	Minimum requirement.....	32
8.6.2	Inter-Frequency Handover	32
8.6.2.1	Minimum requirement.....	33
8.7	TIMING CHARACTERISTICS.....	33
8.7.1	Synchronisation Performance	33
8.7.1.1	Search of other Cells	33
8.7.1.1.1	Minimum requirement	33
8.7.2	Channel Timing Dependencies	33
8.7.2.1	Minimum requirement.....	33

8.7.3	Reception Timing	33
8.7.3.1	Minimum requirement.....	33
ANNEX A (NORMATIVE) MEASUREMENT CHANNELS.....		34
A.1	GENERAL.....	34
A.2	REFERENCE MEASUREMENT CHANNEL	34
A.2.1	UL reference measurement channel.....	34
A.2.2	DL reference measurement channel.....	35
A.3	VOICE MEASUREMENT CHANNEL.....	36
A.4	CIRCUIT SWITCHED DATA MEASUREMENT CHANNEL.....	36
A.5	PACKET SWITCHED DATA MEASUREMENT CHANNEL.....	36
ANNEX B (NORMATIVE): PROPAGATION CONDITIONS		37
B.1	TEST ENVIRONMENTS.....	37
B.2	PROPAGATION CONDITIONS	37
B.2.1	Static propagation condition	37
B.2.2	Multi-path fading propagation conditions.....	37
B.2.3	Moving propagation conditions	38
B.2.4	Birth-Death propagation conditions.....	38
ANNEX C (NORMATIVE): ENVIRONMENTAL CONDITIONS		40
C.1	GENERAL.....	40
C.2	ENVIRONMENTAL REQUIREMENTS	40
C.2.1	Temperature.....	40
C.2.2	Voltage.....	40
C.2.3	Vibration.....	40
ANNEX D (INFORMATIVE): OPEN ITEMS		41
ANNEX E (INFORMATIVE): UE CAPABILITIES (FDD).....		42
E.1	BASELINE IMPLEMENTATION CAPABILITIES	42
E.2	SERVICE IMPLEMENTATION CAPABILITIES	42
HISTORY		43

Intellectual Property Rights

IPRs essential or potentially essential to the present document may have been declared to ETSI. The information pertaining to these essential IPRs, if any, is publicly available for **ETSI members and non-members**, and can be found in ETR 314: “Intellectual Property Rights (IPRs); Essential, or potentially Essential, IPRs notified to ETSI in respect of ETSI standards”, which is available **free of charge** from the ETSI Secretariat. Latest updates are available on the ETSI Web server (<http://www.etsi.fr/ipr>).

Pursuant to the ETSI Interim IPR Policy, no investigation, including IPR searches, has been carried out by ETSI. No guarantee can be given as to the existence of other IPRs not referenced in ETR 314 (or the updates on <http://www.etsi.fr/ipr>) which are, or may be, or may become, essential to the present document.

Foreword

This Technical Specification has been produced by the 3GPP.

The contents of the present document are subject to continuing work within the TSG and may change following formal TSG approval. Should the TSG modify the contents of this TS, it will be re-released by the TSG with an identifying change of release date and an increase in version number as follows:

Version 3.y.z

where:

x the first digit:

3.' presented to TSG for information;

3.' presented to TSG for approval;

3.' Indicates TSG approved document under change control.

Y the second digit is incremented for all changes of substance, i.e. technical enhancements, corrections, updates, etc.

z the third digit is incremented when editorial only changes have been incorporated in the specification;

1 Scope

This document establishes the minimum RF characteristics of the FDD mode of UTRA for the User Equipment (UE).

2 References

The following documents contain provisions, which, through reference in this text, constitute provisions of the present document.

- References are either specific (identified by date of publication, edition number, version number, etc.) or non-specific.
- For a specific reference, subsequent revisions do not apply.
- For a non-specific reference, subsequent revisions do apply.

A non-specific reference to an ETS shall also be taken to refer to later versions published as an EN with the same number.

3 Definitions, symbols and abbreviations

3.1 Definitions

For the purposes of the present document, the following definitions apply:

Power Setting	The value of the control signal, which determines the desired transmitter, output Power. Typically, the power setting would be altered in response to power control commands
Maximum Power Setting	The highest value of the Power control setting which can be used.
Maximum output Power	This refers to the measure of average power at the maximum power setting.
Peak Power	The instantaneous power of the RF envelope which is not expected to be exceeded for [99.9%] of the time
Maximum peak power	The peak power observed when operating at a given maximum output power.
Average transmit power	The average transmitter output power obtained over any specified time interval, including periods with no transmission.
Maximum average power	The average transmitter output power obtained over any specified time interval, including periods with no transmission, when the transmit time slots are at the maximum power setting.

3.2 Symbols

For the purposes of the present document, the following symbols apply:

<symbol> <Explanation>

3.3 Abbreviations

For the purposes of the present document, the following abbreviations apply:

ACIR	Adjacent Channel Interference Ratio
ACLR	Adjacent Channel Leakage power Ratio
ACS	Adjacent Channel Selectivity
BS	Base Station
BER	Bit Error Rate
CW	Continuous Wave (unmodulated signal)
DL	Down Link (forward link)
DTX	
EIRP	Effective Isotropic Radiated Power
FDD	Frequency Division Duplexing
FER	Frame Error Rate
MER	Message Error Rate
PPM	Parts Per Million
RSSI	Received Signal Strength Indicator
SIR	Signal to Interference ratio
TDD	Time Division Duplexing
TPC	Transmit Power Control
UE	User Equipment
UL	Up Link (reverse link)
UTRA	UMTS Terrestrial Radio Access

<i>Chip Rate</i>	Chip rate of W-CDMA system, equals to 4.096 M chips per second.
<i>SCCPCH</i>	Secondary Common Control Physical Channel.
<i>SCCPCH _ E_c</i>	Average energy per PN chip for SCCPCH.
<i>Data _ E_c</i>	Average energy per PN chip for the DATA fields in the DPCH.

$\text{Data} \frac{E_c}{I_o}$	The ratio of the received energy per PN chip for the DATA fields of the DPCH to the total received power spectral density at the UE antenna connector.
$\frac{\text{Data} _ E_c}{I_{or}}$	The ratio of the average transmit energy per PN chip for the DATA fields of the DPCH to the total transmit power spectral density.
DPCH	Dedicated Physical Channel
DPCH $_ E_c$	Average energy per PN chip for DPCH.
$\frac{\text{DPCH} _ E_c}{I_{or}}$	The ratio of the received energy per PN chip of the DPCH to the total received power spectral density at the UE antenna connector.
DCH	Dedicated Channel, which is mapped into Dedicated Physical Channel. DCH contains the data.
E_b	Average energy per information bit for the PCCPCH, SCCPCH and DPCH, at the UE antenna connector.
$\frac{E_b}{N_t}$	The ratio of combined received energy per information bit to the effective noise power spectral density for the PCCPCH, SCCPCH and DPCH at the UE antenna connector. Following items are calculated as overhead: pilot, TPC, TFCI, CRC, tail, repetition, convolution coding and Turbo coding.
E_c	Average energy per PN chip.
$\frac{E_c}{I_{or}}$	The ratio of the average transmit energy per PN chip for different fields or physical channels to the total transmit power spectral density.
FACH	Forward Access Channel
F_{uw}	Frequency of unwanted signal
Information Data Rate	Rate of the user information, which must be transmitted over the Air Interface. For example, output rate of the voice codec.
I_o	The total received power spectral density, including signal and interference, as measured at the UE antenna connector.
I_{oc}	The power spectral density of a band limited white noise source (simulating interference from other cells) as measured at the UE antenna connector.
I_{or}	The total transmit power spectral density of the Forward link at the base station antenna connector.
\hat{I}_{or}	The received power spectral density of the Forward link as measured at the UE antenna connector.
ISCP	Given only interference is received, the average power of the received signal after despreading to the code and combining. Equivalent to the RSCP value but now only interference is received instead of signal.
N_t	The effective noise power spectral density at the UE antenna connector.
OCNS	Orthogonal Channel Noise Simulator, a mechanism used to simulate the users or control signals on the other orthogonal channels of a Forward link.
OCNS $_ E_c$	Average energy per PN chip for the OCNS.
$\frac{\text{OCNS} _ E_c}{I_{or}}$	The ratio of the average transmit energy per PN chip for the OCNS to the total transmit power spectral density.
PCCPCH	Primary Common Control Physical Channel
PCH	Paging Channel
$\text{PCCPCH} \frac{E_c}{I_o}$	The ratio of the received PCCPCH energy per chip to the total received power spectral density at the UE antenna connector.
$\frac{\text{PCCPCH} _ E_c}{I_{or}}$	The ratio of the average transmit energy per PN chip for the PCCPCH to the total transmit power spectral density.
Pilot $_ E_c$	Average energy per PN chip for the Pilot field in the DPCH.
$\text{Pilot} \frac{E_c}{I_o}$	The ratio of the received energy per PN chip for the Pilot field of the DPCH to the total received power spectral density at the UE antenna connector.
$\frac{\text{Pilot} _ E_c}{I_{or}}$	The ratio of the average transmit energy per PN chip for the Pilot field of the DPCH to the total transmit power spectral density.
TFCI $_ E_c$	Average energy per PN chip for the TFCI field in the DPCH.

$TFCI \frac{E_c}{I_o}$	The ratio of the received energy per PN chip for the TFCI field of the DPCH to the total received power spectral density at the UE antenna connector.
$\frac{TFCI_E_c}{I_{or}}$	The ratio of the average transmit energy per PN chip for the TFCI field of the DPCH to the total transmit power spectral density.
RSCP	Given only signal power is received, the average power of the received signal after despreading and combining
TPC_E_c	Average energy per PN chip for the Transmission Power Control field in the DPCH.
$TPC \frac{E_c}{I_o}$	The ratio of the received energy per PN chip for the Transmission Power Control field of the DPCH to the total received power spectral density at the UE antenna connector.
$\frac{TPC_E_c}{I_{or}}$	The ratio of the average transmit energy per PN chip for the Transmission Power Control field of the DPCH to the total transmit power spectral density.

3.4 CDMA Equations

The equations listed below describe the relationship between various parameters under different conditions.

3.4.1 BS Transmission Power

Transmit power of the Base Station is normalized to 1 and can be presented as

$$\frac{PCCPCH_E_c}{I_{or}} + \frac{Pilot_E_c}{I_{or}} + \frac{TPC_E_c}{I_{or}} + \frac{TFCI_E_c}{I_{or}} + \frac{DATA_E_c}{I_{or}} + \frac{SCCPCH_E_c}{I_{or}} + \frac{OCNS_E_c}{I_{or}} = 1.$$

Dedicated Physical Channel consists of four different fields. Therefore, it can be shown that

$$\frac{DPCH_E_c}{I_{or}} = \frac{Pilot_E_c}{I_{or}} + \frac{TPC_E_c}{I_{or}} + \frac{TFCI_E_c}{I_{or}} + \frac{DATA_E_c}{I_{or}}.$$

Hence, transmit power of Base Station can be presented also as

$$\frac{PCCPCH_E_c}{I_{or}} + \frac{DPCH_E_c}{I_{or}} + \frac{SCCPCH_E_c}{I_{or}} + \frac{OCNS_E_c}{I_{or}} = 1.$$

3.4.2 Rx Signal Strength for UE Not in Handoff (Static propagation conditions)

For PCCPCH we get

$$PCCPCH \frac{E_c}{I_o} = \frac{\frac{PCCPCH_E_c}{I_{or}}}{\frac{I_{oc}}{\hat{I}_{or}} + 1}$$

and for a Dedicated Physical Channel

$$DPCH \frac{E_c}{I_o} = \frac{\frac{DPCH_E_c}{I_{or}}}{\frac{I_{oc}}{\hat{I}_{or}} + 1}$$

For the Secondary Common Control Physical Channel we get

$$SCCPCH \frac{E_c}{I_o} = \frac{\frac{SCCPCH_E_c}{I_{or}}}{\frac{I_{oc}}{\hat{I}_{or}} + 1}$$

E_b/N_t for the PCCPCH is given as

$$PCCPCH \frac{E_b}{N_t} = \frac{\frac{PCCPCH - E_c}{I_{or}} \times \frac{\text{Chip Rate}}{\text{Information Data Rate}}}{\frac{I_{oc}}{\hat{I}_{or}}}$$

The same for Dedicated Channels is given as

$$DCH \frac{E_b}{N_t} = \frac{\frac{DPCH - E_c}{I_{or}} \times \frac{\text{Chip Rate}}{\text{Information Data Rate}}}{\frac{I_{oc}}{\hat{I}_{or}}}$$

Similar equations can be derived for the Paging Channel and for the Forward Access Channel. For the Paging Channel we get

$$PCH \frac{E_b}{N_t} = \frac{\frac{SCCPCH - E_c}{I_{or}} \times \frac{\text{Chip Rate}}{\text{Paging Data Rate}}}{\frac{I_{oc}}{\hat{I}_{or}}}$$

and the same for FACH is given as

$$FACH \frac{E_b}{N_t} = \frac{\frac{SCCPCH - E_c}{I_{or}} \times \frac{\text{Chip Rate}}{\text{Control Data Rate}}}{\frac{I_{oc}}{\hat{I}_{or}}}$$

3.4.3 Rx Strength for UE Not in Handoff (Static propagation conditions)

Let us assume that the sum of the channel tap powers is equal to one in multi-path propagation conditions with L taps, i.e.,

$$\sum_{i=1}^L a_i^2 = 1,$$

where a_i represent the complex channel coefficient of the tap i . When assuming that a receiver combines all the multi-paths E_b/N_t for PCCPCH is given as

$$PCCPCH \frac{E_b}{N_t} = \frac{PCCPCH - E_c}{I_{or}} \times \frac{\text{Chip Rate}}{\text{Information Data Rate}} \times \sum_{i=1}^L \frac{a_i^2}{\frac{I_{oc}}{\hat{I}_{or}} + (1 - a_i^2)}$$

As an example E_b/N_t for PCCPCH in Indoor channel is

$$PCCPCH \frac{E_b}{N_t} = \frac{PCCPCH - E_c}{I_{or}} \times \frac{\text{Chip Rate}}{\text{Bearer Data Rate}} \times \left(\frac{0.900824}{\frac{I_{oc}}{\hat{I}_{or}} + 0.099176} + \frac{0.098773}{\frac{I_{oc}}{\hat{I}_{or}} + 0.901227} + \frac{0.000402}{\frac{I_{oc}}{\hat{I}_{or}} + 0.999598} \right)$$

Using the same assumptions, E_b/N_t for Dedicated Channels is given as

$$DCH \frac{E_b}{N_t} = \frac{DPCH - E_c}{I_{or}} \times \frac{\text{Chip Rate}}{\text{Information Data Rate}} \times \sum_{i=1}^L \frac{a_i^2}{\frac{I_{oc}}{\hat{I}_{or}} + (1 - a_i^2)}$$

3.4.4 Rx Signal Strength for UE in two-way Handover

When the received power from each cell is \hat{I}_{or} we get for each PCCPCH Channel

$$PCCPCH \frac{E_c}{I_o} = \frac{\frac{PCCPCH - E_c}{I_{or}}}{\frac{I_{oc}}{\hat{I}_{or}} + 2}$$

If the power received from cell 1 and cell 2 are \hat{I}_{or1} and \hat{I}_{or2} , respectively, then

$$PCCPCH \frac{E_c}{I_o} (\text{Cell 1}) = \frac{\frac{PCCPCH - E_c}{I_{or1}}}{\frac{I_{oc}}{\hat{I}_{or1}} + \frac{\hat{I}_{or2}}{\hat{I}_{or1}} + 1}$$

and

$$PCCPCH \frac{E_c}{I_o} (\text{Cell 2}) = \frac{\frac{PCCPCH - E_c}{I_{or2}}}{\frac{I_{oc}}{\hat{I}_{or2}} + \frac{\hat{I}_{or1}}{\hat{I}_{or2}} + 1}$$

Similarly,

$$DCH \frac{E_b}{N_t} = \frac{DPCH - E_c}{I_{or}} \times \frac{\text{Chip Rate}}{\text{Information Data Rate}} \times \sum_{i=1}^L \frac{2a_i^2}{\frac{I_{oc}}{\hat{I}_{or}} + 1 + (1 - a_i^2)}$$

if the channel is non-static

4 General

4.1 Measurement uncertainty

The requirements given in these specifications are absolute. Compliance with these requirements are determined by comparing the measured values with the specified limits, without making allowance for measurement uncertainty.

5 Frequency bands and channel arrangement

5.1 General

The information presented in this section is based on a chip rate of 4.096 Mcps.

Note

1. Other chip rates may be considered in future releases.

5.2 Frequency bands

UTRA/FDD is designed to operate in either of the following paired bands;

- (a) 1920 – 1980MHz: Up-link (Mobile transmit, base receive)
2110 – 2170MHz: Down-link (Base transmit, mobile receive)

- (b) [FFS; for deployment in ITU Region 2]

Deployment in other frequency bands is not precluded.

5.3 TX–RX frequency separation

- (a) The minimum transmit to receive frequency separation is 134.8 MHz and the maximum value is 245.2 MHz when operating in the paired band defined in sub-clause 5.2 (a). A possible value is 190 MHz
- (b) UTRA/FDD can support both fixed and variable transmit to receive frequency separation. [The specific limits are yet to be determined]
- (c) The use of other transmit to receive frequency separations in other frequency bands shall not be precluded.

5.4 Channel arrangement

5.4.1 Channel spacing

The nominal channel spacing is 5 MHz, but this can be adjusted to optimize performance in a particular deployment scenario.

5.4.2 Channel raster

The channel raster is 200 kHz, which means that the center frequency must be an integer multiple of 200 kHz.

5.4.3 Channel number

The carrier frequency is designated by the UTRA absolute radio frequency channel number (UARFCN)

6 Transmitter characteristics

6.1 General

Unless detailed the transmitter characteristic are specified at the antenna connector of the UE. For UE with integral antenna only, a reference antenna with a gain of 0 dBi is assumed. Transmitter characteristics for UE(s) with multiple antennas/antenna connectors are FFS.

The UE antenna performance has a significant impact on system performance, and minimum requirements on the antenna efficiency are therefore intended to be included in future versions of this specification. It is recognized that different requirements and test methods are likely to be required for the different types of UE.

All the parameters in Section 6 are defined using the UL reference measurement channel specified in Annex A.2.1

6.2 Transmit power

6.2.1 UE maximum output power

The following Power Classes define the maximum output power;

Table 1:UE Power Classes

Power Class	Maximum output power	Tolerance
1	+33 dBm	+1/-3 dB
2	+27 dBm	+1/-3 dB
3	+24 dBm	+1/-3 dB
4	+21 dBm	± 2 dB

Note

- The tolerance of the maximum output power is below the prescribed value even for the multi-code transmission mode

6.3 Frequency stability

The UE modulated carrier frequency shall be accurate to within ± 0.1 PPM compared to carrier frequency received from the BS. These signals will have an apparent error due to BS frequency error and Doppler shift. In the later case, signals from the BS must be averaged over sufficient time that errors due to noise or interference are allowed for within the above ± 0.1 PPM figure.

Table 2: Frequency stability

AFC	Frequency stability
ON	within ± 0.1 PPM

6.4 Output power dynamics

Power control is used to limit the interference level

6.4.1 Open loop power control

Open loop power control is the ability of the UE transmitter to sets its output power to a specific value. The UE open loop power control tolerance is given in Table 3

Table 3: Open loop power control

Normal conditions	± 9 dB
Extreme conditions	± 12 dB

6.4.2 Closed loop power control

Closed loop power control in the Uplink is the ability of the UE transmitter to adjust its output power in accordance with the TPC symbols received in the downlink.

Closed loop power control in the downlink is the ability of the UE receiver to estimate the received SIR, compare it with the SIR target and transmit the TPC symbols in accordance to the results of this comparison.

6.4.2.1 Closed loop power control in the downlink

6.4.2.1.1 Minimum requirements

- (a) The downlink tolerance for the SIR measurements shall be within the range shown in Table 4
- (b) The dynamic range of the SIR measurement of the received signal in the downlink shall be better than shown in Table 4
- (c) The transmitted TPC symbols must respond to a change in the received SIR within the time period specified in Table 4

Table 4: Downlink closed loop power control

SIR measured tolerance	[] dB
SIR dynamic range	[] dB
Time constant for SIR _{sig}	0.625 ms

6.4.3 Power control steps

The power control step is the minimum step change in the UL- transmitter output power in response to a TPC message.

6.4.3.1 Minimum requirement

The UE transmitter shall have the capability of setting the closed loop output power with a step size of 1 dB

- (a) The tolerance of the transmitter output power due to closed loop power control shall be within the range shown in Table 5.
- (b) The greatest average rate of change in mean power shall be greater than 8.0 dB per 10 slots and less than 12.0 dB per 10 slots

Table 5: Transmitter power control tolerance

TPC Symbol in the forward-link	Transmitter power control tolerance	
	Lower	Upper
11	+0.5dB	+1.5 dB
00	-0.5dB	-1.5 dB

6.4.4 Minimum transmit output power

The minimum controlled output power of the UE is when the power control setting is set to a minimum value. This is when both the closed loop and open loop power control indicate a minimum transmit output power is required.

6.4.4.1 Minimum requirement

The minimum transmit power shall be better than -44 dBm /4.096MHz

6.4.5 Power control cycles per second

The maximum rate of change for the UL/DL transmitter power control step.

Up link (UL) 1.6 kHz
Down link (DL) 1.6 kHz

6.5 Transmit ON/OFF power

6.5.1 Transmit OFF power

The transmit OFF power state is when the UE does not transmit except during UL DTX mode. This parameter is defined as the maximum output transmit power within the channel bandwidth when the transmitter is OFF.

6.5.1.1 Minimum requirement

The requirement for the transmit OFF power shall be better than $-50 \text{ dBm} / 4.096 \text{ MHz}$

6.5.2 Transmit ON/OFF Time mask

The time mask for transmit ON/OFF defines the ramping time allowed for the UE between transmit OFF power and transmit ON power. Possible ON/OFF scenarios are RACH or UL slotted mode

6.5.2.1 Minimum requirement

The transmit power levels versus time should meet the mask specified in figure 1

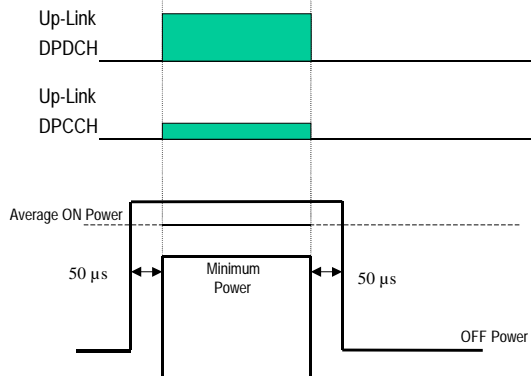

Figure 1: Transmit ON/OFF template

6.5.3 Transmit DTX

DTX is used to minimize the interference between UE(s) by reducing the UE transmit power when voice, user or control information is not present.

6.5.3.1 Minimum requirement

The transmit DTX template is specified when Uplink Dedicated Physical Data Channel (DPDCH) is turned OFF and when the DPDCH is turned ON

Note

With reference to the template specified when the DPDCH is turned OFF (a) and when the DPDCH is turned ON (b)

1. $P_x \text{ [dB]}$ and $P_y \text{ [dB]}$ is the average power of 1slot excluding $50\mu\text{s}$ transient period
2. $P_t \text{ [dB]}$ is the average power during the period of $50\mu\text{s}$ transient
3. $P_y - P_x$ should be within $\pm 2\text{dB}$ of theoretical power change*(excluding 1dB power change due to closed loop power control)
4. P_t should be between P_x and P_y
5. * Theoretical power change is specified by Gain factor β (see 25.213v x.y.z section 4.2.1)

(a) DTX template when DPDCH is turned OFF

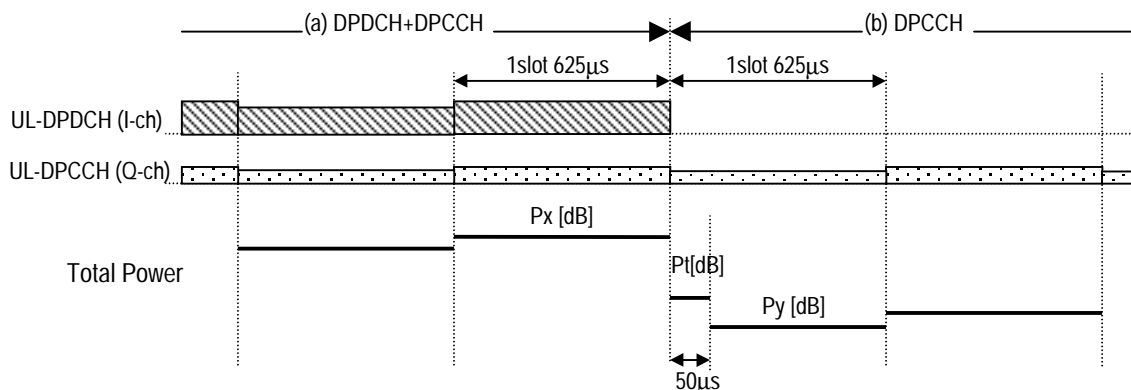

Figure xx1; Uplink Transmit DTX (DPDCH is turned OFF)

Table xx1; the values of Gain Factor β and theoretical power change

	(a) DPDCH+DPCCH	(b) DPCCH
DPDCH Gain	1	0
DPCCH Gain	0.5	0.5
Theoretical power change	-7 dB	

(b) DTX template when DPDCH is turned ON

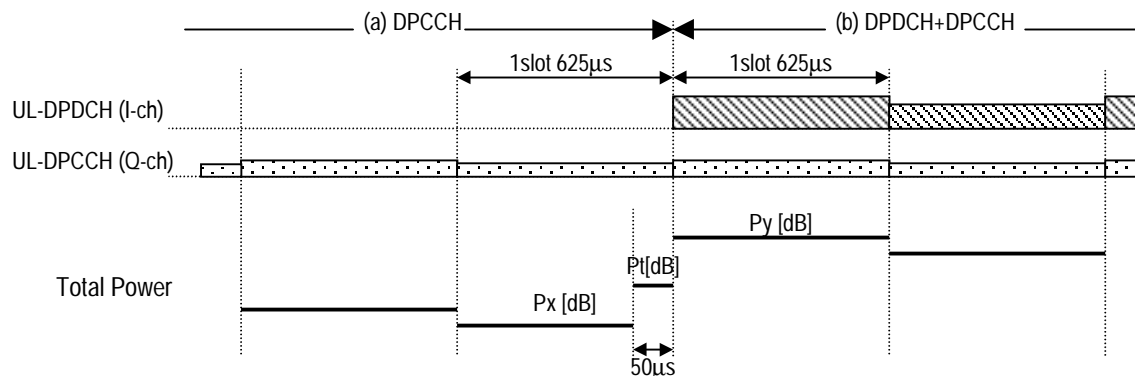

Figure xx2; Uplink Transmit DTX (DPDCH is turned ON)

Table xx2; the values of Gain Factor β and theoretical power change

	(a) DPCCH	(b) DPDCH+DPCCH
DPDCH Gain	0	1
DPCCH Gain	0.5	0.5
Theoretical power change	7 dB	

6.6 Output RF spectrum emissions

6.6.1 Occupied bandwidth

Occupied bandwidth is a measure of the bandwidth containing 99% of the total integrated power of the transmitted spectrum, centered on the assigned channel frequency. The occupied channel bandwidth shall be less than 5 MHz based on a chip rate of 4.096 Mcps.

6.6.2 Out of band emission

Out of band emissions are unwanted emissions immediately outside the [channel] bandwidth resulting from the modulation process and non-linearity in the transmitter but excluding spurious emissions. This out of band emission limit can be specified in terms of a spectrum emission mask or adjacent channel power ratio for the transmitter.

6.6.2.1 Spectrum emission mask

The emission mask will be different for the type of UE(s) and may depend on the power class, single code, multi-code, allocation slotted mode, etc

6.6.2.2 Adjacent Channel Leakage power Ratio (ACLR)

Adjacent Channel Leakage power Ratio (ACLR) is the ratio of the transmitted power to the power measured after a receiver filter in the adjacent channel(s). Both the transmitted power and the received power are measured with a filter that has a Root-Raised Cosine (RRC) filter response with roll-off $\alpha = 0.22$ and a bandwidth equal to the chip rate.

6.6.2.2.1 Minimum requirement

Table 6:UE ACLR

Power Class	UE channel	ACLR limit
4	± 5 MHz	-32 dB or -50dBm/4.096 MHz which ever is higher
4	± 10 MHz	-42 dB or -50 dBm/4.096MHz which ever is higher

Note

1. The ACLR due to switching transients shall not exceed the limits in table 6.
2. The ACLR requirements reflect what can be achieved with present state of the art technology. Requirement on the UE shall be reconsidered when the state of the art technology progresses.

6.6.3 Spurious emissions

Spurious emissions are emissions which are caused by unwanted transmitter effects such as harmonics emission, parasitic emission, intermodulation products and frequency conversion products, but exclude out of band emissions.

The frequency boundary and the detailed transitions of the limits between the requirement for out band emissions and spectrum emissions are based on ITU-R Recommendations SM.329.

6.6.3.1 Minimum requirement

Table 7a: Spurious emissions requirements

Frequency Bandwidth	Resolution Bandwidth	Minimum requirement
$9 \text{ kHz} \leq f < 150 \text{ kHz}$	1 kHz	-36 dBm
$150 \text{ kHz} \leq f < 30 \text{ MHz}$	10 kHz	-36 dBm
$30 \text{ MHz} \leq f < 1000 \text{ MHz}$	100 kHz	-36 dBm
$1 \text{ GHz} \leq f < 12.75 \text{ GHz}$	1 MHz	-30 dBm

Table 7b: Spurious emissions regional requirements

Frequency Bandwidth	Resolution Bandwidth	Minimum requirement
$1893.5 \text{ MHz} < f < 1910 \text{ MHz}$	300 kHz	-40 dBm
$925 \text{ MHz} \leq f \leq 935 \text{ MHz}$	100 kHz	-67 dBm *
$935 \text{ MHz} < f \leq 960 \text{ MHz}$	100 kHz	-79 dBm *
$1805 \text{ MHz} \leq f \leq 1880 \text{ MHz}$	100 kHz	-71 dBm *

* As exceptions, up to five measurements with a level up to -36 dBm are permitted for each ARFCN used in the measurement.

6.7 Transmit intermodulation

The transmit intermodulation performance is a measure of the capability of the transmitter to inhibit the generation of signals in its non linear elements caused by presence of the wanted signal and an interfering signal reaching the transmitter via the antenna.

6.7.1 Minimum requirement

User Equipment(s) transmitting in close vicinity of each other can produce intermodulation products, which can fall into the UE, or BS receive band as an unwanted interfering signal. The UE intermodulation attenuation is defined by the ratio of the output power of the wanted signal to the output power of the intermodulation product when an interfering CW signal is added at a level below the wanted signal. Both the wanted signal power and the IM product power are measured with a filter that has a Root-Raised Cosine (RRC) filter response with roll-off $\alpha = 0.22$ and a bandwidth equal to the chip rate.

The requirement of transmitting intermodulation for a carrier spacing of 5 MHz is prescribed in table 8

Table 8: Transmit Intermodulation

Interference Signal Frequency Offset	5MHz	10MHz
Interference CW Signal Level	-40dBc	
Intermodulation Product	-35dBc / 4.096MHz	-45dBc / 4.096MHz

6.8 Transmit modulation

6.8.1 Transmit pulse shape filter

The transmit pulse-shaping filter is a root-raised cosine (RRC) with roll-off $\alpha = 0.22$ in the frequency domain. The impulse response of the chip impulse filter $RC_0(t)$ is

$$RC_0(t) = \frac{\sin\left(\pi \frac{t}{T_c}(1-\alpha)\right) + 4\alpha \frac{t}{T_c} \cos\left(\pi \frac{t}{T_c}(1+\alpha)\right)}{\pi \frac{t}{T_c} \left(1 - \left(4\alpha \frac{t}{T_c}\right)^2\right)}$$

Where the roll-off factor $\alpha = 0.22$ and the chip duration: $T_c = \frac{1}{\text{chiprate}} = 0.24414\mu\text{s}$

6.8.2 Modulation Accuracy

The modulation accuracy is a measure of the difference between the measured waveform and the theoretical modulated waveform (the error vector). It is the square root of the ratio of the mean error vector power to the mean reference signal power expressed as a %. The measurement interval is one power control group (timeslot)

6.8.2.1 Minimum requirement

The modulation accuracy shall not exceed 17.5 % based on the test parameters detailed in table 9

Table 9: Modulation accuracy

Parameter	Level	Unit
Output power	UE maximum power	dBm

6.8.3 Peak code Domain error

The code domain error is computed by projecting the error vector power onto the code domain at the maximum spreading factor. The error vector for each power code is defined as the ratio to the mean power of the reference waveform expressed in dB. The peak code domain error is defined as the maximum value for the code domain error. The measurement interval is one power control group (timeslot)

The requirement for peak code domain error is only applicable for multi-code transmission.

6.8.3.1 Minimum requirement

The peak code domain error shall not exceed [] dB

7.0 Receiver characteristics

7.1 General

Unless otherwise stated the receiver characteristics are specified at the antenna connector of the UE. For UE(s) with an integral antenna only, a reference antenna with a gain of 0 dBi is assumed. UE with an integral antenna may be taken into account by converting these power levels into field strength requirements, assuming a 0 dBi gain antenna. Receiver characteristics for UE(s) with multiple antennas/antenna connectors are FFS.

The UE antenna performance has a significant impact on system performance, and minimum requirements on the antenna efficiency are therefore intended to be included in future versions of this specification. It is recognized that different requirements and test methods are likely to be required for the different types of UE.

All the parameters in Section 7 are defined using the DL reference measurement channel specified in Annex A.2.2

7.2 Diversity characteristics

A suitable receiver structure using coherent reception in both channel impulse response estimation and code tracking procedures is assumed. Three forms of diversity are considered to be available in UTRA/FDD:

Table 10: Diversity characteristics for UTRA/FDD

Time diversity	Channel coding and interleaving in both up link and down link
Multi-path diversity	Rake receiver or other suitable receiver structure with maximum combining. Additional processing elements can increase the delay-spread performance due to increased capture of signal energy.
Antenna diversity	Antenna diversity with maximum ratio combining in the base station and optionally in the mobile stations. Possibility for downlink transmit diversity in the base station.

7.3 Reference sensitivity level

The reference sensitivity is the minimum receiver input power measured at the antenna port at which the Bit Error Rate (BER) does not exceed a specific value

7.3.1 Minimum requirement

The BER shall not exceed 0.001 for the parameters specified in table 11

Table 11: Test parameters for reference sensitivity

Parameter	Level	Unit
$\frac{P_{CCPCH_Ec}}{I_{or}}$	-1	dB
$\frac{DPCH_Ec}{I_{or}}$	-7	dB
\hat{I}_{or}	-110	dBm/4.096 MHz

7.4 Maximum input level

This is defined as the maximum receiver input power at the UE antenna port which does not degrade the specified BER performance.

7.4.1 Minimum requirement

The BER shall not exceed 0.001 for the parameters specified in table 12

Table 12: Maximum input level

Parameter	Level	Unit
$\frac{PCCPCH_Ec}{I_{or}}$	-10	dB
$\frac{DPCH_Ec}{I_{or}}$	-19	dB
$\frac{OCNS_Ec}{I_{or}}$	-0.52	dB
\hat{I}_{or}	-25	dBm/4.096 MHz

Note

(a) Since the spreading factor is large ($10\log(SF)=21\text{dB}$), the majority of the total input signal consists of the OCNS interference. <Change OCNS definition>

7.5 Adjacent Channel Selectivity (ACS)

Adjacent Channel Selectivity (ACS) is a measure of a receiver's ability to receive a W-CDMA signal at its assigned channel frequency in the presence of an adjacent channel signal at a given frequency offset from the center frequency of the assigned channel. ACS is the ratio of the receive filter attenuation on the assigned channel frequency to the receive filter attenuation on the adjacent channel(s).

7.5.1 Minimum requirement

The ACS shall not exceed the value indicated in Table 13a for the test parameters specified in Table 13b where the BER shall not exceed 0.001

Table 13a: Adjacent Channel Selectivity

Power Class	ACS	Units
4	32	dB

Table 13b: Test parameters for Adjacent Channel Selectivity

Parameter	Level	Unit
$\frac{PCCPCH_Ec}{I_{or}}$	-0.59	dB
$\frac{DPCH_Ec}{I_{or}}$	-9	dB
\hat{I}_{or}	-93	dBm/4.096 MHz
I_{oac}	-52	dBm/4.096 MHz
$F_{uw}(\text{modulated})$	± 5	MHz

7.6 Blocking characteristics

The blocking characteristic is a measure of the receiver's ability to receive a wanted signal at its assigned channel frequency in the presence of an unwanted interferer on frequencies other than those of the spurious response or the adjacent channels, without this unwanted input signal causing a degradation of the performance of the receiver beyond a specified limit. The blocking performance shall apply at all frequencies except those at which a spurious response occur.

7.6.1 Minimum requirement

The BER shall not exceed 0.001 for the parameters specified in table 14 and table 15. For table 15 up to (24) exceptions are allowed for spurious response frequencies in each assigned frequency channel when measured using a 1MHz step size

Table 14: In-band blocking

Parameter	Level	Unit
-----------	-------	------

$\frac{PCCPCH_Ec}{I_{or}}$	-1	dB
$\frac{DPCH_Ec}{I_{or}}$	-7	dB
\hat{I}_{or}	-107	dBm/4.096 MHz
$I_{blocking}$ (modulated)	-44	dBm/4.096 MHz
Blocking offset	>15	MHz

Table 15: Out of band blocking

Parameter	Band 1	Band 2	Unit
$\frac{PCCPCH_Ec}{I_{or}}$	-1	-1	dB
$\frac{DPCH_Ec}{I_{or}}$	-7	-7	dB
\hat{I}_{or}	-107	-107	dBm/4.096 MHz
$I_{blocking}$ (CW)	-30	-15	dBm
Blocking offset	2025 <f <2050 2230 <f <2255	1 < f <2025 2225 < f <12750	MHz

7.7 Spurious response

Spurious response is a measure of the receiver's ability to receive a wanted signal on its assigned channel frequency without exceeding a given degradation due to the presence of an unwanted CW interfering signal at any other frequency at which a response is obtained i.e. for which the blocking limit is not met.

7.7.1 Minimum requirement

The BER shall not exceed 0.001 for the parameters specified in Table 16

Table 16: Spurious Response

Parameter	Level	Unit
$\frac{PCCPCH_Ec}{I_{or}}$	-1	dB
$\frac{DPCH_Ec}{I_{or}}$	-7	dB
\hat{I}_{or}	-107	dBm/4.096 MHz
$I_{blocking}$ (CW)	-44	dBm
fcw	Spurious response frequencies	MHz

7.8 Intermodulation characteristics

Third and higher order mixing of the two interfering RF signals can produce an interfering signal in the band of the desired channel. Intermodulation response rejection is a measure of the capability of the receiver to receive a wanted signal on its assigned channel frequency in the presence of two or more interfering signals which have a specific frequency relationship to the wanted signal.

7.8.1 Minimum requirement

The BER shall not exceed 0.001 for the parameters specified in table 16.

Table 17: Receive intermodulation characteristics

Parameter	Level	Unit
$\frac{PCCPCH_Ec}{I_{or}}$	-1	dB
$\frac{DPCH_Ec}{I_{or}}$	-7	dB
\hat{I}_{or}	-107	dBm/4.096 MHz
I_{ouw1}	-46	dBm
I_{ouw2}	-46	dBm/4.096 MHz
Fuw1 (CW)	10	MHz
Fuw2 (Modulated)	20	MHz

7.9 Spurious emissions

The spurious emissions power is the power of emissions generated or amplified in a receiver that appear at the UE antenna connector.

7.9.1 Minimum requirement

The spurious emission shall be:

- Less than -60 dBm/4.096 MHz at the UE antenna connector, for frequencies within the UE receive band.
- Less than -57 dBm/100 kHz at the UE antenna connector, for frequencies band from 9 kHz to 1 GHz.
- Less than -47 dBm/100 kHz at the UE antenna connector, for frequencies band from 1 GHz to 12.75 GHz.

8 Performance requirement

General

The performance requirements for the UE in this section is specified for the measurement channels specified in Annex A and the test environments specified in Annex B.

8.2 Demodulation in static propagation conditions

8.2.1 Demodulation of Paging Channel (PCH)

The receive characteristics of the paging channel in the static environment is determined by the Paging Message Error Rate (MER). MER is measured at the data rate specified for the paging channel. The UE sleep mode has an upper limit after which it must up wake up and demodulate the paging channel and associated paging messages.

8.2.1.1 Minimum requirement

For the parameters specified in Table 18 the MER shall not exceed the piece-wise linear MER curve specified by the points in Table 19

Table 18 PCH parameters in static propagation conditions

Parameter	Unit	Value
$\frac{PCCPCH_{-}E_c}{I_{or}}$	dB	-10
$\frac{DPCH_{-}E_c}{I_{or}}$	dB	
$\frac{SCCPCH_{-}E_c}{I_{or}}$	dB	
\hat{I}_{or}/I_{oc}	dB	-1
I_{oc}	dBm/4.096 MHz	-60
Paging Data Rate	?	
$PCH E_b/N_t$	dB	

Table 19: PCH requirement in static propagation conditions

$PCH E_b/N_t$	MER
TBD	TBD
TBD	TBD
TBD	TBD

8.2.2 Demodulation of Forward Access Channel (FACH)

The receive characteristics of the Forward Access Channel (FACH) in the static environment are determined by the average message error rate (MER). MER is measured at data rate specified for FACH.

8.2.2.1 Minimum requirement

For the parameters specified in Table 20 the MER shall not exceed the piece-wise linear MER curve specified by the points in table 21

Table 20: FACH parameters in static propagation conditions

Parameter	Unit	Value
$\frac{PCCPCH_E_c}{I_{or}}$	dB	-10
$\frac{DPCH_E_c}{I_{or}}$	dB	
$\frac{SCCPCH_E_c}{I_{or}}$	dB	
\hat{I}_{or}/I_{oc}	dB	-1
I_{oc}	dBm/4.096 MHz	-60
Control Data Rate	?	
$FACH E_b/N_t$	dB	

Table 21: FACH requirements in static propagation conditions

$FACH E_b/N_t$	MER
TBD	TBD
TBD	TBD
TBD	TBD

8.2.3 Demodulation of Dedicated Channel (DCH)

The receive characteristic of the Dedicated Channel (DCH) in the static environment is determined by the average bit error rate (BER). BER is specified for each individual data rate of the DCH. DCH is mapped into the Dedicated Physical Channel (DPCH).

8.2.3.1 Minimum requirement

For the parameters specified in Table 22 the BER shall not exceed the piece-wise linear BER curve specified by the points in table 23

Table 22: DCH parameters in static propagation conditions

Parameter	Unit	Test 1	Test 2	Test 3	Test 4	Test 5	Test 6
$\frac{PCCPCH_E_c}{I_{or}}$	dB	-10	-10	-10	-10	-10	-10
$\frac{DPCH_E_c}{I_{or}}$	dB						
\hat{I}_{or}/I_{oc}	dB	-1					
I_{oc}	dBm/4.096 MHz	-60					
Information Data Rate	kbps	12.2	12.2	64	144	384	2048
Channel Symbol Rate	ksps	32	32	128	256	512	3*1024 ¹
TFCI	-	off	on	on	on	on	on
$DCH E_b/N_t$	dB						

¹ Multi-code transmission with 3 different codes each having 1024 ksps channel symbol rate

Table 23: DCH requirements in static propagation conditions

Test Number	DCH E_b/N_t	BER
1	TBD	TBD
	TBD	TBD
	TBD	TBD
2	TBD	TBD
	TBD	TBD
	TBD	TBD
3	TBD	TBD
	TBD	TBD
	TBD	TBD
4	TBD	TBD
	TBD	TBD
	TBD	TBD
5	TBD	TBD
	TBD	TBD
	TBD	TBD
6	TBD	TBD
	TBD	TBD
	TBD	TBD

8.3 Demodulation of DCH in multi-path propagation conditions

8.3.1 Single Link Performance

The receive characteristics of the Dedicated Channel (DCH) in different multi-path fading environments are determined by the average bit error rate (BER) values. BER is measured for the each of the individual data rate specified for the DPCH. DCH is mapped into in Dedicated Physical Channel (DPCH).

8.3.1.1 Minimum requirement

For the parameters specified in Table 24, 26 and 28 the BER shall not exceed the associated piece-wise linear BER curves specified by the points in Table 25, 27 and 29

Table 24: Test Parameters for DCH in multi-path propagation conditions (Indoor Environment).

Parameter	Unit	Test 1	Test 2	Test 3	Test 4	Test 5	Test 6
$\frac{PCCPCH_E_c}{I_{or}}$	dB	-10	-10	-10	-10	-10	-10
$\frac{DPCH_E_c}{I_{or}}$	dB						
\hat{I}_{or}/I_{oc}	dB						
I_{oc}	dBm/4.096 MHz	-60					
Information Data Rate	kbps	12.2	12.2	64	144	384	2048
Channel Symbol Rate	ksps	32	32	128	256	512	3*1024 ¹
TFCI	-	off	on	on	on	on	on
DCH E_b/N_t	dB						

Table 25: Test requirements for DCH in multi-path propagation conditions (Indoor Environment).

²Multi-code transmission with 3 different codes each having 1024 ksps channel symbol rate

Test Number	$DCH E_b/N_t$	BER
1	TBD	TBD
	TBD	TBD
	TBD	TBD
2	TBD	TBD
	TBD	TBD
	TBD	TBD
3	TBD	TBD
	TBD	TBD
	TBD	TBD
4	TBD	TBD
	TBD	TBD
	TBD	TBD
5	TBD	TBD
	TBD	TBD
	TBD	TBD
6	TBD	TBD
	TBD	TBD
	TBD	TBD

Table 26: DCH parameters in multi-path propagation conditions (Indoor to outdoor and Pedestrian Environment)

Parameter	Unit	Test 7	Test 8	Test 9	Test 10	Test 11	Test 12
$\frac{PCCPCH - E_c}{I_{or}}$	dB	-10	-10	-10	-10	-10	-10
$\frac{DPCH - E_c}{I_{or}}$	dB						
\hat{I}_{or}/I_{oc}	dB						
I_{oc}	dBm/4.096 MHz	-60					
Information Data Rate	kbps	12.2	12.2	64	144	384	2048
Channel Symbol Rate	ksps	32	32	128	256	512	3*1024 ¹
TFCI	-	off	on	on	on	on	on
$DCH E_b/N_t$	dB						

³Multi-code transmission with 3 different codes each having 1024 ksps channel symbol rate

Table 27: DCH requirements in multi-path propagation conditions (Indoor to Outdoor and Pedestrian environment)

Test Number	$DCH E_b/N_t$	BER
7	TBD	TBD
	TBD	TBD
	TBD	TBD
8	TBD	TBD
	TBD	TBD
	TBD	TBD
9	TBD	TBD
	TBD	TBD
	TBD	TBD
10	TBD	TBD
	TBD	TBD
	TBD	TBD
11	TBD	TBD
	TBD	TBD
	TBD	TBD
12	TBD	TBD
	TBD	TBD
	TBD	TBD

Table 28: DCH parameters in multi-path propagation conditions (Vehicular Environment)

Parameter	Unit	Test 13	Test 14	Test 15	Test 16	Test 17	
$\frac{PCCPCH - E_c}{I_{or}}$	dB	-10	-10	-10	-10	-10	
$\frac{DPCH - E_c}{I_{or}}$	dB						
\hat{I}_{or}/I_{oc}	dB						
I_{oc}	dBm/4.096 MHz	-60					
Information Data Rate	kbps	12.2	12.2	64	144	384	
Channel Symbol Rate	ksps	32	32	128	256	512	
TFCI	-	off	on	on	on	on	
$DCH E_b/N_t$	dB						

Table 29: DCH requirements in multi-path propagation conditions (Vehicular Environment)

Test Number	$DCH E_b/N_t$	BER
13	TBD	TBD
	TBD	TBD
	TBD	TBD
14	TBD	TBD
	TBD	TBD
	TBD	TBD
15	TBD	TBD
	TBD	TBD
	TBD	TBD
16	TBD	TBD
	TBD	TBD
	TBD	TBD
17	TBD	TBD
	TBD	TBD
	TBD	TBD

8.4 Demodulation of DCH in moving propagation conditions

8.4.1 Single link performance

The receive single link performance of the Dedicated Traffic Channel (DCH) in dynamic moving propagation conditions are determined by the average Bit Error Rate (BER) values. BER is measured for the each of the individual data rate specified for the DPCH. DCH is mapped into Dedicated Physical Channel (DPCH).

8.4.1.1 Minimum requirement

For the parameters specified in Table 30 the BER shall not exceed the piece-wise linear BER curve specified in points in Table 31

Table 30: DCH parameters in moving propagation conditions (Indoor Environment).

Parameter	Unit	Test 1	Test 2	Test 3	
$\frac{PCCPCH - E_c}{I_{or}}$	dB	-10	-10	-10	
$\frac{DPCH - E_c}{I_{or}}$	dB				
\hat{I}_{or}/I_{oc}	dB	[]			
I_{oc}	dBm/4.096 MHz	-60			
Information Data Rate	kbps	12.2	12.2	64	
Channel Symbol Rate	ksps	32	32	128	
TFCI	-	off	on	on	
$DCH E_b/N_t$	dB				

Table 31: DCH requirements in moving propagation conditions (Indoor Environment)

Test Number	<i>DCH</i> E_b/N_t	BER
1	TBD	TBD
	TBD	TBD
	TBD	TBD
2	TBD	TBD
	TBD	TBD
	TBD	TBD
3	TBD	TBD
	TBD	TBD
	TBD	TBD
4	TBD	TBD
	TBD	TBD
	TBD	TBD

8.5 Demodulation of DCH in birth-death propagation conditions

8.5.1 Single link performance

The receive single link performance of the Dedicated Traffic Channel (DCH) in dynamic birth-death propagation conditions are determined by the average Bit Error Rate (BER) values. BER is measured for the each of the individual data rate specified for the DPCH. DCH is mapped into Dedicated Physical Channel (DPCH).

8.5.1 Minimum requirement

For the parameters specified in Table 33, the BER shall not exceed the piece-wise linear BER curve in the points in Table 34

Table 32: DCH parameters in birth-death propagation conditions (Indoor Environment)

Parameter	Unit	Test 1	Test 2	Test 3	
$\frac{PCCPCH_E_c}{I_{or}}$	dB	-10	-10	-10	
$\frac{DPCH_E_c}{I_{or}}$	dB				
\hat{I}_{or}/I_{oc}	dB	[]			
I_{oc}	dBm/4.096 MHz	-60			
Information Data Rate	kbps	12.2	12.2	64	
Channel Symbol Rate	ksps	32	32	128	
TFCI	-	off	on	on	
$DCH E_b/N_t$	dB				

Table 33: DCH requirements in birth-death propagation conditions (Indoor Environment)

Test Number	$DCH E_b/N_t$	BER
1	TBD	TBD
	TBD	TBD
	TBD	TBD
2	TBD	TBD
	TBD	TBD
	TBD	TBD
3	TBD	TBD
	TBD	TBD
	TBD	TBD

8.6 Handover Performance

8.6.1 Inter-Cell Soft Handover Performance

The bit error rate characteristics of UE is determined during an inter-cell soft handover. During the soft handover a UE receives signals from different Base Stations. A UE has to be able to demodulate two PCCPCH channels and to combine the energy of DCH channels. Delay profiles of signals received from different Base Stations are assumed to be the same but time shifted by 2440 ns (10 chips).

The receive characteristics of the different channels during inter-cell handover are determined by the average bit error rate (BER) values.

8.6.1.1 Minimum requirement

For the parameters specified in Table 34, the BER shall not exceed the piece-wise linear BER curve specified by the points in Table 35

Table 34: DCH parameters in multi-path propagation conditions during Soft Handoff (Vehicular Environment)

Parameter	Unit	Test 1	Test 2	Test 3	Test 4	Test 5
$\frac{PCCPCH - E_c}{I_{or}}$	dB	-10	-10	-10	-10	-10
$\frac{DPCH - E_c}{I_{or}}$	dB					
\hat{I}_{or1}/I_{oc} and \hat{I}_{or2}/I_{oc}	dB					
I_{oc}	dBm/4.096 MHz					
Information Data Rate	kbps	12.2	12.2	64	144	384
Channel Symbol Rate	ksps	32	32	128	256	512
TFCI	-	off	on	on	on	on
$DCH E_b/N_t$	dB					

Table 35 DCH requirements in multi-path propagation conditions during Soft Handoff (Vehicular Environment).

Test Number	$DCH E_b/N_t$	BER
1	TBD	TBD
	TBD	TBD
	TBD	TBD
2	TBD	TBD
	TBD	TBD
	TBD	TBD
3	TBD	TBD
	TBD	TBD
	TBD	TBD
4	TBD	TBD
	TBD	TBD
	TBD	TBD
5	TBD	TBD
	TBD	TBD
	TBD	TBD

8.6.2 Inter-Frequency Handover

The UE has to have the ability to make an Inter-frequency handover. This type of handover can happen within BS or between two BS(s)

8.6.2.1 Minimum requirement

TBD

8.7 Timing characteristics

8.7.1 Synchronisation Performance

8.7.1.1 Search of other Cells

Search for other cells is used to check whether the UE correctly searches and measures other BS(s) during the specified operation.

8.7.1.1.1 Minimum requirement

TBD

Table 36: Test Parameters for the Search of other Cells

Parameter	Unit	Channel 1		Channel 2	
		Time 1	Time 2	Time 1	Time 2
$PCCPCH \frac{E_c}{I_{or}}$	dB				
\hat{I}_{or}/I_{oc}	dB				
I_{oc}	dBm/4.096 MHz	-60			
$PCCPCH \frac{E_c}{I_o}$	dB				

8.7.2 Channel Timing Dependencies

The channel timing of the UE is determined during the specified operation. Relative timing between different code channels transmitted and received at the mobile station. This includes relative frame and slot timing requirements between the forward and reverse links, as well as among different channels.

Possible items to be covered are:

1. Long code timing offsets for each downlink physical channel
2. Requirements for accuracy

8.7.2.1 Minimum requirement

TBD

8.7.3 Reception Timing

The reception timing of the MS is determined during the specified operation.

8.7.3.1 Minimum requirement

TBD

Annex A (normative) Measurement channels

A.1 General

A.2 Reference measurement channel

A.2.1 UL reference measurement channel

The parameters for the UL reference measurement channel are specified in Table A1 and the channel coding is detailed in figure A1

Table A1: UL reference measurement channel

Parameter	Level	Unit
Information bit rate	12.2	Kbps
DPDCH	64	Kbps
DPCCH	16	Kbps
DPCCH/DPDCH	-6	dB
Power control	Off	
TFCI	On	

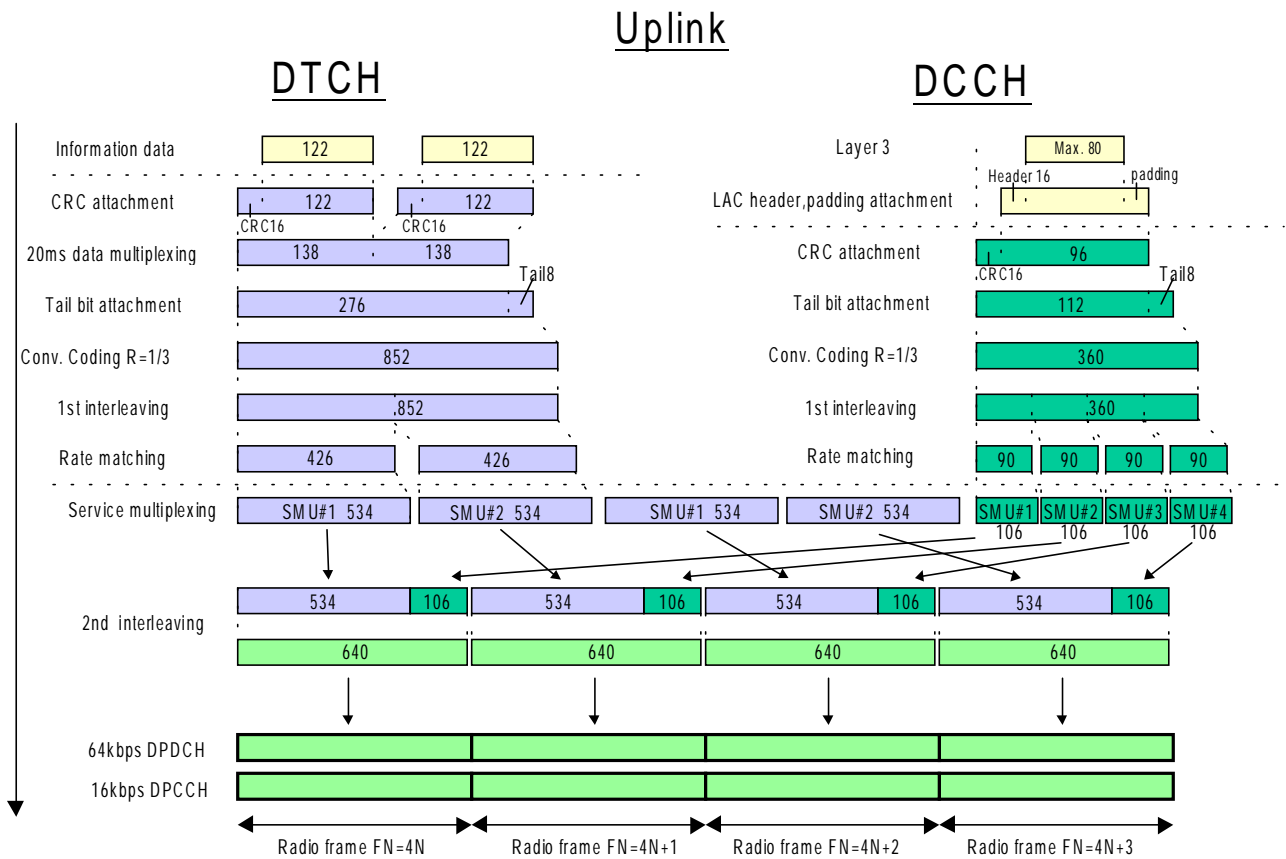

Figure A2: Channel coding of UL reference measurement channel

A.2.2 DL reference measurement channel

The parameters for the DL reference measurement channel are specified in Table A2 and the channel coding is detailed in figure A2

Table A2: DL reference measurement channel

Parameter	Level	Unit
Information bit rate	12.2	Kbps
DPCCH	32	Ksps
Power control	Off	
TFCI	On	

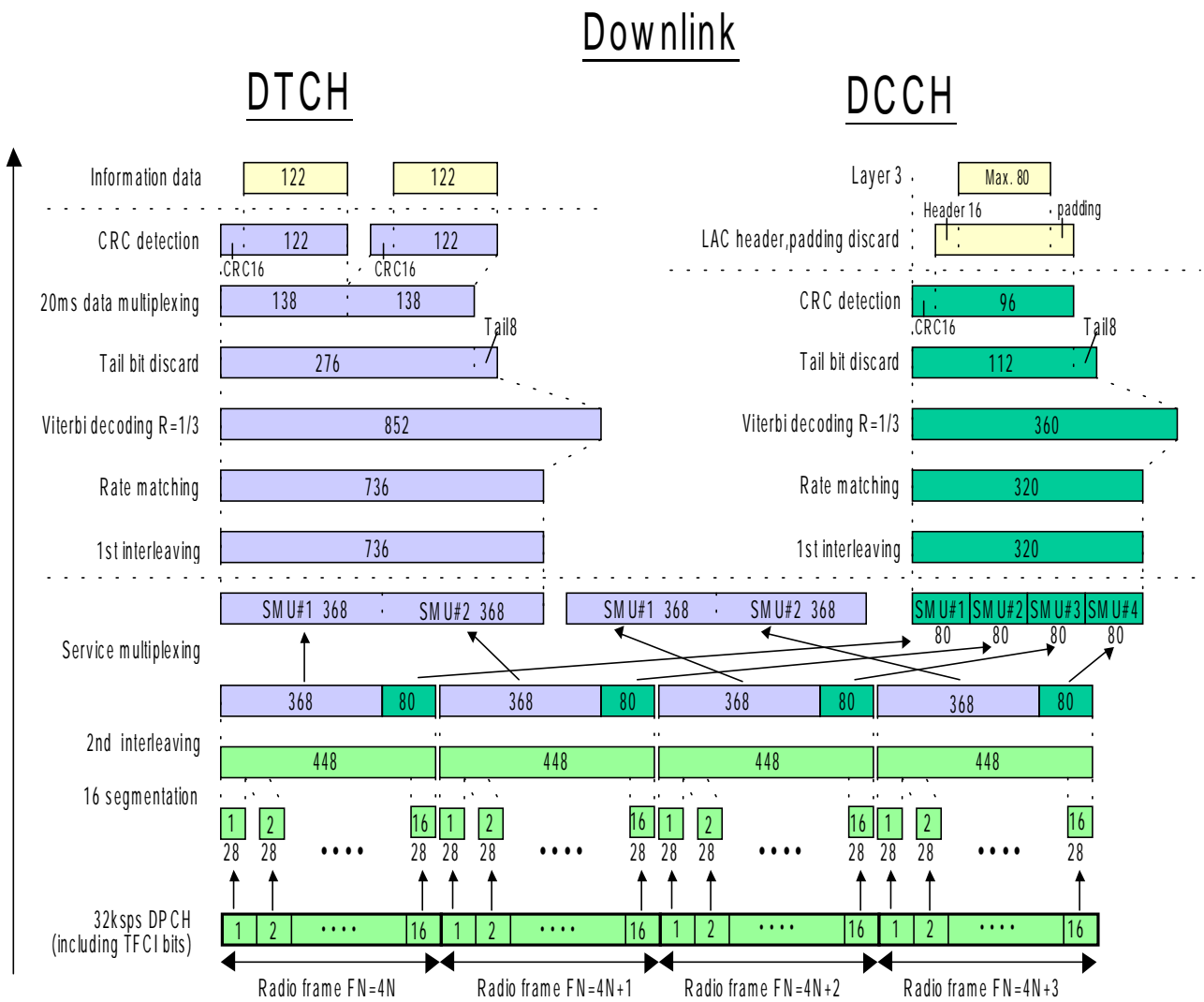

Figure A2: Channel coding of DL reference measurement channel

A.3 Voice measurement channel

The DL channel is based on a 32ksps DPCH including TFCI bits. The UL channel is based on a 64kbps DPDCH and 16kbps DPCCH.

<Both the UL/DL channels coding will need to be revised in accordance with the decisions taken in other parts of 3GPP to accounts of changes to the physical channel structure, channel coding, codec, etc>

A.4 Circuit switched data measurement channel

Figure x and figure y shows the channel coding of DL/UL measurement channel for circuit switched services.

A.5 Packet switched data measurement channel

Figure.x and figure y shows the channel coding of DL/UL measurement channel for packet switched data services.

Annex B (normative): Propagation conditions

B.1 Test Environments

Each of these environments static, indoor, out-door to indoor and pedestrian, and vehicular environments is modeled by typical propagation condition that are defined in this section. These channels may have different bit rates and different BER/FER requirements. Table B1 describes these requirements

Table B1: Test Environments for UE Performance Specifications

Test Services	Static	Indoor Office 3 km/h	Outdoor to Indoor and Pedestrian 3 km/h	Vehicular 120 km/h
	Information Data Rate, Performance metric	Information Data Rate, Performance metric	Information Data Rate, Performance metric	Information Data Rate, Performance metric
Paging Message	128 kbps MER $<10^{-2}$	-	-	-
FACH Message	128 kbps MER $<10^{-2}$	-	-	-
Speech	12.2 kbps BER $<10^{-3}$	12.2 kbps BER $<10^{-3}$	12.2 kbps BER $<10^{-3}$	12.2 kbps BER $<10^{-3}$
Circuit Switched Data	64, 384, 144, 2048 kbps, BER $<10^{-6}$	64, 144, 384 kbps BER $<10^{-6}$	64, 144, 384 kbps BER $<10^{-6}$	64, 144, 384 kbps BER $<10^{-6}$
Packet Switched Data	TBD	TBD	TBD	TBD

B.2 Propagation Conditions

B.2.1 Static propagation condition

The propagation for the static performance measurement is an Additive White Gaussian Noise (AWGN) environment. No fading and multi-paths exist for this propagation model.

B.2.2 Multi-path fading propagation conditions

Modified ITU propagation models¹ are used for the performance measurements in multi-path fading channels. The propagation condition models for indoor, indoor to outdoor and pedestrian, and for vehicular environments are depicted in Table B2

¹ These channel models are the same that were used in simulations and evaluations of the system presented in "Japan's Proposal for Candidate Radio Transmission Technology on IMT-2000, W-CDMA, June 1998"

Table B2: Propagation condition for multi-path fading environments

Case 1 (3 km/h)		Case 2 (3 km/h)		Case 3 (120 km/h)	
Relative Delay [ns]	Average Power [dB]	Relative Delay [ns]	Average Power [dB]	Relative Delay [ns]	Average Power [dB]
0	0.0	0	0.0	0	0.0
244	-9.6	244	-12.5	244	-2.4
488	-33.5	488	-24.7	488	-6.5
				732	-9.4
				976	-12.7
				1220	-13.3
				1708	-15.4
				1952	-25.4

B.2.3 Moving propagation conditions

The dynamic propagation conditions for the test of the baseband performance are non fading channel models with two taps. The moving propagation condition has two tap, one static, Path0, and one moving, Path1. The time difference between the two paths is according Equation (B.1)

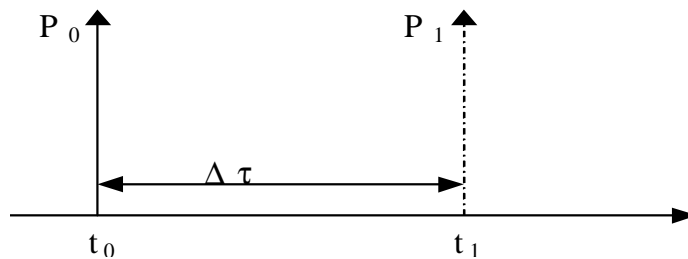
**Figure B1 The moving propagation conditions**

$$\Delta\tau = \left(1 + \frac{A}{2} (1 + \sin(\Delta\omega \cdot t)) \right)$$

The parameters in the equation are shown in.

A	10 μ s
$\Delta\omega$	$20 \cdot 10^{-3} \text{ s}^{-1}$

B.2.4 Birth-Death propagation conditions

The dynamic propagation conditions for the test of the baseband performance is a non fading propagation channel with two taps. The moving propagation conditions has two tap, one static, Path1, and one moving, Path2. The time difference between the two paths is randomly selected with a given rate.

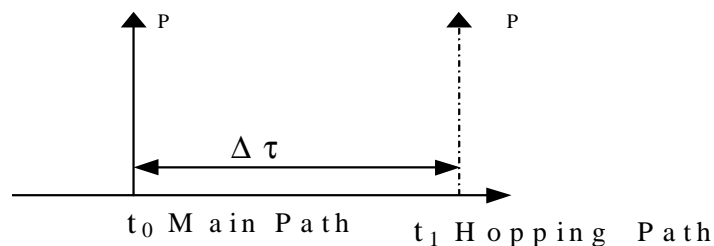
**Figure B2 The delay between path**

The delay $\Delta\tau_1$ between the path is changing every 191 ms. Then every changing point a new time position is chosen randomly among all positions, each with a probability of 1/16.

Table B3 The different path positions and the probability that this position is chosen when the path position is changed.

Δt_i us	Prob(path_I)
-8	0.0625
-7	0.0625
-6	0.0625
-5	0.0625
-4	0.0625
-3	0.0625
-2	0.0625
-1	0.0625
1	0.0625
2	0.0625
3	0.0625
4	0.0625
5	0.0625
6	0.0625
7	0.0625
8	0.0625

Annex C (normative): Environmental conditions

C.1 General

This normative annex specifies the environmental requirements of the UE. Within these limits the requirements of this specifications shall be fulfilled.

C.2 Environmental requirements

The requirements in this clause apply to all types of UE(s)

C.2.1 Temperature

The UE shall fulfil all the requirements in the full temperature range of:

+15°C to +35°C	for normal conditions (with relative humidity of 25 % to 75 %)
-10°C to +55°C	for extreme conditions (see IEC publications 68-2-1 and 68-2-2)

Outside this temperature range the UE, if powered on, shall not make ineffective use of the radio frequency spectrum. In no case shall the UE exceed the transmitted levels as defined in S25.101 for extreme operation.

C.2.2 Voltage

The UE shall fulfil all the requirements in the full voltage range, i.e. the voltage range between the extreme voltages.

The manufacturer shall declare the lower and higher extreme voltages and the approximate shutdown voltage. For the equipment that can be operated from one or more of the power sources listed below, the lower extreme voltage shall not be higher, and the higher extreme voltage shall not be lower than that specified below.

Power source	Lower extreme voltage	Higher extreme voltage	Normal conditions voltage
AC mains	0,9 * nominal	1,1 * nominal	nominal
Regulated lead acid battery	0,9 * nominal	1,3 * nominal	1,1 * nominal
Non regulated batteries:			
- Leclanché / lithium	0,85 * nominal	Nominal	Nominal
- Mercury/nickel & cadmium	0,90 * nominal	Nominal	Nominal

Outside this voltage range the UE if powered on, shall not make ineffective use of the radio frequency spectrum. In no case shall the UE exceed the transmitted levels as defined in S25.101 for extreme operation. In particular, the UE shall inhibit all RF transmissions when the power supply voltage is below the manufacturer declared shutdown voltage.

C.2.3 Vibration

The UE shall fulfil all the requirements when vibrated at the following frequency/amplitudes:

Frequency	ASD (Acceleration Spectral Density) random vibration
5 Hz to 20 Hz	0,96 m ² /s ³
20 Hz to 500 Hz	0,96 m ² /s ³ at 20 Hz, thereafter -3 dB/Octave

Outside the specified frequency range the UE, if powered on, shall not make ineffective use of the radio frequency spectrum. In no case shall the UE exceed the transmitted levels as defined in S25.101 for extreme operation

Annex D (Informative): Open items

Section number	Section description	Status
5.2	Frequency bands	The deployment of TDD in the 1920 MHz to 1980 MHz band is an open item
6.6.2.2	Adjacent Channel Leakage power Ratio (ACLR)	The possibility is being considered of dynamically relaxing the ACLR requirements for User Equipment(s) under conditions when this would not lead to significant interference (with respect to other system scenario or UMTS operators). This would be carried out under network control, primarily to facilitate reduction in UE power consumption.
6.4.3.1	Power control steps minimum requirement	The timing requirement for power control steps is FFS
6.4.3.1	Power control steps minimum requirement	<p>The current text does not cover the case where a power command is a multiple of the step size defined in 6.4.3</p> <p>RAN WG1 is currently;</p> <ul style="list-style-type: none"> • Analyzing the benefits of introduction of smaller step sizes (<1 dB>as an option • Investigating the benefits of emulated step size which imply that changes in the output power occurs at a rate lower than the one defined in 6.4.5
6.7.1	Transmit intermodulation	The minimum requirement will need to be reviewed based on the ACLR requirement.

Annex E (Informative): UE capabilities (FDD)

This section is based on the LS sent to TSG-T2 on baseline terminal capabilities which has been updated to take into account changes in UE radio requirement specifications TS25.101

E.1 Baseline Implementation Capabilities

Table E1: Baseline implementation capabilities

Capability FDD	Section	UE*	Comments
Chip rate 4.096 Mcps	5.1	M	
Frequency bands – 1920-1980, 2110-2170 MHz – Other spectrum	5.2	M O	As Declared
TX-RX Freq. Sep: - 190 MHz - Variable	5.3	M O	As Declared
Carrier raster	5.4	M	
UE maximum output power	6.2.1	M	At least one power class

(* M = mandatory, O = optional)

E.2 Service Implementation Capabilities

For further study.

History

Document history		
V0.0.1	1999-02-01	Merged document from (ARIB) Specification of Mobile Station for 3G Mobile System ver 1.0-1.0) and (ETSI) XX06v0.4.01 UTRA FDD; Radio transmission and reception.
V0.0.2	1999-16-02	First pass merged document presented to meeting
V0.0.3	1999-24-02	2 nd pass merged document incorporating changes from WG4 meeting #2. Sent to reflector for comment.
V1.0.0	1999-24-03	Document status raised to revision v1.0.0 at TSG RAN#2. No Technical or editorial content changes from previous V0.0.3 release apart from change to revision.
V1.1.0	1999-12-04	3 rd release of document incorporating changes from WG4 meeting #3, sent to reflector for comment
TS 25.101 V1.0.0	1999-22-04	Noted by TSG-RAN as TS 25.101 V1.0.0
TS 25.101 V1.2.0	1999-06-02	Document incorporating changes from WG4 meeting #4, sent to reflector for comment
TS 25.101 V2.0.0	1999-06-16	Document approved by WG4 meeting#5 and submitted to TSG RAN meeting #4 (June 1999)

Editor for S25.101 UE Radio transmission and Reception (FDD)

Edgar Fernandes
Motorola Ltd.

Tel: +44 (0) 1256 790168

Fax: +44 (0) 1256 790190

Email: Edgar_Fernandes@europe27.mot.com

This document is written in Microsoft Word 7