

Technical Specification Group, Radio Access Network  
Meeting #2, Fort Lauderdale, 2-4 March 1999

**TSGR#2(99)129**

**Source:** RAN-WG1

**Title:** <S1.21 V0.1.1> Transport channels and physical channels (TDD)

**Document for:**

**Agenda Item:** 7

---

# **3GPP RAN WG1 (S1.21) V0.1.1 1999-02**

---

**3<sup>rd</sup> Generation Partnership Project (3GPP);  
TDD, Transport channels and  
Physical channels description**

---

Reference

xxxx

---

Keywords

**3GPP**

---

Postal address

---

Office address

---

X.400

---

Internet

<http://www.3gpp.org>

---

***Copyright Notification***

No part may be reproduced except as authorized by written permission.  
The copyright and the foregoing restriction extend to reproduction in all media.

© 3GPP 1999.  
All rights reserved.

---

## 0 Content

<b>0</b>	<b>CONTENT</b> .....	<b>3</b>
<b>1</b>	<b>INTELLECTUAL PROPERTY RIGHTS</b> .....	<b>5</b>
<b>2</b>	<b>FOREWORD</b> .....	<b>5</b>
<b>3</b>	<b>SCOPE</b> .....	<b>5</b>
<b>4</b>	<b>REFERENCES</b> .....	<b>5</b>
<b>5</b>	<b>DEFINITIONS AND ABBREVIATIONS</b> .....	<b>5</b>
<b>6</b>	<b>TRANSPORT CHANNELS</b> .....	<b>8</b>
6.1	TRANSPORT CHANNELS.....	8
6.1.1	<i>Dedicated transport channels</i> .....	8
6.1.2	<i>Common transport channels</i> .....	8
<b>7</b>	<b>PHYSICAL CHANNELS</b> .....	<b>9</b>
7.1	FRAME STRUCTURE.....	10
7.2	DEDICATED PHYSICAL CHANNEL (DPCH).....	12
7.2.1	<i>Spreading codes</i> .....	12
7.2.1.1	Multicode transmission with fixed spreading.....	12
7.2.1.2	Single code transmission with variable spreading .....	12
7.2.2	<i>Burst Types</i> .....	12
7.2.2.1	Transmission of TFCI .....	14
7.2.2.2	Coding of TFCI.....	15
7.2.2.3	Burst Structure when using DTX .....	15
7.2.2.4	Transmission of TPC.....	15
7.2.3	<i>Training sequences for spread bursts</i> .....	15
7.2.3.1	Example Midamble Code Set for Burst Type 1 .....	16
7.2.3.2	Example Midamble Code Set for Burst Type 2.....	17
7.2.3.3	Midamble Transmit Power .....	17
7.3	COMMON CONTROL PHYSICAL CHANNELS (CCPCH) .....	17
7.3.1	<i>Downlink common control physical channel</i> .....	17
7.3.1.1	Spreading codes .....	17
7.3.1.2	Burst Types .....	17
7.3.1.3	Training sequences for spread bursts .....	17
7.3.2	<i>The physical random access channel (PRACH)</i> .....	18
7.3.2.1	Spreading codes .....	18
7.3.2.2	Burst Types .....	18
7.3.2.3	Training sequences for access bursts.....	19
7.4	THE PHYSICAL SYNCHRONISATION CHANNEL (PSCH).....	19
<b>8</b>	<b>MAPPING OF TRANSPORT CHANNELS TO PHYSICAL CHANNELS</b> .....	<b>20</b>
8.1	DEDICATED TRANSPORT CHANNELS .....	20
8.2	COMMON TRANSPORT CHANNELS .....	21
8.2.1	<i>The Broadcast Channel (BCH)</i> .....	21
8.2.2	<i>The Paging Channel (PCH)</i> .....	21
8.2.3	<i>The Forward Channel (FACH)</i> .....	21
8.2.4	<i>The Random Access Channel (RACH)</i> .....	21
8.2.5	<i>The Synchronisation Channel (SCH)</i> .....	22
8.2.6	<i>Common Transport Channels for ODMA networks</i> .....	22
8.3	MULTIFRAME STRUCTURE.....	22
<b>9</b>	<b>HISTORY</b> .....	<b>23</b>



## 2 Intellectual Property Rights

---

### 3 Foreword

---

### 4 Scope

---

### 5 References

References may be made to:

- a) specific versions of publications (identified by date of publication, edition number, version number, etc.), in which case, subsequent revisions to the referenced document do not apply;
- b) publications without mention of a specific version, in which case the latest version applies.

A non-specific reference to an ETS shall also be taken to refer to later versions published as an EN with the same number.

- [1] B. Steiner; P. Jung: Uplink channel estimation in synchronous CDMA mobile radio systems with joint detection. The fourth International Symposium on Personal, Indoor and Mobile Radio Communications (PIMRC'93), Yokohama, Japan, September 8-11, 1993.
  - [2] UMTS XX.03 „UTRA FDD, Transport channels and physical channels description”
- 

### 6 Definitions and abbreviations

<Editor's note: This section covers TDD relevant abbreviations only.>

BCH	Broadcast Channel
CCPCH	Common Control Physical Channel
CDMA	Code Division Multiple Access
DPCH	Dedicated Physical Channel
FACH	Forward Access Channel
FDD	Frequency Division Duplex
FEC	Forward Error Correction
GP	Guard Period
GSM	Global System for Mobile Communication
NRT	Non-Real Time
ODCH	ODMA Dedicated Transport Channel
ODMA	Opportunity Driven Multiple Access
ORACH	ODMA Random Access Channel
PCH	Paging Channel
PDU	Protocol Data Unit
PRACH	Physical Random Access Channel
PSCH	Physical Synchronisation Channel
RACH	Random Access Channel
RLC	Radio Link Control
RT	Real Time
RU	Resource Unit
SACCH	Slow Associated Control Channel

SCH	Synchronisation Channel
SDCCH	Stand-alone Dedicated Control Channel
TCH	Traffic Channel
TDD	Time Division Duplex
TDMA	Time Division Multiple Access

## **Status information of ETSI**

### **6 TRANSPORT CHANNELS**

*Working assumption*

### **7 PHYSICAL CHANNELS**

#### 7.1 FRAME STRUCTURE

*Working assumption*

#### 7.2 DEDICATED PHYSICAL CHANNEL (DPCH)

##### 7.2.1 Spreading codes

*Working assumption*

##### 7.2.2 Burst Types

*Working assumption*

###### 7.2.2.1 Transmission of TFCI

*Proposal*

###### 7.2.2.2 Coding of TFCI

*Proposal*

###### 7.2.2.3 Burst Structure when using DTX

*Proposal*

##### 7.2.3 Training sequences for spread bursts

*Working assumption*

#### 7.3 COMMON CONTROL PHYSICAL CHANNELS (CCPCH)

*Downlink common control physical channel*

*Working assumption*

##### 7.3.2 The physical random access channel (PRACH)

*Proposal*

#### 7.4 THE PHYSICAL SYNCHRONISATION CHANNEL (PSCH) #

*Working assumption*

### **8 MAPPING OF TRANSPORT CHANNELS TO PHYSICAL CHANNELS**

*Proposal*

## 8 Transport channels

### 8.1 Transport channels

The chapter describes transport channels that are required for data transfer. Transport channels are the services offered by layer 1 to the higher layers. A general classification of transport channels is into two groups:

- common channels (where there is a need for in-band identification of the UEs when particular UEs are addressed) and
- dedicated channels (where the UEs are identified by the physical channel, i.e. code, time slot and frequency)

#### 8.1.1 Dedicated transport channels

The Dedicated Channel (DCH) is a up- or down-link transport channel that is used to carry user or control information between the network and a mobile station.

? [ *Editors Note : The sentence of DCH is added from ARIB document.* ]

Two types of dedicated transport channels have been identified:

1. Dedicated Channel (DCH) characterized by:

- Existing in uplink or downlink
- possibility to use beam forming,
- possibility to change rate fast (each 10ms),
- enhanced power control and
- inherent addressing of UEs.

? [ *Editors Note : Each bullet point is modified based on TSGR1#2 115.* ]

2. ODMA Dedicated Transport Channel (ODCH) characterized by:

- possibility to use beam forming,
- possibility to change rate fast (each 10ms),
- closed loop power control
- closed loop timing advance control,
- temporary addressing of UEs.

? [ *Editors Note : There is no ODCH in ARIB document. Each bullet point is modified based on TSGR1#2 115.* ]

#### 8.1.2 Common transport channels

Common transport channels are:

1. Broadcast Channel (BCH) characterized by:

- existence in downlink only,
- low fixed bit rate and
- requirement to be broadcasted in the entire coverage area of the cell.

The Broadcast Channel (BCH) is a downlink transport channel that is used to broadcast system- and cell-specific information.

? [ *Editors Note : The sentence of BCH is added from ARIB document.* ]

2. Paging Channel (PCH) characterized by:

- existence in downlink only,
- possibility for sleep mode procedures and
- requirement to be broadcasted in the entire coverage area of the cell.



The Paging Channel (PCH) is a downlink transport channel that is used to carry control information to a mobile station when the system does not know the location cell of the mobile station.

? [ *Editors Note : The sentence of PCH is added from ARIB document. ]*

3. Forward Access Channel(s) (FACH) characterized by:

- existence in downlink only,
- possibility to use beam forming,
- possibility to use slow power control,
- possibility to change rate fast (each 10ms),
- lack of fast power control and
- requirement for in-band identification of UEs.

? [ *Editors Note : The 5th bullet point is added from ARIB document. 3<sup>rd</sup> and 4<sup>th</sup> bullet point are modified based on TSGR1#2 115.]*

The Forward Access Channel (FACH) is a downlink transport channel that is used to carry control information to a mobile station when the system knows the location cell of the mobile station. The FACH may also carry short user packets.

? [ *Editors Note : The sentence of FACH is added from ARIB document. ]*

4. Random Access Channel(s) (RACH) characterized by:

- existence in uplink only,
- limited data field. The exact number of allowed bits is FFS,
- collision risk,
- open loop power control,
- requirement for in-band identification of the UEs.

The Random Access Channel (RACH) is a reverse link transport channel that is used to carry control information from mobile station. The RACH may also carry short user packets.

? [ *Editors Note : The sentence of RACH is added from ARIB document. Second bullet point is added based on TSGR1#2 115. ]*

5. ODMA Random Access Channel (ORACH) characterized by:

- existence in relay links,
- collision risk,
- open loop power control,
- no timing advance control and
- requirement for in-band identification of the MSs.

? [ *Editors Note : There is no ORACH in ARIB document. 4th bullet point is added based on TSGR1#2 115.]*

6. Synchronisation Channel (SCH) characterized by:

- existence in downlink only,
- low fixed bit rate and
- requirement to be broadcasted in the entire coverage area of the cell.

? [ *Editors Note : There is no SCH in ARIB document. In ARIB, SCH is defined as a part of Perch channel as same as common pilot symbols. 1st bullet point is modified based on TSGR1#2 115.]*

---

## 9 Physical channels

All physical channels take three-layer structure of superframes, radio frames, and timeslots. Depending on the resource allocation, the configuration of radio frames or timeslots becomes different. All physical channels need guard symbols in every timeslot. The time slots are used in the sense of a TDMA component to separate different user signals in the time and the code domain. The physical channel signal format is presented in Figure 1.

The basic physical channel is defined as the association of one code, one time slot and one frequency.

? [ Editors Note : There is no figure of three-layer structure in ETSI. The sentence and figure of it are added from ARIB and modified based on TSGR1#2 115. The numbering is aligned with WG2 notation.]

**Figure 1 Physical channel signal format**

## 9.1 Frame structure

The TDMA frame has a duration of 10 ms and is subdivided into 16 time slots (TS) of 625  $\mu$ s duration each. A time slot corresponds to 2560 chips. The physical content of the time slots are the bursts of corresponding length as described in section 0.

? [ Editors Note : There is no definition by the number of chip in ARIB document, because several chip rates are proposed in ARIB. ]

Each 10 ms frame consists of 16 time slots, each allocated to either the uplink or the downlink (Figure 2). With such a flexibility, the TDD mode can be adapted to different environments and deployment scenarios. In any configuration at least one time slot has to be allocated for the downlink and at least one time slot has to be allocated for the uplink.

? [ Editors Note : There is the following differences in the ARIB document.

- First time slot is allocated for downlink
- Multiple-switching-point configuration is supported from a fast power control and transmit space diversity point-of-view.
- All codes within the same timeslot are allocated to exclusively one of the following purpose:
  - 1) UL to Node B
  - 2) DL from Node B
  - 3) ODMA usage

]

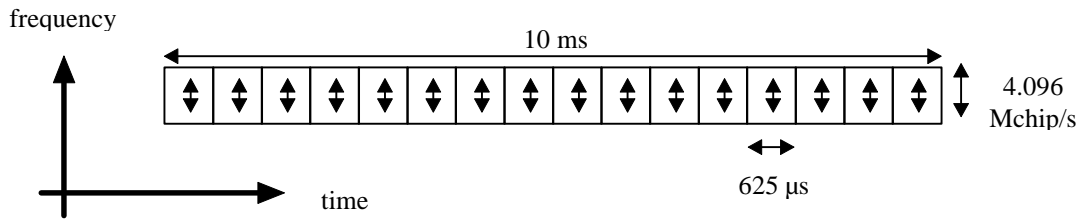

Figure 2 The TDD frame structure

Examples for multiple and single switching point configurations as well as for symmetric and asymmetric UL/DL allocations are given in Figure 3.

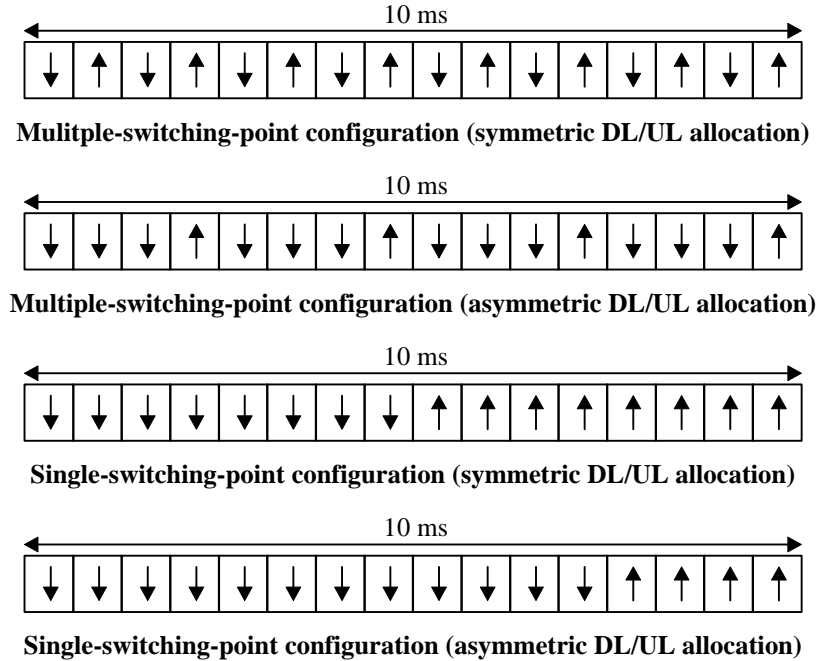

Figure 3 TDD frame structure examples

When operating ODMA at least one common timeslot has to be allocated for the ORACH. If large quantities of information have to be transferred between ODMA nodes then it is normal to use at least one timeslot for the ODCH (Figure 4). As Figure 4 shows, any timeslot in the TDD frame may potentially be used by the ODCH.

Note: a common timeslot indicates a carrier-timeslot combination which can be used for transmission and reception by a group of mobiles operating ODMA.

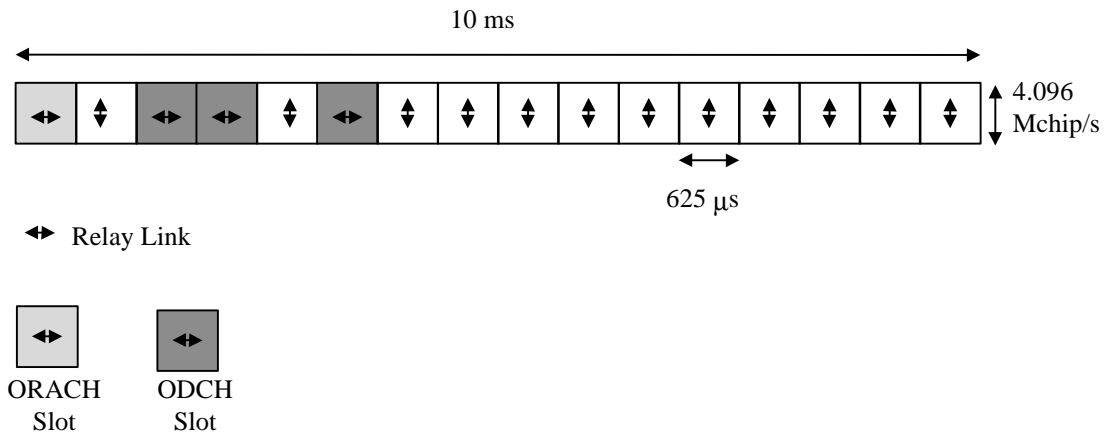

Figure 4 TDD frame structure example for ODMA operation.

? [ Editors Note : There is no ODMA operation and frame structure for ODMA in ARIB document. ]

## 9.2 Dedicated physical channel (DPCH)

The DCH or in case of ODMA networks the ODCH as described in section Dedicated transport channels are mapped onto the dedicated physical channel.

? [ Editors Note : There is no ODCH in ARIB. There is no definition and explanation of DPDCH and DPCCH in ETSI. But these definitions are removed in this text.]

### 9.2.1 Spreading codes

Two options are being considered for the bursts that can be sent as described below. Both options allow a high degree of bit rate granularity and flexibility, thus allowing the implementation of the whole service range from low to high bit rates.

Spreading factor of and the number of codes for multicode transmission are assigned independently for uplink and downlink. The number of timeslots is also assigned independently for uplink and downlink.

? [ Editors Note : There is no description of independent allocation for uplink and downlink in ETSI. ]

#### 9.2.1.1 Multicode transmission with fixed spreading

Within each time slot of length 625  $\mu$ s, an additional separation of user signals by spreading codes is used. This means, that within one time slot of length 625  $\mu$ s, more than one burst of corresponding length as described in section 0 can be transmitted. These multiple bursts within the same time slot can be allocated to different users as well as partly or all to a single user. For the multiple bursts within the same time slot, different spreading codes are used to allow the distinction of the multiple bursts.

The bursts as described in section 0 are designed in such a way, that up to 8 bursts can be transmitted within one time slot, if the bursts are allocated to different users in the uplink. In the downlink or if several bursts in the time slot are allocated to one single user in the uplink, even more than 8 bursts (e.g. 9 or 10) can be transmitted within one time slot.

? [ Editors Note : Multicode transmission is described in section 3.3.6.8.2 as one procedure of multirate transmission and in ARIB. There is no limited number of multiplexed bursts within one time slot in ARIB.]

#### 9.2.1.2 Single code transmission with variable spreading

Within each time slot of 625  $\mu$ s,

- a mobile always uses single code transmission by adapting the spreading factor as a function of the data rate. This limits the peak-to-average ratio of the modulated signal and consequently the stress imposed to the power amplifier resulting in an improved terminal autonomy. Several mobiles can be received in the same time slot by the base station, they are separated by their codes and the individual decoding can take profit of the joint detection.
- a base station should broadcast a single burst per mobile again by adapting the spreading as a function of the data rate. High rate data transmissions requiring more than one timeslot per mobile can be supported by terminals having the processing power for joint detection on a single slot : the required throughput occupies in a general way an integer number of slots plus a fraction of an extra slot. Single burst transmission should occur in the integer number of slots, while the extra slot can be occupied by a burst for the considered mobile plus extra bursts for other mobiles, joint detection is only needed for this last time slot in the considered mobile.

? [ Editors Note : Application of Joint Detection for downlink is still FFS.]

### 9.2.2 Burst Types

? As explained in the section [ Editors Note : There is no ODCH in ARIB. There is no definition and explanation of DPDCH and DPCCH in ETSI. But these definitions are removed in this text.]

9.2.1 Spreading codes, two options are being considered for the spreading. The bursts described in this section can be used for both options.

Two types of bursts for dedicated physical channels are defined: The burst type 1 and the burst type 2. Both

consist of two data symbol fields, a midamble and a guard period. The bursts type 1 has a longer midamble of 512 chips than the burst type 2 with a midamble of 256 chips. Sample sets of midambles are given in section 7.2.3.1 and 7.2.3.2.

Because of the longer midamble, the burst type 1 is suited for the uplink, where up to 8 different channel impulse responses have to be estimated. The burst type 2 can be used for the downlink and, if the bursts within a time slot are allocated to less than four users, also for the uplink.

Thus the burst type 1 can be used for

- uplink, independent of the number of active users in one time slot
- downlink, independent of the number of active users in one time slot

The burst type 2 can be used for

- uplink, if the bursts within a time slot are allocated to less than four users
- downlink, independent of the number of active users in one time slot

The data fields of the burst type 1 are 976 chips long, whereas the data fields length of the burst type 2 are 1104 chips long. The corresponding number of symbols depends on the spreading factor, as indicated in Table 1 below. The guard period for the burst type 1 and type 2 is 96 chip periods long.

The bursts type 1 and type 2 are shown in Figure 5 and Figure 6. The contents of the burst fields are described in Table 2 and Table 3.

**Table 1 number of symbols per data field in bursts 1 and 2**

Spreading factor (Q)	Number of symbols (N) per data field in Burst 1	Number of symbols (N) per data field in Burst 2
1	976	1104
2	488	552
4	244	276
8	122	138
16	61	69

**Table 2 The contents of the burst type 1 fields**

Chip number (CN)	Length of field in chips	Length of field in symbols	Length of field in $\mu\text{s}$	Contents of field
0-975	976	cf Table 1	238.3	Data symbols
976-1487	512	-	125.0	Midamble
1488-2463	976	cf Table 1	238.3	Data symbols
2464-2559	96	-	23.4	Guard period

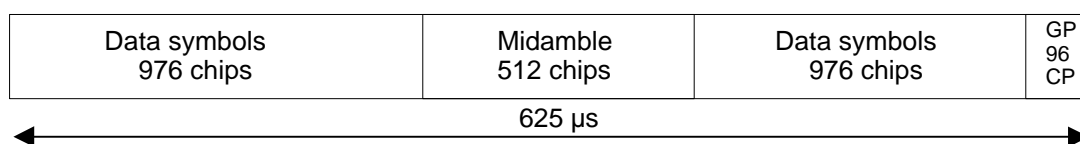

**Figure 5 Burst structure of the burst type 1. GP denotes the guard period and CP the chip periods.**

**Table 3 The contents of the burst type 2 fields**

Chip number (CN)	Length of field in chips	Length of field in symbols	Length of field in $\mu\text{s}$	Contents of field
0-1103	1104	cf Table 1	269.55	Data symbols
1104-1359	256	-	62.5	Midamble
1360-2463	1104	cf Table 1	269.55	Data symbols
2464-2559	96	-	23.4	Guard period

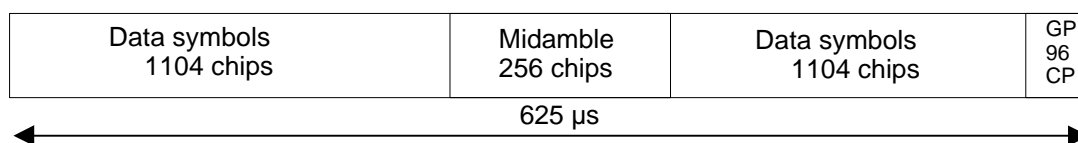

**Figure 6** Burst structure of the burst type 2. GP denotes the guard period and CP the chip periods.

The two different bursts defined here are well-suited for the different applications mentioned above. It may be possible to further optimise the burst structure for specific applications, for instance for unlicensed operation.

### 9.2.2.1 Transmission of TFCI

Both burst types 1 and 2 for dedicated channels provide the possibility for transmission of TFCI both in up- and downlink.

The transmission of TFCI is negotiated at call setup and can be re-negotiated during the call. This means, it is indicated whether the TFCI is applied or not and how many bits are to be allocated for this purpose. If applied, transmission of TFCI is done in the data parts of the traffic burst. Hence the midamble structure and length is not changed. The TFCI information is to be transmitted directly adjacent to the midamble. Figure 7 shows the position of the TFCI in a traffic burst.

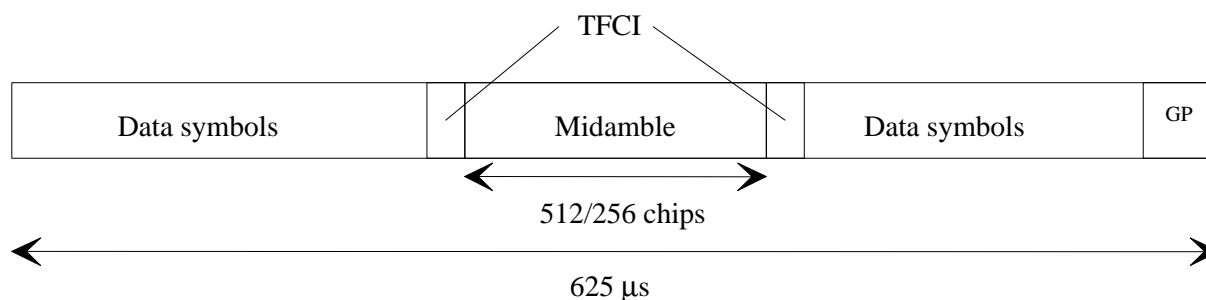

**Figure 7** Position of TFCI information in the traffic burst

For every user the TFCI information is to be transmitted once per frame. Different numbers of symbols can be allocated for TFCI. The TFCI is spread with the same spreading factor (SF) as the data parts. The SF of the burst which contains the TFCI is applied to both data and signalling and shall be constant, except when a negotiation between transmitter and receiver initiates a change of the SF. Variable Data Rates shall be handled by DTX.

Two examples of TFCI transmission in the case of multiple resource units (RUs) used for a connection are given in the Figure 8 and Figure 9 below. Combinations of the two schemes shown are also applicable. It should be noted that the SF can vary for the RUs not carrying TFCI information.

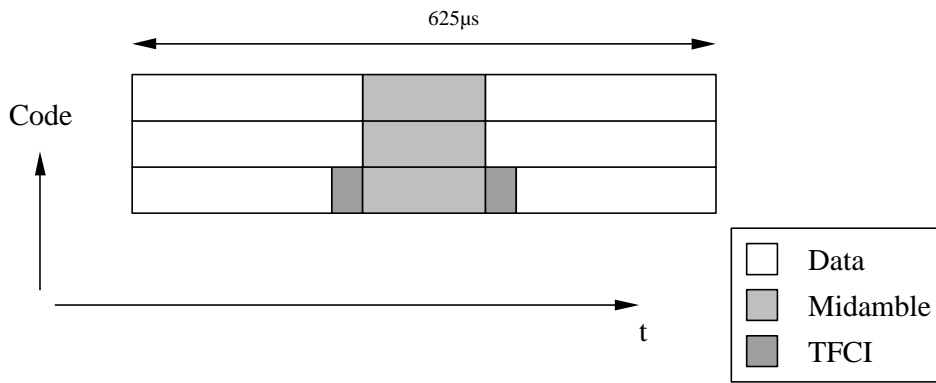

Figure 8 Example of TFCI transmission with RUs multiplexed in code domain

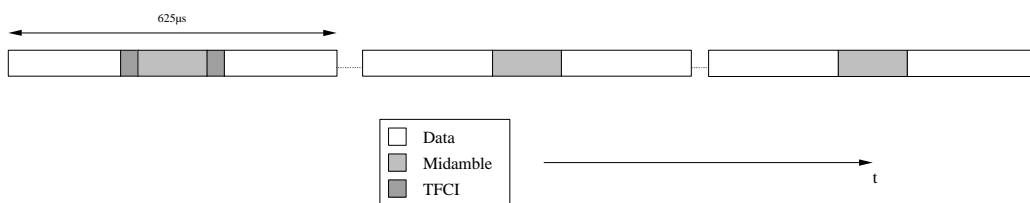

Figure 9 Example of TFCI transmission with RUs multiplexed in time domain

### 9.2.2.2 Coding of TFCI

<to be determined>

### 9.2.2.3 Burst Structure when using DTX

<to be determined>

### 9.2.2.4 Transmission of TPC

<to be determined>

? [ Editors Note : If Open Loop Power Control scheme for uplink is applied to TDD, TPC command may not be needed to be inserted into downlink. ]

## 9.2.3 Training sequences for spread bursts

? [ Editors Note : The same training sequence is described as special scrambling codes (PSC) in section of code generation (3.3.4.2.2) on ARIB. But there is no example midamble code. ]

As explained in the section [ Editors Note : There is no ODCH in ARIB. There is no definition and explanation of DPDCH and DPCCH in ETSI. But these definitions are removed in this text. ]

9.2.1 Spreading codes, two options are being considered for the spreading. The training sequences presented here are common to both options.

The training sequences, i.e. midambles, of different users active in the same time slot are time shifted versions of one single periodic basic code. Different cells use different periodic basic codes, i.e. different midamble sets. In this way a joint channel estimation for the channel impulse responses of all active users within one time slot can be done by one single cyclic correlation. The different user specific channel impulse response estimates are obtained sequentially in time at the output of the correlator. Following this principle it is shown hereafter how to derive the midambles from the periodic basic code.

? Section [ Editors Note : Application of Joint Detection for downlink is still FFS. ]

9.2.2 Burst Types contains a description of the spread speech/data bursts. These bursts contain  $L_m$

midamble chips, which are also termed midamble elements. The  $L_m$  elements  $m_i^{(k)}$ ;  $i=1, \dots, L_m$ ;  $k=1, \dots, K$ ; of the midamble codes  $\underline{\mathbf{m}}^{(k)}$ ;  $k=1, \dots, K$ ; of the  $K$  users are taken from the complex set

$$\underline{\mathbf{V}}_m = \{1, j, -1, -j\}. \quad (1)$$

The elements  $m_i^{(k)}$  of the complex midamble codes  $\underline{\mathbf{m}}^{(k)}$  fulfil the relation

$$m_i^{(k)} = (j)^i \cdot m_i^{(k)} \quad m_i^{(k)} \in \{1, -1\}; \quad i = 1, \dots, L_m; \quad k = 1, \dots, K. \quad (2)$$

Hence, the elements  $m_i^{(k)}$  of the complex midamble codes  $\underline{\mathbf{m}}^{(k)}$  of the  $K$  users are alternating real and imaginary.

With  $W$  being the number of taps of the impulse response of the mobile radio channels, the  $L_m$  binary elements  $m_i^{(k)}$ ;  $i = 1, \dots, L_m$ ;  $k = 1, \dots, K$ ; of (2) for the complex midambles  $\underline{\mathbf{m}}^{(k)}$ ;  $k=1, \dots, K$ ; of the  $K$  users are generated according to Steiner's method [1] from a single periodic basic code

$$\mathbf{m} = (m_1, m_2, \dots, m_{L_m + (K-1)W})^T \quad m_i \in \{1, -1\}; \quad i = 1, \dots, (L_m + (K-1)W). \quad (3)$$

The elements  $m_i$ ;  $i = 1, \dots, (L_m + (K-1)W)$ , of (3) fulfil the relation

$$m_i = m_{i-P} \quad \text{for the subset} \quad i = (P+1), \dots, (L_m + (K-1)W). \quad (4)$$

The  $P$  elements  $m_i$ ;  $i = 1, \dots, P$ , of one period of  $\mathbf{m}$  according to (3) are contained in the vector

$$\mathbf{m}_p = (m_1, m_2, \dots, m_p)^T. \quad (5)$$

With  $\mathbf{m}$  according to (3) the  $L_m$  binary elements  $m_i^{(k)}$ ;  $i = 1, \dots, L_m$ ;  $k = 1, \dots, K$ ; of (2) for the midambles of the  $K$  users are generated based on Steiner's formula

$$m_i^{(k)} = m_{i+(K-k)W} \quad i = 1, \dots, L_m; \quad k = 1, \dots, K. \quad (6)$$

In the following the term 'a midamble code set' or 'a midamble code family' denotes  $K$  specific midamble codes  $\underline{\mathbf{m}}^{(k)}$ ;  $k=1, \dots, K$ . Different midamble code sets  $\underline{\mathbf{m}}^{(k)}$ ;  $k=1, \dots, K$ ; are in the following specified based on different periods  $\mathbf{m}_p$  according (5).

In adjacent cells of the cellular mobile radio system, different midamble codes sets  $\underline{\mathbf{m}}^{(k)}$ ;  $k=1, \dots, K$ ; should be used to guarantee a proper channel estimation.

As mentioned above a single midamble code set  $\underline{\mathbf{m}}^{(k)}$ ;  $k=1, \dots, K$ ; consisting of  $K$  midamble codes is based on a single period  $\mathbf{m}_p$  according to (5).

In the following several exemplary periods  $\mathbf{m}_p$  according (5) which can be used to generate different midamble code sets  $\underline{\mathbf{m}}^{(k)}$ ;  $k=1, \dots, K$ ; will be listed in tables in a hexadecimal representation. As shown in Table 4 always 4 binary elements  $m_i$  are mapped on a single hexadecimal digit.

**Table 4 Mapping of 4 binary elements  $m_i$  on a single hexadecimal digits**

4 binary elements $m_i$	mapped on hexadecimal digit
-1 -1 -1 -1	0
-1 -1 -1 1	1
-1 -1 1 -1	2
-1 -1 1 1	3
-1 1 -1 -1	4
-1 1 -1 1	5
-1 1 1 -1	6



-1 1 1 1	7
1 -1 -1 -1	8
1 -1 -1 1	9
1 -1 1 -1	A
1 -1 1 1	B
1 1 -1 -1	C
1 1 -1 1	D
1 1 1 -1	E
1 1 1 1	F

The mean degradations [2, equation (38)] which serve as a quality information of the periods  $\mathbf{m}_p$  according to (5) and hence of the specified midamble code sets  $\underline{\mathbf{m}}^{(k)}$ ;  $k=1, \dots, K$ ; will be also given.

### 9.2.3.1 Example Midamble Code Set for Burst Type 1

In the case of burst type 1 (see section [ *Editors Note : Application of Joint Detection for downlink is still FFS.*]

9.2.2 Burst Types) the midamble has a length of  $L_m=512$ , which is corresponding to:

$K=8$ ;  $W=57$ ;  $P=456$

Table 5 Example Periods  $\mathbf{m}_p$  according (8-5) for case of burst type 1.

Periods $\mathbf{m}_p$ of length $P=456$	Degradation in dB
C482462CA7846266060D21688BA00B72E1EC84A3D5B7194C8DA39E21A3CE12BF512C8AAB6A7079F73C0D3E4F40AC555A4BCC453F1DFE3F6C82	0.649471
56F3ACE0A65B96FC326A30B91665BD4380907C2B08DEC98C16A0B0339AEA855C3D8BDD016E4C3E0F3DA5DF5C0891C851BA30A6C19ABE6C3ED4	0.695320
1D566C76440333CBF3CA2A05386068E19A2D6A53560CC50138B3A15BF7D9683F95F66FF096431363E09A514D61099DD3EAD52903BF4A27D14	0.705751
9A0A349E49389CC184F7A3420D3FBE06B3A40BEE933D8E04E61FAA4A5214D918A1ADD5BE25D833579FBCF17B422300D0CA1B419393F9722AA8	0.706513
B760E5694E49169C225A2FBCDACCCA8847F8486A6A351EB7D045BA2271B2A4CB900404C0D2BBA00F80F963861BD7DCE748F0F10AE6B785D0F0	0.707417
ECE93B83CE32E395405F7C889751970E84AFD632500B91E17C4E7846FE68D3C8410135D3114D3281211214D1F5F1996A6B656259F11728AA52	0.708587
DE1B6F6219A0AD1A3EB5EEA02173D704C3340AAE7310B93A21BCF979BC7B6C0817003AA300B1704BCE62524EC48C505977A1570F6C6BA1A2D8	0.711320

### 9.2.3.2 Example Midamble Code Set for Burst Type 2

In the case of burst type 2 (see section [ *Editors Note : Application of Joint Detection for downlink is still FFS.*]

9.2.2 Burst Types) the midamble has a length of  $L_m=256$ , which is corresponding to:

$K=3$ ;  $W=64$ ;  $P=192$

Table 6 Example Periods  $\mathbf{m}_p$  according (8-5) for case of burst type 2.

Periods of length $P=192$	Degradation in dB
D4A124FE4D11BC14C258546A18C5DE0E3AA3F0617245DBFE	0.615566
48D76A687E21D22321C5201977F620D7A4CB5945F5693A1C	0.638404
9EEF5E79606DCAAB046769524691E09E816DC688ABC12030	0.663436
D2369A2B704878F55B58A300C853A2F62233E6207E39F944	0.677739
A26C7D9697B002714E9285D2AFC3AF1E233FC8C6C7486080	0.686287
8A615F5D7EE05668415E626482E90B11C95305E4707015B5	0.686660
5CC2D7409922FA463D2D14377EBCF0CC0E888426B06F0A82	0.688977
A68238D5BD37B2B4C48B466B9815087898409AF0CB804FA0B	0.692613

### 9.2.3.3 Midamble Transmit Power

In the case of the downlink, 2K data blocks are transmitted in a burst simultaneously. Also in the uplink, if K' greater than one CDMA code are assigned to a single user, 2K' data blocks are transmitted in a burst simultaneously by this user. This is the so called multi-code uplink situation. In the downlink and the multi-code uplink, the mean power used to transmit the midambles on the one hand and the 2K (or 2K') data blocks on the other hand shall be equal. This shall be achieved by multiplying the midamble codes  $\underline{m}^{(k)}$ ,  $k=1, \dots, K$ , with a proper real factor to achieve an attenuation or an amplification.

## 9.3 Common control physical channels (CCPCH)

### 9.3.1 Downlink common control physical channel

Either the BCH, the PCH or the FACH as described in section 0 [ *Editors Note : There is no ODCH in ARIB document. Each bullet point is modified based on TSGR1#2 115.*]

8.1.2 Common transport channels are mapped onto one or more downlink common control physical channels (CCPCH). In such a way the capacity of BCH, PCH and FACH can be adopted depending on the operators need.

#### 9.3.1.1 Spreading codes

The downlink CCPCH uses fixed spreading with a spreading factor SF = 16 as described in section 0.

#### 9.3.1.2 Burst Types

The bursts as described in section 0 are used for the downlink CCPCH.

#### 9.3.1.3 Training sequences for spread bursts

The training sequences, i.e. midambles, as described in section 0 are used for the downlink CCPCH.

### 9.3.2 The physical random access channel (PRACH)

The RACH or in case of ODMA networks the ORACH as described in section 0 are mapped onto one or more uplink physical random access channels (PRACH). In such a way the capacity of RACH and ORACH can be adopted depending on the operators need.

#### 9.3.2.1 Spreading codes

The uplink PRACH uses fixed spreading with a spreading factor SF = 16 as described in section 0.

#### 9.3.2.2 Burst Types

? [ *Editors Note : The detailed schemes concerning round trip delay and delay spread are FFS. Tdoc100/99 shows the more details of items for further study.*]

The mobiles send the uplink access bursts randomly in the uplink PRACH. This leads to time-divided collision groups. The usage of up to 8 orthogonal codes per time slot increases the amount of collision groups and throughput, respectively.

A further improvement is achieved by using two distinct access bursts, which can both be transmitted within one time slot without collision. Access burst 1 uses only the first half of a time slot, access burst 2 the second. Both access bursts are depicted in Figure 10 and Figure 11, respectively. The contents of the access burst fields are listed in Table 7 and Table 8.

**Table 7 The contents of the access burst 1 fields**

Chip Number (CN)	Length of field in chips	Length of field in symbols	Length of field in $\mu\text{s}$	Contents of field
0-335	336	21	82.0	Data symbols
336-847	512	-	125.0	Midamble
848-1183	336	21	82.0	Data symbols
1184-1279	96	-	23.4	Guard period
1279-2559	1280	-	312.5	Extended guard period



**Figure 10 Access burst 1, GP denotes the guard period**

**Table 8 The contents of the access burst 2 fields**

Chip Number (CN)	Length of field in chips	Length of field in symbols	Length of field in $\mu\text{s}$	Contents of field
0-1279	1280	-	312.5	Extended guard period
1280-1615	336	21	82.0	Data symbols
1616-2127	512	-	125.0	Midamble
2128-2463	336	21	82.0	Data symbols
2464-2559	96	-	23.4	Guard period

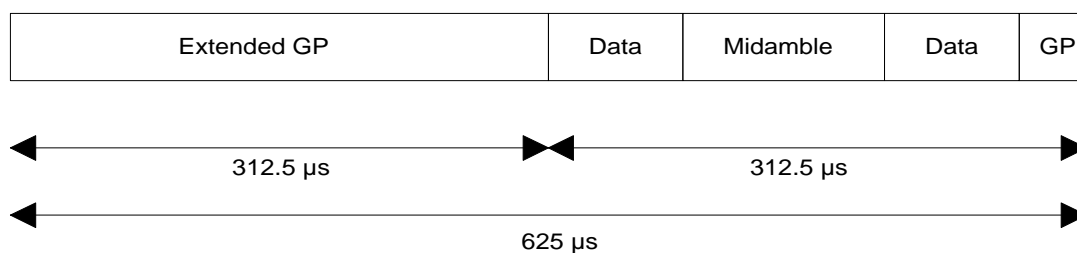

**Figure 11 Access burst 2, GP denotes the guard period**

### 9.3.2.3 Training sequences for access bursts

The training sequences, i.e. midambles, as described in section 0 are used for the uplink PRACH.

? [ Editors Note : This training sequence is described as special scrambling codes (PSC) of option in ARIB.]

## 9.4 The physical synchronisation channel (PSCH)

? [ Editors Note : The detailed scheme of CCCH pointing by SCH is FFS.]

The PSCH is similar to the FDD SCH. In order not to limit the UL/DL asymmetry the PSCH is mapped on one or two DL slots per frame only.

There are three cases of SCH and CCCH allocation as follows:

Case 1) SCH and CCCH allocated in TS#k,  $k=0\dots15$

Case 2) SCH in two TS and CCCH in the same two TS: TS#k and TS#k+8,  $k=0\dots7$

Case 3) SCH in two TS, TS#k and TS#k+8,  $k=0\dots7$ , and the primary first CCCH TS#i,  $i=0\dots15$ , pointed by SCH

The position of SCH (value of k) in frame can change on a long term basis in any case.

Figure 12 is one example,  $k=0$ , of Case 2 or Case 3. In this case, the PSCH uses system-wide always the same two DL slots, which are slot 0 and slot 8.

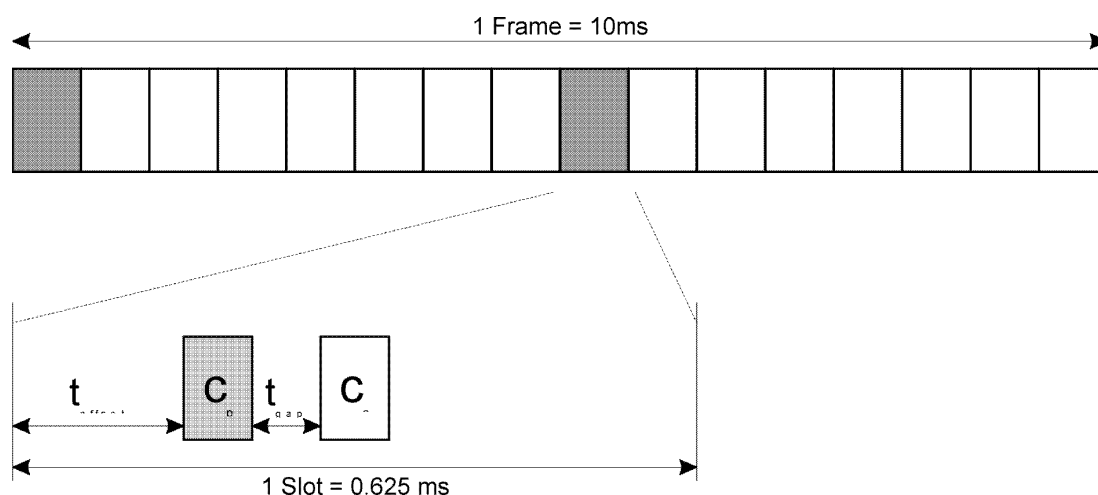

Figure 12 Scheme for Synchronisation channel SCH consisting of one primary sequence  $C_p$  and one secondary sequence  $C_s$  per slot (example of Case 2 or Case 3)

As depicted in Figure 12, the PSCH consists of a primary and secondary code sequence with 256 chips length of spreading factor less or equal to 16. The used sequences  $C_p$  and  $C_s$  are the same as in FDD-Mode, see [2].

The time offset  $t_{gap}$  is the time between the primary synchronisation code and the secondary synchronisation code. It provides enough time for calculations and a better interference distribution, since the codes do not superimpose. The exact value is to be determined.

Due to mobile to mobile interference, it is mandatory for public TDD systems to keep synchronisation between base stations. As a consequence of this, a capture effect concerning PSCH, see explanation below, can arise. The time offset  $t_{offset}$  enables the system to overcome the capture effect.

When searching for synchronisation engaging  $C_p$  a situation as outlined in Figure 13 may occur. The correlations, which are shown separately in the figure, superimpose at the mobile's receiver. The introduction of  $t_{offset}$  will ease the detection of cell 3. Since different cells use different time offsets, the time offset  $t_{offset}$  enables the receiver to detect even cells with low correlation peaks, as there is additional separation in time-domain. The cell's specific time offset  $t_{offset}$  is obtained by decoding the SCH.

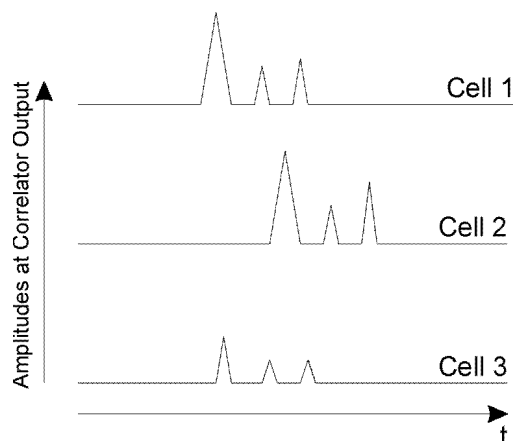

Figure 13 Sample for capturing effect whilst detecting synchronised Base Stations

## 10 Mapping of transport channels to physical channels

This section describes the way in which transport channels are mapped onto physical resources, see Figure 14. A description of the multiframe structure is given in section 8.3.

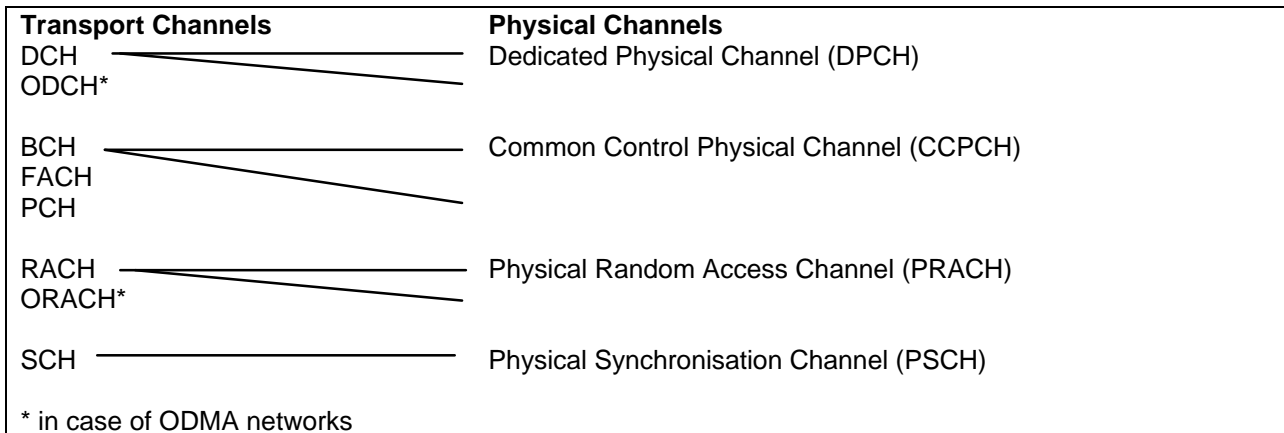

Figure 14 Transport channel to physical channel mapping

In the sequel, we use the terms physical channel and resource unit (RU); a physical channel is defined as the association of one code, one time slot and one frequency. A resource unit (RU) is that part of a physical channel allocated for one frame.

### 10.1 Dedicated Transport Channels

A dedicated transport channel is mapped onto one or more sets of slots and codes within a frame. An interleaving period is associated with each allocation. The frame is subdivided into slots that are available for uplink and downlink information transfer. Each set of slots and codes over an interleaving period maps to a data unit and a data unit can correspond to one or more FEC code blocks and one or more RLC protocol data units dependent from the service being supported. The mapping is illustrated by the following diagram (Figure 15):

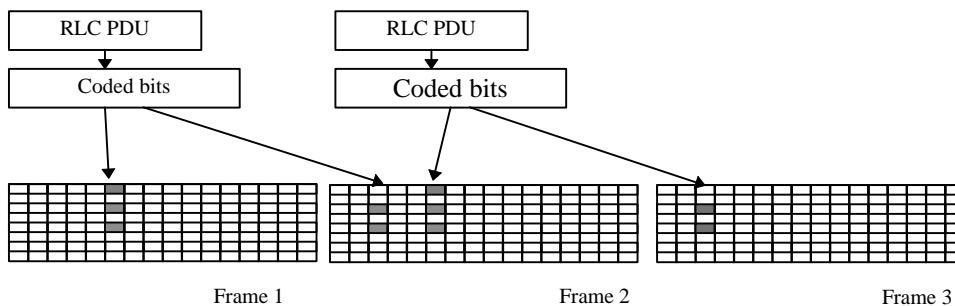

Figure 15 Mapping of PDU onto the physical bearer

For NRT packet data services an allocation is made only for a relatively short period of time. In general, for RT services an allocation is made for a certain time period and a release procedure is necessary to release the resource. For the efficient use of resources the slot/ code set allocated to a radio bearer may be changed from time to time and the resources allocated to a VBR service may increase or decrease along with the changes in the data rate. Traffic channels are power controlled.

An ODCH is also mapped onto one or more sets of slots and codes within a TDD frame as shown in Figure 6. The actual transmission mode (i.e. combination of slots, codes, TX power, interleaving depth etc.) chosen for a relay link will be negotiated between nodes prior to transmission. Several of these transmission mode parameters can be adapted during transmission due to changes in propagation and data traffic.

## 10.2 Common Transport Channels

### 10.2.1 The Broadcast Channel (BCH)

? [ *Editors Note : The detailed scheme of CCCH pointing by SCH is FFS.* ]

The BCH is mapped on one or several RU per frame. The secondary SCH indicates in which timeslot and code group a mobile can find the BCH. If the BCH uses more than one RU, the secondary SCH comprises a pointer to the whole BCH mapping scheme or only to the primary BCH RU and this comprises a pointer to secondary BCH RU. The BCH has a reference power level. The RU allocated by BCH can be shared with other common control channels, e.g. PCH or FACH, according to a multi-frame structure.

### 10.2.2 The Paging Channel (PCH)

The PCH can be mapped onto any combination of time slots and codes so that capacity can be matched to requirements. The location of the PCH is indicated on the BCH. The PCH has to allow an efficient DRX. It is always transmitted at a reference power level.

### 10.2.3 The Forward Channel (FACH)

The FACH can be mapped onto any combination of downlink resource units. The location of the FACH is indicated on the BCH and both, capacity and location can be changed, if required. FACH may or may not be power controlled.

### 10.2.4 The Random Access Channel (RACH)

The RACH has an interleaving period of one frame and each transmission occupies only one burst. To accommodate RACH a single uplink slot is subdivided into two sub-slots each capable of supporting independent transmissions of one burst. The same slot may be used for RACH by more than one cell. Multiple transmissions using different codes may be received in parallel. If needed more than one slot may be administrated for the RACH. The location of slots allocated to RACH is indicated on the BCH. The RACH uses open loop power control.

### 10.2.5 The Synchronisation Channel (SCH)

The SCH is mapped onto the PSCH as described in section The physical synchronisation channel (PSCH).

? [ *Editors Note : In ARIB, SCH is defined as a part of Perch channel.* ]

### 10.2.6 Common Transport Channels for ODMA networks

? [ *Editors Note : In ARIB, there is no ODMA networks and ORACH.* ]

The ORACH is used to transfer short probes or short protocol data units (PDU) between one or more nodes for routing and resource allocation control.

To limit the transmission time of short probe PDUs on the ORACH then this data should be transmitted as one burst on one resource unit (RU). That is, one probe burst should be transmitted on one 625  $\mu$ s timeslot (which as described in section Frame structure would be configured as an ORACH slot).

Since the ORACH is a common control channel used to transfer probes between one or more nodes a common fixed spreading factor should be adopted.

## 10.3 Multiframe structure

? [ *Editors Note : In ARIB, there is no concept of multiframe structure.*  ]

A strong requirement for the multiframe structure comes from the realization of low cost dual mode FDD-TDD terminals and from the GSM compatibility of the UTRA proposal. In this respect the superframe and multiframe structure for FDD and TDD mode have to be compatible and harmonised with GSM.

Thus in the proposed structure a multiframe is composed by 72 frames each of length 10 ms. So the multiframe period is 720 ms.

All frames in the traffic channel multiframe are used to carry both user data and dedicated signalling. The TDD multiframe matches exactly a FDD multiframe ensuring the compatibility of both modes.

## 12History

Document history												
v0.0.1	1999-01-29	Document created based on the documents UMTS (xx.09) V 1.2.0 and ARIB Volume 3 Ver.1.0										
v0.0.2 (v0.1.0)	1999-02-23	Document updated based on the TRGR1 #2(99) 115 which was agreed in the TSG RAN WG1#2 meeting, Yokohama, Feb.23,1999. The usage of ODMA is still under study.										
v0.1.1	1999-02-26	Small changes ( Modification of the editorial errors)										
<p>Editor for 3GPP RAN WG1 physical layer procedures, TDD parts, are:</p> <table> <tbody> <tr> <td>Kazuyuki Miya</td> <td>Keith Mayes</td> </tr> <tr> <td>Matsushita Communication Ind. Co., Ltd.</td> <td>Vodafone Limited</td> </tr> <tr> <td>Tel: +81-468-40-5161</td> <td>Tel: +44-1635-507196</td> </tr> <tr> <td>Fax: +81-468-40-5183</td> <td>Fax: +44-1635-506147</td> </tr> <tr> <td>Email: <b>Error! Bookmark not defined.</b></td> <td>Email: keith.mayes@vf.vodapone.co.uk</td> </tr> </tbody> </table> <p>This document is written in Microsoft Word 97.</p>			Kazuyuki Miya	Keith Mayes	Matsushita Communication Ind. Co., Ltd.	Vodafone Limited	Tel: +81-468-40-5161	Tel: +44-1635-507196	Fax: +81-468-40-5183	Fax: +44-1635-506147	Email: <b>Error! Bookmark not defined.</b>	Email: keith.mayes@vf.vodapone.co.uk
Kazuyuki Miya	Keith Mayes											
Matsushita Communication Ind. Co., Ltd.	Vodafone Limited											
Tel: +81-468-40-5161	Tel: +44-1635-507196											
Fax: +81-468-40-5183	Fax: +44-1635-506147											
Email: <b>Error! Bookmark not defined.</b>	Email: keith.mayes@vf.vodapone.co.uk											