1 Title

2 Paging Concept Paper (Version 4)

3 Source

4 AT&T Wireless

5 Abstract

6 This contribution proposes a concept paper for paging. It uses the following three-part template adopted in
7 GAHW-010241 [12]: identify requirements, recommend concept, and identify impact on specifications.

8 The requirements section uses the model proposed by Alan Cooper in *The Inmates are Running the Asylum – Why
9 High-Tech Products Drive Us Crazy and How to Restore the Sanity*.

10 Questions and comments appear in magenta within angled brackets, e.g., <comment>.

11 Proposals appear in blue, e.g., [proposal](#).

12 This contribution is available in *Acrobat* and *Word* formats. The *Acrobat* format is smaller and has fewer display
13 artifacts.

14 Recommendation

15 Review the proposed changes in § 1.3 (System-based requirements).

16 Review new sections dealing with packet voice: 2.3.2 and 2.3.4.

17 Answer remaining questions.

18 Amend and adopt.

19 History

Document	Date	Description	Editor
G2-010016	25 Jun 2001	First draft.	Lucent
GP-011538	27 Aug 2001	Second draft.	Lucent
GAHW-010273	24 Sep 2001	Third draft.	Lucent
GP-012335	26 Nov 2001	Fourth draft.	AWS

Contents

1.	Requirements	4
1.1	Persona	4
1.2	User-based requirements	4
1.3	System-based requirements	4
1.4	User-based scenarios	5
1.5	System-based scenarios	5
2.	Concept	6
2.1	Incoming circuit voice call – assign dedicated channel	6
2.1.1	<i>RRC-Idle</i>	6
2.1.2	<i>RRC-Cell_Shared</i>	10
2.1.3	<i>RRC-GRA_PCH</i>	12
2.2	Incoming circuit voice call – assign shared channel	15
2.3	Incoming packet voice call – assign dedicated channel	16
2.3.1	<i>RRC-Idle</i>	16
2.3.2	<i>RRC-Cell_Shared</i>	18
2.3.3	<i>RRC-Cell_Dedicated</i>	20
2.3.4	<i>RRC-GRA_PCH</i>	21
2.4	Incoming packet voice call – assign shared channel	24
2.4.1	<i>RRC-Idle</i> , CCCH	24
2.4.2	<i>RRC-Idle</i> , PCCCH	26
2.4.3	<i>RRC-GRA_PCH</i> , CCCH	28
2.4.4	<i>RRC-GRA_PCH</i> , PCCCH	30
2.5	Incoming packet data transfer – assign dedicated channel	33
2.5.1	<i>RRC-Cell_Dedicated</i>	33
2.6	Incoming packet data transfer – assign shared channel	35
2.6.1	<i>RRC-Idle</i> , CCCH	35
2.6.2	<i>RRC-Idle</i> , PCCCH	37
2.6.3	<i>RRC-GRA_PCH</i> , CCCH	39
2.6.4	<i>RRC-GRA_PCH</i> , PCCCH	41
3.	Impact on specifications	44
3.1	Changes to 23.060 (GPRS stage 2)	44
3.2	Changes to 24.008 (CN protocols)	44
3.3	Changes to 25.413 (UTRAN RANAP)	44
3.4	Changes to 44.018 (GERAN RRC)	45
3.5	Changes to 44.060 (GERAN RLC/MAC)	46
3.6	Changes to 45.002 (L1 Multiplexing)	46
4.	References	47
A.	Network-operation modes	48
A.1	GPRS	48
A.2	UMTS	48
A.3	GERAN	48
B.	Paging equations	49
B.1	CCCH	49
B.1.1	Paging blocks per CCCH multiframe (N_m)	49
B.1.2	Paging blocks per CCCH (N_c, M_c)	49
B.1.3	Paging blocks per cell (N_t, M_t)	50
B.1.4	Monitored CCCH	50
B.1.5	Monitored paging block on CCCH	51
B.1.6	Paging multiframe	52
B.1.7	Paging-block index (i)	52
B.2	PCCCH	53
B.2.1	Paging blocks per PCCCH multiframe (N_{pm})	53
B.2.2	Paging blocks per PCCCH (M_{pc})	53
B.2.3	Paging blocks per cell (N_{pt})	53

B.2.4	Monitored PCCCH	53
B.2.5	Monitored paging block on PCCCH.....	54
B.2.6	Paging multiframe	54
B.2.7	Paging-block index (<i>i</i>)	54
B.3	UTRAN.....	55
B.4	DRX values for UTRAN.....	55
C.	States	56
C.1	MM states.....	56
C.2	PMM states	56
C.3	RCC modes	56
C.4	RRC states.....	57

1. Requirements

This document presents paging-related requirements. Based on these requirements, it develops concepts, and from the concepts, assesses the impact on new and existing standards. To focus requirements, it proposes persona, as suggested by Alan Cooper in *The Inmates are Running the Asylum* [1].

1.1 Persona

Lloyd sells specialty automotive parts for Merit, a multinational supplier. His customers include autobody shops, garages, trucking companies, fleet operators, and auto-parts retailers.

Lloyd's key objective is customer service: customers should be able to phone him at any time and get through to Lloyd or his voice mail. From 08:00 to 19:00, seven days a week, Lloyd returns calls within 2 hours.

Lloyd uses two wireless devices:

- A small handset exclusively used for voice.
The handset is on 24 hours a day, 7 days a week. It is Lloyd's key communication device. This handset complies with release-99 specifications for voice terminals. It does not support GPRS.
- A laptop computer for checking stock and processing orders.
This laptop contains a GPRS PC card that allows wireless data access to Merit's servers. The computer is only on when Lloyd is entering new orders or checking status of outstanding orders. Lloyd seldom uses e-mail: he prefers to talk to his customers by phone or meet with them in person.

In the future, Lloyd may want a single device that allows him to perform everything he does now. This document assumes the future is now.

1.2 User-based requirements

To increase battery life, paging shall support discontinuous reception.

Incoming voice calls shall be processed whether or not a data session is active.

Incoming data transfers shall be processed whether or not a voice call is active.

1.3 System-based requirements

~~This section incorporates agreements documented in GP-010975 [14].~~

~~<Each requirement in this section should indicate why the requirement exists.>~~

~~Any mobile station that supports *Iu mode* shall camp on a PCCCH if present. <Why?>~~

~~If a PCCCH is present, the mobile station shall monitor it in *RRC-Idle* and in *RRC-Connected* modes. <Why should the mobile station always monitor PCCCH in *RRC-Connected* mode? If GERAN supports coordinated paging, which it should, a mobile station with an active TBF should only have to monitor PACCH.>~~

Since the PCCCH has more signalling capacity than CCCH, any mobile station that is in *MAC-Idle* state and that supports *Iu mode* shall behave as follows:

- If a PCCCH is present, camp on PCCCH. *Iu-mode* services and *A/Gb-mode* services shall be available.
- Otherwise, camp on CCCH. *A/Gb-mode* services shall be available; *Iu-mode* services shall not.

So the core network and GERAN can establish a signalling link with a mobile station, two types of paging shall be supported: GERAN-initiated and CN-initiated. The mobile station shall be able to determine which network (GERAN or CN) initiated the page.

1 ~~A~~For efficiency, a single PACKET PAGING REQUEST ~~shall~~should be able to contain pages for *A/Gb-mode* and *Iu-*
2 *mode* mobile stations. ~~<Seems needlessly restrictive.>~~

3 ~~A~~For flexibility, a mobile station may respond to a page via a dedicated control channel or via a TBF. ~~<Note, however,~~
4 ~~that~~ ~~if~~ if a mobile station responds to a circuit page using a TBF, and it reselects to a new cell, it may lose the
5 incoming call.>

6 *Iu-mode* paging shall comply with the concepts in this document.

7 *A/Gb-mode* paging shall comply with the concepts in 43.064 [7].

8 1.4 User-based scenarios

9 The following scenarios will be used to develop the paging concepts in § 2:

- 10 • Lloyd receives a voice call.
- 11 • Lloyd receives a voice call while checking the status of a customer's order.
- 12 • Lloyd receives an e-mail order confirmation.
- 13 • Lloyd receives an e-mail order confirmation while engaged in a voice call.

14 1.5 System-based scenarios

15 GERAN shall initiate a page for the following purposes:

- 16 • Locate a mobile station to its serving cell.
- 17 • Activate radio bearers.

18 The CN shall initiate a page for the following purposes:

- 19 • Locate a mobile station to its serving BSS.
- 20 • Activate radio access bearers.

2. Concept

Sequences in this section derive from the requirements and scenarios of § 1. Figures contain the sequence diagrams. A table following each figure describes message events in the sequence, including the values of directly relevant information elements.

<Until 44.018 stabilizes, information elements specified in the tables may be a strange mix of UTRAN and GERAN.>

Within each sequence diagram, the following conventions apply:

- Green arrows indicate unciphered messages.

- Red arrows indicate ciphered messages.

<Ciphered messages need to be confirmed when the concept paper on ciphering and integrity protection is ready.>

- Dashed arrows indicate optional messages.

- Heavy vertical lines indicate a stimulus-response relationship between messages.

Unless stated otherwise, the following conditions apply for each sequence:

- The CN and GERAN operate in *GERAN Network Operation Mode II*: SGSN and MSC are not connected via a *Gs* interface; circuit pages arrive over the *Iu-cs* interface. See § A for a description of network-operation modes for GPRS, UMTS, and GERAN.
- The CCCH supports discontinuous reception according to the formulas described in § B.1. A mobile station operating in *Iu mode* will behave as a GPRS-attached mobile station described in § B.1.
- The PCCCH supports discontinuous reception according to the formulas described in § B.2.
- MM, PMM, and RRC have the states described in § C.

2.1 Incoming circuit voice call – assign dedicated channel

In this section, a circuit voice call will arrive over the *Iu-cs* interface. The GERAN RRC assigns an SDCCH (Stand-Alone Dedicated Control Channel) for the mobile station to respond to the page.

2.1.1 *RRC-Idle*

This sequence corresponds to the following user-based scenario:

- Lloyd receives a voice call.

Figure 1 shows the paging-related portion of an incoming circuit voice call under the following conditions:

- RRC is in *RRC-Idle* mode.
- MM is in *MM-Idle* state.
- PMM is in *PMM-Idle* state.
- MAC is in *MAC-Idle* state; the mobile station monitors a CCCH or a PCCCH.

Figure 1: Incoming circuit voice call – RRC-Idle, assign dedicated channel

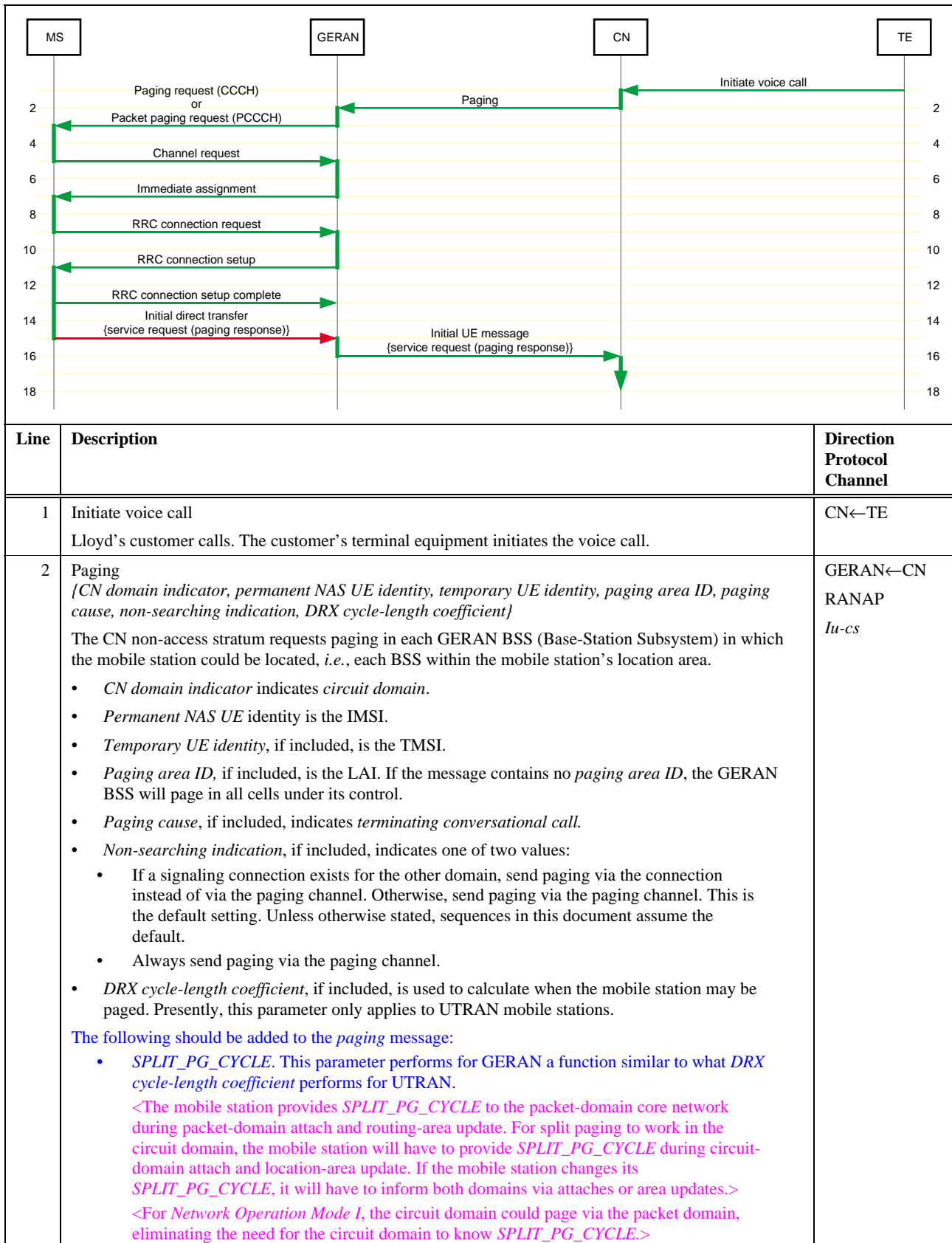

3a	<p>Paging request {page mode, channel needed, mobile identity, P1 rest octets}</p> <p>Since the GERAN RRC is in <i>RCC-Idle</i> mode for this IMSI, it does not know where the mobile station is. It therefore sends a CN-initiated <i>paging request</i> on all paging channels the mobile station could monitor. Upon receipt of the <i>paging request</i>, the MS RRC informs its non-access stratum that the core network has paged it. The MS NAS responds to the page.</p> <ul style="list-style-type: none"> • <i>Channel needed</i> indicates SDCCH. It could also indicate TCH. • <i>Mobile identity</i> is the mobile station's IMSI, or if available, TMSI. • <i>P1 rest octets</i> indicates <i>paging procedure for RR connection establishment</i>. RRC only includes this information if <i>mobile identity</i> is IMSI. If mobile identity is TMSI, <i>paging procedure for RR connection establishment</i> is assumed. <p>The following should be added to the <i>paging request</i>:</p> <ul style="list-style-type: none"> • An implicit indication of which network element initiated the page: CN or GERAN. The presence of <i>paging cause</i> indicates a CN-initiated page; the absence of <i>paging cause</i> indicates a GERAN-initiated page. This requires that GERAN indicate a <i>paging cause of cause unknown</i> if the CN does not provide a <i>paging cause</i> in the RANAP <i>paging</i> message. • An indication of which core network initiated the page: circuit-domain or packet-domain. If paging with IMSI, include this element. If paging with P-TMSI or TMSI, omit the element since the identity implicitly indicates the network initiating the page. • <i>Paging cause</i> from the RANAP <i>paging</i> message. 	MS←GERAN RRC CCCH (PCH)
3b	<p>Packet paging request {page mode, persistence level, NLN, page info (TBF or dedicated, mobile identity, channel needed)}</p> <p>Since the GERAN RRC is in <i>Idle</i> mode for this IMSI, it does not know where the mobile station is. It therefore has MAC send a CN-initiated <i>packet paging request</i> on all paging channels the mobile station could monitor. Upon receipt of the <i>packet paging request</i>, the MS MAC informs its non-access stratum that the core network has paged it. The MS NAS responds to the page.</p> <ul style="list-style-type: none"> • <i>TBF or dedicated</i> indicates establishment of a dedicated connection. • <i>Mobile identity</i> is the mobile station's IMSI, or if available, TMSI. • <i>Channel needed</i> indicates SDCCH. It could also indicate TCH. <p>The following should be added to the <i>packet paging request</i>:</p> <ul style="list-style-type: none"> • An implicit indication of which network element initiated the page: CN or GERAN. The presence of <i>paging cause</i> indicates a CN-initiated page; the absence of <i>paging cause</i> indicates a GERAN-initiated page. This requires that GERAN indicate a <i>paging cause of cause unknown</i> if the CN does not provide a <i>paging cause</i> in the RANAP <i>paging</i> message. • An indication of which core network initiated the page: circuit-domain or packet-domain. If paging with IMSI, include this element. If paging with P-TMSI or TMSI, omit the element since the identity implicitly indicates the network initiating the page. • <i>Paging cause</i> from the RANAP <i>paging</i> message. 	MS←GERAN MAC PCCCH (PPCH)
5	<p>Channel request {establishment cause, random reference}</p> <p>The MS RRC requests a channel to respond to the page.</p> <ul style="list-style-type: none"> • <i>Establishment cause</i> indicates <i>answer to paging</i>. 	MS→GERAN RRC CCCH (RACH)
7	<p>Immediate assignment {page mode, dedicated mode or TBF, channel description, request reference, timing advance, mobile allocation, starting time, IA rest octets (frequency parameters before time)}</p> <p>The GERAN RRC assigns an SDCCH.</p> <ul style="list-style-type: none"> • <i>Dedicated mode or TBF</i> indicates <i>dedicated mode</i>. • <i>Request reference</i> comprises the contents of the <i>channel request</i> message and the frame number in which the <i>channel request</i> message was received. It is used to address the mobile station. • <i>Channel description</i> specifies parameters for the SDCCH. 	MS←GERAN RRC CCCH (AGCH)

9	<p>RRC connection request <i>{initial UE identity, establishment cause}</i></p> <p>Since the MS RRC is in <i>RCC-Idle</i> mode, it needs to establish an RRC connection with its GERAN peer. It therefore sends an <i>RRC connection request</i>.</p> <ul style="list-style-type: none"> • <i>Initial UE identity</i> indicates IMSI, or if available, TMSI. • <i>Establishment cause</i> indicates <i>terminating conversational call</i>. <p><Do we want to define an RB0 to carry the <i>RRC connection request</i> and <i>RRC connection setup</i>? Such a radio bearer would have an RLC instance, e.g., <i>acknowledged mode</i>.></p>	MS→GERAN RRC SDCCH
11	<p>RRC connection setup <i>{initial UE identity, RRC transaction identifier, new U-RNTI, RRC state indicator, UTRAN DRX cycle-length coefficient, signalling RB information setup list}</i></p> <p>The GERAN RRC provides the information needed to support the RRC connection.</p> <ul style="list-style-type: none"> • <i>Initial UE identity</i> indicates IMSI, or if available, TMSI. • <i>RRC transaction identifier</i> identifies the transaction. Subsequent messages in the transaction use this identifier. • <i>New U-RNTI</i> (in GERAN, G-RNTI) provides the new GERAN <i>Radio Network Temporary Identifier</i>. The identifier applies for the duration of the RRC connection. • <i>RRC state indicator</i> specifies that the mobile station enter <i>RRC Cell Dedicated</i> state. • <i>UTRAN DRX cycle-length coefficient</i> is used to calculate when the mobile station may be paged while connected to this UTRAN. GERAN will not use this capability, i.e., DRX cycle length will not change when the mobile station moves from <i>RRC Idle</i> mode to <i>RRC connected</i> mode. <This may be a problem. How does GERAN know what DRX parameters to use for a GERAN-initiated page if the CN has never passed these parameters to GERAN? See § figure 10 line 3.> • <i>Signalling RB information setup list</i> configures the four signaling radio bearers. 	MS←GERAN RRC SDCCH
13	<p>RRC connection setup complete <i>{RRC transaction identifier, START list, UE radio access capability}</i></p> <p>The MS RRC confirms setup of the RRC connection. RRC enters <i>RRC-Cell_Dedicated</i> state. The following radio bearers now exist: RB1 (unacknowledged access-stratum signalling), RB2 (acknowledged access-stratum signalling), RB3 (acknowledged high-priority non-access-stratum signalling), and RB4 (acknowledged low-priority non-access-stratum signalling).</p> <ul style="list-style-type: none"> • <i>RRC transaction identifier</i> is the value sent in the <i>RRC connection setup</i> message. • <i>START list</i> identifies the CN domain (circuit) and initializes the 20 most-significant bits of the hyperframe numbers. <Is this initialization the first point where ciphering and integrity protection can operate?> • <i>UE radio-access capability</i> indicates the mobile station's capabilities with respect to the <i>Um</i> interface, e.g., PDCP capability, RLC capability, RF capability. 	MS→GERAN RRC RB2 (SDCCH)
15	<p>Initial direct transfer <i>{CN domain identity, intra-domain NAS node selector, NAS message}</i></p> <p>The MS RRC initiates a signaling connection to the circuit CN and forwards the MS NAS paging response.</p> <ul style="list-style-type: none"> • <i>CN domain identity</i> indicates <i>circuit domain</i>. • <i>Intra-domain NAS node selector</i> indicates the NAS node to which the MS wants to establish a connection. • <i>NAS message</i> contains the <i>service request</i> message indicating <i>paging response</i>. 	MS→GERAN RRC RB3 (SDCCH)
16	<p>Initial UE message <i>{CN domain indicator, LAI, SAI, NAS-PDU, Iu signalling-connection identifier, Global RNC-ID}</i></p> <p>GERAN forwards the page response to the CN.</p> <ul style="list-style-type: none"> • <i>CN domain indicator</i> indicates <i>circuit domain</i>. • <i>LAI</i> indicates the location area in which the RRC connection exists. • <i>SAI</i> indicates the service area where the mobile station is consuming resources. • <i>Iu signalling-connection identifier</i> is assigned by GERAN and stored by the CN for the duration of the <i>Iu</i> connection. • <i>Global RNC-ID</i> uniquely identifies the GERAN BSS. 	GERAN→CN RANAP <i>Iu-cs</i>

1 2.1.2 *RRC-Cell_Shared*

2 This sequence corresponds to the following user-based scenario:

- 3 • Lloyd receives a voice call while checking the status of a customer's order.

4 Figure 2 shows the paging-related portion of an incoming circuit voice call under the following conditions:

- 5 • RRC is in *RRC-Cell_Shared* state.
- 6 • MM is in *MM-Idle* state.
- 7 • PMM is in *PMM-Connected* state.
- 8 • MAC is in *MAC-Idle* state or *MAC-Shared* state.
9 The mobile station monitors a CCCH or a PCCCH (*i.e.*, it is in *MAC-Idle* state; it does not have a TBF), or it
10 monitors a PACCH (*i.e.*, it is in *MAC-Shared* state; it has one or more TBFs).

11 <GP-011545 [Siemens], *CS Paging in RRC Cell_Shared*, is being considered. If the contribution is adopted, this section
12 will change.>

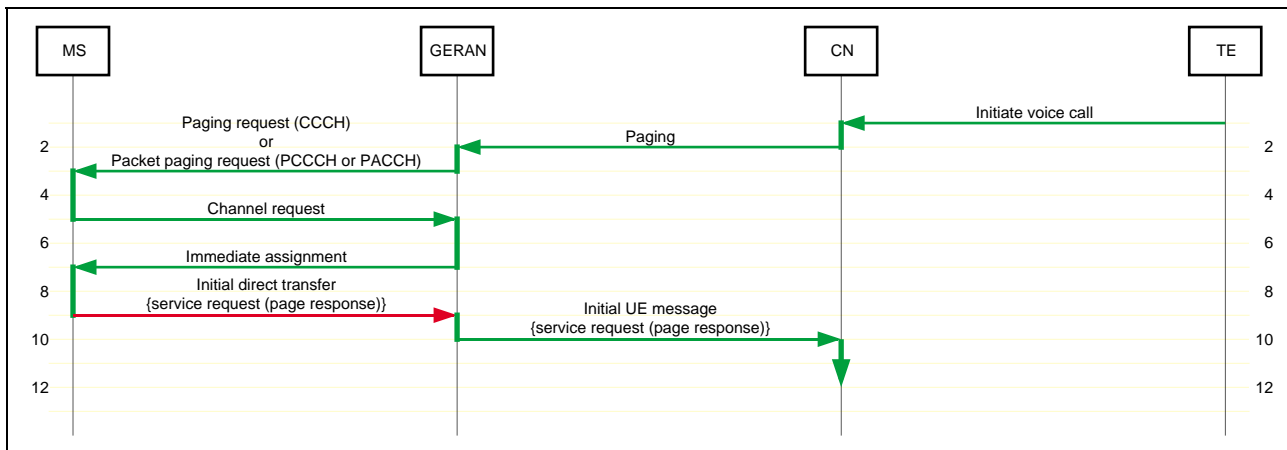
Figure 2: Incoming circuit voice call – *RRC-Cell_Shared*, assign dedicated channel

Line	Description	Direction Protocol Channel
1	Initiate voice call Lloyd's customer calls while Lloyd is checking the status of a customer order. The customer's terminal equipment initiates the voice call.	CN←TE
2	Paging {CN domain indicator, permanent NAS UE identity, temporary UE identity, paging area ID, paging cause, non-searching indication, DRX cycle-length coefficient} Same as § 2.1.1 line 2 with the following exceptions: <ul style="list-style-type: none"> Paging area ID, if included, can be ignored. GERAN knows the mobile station's location. 	GERAN←CN RANAP <i>Iu-cs</i>
3a	Paging request {page mode, channel needed, mobile identity, P1 rest octets} Since the GERAN RRC is in <i>RRC-Cell_Shared</i> state for this IMSI, it knows where the mobile station is. It therefore sends a CN-initiated <i>paging request</i> on the paging channel the mobile station is monitoring. Upon receipt of the <i>paging request</i> , the MS RRC informs its non-access stratum that the core network has paged it. The MS NAS responds to the page. <ul style="list-style-type: none"> <i>Channel needed</i> indicates SDCCH. It could also indicate TCH. <i>Mobile identity</i> is the G-RNTI. <i>P1 rest octets</i> indicates <i>paging procedure for RR connection establishment</i>. <Presently, RRC only includes this information if <i>mobile identity</i> is IMSI.> In addition to § 2.1.1, the following should be added to the <i>paging request</i> : <ul style="list-style-type: none"> G-RNTI as a <i>mobile identity</i>. <i>P1 rest octets</i> applies when paging with G-RNTI. This applies for <i>paging request type 1</i>. <i>P2 rest octets</i> should also be updated for <i>paging request type 2</i>. 	MS←GERAN RRC CCCH (PCH)
3b	Packet paging request {page mode, persistence level, NLN, page info (TBF or dedicated, mobile identity, channel needed)} Since the GERAN RRC is in <i>RRC-Cell_Shared</i> state for this IMSI, it knows where the mobile station is. It therefore has MAC send a CN-initiated <i>packet paging request</i> on the channel the mobile station is monitoring. Upon receipt of the <i>packet paging request</i> , the MS MAC informs its non-access stratum that the core network has paged it. The MS NAS responds to the page. <ul style="list-style-type: none"> <i>TBF or dedicated</i> indicates establishment of a dedicated connection. <i>Mobile identity</i> is the G-RNTI. <i>Channel needed</i> indicates SDCCH. It could also indicate TCH. In addition to § 2.1.1, the following should be added to the <i>packet paging request</i> : <ul style="list-style-type: none"> G-RNTI as a <i>mobile identity</i>. 	MS←GERAN MAC PCCCH (PPCH) or PACCH
5	Channel request {establishment cause, random reference} Same as § 2.1.1 line 5.	MS→GERAN RRC CCCH (RACH)

7	<p>Immediate assignment <i>{page mode, dedicated mode or TBF, channel description, request reference, timing advance, mobile allocation, starting time, IA rest octets (frequency parameters before time)}</i></p> <p>Same as § 2.1.1 line 7 except for the following:</p> <ul style="list-style-type: none"> RRC enters <i>RRC-Cell_Dedicated</i> state. 	<p>MS←GERAN RRC CCCH (AGCH)</p>
	<p>At this point, 25.331 § 8.1.2.3 specifies that the mobile station perform a cell update. Since GERAN knows exactly where the mobile station is and the signaling radio bearers are established, it doesn't need a cell update.</p> <p>One reason for a cell update would be to explicitly signal the RRC to enter <i>RRC-Cell_Dedicated</i> state.</p>	
9	<p>Initial direct transfer <i>{CN domain identity, intra-domain NAS node selector, NAS message}</i></p> <p>Same as § 2.1.1 line 15.</p>	<p>MS→GERAN RRC RB3 (SDCCH)</p>
10	<p>Initial UE message <i>{CN domain indicator, LAI, SAI, NAS-PDU, Iu signalling-connection identifier, Global RNC-ID}</i></p> <p>Same as § 2.1.1 line 16.</p>	<p>GERAN→CN RANAP Iu-cs</p>

1

2.1.3 RRC-GRA_PCH

This sequence corresponds to the following user-based scenario:

- Lloyd receives a voice call.

Figure 3 shows the paging-related portion of an incoming circuit voice call under the following conditions:

- RRC is in *RRC-GRA_PCH* state.
- MM is in *MM-Idle* state.
- PMM is in *PMM-Connected* state.
- MAC is in *MAC-Idle* state; the mobile station monitors a CCCH or a PCCCH.

<This section has unresolved problems related to the Iur-g interface. G2-010075 [Nortel] and G2-010089 [Siemens] contain proposals. Should the mobile station perform a cell update?>

11

Figure 3: Incoming circuit voice call – RRC-GRA_PCH, assign dedicated channel

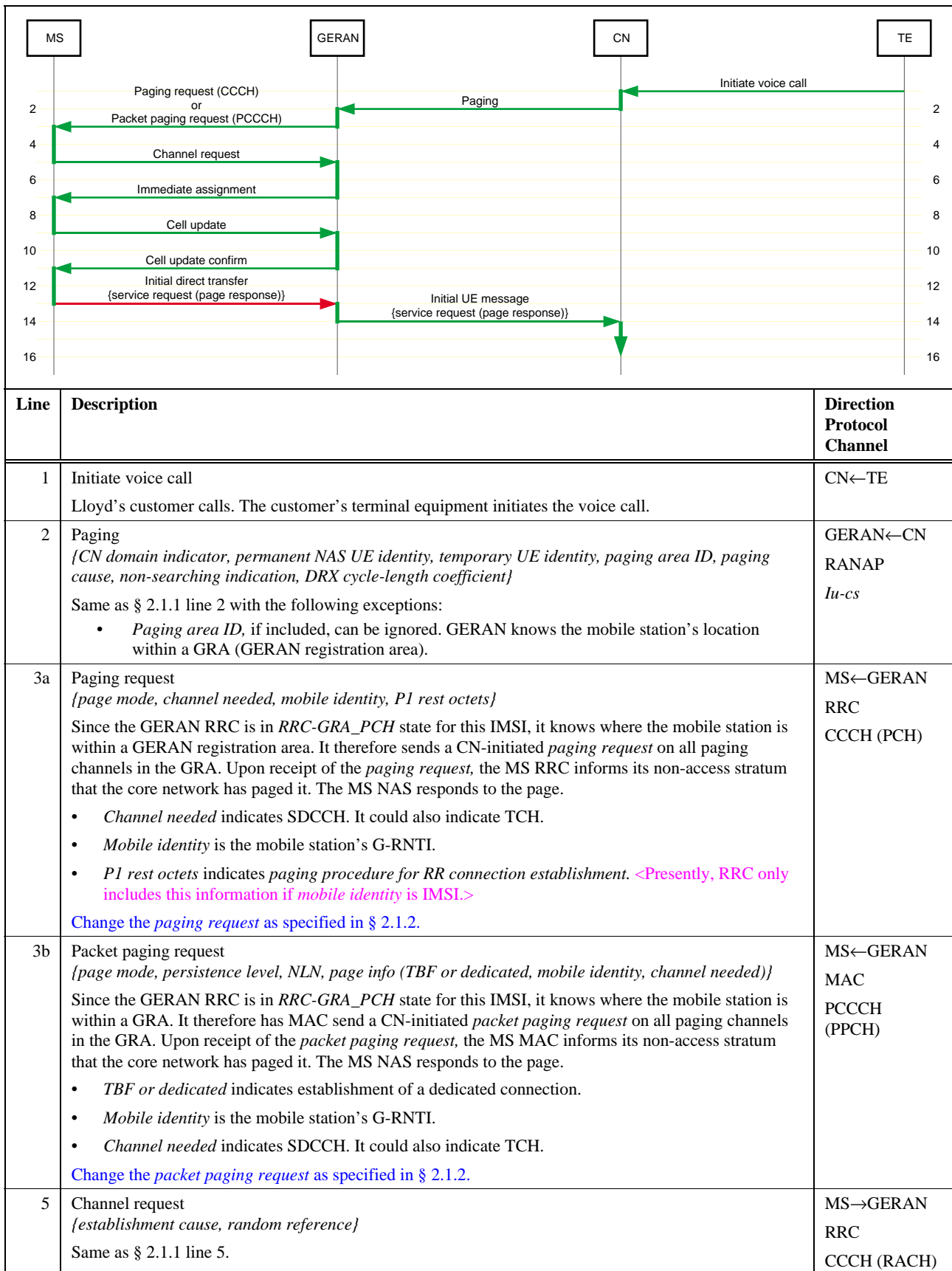

7	<p>Immediate assignment <i>{page mode, dedicated mode or TBF, channel description, request reference, timing advance, mobile allocation, starting time, IA rest octets (frequency parameters before time)}</i></p> <p>Same as § 2.1.1 line 7.</p>	<p>MS←GERAN RRC CCCH (AGCH)</p>
9	<p>Cell update <i>{U-RNTI, START list, AM_RLC error indication (RB2 or RB3), AM_RLC error indication (RB4 and upwards), cell-update cause, RB-timer indicator}</i></p> <p>The MS RRC updates its cell-location information in the GERAN RRC by sending a <i>cell update</i>. The GERAN RRC now knows the mobile station's location to the cell level instead of the GRA level.</p> <ul style="list-style-type: none"> • <i>U-RNTI</i> (in GERAN, G-RNTI) identifies the mobile station. • <i>START list</i> identifies the CN domain (circuit) and initializes the 20 most-significant bits of the hyperframe numbers. • <i>AM_RLC error indication (RB2 or RB3)</i> indicates <i>no error</i>. • <i>AM_RLC error indication (RB4 and upwards)</i> indicates <i>no error</i>. • <i>Cell-update cause</i> indicates <i>paging response</i>. • <i>RB-timer indicator</i> indicates if T314 or T315 have expired. These timers relate to radio-link failure. 	<p>MS→GERAN RRC RB1 (SDCCH)</p>
11	<p>Cell update confirm <i>{RRC transaction identifier, activation time, RRC state indicator, UTRAN DRX cycle length coefficient, RLC re-establish indicator (RB2 and RB3), RLC re-establish indicator (RB4 and upwards), <channel and radio-resource configuration information elements (reams of information elements of dubious usefulness)>}</i></p> <p>The GERAN RRC confirms that it has updated the cell-location information.</p> <ul style="list-style-type: none"> • <i>RRC transaction identifier</i> identifies the transaction. Subsequent messages in the transaction use this identifier. • <i>Activation time</i> indicates when changes signaled by the message take effect. If not included, the default is <i>now</i>. • <i>RRC state indicator</i> specifies that the mobile station enter <i>RRC-Cell_Dedicated</i> state. • <i>UTRAN DRX cycle-length coefficient</i> is used to calculate when the mobile station may be paged while connected to this UTRAN. GERAN will not use this capability, <i>i.e.</i>, DRX cycle length will not change when the mobile station moves from <i>RRC Idle</i> mode to <i>RRC connected</i> mode. • <i>RLC re-establish indicator (RB2 and RB3)</i> indicates that RB2 and RB3 should be re-established. • <i>RLC re-establish indicator (RB4 and upwards)</i> indicates that RB4 and higher radio bearers should be re-established. 	<p>MS←GERAN RRC RB1 (SDCCH)</p>
13	<p>Initial direct transfer <i>{CN domain identity, intra-domain NAS node selector, NAS message}</i></p> <p>The MS RRC initiates a signaling connection to the circuit CN and forwards the MS NAS paging response.</p> <p>If a connection to the circuit CN already exists (MM is in <i>MM-connected</i> state), the MS RRC sends a <i>direct transfer</i> message.</p> <ul style="list-style-type: none"> • <i>CN domain identity</i> indicates <i>circuit domain</i>. • <i>Intra-domain NAS node selector</i> indicates the NAS node to which the MS wants to establish a connection. • <i>NAS message</i> contains the <i>service request</i> message indicating <i>paging response</i>. 	<p>MS→GERAN RRC RB3 (SDCCH)</p>
14	<p>Initial UE message <i>{CN domain indicator, LAI, SAI, NAS-PDU, Iu signalling-connection identifier, Global RNC-ID}</i></p> <p>GERAN forwards the page response to the CN.</p> <p>If a connection to the circuit CN already exists (MM is in <i>MM-connected</i> state), the MS RRC will send a <i>direct transfer</i> message.</p> <ul style="list-style-type: none"> • <i>CN domain indicator</i> indicates <i>circuit domain</i>. • <i>LAI</i> indicates the location area in which the RRC connection exists. • <i>SAI</i> indicates the service area where the mobile station is consuming resources. • <i>Iu signalling-connection identifier</i> is assigned by GERAN and stored by the CN for the duration of the <i>Iu</i> connection. • <i>Global RNC-ID</i> uniquely identifies the GERAN BSS. 	<p>GERAN→CN RANAP <i>Iu-cs</i></p>

1 2.2 Incoming circuit voice call – assign shared channel

2 In this section, a circuit voice call will arrive over the *Iu-cs* interface. The GERAN RRC assigns a shared channel for
3 the mobile station to respond to the page.

4 Sequences in this section are deprecated for the following reasons:

- 5 • If the mobile station reselects a new cell, the incoming voice call will be lost. <Network control of cell
6 reselection may mitigate this problem.>

7 Since the sequences are deprecated, they have been abandoned. GP-011538 contains the abandoned sequences.

1 2.3 Incoming packet voice call – assign dedicated channel

2 In this section, a packet voice call will arrive over the *Iu-ps* interface. The GERAN RRC assigns an SDCCH (Stand-
3 Alone Dedicated Control Channel) for the mobile station to respond to the page.

4 2.3.1 *RRC-Idle*

5 This sequence corresponds to the following user-based scenario:

- 6 • Lloyd receives a voice call.

7 Figure 4 shows the paging-related portion of an incoming packet voice call under the following conditions:

- 8 • RRC is in *RRC-Idle* mode.
- 9 • MM is in *MM-Idle* state.
- 10 • PMM is in *PMM-Idle* state.
- 11 • MAC is in *MAC-Idle* state; the mobile station monitors a CCCH or a PCCCH.

Figure 4: Incoming packet voice call – RRC-Idle, assign dedicated channel

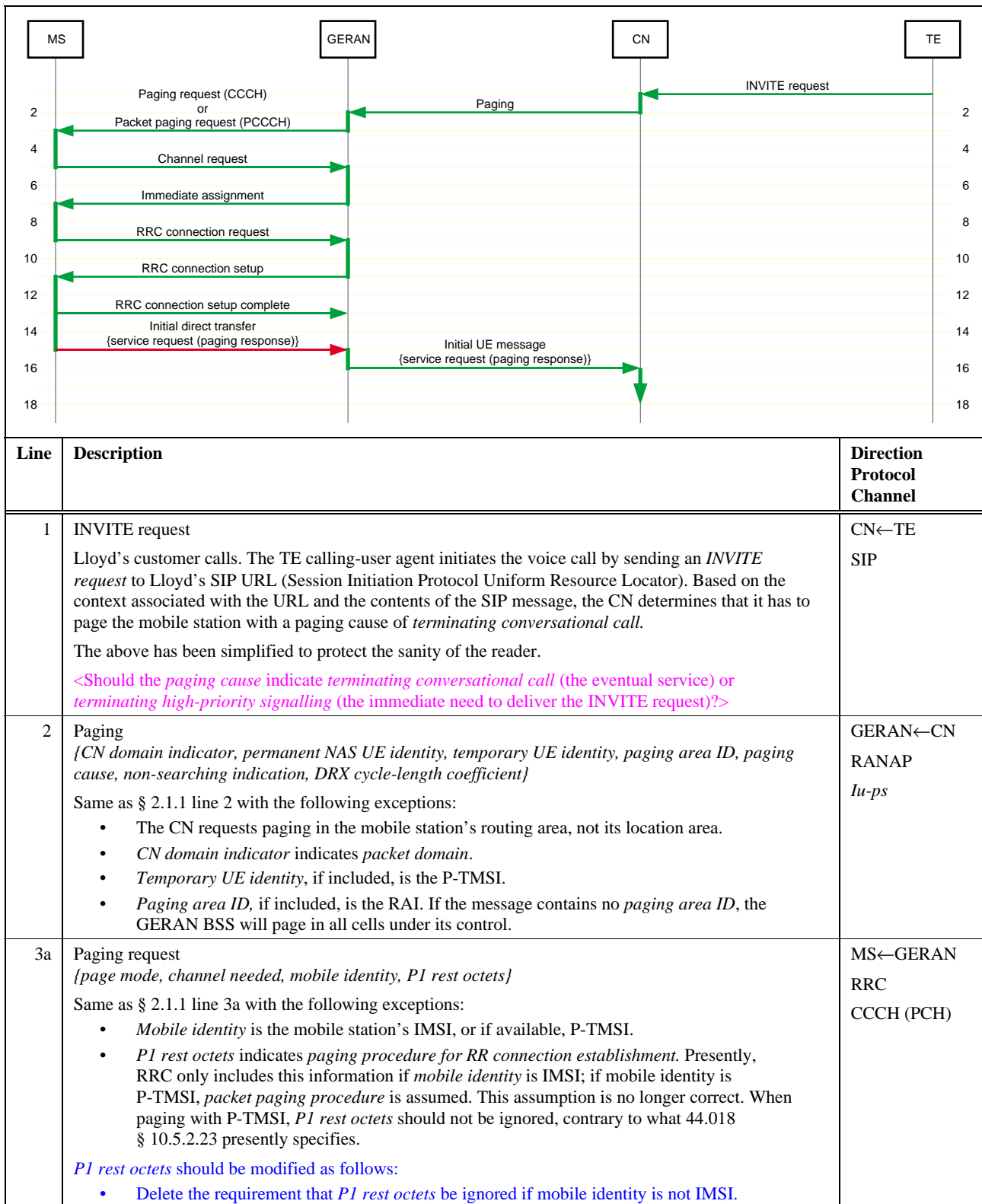

3b	<p>Packet paging request {page mode, persistence level, NLN, page info (TBF or dedicated, mobile identity, channel needed)}</p> <p>Same as § 2.1.1 line 3b with the following exceptions:</p> <ul style="list-style-type: none"> • <i>Mobile identity</i> is the mobile station's IMSI, or if available, P-TMSI. • <i>TBF or dedicated</i> must indicate <i>page request for RR connection establishment</i>, even though P-TMSI may be used. 44.060 § 11.2.10 does not presently allow this. <p>The following should be changed in the <i>packet paging request</i>:</p> <ul style="list-style-type: none"> • Support paging with P-TSMI for RR connection establishment. 	<p>MS←GERAN MAC PCCCH (PPCH)</p>
5	<p>Channel request {establishment cause, random reference}</p> <p>Same as § 2.1.1 line 5.</p>	<p>MS→GERAN RRC CCCH (RACH)</p>
7	<p>Immediate assignment {page mode, dedicated mode or TBF, channel description, request reference, timing advance, mobile allocation, starting time, IA rest octets (frequency parameters before time)}</p> <p>Same as § 2.1.1 line 7.</p>	<p>MS←GERAN RRC CCCH (AGCH)</p>
9	<p>RRC connection request {initial UE identity, establishment cause}</p> <p>Same as § 2.1.1 line 9 with the following exceptions:</p> <ul style="list-style-type: none"> • <i>Initial UE identity</i> indicates IMSI, or if available, P-TMSI. 	<p>MS→GERAN RRC SDCCH</p>
11	<p>RRC connection setup {initial UE identity, RRC transaction identifier, new U-RNTI, RRC state indicator, UTRAN DRX cycle-length coefficient, signalling RB information setup list}</p> <p>Same as § 2.1.1 line 11 with the following exceptions:</p> <ul style="list-style-type: none"> • <i>Initial UE identity</i> indicates IMSI, or if available, P-TMSI. 	<p>MS←GERAN RRC SDCCH</p>
13	<p>RRC connection setup complete {RRC transaction identifier, START list, UE radio access capability}</p> <p>Same as § 2.1.1 line 13.</p>	<p>MS→GERAN RRC RB2 (SDCCH)</p>
15	<p>Initial direct transfer {CN domain identity, intra-domain NAS node selector, NAS message}</p> <p>Same as § 2.1.1 line 15 with the following exceptions:</p> <ul style="list-style-type: none"> • <i>CN domain identity</i> indicates <i>packet domain</i> 	<p>MS→GERAN RRC RB3 (SDCCH)</p>
16	<p>Initial UE message {CN domain indicator, LAI, RAC, SAI, NAS-PDU, Iu signalling-connection identifier, Global RNC-ID}</p> <p>Same as § 2.1.1 line 16 with the following exceptions:</p> <ul style="list-style-type: none"> • <i>CN domain indicator</i> indicates <i>packet domain</i>. • <i>RAC</i> indicates the routing area in which the RRC connection exists. 	<p>GERAN→CN RANAP <i>Iu-ps</i></p>

1

2.3.2 RRC-Cell_Shared

This sequence corresponds to the following user-based scenario:

- Lloyd receives a voice call while checking the status of a customer's order.

Figure 5 shows an incoming packet voice call under the following conditions:

- RRC is in *RRC-Cell_Shared* state.
- MM is in *MM-Idle* state.
- PMM is in *PMM-Connected* state.
- MAC is in *MAC-Idle* state or *MAC-Shared* state.

If MAC is in *MAC-Shared* state, this is not a paging sequence, but for completeness, it has been provided anyway. To reduce signalling delays, this sequence assumes that a PDP context exists for SIP and that a radio-access bearer has been established for this context.

12

Figure 5: Incoming packet voice call – RRC-Shared, assign dedicated channel

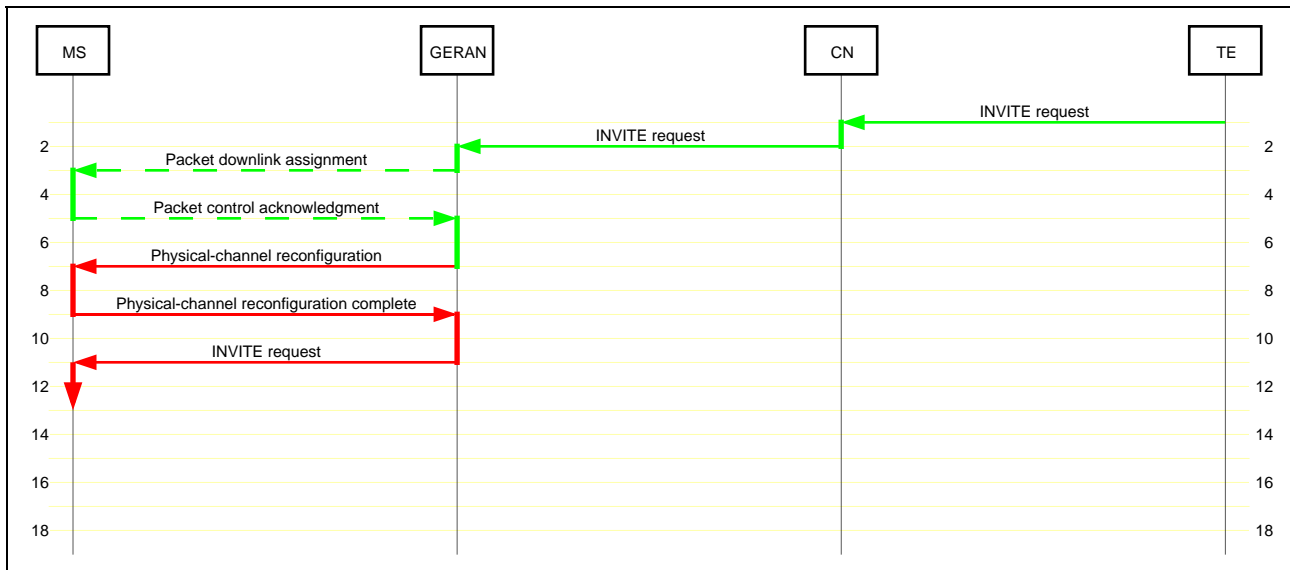

Line	Description	Direction Protocol Channel
1	INVITE request Lloyd's customer calls. The TE calling-user agent initiates the voice call by sending an <i>INVITE request</i> to Lloyd's SIP URL (Session Initiation Protocol Uniform Resource Locator). Based on the context associated with the URL and the contents of the SIP message, the CN determines that it can reach the mobile station via a radio access bearer (RAB).	CN←TE SIP
2	INVITE request Since the CN still has an <i>Iu</i> connection for this mobile station, it sends the INVITE request to GERAN via the RAB established for this purpose: RABx. The GERAN RRC determines it has no physical-layer resources assigned to the radio bearer that serves RABx.	GERAN←CN GTP RABx (<i>Iu-ps</i>)
3	Packet downlink assignment (optional) <i>{page mode, persistence level, global TFI, MAC mode, RLC mode, control ack, timeslot allocation, packet timing advance, P0, BTS pwr-control mode, PR mode, frequency parameters, downlink TFI assignment, power-control parameters, TBF starting time, measurement mapping}</i> If the GERAN RRC determines it has no physical-layer resources assigned to signalling radio bearers, it instructs the GERAN MAC to establish a downlink TBF. In <i>MAC-Idle</i> state, MAC sends the message over PCCCH. In <i>MAC-Shared</i> state, MAC sends the message over PACCH.	MS←GERAN MAC PCCCH or PACCH
5	Packet control acknowledgment (optional) <i>{ctrl_ack}</i> If MAC was in <i>MAC-Idle</i> state when it received the <i>packet downlink assignment</i> and if timing alignment needs to be performed, it returns a <i>packet control acknowledgment</i> .	MS→GERAN MAC PACCH
7	Physical-channel reconfiguration <i>{<parameters to be determined>}</i> The GERAN RRC assigns a dedicated physical subchannel, in addition to the existing shared physical subchannel. The dedicated channel will carry RBx, the radio bearer for RABx. <i>Add a physical-channel reconfiguration message based on the 25.331 message of the same name.</i>	MS←GERAN RRC RB2 (<?>)
9	Physical-channel reconfiguration complete <i>{<parameters to be determined>}</i> The MS RRC confirms reconfiguration of the physical layer. <i>Add a physical-channel reconfiguration complete message based on the 25.331 message of the same name.</i>	MS→GERAN RRC RB2 (<?>)
11	INVITE request GERAN delivers the INVITE request to the mobile station.	MS←GERAN PDCP RBx (PDTCH)

2.3.3 RRC-Cell_Dedicated

This sequence corresponds to the following user-based scenario:

- Lloyd receives a voice call while using a circuit data connection to check the status of a customer's order.

Figure 12 shows the paging-related portion of an incoming packet voice call under the following conditions:

- RRC is in *RRC-Cell_Dedicated* state.
- MM is in *MM-Connected* state.
- PMM is in *PMM-Idle* state.
- MAC is in *MAC-Dedicated* state; the mobile station is on a TCH.

Figure 6: Incoming packet voice call – RRC-Cell_Dedicated, assign dedicated channel

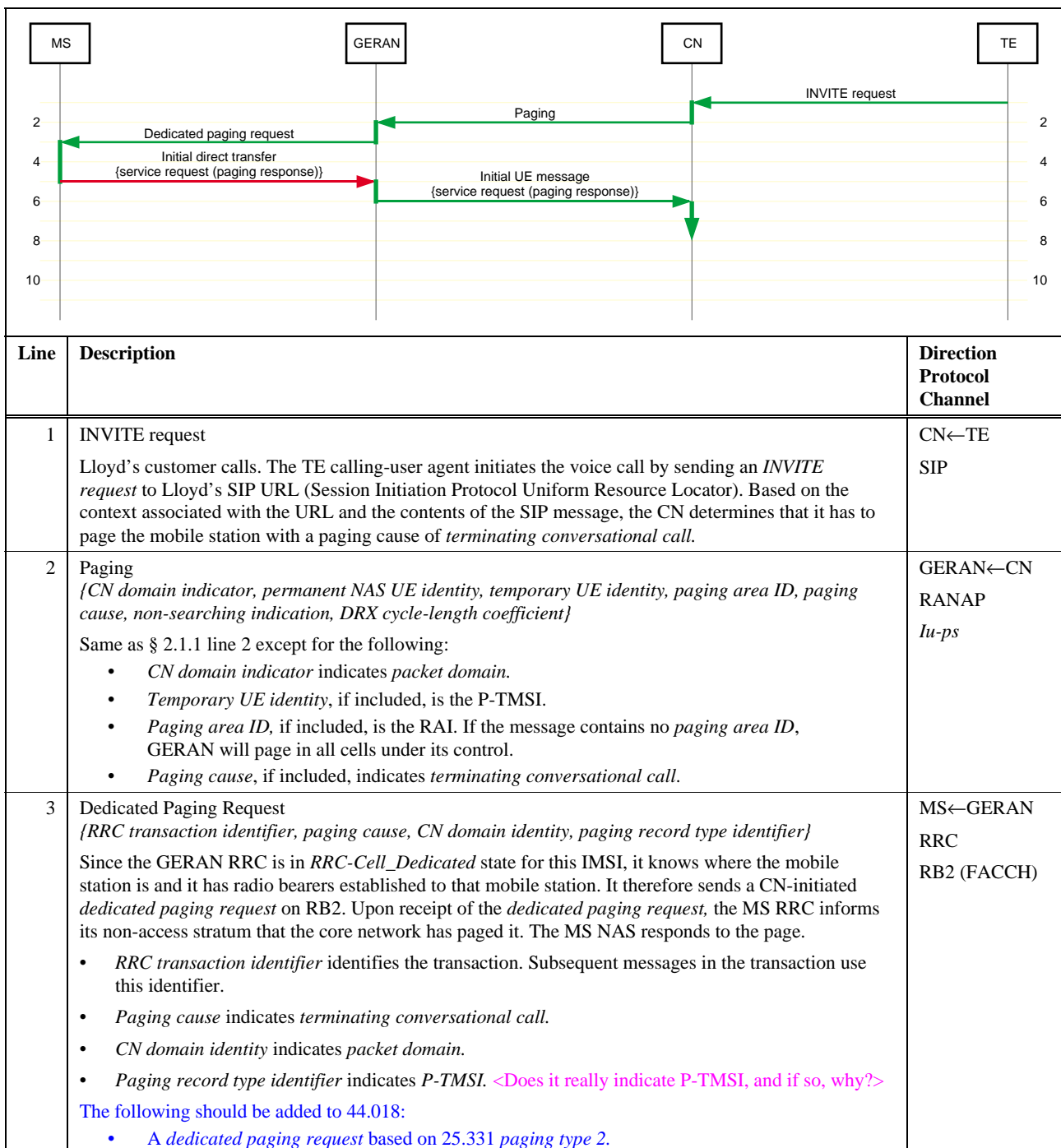

5	<p>Initial direct transfer <i>{CN domain identity, intra-domain NAS node selector, NAS message}</i></p> <p>The MS RRC initiates a signaling connection to the packet CN and forwards the MS NAS paging response.</p> <ul style="list-style-type: none"> • <i>CN domain identity</i> indicates <i>packet domain</i>. • <i>Intra-domain NAS node selector</i> indicates the NAS node to which the MS wants to establish a connection. • <i>NAS message</i> contains the <i>service request</i> message indicating <i>paging response</i>. 	MS→GERAN RRC RB3 (FACCH)
6	<p>Initial UE message <i>{CN domain indicator, LAI, RAC, SAI, NAS-PDU, Iu signalling-connection identifier, Global RNC-ID}</i></p> <p>Same as § 2.1.1 line 16 except for the following:</p> <ul style="list-style-type: none"> • <i>CN domain indicator</i> indicates <i>packet domain</i>. • <i>RAC</i> indicates the routing area in which the RRC connection exists. 	GERAN→CN RANAP <i>Iu-ps</i>

1

2 2.3.4 RRC-GRA_PCH

3 This sequence corresponds to the following user-based scenario:

- 4
- Lloyd receives a voice call.

5 Figure 7 shows the paging-related portion of an incoming packet voice call under the following conditions:

- 6
- RRC is in *RRC-GRA_PCH* state.
 - 7
 - MM is in *MM-Idle* state.
 - 8
 - PMM is in *PMM-Connected* state.
 - 9
 - MAC is in *MAC-Idle* state; the mobile station monitors a CCCH or a PCCCH.

Figure 7: Incoming packet voice call – RRC-GRA_PCH, assign dedicated channel

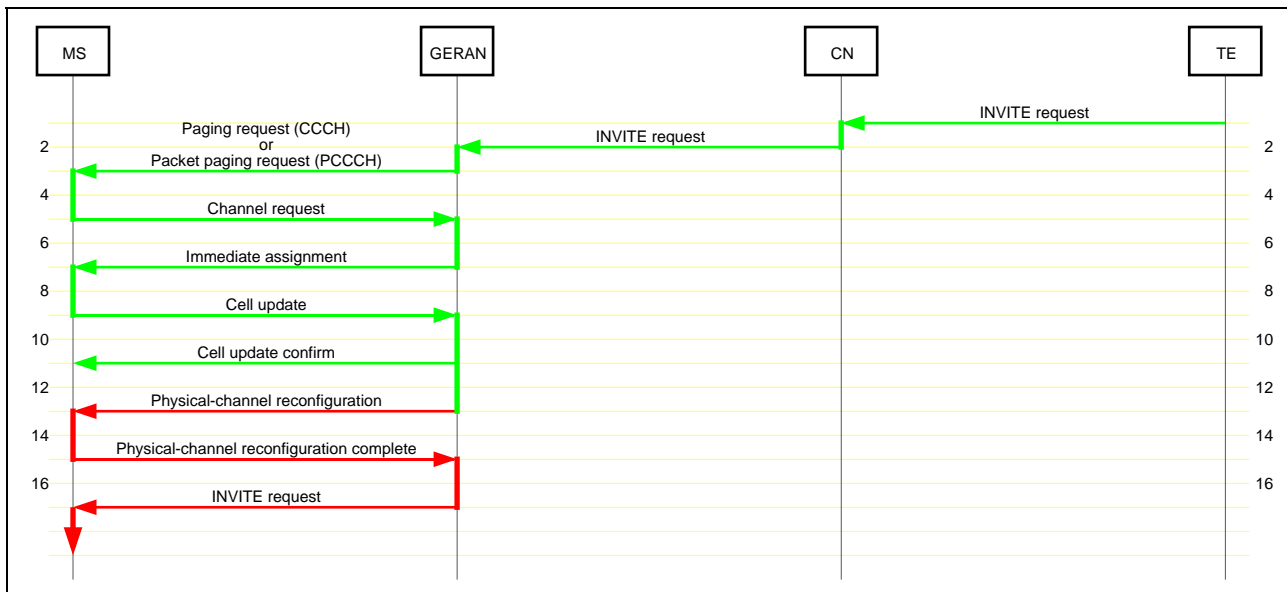

Line	Description	Direction Protocol Channel
1	INVITE request Lloyd's customer calls. The TE calling-user agent initiates the voice call by sending an <i>INVITE request</i> to Lloyd's SIP URL (Session Initiation Protocol Uniform Resource Locator). Based on the context associated with the URL and the contents of the SIP message, the CN determines that it can reach the mobile station via a radio access bearer (RAB).	CN←TE SIP
2	INVITE request Same as § 2.3.2 line 2.	GERAN←CN GTP RABx (<i>Iu-ps</i>)
3a	Paging request { <i>page mode, channel needed, mobile identity, PI rest octets</i> } Since the GERAN RRC is in <i>RRC-GRA_PCH</i> state for this IMSI, it knows where the mobile station is within a GERAN registration area. It therefore sends a GERAN-initiated <i>paging request</i> on all paging channels in the GRA. <ul style="list-style-type: none"> <i>Channel needed</i> indicates SDCCH. It could also indicate TCH. <i>Mobile identity</i> is the mobile station's G-RNTI. <i>PI rest octets</i> indicates <i>paging procedure for RR connection establishment</i>. <Presently, RRC only includes this information if mobile identity is IMSI.> Change the <i>paging request</i> as specified in § 2.1.2.	MS←GERAN RRC CCCH (PCH)
3b	Packet paging request { <i>page mode, persistence level, NLN, page info (TBF or dedicated, mobile identity, channel needed)</i> } Since the GERAN RRC is in <i>RRC-GRA_PCH</i> state for this IMSI, it knows where the mobile station is within a GRA. It therefore has MAC send a GERAN-initiated <i>packet paging request</i> on all paging channels in the GRA. <ul style="list-style-type: none"> <i>TBF or dedicated</i> indicates establishment of a dedicated connection. <i>Mobile identity</i> is the mobile station's G-RNTI. <i>Channel needed</i> indicates SDCCH. It could also indicate TCH. Change the <i>packet paging request</i> as specified in § 2.1.2.	MS←GERAN MAC PCCCH (PPCH)
5	Channel request { <i>establishment cause, random reference</i> } Same as § 2.1.1 line 5.	MS→GERAN RRC CCCH (RACH)

7	<p>Immediate assignment <i>{page mode, dedicated mode or TBF, channel description, request reference, timing advance, mobile allocation, starting time, IA rest octets (frequency parameters before time)}</i></p> <p>Same as § 2.1.1 line 7.</p>	<p>MS←GERAN RRC CCCH (AGCH)</p>
9	<p>Cell update <i>{U-RNTI, START list, AM_RLC error indication (RB2 or RB3), AM_RLC error indication (RB4 and upwards), cell-update cause, RB-timer indicator}</i></p> <p>Same as § 2.1.3 line 9.</p>	<p>MS→GERAN RRC RB1 (SDCCH)</p>
11	<p>Cell update confirm <i>{RRC transaction identifier, activation time, RRC state indicator, UTRAN DRX cycle length coefficient, RLC re-establish indicator (RB2 and RB3), RLC re-establish indicator (RB4 and upwards), <channel and radio-resource configuration information elements (reams of information elements of dubious usefulness)>}</i></p> <p>Same as § 2.1.3 line 11.</p>	<p>MS←GERAN RRC RB1 (SDCCH)</p>
13	<p>Physical-channel reconfiguration <i>{<parameters to be determined>}</i></p> <p>The GERAN RRC assigns a dedicated physical subchannel. The dedicated channel will carry RBx, the radio bearer for RABx.</p> <p><i>Add a physical-channel reconfiguration message based on the 25.331 message of the same name.</i></p>	<p>MS←GERAN RRC RB2 (SDCCH)</p>
15	<p>Physical-channel reconfiguration complete <i>{<parameters to be determined>}</i></p> <p>The MS RRC confirms reconfiguration of the physical layer.</p> <p><i>Add a physical-channel reconfiguration complete message based on the 25.331 message of the same name.</i></p>	<p>MS→GERAN RRC RB2 (SDCCH)</p>
17	<p>INVITE request</p> <p>GERAN delivers the INVITE request to the mobile station.</p>	<p>MS←GERAN PDCP RBx (PDTCH)</p>

1 2.4 Incoming packet voice call – assign shared channel

2 In this section, a packet voice call will arrive over the *Iu-ps* interface. The GERAN RRC assigns a shared channel for
3 the mobile station to respond to the page.

4 Sequences assume the following:

- 5 • TBFs persist long enough for transactions to proceed without multiple channel requests and assignments.
- 6 • Multiple signalling radio bearers can share a TBF.
- 7 • The MS and GERAN use one-phase packet access.

8 2.4.1 *RRC-Idle*, CCCH

9 This sequence corresponds to the following user-based scenario:

- 10 • Lloyd receives a voice call.

11 Figure 8 shows the paging-related portion of an incoming packet voice call under the following conditions:

- 12 • RRC is in *RRC-Idle* mode.
- 13 • MM is in *MM-Idle* state.
- 14 • PMM is in *PMM-Idle* state.
- 15 • MAC is in *MAC-Idle* state; the mobile station monitors a CCCH.

Figure 8: Incoming packet voice call – RRC-Idle, CCCH, assign shared channel

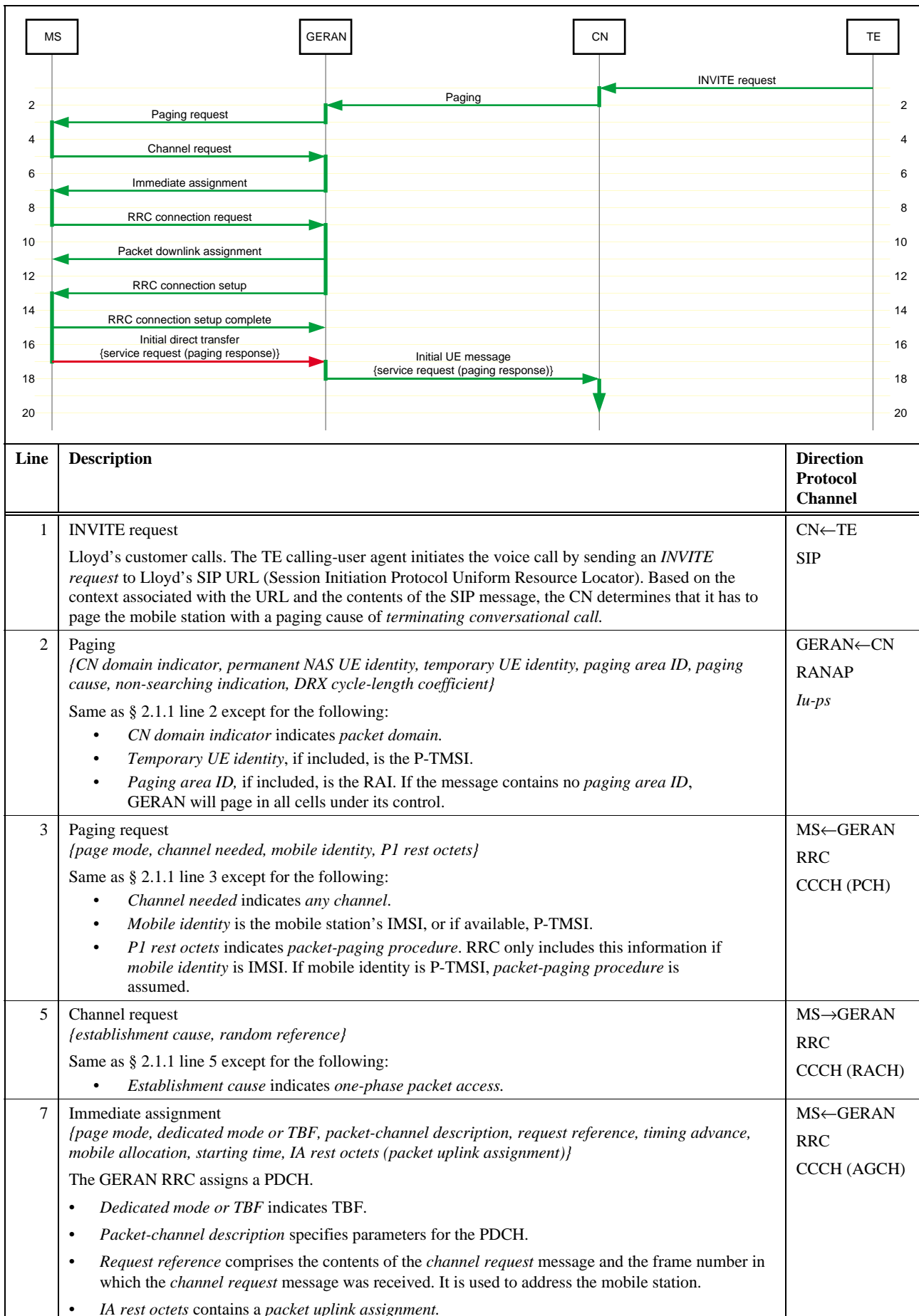

9	RRC connection request <i>{initial UE identity, establishment cause}</i> Same as § 2.1.1 line 9 except for the following: <ul style="list-style-type: none"> • <i>Initial UE identity</i> indicates IMSI, or if available, P-TMSI. • <i>Establishment cause</i> indicates <i>terminating conversational call</i>. 	MS→GERAN RRC PDTCH
11	Packet downlink assignment <i>{page mode, persistence level, global TFI, MAC mode, RLC mode, control ack, timeslot allocation, packet timing advance, P0, BTS pwr-control mode, PR mode, frequency parameters, downlink TFI assignment, power-control parameters, TBF starting time, measurement mapping}</i> Under control of the GERAN RRC, the GERAN MAC allocates a downlink TBF so that the GERAN RRC can reply. <ul style="list-style-type: none"> • <i>Global TFI</i> is the uplink TFI assigned in line 7. It is used to address the mobile station. • <i>MAC mode</i> indicates any of the four allocation modes: dynamic, extended dynamic, fixed, fixed half-duplex. • <i>RLC mode</i> indicates <i>acknowledged</i>. • <i>Downlink TFI assignment</i> assigns a TFI for the downlink TBF. 	MS←GERAN MAC PACCH
13	RRC connection setup <i>{initial UE identity, RRC transaction identifier, new G-RNTI, RRC state indicator, UTRAN DRX cycle-length coefficient, signalling RB information setup list}</i> Same as § 2.1.1 line 11 except for the following: <ul style="list-style-type: none"> • <i>Initial UE identity</i> indicates IMSI, or if available, P-TMSI. • <i>RRC state indicator</i> specifies that the mobile station enter <i>RRC-Cell_Shared</i> state. 	MS←GERAN RRC PDTCH
15	RRC connection setup complete <i>{RRC transaction identifier, START list, UE radio access capability}</i> Same as § 2.1.1 line 13 except for the following: <ul style="list-style-type: none"> • <i>START list</i> identifies the CN domain (packet) and initializes the 20 most-significant bits of the hyperframe numbers. 	MS→GERAN RRC RB2 (PDTCH)
17	Initial direct transfer <i>{CN domain identity, intra-domain NAS node selector, NAS message}</i> The MS RRC initiates a signaling connection to the packet CN and forwards the MS NAS paging response. <ul style="list-style-type: none"> • <i>CN domain identity</i> indicates <i>packet domain</i>. • <i>Intra-domain NAS node selector</i> indicates the NAS node to which the MS wants to establish a connection. • <i>NAS message</i> contains the <i>service request</i> message indicating <i>paging response</i>. 	MS→GERAN RRC RB3 (PDTCH)
18	Initial UE message <i>{CN domain indicator, LAI, RAC, SAI, NAS-PDU, Iu signalling-connection identifier, Global RNC-ID}</i> Same as § 2.1.1 line 16 except for the following: <ul style="list-style-type: none"> • <i>CN domain indicator</i> indicates <i>packet domain</i>. • <i>RAC</i> indicates the routing area in which the RRC connection exists. 	GERAN→CN RANAP <i>Iu-ps</i>

1

2 2.4.2 RRC-Idle, PCCCH

3 This sequence corresponds to the following user-based scenario:

- 4
- Lloyd receives a voice call.

5 Figure 9 shows the paging-related portion of an incoming packet voice call under the following conditions:

- 6
- RRC is in *RRC-Idle* mode.
 - 7
 - MM is in *MM-Idle* state.
 - 8
 - PMM is in *PMM-Idle* state.
 - 9
 - MAC is in *MAC-Idle* state; the mobile station monitors a PCCCH.

Figure 9: Incoming packet voice call – RRC Idle, PCCCH, assign shared channel

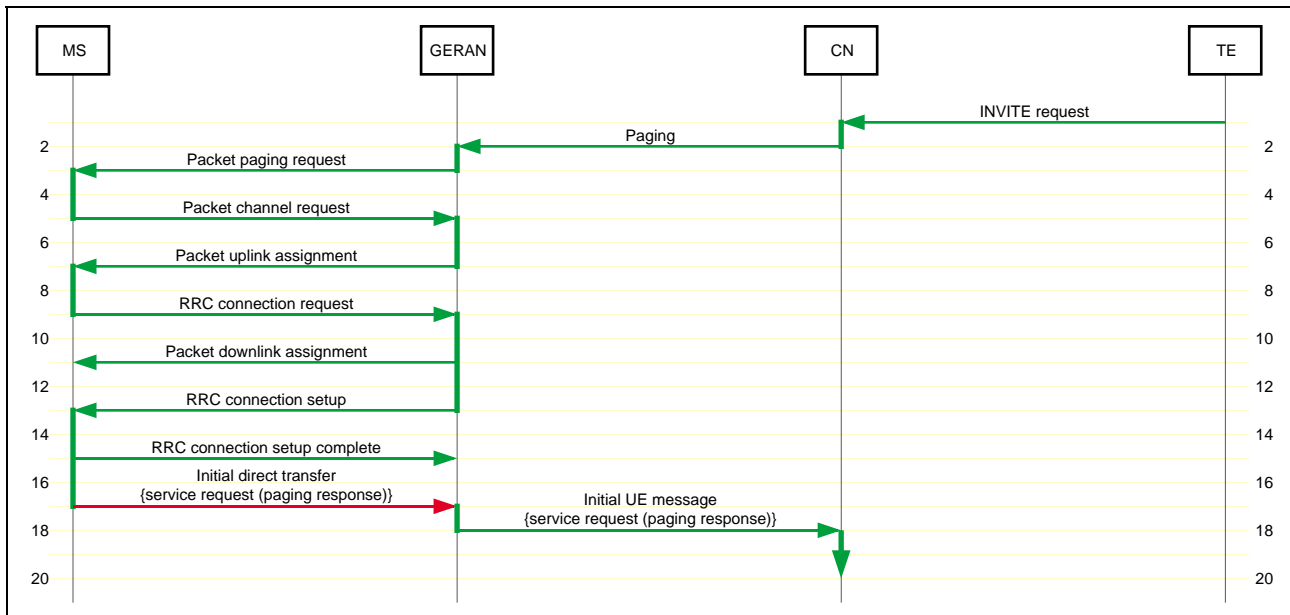

Line	Description	Direction Protocol Channel
1	INVITE request Lloyd's customer calls. The TE calling-user agent initiates the voice call by sending an <i>INVITE request</i> to Lloyd's SIP URL (Session Initiation Protocol Uniform Resource Locator). Based on the context associated with the URL and the contents of the SIP message, the CN determines that it has to page the mobile station with a paging cause of <i>terminating conversational call</i> .	CN←TE SIP
2	Paging { <i>CN domain indicator, permanent NAS UE identity, temporary UE identity, paging area ID, paging cause, non-searching indication, DRX cycle-length coefficient</i> } Same as § 2.4.1 line 2.	GERAN←CN RANAP <i>Iu-ps</i>
3	Packet paging request { <i>page mode, persistence level, NLN, page info (TBF or dedicated, mobile identity, channel needed)</i> } Same as 2.1.1 line 3b except for the following: <ul style="list-style-type: none"> • <i>TBF or dedicated</i> indicates TBF establishment. • <i>Mobile identity</i> is the mobile station's IMSI, or if available, P-TMSI. • <i>Channel needed</i> is not sent because this information element only applies to circuit calls. 	MS←GERAN RRC PCCCH (PPCH)
5	Packet channel request { <i>establishment cause, random bits</i> } Under control of the MS RRC, the MS MAC requests a channel to respond to the page. <ul style="list-style-type: none"> • <i>Establishment cause</i> indicates <i>page response</i>. <Should <i>establishment cause</i> indicate <i>one-phase access</i>?> 	MS→GERAN RRC PCCCH (PRACH)
7	Packet uplink assignment { <i>page mode, persistence level, packet-request reference, channel-coding command, TLLI-block channel coding, packet timing advance, frequency parameters, allocation (uplink TFI assignment)</i> } Under control of the GERAN RRC, the GERAN MAC allocates an uplink TBF. <ul style="list-style-type: none"> • <i>Packet-request reference</i> comprises the contents of the <i>packet channel request</i> and the frame number in which the GERAN MAC received the <i>packet channel request</i>. It is used to address the mobile station. • <i>Uplink TFI assignment</i> assigns a TFI for the uplink TBF. 	MS←GERAN RRC PCCCH (PAGCH)
9	RRC connection request { <i>initial UE identity, establishment cause</i> } Same as § 2.4.1 line 9.	MS→GERAN RRC PDTCH

11	Packet downlink assignment <i>{page mode, persistence level, global TFI, MAC mode, RLC mode, control ack, timeslot allocation, packet timing advance, P0, BTS pwr-control mode, PR mode, frequency parameters, downlink TFI assignment, power-control parameters, TBF starting time, measurement mapping}</i> Same as § 2.4.1 line 11.	MS←GERAN MAC PACCH
13	RRC connection setup <i>{initial UE identity, RRC transaction identifier, new G-RNTI, RRC state indicator, UTRAN DRX cycle-length coefficient, signalling RB information setup list}</i> Same as § 2.4.1 line 13.	MS←GERAN RRC PDTCH
15	RRC connection setup complete <i>{RRC transaction identifier, START list, UE radio access capability}</i> Same as § 2.4.1 line 15.	MS→GERAN RRC RB2 (PDTCH)
17	Initial direct transfer <i>{CN domain identity, intra-domain NAS node selector, NAS message}</i> Same as § 2.4.1 line 17.	MS→GERAN RRC RB3 (PDTCH)
18	Initial UE message <i>{CN domain indicator, LAI, RAC, SAI, NAS-PDU, Iu signalling-connection identifier, Global RNC-ID}</i> Same as § 2.4.1 line 18.	GERAN→CN RANAP <i>Iu-ps</i>

1

2 2.4.3 RRC-GRA_PCH, CCCH

3 This sequence corresponds to the following user-based scenario:

- 4 • Lloyd receives a voice call.

5 Figure 10 shows the paging-related portion of an incoming packet voice call under the following conditions:

- 6 • RRC is in *RRC-GRA_PCH* state.
- 7 • MM is in *MM-Idle* state.
- 8 • PMM is in *PMM-Connected* state.
- 9 • MAC is in *MAC-Idle* state; the mobile station monitors a CCCH.

Figure 10: Incoming packet voice call – RRC-GRA_PCH, CCCH, assign shared channel

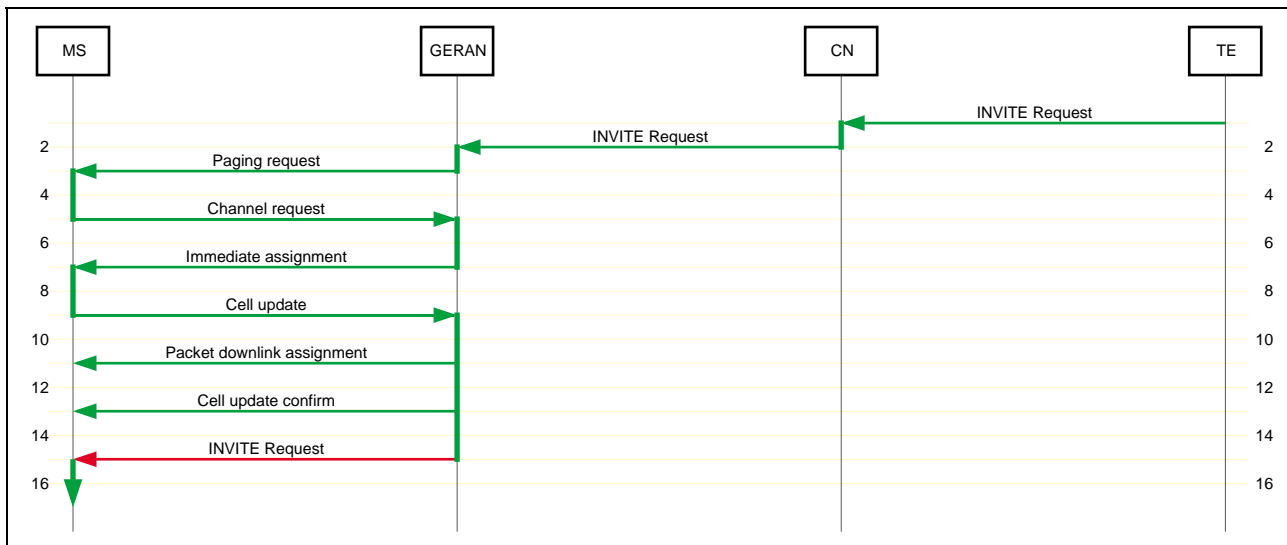

Line	Description	Direction Protocol Channel
1	INVITE request Lloyd's customer calls. The TE calling-user agent initiates the voice call by sending an <i>INVITE request</i> to Lloyd's SIP URL (Session Initiation Protocol Uniform Resource Locator). Based on the context associated with the URL and the contents of the SIP message, the CN determines that it can reach the mobile station via a radio access bearer (RAB).	CN←TE SIP
2	INVITE request Since the CN still has an <i>Iu</i> connection for this mobile station, it sends the INVITE request to GERAN via the RAB established for this purpose: RABx.	GERAN←CN GTP RABx (<i>Iu-ps</i>)
3	Paging request <i>{page mode, channel needed, mobile identity, P1 rest octets}</i> Since the GERAN RRC is in <i>GRA_PCH</i> state for this IMSI, it knows where the mobile station is within a GERAN registration area. It therefore sends a GERAN-initiated <i>paging request</i> on all paging channels in the GRA. <ul style="list-style-type: none"><i>Channel needed</i> indicates any channel.<i>Mobile identity</i> is the mobile station's G-RNTI.<i>P1 rest octets</i> indicates <i>packet-paging procedure</i>. <Presently, RRC only includes this information if <i>mobile identity</i> is IMSI.> <Since this is a GERAN-initiated page, how does GERAN know which DRX parameters to use, especially if the mobile station has changed <i>SPLIT_PG_CYCLE</i> and the CN hasn't sent a RANAP <i>paging</i> message to GERAN.> Change the <i>paging request</i> as specified in § 2.1.2.	MS←GERAN RRC CCCH (PCH)
5	Channel request <i>{establishment cause, random reference}</i> Same as § 2.4.1 line 5.	MS→GERAN RRC CCCH (RACH)
7	Immediate assignment <i>{page mode, dedicated mode or TBF, packet-channel description, request reference, timing advance, mobile allocation, starting time, IA rest octets (packet uplink assignment)}</i> Same as § 2.4.1 line 7.	MS←GERAN RRC CCCH (AGCH)
9	Cell update <i>{U-RNTI, START list, AM_RLC error indication (RB2 or RB3), AM_RLC error indication (RB4 and upwards), cell-update cause, RB-timer indicator}</i> Same as § 2.1.3 line 9 except for the following: <ul style="list-style-type: none"><i>START list</i> identifies the CN domain (packet) and initializes the 20 most-significant bits of the hyperframe numbers.	MS→GERAN RRC RB1 (PDTCH)

11	<p>Packet downlink assignment <i>{page mode, persistence level, global TFI, MAC mode, RLC mode, control ack, timeslot allocation, packet timing advance, P0, BTS pwr-control mode, PR mode, frequency parameters, downlink TFI assignment, power-control parameters, TBF starting time, measurement mapping}</i></p> <p>Same as § 2.4.1 line 11.</p>	<p>MS←GERAN MAC PACCH</p>
13	<p>Cell update confirm <i>{RRC transaction identifier, activation time, RRC state indicator, UTRAN DRX cycle length coefficient, RLC re-establish indicator (RB2 and RB3), RLC re-establish indicator (RB4 and upwards), <channel and radio-resource configuration information elements (reams of information elements of dubious usefulness)>}</i></p> <p>Same as § 2.1.3 line 11 except for the following:</p> <ul style="list-style-type: none"> • <i>RRC state indicator</i> specifies that the mobile station enter <i>RRC-Cell_Shared</i> state. 	<p>MS←GERAN RRC RB1 (PDTCH)</p>
15	<p>INVITE request GERAN forwards the <i>INVITE request</i> to the MS.</p>	<p>MS←GERAN PDCP RBx (PDTCH)</p>

1

2 2.4.4 RRC-GRA_PCH, PCCCH

3 This sequence corresponds to the following user-based scenario:

- 4 • Lloyd receives a voice call.

5 Figure 11 shows the paging-related portion of an incoming packet voice call under the following conditions:

- 6 • RRC is in *RRC-GRA_PCH* state.
- 7 • MM is in *MM-Idle* state.
- 8 • PMM is in *PMM-Connected* state.
- 9 • MAC is in *MAC-Idle* state; the mobile station monitors a PCCCH.

Figure 11: Incoming packet voice call – RRC-GRA_PCH, PCCCH, assign shared channel

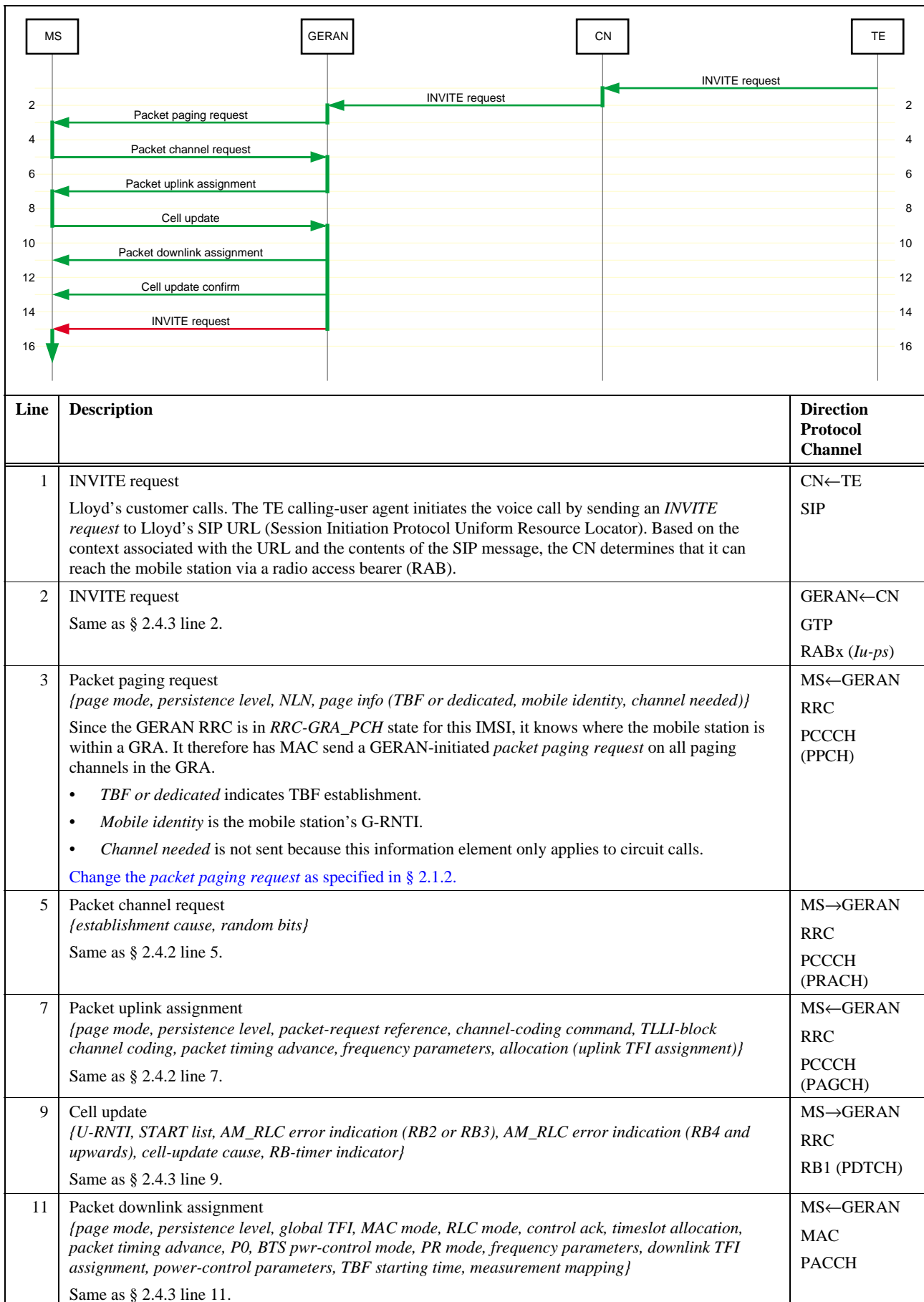

13	<p>Cell update confirm <i>{RRC transaction identifier, activation time, RRC state indicator, UTRAN DRX cycle length coefficient, RLC re-establish indicator (RB2 and RB3), RLC re-establish indicator (RB4 and upwards), <channel and radio-resource configuration information elements (reams of information elements of dubious usefulness)>}</i> Same as § 2.4.3 line 13.</p>	<p>MS←GERAN RRC RB1 (PDTCH)</p>
15	<p>INVITE request GERAN forwards the <i>INVITE request</i> to the MS.</p>	<p>MS←GERAN PDCP RBx (PDTCH)</p>

1 2.5 Incoming packet data transfer – assign dedicated channel

2 In this section, packet data will arrive over the *Iu-ps* interface. The GERAN RRC assigns a dedicated channel for the
3 mobile station to respond to the page.

4 Sequences assume the following:

- 5 • The server initiates transfer of the e-mail; the client does not poll for e-mail.

6 2.5.1 *RRC-Cell_Dedicated*

7 This sequence corresponds to the following user-based scenario:

- 8 • Lloyd receives an e-mail order confirmation while engaged in a voice call.

9 Figure 12 shows the paging-related portion of an incoming data transfer under the following conditions:

- 10 • RRC is in *RRC-Cell_Dedicated* state.
- 11 • MM is in *MM-Connected* state.
- 12 • PMM is in *PMM-Idle* state.
- 13 • MAC is in *MAC-Dedicated* state; the mobile station is on a TCH.

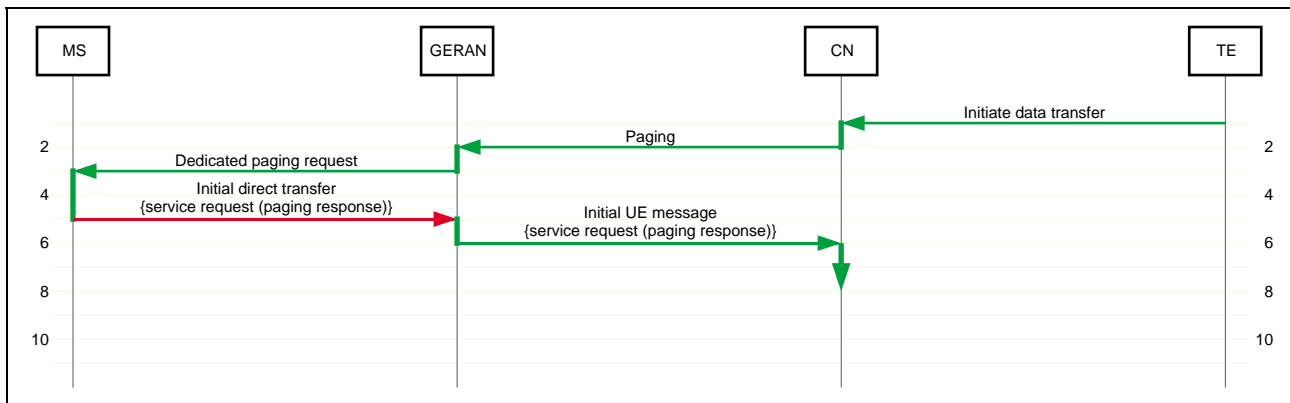
Figure 12: Incoming packet data transfer – *RRC-Cell_Dedicated*, assign dedicated channel

Line	Description	Direction Protocol Channel
1	Initiate data transfer Lloyd's server sends an e-mail confirming a customer order. Lloyd is talking to one of his customers.	CN←TE
2	Paging {CN domain indicator, permanent NAS UE identity, temporary UE identity, paging area ID, paging cause, non-searching indication, DRX cycle-length coefficient} Same as § 2.1.1 line 2 except for the following: <ul style="list-style-type: none"> • CN domain indicator indicates packet domain. • Temporary UE identity, if included, is the P-TMSI. • Paging area ID, if included, is the RAI. If the message contains no paging area ID, GERAN will page in all cells under its control. • Paging cause, if included, indicates terminating background call. 	GERAN←CN RANAP <i>Iu-ps</i>
3	Dedicated paging request {RRC transaction identifier, paging cause, CN domain identity, paging record type identifier} Since the GERAN RRC is in <i>RRC-Cell_Dedicated</i> state for this IMSI, it knows where the mobile station is and it has radio bearers established to that mobile station. It therefore sends a CN-initiated <i>dedicated paging request</i> on RB2. Upon receipt of the <i>dedicated paging request</i> , the MS RRC informs its non-access stratum that the core network has paged it. The MS NAS responds to the page. <ul style="list-style-type: none"> • RRC transaction identifier identifies the transaction. Subsequent messages in the transaction use this identifier. • Paging cause indicates terminating background call. • CN domain identity indicates packet domain. • Paging record type identifier indicates P-TMSI. <Does it really indicate P-TMSI, and if so, why?> <p>The following should be added to 44.018:</p> <ul style="list-style-type: none"> • A dedicated paging request based on 25.331 paging type 2. 	MS←GERAN RRC RB2 (FACCH)
5	Initial direct transfer {CN domain identity, intra-domain NAS node selector, NAS message} The MS RRC initiates a signaling connection to the packet CN and forwards the MS NAS paging response. <ul style="list-style-type: none"> • CN domain identity indicates packet domain. • Intra-domain NAS node selector indicates the NAS node to which the MS wants to establish a connection. • NAS message contains the service request message indicating paging response. 	MS→GERAN RRC RB3 (FACCH)
6	Initial UE message {CN domain indicator, LAI, RAC, SAI, NAS-PDU, Iu signalling-connection identifier, Global RNC-ID} Same as § 2.1.1 line 16 except for the following: <ul style="list-style-type: none"> • CN domain indicator indicates packet domain. • RAC indicates the routing area in which the RRC connection exists. 	GERAN→CN RANAP <i>Iu-ps</i>

1 2.6 Incoming packet data transfer – assign shared channel

2 In this section, the GERAN RRC assigns a shared channel for the mobile station to respond to the page.

3 Sequences assume the following:

- 4 • The server initiates transfer of the e-mail; the client does not poll for e-mail.
- 5 • TBFs persist long enough for transactions to proceed without multiple channel requests and assignments.
- 6 • Multiple signalling radio bearers can share a TBF.
- 7 • The MS and GERAN use one-phase packet access.

8 2.6.1 *RRC-Idle*, CCCH

9 This sequence corresponds to the following user-based scenario:

- 10 • Lloyd receives an e-mail order confirmation.

11 Figure 13 shows the paging-related portion of an incoming data transfer under the following conditions:

- 12 • RRC is in *RRC-Idle* mode.
- 13 • MM is in *MM-Idle* state.
- 14 • PMM is in *PMM-Idle* state.
- 15 • MAC is in *MAC-Idle* state; the mobile station monitors a CCCH.

Figure 13: Incoming packet data transfer – RRC-Idle, CCCH, assign shared channel

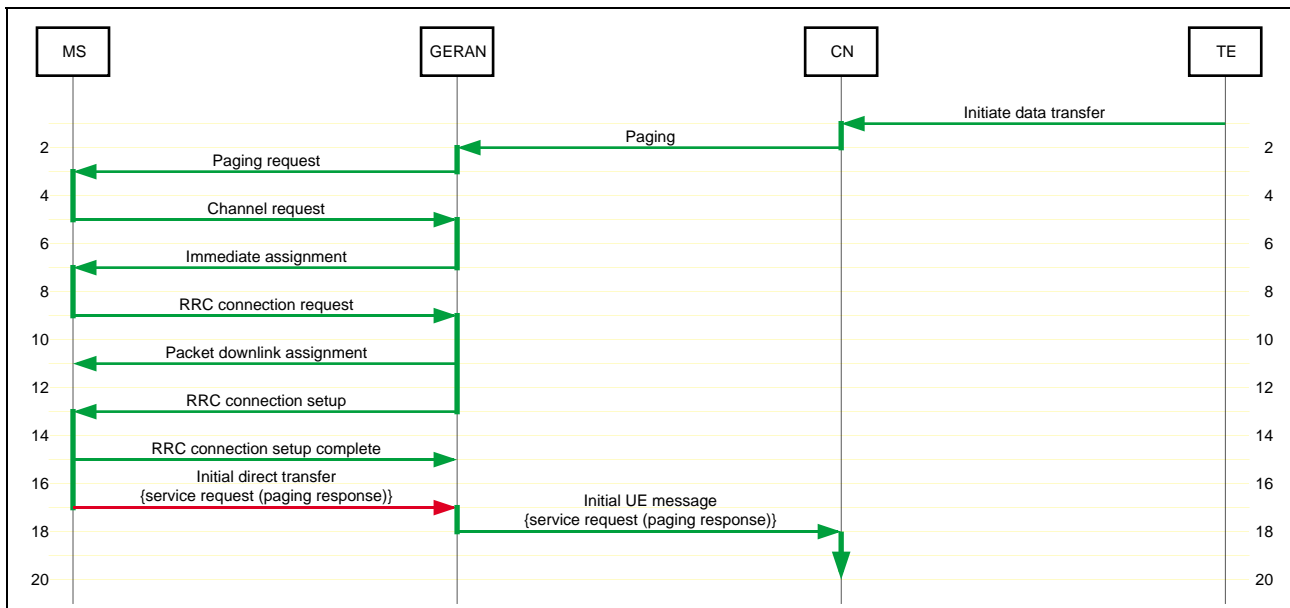

Line	Description	Direction Protocol Channel
1	Initiate data transfer Lloyd's server sends an e-mail confirming a customer order.	CN←TE
2	Paging {CN domain indicator, permanent NAS UE identity, temporary UE identity, paging area ID, paging cause, non-searching indication, DRX cycle-length coefficient} Same as § 2.5.1 line 2.	GERAN←CN RANAP <i>lu-ps</i>
3	Paging request {page mode, channel needed, mobile identity, P1 rest octets} Same as § 2.1.1 line 3 except for the following: <ul style="list-style-type: none"> Channel needed indicates any channel. Mobile identity is the mobile station's IMSI, or if available, P-TMSI. P1 rest octets indicates packet-paging procedure. RRC only includes this information if mobile identity is IMSI. 	MS←GERAN RRC CCCH (PCH)
5	Channel request {establishment cause, random reference} Same as § 2.1.1 line 5 except for the following: <ul style="list-style-type: none"> Establishment cause indicates one-phase packet access. 	MS→GERAN RRC CCCH (RACH)
7	Immediate assignment {page mode, dedicated mode or TBF, packet-channel description, request reference, timing advance, mobile allocation, starting time, IA rest octets (packet uplink assignment)} The GERAN RRC assigns a PDCH. <ul style="list-style-type: none"> Dedicated mode or TBF indicates TBF. Packet-channel description specifies parameters for the PDCH. Request reference comprises the contents of the channel request message and the frame number in which the channel request message was received. It is used to address the mobile station. IA rest octets contains a packet uplink assignment. 	MS←GERAN RRC CCCH (AGCH)
9	RRC connection request {initial UE identity, establishment cause} Same as § 2.1.1 line 9 except for the following: <ul style="list-style-type: none"> Initial UE identity indicates IMSI, or if available, P-TMSI. Establishment cause indicates terminating background call. 	MS→GERAN RRC PDTCH

11	<p>Packet downlink assignment <i>{page mode, persistence level, global TFI, MAC mode, RLC mode, control ack, timeslot allocation, packet timing advance, P0, BTS pwr-control mode, PR mode, frequency parameters, downlink TFI assignment, power-control parameters, TBF starting time, measurement mapping}</i></p> <p>Under control of the GERAN RRC, the GERAN MAC allocates a downlink TBF so that the GERAN RRC can reply.</p> <ul style="list-style-type: none"> • <i>Global TFI</i> is the uplink TFI assigned in line 7. It is used to address the mobile station. • <i>MAC mode</i> indicates any of the four allocation modes: dynamic, extended dynamic, fixed, fixed half-duplex. • <i>RLC mode</i> indicates <i>acknowledged</i>. • <i>Downlink TFI assignment</i> assigns a TFI for the downlink TBF. 	MS←GERAN MAC PACCH
13	<p>RRC connection setup <i>{initial UE identity, RRC transaction identifier, new G-RNTI, RRC state indicator, UTRAN DRX cycle-length coefficient, signalling RB information setup list}</i></p> <p>Same as § 2.1.1 line 11 except for the following:</p> <ul style="list-style-type: none"> • <i>Initial UE identity</i> indicates IMSI, or if available, P-TMSI. • <i>RRC state indicator</i> specifies that the mobile station enter <i>RRC-Cell_Shared</i> state. 	MS←GERAN RRC PDTCH
15	<p>RRC connection setup complete <i>{RRC transaction identifier, START list, UE radio access capability}</i></p> <p>Same as § 2.1.1 line 13 except for the following:</p> <ul style="list-style-type: none"> • <i>START list</i> identifies the CN domain (packet) and initializes the 20 most-significant bits of the hyperframe numbers. 	MS→GERAN RRC RB2 (PDTCH)
17	<p>Initial direct transfer <i>{CN domain identity, intra-domain NAS node selector, NAS message}</i></p> <p>The MS RRC initiates a signaling connection to the packet CN and forwards the MS NAS paging response.</p> <ul style="list-style-type: none"> • <i>CN domain identity</i> indicates <i>packet domain</i>. • <i>Intra-domain NAS node selector</i> indicates the NAS node to which the MS wants to establish a connection. • <i>NAS message</i> contains the <i>service request</i> message indicating <i>paging response</i>. 	MS→GERAN RRC RB3 (PDTCH)
18	<p>Initial UE message <i>{CN domain indicator, LAI, RAC, SAI, NAS-PDU, lu signalling-connection identifier, Global RNC-ID}</i></p> <p>Same as § 2.1.1 line 16 except for the following:</p> <ul style="list-style-type: none"> • <i>CN domain indicator</i> indicates <i>packet domain</i>. • <i>RAC</i> indicates the routing area in which the RRC connection exists. 	GERAN→CN RANAP <i>lu-ps</i>

1

2 2.6.2 RRC-Idle, PCCCH

3 This sequence corresponds to the following user-based scenario:

- 4
- Lloyd receives an e-mail order confirmation.

5 Figure 14 shows the paging-related portion of an incoming data transfer under the following conditions:

- 6
- RRC is in *RRC-Idle* mode.
 - 7
 - MM is in *MM-Idle* state.
 - 8
 - PMM is in *PMM-Idle* state.
 - 9
 - MAC is in *MAC-Idle* state; the mobile station monitors a PCCCH.

Figure 14: Incoming packet data transfer – RRC Idle, PCCCH, assign shared channel

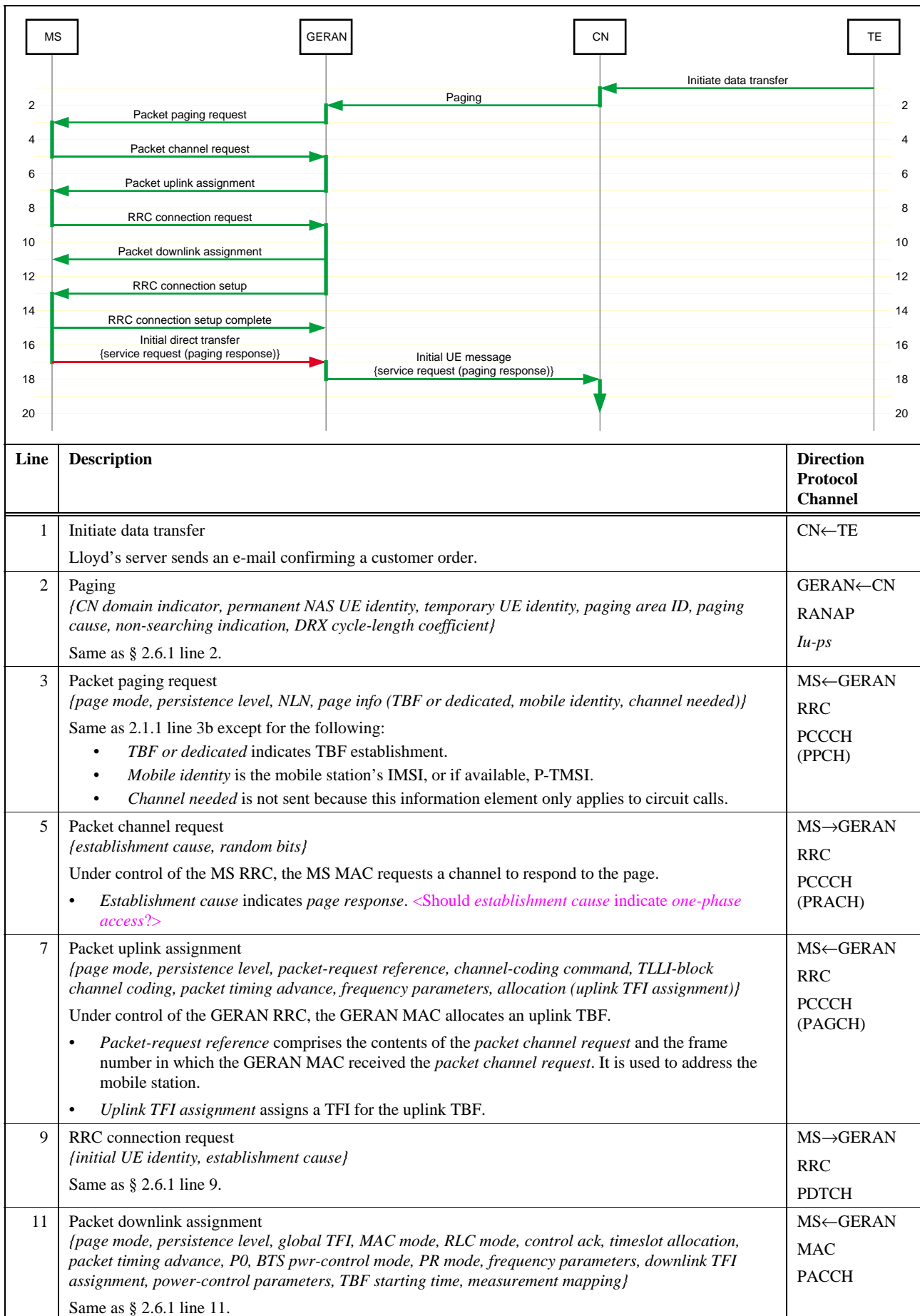

13	RRC connection setup <i>{initial UE identity, RRC transaction identifier, new G-RNTI, RRC state indicator, UTRAN DRX cycle-length coefficient, signalling RB information setup list}</i> Same as § 2.6.1 line 13.	MS←GERAN RRC PDTCH
15	RRC connection setup complete <i>{RRC transaction identifier, START list, UE radio access capability}</i> Same as § 2.6.1 line 15.	MS→GERAN RRC RB2 (PDTCH)
17	Initial direct transfer <i>{CN domain identity, intra-domain NAS node selector, NAS message}</i> Same as § 2.6.1 line 17.	MS→GERAN RRC RB3 (PDTCH)
18	Initial UE message <i>{CN domain indicator, LAI, RAC, SAI, NAS-PDU, Iu signalling-connection identifier, Global RNC-ID}</i> Same as § 2.6.1 line 18.	GERAN→CN RANAP <i>Iu-ps</i>

1

2 2.6.3 RRC-GRA_PCH, CCCH

3 This sequence corresponds to the following user-based scenario:

- 4 • Lloyd receives an e-mail order confirmation.

5 Figure 15 shows the paging-related portion of an incoming data transfer under the following conditions:

- 6 • RRC is in *RRC-GRA_PCH* state.
- 7 • MM is in *MM-Idle* state.
- 8 • PMM is in *PMM-Connected* state.
- 9 • MAC is in *MAC-Idle* state; the mobile station monitors a CCCH.

Figure 15: Incoming packet data transfer – RRC-GRA_PCH, CCCH, assign shared channel

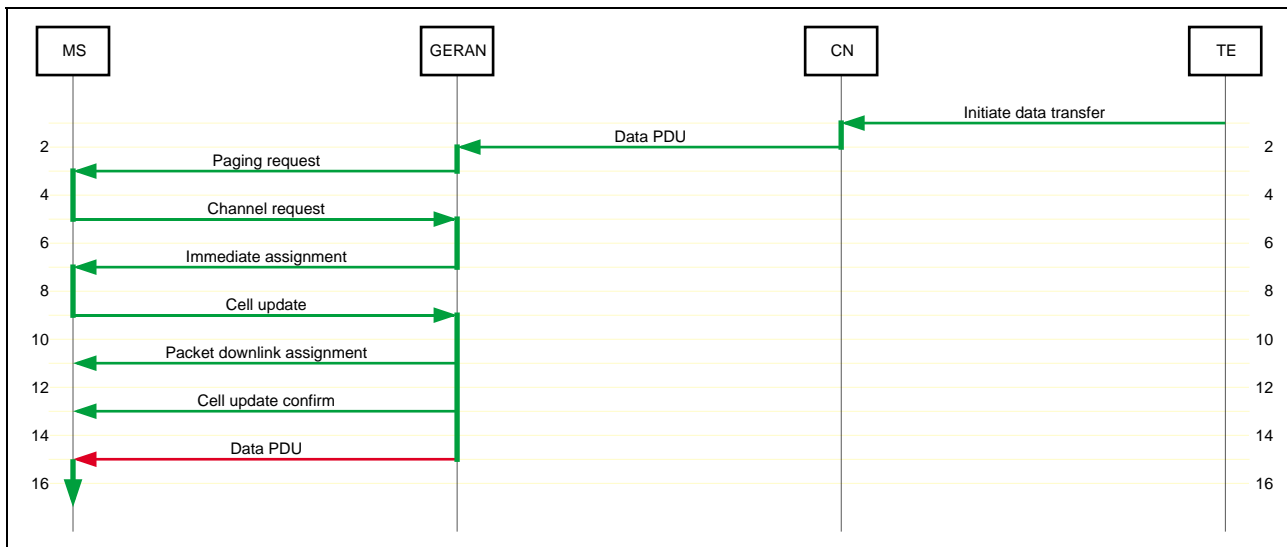

Line	Description	Direction Protocol Channel
1	Initiate data transfer Lloyd's server sends an e-mail confirming a customer order.	CN←TE
2	Data PDU Since the CN still has an <i>Iu</i> connection for this mobile station, it sends the data PDU to GERAN via the RAB established for this purpose: RABx.	GERAN←CN GTP RABx (<i>Iu-ps</i>)
3	Paging request <i>{page mode, channel needed, mobile identity, P1 rest octets}</i> Since the GERAN RRC is in <i>GRA_PCH</i> state for this IMSI, it knows where the mobile station is within a GERAN registration area. It therefore sends a GERAN-initiated <i>paging request</i> on all paging channels in the GRA. <ul style="list-style-type: none"> <i>Channel needed</i> indicates any channel. <i>Mobile identity</i> is the mobile station's G-RNTI. <i>P1 rest octets</i> indicates <i>packet-paging procedure</i>. <Presently, RRC only includes this information if mobile identity is IMSI.> Change the <i>paging request</i> as specified in § 2.1.2.	MS←GERAN RRC CCCH (PCH)
5	Channel request <i>{establishment cause, random reference}</i> Same as § 2.6.1 line 5.	MS→GERAN RRC CCCH (RACH)
7	Immediate assignment <i>{page mode, dedicated mode or TBF, packet-channel description, request reference, timing advance, mobile allocation, starting time, IA rest octets (packet uplink assignment)}</i> Same as § 2.6.1 line 7.	MS←GERAN RRC CCCH (AGCH)
9	Cell update <i>{U-RNTI, START list, AM_RLC error indication (RB2 or RB3), AM_RLC error indication (RB4 and upwards), cell-update cause, RB-timer indicator}</i> Same as § 2.1.3 line 9 except for the following: <ul style="list-style-type: none"> <i>START list</i> identifies the CN domain (packet) and initializes the 20 most-significant bits of the hyperframe numbers. 	MS→GERAN RRC RB1 (PDTCH)
11	Packet downlink assignment <i>{page mode, persistence level, global TFI, MAC mode, RLC mode, control ack, timeslot allocation, packet timing advance, P0, BTS pwr-control mode, PR mode, frequency parameters, downlink TFI assignment, power-control parameters, TBF starting time, measurement mapping}</i> Same as § 2.6.1 line 11.	MS←GERAN MAC PACCH

13	<p>Cell update confirm <i>{RRC transaction identifier, activation time, RRC state indicator, UTRAN DRX cycle length coefficient, RLC re-establish indicator (RB2 and RB3), RLC re-establish indicator (RB4 and upwards), <channel and radio-resource configuration information elements (reams of information elements of dubious usefulness)>}</i></p> <p>Same as § 2.1.3 line 11 except for the following:</p> <ul style="list-style-type: none"> • <i>RRC state indicator</i> specifies that the mobile station enter <i>RRC-Cell_Shared</i> state. 	<p>MS←GERAN RRC RB1 (PDTCH)</p>
15	<p>Data PDU GERAN forwards the data to the MS.</p>	<p>MS←GERAN PDCP RBx (PDTCH)</p>

1

2 2.6.4 RRC-GRA_PCH, PCCCH

3 This sequence corresponds to the following user-based scenario:

- 4
- Lloyd receives an e-mail order confirmation.

5 Figure 16 shows the paging-related portion of an incoming data transfer under the following conditions:

- 6
- RRC is in *RRC-GRA_PCH* state.
 - 7
 - MM is in *MM-Idle* state.
 - 8
 - PMM is in *PMM-Connected* state.
 - 9
 - MAC is in *MAC-Idle* state; the mobile station monitors a PCCCH.

Figure 16: Incoming packet data transfer – RRC-GRA_PCH, PCCCH, assign shared channel

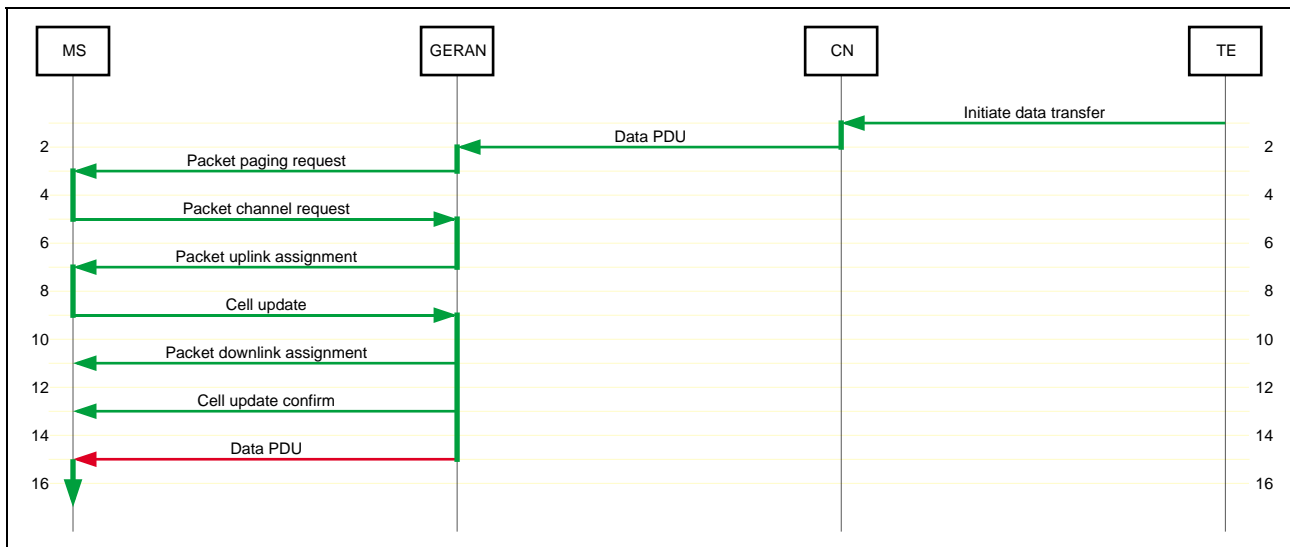

Line	Description	Direction Protocol Channel
1	Initiate data transfer Lloyd's server sends an e-mail confirming a customer order.	CN←TE
2	Data PDU Same as § 2.6.3 line 2.	GERAN←CN GTP RABx (<i>Iu-ps</i>)
3	Packet paging request { <i>page mode, persistence level, NLN, page info (TBF or dedicated, mobile identity, channel needed)</i> } Since the GERAN RRC is in <i>RRC-GRA_PCH</i> state for this IMSI, it knows where the mobile station is within a GRA. It therefore has MAC send a GERAN-initiated <i>packet paging request</i> on all paging channels in the GRA. <ul style="list-style-type: none"> • <i>TBF or dedicated</i> indicates TBF establishment. • <i>Mobile identity</i> is the mobile station's G-RNTI. • <i>Channel needed</i> is not sent because this information element only applies to circuit calls. Change the <i>packet paging request</i> as specified in § 2.1.2.	MS←GERAN RRC PCCCH (PPCH)
5	Packet channel request { <i>establishment cause, random bits</i> } Same as § 2.6.2 line 5.	MS→GERAN RRC PCCCH (PRACH)
7	Packet uplink assignment { <i>page mode, persistence level, packet-request reference, channel-coding command, TLLI-block channel coding, packet timing advance, frequency parameters, allocation (uplink TFI assignment)</i> } Same as § 2.6.2 line 7.	MS←GERAN RRC PCCCH (PAGCH)
9	Cell update { <i>U-RNTI, START list, AM_RLC error indication (RB2 or RB3), AM_RLC error indication (RB4 and upwards), cell-update cause, RB-timer indicator</i> } Same as § 2.6.3 line 9.	MS→GERAN RRC RB1 (PDTCH)
11	Packet downlink assignment { <i>page mode, persistence level, global TFI, MAC mode, RLC mode, control ack, timeslot allocation, packet timing advance, P0, BTS pwr-control mode, PR mode, frequency parameters, downlink TFI assignment, power-control parameters, TBF starting time, measurement mapping</i> } Same as § 2.6.3 line 11.	MS←GERAN MAC PACCH

13	<p>Cell update confirm <i>{RRC transaction identifier, activation time, RRC state indicator, UTRAN DRX cycle length coefficient, RLC re-establish indicator (RB2 and RB3), RLC re-establish indicator (RB4 and upwards), <channel and radio-resource configuration information elements (reams of information elements of dubious usefulness)>}</i> Same as § 2.6.3 line 13.</p>	MS←GERAN RRC RB1 (PDTCH)
15	<p>Data PDU GERAN forwards the data to the MS.</p>	MS←GERAN PDCP RBx (PDTCH)

3. Impact on specifications

This section is incomplete.

3.1 Changes to 23.060 (GPRS stage 2)

Section	Description
	<Are we going to update this standard or leave it alone?>

3.2 Changes to 24.008 (CN protocols)

Section	Description
9.2.15	Location updating request Add <i>DRX parameter</i> . <i>DRX parameter</i> is already specified in § 10.5.5.6.
10.5.1.4	Mobile identity Add G-RNTI as a <i>mobile identity</i> .

3.3 Changes to 25.413 (UTRAN RANAP)

Section	Description
3.3	Abbreviations Add GERAN. Add <i>mobile station</i> to definition of UE.
8.15	Paging Update section to include GERAN paging. Add <i>SPLIT_PG_CYCLE</i> .
9.1.23	Paging Add <i>SPLIT_PG_CYCLE</i> .
9.2	Information-element definitions Add <i>SPLIT_PG_CYCLE</i> .

3.4 Changes to 44.018 (GERAN RRC)

This section proposes changes to GP-011262 (*Draft CR to 44.018 due to RRC Part 1* [Nokia]) and GP-011196 (*Draft CR to 44.018 due to RRC Part 2* [Nokia]).

<If an RRC working draft (44.xxx) is adopted, this section will have to be updated to reflect the structure of the new document.>

Section	Description
3.3.2.1	Paging initiation by the network <Do we need to specify what to do with new information elements in the <i>paging requests</i> ?>
3.3.2.2	Paging response <Changes to this section specify the following: In <i>Iu mode</i> , the upper layer is informed that RRC entity entered the <i>RRC-Cell_Dedicated</i> state. RRC does not enter this state until the RRC connection is established, long after the paging response.>
3.5.1.1	Packet paging initiation by the network <Do we need to specify what to do with new information elements in the <i>packet paging request</i> ?>
3.4	Procedures in RR dedicated mode ... Add subsection specifying paging in <i>RRC-Cell_Dedicated</i> state. See 25.331 § 8.1.11, <i>UE dedicated paging</i> . <How does this relate to 44.018 § 3.4.22.2, <i>Packet notification procedure in dedicated mode</i> ?>
9.1	Paging Add a paging message based on 25.331 <i>paging type 2</i> .
9.1.22	Paging request type 1 For both mobile identities, add the following to the <i>paging request type 1</i> : <ul style="list-style-type: none"> An implicit indication of which network element initiated the page: CN or GERAN. The presence of <i>paging cause</i> indicates a CN-initiated page; the absence of <i>paging cause</i> indicates a GERAN-initiated page. This requires that GERAN fabricate a <i>paging cause</i> if the CN does not provide a <i>paging cause</i> in the RANAP <i>paging</i> message. An indication of which core network initiated the page: circuit-domain or packet-domain. If paging with IMSI, include this element. If paging with P-TMSI or TMSI, omit the element since the identity implicitly indicates the network initiating the page. <i>Paging cause</i> from the RANAP <i>paging</i> message. <Do we have enough message length to modify <i>paging request type 1</i> , <i>type 2</i> , and <i>type 3</i> ? If not, we may want to define a new <i>Iu-mode</i> paging message.>
9.1.23	Paging request type 2 Add the following to the <i>paging request type 2</i> : <ul style="list-style-type: none"> For mobile identities 1 through 3, an implicit indication of which network element initiated the page: CN or GERAN. For <i>mobile identity 3</i>, an indication of which core network initiated the page: circuit-domain or packet-domain. If paging with IMSI, include this element. If paging with P-TMSI or TMSI, omit the element since the identity implicitly indicates the network initiating the page. For mobile identities 1 through 3, <i>paging cause</i> from the RANAP <i>paging</i> message.
9.1.24	Paging request type 3 For all four mobile identities, add the following to the <i>paging request type 3</i> : <ul style="list-style-type: none"> An implicit indication of which network element initiated the page: CN or GERAN. <i>Paging cause</i> from the RANAP <i>paging</i> message.
10.5.2.23	P1 rest octets <i>Packet page indication i</i> applies when paging with G-RNTI. Delete the requirement that <i>Packet page indication i</i> be ignored if the mobile identity is not IMSI.
10.5.2.24	P2 rest octets <i>Packet page indication 3</i> applies when paging with G-RNTI. Delete the requirement that <i>Packet page indication 3</i> be ignored if the mobile identity is not IMSI.

	<p>Add a procedure for physical-channel reconfiguration.</p> <p>Add a <i>physical-channel reconfiguration</i> message based on the 25.331 message of the same name.</p> <p>Add a <i>physical-channel reconfiguration complete</i> message based on the 25.331 message of the same name.</p>
--	---

1

3.5 Changes to 44.060 (GERAN RLC/MAC)

2

Section	Description
6	Paging procedures Change title to <i>Paging procedures in A/Gb mode</i> .
6a	Add new section: <i>Paging procedures in Iu mode</i> .
11.2.10	Packet paging request Add the following information elements to the <i>packet paging request</i> : <ul style="list-style-type: none"> • An implicit indication of which network element initiated the page: CN or GERAN. The presence of <i>paging cause</i> indicates a CN-initiated page; the absence of <i>paging cause</i> indicates a GERAN-initiated page. This requires that GERAN fabricate a <i>paging cause</i> if the CN does not provide a <i>paging cause</i> in the RANAP <i>paging</i> message. • An indication of which core network initiated the page: circuit-domain or packet-domain. If paging with IMSI, include this element. If paging with P-TMSI or TMSI, omit the element since the identity implicitly indicates the network initiating the page. • <i>Paging cause</i> from the RANAP <i>paging</i> message. • G-RNTI as a <i>mobile identity</i>. Change the following: <ul style="list-style-type: none"> • Support paging with P-TSMI for RR connection establishment.
12	Information-element coding

3

3.6 Changes to 45.002 (L1 Multiplexing)

4

Section	Description
6.5.6	Determination of PCCCH_GROUP and PAGING_GROUP for MS in GPRS attached mode Specify that this section applies to mobile stations operating in <i>Iu mode</i> .

5

4. References

1. Cooper, Alan. *The Inmates are Running the Asylum – Why High-Tech Products Drive Us Crazy and How to Restore the Sanity*. Indianapolis: SAMS, 1999.
2. 3GPP TS 23.060. *3rd Generation Partnership Project; Technical Specification Group Services and System Aspects; General Packet Radio Service (GPRS); Service description; Stage 2*.
3. 3GPP TS 24.008. *3rd Generation Partnership Project; Technical Specification Group Core Network; Mobile radio interface layer 3 specification; Core Network Protocols - Stage 3*.
4. 3GPP TS 25.304. *3rd Generation Partnership Project; Technical Specification Group Radio Access Network; UE Procedures in Idle mode and Procedures for Cell Reselection in Connected Mode*.
5. 3GPP TS 25.331. *3rd Generation Partnership Project; Technical Specification Group Radio Access Network; RRC Protocol Specification*.
6. 3GPP TS 25.413. *3rd Generation Partnership Project; Technical Specification Group Radio Access Network; UTRAN Iu interface RANAP signalling*.
7. 3GPP TS 43.064. *3rd Generation Partnership Project; Technical Specification Group GERAN; Digital cellular telecommunications system (Phase 2+); General Packet Radio Service (GPRS); Overall description of the GPRS radio interface; Stage 2*.
8. 3GPP TS 44.018. *3rd Generation Partnership Project; Technical Specification Group GSM EDGE Radio Access Network; Mobile radio interface layer 3 specification; Radio Resource Control Protocol*.
9. 3GPP TS 44.060. *3rd Generation Partnership Project; Technical Specification Group GSM EDGE Radio Access Network; General Packet Radio Service (GPRS); Mobile Station (MS) – Base Station System (BSS) interface; Radio Link Control / Medium Access Control (RLC/MAC) protocol*.
10. 3GPP TS 45.002. *3rd Generation Partnership Project; Technical Specification Group GERAN; Digital cellular telecommunications system (Phase 2+); Multiplexing and multiple access on the radio path*.
11. G2-010063. *GERAN Iu paging procedures*. Helsinki: Ericsson, 25 Jun 01.
12. GAHW-010241. *Results of RLC/MAC drafting meeting*. Bellevue: GERAN Ad Hoc, 07 May 01.
13. GP-010679. *Analysis of GERAN Iu-mode paging scenarios*. Biarritz: Lucent, 02 Apr 01.
- ~~14. GP-010975. GERAN R5 offline session. Biarritz: [Alcatel, Ericsson, Nokia, Siemens], 02 Apr 01.~~

1 A. Network-operation modes

2 A.1 GPRS

3 GPRS operates in one of three modes:

- 4 • *Mode I* has a *Gs* interface between MSC and SGSN. For mobile stations attached to both domains, the MSC
5 sends circuit pages via the SGSN, *i.e.*, a BSSGP paging message on the *Gb* interface. The SGSN sends packet
6 pages directly to the BSS, *i.e.*, a BSSGP paging message on the *Gb* interface. The BSS pages the mobile station
7 via the following channel: PACCH if available, else PCCCH if available, else CCCH.
- 8 • *Mode II* has no *Gs* interface between MSC and SGSN. The MSC sends circuit pages directly to the BSS, *i.e.*, a
9 BSSAP paging message on the *A* interface. The SGSN sends circuit pages directly to the BSS, *i.e.*, a BSSGP
10 paging message on the *Gb* interface. The BSS pages the mobile station via the CCCH.
- 11 • *Mode III* has no *Gs* interface between MSC and SGSN. The MSC sends circuit pages directly to the BSS, *i.e.*, a
12 BSSAP paging message on the *A* interface. The SGSN sends circuit pages directly to the BSS, *i.e.*, a BSSGP
13 paging message on the *Gb* interface. The BSS sends circuit pages via the CCCH. It sends packet pages via the
14 PCCCH if available, else CCCH.

15 A.2 UMTS

16 UMTS operates in one of two modes:

- 17 • *Mode I* has a *Gs* interface between MSC and SGSN. For mobile stations attached to both domains, the MSC
18 sends circuit pages via the SGSN, *i.e.*, a RANAP paging message on the *Iu-ps* interface. The SGSN sends packet
19 pages directly to UTRAN, *i.e.*, a RANAP paging message on the *Iu-ps* interface.
- 20 • *Mode II* has no *Gs* interface between MSC and SGSN. The MSC sends circuit pages directly to UTRAN, *i.e.*, a
21 RANAP paging message on the *Iu-cs* interface. The SGSN sends packet pages directly to UTRAN, *i.e.*, a
22 RANAP paging message on the *Iu-ps* interface.

23 A.3 GERAN

24 This concept paper proposes that GERAN operate in any one of the following modes:

- 25 • *Mode I* has a *Gs* interface between MSC and SGSN. For mobile stations attached to both domains, the MSC
26 sends circuit pages via the SGSN, *i.e.*, a RANAP paging message on the *Iu-ps* interface. The SGSN sends packet
27 pages directly to the GERAN, *i.e.*, a RANAP paging message on the *Iu-ps* interface. GERAN pages the mobile
28 station via the following channel: PACCH if available, else PCCCH.
- 29 • *Mode II* has no *Gs* interface between MSC and SGSN. The MSC sends circuit pages directly to GERAN, *i.e.*, a
30 RANAP paging message on the *Iu-cs* interface. The SGSN sends packet pages directly to GERAN, *i.e.*, a
31 RANAP paging message on the *Iu-ps* interface. GERAN pages the mobile station via the following channel:
32 PACCH if available, else PCCCH if available, else CCCH.

33 <If the mobile station signals DRX parameters at circuit-domain attach and location-area update, why do we
34 need *mode I*?>

1 B. Paging equations

2 This annex describes several complicated methods of hashing mobile stations over available paging channels. Why
3 wasn't one simple method good enough? It's not the ETSI/3GPP way: never use a nail when you can specify
4 multidimensional impact-inserted flexible attachment functionality.

5 B.1 CCCH

6 3GPP TS 45.002 [10] specifies the information on which these equations are based.

7 B.1.1 Paging blocks per CCCH multiframe (N_m)

8 The following equation calculates the number of paging blocks per CCCH 51-multiframe.

$$9 \quad N_m = 9 - 6 * BS_CCCH_SDCCH_COMB - BS_AG_BLKS_RES$$

10 where:

11 N_m = number of paging blocks per CCCH 51-multiframe.

12 $BS_CCCH_SDCCH_COMB$ = SDCCH combined with CCCH (1) or not (0). Broadcast variable
13 ($CCCH_CONF$).

14 $BS_AG_BLKS_RES$ = number of blocks per common control channel not available for paging (0 to 7).
15 Broadcast variable.

16 B.1.2 Paging blocks per CCCH (N_c , M_c)

17 For GPRS-detached mobile stations, the following equation calculates the number of paging blocks per CCCH.

$$18 \quad N_c = BS_PA_MFRMS * N_m$$

19 where:

20 N_c = number of paging blocks per common control channel.

21 BS_PA_MFRMS = number of 51-multiframes between pages to the same mobile station (2 to 9).
22 Broadcast variable.

23 N_m = number of paging blocks per CCCH 51-multiframe.

24
25 For GPRS-attached mobile stations, the following equation calculates the number of packet paging blocks per CCCH. If
26 the CCCH does not support this type of paging, the preceding equation applies.

$$27 \quad M_c = 64 * N_m$$

28 where:

29 M_c = number of packet paging blocks per common control channel.

30 N_m = number of paging blocks per CCCH 51-multiframe.

1 B.1.3 Paging blocks per cell (N_t , M_t)

2 For GPRS-detached mobile stations, the following equation calculates the number of paging blocks for all common
3 control channels in a cell.

$$4 \quad N_t = BS_CC_CHANS * N_c$$

5 where:

6 N_t = total number of paging blocks per cell.

7 BS_CC_CHANS = number of common control channels (1 to 4). Broadcast variable
8 ($CCCH_CONF$).

9 N_c = number of paging blocks per common control channel.

10

11 For GPRS-attached mobile stations, the following equation calculates the number of packet paging blocks for all
12 common control channels in a cell. If the CCCH does not support this type of paging, the preceding equation applies.

$$13 \quad M_t = BS_CC_CHANS * M_c$$

14 where:

15 M_t = total number of packet paging blocks per cell.

16 BS_CC_CHANS = number of common control channels (1 to 4). Broadcast variable
17 ($CCCH_CONF$).

18 M_c = number of packet paging blocks per common control channel.

19 B.1.4 Monitored CCCH

20 The following equation calculates which CCCH a mobile station shall monitor.

$$21 \quad CCCH_GROUP = [(IMSI \bmod 1000) \bmod N_t] \text{ div } N_c$$

22 where:

23 $CCCH_GROUP$ = the common control channel to be monitored by the mobile station (0 to
24 $BS_CC_CHANS - 1$).

25 $IMSI$ = international mobile-subscriber identity.

26 N_t = total number of paging blocks per cell.

27 N_c = number of paging blocks per common control channel.

28 <Why does this hash function require three modulo or div operations instead of just one modulo operation based on the
29 number of CCCHs, i.e., $CCCH_GROUP = IMSI \bmod BS_CC_CHANS$?>

1 B.1.5 Monitored paging block on CCCH

2 For GPRS-detached mobile stations, the following equation calculates which paging block to monitor on the monitored
3 common control channel.

$$4 \quad PAGING_GROUP = [(IMSI \bmod 1000) \bmod N_t] \bmod N_c$$

5 where:

6 $PAGING_GROUP$ = the group of paging blocks the mobile station shall monitor.

7 $IMSI$ = international mobile-subscriber identity.

8 N_t = total number of paging blocks per cell.

9 N_c = number of paging blocks per common control channel.

10
11 For GPRS-attached mobile stations, the following equation calculates which paging block to monitor on the monitored
12 common control channel. If the CCCH does not support this type of paging, the preceding equation applies.

$$13 \quad PAGING_GROUP = \left(\begin{array}{l} [(IMSI \bmod 1000) \operatorname{div} N_t] * N_c + \\ (IMSI \bmod 1000) \bmod N_c + \\ \max[(m * M_c) \operatorname{div} SPLIT_PG_CYCLE, m] \end{array} \right) \bmod M_c$$

14 where:

15 $PAGING_GROUP$ = the group of paging blocks the mobile station shall monitor.

16 $IMSI$ = international mobile-subscriber identity.

17 N_t = total number of paging blocks per cell.

18 N_c = number of paging blocks per common control channel.

19 m = 0, 1 ... $\min(M_c, SPLIT_PG_CYCLE) - 1$.

20 M_c = number of packet paging blocks per common control channel.

21 $SPLIT_PG_CYCLE$ = the divisor for the period between pages to a mobile station, where the period is
22 expressed in M_c packet paging blocks, *e.g.*: if $SPLIT_PG_CYCLE = 1$, GERAN
23 will page the mobile station every M_c blocks (every 64 multiframes); if
24 $SPLIT_PG_CYCLE = 2$, GERAN will page the mobile station every $M_c/2$ blocks
25 (every 32 multiframes); if $SPLIT_PG_CYCLE = 64$, GERAN will page the
26 mobile station every $M_c/64$ blocks (every multiframe). Any time
27 $SPLIT_PG_CYCLE$ is set greater than or equal to M_c , GERAN will page the
28 mobile station in every packet paging block. GERAN and the mobile station
29 establish the value of $SPLIT_PG_CYCLE$ during GPRS attach.
30 $SPLIT_PG_CYCLE$ can take one of the following values: 1 to 64, 71, 72, 74 ...
31 352, 704. For the CCCH, $SPLIT_PG_CYCLE$ is not allowed to exceed 32.

1 B.1.6 Paging multiframe

2 For GPRS-detached mobile stations, when the following equation is true, the mobile station may be paged within the
3 multiframe containing FN .

$$4 \quad PAGING_GROUP \operatorname{div} N_m = (FN \operatorname{div} 51) \bmod(BS_PA_MFRMS)$$

5 where:

6 $PAGING_GROUP$ = the group of paging blocks the mobile station shall monitor.

7 N_m = number of paging blocks per CCCH 51-multiframe.

8 FN = frame number.

9 BS_PA_MFRMS = number of 51-multiframes between pages to the same mobile station (2 to 9).
10 Broadcast variable.

11

12 For GPRS-attached mobile stations, when the following equation is true, the mobile station may be paged within the
13 multiframe containing FN . If the CCCH does not support this type of paging, the preceding equation applies.

$$14 \quad PAGING_GROUP \operatorname{div} N_m = (FN \operatorname{div} 51) \bmod 64$$

15 where:

16 $PAGING_GROUP$ = the group of paging blocks the mobile station shall monitor.

17 N_m = number of paging blocks per CCCH 51-multiframe.

18 FN = frame number.

19 B.1.7 Paging-block index (i)

20 The following equation calculates the index to the paging block in which the mobile station may be paged, *i.e.*, a
21 calculated value of 0 indicates B0 (block 0).

$$22 \quad i = PAGING_GROUP \bmod N_m$$

23 where:

24 i = the index to the paging block within the 51-multiframe.

25 $PAGING_GROUP$ = the group of paging blocks the mobile station shall monitor.

26 N_m = number of paging blocks per CCCH 51-multiframe.

1 B.2 PCCCH

2 3GPP TS 45.002 [10] specifies the information on which these equations are based.

3 B.2.1 Paging blocks per PCCCH multiframe (N_{pm})

4 The following equation calculates the number of paging blocks per PCCCH 52-multiframe.

$$5 N_{pm} = 12 - BS_PAG_BLKS_RES - BS_PBCCH_BLKS$$

6 where:

7 N_{pm} = number of paging blocks per PCCCH 52-multiframe.

8 $BS_PAG_BLKS_RES$ = number of blocks per PCCCH not available for paging (0 to 12). Broadcast
9 variable.

10 BS_PBCCH_BLKS = number of blocks per 52-multiframe reserved for PBCCH. Broadcast variable.

11 B.2.2 Paging blocks per PCCCH (M_{pc})

12 The following equation calculates the number of paging blocks per PCCCH.

$$13 M_{pc} = 64 * N_{pm}$$

14 where:

15 M_{pc} = number of paging blocks per PCCCH.

16 N_{pm} = number of paging blocks per PCCCH 52-multiframe.

17 B.2.3 Paging blocks per cell (N_{pt})

18 The following equation calculates the number of paging blocks for all PCCCHs in a cell.

$$19 N_{pt} = BS_PCC_CHANS * M_{pc}$$

20 where:

21 N_{pt} = total number of paging blocks per cell.

22 BS_PCC_CHANS = number of PCCCHs (1 to 16). Broadcast variable.

23 M_{pc} = number of paging blocks per PCCCH.

24 B.2.4 Monitored PCCCH

25 The following equation calculates which PCCCH a mobile station shall monitor.

$$26 PCCCH_GROUP = (IMSI \bmod 1000) \bmod BS_PCC_CHANS$$

27 where:

28 $PCCCH_GROUP$ = the PCCCH to be monitored by the mobile station (0 to $BS_PCC_CHANS - 1$).

29 BS_PCC_CHANS = number of PCCCHs (1 to 16). Broadcast variable.

1 B.2.5 Monitored paging block on PCCCH

2 The following equation calculates which paging block a GPRS-attached mobile station shall monitor on the monitored
3 PCCCH.

$$4 \quad PAGING_GROUP = \left(\begin{array}{l} [(IMSI \bmod 1000) \operatorname{div} N_{pt}] * N_{pc} + \\ (IMSI \bmod 1000) \bmod N_{pc} + \\ \max[(m * M_{pc}) \operatorname{div} SPLIT_PG_CYCLE, m] \end{array} \right) \bmod M_{pc}$$

5 where:

- 6 $PAGING_GROUP$ = the group of packet paging blocks the mobile station shall monitor.
7 $IMSI$ = international mobile-subscriber identity.
8 N_{pt} = total number of packet paging blocks per cell.
9 N_{pc} = number of paging blocks per PCCCH.
10 m = 0, 1 ... $\min(M_{pc}, SPLIT_PG_CYCLE) - 1$.
11 M_{pc} = number of paging blocks per PCCCH.
12 $SPLIT_PG_CYCLE$ = the divisor for the period between pages to a mobile station, where the period is
13 expressed in M_{pc} packet paging blocks

14 B.2.6 Paging multiframe

15 When the following equation is true, the mobile station may be paged within the multiframe containing FN .

$$16 \quad PAGING_GROUP \operatorname{div} N_{pm} = (FN \operatorname{div} 52) \bmod 64$$

17 where:

- 18 $PAGING_GROUP$ = the group of paging blocks the mobile station shall monitor.
19 N_{pm} = number of paging blocks per PCCCH 52-multiframe.
20 FN = frame number.

21 B.2.7 Paging-block index (i)

22 The following equation calculates the index to the paging block in which the mobile station may be paged, *i.e.*, a
23 calculated value of 0 indicates B0 (block 0).

$$24 \quad i = PAGING_GROUP \bmod N_{pm}$$

25 where:

- 26 i = the index to the paging block within the 52-multiframe.
27 $PAGING_GROUP$ = the group of paging blocks the mobile station shall monitor.
28 N_{pm} = number of paging blocks per PCCCH 52-multiframe.

1 B.3 UTRAN

2 The following equation calculates the system frame number of the first frame of the paging block in which the mobile
3 station will be paged [4].

$$4 \quad P = [(IMSI \text{ div } K) \bmod(DRX \text{ div } PBP) * PBP] + [n * DRX] + Fo$$

5 where:

6 P = system frame number of the first frame of the paging block in which the mobile
7 station will be paged.

8 $IMSI$ = international mobile-subscriber identity.

9 K = number of paging channels.

10 DRX = DRX cycle length calculated as follows: $DRX = \max(2^k, PBP)$, where k is the
11 DRX cycle-length coefficient (an integer from 6 to 9) and PBP is the paging
12 block period specified below. Also, see the discussion in § B.4.

13 PBP = paging block period. $PBP = 1$ for frequency-division duplex.

14 n = non-negative integer.

15 Fo = frame offset.

16 B.4 DRX values for UTRAN

17 In *RRC Idle* mode, the UE shall use the following for *DRX*:

- 18 • The stored DRX cycle length for any CN domain to which the UE is attached. <Shouldn't the UE use the
19 shortest DRX cycle length?>

20 In *RRC Connected* mode, the UE shall use the shortest of the following for *DRX*:

- 21 • The UTRAN DRX cycle length calculated using the *UTRAN DRX cycle-length coefficient*. This coefficient
22 appears in several RRC messages, e.g., *Radio-Bearer Setup* and *Radio-Bearer Reconfiguration*.
- 23 • The stored DRX cycle length for any CN domain to which the UE is attached but not connected. <Shouldn't this
24 be the shortest stored DRX cycle length, not any stored value?>

25 The UE could be attached to two CN domains, circuit and packet, each having their own DRX cycle lengths. For the
26 circuit domain, the UE uses the circuit-domain *CN-domain-specific DRX cycle-length coefficient* broadcast in system
27 information. For the packet domain, the UE negotiates the DRX cycle length during attachment. If no DRX cycle length
28 has been negotiated, the UE uses the packet-domain *CN-domain-specific DRX cycle-length coefficient* broadcast in
29 system information.

1 C. States

2 This annex plagiarizes GP-010679 [13] and G2-010063 [11].

3 C.1 MM states

4 *Mobility management* applies to the circuit domain. One MM state machine resides in each mobile station. For each
5 mobile station, one MM state machine resides in the core network. The MM state machine has the following states:

- 6 • *MM-Detached.*
7 The core network cannot reach the mobile station for circuit services.
- 8 • *MM-Idle.*
9 The core network can reach the mobile station via paging. No *Iu-cs* or RRC connection exists.
- 10 • *MM-Connected.*
11 The core network supplies circuit services via a signalling connection between the core network and the mobile
12 station. A signalling connection comprises a RRC connection between MS and GERAN and an *Iu-cs* connection
13 between GERAN and CN.

14 C.2 PMM states

15 *Packet mobility management* applies to the packet domain. One PMM state machine resides in each mobile station. For
16 each mobile station, one PMM state machine resides in the core network. The PMM state machine has the following
17 states:

- 18 • *PMM-Detached.*
19 The core network cannot reach the mobile station for packet services.
- 20 • *PMM-Idle.*
21 The core network can reach the mobile station via paging. No *Iu-ps* or RRC connection exists.
- 22 • *PMM-Connected.*
23 The core network supplies packet services via a signalling connection between the core network and the mobile
24 station. A signalling connection comprises a RRC connection between MS and GERAN and an *Iu-ps* connection
25 between GERAN and CN.

26 C.3 RCC modes

27 *Radio-resource control* applies to the circuit and packet domains. One RRC state machine resides in each mobile
28 station. For each mobile station, one RRC state machine resides in the GERAN. The RRC state machine has two high-
29 level states — for some obscure reason, called modes:

- 30 • *RRC-Idle.*
31 No RRC connection exists between mobile station and GERAN. GERAN may be able to reach the mobile
32 station via paging. In this state (mode), both of the following will be true: MM is not in *MM-Connected state*;
33 PMM is not in *PMM-Connected state*.

34 Upon receipt of a RANAP *paging* message, GERAN pages the mobile station using a core-network identifier
35 (IMSI, TSML, or P-TMSI). Paging triggers the mobile station to establish an RRC connection and then send an
36 NAS (non-access stratum) paging response to the core network.

37 If the mobile station camps on a CCCH, RRC pages the mobile station. If the mobile station camps on PCCCH,
38 RRC requests that MAC page the mobile station.

- 39 • *RRC-Connected.*
40 A signalling connection exists between mobile station and GERAN. In this state (mode), one or more of the
41 following will be true: MM is in *MM-Connected state*; PMM is in *PMM-Connected state*.

1 C.4 RRC states

2 In *RRC Connected* mode, RRC is in one of the following states:

- 3 • *RRC-GRA_PCH.*

4 GERAN knows the mobile-station location to a GRA (GERAN registration area). RRC has allocated no physical
5 subchannels.

6 Upon receipt of a RANAP *paging* message, GERAN pages the mobile station using a GERAN identifier
7 (G-RNTI). Paging triggers the mobile station to perform a cell update and then send an NAS paging response to
8 the core network.

9 Upon receipt of a downlink PDU, GERAN pages the mobile station using a GERAN identifier (G-RNTI).
10 Paging triggers the mobile station to perform a cell update. Once GERAN knows which cell serves the mobile
11 station, it forwards the downlink PDU.

12 If the mobile station camps on a CCCH, RRC pages the mobile station. If the mobile station camps on PCCCH,
13 RRC requests that MAC page the mobile station.

- 14 • *RRC-Cell_Shared.*

15 GERAN knows the mobile-station location to the cell where the mobile station last performed a cell update.
16 RRC has allocated no dedicated physical subchannels. It has allocated zero (*MAC Idle* state), one (*MAC Shared*
17 state), or more (*MAC Shared* state) shared physical subchannels.

18 Upon receipt of a RANAP *paging* message, GERAN pages the mobile station using a GERAN identifier
19 (G-RNTI). Paging triggers the mobile station to send an NAS paging response to the core network. <Should the
20 mobile station perform a cell update? If so, why?>

21 Upon receipt of a downlink PDU, GERAN forwards the downlink PDU.

22 If the mobile station is in *MAC Shared* state, it monitors PACCH, and RRC performs paging. If the mobile
23 station is in *MAC Idle* state and it camps on a CCCH, RRC performs paging. If the mobile station is in *MAC Idle*
24 state and it camps on a PCCCH, RRC requests that MAC page.

- 25 • *RRC-Cell_Dedicated.*

26 GERAN knows the mobile-station location to a cell. RRC has allocated one or more dedicated physical
27 subchannels and zero or more shared physical subchannels.

28 Upon receipt of a RANAP *paging* message, GERAN pages the mobile station using a GERAN identifier
29 (G-RNTI). Paging triggers the mobile station to send an NAS paging response to the core network.

30 Upon receipt of a downlink PDU, GERAN forwards the downlink PDU.

31 RRC pages the mobile station using a dedicated control channel.