

Source: TSG CN WG 1
Title: TR 29.846v2.0.1; Multimedia Broadcast/Multicast Service (MBMS); CN1 procedure description- for approval
Agenda item: 9.8
Document for: APPROVAL

Presentation of Technical Report to TSG

Presentation to: TSG CN Meeting #25
Document for presentation: TR, Version 2.0.1
Presented for: Approval

Abstract of document:

The document is a temporary container for layer 3 UE to Core Network signalling flows for MBMS. The intention of this report is that when stable, the relevant content, including MBMS specific messages, Information Elements (IEs), and procedures will be moved into the appropriate Technical Specifications (TSes) such as 3GPP TS 24.008, 3GPP TS 24.007, 3GPP TS 44.065.

The document includes information applicable to network operators, service providers and manufacturers.

This TR will not be published.

Note: CN WG1 agreed at CN1 #35 to send this TR for approval, because the MBMS Work Item (WI) is considered to be mature enough (90%) and appropriate set of MBMS CRs against CN1 specifications is provided for approval at TSG CN #25.

Changes since last presentation to TSG Meeting #22:

- The MBMS Multicast deactivation procedure is introduced into TR 29.846 with two alternative solutions.
 - A chapter dealing with MBMS Security has been added.
 - Impacts on the Service Request procedure and the SNDCP entity have been identified and agreed solutions provided.
 - The error handling for the MBMS procedures is included within the existing TR and completed. The error handling mechanisms cover all identified scenarios for MBMS.
 - The exact format and type of the Information Elements specifically required or modification of existing ones for MBMS are complete (e.g. TMGI, MBMS protocol configuration options).
 - The agreed TR concludes that the existing Protocol Discriminator (PD) for GPRS Session Management (SM) messages will be used, as well as new messages shall be introduced for the MBMS Multicast service activation procedure, whereas reusing of existing GPRS SM messages is adopted for the MBMS Multicast service deactivation procedure.
-

Outstanding Issues:

- Recently, the SA WG3 (at meeting #34) has made the needed decision on MBMS Security to allow CN WG1 to progress the stage 3 work. Therefore, based on this, CN WG1 has decided at CN1 #35 that the MBMS Security work to be done by CN1 (i.e. the stage 3 on MBMS User authentication) will be specified into TS 24.109. This work on MBMS User authentication remains to be done, but it does not impact the TR 29.846.

Contentious Issues:

None.

3GPP TR 29.846 2.0.1 (2004-09)

Technical Report

3rd Generation Partnership Project; Technical Specification Group Core Networks; Multimedia Broadcast/Multicast Service (MBMS); CN1 procedure description (Release 6)



The present document has been developed within the 3rd Generation Partnership Project (3GPP™) and may be further elaborated for the purposes of 3GPP.

The present document has not been subject to any approval process by the 3GPP Organizational Partners and shall not be implemented. This Specification is provided for future development work within 3GPP only. The Organizational Partners accept no liability for any use of this Specification. Specifications and reports for implementation of the 3GPP™ system should be obtained via the 3GPP Organizational Partners' Publications Offices.

Keywords

MBMS, Broadcast, Multicast, Multimedia

3GPP

Postal address

3GPP support office address

650 Route des Lucioles - Sophia Antipolis
Valbonne - FRANCE
Tel.: +33 4 92 94 42 00 Fax: +33 4 93 65 47 16

Internet

<http://www.3gpp.org>

Copyright Notification

No part may be reproduced except as authorized by written permission.
The copyright and the foregoing restriction extend to reproduction in all media.

© 2004, 3GPP Organizational Partners (ARIB, ATIS, CCSA, ETSI, TTA, TTC).
All rights reserved.

Contents

Foreword.....	5
1 Scope	6
2 References	6
3 Definitions and abbreviations	6
3.1 Definitions	6
3.2 Abbreviations	7
4 Introduction	7
5 MBMS Session management.....	7
5.1 General	7
5.2 MBMS Session management states.....	7
5.2.1 MBMS Session management states in the UE	8
5.2.1.1 MBMS-INACTIVE.....	8
5.2.1.2 MBMS-ACTIVE-PENDING	8
5.2.1.3 MBMS-ACTIVE.....	8
5.2.2 MBMS Session management states on the network side	8
5.2.2.1 MBMS-INACTIVE.....	8
5.2.2.2 MBMS-ACTIVE-PENDING	8
5.2.2.3 MBMS-INACTIVE-PENDING	8
5.2.2.4 MBMS-ACTIVE.....	8
5.3 Multicast session management procedures.....	8
5.3.1 Multicast service activation	8
5.3.1.1 Overview	8
5.3.1.2 Layer 3 multicast session activation.....	10
5.3.1.2.1 MBMS context activation.....	10
5.3.1.3 Multicast session management messages for activation.....	12
5.3.1.3.1 Activate MBMS context request.....	12
5.3.1.3.2 Activate MBMS context accept.....	13
5.3.1.3.3 Activate MBMS context reject	13
5.3.1.3.4 Request MBMS context activation	13
5.3.1.3.5 Request MBMS context activation reject	14
5.3.2 Multicast service deactivation	14
5.3.2.1 Overview	14
5.3.2.2 Layer 3 multicast session deactivation	16
5.3.2.2.1 General	16
5.3.2.2.2 New procedure for MBMS multicast service deactivation	16
5.3.2.2.3 Reuse of PDP context deactivation for MBMS multicast service deactivation	16
5.3.2.3 MBMS protocol configuration options	17
5.3.2.4 Multicast session management messages for deactivation	17
5.3.2.4.1 Definition of new messages for MBMS multicast service deactivation	18
5.3.2.4.2 Reuse of PDP context deactivation messages for MBMS multicast service deactivation	18
5.4 MBMS Session Management Information Elements	20
5.4.1 Temporary Mobile Group Identity (TMGI).....	20
5.4.2 MBMS bearer capabilities	20
5.4.3 MBMS protocol configuration options	21
5.5 Enhancements to Session Management Information Elements	22
5.5.1 SM cause.....	22
5.6 Enhancements to Annex I (informative): GPRS specific cause values for session management and MBMS session management	23
5.6.1 Causes related to nature of request.....	23
5.6.2 Additional causes for MBMS session management.....	24
6 Service Continuity and Mobility	24
6.1 MBMS Service Request Procedure (Iu mode)	25
6.1.1 Overview.....	25

6.1.2	Layer3 Service Request procedure.....	26
6.1.2.1	Overview	26
6.1.2.2	Service Request procedure initiation.....	27
6.1.2.3	GMM common procedure initiation.....	27
6.1.2.4	Service request procedure accepted by the network.....	27
6.1.2.5	Service Request procedure not accepted by the network	27
6.1.2.6	Abnormal cases in the MS.....	27
6.1.2.7	Abnormal cases on the network side.....	28
6.1.3	Service Request Message.....	28
6.1.3.1	Service Type.....	28
7	MBMS Data Transfer	28
7.1	Service access points provided and used by SMDCP	29
7.2	SN-PDU Formats.....	30
8	Information storage.....	30
8.1	MBMS Context	30
8.2	MBMS Bearer Context.....	31
9	MBMS security.....	32
10	Interaction with other features	32
11	Agreed solutions.....	32
11.1	Impacts on 3GPP TS 24.008.....	32
Annex A:	Change history.....	33

Foreword

This Technical Report has been produced by the 3rd Generation Partnership Project (3GPP).

The contents of the present document are subject to continuing work within the TSG and may change following formal TSG approval. Should the TSG modify the contents of the present document, it will be re-released by the TSG with an identifying change of release date and an increase in version number as follows:

Version x.y.z

where:

- x the first digit:
 - 1 presented to TSG for information;
 - 2 presented to TSG for approval;
 - 3 or greater indicates TSG approved document under change control.
- y the second digit is incremented for all changes of substance, i.e. technical enhancements, corrections, updates, etc.
- z the third digit is incremented when editorial only changes have been incorporated in the document.

1 Scope

The present document discusses procedures required in the Core Network to support the Multimedia Broadcast/Multicast Service (MBMS) requirements that are outlined in 3GPP TS 22.146 [2] within the architectural solutions discussed in 3GPP TS 23.246 [3].

2 References

The following documents contain provisions which, through reference in this text, constitute provisions of the present document.

- References are either specific (identified by date of publication, edition number, version number, etc.) or non-specific.
- For a specific reference, subsequent revisions do not apply.
- For a non-specific reference, the latest version applies. In the case of a reference to a 3GPP document (including a GSM document), a non-specific reference implicitly refers to the latest version of that document *in the same Release as the present document*.

- [1] 3GPP TR 21.905: "Vocabulary for 3GPP Specifications".
- [2] 3GPP TS 22.146: "Multimedia Broadcast/Multicast Service; Stage 1".
- [3] 3GPP TS 23.246: "Multimedia Broadcast/Multicast Service (MBMS); Architecture and Functional Description".
- [4] 3GPP TS 24.007: "Mobile radio interface signalling layer 3; General aspects".
- [5] 3GPP TS 25.331: "Radio Resource Control (RRC) protocol specification".
- [6] 3GPP TS 33.246: "3G Security; Security of Multimedia Broadcast/Multicast Service (MBMS)".
- [7] IETF RFC 2236 (November 1997): "Internet Group Management Protocol, Version 2".
- [8] IETF RFC 2710 (October 1999): "Multicast Listener Discovery (MLD) for IPv6".
- [9] 3GPP TS 44.065: "Mobile station (MS) - Serving GPRS Support Node (SGSN); Subnetwork Dependent Convergence Protocol (SNDCP)".
- [10] 3GPP TS 24.008: "Mobile radio interface Layer 3 specification; Core network protocols; Stage 3".
- [11] 3GPP TS 29.061: "Interworking between the Public Land Mobile Network (PLMN) supporting packet based services and Packet Data Networks (PDN)".
- [12] ITU-T Recommendation E.212: "The international identification plan for mobile terminals and mobile users".
- [13] 3GPP TS 23.107: "Quality of Service (QoS) concept and architecture".

3 Definitions and abbreviations

3.1 Definitions

For the purposes of the present document, the following terms and definitions apply:

linked NSAPI: NSAPI of the PDP context used by the UE to carry IGMP/MLD signalling

MBMS context: 3GPP TR 29.846 uses this term to refer to the MBMS UE context as defined in 3GPP TS 23.246 [3].

MBMS Bearer context: 3GPP TR 29.846 uses this term as defined in 3GPP TS 23.246 [3].

MBMS NSAPI: used between an SGSN or RNC/BSC and a UE to identify the flow of MBMS data in the user plane

Mobile Station (MS): 3GPP TR 29.846 makes no distinction between MS and UE.

User Equipment (UE): 3GPP TR 29.846 makes no distinction between MS and UE.

3.2 Abbreviations

For the purpose of the present document, the abbreviations given in 3GPP TR 21.905 [1], 3GPP TS 22.146 [2] and the following apply:

TMGI Temporary Mobile Group Identity

4 Introduction

The MBMS (3GPP TS 22.146 [2]) is a point-to-multipoint service in which data is transmitted from a single source entity to multiple users. Transmitting the same data to multiple users allows network resources to be shared.

The MBMS offers two modes:

- **Broadcast Mode.**
- **Multicast Mode.**

5 MBMS Session management

Editor's Note: This clause will describe general information, as well as the state models, procedures and protocols used to activate and deactivate MBMS contexts between the UE and the Core Network and between core network elements. None of the text within this clause shall be transferred directly to any specification unless explicitly stated.

5.1 General

Editor's Note: This subclause will contain the general information describing the function of the MBMS session management. The text within this subclause should be readily transferable to clause 6 of 3GPP TS 24.008.

The function of the MBMS session management (MBMS-SM) is to support the MBMS service handling within the user terminal and network, which allows the user in the network to receive data from a specific MBMS source. The MBMS-SM comprises procedures for MBMS context activation and deactivation. MBMS-SM procedures for identified access can only be performed if a GMM context has been established between the UE and the network. If no GMM context has been established, the MM sublayer has to initiate the establishment of a GMM context by use of the GMM procedures as described in subclause 4 (see 3GPP TS 24.008 [10]). After GMM context establishment, MBMS-SM uses services offered by GMM (see 3GPP TS 24.007 [4]). Ongoing MBMS-SM procedures are suspended during GMM procedure execution.

In UMTS only, the MBMS protocol shall use integrity protected signalling. Integrity protection of all MBMS-SM signalling messages is the responsibility of lower layers. It is the network which activates integrity protection. This is done using the security mode control procedure (see 3GPP TS 25.331 [5]).

5.2 MBMS Session management states

Editor's Note: This subclause will describe the MBMS state models. The text within this subclause should be readily transferable to clause 6 of 3GPP TS 24.008.

5.2.1 MBMS Session management states in the UE

In this subclause, the possible states of an MBMS-SM entity in the UE are described.

5.2.1.1 MBMS-INACTIVE

This state indicates that no MBMS Context exists.

5.2.1.2 MBMS-ACTIVE-PENDING

This state exists when the UE has requested the network to initiate MBMS Context activation.

5.2.1.3 MBMS-ACTIVE

This state indicates that the MBMS Context is active.

5.2.2 MBMS Session management states on the network side

In this subclause, the possible states of an MBMS-SM entity on the network side are described.

5.2.2.1 MBMS-INACTIVE

This state indicates that the MBMS Context is not active.

5.2.2.2 MBMS-ACTIVE-PENDING

This state exists when the network has initiated MBMS Context activation.

5.2.2.3 MBMS-INACTIVE-PENDING

This state exists when the network has initiated MBMS Context deactivation.

5.2.2.4 MBMS-ACTIVE

This state indicates that the MBMS Context is active.

5.3 Multicast session management procedures

5.3.1 Multicast service activation

5.3.1.1 Overview

Figure 1 shows the multicast service activation signalling flow for MBMS. The activation procedure registers the user in the network to enable the reception of data from a specific multicast service. The procedure establishes the MBMS contexts in the UE, RNC, SGSN and GGSN for each activated multicast service.

New UE to CN messages requiring definition are shown in red within figure 1.

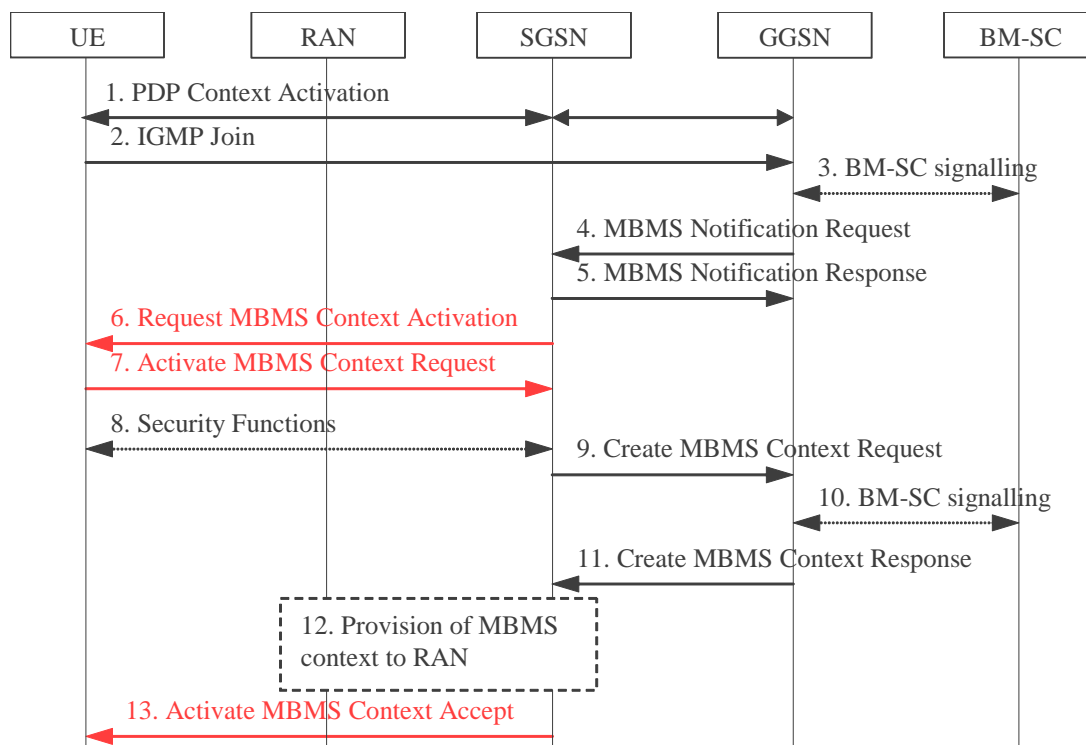

Figure 1. Activation of an MBMS Multicast service

1. The UE activates a default, typically best-effort PDP context if not already established. This can be a PDP context used for basic IP services like WAP or Internet access, or it might be the signalling PDP context used for IMS access.
2. The UE sends an IGMP (IPv4) or MLD (IPv6) Join message over the default PDP context to signal its interest in receiving a particular multicast service identified by an IP multicast address.
3. This signalling between GGSN and BM-SC is per user service access authorization.
4. The GGSN receives the IGMP Join request and sends an MBMS notification request to the SGSN.
5. The SGSN sends an MBMS Notification Response to the GGSN that sent the MBMS Notification Request. The MBMS Notification Response contains a cause that indicates whether or not the MBMS context activation will proceed. Upon reception of the response message with cause indicating unsuccessful operation or time-out of the MBMS Activation Timer in the GGSN, the GGSN may fallback to IP multicast access.
6. The SGSN sends a Request MBMS Context Activation to request the UE to activate an MBMS context. This message includes the IP multicast address earlier selected by the UE in the Join message, along with an Access Point Name (APN), which has been received from GGSN, the Linked NSAPI and a Transaction Identifier (TI). The TI is chosen by the SGSN and contains a value not used by any other activated PDP context and MBMS context for this UE.
7. The UE checks for the validity of the request to activate the service, and if valid, creates an MBMS context, and sends an Activate MBMS Context Request to the SGSN. This message includes the IP multicast address, which the UE wants to join/activate, an APN and the Supported MBMS bearer capabilities i.e. the maximum downlink bit rate the UE can handle. If the SGSN has the MBMS Bearer Context information for this MBMS bearer service, the SGSN will verify the UE's MBMS bearer capabilities. If the SGSN determines that the UE's MBMS bearer capabilities are less than the Required MBMS Bearer Capabilities, it rejects the request for activation of an MBMS context with an appropriate cause.
8. Security Functions may be performed in order to authenticate the UE for the MBMS Multicast service activation.
9. The SGSN creates an UE specific MBMS context and sends Create MBMS Context Requests to the GGSN.

Editor's note: It is for further study whether the SGSN performs a subscription check for the requested MBMS multicast service identified by the IP multicast address and APN or whether another network entity performs this check before the SGSN creates an UE specific MBMS context.

10. This signalling between GGSN and BM-SC is per user service access authorization and/or signalling of the GGSNs interest to receive the MBMS service data (per service and not per user). Also the GGSN or another network entity may perform a subscription check for the requested MBMS multicast service identified by the IP multicast address and APN.

The BM-SC allocates a Temporary Mobile Group Identify (TMGI) for group paging in MBMS. If no TMGI has been allocated for this MBMS bearer service, the BM-SC will allocate a new TMGI. This TMGI will be passed to the GGSN, SGSN and further to UE.

11. The GGSN creates an MBMS context for the UE and sends a Create MBMS Context Response to the SGSN.
12. The SGSN provides RAN with the MBMS context.
13. The SGSN verifies that the MBMS bearer capabilities supported by the UE are sufficient for the requested multicast service and sends an Activate MBMS Context Accept to the UE. This message includes the TMGI. If it was not possible to verify the UE's MBMS bearer capabilities in Step 7, the UE's MBMS bearer capabilities will be verified now. If the MBMS bearer capabilities supported by the UE are insufficient for the requested multicast service activation, the SGSN sends an Activate MBMS Context Reject to the UE including an appropriate cause value (i.e. "MS bearer capabilities insufficient for the service").

5.3.1.2 Layer 3 multicast session activation

Editor's Note: This subclause will describe the Layer 3 procedures for MBMS session activation including successful and failure scenarios. The text within this subclause should be readily transferable to clause 6 of 3GPP TS 24.008.

5.3.1.2.1 MBMS context activation

The purpose of this procedure is to establish an MBMS context in the UE and in the network for a specific IP Multicast Address using a specific NSAPI for MBMS user plane transmission. The UE shall only initiate the MBMS context activation when requested by the network, however the trigger for the activation request by the network is initiated by the UE at the application layer (see 3GPP TS 23.246 [3]).

5.3.1.2.1.1 Successful MBMS context activation

In order to request an MBMS context activation, the network sends a REQUEST MBMS CONTEXT ACTIVATION message to the UE, enters the state MBMS-ACTIVE-PENDING and starts timer T3385. The message shall contain the IP multicast address, the APN and the Linked NSAPI.

Upon receipt of a REQUEST MBMS CONTEXT ACTIVATION message, the UE shall validate the message by verifying the NSAPI given in the Linked NSAPI IE to be one of the active PDP context(s), and send an ACTIVATE MBMS CONTEXT REQUEST, enter state MBMS ACTIVE-PENDING and start timer T3380. The message shall contain an IP multicast address and an APN, which shall be the same as the IP multicast address and the APN requested by the network in the REQUEST MBMS CONTEXT ACTIVATION message. Furthermore, the UE shall include the Supported MBMS bearer capabilities, i.e. the maximum downlink bit rate the UE can handle.

Upon receipt of the ACTIVATE MBMS CONTEXT REQUEST message, the network shall stop timer T3385. If the network accepts the request, it shall reply with an ACTIVATE MBMS CONTEXT ACCEPT message.

Upon receipt of the message ACTIVATE MBMS CONTEXT ACCEPT the MS shall stop timer T3380 and shall enter the state MBMS-ACTIVE.

5.3.1.2.1.2 Unsuccessful MBMS context activation requested by the UE

Upon receipt of an ACTIVATE MBMS CONTEXT REQUEST message the network may reject the MS initiated MBMS context activation by sending an ACTIVATE MBMS CONTEXT REJECT message to the MS. The sender of the message shall include the same TI as included in the ACTIVATE MBMS CONTEXT REQUEST and an additional cause code that typically indicates one of the following causes:

- # 8: Operator Determined Barring;
- # 24: MS bearer capabilities insufficient for the service;
- # 26: insufficient resources;
- # 27: missing or unknown APN;
- # 29: user authentication failed;
- # 30: activation rejected by GGSN;
- # 31: activation rejected, unspecified;
- # 32: service option not supported;
- # 33: requested service option not subscribed;
- # 34: service option temporarily out of order;
- # 35: NSAPI already used. The network shall not send this cause code (see note); or
- # 95 to 111: protocol errors.

NOTE: Pre-R99 network may send this cause code.

Upon receipt of an ACTIVATE MBMS CONTEXT REJECT message, the MS shall stop timer T3380 and enter/remain in state MBMS-INACTIVE.

5.3.1.2.1.3 Unsuccessful MBMS context activation requested by the network

Upon receipt of the REQUEST MBMS CONTEXT ACTIVATION message, the UE may reject the network requested MBMS context activation by sending the REQUEST MBMS CONTEXT ACTIVATION REJECT message to the network. The sender of the message shall include the same TI as included in the REQUEST MBMS CONTEXT ACTIVATION and an additional cause code that typically indicates one of the following causes:

- # 26: insufficient resources;
- # 31: activation rejected, unspecified;
- # 40: feature not supported; or
- # 95 to 111: protocol errors.

The network shall stop timer T3385 and enter state MBMS-INACTIVE.

5.3.1.2.1.4 Abnormal cases

The following abnormal cases can be identified:

- a) Expiry of timers in the mobile station: On the first expiry of the timer T3380, the MS shall resend the ACTIVATE MBMS CONTEXT REQUEST and shall reset and restart timer T3380. This retransmission is repeated four times, i.e. on the fifth expiry of timer T3380, the MS shall release all resources possibly allocated for this invocation and shall abort the procedure; no automatic MBMS context activation re-attempt shall be performed.

- b) Expiry of timers on the network side: On the first expiry of the timer T3385, the network shall resend the message REQUEST MBMS CONTEXT ACTIVATION and shall reset and restart timer T3385. This retransmission is repeated four times, i.e. on the fifth expiry of timer T3385, the network shall release possibly allocated resources for this activation and shall abort the procedure.
- c) MBMS context activation request for an already activated MBMS context (on the mobile station side): If the MS receives a REQUEST MBMS CONTEXT ACTIVATION message with the same combination of APN and IP multicast address (i.e. PDP type and PDP address) as an already activated MBMS context, the MS shall deactivate the existing MBMS context locally without notification to the network and proceed with the requested MBMS context activation.
- d) MBMS context activation request for an already activated MBMS context (on the network side): If the network receives an ACTIVATE MBMS CONTEXT REQUEST message with the same combination of APN and IP multicast address (i.e. PDP type and PDP address) as an already activated MBMS context, the network shall deactivate the existing MBMS context locally without notification to the MS and proceed with the requested MBMS context activation.

5.3.1.3 Multicast session management messages for activation

Editor's Note: This subclause will describe the Layer 3 message formats and IE. Where ever possible, any IE types referenced here shall re-use existing IE formats from TS 24.008. If new IEs need to be defined, they must be included within this subclause. The text within this subclause should be readily transferable to clause 9 of 3GPP TS 24.008. The text in this subclause is intended to be copied directly to 3GPP TS 24.008 when it is fully agreed.

5.3.1.3.1 Activate MBMS context request

This message is sent by the MS to the network as an explicit response to a REQUEST MBMS CONTEXT ACTIVATION message

Message type: activate MBMS context REQUEST

Significance: global

Direction: MS to network

Table 5.3.1.3.1: ACTIVATE MBMS CONTEXT REQUEST message content

IEI	Information element	Type/Reference	Presence	Format	Length
	Protocol discriminator	Protocol discriminator	M	V	1/2
	Transaction identifier	Transaction identifier	M	V	1/2 to 3/2
	Activate MBMS context request message identity	Message type	M	V	1
	Requested MBMS NSAPI	Network service access point identifier	M	V	1
	Requested LLC SAPI	LLC service access point identifier	M	V	1
	Supported MBMS bearer capabilities	MBMS bearer capabilities	M	LV	2 to 3
	Requested multicast address	Packet data protocol address	M	LV	3 to 19
28	Access point name	Access point name	M	LV	2 to 101
XX	MBMS protocol configuration options	MBMS protocol configuration options 5.4.3	O	TLV	3 to 253

NOTE: The MBMS NSAPI will be used when UTRAN chooses a point-to-point MBMS bearer for the transfer of MBMS data in the user plane.

5.3.1.3.2 Activate MBMS context accept

This message is sent by the network to the MS to acknowledge activation of an MBMS context.

Message type: activate MBMS context ACCEPT

Significance: global

Direction: network to MS

Table 5.1.3.2: ACTIVATE MBMS CONTEXT ACCEPT message content

IEI	Information element	Type/Reference	Presence	Format	Length
	Protocol discriminator	Protocol discriminator	M	V	1/2
	Transaction identifier	Transaction identifier	M	V	1/2 to 3/2
	Activate MBMS context accept message identity	Message type	M	V	1
	Temporary Mobile Group Identity	Temporary Mobile Group Identity	M	LV	4 to 7
	Negotiated LLC SAPI	LLC service access point identifier	M	V	1
XX	MBMS protocol configuration options	MBMS protocol configuration options 5.4.3	O	TLV	3 to 253

5.3.1.3.3 Activate MBMS context reject

This message is sent by the network to the MS to reject activation of a MBMS context.

Message type: activate MBMS context reject

Significance: global

Direction: network to MS

Table 5.3.1.3.3: ACTIVATE MBMS CONTEXT REJECT message content

IEI	Information element	Type/Reference	Presence	Format	Length
	Protocol discriminator	Protocol discriminator	M	V	1/2
	Transaction identifier	Transaction identifier	M	V	1/2 to 3/2
	Activate MBMS context reject message identity	Message type	M	V	1
	SM cause	SM Cause	M	V	1
XX	MBMS protocol configuration options	MBMS protocol configuration options 5.4.3	O	TLV	3 to 253

5.3.1.3.4 Request MBMS context activation

This message is sent by the network to the MS to initiate activation of an MBMS context.

Message type: request MBMS context activation

Significance: global

Direction: network to MS

Table 5.3.1.3.4: REQUEST MBMS CONTEXT ACTIVATION message content

IEI	Information Element	Type/Reference	Presence	Format	Length
	Protocol discriminator	Protocol discriminator	M	V	1/2
	Transaction identifier	Transaction identifier	M	V	1/2 to 3/2
	Request MBMS context activation message identity	Message type	M	V	1
	Linked NSAPI	Network service access point identifier	M	V	1
	Offered Multicast address	Packet data protocol address	M	LV	3 to 19
28	Access point name	Access point name	M	LV	2 to 101
XX	MBMS protocol configuration options	MBMS protocol configuration options 5.4.3	O	TLV	3 to 253

5.3.1.3.4.1 Linked NSAPI

This IE is included in the message to allow the UE to associate the MBMS context with the PDP context over which the IGMP/MLD join message was sent.

5.3.1.3.5 Request MBMS context activation reject

This message is sent by the MS to the network to reject initiation of an MBMS context activation.

Message type: request MBMS context ACTIVATION reject

Significance: global

Direction: MS to network

Table 5.3.1.3.5: REQUEST MBMS CONTEXT ACTIVATION REJECT message content

IEI	Information Element	Type/Reference	Presence	Format	Length
	Protocol discriminator	Protocol discriminator	M	V	1/2
	Transaction identifier	Transaction identifier	M	V	1/2 to 3/2
	Request MBMS context act. reject message identity	Message type	M	V	1
	SM cause	SM cause	M	V	1
XX	MBMS protocol configuration options	MBMS protocol configuration options 5.4.3	O	TLV	3 to 253

5.3.2 Multicast service deactivation

5.3.2.1 Overview

Figure 2 shows the multicast service deactivation signalling flow for MBMS. The deactivation procedure removes the MBMS context from the UE and the network (i.e. SGSN and GGSN) for a specific multicast service.

New messages requiring definition are shown in red within figure 2.

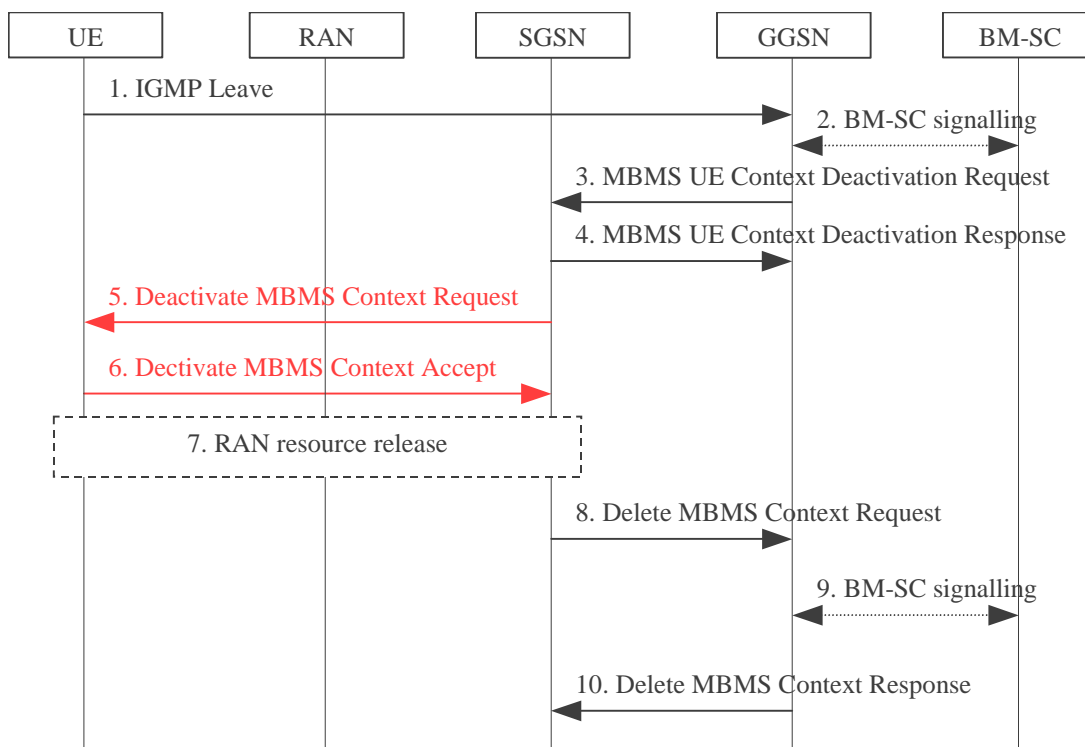

Figure 2: Deactivation of an MBMS Multicast service.

1. The UE sends an IGMP (IPv4) or MLD (IPv6) Leave message over the default PDP context to leave a particular multicast service identified by an IP multicast address.
2. This signalling between GGSN and BM-SC is performed in order to indicate that the UE is requesting to leave the multicast service identified by the IP multicast address.

NOTE 1: The exact nature of the signalling between GGSN and BM-SC is specified in 3GPP TS 29.061 [11].

3. The GGSN sends an MBMS Context Deactivation Request (IP multicast address, APN, IMSI) to the SGSN. The IP multicast address, APN and IMSI together identify the MBMS context to be deleted by the SGSN. The APN is received in step 2.
4. The SGSN acknowledges reception of the MBMS Context Deactivation Request by sending an MBMS Context Deactivation Response to the GGSN.
5. Upon reception of the MBMS Context Deactivation Request or for other reasons (e.g. due to a change in the roaming restrictions for the user) the SGSN sends a Deactivate MBMS Context Request (TI) to the UE. The TI identifies the MBMS context to be deleted by the UE.
6. The UE deletes the MBMS context and sends a Deactivate MBMS Context Accept (TI) to the SGSN.
7. If dedicated radio resources are currently assigned to the UE for the reception of the MBMS data, the RAN releases these radio resources.

Editor's note: The detailed procedures and conditions to release the radio resources are for further study depending on ongoing work in RAN groups.

8. Upon reception of the Deactivate MBMS Context Accept or for other reasons (e.g. due to missing periodic updates) the SGSN sends a Delete MBMS Context Request (NSAPI) to the GGSN that holds the MBMS context.
9. This signalling between GGSN and BM-SC is mainly performed to delete the MBMS context in the GGSN and BM-SC.

NOTE 2: The exact nature of the signalling between GGSN and BM-SC is specified in 3GPP TS 29.061 [11].

10. The GGSN confirms the deactivation of the MBMS context to the SGSN by sending a Delete MBMS Context Response to the SGSN, which then deletes the MBMS context.

5.3.2.2 Layer 3 multicast session deactivation

Editor's Note: This subclause will describe the Layer 3 procedures for MBMS session deactivation including successful and failure scenarios. The text within this subclause should be readily transferable to clause 6 of 3GPP TS 24.008.

5.3.2.2.1 General

The purpose of this procedure is to deactivate an existing MBMS context in the UE and the network. The UE shall only initiate the MBMS context deactivation when requested by the network, however the trigger for the deactivation request by the network may be initiated by the UE at application layer or by the network, see 3GPP TS 23.246 [3].

After a successful MBMS context deactivation, the associated TI value shall be released in both the UE and the network.

5.3.2.2.2 New procedure for MBMS multicast service deactivation

Editor's Note: This subclause describes one solution for the MBMS multicast service deactivation procedure. This alternative was not selected. Another alternative is found in the subclause 5.3.2.2.3.

5.3.2.2.2.1 MBMS context deactivation

In order to request an MBMS context deactivation, the network sends a DEACTIVATE MBMS CONTEXT REQUEST message to the UE, enters the state MBMS-INACTIVE-PENDING and starts timer T3395. The message contains the transaction identifier (TI) in use for the MBMS context to be deactivated and a cause code that typically indicates one of the following causes:

- # 36: regular deactivation;
- # 38: network failure;
- # 47: multicast group membership time-out.

Editor's Note: The indication of the IGMP group membership time-out or MLD multicast listener time-out requires defining a new cause value in the SM cause IE (See 3GPP TS 24.008 subclause 10.5.6.6). Other possible new cause values may be identified in the future.

The UE shall reply with a DEACTIVATE MBMS CONTEXT ACCEPT message and enter the state MBMS-INACTIVE. Upon receipt of the DEACTIVATE MBMS CONTEXT ACCEPT message, the network shall stop the timer T3395 and enter the state MBMS-INACTIVE.

5.3.2.2.2.2 Abnormal cases

The following abnormal cases can be identified:

- a) Expiry of timers:

On the first expiry of the timer T3395, the network shall resend the message DEACTIVATE MBMS CONTEXT REQUEST and shall reset and restart the timer T3395. This retransmission is repeated, i.e. on the fifth expiry of the timer T3395, the network shall erase the MBMS context related data for that UE.

5.3.2.2.3 Reuse of PDP context deactivation for MBMS multicast service deactivation

Editor's Note: This subclause describes one solution for the MBMS multicast service deactivation procedure. This alternative was selected. Another alternative is found in the subclause 5.3.2.2.2.

5.3.2.2.3.1 PDP and MBMS context deactivation initiated by the network

In order to deactivate either a PDP context or an MBMS context, the network sends a DEACTIVATE PDP CONTEXT REQUEST message to the MS and starts timer T3395. The message contains the transaction identifier in use for the PDP or MBMS context to be deactivated and a cause code that typically indicates one of the following causes:

- # 8: Operator Determined Barring;
- # 25: LLC or SMDCP failure;
- # 36: regular deactivation;
- # 38: network failure;
- # 39: reactivation requested;
- # 47: multicast group membership time-out.

Editor's Note: Some of the cause values are applicable to only either the PDP or MBMS context or both. This limitation requires to be put in the annex I of 3GPP TS 24.008 that lists the cause values for session management. Furthermore, the indication of the IGMP group membership time-out or MLD multicast listener time-out requires defining a new cause value in the SM cause IE. (See 3GPP TS 24.008 subclause 10.5.6.6). Other possible new cause values for MBMS context may be identified in the future.

The MS shall reply with a DEACTIVATE PDP CONTEXT ACCEPT message and enter the state PDP-INACTIVE or MBMS-INACTIVE depending what type of deactivation was requested by the network. Upon receipt of the DEACTIVATE PDP CONTEXT ACCEPT message, the network shall stop the timer T3395 and enter the state PDP-INACTIVE or MBMS-INACTIVE depending on whether the deactivation acceptance message indicates either a PDP context or an MBMS context.

In GSM and for PDP context, both the MS and the network shall initiate local release of the logical link if it is not used by another PDP context.

In UMTS and for PDP context, the network shall initiate the release of Radio Access Bearer associated with this PDP context.

5.3.2.2.3.2 Abnormal cases

Editor's Note: This subclause describes only the abnormal cases applicable to the MBMS context. This is done in order to show only changes needed because of MBMS context introduction.

The following abnormal cases can be identified:

a) Expiry of timers:

On the first expiry of timer T3395, the network shall resent the message DEACTIVATE PDP CONTEXT REQUEST and shall reset and restart timer T3395. This retransmission is repeated four times, i.e. on the fifth expiry of timer T3395, the network shall erase either the PDP context related data, if the deactivation indicates a PDP context or the MBMS context related data, if the deactivation indicates an MBMS context.

5.3.2.3 MBMS protocol configuration options

The MS and the GGSN may communicate parameters related to the MBMS bearer by means of the MBMS protocol configuration options information element when activating or deactivating an MBMS context. Such parameters can e.g. be used to convey information between the MS and the GGSN.

The MBMS protocol configuration options information element is transparent to the SGSN.

5.3.2.4 Multicast session management messages for deactivation

Editor's Note: This subclause will describe the Layer 3 message formats and IE. Where ever possible, any IE types referenced here shall re-use existing IE formats from 3GPP TS 24.008. If new IEs need to be defined, they must be included within this subclause. The text within this subclause should be readily transferable to clause 9 of 3GPP TS 24.008.

5.3.2.4.1 Definition of new messages for MBMS multicast service deactivation

Editor's Note: This subclause describes one solution for the MBMS multicast service deactivation messages. Another alternative is found in the subclause 5.3.2.4.2.

5.3.2.4.1.1 Deactivate MBMS context request

This message is sent by the network to the MS to request the deactivation of an active MBMS context.

Message type: DEACTIVATE MBMS CONTEXT REQUEST

Significance: global

Direction: network to MS

Table 5.3.2.4.1.1: DEACTIVATE MBMS CONTEXT REQUEST message content

IEI	Information Element	Type/	Presence	Format	Length
	Protocol discriminator	Protocol discriminator	M	V	1/2
	Transaction identifier	Transaction identifier	M	V	1/2 to 3/2
	Deactivate MBMS context request message identity	Message type	M	V	1
	SM cause	SM cause	M	V	1
XX	MBMS protocol configuration options	MBMS protocol configuration options 5.4.3	O	TLV	3 to 253

5.3.2.4.1.2 Deactivate MBMS context accept

This message is sent by the MS to the network to acknowledge deactivation of the MBMS context requested in the corresponding *Deactivate MBMS context request* message. See subclause 5.3.2.4.1.1.

Message type: Deactivate MBMS context accept

Significance: global

Direction: MS to network

Table 5.3.2.4.1.2: DEACTIVATE MBMS CONTEXT ACCEPT message content

IEI	Information Element	Type/Reference	Presence	Format	Length
	Protocol discriminator	Protocol discriminator	M	V	1/2
	Transaction identifier	Transaction identifier	M	V	1/2 to 3/2
	Deactivate MBMS context accept message identity	Message type	M	V	1
XX	MBMS protocol configuration options	MBMS protocol configuration options 5.4.3	O	TLV	3 to 253

5.3.2.4.2 Reuse of PDP context deactivation messages for MBMS multicast service deactivation

Editor's Note: This subclause describes one solution for the MBMS multicast service deactivation messages. Another alternative is found in the subclause 5.3.2.4.1.

5.3.2.4.2.1 Deactivate PDP context request

This message is sent to request deactivation of an active either PDP context or MBMS context.

Message type: deactivate PDP context request

Significance: global

Direction: both

Table 5.3.2.4.2.1: DEACTIVATE PDP CONTEXT REQUEST message content

IEI	Information Element	Type/Reference	Presence	Format	Length
	Protocol discriminator	Protocol discriminator	M	V	1/2
	Transaction identifier	Transaction identifier	M	V	1/2 to 3/2
	Deactivate PDP context request message identity	Message type	M	V	1
	SM cause	SM cause	M	V	1
9	Tear down indicator	Tear down indicator	O	TV	1
27	Protocol configuration options	Protocol configuration options	O	TLV	3 -to253
XX	MBMS protocol configuration options	MBMS protocol configuration options 5.4.3	O	TLV	3 to 253

5.3.2.4.2.1.1 Tear down indicator

This IE is included in the message in order to indicate whether only the PDP context associated with this specific TI or all active PDP contexts sharing the same PDP address as the PDP context associated with this specific TI shall be deactivated. If the IE is received for an MBMS context, it shall be ignored by the receiver.

5.3.2.4.2.1.2 Protocol configuration options

This IE is included in the message when the MS or the network wishes to transmit (protocol) data (e.g. configuration parameters, error codes or messages/events) to the peer entity for a PDP context. If the IE is received for an MBMS context, it shall be ignored by the receiver.

5.3.2.4.2.1.3 MBMS protocol configuration options

This IE is included in the message when the MS or the network wishes to transmit MBMS bearer related (protocol) data (e.g. configuration parameters, error codes or messages/events) to the peer entity for an MBMS context. If the IE is received for a PDP context, it shall be ignored by the receiver.

5.3.2.4.2.2 Deactivate PDP context accept

This message is sent to acknowledge deactivation of either the PDP context requested in the corresponding *Deactivate PDP context request* message or the MBMS context requested in the corresponding *Deactivate MBMS context request* message. See subclause 5.3.2.4.2.1.

Message type: deactivate PDP context accept

Significance: global

Direction: both

Table 5.3.2.4.2.2: DEACTIVATE PDP CONTEXT ACCEPT message content

IEI	Information Element	Type/Reference	Presence	Format	Length
	Protocol discriminator	Protocol discriminator	M	V	1/2
	Transaction identifier	Transaction identifier	M	V	1/2 to 3/2
	Deactivate PDP context accept message identity	Message type	M	V	1
27	Protocol configuration options	Protocol configuration options	O	TLV	3 to 253
XX	MBMS protocol configuration options	MBMS protocol configuration options 5.4.3	O	TLV	3 to 253

5.3.2.4.2.2.1 Protocol configuration options

This IE is included in the message when the MS or the network wishes to transmit (protocol) data (e.g. configuration parameters, error codes or messages/events) to the peer entity for a PDP context. If the IE is received for an MBMS context, it shall be ignored by the receiver.

5.3.2.4.2.2.2 MBMS protocol configuration options

This IE is included in the message when the MS or the network wishes to transmit MBMS bearer related (protocol) data (e.g. configuration parameters, error codes or messages/events) to the peer entity for an MBMS context. If the IE is received for a PDP context, it shall be ignored by the receiver.

5.4 MBMS Session Management Information Elements

5.4.1 Temporary Mobile Group Identity (TMGI)

The purpose of the TMGI element is for group paging in MBMS.

The TMGI information element is a type 4 information element with a minimum length of 5 octets and a maximum length of 8 octets. If octet 6 is included, then octets 7 and 8 shall also be included.

The content of the TMGI element is shown in figure 5.4.1.

8	7	6	5	4	3	2	1	
Temporary Mobile Group Identity IEI								Octet 1
Length of Temporary Mobile Group Identity contents								Octet 2
MBMS Service ID								Octet 3 Octet 4 Octet 5
MCC digit 2				MCC digit 1				Octet 6
MNC digit 3				MNC digit 3				Octet 7
MNC digit 2				MNC digit 1				Octet 8

Figure 5.4.1: TMGI information element

Table 5.4.1: TMGI information element

MBMS Service ID (octet 3, 4 and 5)

In the MBMS Service ID field bit 8 of octet 3 is the most significant bit and bit 1 of octet 5 the least significant bit. The coding of the MBMS Service ID is the responsibility of each administration. Coding using full hexadecimal representation may be used. The MBMS Service ID consists of 3 octets.

MCC, Mobile country code (octet 6, octet 7 bits 1 to 4)

The MCC field is coded as in ITU-T Recommendation E.212 [12], annex A.

MNC, Mobile network code (octet 7 bits 5 to 8, octet 8)

The coding of this field is the responsibility of each administration but BCD coding shall be used. The MNC shall consist of 2 or 3 digits. If a network operator decides to use only two digits in the MNC, bits 5 to 8 of octet 7 shall be coded as "1111".

5.4.2 MBMS bearer capabilities

The purpose of the *MBMS bearer capabilities* information element is to indicate the maximum bit rate for downlink supported by the MS for an MBMS context.

NOTE: The information element indicates the static physical capabilities of the MS, independent of the radio access (UMTS or GSM), the radio conditions, or other CS or PS services possibly activated by the MS.

The *MBMS bearer capabilities* is a type 4 information element with a maximum length of 4 octets.

The *MBMS bearer capabilities* information element is coded as shown in figure 5.4.2.

8	7	6	5	4	3	2	1	
MBMS bearer capabilities IEI								Octet 1
Length of MBMS bearer capabilities IE								Octet 2
Maximum bit rate for downlink								Octet 3
Maximum bit rate for downlink (extended)								Octet 4

Figure 5.4.2: MBMS bearer capabilities information element

Table 5.4.2: MBMS bearer capabilities information element

<p>Maximum bit rate for downlink, octet 3 (see 3GPP TS 23.107 [13]).</p> <p>The coding is identical to that of the maximum bit rate for downlink, octet 9, in the <i>Quality of service</i> information element (see subclause 10.5.6.5).</p> <p>If the sending entity wants to indicate a maximum bit rate for downlink higher than 8640 kbps, it shall set octet 3 to "11111110", i.e. 8640 kbps, and shall encode the value for the maximum bit rate in octet 4.</p> <p>Maximum bit rate for downlink (extended), octet 4.</p> <p>The coding is identical to that of the maximum bit rate for downlink (extended), octet 15, in the <i>Quality of service</i> information element (see subclause 10.5.6.5).</p>
--

5.4.3 MBMS protocol configuration options

The purpose of the *MBMS protocol configuration options* information element is to:

- transfer protocol options associated with the bearer level of an MBMS context activation; and
- transfer additional MBMS bearer related (protocol) data (e.g. configuration parameters, error codes or messages/events).

The *MBMS protocol configuration options* is a type 4 information element with a minimum length of 3 octets and a maximum length of 253 octets.

The *MBMS protocol configuration options* information element is coded as shown in figure 5.4.3 and table 5.4.3.

8	7	6	5	4	3	2	1	
MBMS protocol configuration options IEI								octet 1
Length of MBMS protocol config. options contents								octet 2
0	0	0	0	0	0	0	0	octet 3
Spare								

Figure 5.4.3: MBMS protocol configuration options information element

Table 5.4.3: MBMS protocol configuration options information element

<p>Bits 1 to 8 of octet 3 are spare and shall be coded as "0".</p> <p>NOTE: The reason for defining the information element is to have a transparent mechanism in the SGSN available from the introduction of MBMS. This will ensure that MS - GGSN communication is possible if new MBMS bearer service related parameters are defined.</p>
--

5.5 Enhancements to Session Management Information Elements

5.5.1 SM cause

Editor's Note: Two new cause values need to be added to the SM cause IE in 3GPP TS 24.008, subclause 10.5.6.6. Other possible new cause values for MBMS context may be identified in the future.

The purpose of the *SM cause* information element is to indicate the reason why a session management request is rejected.

The *SM cause* is a type 3 information element with 2 octets length.

The *SM cause* information element is coded as shown in figure 5.5.1 and table 5.5.1.

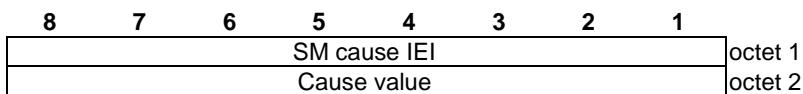

Figure 5.5.1: *SM cause* information element

Table 5.5.1: SM cause information element

Cause value (octet 2)	
Bits	
8	7 6 5 4 3 2 1
00001000	Operator Determined Barring
00011000	MBMS bearer capabilities insufficient for the service
00011001	LLC or SNDCP failure (GSM only)
00011010	Insufficient resources
00011011	Missing or unknown APN
00011100	Unknown PDP address or PDP type
00011101	User Authentication failed
00011110	Activation rejected by GGSN
00011111	Activation rejected, unspecified
00100000	Service option not supported
00100001	Requested service option not subscribed
00100010	Service option temporarily out of order
00100011	NSAPI already used (not sent)
00100100	Regular deactivation
00100101	QoS not accepted
00100110	Network failure
00100111	Reactivation required
00101000	Feature not supported
00101001	Semantic error in the TFT operation
00101010	Syntactical error in the TFT operation
00101011	Unknown PDP context
00101110	PDP context without TFT already activated
00101111	Multicast group membership time-out
00101100	Semantic errors in packet filter(s)
00101101	Syntactical errors in packet filter(s)
01010001	Invalid transaction identifier value
01011111	Semantically incorrect message
01100000	Invalid mandatory information
01100001	Message type non-existent or not implemented
01100010	Message type not compatible with the protocol state
01100011	Information element non-existent or not implemented
01100100	Conditional IE error
01100101	Message not compatible with the protocol state
01101111	Protocol error, unspecified
01110000	APN restriction value incompatible with active PDP context

Any other value received by the mobile station shall be treated as 0010 0010, "Service option temporarily out of order". Any other value received by the network shall be treated as 0110 1111, "Protocol error, unspecified".

NOTE: The listed cause values are defined in annex I.

5.6 Enhancements to Annex I (informative): GPRS specific cause values for session management and MBMS session management

5.6.1 Causes related to nature of request

Editor's Note: The following changes need to be made to clause I.1 of 3GPP TS 24.008.

Cause value = 26 Insufficient resources

This cause code is used by the MS or by the network to indicate that a PDP context activation request, secondary PDP context activation request, or PDP context modification request, or MBMS context activation request cannot be accepted due to insufficient resources.

Cause value = 36 Regular PDP context deactivation

This cause code is used to indicate a regular MS or network initiated PDP context deactivation or a regular network initiated MBMS context deactivation.

Cause value = 38 Network failure

This cause code is used by the network to indicate that the PDP context deactivation or MBMS context deactivation is caused by an error situation in the network.

Cause value = 39 Reactivation requested

This cause code is used by the network to request a PDP context reactivation or MBMS context reactivation after a GGSN restart.

Cause value = 40 Feature not supported

This cause code is used by the MS to indicate that the PDP context activation or MBMS context activation initiated by the network is not supported by the MS.

Cause value = 112 APN restriction value incompatible with active PDP context.

This cause code is used by the network to indicate that a requested primary PDP context or MBMS context has an APN restriction value that is not allowed in combination with a currently active PDP context. Restriction values are defined in 3GPP TS 23.060, subclause 15.4.

Editor's Note: The following subclause needs to be added to 3GPP TS 24.008 as clause I.3.

5.6.2 Additional causes for MBMS session management

Cause value = 24 MBMS bearer capabilities insufficient for the service

This cause code is used by the network to indicate that an MBMS context activation request was rejected by the network, because the MBMS bearer capabilities are insufficient for the service.

Cause value = 47 Multicast group membership time-out

This cause code is used by the network to indicate that the MBMS context is deactivated because the timer supervising the IGMP group membership interval (see RFC 2236 [7], section 8.4) or the MLD multicast listener interval (see RFC 2710 [8], section 7.4) expired.

6 Service Continuity and Mobility

Editor's Note: This subclause will describe the procedure for maintaining continuity of service during mobility related events.

The CN is required to support mobility functions for MBMS in order to support service continuity. It is recognized that some data loss may occur when a mobile moves (e.g. between SGSNs) and MBMS applications are required to be able to deal with such data loss. This is reflected in 3GPP TS 23.246 [3].

The RAN is responsible for dealing with mobility and selection of radio bearers transparently to the CN. Only when a UE moves between RNCs supported by different SGSNs does the CN need to become involved. In this case there are two possible scenarios:

1. The MBMS bearer context needs to be set up in this new SGSN as no other UEs under this SGSN are currently receiving this service; hence CN signalling is required (via GTP) to create the MBMS bearer context.
2. The MBMS bearer context already exists for this service at the SGSN; hence no MBMS bearer contexts need to be established in the CN. There may be a need to establish the bearer context in the RNC, dependent on whether there are UEs under that particular RNC receiving the service or not.

In either case the CN will use existing GTP signalling to establish the MBMS bearer contexts using SRNS relocation message (modified to support MBMS) if the change of SGSN is due to SRNS relocation, and/or new GTP messages to update the contexts in the SGSNs and the GGSN. Dependent on the network configuration, the UE may be required to set up a signalling connection via the service request procedure.

For UEs with ongoing MBMS services, MBMS contexts need to be transferred between SGSNs during inter-SGSN Routing Area Update procedures and inter-SGSN SRNS relocation procedures.

Editor's Note: The impact to a UE operating in A/Gb mode is for further study.

6.1 MBMS Service Request Procedure (Iu mode)

6.1.1 Overview

For MBMS, when in Iu mode RAN wants to count the number of users that are interested in a specific MBMS service present in a cell, it will request a percentage of the interested UEs to transit to PMM-CONNECTED state. The MBMS Service Request procedure is used by a UE in PMM-IDLE state to move to PMM-CONNECTED state.

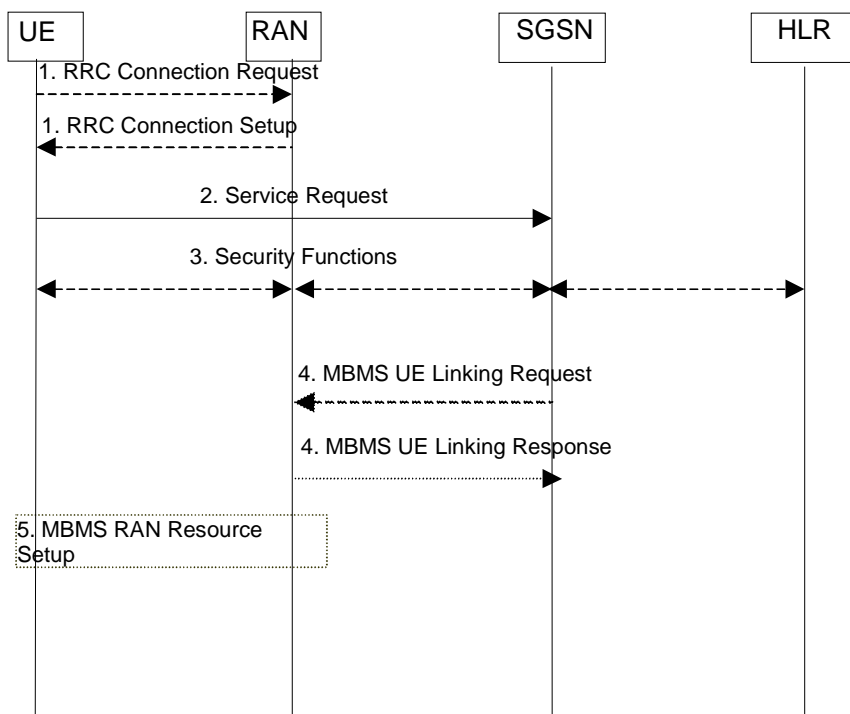

Figure 3: MBMS Service Request procedure

1. The UE establishes an RRC connection, if none exists.
2. The UE sends a Service Request message to the SGSN if required to do so by the RAN after a MBMS Session Starts.
3. The SGSN may perform the security functions. In order to complete the Service Request procedure the SGSN initiates a security mode control procedure.
4. The SGSN provides RAN with the MBMS context(s) via MBMS UE Linking procedure.
5. The RAN establishes the necessary radio resources for the transfer of MBMS data to the interested UEs.

6.1.2 Layer3 Service Request procedure

Editor's Note: This subclause will describe the Layer 3 procedures for MBMS service request including successful and failure scenarios. The text within this subclause should be readily transferable to clause 4 of 3GPP TS 24.008. In addition, we may need further procedures at CN side to support the MBMS Service Request procedure (FFS).

6.1.2.1 Overview

The purpose of this procedure is to transfer the PMM mode from PMM-IDLE to PMM-CONNECTED mode, and/or to assign radio access bearers if PDP contexts are activated without radio access bearers assigned. In the latter case, the PMM mode may be PMM-IDLE mode or may alternatively be the PMM-CONNECTED mode if the MS requires radio access bearer re-establishment. This procedure is used for:

- the initiation of CM layer service (e.g. SM or SMS) procedure from the MS in PMM-IDLE mode;
- the network to transfer down link signalling;
- uplink (in PMM-IDLE or PMM CONNECTED) and downlink (only in PMM-IDLE) user data;
- counting the number of mobile stations in a cell which are interested in a specific MBMS service.

For downlink transfer of signalling or user data in PMM-IDLE mode, the trigger is given from the network by the paging request procedure, which is out of scope of the present document.

For pending downlink user data in PMM-CONNECTED mode, the re-establishment of radio access bearers for all active PDP contexts is done without paging.

For counting the number of mobile stations in PMM-IDLE mode interested in a specific MBMS service, the trigger is given from the network by the MBMS notification procedure, which is out of scope of the present document.

Service type can take either of the following values, "signalling", "data", "paging response" or "MBMS notification response". Each of the values shall be selected according to the criteria to initiate the Service request procedure.

The criteria to invoke the Service request procedure are when:

- a) the MS has any signalling messages except GMM messages (e.g. for SM or SMS) to be sent to the network in PMM-IDLE mode (i.e., no secure PS signalling connection has been established). In this case, the service type shall be set to "signalling".
- b) the MS, either in PMM-IDLE or PMM-CONNECTED mode, has pending user data to be sent and no radio access bearer is established for the corresponding PDP context. The procedure is initiated by an indication from the lower layers (see 3GPP TS 24.007 [4]). In this case, the service type shall be set to "data". If in PMM-CONNECTED mode, a Service Request with service type "data" was already accepted by the network the MS shall not issue a second Service Request with service type "data" unless the PMM-IDLE state is entered again.
- c) the MS receives a paging request for PS domain from the network in PMM-IDLE mode.
- d) the MS is in PMM-IDLE mode, receives an MBMS notification for a multicast service for which the MS has activated an MBMS context, and is prompted by the contents of the notification to establish a PS signalling connection (see 3GPP TS 25.331 [5]). In this case, the service type shall be set to "MBMS notification response".

After completion of a Service request procedure but before re-establishment of radio access bearer, if the PDP context status information element is included, then the network shall deactivate all those PDP contexts locally (without peer to peer signalling between the MS and the network), which are not in SM state PDP-INACTIVE on network side but are indicated by the MS as being in state PDP-INACTIVE.

After completion of a Service request procedure, the pending service is resumed and uses then the connection established by the procedure. If the service type is indicating "data", then the radio access bearers for all activated PDP contexts are re-established by the network, except for those activated PDP contexts having maximum bit rate value set to 0 kbit/s for both uplink and downlink. The re-establishment of radio access bearers for those PDP contexts is specified in subclause 6.1.3.3 (see 3GPP TS 24.008 [10]).

The selective re-assignment capability is not supported for the simplicity of the function.

6.1.2.2 Service Request procedure initiation

The MS initiates the Service request procedure by sending a SERVICE REQUEST message. The timer T3317 shall be started after the SERVICE REQUEST message has been sent and state GMM-SERVICE-REQUEST-INITIATED is entered. The message SERVICE REQUEST shall contain the P-TMSI and the Service type shall indicate either data, signalling, paging response or MBMS notification response.

6.1.2.3 GMM common procedure initiation

Editor's Note: No deviations from the corresponding subclause in 3GPP TS 24.008 have been identified so far.

6.1.2.4 Service request procedure accepted by the network

Editor's Note: No deviations from the corresponding subclause in 3GPP TS 24.008 have been identified so far.

6.1.2.5 Service Request procedure not accepted by the network

Editor's Note: No deviations from the corresponding subclause in 3GPP TS 24.008 have been identified so far.

6.1.2.6 Abnormal cases in the MS

The following abnormal cases can be identified:

a) Access barred because of access class control

The Service request procedure shall not be started. The MS stays in the current serving cell and applies normal cell reselection process. The Service request procedure may be started by CM layer if it is still necessary, i.e. when access is granted or because of a cell change.

b) Lower layer failure before the security mode control procedure is completed, SERVICE ACCEPT or SERVICE REJECT message is received

The procedure shall be aborted.

c) T3317 expired

The MS shall enter GMM-REGISTERED state.

If the MS is in PMM-IDLE mode then the procedure shall be aborted and the MS shall initiate a PS signalling connection release.

If the MS is in PMM-CONNECTED mode, then the procedure shall be aborted.

d) SERVICE REJECT received, other causes than those treated in subclause 4.7.13.4 (see 3GPP TS 24.008).

The procedure shall be aborted.

e) Routing area update procedure is triggered

If a cell change into a new routing area occurs and the necessity of routing area update procedure is determined before the security mode control procedure is completed, a SERVICE ACCEPT or SERVICE REJECT message has been received, the Service request procedure shall be aborted and the routing area updating procedure is started immediately. Follow-on request pending may be indicated in the ROUTING AREA UPDATE REQUEST for the service, which was the trigger of the aborted Service request procedure, to restart the pending service itself or the Service Request procedure after the completion of the routing area updating procedure. If the service type of the aborted SERVICE REQUEST was indicating "data", then the routing area update procedure may be followed by a re-initiated Service request procedure indicating "data", if it is still necessary. If the service type was indicating "MBMS notification response", the Service request procedure shall be aborted.

f) Power off

If the MS is in state GMM-SERVICE-REQUEST-INITIATED at power off, the GPRS detach procedure shall be performed.

g) Procedure collision

If the MS receives a DETACH REQUEST message from the network in state GMM-SERVICE-REQUEST-INITIATED, the GPRS detach procedure shall be progressed and the Service request procedure shall be aborted. If the cause IE, in the DETACH REQUEST message, indicated a "reattach request", the GPRS attach procedure shall be performed.

6.1.2.7 Abnormal cases on the network side

Editor's Note: No deviations from the corresponding subclause in 3GPP TS 24.008 have been identified so far.

6.1.3 Service Request Message

This message has the same structure as existing SERVICE REQUEST message in 3GPP TS 24.008.

6.1.3.1 Service Type

*Editor's Note: This subclause describes the Layer 3 IE Service Type. The text within this subclause should be readily transferable to clause 9 of 3GPP TS 24.008. The purpose of the *service type* information element is to specify the purpose of the Service request procedure.*

The *service type* is a type 1 information element.

The *service type* information element is coded as shown in figure 6.1.3.1 and table 6.1.3.1.

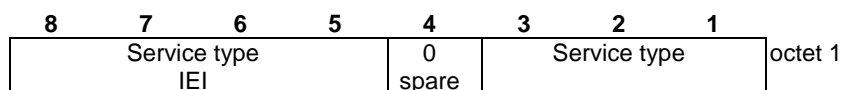

Figure 6.1.3.1: Service type information element

Table 6.1.3.1: Service type information element

Service type value (octet 1)			
Bits			
3	2	1	
0	0	0	Signalling
0	0	1	Data
0	1	0	Paging Response
0	1	1	MBMS Notification Response
All other values are reserved.			

7 MBMS Data Transfer

Editor's Note: This clause will describe the procedures and protocols used to notify the user of MBMS data transfer, the establishment of data bearers, and transfer data in the Core Network.

In MBMS, once the user has requested to join a service the MBMS context is established in the CN and RAN. The GTP User plane, Iu interface and radio bearers are not established at this time. These bearers are set up when an indication is received from the BM-SC that the session is about to start.

The start indication will be supported by new messages on the Gmb, Gn, Gb and Iu interfaces. When the SGSN receives the message that indicates a session is about to start, it will make a request to establish the radio resources for all UEs that have requested the service, including taking responsibility for the paging of the interested UEs.

In Iu mode, the RAN sets up appropriate point-to-point or point-to-multipoint links for the distribution of MBMS data dependent on the number of UEs in each cell. Dependent on the network configuration, a certain number of UEs may be required to set up signalling connections via the service request procedure. A new encoding for Service Type is introduced to explicitly indicate "MBMS notification response" as the service type. This is described in the subclause 6.1.

Editor's Note: The impact to a UE operating in A/Gb mode is for further study.

7.1 Service access points provided and used by SNDSCP

Editor's Note: This subclause will describe the use of the MBMS NSAPI in the figure showing the SNDSCP structure. The figure within this subclause should be readily transferable to subclause 5.1 of 3GPP TS 44.065 [9] when it is fully agreed.

This subclause explains the service primitives used for communication between the SNDSCP layer and other layers. See also 3GPP TS 24.007 [4] to get an overall picture of the service primitives. Figure 4 illustrates the service access points through which the primitives are carried out.

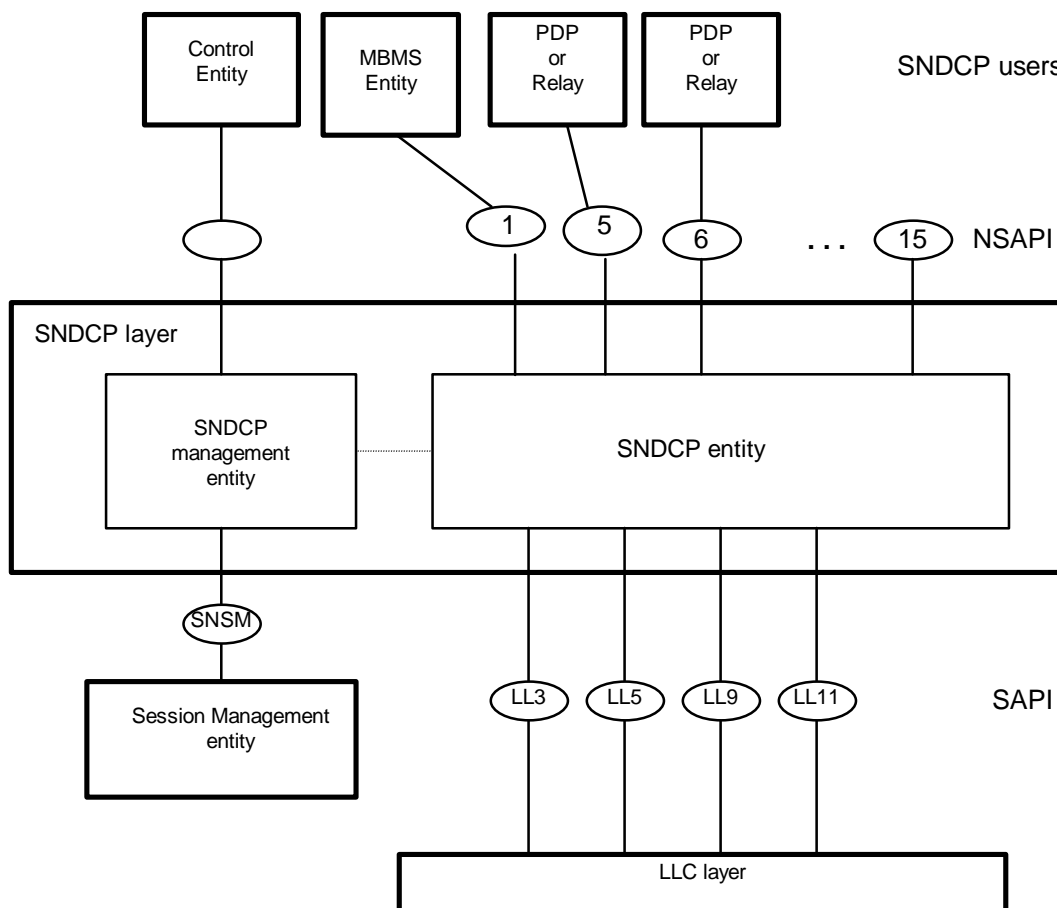

Figure 4: Service Access Points provided and used by SNDSCP

7.2 SN-PDU Formats

Editor's Note: This subclause will describe the definition MBMS NSAPI. The text within this subclause should be readily transferable to subclause 7.2 of 3GPP TS 44.065 [9] when it is fully agreed.

Each SN-PDU shall contain an integral number of octets, and shall comprise a header part and a data part. An SN-PDU shall contain data from a single N-PDU only. Two different SN-PDU formats are defined. The SN-DATA PDU shall be used for acknowledged data transfer and SN-UNITDATA PDU for unacknowledged data transfer.

Bit	8	7	6	5	4	3	2	1
Oct 1	X	F	T	M	NSAPI			
2	DCOMP				PCOMP			
3	N-PDU number - acknowledged mode							
...	Data segment							
N								

Figure 5: SN-DATA PDU format

Bit	8	7	6	5	4	3	2	1
Oct 1	X	F	T	M	NSAPI			
2	DCOMP				PCOMP			
3	Segment number				N-PDU number - unacknowledged mode			
4	N-PDU number - unacknowledged mode (continued)							
...	Data segment							
N								

Figure 6: SN-UNITDATA PDU format

NSAPI:

- 0 Escape mechanism for future extensions.
- 1 Point-to-Multipoint Multicast (PTM-M) information for Multimedia Broadcast/Multicast Service (MBMS).
- 2 to 4 Reserved for future use.
- 5 to 15 Dynamically allocated NSAPI value (see subclause 6.1 of 3GPP TS 44.065 [9]).

The SGSN shall ignore any uplink data traffic of SN-PDUs with an NSAPI value = 1.

SN-PDU with an unallocated NSAPI value shall be ignored by the receiving SNDCP entity without error notification.

8 Information storage

Editor's Note: This clause will highlight additional Information storage requirements for MBMS.

8.1 MBMS Context

In MBMS it is necessary for the SGSN and GGSN to maintain data for each UE that has requested to join each Multicast service the MBMS context. This context information is passed from one SGSN to another during inter-SGSN Routing Area Update procedure and Inter SGSN SRNS relocation procedures. The MBMS Context information includes:

- IP Multicast Address.
- APN.
- TMGI.

- Linked NSAPI.
- TI.
- MBMS NSAPI.

This context information is derived from the MBMS Context Activation procedure.

Hence the CN is required to store this information as described in 3GPP TS 23.246 [3], but it has no impact on the SM procedures over and above those defined for the MBMS context activation procedure.

8.2 MBMS Bearer Context

The MBMS Bearer Context contains all information describing a particular bearer of a Multicast service and is created in each node involved in the delivery of the MBMS data.

An MBMS Bearer Context is created in the SGSN and GGSN when the first MBMS Context is created in the node or when a downstream node requests it. An MBMS Bearer Context, once created, can be in one of two states (Standby or Active) reflecting the activity status of the corresponding MBMS bearer.

'Active' reflects the state of an MBMS Bearer Context in which user plane resources are established in the network for the transfer of MBMS data. This state is maintained as long as there is data pending for a corresponding MBMS session.

'Standby' reflects the state of an MBMS Bearer Context in which no user plane resources are established in the network for the transfer of MBMS data. This state is maintained as long as there is data pending for a corresponding MBMS session.

The MBMS Bearer Context information can include, dependent on state:

- IP Multicast Address.
- APN.
- TMGI.
- State.
- QoS (if Active state).
- MBMS Service Area (if Active state).
- List of Downstream Nodes.
- Number of UEs per RA list (SGSN only, Optional).
- Required MBMS Bearer Capabilities.
- Number of UEs.

Editor's note: "Number of UEs" may be used to determine when the last UE leaves the node and/or for content-provider charging. The meaning and relevance of this parameter for the RAN are for further study.

Editor's note: "Number of UEs per RA list" lists the number of UEs for each RA, which contains at least one UE that has joined the MBMS service. Its format is FFS.

9 MBMS security

MBMS security stage 2 is specified in 3GPP TS 33.246 [6].

Editor's Note: Security for MBMS stage 2 is specified by SA3 in TS 33.246 [6]. However, it is envisaged that there will also be impact on specifications within the CN1 responsibility area. The changes due to MBMS security will either be specified in this subclause, or where other modifications are already proposed with that proposal. The changes will be described in enough detail to allow CR's to be written to the appropriate CN1 specifications in a later stage.

MBMS data can be protected by encryption. This encryption will be applied end-to-end between the BM-SC and the UEs. Cipherring at the RAN or core network level is not required. Therefore:

- in Iu mode, the SGSN will not perform a RANAP security mode control procedure for MBMS bearers at the Iu interface;
- in A/Gb mode, the SGSN will not apply cipherring to LLC frames to be transmitted via MBMS point-to-multipoint bearers. For LLC frames to be transmitted during a point-to-point repair service, the SGSN will apply cipherring according to the generic operator policy for user data transfer.

10 Interaction with other features

Editor's note: This clause will describe the impacts on any existing features.

11 Agreed solutions

Editor's Note: This clause will describe agreements reached and the specifications affected. The changes will be described in enough detail to allow CRs to be written to the appropriate specifications.

11.1 Impacts on 3GPP TS 24.008

For MBMS Session Management (SM) the existing Protocol Discriminator (PD) for GPRS SM messages will be used, i.e. no new PD for MBMS will be introduced. New SM messages for MBMS context activation related messages will be defined.

Annex A: Change history

Change history							
Date	TSG #	TSG Doc.	CR	Rev	Subject/Comment	Old	New
2003-03					Tdoc N1-0300277 agreed at CN3#27 in Dublin	0.0.1	0.1.0
2003-10					Changes after CN1#32 with agreed tdocs, N1-031654, N1-031655, N1-031726, N1-031657, N1-031658, N1-031659, N1-031660	0.2.0	0.3.0
2004-01					Changes after CN1#32bis with agreed tdoc, N1-040101	1.0.0	1.1.0
2004-02					Changes after CN1#33 with agreed tdocs, N1-040421, N1-040422, N1-040467, N1-040473	1.1.0	1.2.0
2004-04					Changes after CN1#33bis with agreed tdocs, N1-040581, N1-040634, N1-040685, N1-040697, N1-040698, N1-040699, N1-040700, N1-040701, N1-040702	1.2.0	1.3.0
2004-04					Version 1.3.1 produced because of missed items during implementation of N1-040702 and N1-040700.	1.3.0	1.3.1
2004-05					Changes after CN1#34 with agreed tdocs, N1-041028, N1-041029, N1-041031, N1-041032, N1-041033, N1-041052 and N1-041085	1.3.1	1.4.0
2004-06					Changes after CN1#34bis with agreed tdocs, N1-041169, N1-041190, N1-041273, N1-041275, N1-041294	1.4.0	1.5.0
2004-08					Changes after CN1#35 with agreed tdocs, N1-041507, N1-041573, N1-041643.	1.5.0	1.6.0
2004-08					Version 2.0.0 is identical to version 1.6.0 for presentation for approval to plenary (TSG CN #25).	1.6.0	2.0.0
2004-09		NP-040368			Version 2.0.1 contains only editorial changes compared to v2.0.0	2.0.0	2.0.1