



INTERNATIONAL TELECOMMUNICATION UNION

**TELECOMMUNICATION
STANDARDIZATION SECTOR**

STUDY PERIOD 2001-2004

NP-040325
SSG – LS 2 – E

Original: English

Question(s): Q.2/SSG San Diego, 9 - 11 August 2004
Source: Q.2/SSG Rapporteur
Title: Technical Report on mobility management

LIAISON STATEMENT

TO: 3GPP TSG-CN, TSG-SA
3GPP2 TSG-C, TSG-X
IEEE 802.21

APPROVAL: Q.2/SSG Rapporteurs Meeting, August 2004

FOR: Comment

DEADLINE: 10 December 2004

CONTACT: Farrokh Khatibi
QUALCOMM Inc.
5775 Morehouse Dr.
San Diego, CA 92121-1714

Tel: +1 858 658-3716
Fax: +1 858 658-2114
E-mail: fkhatibi@qualcomm.com

With the convergence of fixed and wireless networks, the convergence of telecommunication and information technologies, and the foreseen ultimate migration to interoperable and harmonized network architectures, there is an industry requirement to provide global roaming and seamless mobility for the users of different access technologies and/or different operators so that they can enjoy seamless services while moving within or across networks.

SSG is the lead Study Group on IMT 2000 and beyond and for Mobility Management. Towards that goal, Q.2/SSG has developed the attached Supplement that identifies the mobility management requirements for Systems Beyond IMT-2000, based on ITU-T Recommendations Q.1702 and Q.1703 and ITU-R Recommendation M.1645. It also includes review and analysis of a number of mobility management protocols according to the identified requirements.

Attached please find the latest version of Q.TRMMR. As this Supplement is scheduled to be submitted for approval at the December 2004 meeting of the SSG, you are kindly requested to review the content to ensure that it is technically correct and it is in line with your Mobility Management specifications. Please share with us any comments that you may have.

We look forward to continued mutual cooperation.



"LS to

3GPPs-attachment.dc

Attention: Some or all of the material attached to this liaison statement may be subject to ITU copyright. In such a case this will be indicated in the individual document.
Such a copyright does not prevent the use of the material for its intended purpose, but it prevents the reproduction of all or part of it in a publication without the authorization of ITU.

**Supplement XX to ITU-T Q-series Recommendations
Technical Report Q.TRMMR
for Systems Beyond IMT-2000**

Summary

This Supplement identifies the mobility management requirements for Systems Beyond IMT-2000, based on ITU-T Recommendations Q.1702 [7] and Q.1703 [8] and ITU-R Recommendation M.1645 [23]. A number of mobility management protocols are reviewed and analysed according to the identified requirements.

Keywords

Systems Beyond IMT-2000, mobility, mobility management, mobility management requirements, mobility management protocol

© ITU 2004

*"All rights reserved. No part of this publication may be reproduced, by any means whatsoever,
without the prior written permission of ITU."*

1	Scope	4
2	References	4
3	Definitions	4
4	Abbreviations	5
5	Introduction	8
6	Considerations for Mobility Management in SBI2K	10
6.1	<i>Envisaged Network Environments for SBI2K</i>	10
6.2	<i>Interworking Scenario for SBI2K Network</i>	11
6.3	<i>Level of Mobility Support</i>	12
6.4	<i>Basic Mobility Management Functionalities</i>	12
6.5	<i>Classification of Mobility Management</i>	13
6.5.1	MM types	13
6.5.2	Considerations on MM application from International Mobile Telecommunications-2000 (I2K) Family Member perspectives	14
6.6	<i>Consideration of 3GPP and 3GPP2 Activities for Inter-Network MM Supports</i>	15
7	Requirements for Mobility Management Protocols for SBI2K	16
7.1	<i>Independence from Network Access Technologies</i>	16
7.2	<i>Harmonization with the IP-based Core Networks</i>	16
7.3	<i>Separation of Control and Transport Functions</i>	16
7.4	<i>Provision of a Location Management Function</i>	16
7.5	<i>Provision of Mechanisms for Identification of Users/Terminals</i>	17
7.6	<i>Interworking with Established AAA and Security schemes</i>	17
7.7	<i>Provision of Mechanisms for Context Transfer</i>	17
7.8	<i>Effective Interworking among different level of MM Protocols</i>	17
7.9	<i>Location Privacy</i>	18
7.10	<i>“Moving Network” Support</i>	18
7.11	<i>Paging Support with Location Management</i>	18
7.12	<i>Support of IPv4 and IPv6</i>	18
7.13	<i>Provision of a Handover Management Function for Seamless Services</i>	18
8	Existing Mobility Management Protocols	19

8.1	<i>Mobile IP (MIP)</i>	19
8.1.1	Overview	19
8.1.2	MIP operations	19
8.1.3	MIP extensions: HMIP and FMIP	20
8.1.5	Summary	21
8.2	<i>Session Initiation Protocol (SIP)</i>	21
8.2.1	Overview	21
8.2.2	SIP-based MM	22
8.2.3	Summary	22
8.3	<i>Cellular IP (CIP)</i>	22
8.3.1	Overview	22
8.3.2	CIP with MIP for MM	23
8.3.3	CIP with SIP for MM.....	24
8.4	<i>mobile Stream Control Transmission Protocol (mSCTP)</i>	25
8.4.1	Overview	25
8.4.2	mSCTP for handover in the transport layer	25
8.4.3	Use of mSCTP with location management	27
8.5	<i>3GPP Mobility Management Protocols</i>	27
8.5.1	Network architecture for the PS domain.....	27
8.5.2	3GPP Mobility Management based on the Mobile Application Part (MAP)	29
8.5.3	MIP and SIP in 3GPP system	29
8.5.4	Summary	29
8.6	<i>3GPP2 Mobility Management Protocols</i>	29
8.6.1	Overview of ANSI-41 evolved all-IP MMD core network	29
8.6.2	MM in the ANSI-41 evolved IP MMD core network.....	30
8.6.3	Summary	32
8.7	<i>BRAIN Candidate Mobility Protocol (BCMP)</i>	32
8.7.1	Overview of BCMP	32
8.7.2	BCMP with MIP for MM.....	33
8.7.3	BCMP with SIP for MM.....	34
8.7.4	Summary	34
9	Analysis of the Existing MM Protocols for SBI2K	35
9.1	<i>Review of the Existing MMPs</i>	35
9.2	<i>Candidate Mobility Management Protocols for Mobility Management</i>	36
9.3	<i>Concluding Remarks</i>	37
10	Bibliography	38

1 Scope

The scope of this Supplement is to identify Mobility Management (MM) requirements for Systems Beyond IMT-2000 (SBI2K) and to analyse potential MM protocol candidates based on those requirements.

In developing a common set of MM requirements, the following criteria have been applied:

- they must be compatible with emerging IP-based networks; and
- they must be in line with relevant Vision, Harmonization, and Fixed/Mobile Convergence studies within ITU.

The common set of MM requirements is then used to analyse various MM protocol candidates with the aim of:

- supporting global roaming and advanced services; and
- to the extent possible, re-using the existing specifications from IETF, partner Standards Development Organizations (SDOs) of 3GPP and 3GPP2, IEEE, and other relevant groups.

In order to realize the Vision for SBI2K in the area of MM, it is essential to work closely with experts from the aforementioned and other relevant bodies to ensure a smooth migration path towards meeting longer term MM requirements.

2 References

As this is a Supplement and therefore references are non-normative, a Bibliography has been provided at the end of this document.

3 Definitions

Mobility	The ability for a user to access subscribed services while in motion, and the capability of the network to identify and locate the user's terminal.
Handover	The ability of a mobile user/terminal/network to change location while media streams are active.
Home Network	The network to which a mobile user is normally connected, or the service provider with which the mobile user is associated, and where the user's subscription information is managed.
Visited Network	The network outside home network that provides service to a mobile user.
Mobility Management	The set of functions used to manage a mobile user accessing a local network other than that user's home network. These functions include communication with the home network for purposes of authentication, authorization, location updating and download of user information.
Network Mobility	The ability of a network, where a set of fixed or mobile nodes are networked each other, to changes, as a unit, its point of attachment to the corresponding network upon the network's movement itself.

Roaming	The ability of a mobile user to get connectivity from visited network." During roaming, a user is able to change network access points as he moves. However, his current service session is completely stopped at the old location and a new session is started at the new location, i.e., there is no handover.
Seamless Handover	The process by which latency and data loss incurred during handover are within the range to be acceptable to the users, (e.g., below a certain limit) for real-time services.
Seamless Service	Seamless service will prevent users from experiencing any service disruptions while maintaining mobility.
Terminal Mobility	This is mobility for those scenarios where the same terminal equipment is moving or is used at different locations. The ability of a terminal to access telecommunication services from different locations and while in motion, and the capability of the network to identify and locate that terminal.

4 Abbreviations

3GPP	3rd Generation Partnership Project
3GPP2	3rd Generation Partnership Project 2
AAA	Authentication, Authorization and Accounting
ACK	Acknowledgement
AE	Application Entity
AGW	Access Gateway
AN	Access Network
ANG	Access Network Gateway
ANP	Anchor Point
ANSI	American National Standards Institute
AR	Access Router
ASE	Application Service Entity
BAR	BRAIN Access Router
BCMP	BRAIN Candidate Mobility Protocol
BR	Border Router
BS	Base Station
CCoA	Co-located Care-of Address
CH	Correspondent Host
CIP	Cellular IP
CN	Core Network(s)
CoA	Care-of Address

DB	Database
DHCP	Dynamic Host Configuration Protocol
EIR	Equipment Identity Register
FA	Foreign Agent
FMIP	Fast Handover for MIP
GERAN	GSM EDGE Radio Access Network
GFA	Gateway FA
GGSN	Gateway GPRS Support Node
GPRS	General Packet Radio Service
GSM	Global System for Mobile communication
GTP	GPRS Tunneling Protocol
HA	Home Agent
HLR	Home Location Register
HMIP	Hierarchical MIP
HoA	Home Address
HSS	Home Subscriber Subsystem
IETF	Internet Engineering Task Force
INIT	INITiation
IMS	IP Multimedia Subsystem
IMT	International Mobile Telecommunications
I2K	International Mobile Telecommunications-2000
IOS	Interoperability Specification
IP	Internet Protocol
LMA	Local Mobility Agent
MAP	Mobile Application Part
MAP	Mobility Anchor Point
MIP	Mobile IP
MIPv4	Mobile IPv4
MIPv6	Mobile IPv6
MM	Mobility Management
MMD	Multimedia Domain
MMP	Mobility Management Protocol
MMR	Mobility Management Requirements
MN	Mobile Node
MS	Mobile Station
MSC	Mobile Switching Center
mSCTP	mobile Stream Control Transmission Protocol

MT	Mobile Terminal
MT	Mobile Termination
NNI	Network-to-Network Interface
PC	Paging Cache
PDF	Policy Decision Function
PDN	Packet Data Network
PDS	Packet Data Subsystem
PDSN	Packet Data Serving Node
PDP	Packet Data Protocol, e.g. IP
PLMN	Public Land Mobile Network
PMM	Packet Mobility Management
PS	Packet Service
QoS	Quality of Service
RAN	Radio Access Network
RC	Routing Cache
RFC	Request For Comments
SBI2K	Systems Beyond IMT-2000
SCCP	Signalling Connection Control Part
SCTP	Stream Control Transmission Protocol
SDO	Standards Development Organization
SGSN	Serving GPRS Support Node
SMS	Short Message Service
SIP	Session Initiation Protocol
SS7	Signalling System No.7
TCAP	Transaction Capabilities Application Part
TCP	Transmission Control Protocol
UA	User Agent
UAC	User Agent Client
UAS	User Agent Server
UDP	User Datagram Protocol
UMTS	Universal Mobile Telecommunications System
URI	Uniform Resource Identifier
UTRAN	Universal Terrestrial Radio Access Network
VLR	Visitor Location Register
WLAN	Wireless LAN
xDSL	x Digital Subscriber Lines

5 Introduction

The rationale behind Systems Beyond IMT-2000 (SBI2K) is the convergence of fixed and wireless networks and ultimately migration to interoperable and harmonised network architectures. This network trend is becoming an industry requirement and one of the purposes of such thrust is to provide services transparently to the users across different access arrangements. This document, therefore, asks: “What new mobility management protocols or enhancements to the existing mobility management protocols are needed to support global user mobility and services in SBI2K?”

In this context, this document identifies the Mobility Management (MM) requirements for SBI2K, based on ITU-T Recommendations Q.1702 [7] and Q.1703 [8] and ITU-R Recommendation M.1645 [23]. According to the identified requirements, a number of mobility management protocols are reviewed and analysed with the aim to define the scope of potential Mobility Management Protocol (MMP) solution.

The ability of mobile users to communicate anytime and from anywhere is a key inherent feature of mobile systems. This is facilitated through the use of radio access to allow users to communicate over radio frequencies, and through the use of Mobility Management (MM) protocols to keep track of mobile users’ locations at all times.

Over the years, sophisticated MM techniques have been developed and deployed in mobile systems to effectively manage the registration, authentication, and movement of mobile users. These techniques, however, have been specific to each system deployed, and manage the movement of users within similar cooperating mobile systems (e.g., an IMT-2000 Family Member). Therefore, the provision of seamless service and mobility across heterogeneous systems has been problematic due to several factors:

- Differences in radio access technologies used;
- Differences in available services and their non-portability;
- Differences in MM techniques deployed; and
- Lack of appropriate interoperability mechanism to resolve the above differences between disparate mobile systems.

With the massive growth in the number of mobile users and the continuing deployment of heterogeneous systems (i.e., multiple IMT-2000 Family Members, Wireless LANs (WLANs), Bluetooth), the demand to provide seamless service to mobile users gets stronger with time, and such pursuit presents new challenges and requirements for new types of MM interoperable across heterogeneous systems.

Moreover, future mobile networks are envisioned to have their core networks Internet Protocol (IP)-based, as noted in ITU-T Rec. Q.1702 [7] and ITU-R Rec. M.1645 [23] where the long-term visions for future mobile systems named SBI2K are described from network and radio aspects, respectively. Hence, the future thrust is towards Mobile and Internet convergence. In order to achieve this convergence, new interoperable MM techniques are required.

ITU-T Rec. Q.1702 [7] says that: “There is a definite trend towards integration of access networks (e.g., cellular, wireless local area network, personal area wireless network, satellite systems, and Internet.) Based on this trend, it is envisioned that the network environment of SBI2K will consist of packet-based network infrastructure offering a plethora of converged services.”

A promising solution for the new type of MM in SBI2K should take into account the long-term trends for future networks, the need for a smooth evolution of the infrastructure, and also the issue of backward compatibility with existing networks, particularly those following the standards of the IMT-2000 family.

Long-term trends (as specified in ITU-T Rec. Q.1702 [7]) applicable to MM can be summarized as follows:

- The core network is fully Internet Protocol (IP)-based;
- Large numbers of users require seamless service;
- MM will need to be able to do more than supporting demanding services in higher-speed objects such as vehicles: it will need to support applications with very large IP multimedia traffic needs, and with diversified communications including person-person, machine-to-machine, and machine-to-person and vice versa;
- The concept of seamless service will be extended beyond handover and roaming services within homogeneous networks: seamless service across heterogeneous networks will be provided;
- Support of Moving Networks (e.g., on airplanes, trains or ships); and
- Separation of control and transport functions.

The proposed architecture must support a variety of user mobility modes across disparate access networks, including global roaming and nomadic/seamless mobility.

As an example, a user attaches to a fixed access network (e.g., x Digital Subscriber Lines (xDSL)) and is authenticated via an appropriate mechanism provided by this access system. Then he starts a multimedia session. Later in the same session, the same user moves to a cellular system (e.g., Universal Mobile Telecommunications System (UMTS), cdma2000) and is authenticated via the access-specific security mechanism. Then he may also try to start a multi-media session and this session will be handled by the access network according to the pre-negotiated user profile known in that cellular network. Several problems may arise in the course of this scenario to work in a proper and seamless manner:

- One may need to cope with as many authentication mechanisms as access technologies, for example, respective identities with different login names and passwords;
- The fixed access network has to keep the user's session alive in order to track the movement of the user, thereby consuming resources; and
- Because of possibly different user profiles across heterogeneous domains, seamless mobility management and service offering across disparate systems may not be properly and sufficiently provided due to differences across the systems.

The new type of Mobility Management functions, which would be interoperable across heterogeneous networks, will be able to efficiently address such problems as identification, authentication, and mediation across access technologies arising while accessing the same level of services in a seamless manner across different networks.

This document describes a set of requirements for Mobility Management Protocols (MMPs) in SBI2K. For this purpose, Section 6 considers general features and issues for Mobility Management (MM) in SBI2K. In Section 7, the requirements for MMPs are identified and characterized in SBI2K. Section 8 reviews a set of the candidate MMPs for SBI2K. In Section 9, the candidate MMPs are analysed and compared in terms of the MMP requirements identified in Section 7.

6 Considerations for Mobility Management in SBI2K

This section describes the generic features and considerations associated with mobility management (MM) so as to facilitate the identification of MM requirements and protocols for Systems Beyond IMT-2000 (SBI2K).

6.1 Envisaged Network Environments for SBI2K

In Rec. M.1645 [23], ITU-R has developed a vision for SBI2K. They envisage the SBI2K architecture as shown in Figure 6.1. In this architecture, it is assumed that an operator could have a core network and one or more access networks inclusive of either wireline or wireless access networks and provide to its customers seamless services across these heterogeneous access networks.

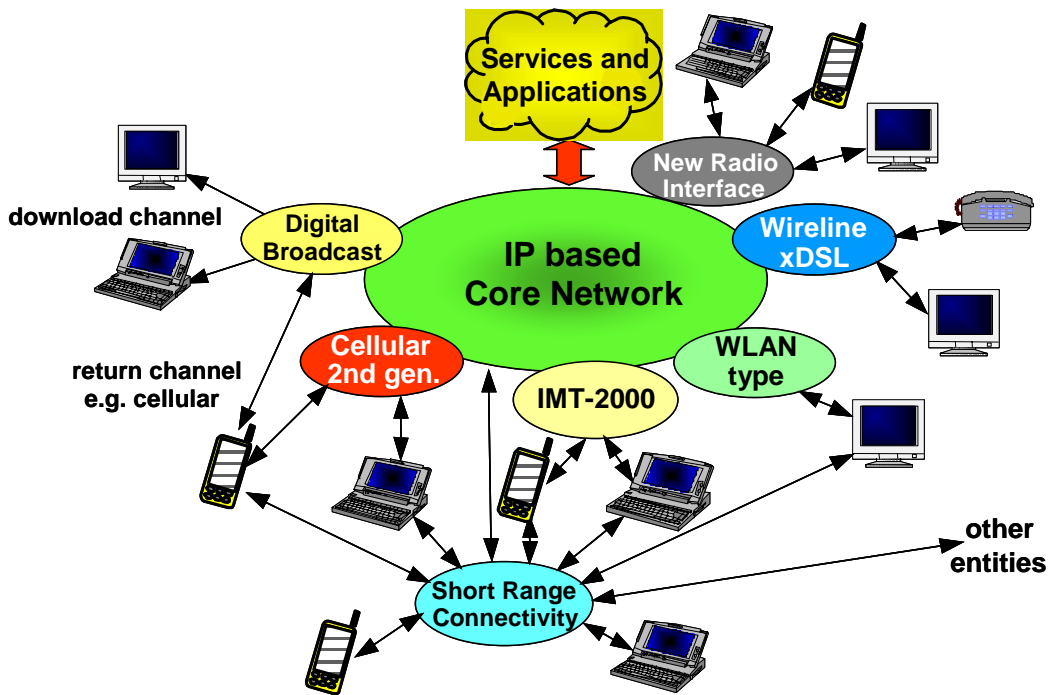

Figure 6.1: Figure 4/ITU-R Rec. M.1465: Future network of Systems Beyond IMT-2000 (SBI2K) including a variety of potential interworking access systems

6.2 Interworking Scenario for SBI2K Network

In order to identify the MM requirements for SBI2K, it would be helpful to envisage the overall network architecture of SBI2K. From the MM perspective, an overall network interworking framework for SBI2K is illustrated as shown in Figure 6.2.

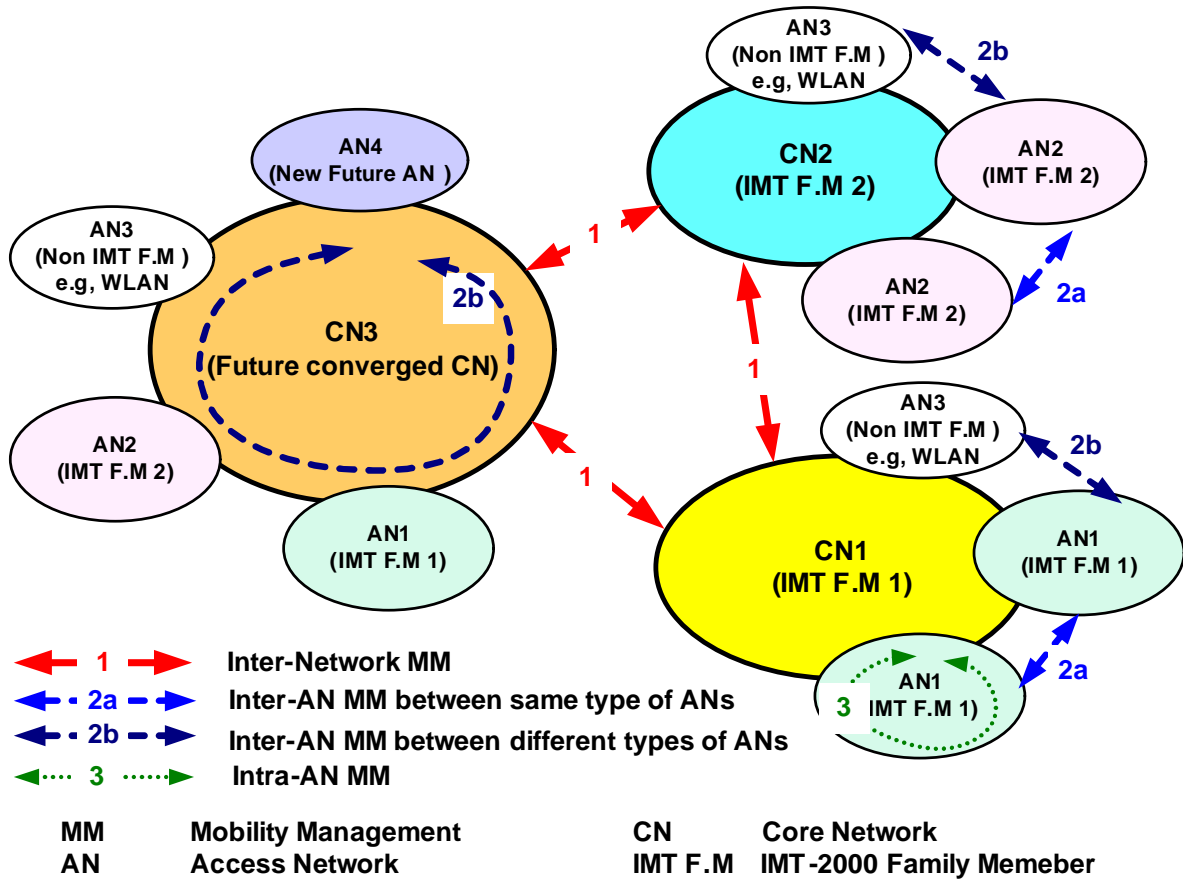

Figure 6.2 Interworking scenario for SBI2K network

In the figure, a Network consists of a Core Network (CN) and one or more Access Networks (ANs). The multiple ANs interwork with each other via the CN.

- Core Network (CN)

Core Network is an architecture term relating to the part of a SBI2K system, which is independent of the connection technology of the terminal.

- Access Network (AN)

An Access Network is an entity or a set of entities between a user and a CN that connects the user to the CN using a particular access technology. Examples of access technologies include Cellular (cdma2000, WCDMA), WLAN, xDSL.

6.3 Level of Mobility Support

The mobility levels to be supported can generically be classified into “nomadic” and “seamless” mobility.

- Seamless Mobility

A user is able to change his network access point, as he moves, without interrupting the current service session, i.e., handovers with performance sufficient for real-time or loss-sensitive applications are supported. In a hostile situation, such handover may still lead to a briefly suspended service session. However, it is desirable to minimize such duration of session interruption as much as possible. Therefore, seamless mobility support will require more advanced and sophisticated MM schemes than other mobility alternatives, e.g. nomadic mobility (to be defined next). The objective of seamless mobility support is to provide seamless session continuity by minimizing the session disruption during handover which occurs due to the associated latency and data loss as the mobile terminal moves into a new access network region and changes its serving network point of attachment.

- Nomadic Mobility

Nomadic mobility supports service continuity but with limited session continuity across the different networks. As a user moves from one network to another, it provides a limited level of handover that may be adequate for non-real time services (e.g., E-mail service), but not for real-time services. Nomadic mobility also includes the limited mobility concept of roaming.

6.4 Basic Mobility Management Functionalities

MM in SBI2K will be realized by using the basic mobility-related functionalities plus the associated functionalities. The basic functionalities are concerned directly with mobility management for mobile users and terminals, whereas the associated functionalities are used for supporting MM or for exchanging related information for overall control and management purposes.

The basic MM functionalities include location and handover management.

- Location Management

Location Management is performed to identify the current network location of a Mobile Terminal (MT) and to keep track of it as it moves. Location management is used for the control of calls and sessions terminated at the MT. Location information is given to the call or session manager for establishing a session. With the help of location management, the correspondent node -is able to locate the MT and establish a session via appropriate signalling.

- Handover Management

Handover Management is used to provide MTs with session continuity whenever they move into different network regions and change their point of attachment to the network during a session. The main objective of seamless handover is to minimize service disruption due to data loss and delay during the handover. Most MM protocols perform handover management together with an appropriate location management scheme. According to the handover areas concerned, the handover types can be classified into “handover within an AN”, where the MT moves across the regions with the same AN in SBI2K systems, and “handover between different AN or CN,” where the MT changes its concerned access system for on-going sessions.

6.5 Classification of Mobility Management

As described in Section 6.3, the MM levels supported can be classified into nomadic and seamless mobility. Usually, seamless mobility is not easy to achieve if a mobile terminal changes the access link technology or network operator while a session is active. Therefore, it is clear that the MM requirements will be different depending on the concerned MM type and in relation to the AN type and the CN operator.

6.5.1 MM types

When considering differences in handover area, the MM issues for SBI2K are classified into Intra-Network MM and Inter-Network MM. Intra-Network MM can be further subdivided into Intra-AN MM and Inter-AN MM.

A more detailed description on Inter-Network and Intra-Network is:

- Intra-Network MM

“Intra-Network” MM addresses MM issues within a network. It can be subdivided into “Intra-AN” MM and “Inter-AN” MM.

- Intra-AN MM

“Intra-AN” MM addresses MM issues within an AN. In Figure 6.2, for example, MM within AN1 of CN1 can be classified as Intra-AN MM, marked as ‘3’ in the figure.

- Inter-AN MM

“Inter-AN” MM addresses MM issues between different ANs within the CN. Inter-AN MM can be further classified into the following two sub-types:

- (1) MM between the same type of ANs (e.g., MM between two AN1’s within the CN1, marked as 2a in Figure 6.2): and
- (2) MM between different types of ANs (e.g., MM between AN1 and AN3 within CN1, marked as 2b in Figure 6.2).

- Inter-Network MM (Network-to-Network (NNI) MM)

“Inter-Network” MM addresses MM issues between networks. Inter-Network MM will always accompany the MM issues between two ANs, i.e., Inter-AN MM. In addition to those, Inter-Network MM must handle the MM issues that occur with MT handovers across different core networks (i.e., Network-to-Network Interface (NNI)), such as user authorization and Service Level Agreement (SLA) negotiation. In Figure 6.2, for example, the MM between CN1 and CN3 is Inter-Network MM, marked as ‘3’ in the figure.

6.5.2 Considerations on MM application from International Mobile Telecommunications-2000 (I2K) Family Member perspectives

MM types classified as above may be applied to the following specific issues in the viewpoints of the I2K Family Members:

- MM at Intra-Family-Member-NNIs

This type of MM corresponds to Intra-AN MM and is partially already defined by the respective SDOs specifying the respective I2K Family Member.

- MM at Inter-Family-Member-NNIs

This type of MM may be mapped to Inter-Network MM. At the NNI between different I2K Family Members, e.g. between Family Members FM1 and FM2, there are in principle three choices:

- (1) Using the NNI MMP specified for internal NNIs within FM1 which will require suitable interworking at the FM2 side.
- (2) Using the NNI MMP specified for internal NNIs within FM2 which will require suitable interworking at the FM1 side.
- (3) Introducing a new “global” NNI MMP which differs from both the FM1 and FM2 protocols and which will require interworking at both sides of the NNI. Such a protocol for use at the NNI between the two different IMT-2000 Family Members could be standardised by direct cooperation of the Partnership Projects specifying the Family Members, or by a third party.

- MM at NNIs which go to non-IMT-2000 Core Networks

Inter-Network MM can also be applied for this MM. This may be identical to, or an evolution of, the MMP specified for use between the IMT-2000 Core Networks (Intra-Family or Inter-Family Member); or it could be another, dedicated MMP, e.g., dedicated for Fixed Mobile Convergence (in case of the NNI between Fixed and Public Land Mobile Network (PLMN) Core Networks), or it could be something else.

It would be desirable if the number of different NNI MMPs to be standardized would not be higher than necessary. By transitioning to IP-based networks, the probability of harmonization of the NNI protocols will increase.

Depending on the kind of NNI, as specified above, it is expected that the requirements for the MMP may vary. It is particularly noted that the “MM Requirements” for Intra-Family Member-NNI and Inter-Family Member-NNI may be different. In Intra-I2K-Family.Member MM, since it is part of the standard of one I2K Family Member, MM requirements are relatively easy to provide. On the other hand, Inter-I2K-Family-Member MM is basically concerned with different protocols applied in different Family Members and thus the corresponding MM requirements may possibly be loosely defined. For the NNI to non-I2K networks, the requirements may even more difficult to specify.

6.6 Consideration of 3GPP and 3GPP2 Activities for Inter-Network MM Supports

In the viewpoint of 3G enhancements, the following points may be considered as short and medium term evolution, as described in [25]

- A harmonized CN between 3GPP and 3GPP2

The target for such harmonization is to support a homogeneous user service experience across heterogeneous access mechanisms interfacing to an access independent harmonized core network. 3GPP and 3GPP2 are adopting a single IP Multimedia Subsystem (IMS) reference model and consistent terminology to describe their common IMS functional entities.

3GPP and 3GPP2 are working to ensure interoperability between 3GPP IMS terminals and 3GPP2 Multimedia Domain (MMD) terminals so that a 3GPP IMS terminal can set up a session with a 3GPP2 MMD terminal and vice-versa, and application level intersystem IMS roaming (given that the terminal supports the visited network's access network and IP transport technology, a 3GPP IMS terminal should be able to roam into a 3GPP2 network and vice-versa.)

- Interworking between mobile networks of 3GPP/3GPP2 and other networks

A similarity of services and applications across the different systems is beneficial to users, and this has stimulated the current trend towards convergence. In the future, operators may deploy a mix of technologies that could incorporate cellular, WLAN, digital broadcast, satellite and other access systems. This will require the seamless interaction of these systems in order for the user to be able to receive a variety of content via a variety of delivery mechanisms depending on the particular terminal capabilities, location and user profile.

Different radio access systems will be connected via flexible CNs. In this way, an individual user can be connected via a variety of different access systems to the networks and services he desires.

7 Requirements for Mobility Management Protocols for SBI2K

This section describes a set of protocol requirements for MM in SBI2K. Based on the identified requirements, candidate MM protocols for SBI2K will be analysed and examined.

- Independence from network access technologies;
- Harmonization with the emerging IP-based Core Networks;
- Separation of control and transport functions;
- Provision of a location management function;
- Provision of mechanisms for identification of users/terminals;
- Interworking with the established Authentication, Authorization and Accounting (AAA), and security schemes;
- Provision of mechanisms for context transfer;
- Effective interworking among different levels of MM protocols;
- Location privacy;
- “Moving network” support;
- Paging support with location management;
- Support of both IPv4 and IPv6; and
- Provision of a handover management function for seamless services.

7.1 Independence from Network Access Technologies

It is expected that SBI2K will consist of an IP based core network with several access networks that may use different access technologies, as shown in Figure 6.1. In this architecture, MM should provide mobility between either homogeneous or heterogeneous types of access networks that belong to the same or different operators. Accordingly, it is required that MM be independent of the underlying access network technologies such as 2/3G Cellular, WLAN, etc.

7.2 Harmonization with the IP-based Core Networks

The future converged CN in SBI2K is envisaged to be IP-based. Accordingly, the MM protocols for SBI2K should be IP-based or, at least, well-harmonized with IP technology for its efficient and integrated operation in such future CNs. It is also recommended to re-use to the extent possible the existing MM techniques/technologies for the design of the MM protocols for SBI2K, potentially through co-operation with external forums and SDOs.

7.3 Separation of Control and Transport Functions

Transport plane should be separated from control plane for efficient mobility management and scalability. Such separation of control and transport planes provides the architectural flexibility that facilitates the introduction of new technologies and services. Open interfaces between the control plane functions and the transport plane functions are necessary to implement their separation.

7.4 Provision of a Location Management Function

To support the mobility of users/terminals, the locations of users/terminals are tracked and maintained by one or more location management functions whenever they move. In harmony with

the overall IP-based structure envisaged, location management should be based on an IP-specific approach such as the Mobile IP Home Agent, or the Session Initiation Protocol (SIP) registrar.

7.5 Provision of Mechanisms for Identification of Users/Terminals

The MM protocols in SBI2K must specify how the users/terminals are to be identified in the networks or systems for mobility management. This identification functionality will be the first step to be taken in the mobility management process and thus used for authentication, authorization and accounting of user/terminal.

7.6 Interworking with Established AAA and Security schemes

The MM protocols for SBI2K must specify how users/terminals are to be authenticated, authorized, accounted, and secured for services using standard AAA and security mechanisms.

The result of the AAA functionality will be a yes/no decision on the service request made by a user. As a next step, the access network configuration will be adapted to the mobile/nomadic user such that it satisfies the particular Quality of Service (QoS) level and security association for the requested service. These mechanisms should be based on the user's subscription profile and the technical resource constraints of the respective access networks.

While it is envisaged that many users will have a terminal for their exclusive personal use, there will also be many cases where terminals must be shared among multiple users (e.g., public telephones) and cases where a particular user, for good and valid reasons, may need to borrow a terminal from another user who normally has exclusive use of his terminal but is willing to let it be used by someone else for good and valid reasons (e.g., an emergency call when the terminal has exhausted its battery.) For these and other circumstances, it is considered essential that the mechanisms for identifying users and terminals be separate, that is, that a user's identity is distinct from a terminal's identity, and that there is a non-permanent association of a user with a particular terminal, which may be transitory or long lasting, depending on the circumstances. Users may also have multiple terminals and will want to be able to transfer from one terminal to another according to their needs. As the overall context is mobility, it is also important that geographic information be separate from the user identity and the terminal identity. The mechanisms to handle all of these will require careful investigation since it will also be essential that they are interoperable with existing naming, numbering, addressing and routing mechanisms.

7.7 Provision of Mechanisms for Context Transfer

When an MT moves across different networks, the context information of the current session, such as QoS level, security method, AAA mechanism, compression type in use, etc., might be helpful in performing the handover of the session to the new access network (e.g., minimizing the latency involved in handing the session over to new serving entities.) The proper use of a context transfer mechanism could substantially reduce the amount of overhead in the servers that are, respectively or in combined manner, used to support QoS, security, AAA and so on.

7.8 Effective Interworking among different level of MM Protocols

For overall seamless mobility, the Inter-Network MM must be able to effectively interwork with the Intra-AN and Inter-AN MM protocols.

7.9 Location Privacy

The location information of particular users should be protected from non-trusted entities. This will entail mutual authentication, security association, and other IP security requirements between the mobile terminal and the location management function.

7.10 “Moving Network” Support

SBI2K are envisioned to include moving networks as well as moving terminals. Typical example platforms for moving networks could be bus, train, ship, aeroplane and so on. The MM protocols in SBI2K need to efficiently support these kinds of moving networks.

7.11 Paging Support with Location Management

The paging capability is essential in large-scale networks because it provides power saving in mobile terminals as well as signalling reduction in networks, which improve the scalability of SBI2K. In particular, paging support needs to be provided together with location management.

7.12 Support of IPv4 and IPv6

The MM protocols must support IPv6 as well as IPv4.

7.13 Provision of a Handover Management Function for Seamless Services

MM should support handover management for maintaining session continuity during movement. This requirement may not be applicable in an environment where the latency for switching access technologies or operators is not acceptable for some applications. However, it is strongly recommended that the MM in SBI2K be able to provide as smooth handover functionality as possible for mobile users who move across different access networks and network operators. The handover management function is also required to be able to operate in concert with the context transfer mechanism.

8 Existing Mobility Management Protocols

This section reviews some of the existing and candidate protocols.

8.1 Mobile IP (MIP)

8.1.1 Overview

Mobile IP (MIP) is a protocol to support IP mobility and is specified in the IETF. Mobile IP may be divided into Mobile IPv4 (MIPv4) and Mobile IPv6 (MIPv6) per the associated IP version. These two protocols basically provide similar functionality with some exceptions in the detailed operation mechanisms. Details of MIPv4 and MIPv6 are described in IETF RFC 3344 [45] and IETF RFC 3775 [46], respectively.

Currently, MIP does not support fast handover for time-critical and loss-sensitive applications. To address this problem, some extensions of MIP, such as Fast Handover for MIP (FMIP) and Hierarchical MIP (HMIP), are being developed in the IETF. It is anticipated that the combination of MIP and its extensions will become a promising candidate for MM in SBI2K as further discussed in Section 9.

8.1.2 MIP operations

MIPv4 operates between the following entities: Mobile Terminal (MT)¹, Home Agent (HA), Foreign Agent (FA) and Correspondent Host (CH). The following figure describes the basic operations of MIPv4.

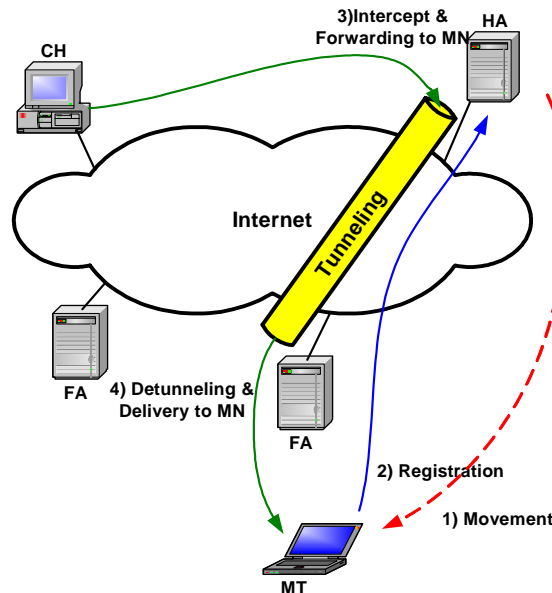

Figure 8.1 Basic operation of MIPv4

When a MT moves into a new subnet, it registers with the HA with a Care of Address (CoA). The CoA could be the FA CoA (IP address of FA) or the Co-located CoA (e.g., obtained by Dynamic

¹ Mobile Terminal (MT) is interchangeable with Mobile Node (MN) as used in [45, 46].

Host Configuration Protocol (DHCP)). The MT must register its CoA with the HA whenever the MT changes its subnet.

If the HA receives packets destined for the MT from the CH, and the MT is roaming in a visited network, the HA intercepts these packets and forwards them to the CoA through the Mobile IP tunnel. The FA (or MT, in case of co-located CoA) decapsulates the received packets from the HA and delivers the original packets to the MT.

8.1.3 MIP extensions: HMIP and FMIP

MIP may not be effective if handovers occur frequently or require real-time applications. To address these issues, a variety of MIP extensions have been proposed. These include Hierarchical MIP (HMIP) and Fast handover for MIP (FMIP).

- Hierarchical MIP

In the case of basic Mobile IP, MT needs to register (or perform a binding update) to the HA and/or CH (when route optimization is applied) whenever an MT changes its subnet. This registration may bring about unnecessary handover latency and signalling overhead. If handover happens more frequently or the HA is far from the MT, this problem becomes more severe.

In the HMIP architecture, access networks are organized hierarchically. Local Mobility Agents (LMAs), called the Gateway Foreign Agents (GFAs) in MIPv4 or the Mobility Anchor Points (MAPs) in MIPv6, are responsible for mobility management of mobile terminals within the domains. Therefore the movement of mobile terminals within the local domain will be hidden from the HA and CH in the other networks, and thus registration latency and signalling overhead can be decreased considerably. The HMIP architecture for MIPv4 is also called “regional registration”.

- Fast handover for MIP

The MIP registration procedures can start only after the link layer handover is complete. It is noted that, if appropriate information could be obtained from the lower-layer (before the link layer handover is completed), the MIP handover latency could be reduced. This is the main concept of the FMIP approach. In addition, a bi-directional tunnel between access routers is used for supporting low loss handover. The low latency handover in Mobile IPv4 and the fast handover for Mobile IPv6 in IETF are possible protocols.

Figure 8.2 shows the architecture of MIP with extensions for MM. As shown in the figure, MM between LMAs will be supported using Mobile IP. Each LMA is used for local mobility management within a local domain. The fast handover protocol is used to support fast handover between access routers within an LMA domain. These LMAs may be organized in a multi-level hierarchy.

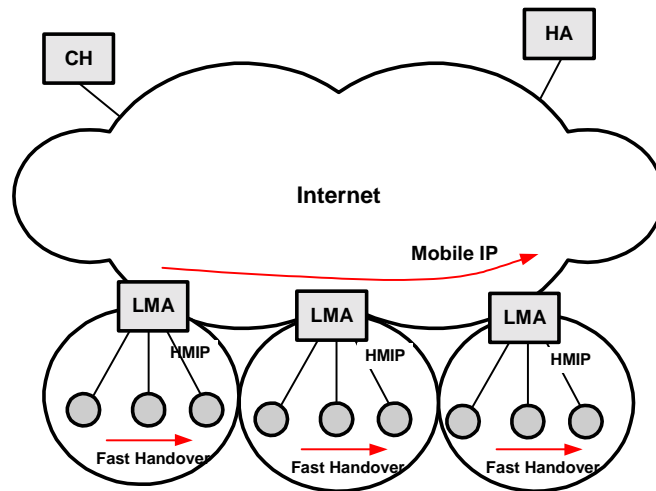

Figure 8.2 MIP and its extensions for MM

8.1.5 Summary

It is noted that the combination of MIP and its extensions for MM is an IP-based approach. Therefore it could easily be integrated into an IP-based network. MIP has already been deployed and its extensions such as FMIP and HMIP could be realized with minimum modification of MIP. This approach may, however, need specific link layer information (such as L2 triggers, e.g., Link Down or Link Up) to support the fast handover of FMIP. In order to use this approach for MM in SBI2K, further work is needed to specify such link layer triggers.

8.2 Session Initiation Protocol (SIP)

8.2.1 Overview

The Session Initiation Protocol (SIP) has been specified in the IETF for supporting the control of IP-based multimedia sessions as a signalling protocol. More details on SIP are given in IETF RFCs 3261 [42].

SIP is an application-layer control protocol that can establish, modify, and terminate multimedia sessions. SIP uses SIP Uniform Resource Identifiers (URIs), which are similar to e-mail addresses, as its addressing scheme. It operates independently of the underlying transport layer protocols such as Transmission Control Protocol (TCP), User Datagram Protocol (UDP) and Stream Control Transmission Protocol (SCTP).

SIP also provides location management functionality for mobility support based on the user's registration with a SIP Registrar. When a SIP User Agent (UA) moves into a new network region, it registers its current location with the location database via a SIP Registrar. The location database is referred to by the SIP proxy server or redirect server during UA originated or terminated session initiation.

The SIP functional entities include the UA, the Proxy Server, the Redirect Server, the Registrar and the Location Database. SIP messages are classified into two types: Request that is sent from the User Agent Client (UAC) to the User Agent Server (UAS), and Response that contains the status of the request.

8.2.2 SIP-based MM

SIP provides location management for terminal mobility. When a mobile terminal moves into a new network, it registers its current location by sending a SIP REGISTER message to the SIP Registrar. The Registrar may deny or accept the request. In the acceptance case, the SIP server will update the location database with the new location information.

When the MT moves into a new network or system, the SIP registration procedure is repeated to update the location. The updated location information will also be referred to by the proxy servers during UA originated or terminated session initiation..

The basic SIP does not provide seamless handover management. Thus, the SIP session is terminated when the MT changes its IP network since the underlying TCP/UDP socket addresses will no longer be valid for the changed IP address.

However, SIP can be used in conjunction with other handover management schemes:

- Mobile IP (MIP)
- Cellular IP (CIP) (or other local mobility protocols); and
- mobile Stream Control Transport Protocol (mSCTP) (in the transport layer).

8.2.3 Summary

SIP has been adopted by 3GPP/3GPP2 as a session/call control protocol and is also widely deployed in other networks. SIP is a promising candidate protocol for location management for MM. It is noted that SIP does not support seamless mobility. For inter-network MM, it could be used along with MIP or SCTP. For intra-network MM, it could be used along with CIP, MIP, or mSCTP.

8.3 Cellular IP (CIP)

8.3.1 Overview

CIP was originally designed for intra-network MM in wireless access networks, and not for inter-network MM. To achieve effective intra-network MM, CIP adopts its own host based routing which requires a Gateway for inter-working with the Internet, as shown in figure 8.3. [47]

CIP routing is accomplished by using CIP-specific Routing or Paging caches in all CIP nodes. The Routing Cache (RC) is used for routing the packets, and the Paging Cache (PC) is used for supporting passive connectivity in the CIP network. The RC and PC are updated by special-purpose update packets sent by the MT.

In CIP, the Home Address (HoA) of the MT is also used as the location ID of the MT in the CIP network. Accordingly, an additional location ID (the CoA of MIP) does not need to be defined, hence there is no need for encapsulation and address conversion in the data transport.

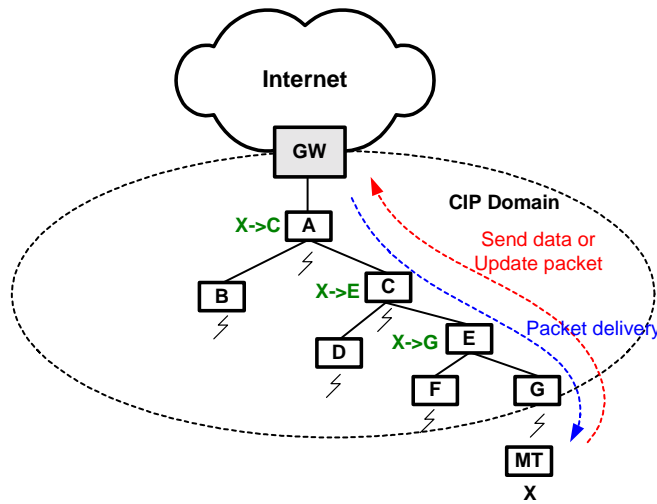

Figure 8.3 CIP operations

As shown in Figure 8.3, each node maintains a forwarding table by using the RC for packet routing and the PC for paging. These caches are refreshed by the data or control packets sent by MT X. The routing or paging information for an MT in the caches is managed by soft state and thus it will expire unless associated update packets arrive within a set lifetime.

If an MT is located in the coverage of node G and has packets to send to the CH, the packets will be forwarded to the CIP Gateway by each node using shortest path routing. The nodes on the data path update their RCs and PCs by these packets. After that, if there are packets destined to the MT from the CH, they are forwarded to the next node according to the forwarding tables in the RCs and PCs. If an MT has no packets to send, it should send update packet to update the routing and paging caches.

8.3.2 CIP with MIP for MM

CIP can be used with MIP for MM. As an example, Figure 8. shows the combination of MIPv4 and CIP for MM. In this scheme, MIPv4 is used for inter-network MM between different CIP networks, whereas CIP is used for intra-network MM in the CIP network. The FAs for MIPv4 are located at the CIP Gateway.

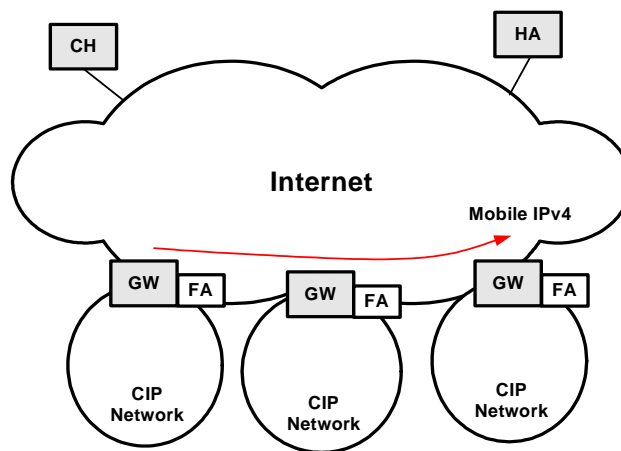

Figure 8.4 CIP with MIPv4 for MM

When an MT enters a CIP region, it first performs MIPv4 registration by sending binding update messages to the HA and/or CH (when route optimization is applied) which will be delivered via the CIP GW. After that, movement in the CIP domain is managed by the CIP protocol. If the MT moves into another CIP domain, it should perform MIPv4 registration again. The associated timing diagram is shown in Figure 8.5.

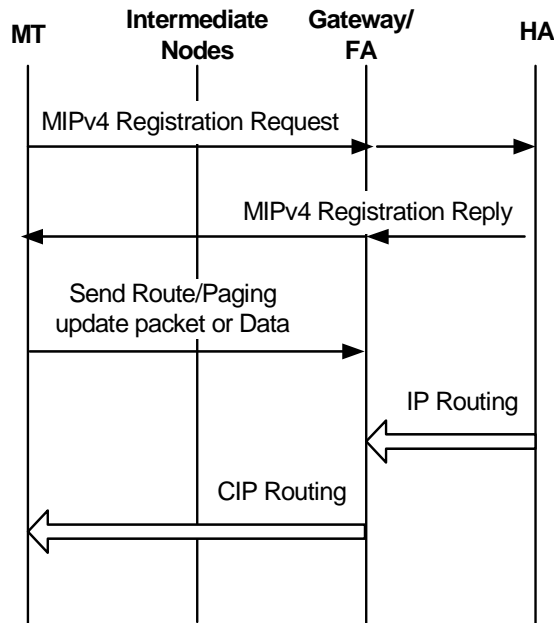

Figure 8.5 Call flow for CIP with MIPv4

8.3.3 CIP with SIP for MM

Figure 8.6 shows the architecture based on the combination of SIP and CIP.

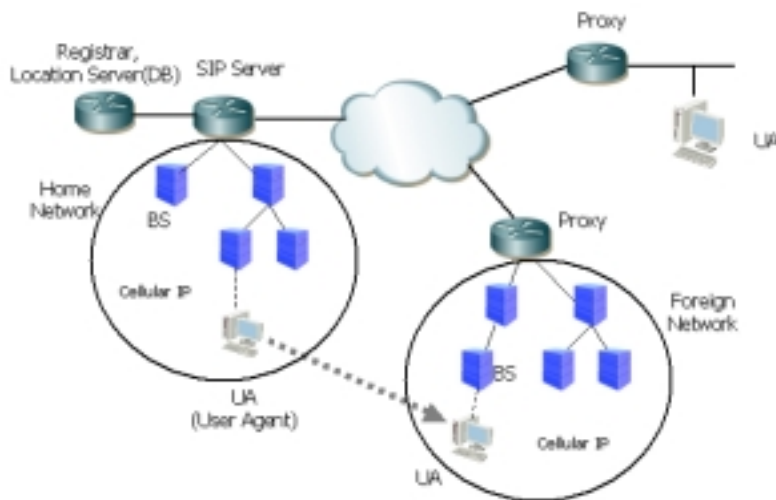

Figure 8.6 - Architecture of CIP with SIP

CIP can be used in conjunction with SIP; where CIP performs Intra-Network MM and SIP is used for Inter-Network MM. However, SIP can only provide Location Management but not Handover Management.

As shown in Figure 8.6, a SIP system is composed of a SIP proxy, a SIP Registrar and a UA, and a CIP network consists of a Gateway and Base Stations (BSs). The SIP server (proxy) is used to track the movement of a UA (MT) in the home and foreign networks. The SIP server functions as a CIP gateway. Cellular IP is used to support seamless mobility within the CIP domain.

When a UA is powered on in its home network, it registers its current location information with the SIP server located in the home network. While the UA moves within the CIP domain after the SIP registration, intra-network MM is accomplished by using the CIP protocol. If the UA moves to another CIP network, it needs to re-register to provide its current information to the home SIP server, which may be done with help of the foreign proxy.

SIP registration includes procedures for location update and deletion for the UA. When the UA moves into a new CIP network, it has to register its current location with the Registrar. The information will be referred to in call setup signalling for the MT.

8.4 mobile Stream Control Transmission Protocol (mSCTP)

8.4.1 Overview

The Stream Control Transmission Protocol (SCTP) as defined in IETF RFC 2960 [36] is an end-to-end, connection-oriented protocol that transports multiple data streams.

The multi-homing feature of SCTP enables SCTP endpoints to support multiple IP addresses. Multi-homing protects an association from potential network failures by steering traffic to alternate IP addresses. During the initiation of an association, SCTP endpoints exchange lists of IP addresses. Therefore, each endpoint can send and receive messages from any of the IP addresses listed at the remote endpoint. For example, one of the listed IP addresses will be designated as the primary address during the initiation. If the primary address repeatedly drops data packets, all the subsequent data packets will be transmitted to an alternate address until a connection to the primary address can be re-established.

It is noted that the multi-homing feature of the SCTP can support IP mobility. More specifically, the SCTP with an extension of dynamic address configuration can be used to provide smooth handover for mobile terminals (MTs) that are moving into different IP network regions during an active session. This is called mobile SCTP (mSCTP) and it is applicable to both IPv4 and IPv6.[48]

mSCTP is a promising handover scheme. Unlike the Mobile IP based handover schemes which rely on the support of network routers for tunnelling between access routers, mSCTP provides handover management at the transport layer without additional change of the existing routers.

8.4.2 mSCTP for handover in the transport layer

mSCTP can be used to provide handover for a mobile terminal that is moving between two different IP networks characterized by different IP address prefixes. This section describes the generic algorithm of mSCTP for handover in IP networks.

Consider a Mobile Terminal (MT) that initiates an SCTP association with a Correspondent Host (CH). After initiation of an SCTP association, the MT moves from Location A (Access Router A) to Location B (Access Router B), as shown in Figure 8.7 which illustrates an example of the use of mSCTP for handover in IPv6 networks. The handover procedures are described in more detail below. This example can be similarly applied to IPv4 networks.



Figure 8.7 mSCTP for handover

- Session initiation by mobile terminal

An MT initiates an SCTP association with a CH. The MT gets an IP address from Access Router (AR) A via IPv6 stateless address auto-configuration or DHCPv6.

- Obtaining an IP address for a new location

The MT moves from AR A towards AR B and enters the overlapping coverage region for the two ARs. The MT obtains a new IP address 3 from AR B by using DHCPv6 or IPv6 stateless address auto-configuration. The newly obtained IP address 3 is signalled to the SCTP in the transport layer, and then the SCTP binds the new IP address to the address list managed by the SCTP association.

- Adding the new IP address to the SCTP association

After obtaining a new IP address, the MT's SCTP informs the CH's SCTP that it will use a new IP address. This is done by sending an SCTP Address Configuration Change (ASCONF) to the CH. The MT may receive the responding ASCONF-ACK from the CH.

The MT is now in a dual homing state. The old IP address (IP address 2) is still used as the primary address, until the new IP address 3 is set to be the "Primary Address" by the MT. Before the new primary address is set, IP address 3 is used as a backup path.

- Changing the primary IP address

As the MT further continues to move towards AR B, it needs to change the new IP address into its primary IP address according to an appropriate rule. The configuration of a specific rule to trigger this "primary address change" is a challenging issue in the development of the mSCTP.

Once the primary address is changed, the CH sends data to the MT's new primary IP address (IP address 3). Any lost data may be retransmitted to the MT's backup (old) IP address (IP address 2)

- Deleting the old IP address from the SCTP association

As the MT continues to move towards AR B, if the old IP address (IP address 2) becomes inactive, the MT deletes it from the address list. The rule for determining if the IP address is inactive may be determined using additional information from the underlying network or physical layer.

The procedural steps for seamless handover described above are repeated whenever the MT moves to a new location, until the SCTP association is released.

8.4.3 Use of mSCTP with location management

To support mobile sessions that are initiated by a CH toward an MT, mSCTP may be used along with a location management scheme such as SIP or MIP. In this scenario, SIP or MIP is used for a CH to locate an MT and to establish an SCTP association with the MT. After an SCTP association is successfully set up, mSCTP will be used for providing seamless handover for the MT. Once the association is established, data transport between the MT and the CH relies only on mSCTP, and does not use MIP.

- **mSCTP with SIP**

SIP is an application layer protocol, whereas SCTP is a transport layer protocol. In this scenario, SIP is used for location management and call control signalling. Once an SIP session is established (e.g., over TCP/UDP/SCTP), a new SCTP association can be used for data transport between the two concerned UAs. The transport of real-time data over mSCTP is for further study. When the UA moves to a new AR, the mSCTP handover mechanisms are applied and the SIP registration procedure is invoked to update its new address into the location database.

- **mSCTP with MIP**

In this scenario, the location management function of MIP is used to deliver SCTP initiation signal from CH to the MT. Once an SCTP initiation is successfully established, the handover management follows the procedures of mSCTP. (Refer to Section 8.4.2 for details.)

8.5 3GPP Mobility Management Protocols

The core network technical specifications for GSM evolved UMTS core network have been developed in a third Generation Partnership Project (3GPP) and transposed to the involved regional Standards Development Organizations (SDOs). This section describes the MM protocol for packet service of 3GPP Release 5, as documented in the 3GPP Technical Specifications referred to in ITU-T Rec. Q.1741.3 [13].

8.5.1 Network architecture for the PS domain

The Packet Service (PS) domain of the 3GPP Release 5 Core Network includes the General Packet Radio Service (GPRS) subsystem and the components used for Mobility Management (MM) [13].

The packet domain uses packet-mode techniques to transfer high-speed and low-speed data and signalling in an efficient manner. The packet domain optimises the use of network and radio resources. Strict separation between the radio subsystem and the network subsystem is maintained, allowing the network subsystem to be reused with other radio access technologies.

A common packet domain Core Network is used for both Radio Access Networks (RAN), the GSM EDGE Radio Access Network (GERAN) and the Universal Terrestrial Radio Access Network (UTRAN). This common Core Network provides, together with these RANs, GPRS services. It is

designed to support several quality of service levels to allow efficient transfer of non real-time traffic (e.g., intermittent and bursty data transfers, occasional transmission of large volumes of data) and real-time traffic (e.g., voice, video). Applications based on standard data protocols and Short Message Service (SMS) are supported, and interworking is defined with IP networks.

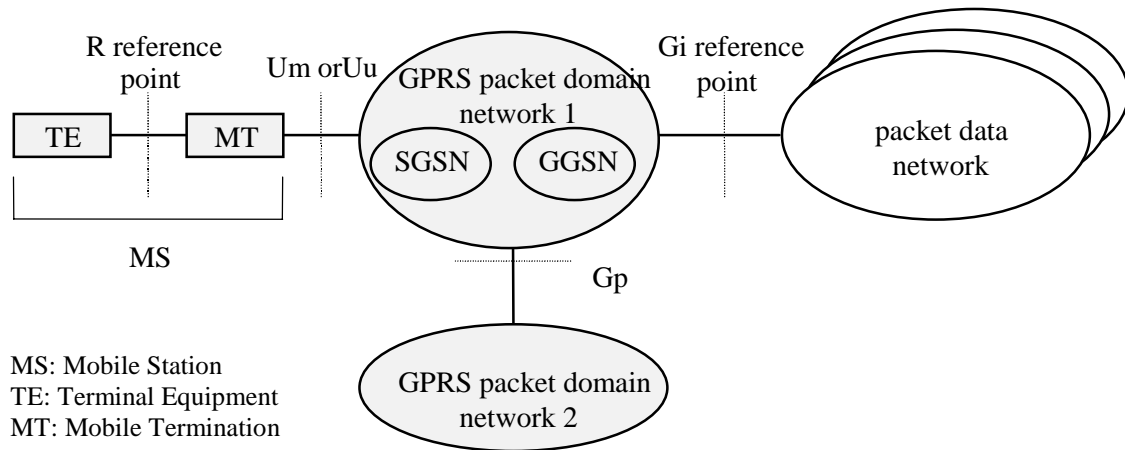

Figure 8.8 3GPP architecture for Packet Data Service (GPRS system)

The Serving GPRS Support Node (SGSN) keeps track of the location of an individual Mobile Terminal (MT) and performs security functions and access control. The Mobility Management (MM) activities related to a subscriber are characterised by one of three different MM states. In A/Gb mode, the MM states for a GPRS subscriber are IDLE, STANDBY, and READY. In Iu mode, the MM states for a GPRS subscriber are Packet Mobility Management (PMM) DETACHED, PMM IDLE, and PMM CONNECTED. Each state describes a certain level of functionality and information allocated. The information sets held at the MT and the SGSN are denoted MM context.

The MM state relates only to GPRS MM activities of a subscriber. The MM state is independent of the number and state of Packet Data Protocol (PDP) contexts for that subscriber.

The Gateway GPRS Support Node (GGSN) provides interworking with packet data networks, and is connected with SGSNs via an IP-based packet domain PLMN backbone network.

The Home Location Register (HLR) contains subscriber information.

Optionally, the Mobile Switching Center (MSC)/Visitor Location Register (VLR) can be enhanced for more-efficient co-ordination of packet-switched and circuit-switched services and functionality, e.g., combined GPRS and non-GPRS location updates.

In order to use GPRS services, an Mobile Terminal (MT) must first make its presence known to the network by performing a GPRS attach. This makes the MT available for paging via the SGSN, and notification of incoming packet data.

In order to send and receive packet data by means of GPRS services, the Mobile Terminal (MT) must activate the Packet Data Protocol context that it wants to use. This operation makes the MT known in the corresponding GGSN, and interworking with data networks can commence.

User data is transferred transparently between the Mobile Terminal (MT) and packet data networks with encapsulation and tunnelling: data packets are equipped with GPRS-specific protocol information and transferred between the MT and the GGSN. This transparent transfer method lessens the requirement for the PLMN to interpret external data protocols, and it enables easy introduction of additional interworking protocols in the future.

8.5.2 3GPP Mobility Management based on the Mobile Application Part (MAP)

It is necessary to transfer information between entities of a PLMN to deal with roaming MTs.

In the 3GPP system, this information transfer is achieved by means of the Mobile Application Part (MAP) specified by 3GPP as an Application Service Entity (ASE) within the Application Entity (AE) riding on Signalling System No.7 (SS7) specified by ITU-T in the Q.700-series Recommendations covering the Message Transfer Part (MTP, Q.70x-series), Signalling Connection Control Part (Signalling Connection Control Part (SCCP), Q.71x-series) and Transaction Capabilities Application Part (TCAP, Q.77x-series). The structure of an Application Entity and its ASEs, and its position within SS7, is described in ITU-T Rec. Q.1400 [5].

3GPP TS 29.002 [27] specifies the Mobile Application Part (MAP), the requirements for the signalling system and the procedures needed at the application level in order to fulfil these signalling needs.

MAP is also used as the MMP in the packet domain (GPRS domain) of the 3GPP system.

8.5.3 MIP and SIP in 3GPP system

The GPRS network includes the support of optional MIP services for Inter-Network MM.

To support the optional Mobile IP services efficiently by GPRS, Foreign Agent (FA) functionality needs to be provided in the GGSN [26]. The interface between the GGSN and the FA, including the mapping between the care of IP address and the GPRS Tunnelling Protocol (GTP) tunnel in the PLMN, is not standardized as the GGSN and FA are considered to be one integrated node.

SIP is used as the call control protocol for IP-based Multimedia Core Network Subsystem (IMS) in 3GPP Release 5 [13]. The SIP based user registration, in combination with the Home Subscriber Subsystem (HSS), provides a level of location tracking which is independent from the access technology.

8.5.4 Summary

For Intra/Inter-Network MM in the 3GPP system, location tracking and mobility in the PS domain are based on the MM procedures in GPRS using protocols such as GTP and GSM MAP.

For Inter-Network MM, MIP can be optionally deployed in the GGSN.

Starting from Release 5, 3GPP has specified IMS which is based on SIP and which provides SIP based MM in addition to the existing GPRS based MM.

8.6 3GPP2 Mobility Management Protocols

This section describes the American National Standards Institute (ANSI)-41 evolved IP Multimedia Domain (MMD) Core Network from the point of view of 3GPP2 MMP, which is based on ITU-T Rec. Q.1742.3 [16]

8.6.1 Overview of ANSI-41 evolved all-IP MMD core network

The core network for cdma2000 is based on an ANSI-41 evolved system. The core network technical specifications have been developed in the third generation partnership project 2 (3GPP2) and transposed to the involved regional Standards Development Organizations (SDOs).

The system supports different applications ranging from narrow-band to wide-band communications capability with integrated personal and terminal mobility to meet the user and service requirements.

The basic architecture for the ANSI-41 evolved Core Network with cdma2000 Access Network family member includes a circuit-based and packet based core network and an all-IP multimedia domain (MMD). The all-IP MMD core network could be considered as a candidate core network for SBI2K. Figure 8.9 presents the overall architecture of the ANSI-41 evolved all-IP Core Network with cdma2000 Access Network that is defined in ITU-T Rec. Q.1742.3 [16].

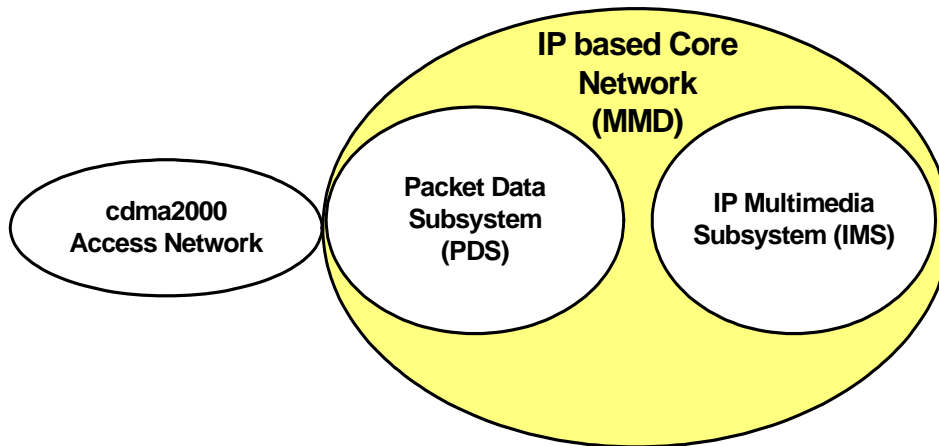

Figure 8.9 Simplified architecture of ANSI-41 evolved all-IP MMD Core Network with cdma2000 access network

The MMD of the All-IP Network offers both general packet data support and multi-media session capabilities (IP Multimedia Subsystem (IMS)). The multi-media session capabilities are built on top of the general packet data support capabilities. The general packet data capabilities may be deployed without the multi-media session capabilities. Some network entities are common to providing both capabilities.

SIP is used as the call control protocol for IMS in 3GPP2 system. The SIP based user registration, in combination with the HSS, provides a level of location tracking which is independent from the access technology.

8.6.2 MM in the ANSI-41 evolved IP MMD core network

Figure 8.10 shows the Packet Data Subsystem (PDS) of the ANSI-41 evolved IP MMD core network. The functionality of each entity is as follows.

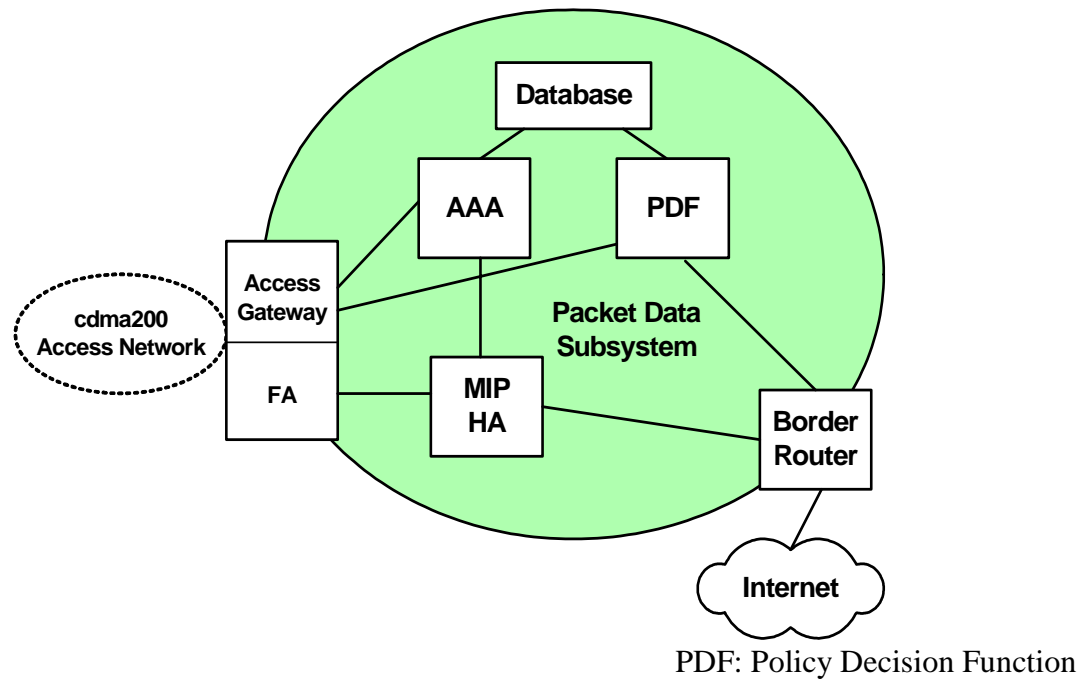

Figure 8.10 PDS of ANSI-41 evolved all-IP MMD Core Network

- Access Gateway (AGW)

The cdma2000 AGW consists of the Packet Data Serving Node (PDSN) and other logical functions required to interface the core network to the cdma2000 Access Network (AN). The PDSN routes MT originated and MT terminated packet data traffic. The PDSN establishes, maintains, and terminates the link layer sessions to MTs.

- Mobile IP Home Agent (HA)

The HA provides two major functions: registering the current point of attachment of the user, and forwarding of IP packets to and from the current point of attachment (IPv4 Care of Address or IPv6 Co-located CoA) of the user. The HA accepts registration requests using the Mobile IP protocol and uses the information in those requests to update internal information about the current point of attachment of the user, i.e., the current IP address to be used to transmit and receive IP packets to and from that user.

The HA interacts with AAA server to authenticate and authorize Mobile IP registration requests and returns Mobile IP registration responses. The HA also interacts with the AGW to receive subsequent Mobile IP registration requests.

- Authentication, Authorization and Accounting (AAA) server

The AAA server provides IP based Authentication, Authorization, and Accounting. The AAA server maintains security associations with peer AAA entities to support intra- or inter-administrative domain AAA functions. The Authentication Function provides Authentication of terminal devices and subscribers. The Authorization Function of AAA provides authorization of requests for services and has access to the policy repository, the directory services, subscriber profiles, and the device registrar. The Accounting Function gathers data related to the services, QoS, and multimedia resources requested and used by individual subscribers.

- Database (DB)

The information in the core network DBs may include but is not limited to Equipment Identity Register (EIR), dynamic subscriber information, network policy rules and subscriber profiles.

- Border Router (BR)

The BR connects the Core Network with peer networks (e.g., other service providers, corporate networks, the Internet). The BR performs IP packet routing, handles exterior gateway routing protocols, and ensures the incoming and outgoing traffic to be compliant with the pre-established Service Level Agreements between peer networks.

- Policy Decision Function (PDF)

The PDF provides management of core network QoS resources within its own core network necessary to support services to network users.

8.6.3 Summary

For Intra-Network MM in the 3GPP2 system, location and handover management are realized using protocols such as MIP, ANSI-41, and Interoperability Specification (IOS).

For Inter-Network MM, MIP can be used.

3GPP2 has additionally specified location management of Inter-Network and Intra-Network MM based on SIP (IMS).

8.7 BRAIN Candidate Mobility Protocol (BCMP)

8.7.1 Overview of BCMP

The BCMP (BRAIN Candidate Mobility Protocol) protocol [BCMP] was developed in the framework of the BRAIN project in order to improve existing mobility schemes. Figure 8.11 shows the outline operation. Generally, the access networks consist of legacy IP routers and, in order to support the BCMP protocol, additional functionalities are needed to be supported by the access network:

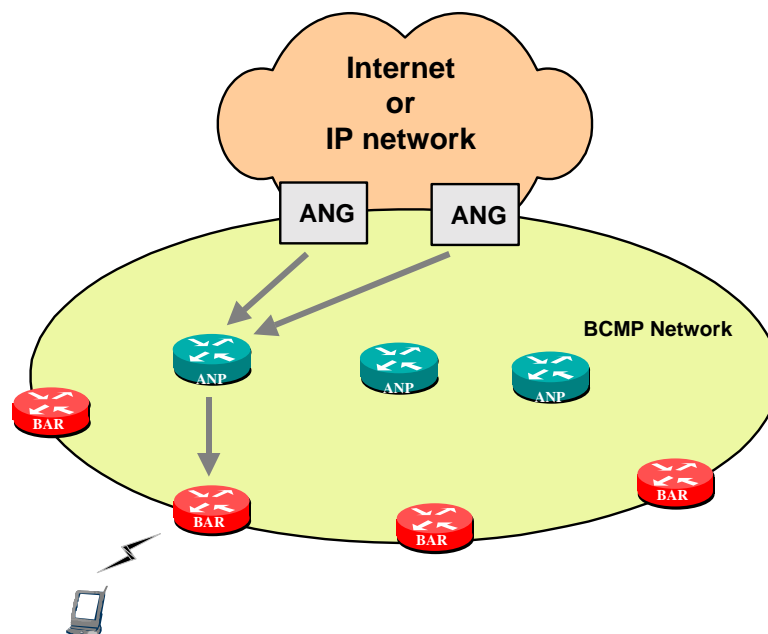

Figure 8.11 BCMP architecture

- The BRAIN Access Routers (BARs), located at the edge of the BRAIN AN, offer IP connectivity to mobile terminals (MTs). They act as the default routers for the MTs that they serve.
- The Anchor Points (ANPs) are located inside the AN at selected positions. ANPs own and allocate IP addresses, authenticate users, maintain user records and tunnel packets towards MTs.

In this context, an Access Network Gateway (ANG) doesn't need to have mobility specific functionality because it acts as a standard border router, isolating the AN from the exterior routing protocols and distributing traffic to the correct ANP. The mobility specific functionality is provided by ANPs, thus decoupling the boundary functionality provided by ANGs. This role separation allows a more flexible deployment and establishes an explicit boundary for the AN.

ANPs have globally routable address spaces and they allocate IP addresses to MTs when they log in to the AN. An MT's address is kept constant while the MT is moving inside the AN. This ensures that packets addressed to the MT's address are prefix-based routed to the ANP which allocated that address. This ANP tunnels the packets to the BAR where the destination MT is currently located. ANPs need to maintain updated location information of MTs for which they have allocated an address, and update this information when these MTs change their BAR. Additionally, there exists a change mechanism for the ANP which may be activated when the route towards the MT is inefficient. The BCMP supports handover and paging.

8.7.2 BCMP with MIP for MM

Figure 8.12 shows the combination of MIP and BCMP for MM. In this scheme, MIP is used for Inter-Network MM between different BCMP networks, whereas BCMP is used for Intra-Network MM in each of the BCMP networks. The FA's address configuration functionality for MIP is located at the ANP.

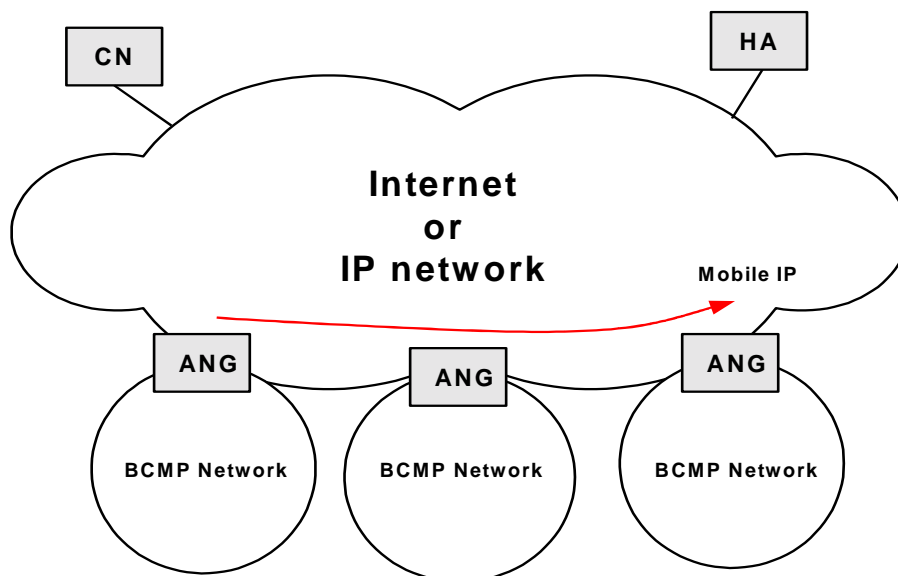

Figure 8.12 Architecture of BCMP with MIP for MM

When a MT enters a BCMP region, it acquires an IP address using the access network procedures of BCMP and is then able to use it as a Co-located Care-of Address (CCoA) in the MIP sense. The subsequent registration messages with the Home Agent, which can be anywhere in the Internet or IP network, or Binding Updates, e.g., for route optimisation, are totally transparent. Inside the BCMP

9 Analysis of the Existing MM Protocols for SBI2K

This section provides a high level comparison of the existing MMPs considered in this document.

9.1 Review of the Existing MMPs

The following table summarizes the generic characteristics of the existing MM protocols that are described in Section 8.

Table 9.1 Features of the existing MM protocols

Features	Characteristics of MM protocols
MIP	<ul style="list-style-type: none"> - Network layer protocol - Provides location management and limited handover management functionalities - Needs mobility agents such as HA, FA (MIPv4) - Supports route optimisation - Standardized in IETF - Needs MIP extensions for seamless handover support
MIP with Extensions	<ul style="list-style-type: none"> - Network layer protocol - Supports all features of MIP in addition to following features: <ul style="list-style-type: none"> · Provides seamless handover management · HMIP needs mobility agents such as GFA (MIPv4), MAP (MIPv4); FMIP needs enhanced ARs · HMIP reduces signalling traffic loads · Still undergoing development
SIP	<ul style="list-style-type: none"> - Application layer protocol - Provides location management - Does not require route optimisation - Standardized in IETF - Could be used with CIP, MIP (with or without MIP extensions), mSCTP for handover management
CIP	<ul style="list-style-type: none"> - Network layer protocol - Provides handover management and limited location management - Needs CIP nodes for routing and a CIP Gateway for interworking - Does not require route optimisation - Still undergoing development - Could be used with MIP and SIP for location management
mSCTP	<ul style="list-style-type: none"> - Transport layer protocol - Provides handover management- Needs no network support - Does not require route optimisation - Still undergoing development - Could be used with MIP and SIP for location management
3GPP MM	<ul style="list-style-type: none"> - Provides handover management and location management - Needs SGSN, GGSN for packet service - Standardized in 3GPP - Associated with radio access technology of 3GPP - Optionally support MIP

Features	Characteristics of MM protocols
3GPP2 MM	<ul style="list-style-type: none"> - Provides handover management and location management - Needs HA, FA/PDSN - Standardized in 3GPP2 - Must support MIP
BCMP	<ul style="list-style-type: none"> - Network layer protocol - Provides handover management and limited location management - Needs BCMP-specific routers such as ANP, BAR and gateways, ANG - Does not require route optimisation - Still undergoing development - Requires interworking with other MM protocols such as SIP and MIP

9.2 Candidate Mobility Management Protocols for Mobility Management

The CIP and BCMP may not be suitable for Inter-Network MM protocols in SBI2K because they have been designed mainly for Intra-Network MM. mSCTP may also not be appropriate for Inter-Network MM, because it is an end-to-end solution. Also, all the possible extensions including MIP extension were not considered at this time as candidate protocols for MM because they are still undergoing development.

It is also noted that the 3GPP2 MM is based on MIP for packet data services, and it thus can be categorized as the same category as MIP.

Accordingly, among the existing MM protocols, MIP, SIP and 3GPP MM could be considered as candidate protocols for MM for SBI2K.

In this section, the candidate MM protocols (MIP, SIP and 3GPP MM) are analysed in term of the requirements for MM protocols for SBI2K.

Table 9.2 Candidate protocols for MM

Requirements	MIP (Used by 3GPP2 MM)	SIP (Used by IMS)	3GPP MM
Independence from network access technologies	○	○	△
Harmonization with IP-based core networks	○	○	△
Physical separation of control and transport traffic	△	△	○
Logical separation of control and transport traffic	○	○	○
Location Management	○	○	○
Identification of users/terminals	○	○	○
Interworking with AAA and security schemes	○	○	○

Context transfer	△	△	○
Interworking with Intra-Network MM	○	△	○
Location privacy	○ (If RO is not used)	△	○
“Moving network” support	△	△	△
Paging support	△	△	○
Support of both IPv4 and IPv6	○	○	○
Seamless handover management	△	△	○

Note: ○ (support), △(might be supported)

- MIP

MIP is an IP-based network layer solution and independent of the underlying access network technologies. It could be well harmonized with the IP-based core networks because it is IP-based. The location management and limited handover management are supported by MIP. Context transfer and moving network support are currently being developed based on MIP in IETF. It is also expected that paging could be supported. MIP supports both IPv4 and IPv6.

However, it depends on the version of IP, as shown in MIPv4 and MIPv6. In the case of IPv4 and IPv6 networks coexisting in SBI2K, interworking between MIPv4 and MIPv6 will be required to support seamless mobility. The base MIP specification is not enough for providing the seamless handover management for real-time or loss-sensitive applications, and thus an enhancement or extension of MIP is required such as FMIP and HMIP.

- SIP

SIP is a peer-to-peer signalling protocol that is designed for supporting session control in IP-based multimedia sessions, and is also widely deployed in other networks. SIP could provide location management function through the SIP Registrar. It could be well harmonized with IP-based core networks. It is also noted that most future systems including SBI2K will consider SIP as a signalling protocol. It could also operate independently of the underlying access technologies. SIP is independent of the IP version since it is an application layer solution.

However, SIP could not support seamless handover management and thus needs further enhancements.

- 3GPP MM

3GPP MM could provide handover and location management and could meet most of the MM requirements. However, it may need further enhancements to support a variety of heterogeneous access networks.

9.3 Concluding Remarks

This document has identified a set of MM requirements for Systems Beyond IMT-2000 (SBI2K). Based on these requirements, existing MM protocols or schemes have been reviewed and examined, including Mobile IP, SIP, Cellular IP, mSCTP, BCMP, 3GPP MM and 3GPP2 MM. It is noted that these protocols range from being under development to standardized.

This document also considers which of the existing MM protocols could be used for MM in the SBI2K environment, and whether a new framework or protocol for MM needs to be developed from the point of SBI2K. According to the analysis, the following MM protocols are considered as candidate MM protocols: MIP, SIP, and 3GPP MM.

However, it is observed that no single instance of the existing MM protocols could support all of the MM requirements for SBI2K. In this respect, it may be necessary to identify a new MM framework and functional architecture for SBI2K. This will be followed by the development of the MM functional model and its corresponding message flows. This framework will also incorporate or extend the existing MM protocols, such that it can provide the MM for current and emerging access/core networks.

10 Bibliography

The following documents are provided as non-normative references:

- [1] ITU-T Recommendation M.3100 (1995), "Generic network information model"
- [2] ITU-T Recommendation E.164 (1997), "The international public telecommunication numbering plan"
- [3] ITU-T Recommendation E.212 (1998), "The international identification plan for mobile terminals and mobile users."
- [4] ITU-T Recommendation Q.1290 (1998), "Glossary of terms used in the definition of intelligent networks"
- [5] ITU-T Recommendation Q.1400 (1993), "Architecture framework for the development of signalling and OA&M protocols using OSI concepts"
- [6] ITU-T Recommendation Q.1701 (1999), "Signaling requirements and protocols for IMT-2000"
- [7] ITU-T Recommendation Q.1702 (2002), "Long-term vision of network aspects for systems beyond IMT-2000"
- [8] ITU-T Recommendation Q.1703 (2004), "Service and Network Capabilities Framework of Network Aspects for Systems Beyond IMT-2000"
- [9] ITU-T Recommendation Q.1711 (1999), "Network functional model for IMT-2000"
- [10] ITU-T Recommendation Q.1721 (2000), "Information flows for IMT-2000 capability set 1"
- [11] ITU-T Recommendation Q.1741.1 (2002), "IMT-2000 References to Release 1999 of GSM Evolved UMTS Core Network with UTRAN Access Network"
- [12] ITU-T Recommendation Q.1741.2 (2002), "IMT-2000 References to Release 4 of GSM evolved UMTS Core Network with UTRAN Access Network"
- [13] ITU-T Recommendation Q.1741.3 (2003), "IMT-2000 References to Release 5 of GSM evolved UMTS Core Network"
- [14] ITU-T Recommendation Q.1742.1 (2002), "IMT-2000 References to ANSI-41 evolved Core Network with cdma2000 Access Network"
- [15] ITU-T Recommendation Q.1742.2 (2003), "IMT-2000 References (approved as of 11 July 2002) to ANSI-41 Evolved Core Network with cdma2000 Access Network"

- [16] ITU-T Recommendation Q.1742.3 (2004), "IMT-2000 References (approved as of 30 June 2003) to ANSI-41 Evolved Core Network with cdma2000 Access Network"
- [17] ITU-T Recommendation Q.1761 (2004), "Principles and requirements for convergence of fixed and existing IMT-2000 systems"
- [18] ITU-R Recommendation M.687-2 (1997), "International Mobile Telecommunications"
- [19] ITU-R Recommendation M.816-1 (1997), "Framework for services supported on International Mobile Telecommunications-2000 (IMT-2000) "
- [20] ITU-R Recommendation M.1034-1 (1997), "Requirements for the radio interface(s) for International Mobile Telecommunications-2000 (IMT-2000) "
- [21] ITU-R Recommendation M.1168 (1995), "Framework of International Mobile Telecommunications-2000 (IMT-2000)"
- [22] ITU-R Recommendation M.1224 (1997), "Vocabulary of terms for International Mobile Telecommunications-2000 (IMT-2000)"
- [23] ITU-R Recommendation M.1645 (2003), "Vision framework and overall objectives of the future development of IMT-2000 and of systems beyond IMT-2000"
- [24] ITU-R WP8F PDNR M.IMT-SVC, "Framework of services for the future development of IMT-2000 and systems beyond"
- [25] 3GPP TR 21.902 (2003), "Evolution of 3GPP System"
- [26] 3GPP TS 23.221 (2002), "Architectural requirements"
- [27] 3GPP TS 29.002 (2004), "Mobile Application Part (MAP) specification"
- [28] IETF RFC 2003 (1996), "IP Encapsulation within IP"
- [29] IETF RFC 2004 (1996), "Minimal Encapsulation within IP"
- [30] IETF RFC 2005 (1996), "Applicability Statement for IP Mobility Support"
- [31] IETF RFC 2006 (1996), "The Definitions of Managed Objects for IP Mobility Support using SMIv2"
- [32] IETF RFC 2460 (1998), "Internet Protocol version 6 (IPv6) specification"
- [33] IETF RFC 2461 (1998), "Neighbor Discovery for IP version 6"
- [34] IETF RFC 2462 (1998), "IPv6 Stateless Address Autoconfiguration"
- [35] IETF RFC 2794 (2000), "Mobile IP Network Access Identifier Extension for IPv4"
- [36] IETF RFC 2960 (2000), "Stream Control Transmission Protocol"
- [37] IETF RFC 2977 (2000), "Mobile IP Authentication, Authorization, and Accounting Requirements"
- [38] IETF RFC 3012 (2000), "Mobile IP Challenge/Response Extensions"
- [39] IETF RFC 3024 (2001), "Reverse Tunneling for Mobile IP"
- [40] IETF RFC 3115 (2001), "Mobile IP Vendor/Organization-Specific Extensions"
- [41] IETF RFC 3257 (2002), "SCTP Applicability Statement"
- [42] IETF RFC 3261 (2002), "SIP: Session Initiation Protocol"
- [43] IETF RFC 3262 (2002), "SIP: Locating SIP Servers"

- [44] IETF RFC 3361, “DHCP Option for SIP Servers”
 - [45] IETF RFC 3344 (2002), “IP Mobility Support for IPv4”
 - [46] IETF RFC 3775 (2004), “Mobility Support in IPv6”
 - [47] IETF draft-ietf-mobileip-cellularip-00.txt (1999), “Cellular IP”
 - [48] IETF draft-ietf-tsvwg-addip-sctp-09.txt (2004), “Stream Control Transmission Protocol (SCTP) Dynamic Address Reconfiguration”
-