



INTERNATIONAL TELECOMMUNICATION UNION

**TELECOMMUNICATION
STANDARDIZATION SECTOR**

STUDY PERIOD 2001-2004

**NP-040018
COM 16 – LS 05 – E**

English only

Original: English

Question(s): F/16

Geneva, 20-30 January 2004

**LIAISON STATEMENT
(Ref.: TD 90/PLEN)**

Source: ITU-T SG 16

Title: Reply LS to SG 11 on Signalling Requirements for IP-QoS

To: ITU-T SG 11

CC:

ITU-T SG 2, Q.2/2; SG 9, Q.13/9; SG 12, Q.13/12; SG 13, Q.16/13 & Q.6/13 & Q.7/13; SSG, Q.6/SSG & Q.7/SSG;

ETSI (for 3GPP and TISPAN);

TIA (for 3GPP2)

Approval: Agreed during the SG 16 Meeting (20-30 January 2004)

For: Information

Deadline: NA

Contact:	Mike Buckley Telchemy, Inc. UK	Tel: +44 1457 820015 Fax: +44-1457-877721 E-mail: mikebuckley@44comms.com
-----------------	--------------------------------------	---

Contact:	Seong-Ho Jeong Korea	Tel: +82-31-330-4642 Fax: +82-31-333-4256 Email: shjeong@hufs.ac.kr
-----------------	-------------------------	---

Please don't change the structure of this table, just insert the necessary information.

Thank you for informing us of your intention to hold an electronic meeting to progress Signalling Requirements for IP-QoS. It was unfortunately not possible to discuss this at our last meeting and plan participation. However we would be pleased to participate in future similar meetings and remain committed to collaborating on this issue. We enclose a copy of new recommendation H.360 (ex-H.qos.arch), which we hope will assist in defining a framework for QoS signalling.

ATTACHMENT:

- [TD 76 \(PLEN\)](#) – Consented H.360 “An Architecture for End-to-End QoS Control and Signalling”

<p>Attention: Some or all of the material attached to this liaison statement may be subject to ITU copyright. In such a case this will be indicated in the individual document. Such a copyright does not prevent the use of the material for its intended purpose, but it prevents the reproduction of all or part of it in a publication without the authorization of ITU.</p>

Question(s): F/16

Geneva, 20-30 January 2004

TEMPORARY DOCUMENT

***Source:** Editor

Title: Draft New Recommendation H.qos.arch “An Architecture for End-to-End QoS Control and Signalling” (for Consent)

Summary

End-to-end quality of service (QoS) and service priority require co-ordination of resources and quality control mechanisms at all points in a multimedia system. Procedures for achieving this entail a combination of information flows and functionality at various levels in the system. This recommendation provides a reference architecture for defining and analysing mechanisms and procedures for achieving end-to-end QoS and service priority control.

Contact: Seong-Ho Jeong
HUFS/Samsung
Korea

Tel: +82-31-330-4642
Fax: +82-31-333-4256
Email shjeong@hufs.ac.kr

Attention: This is not a publication made available to the public, but an **internal ITU-T Document** intended only for use by the Member States of the ITU, by ITU-T Sector Members and Associates, and their respective staff and collaborators in their ITU related work. It shall not be made available to, and used by, any other persons or entities without the prior written consent of the ITU-T.

Table of Contents

1	Scope.....	4
2	References.....	4
3	Definitions	4
4	Abbreviations and Acronyms	6
5	Generic QoS Architecture.....	6
5.1	Functional Planes.....	6
5.1.1	MM Application Plane	7
5.1.2	Packet-Based Network Plane.....	7
5.1.3	Circuit-Switched Plane	7
5.1.4	Management Plane.....	7
5.2	Decomposition of MM Systems into Administrative Domains.....	7
5.2.1	End User Domains	7
5.2.2	Service Domains	7
5.2.3	Network Operator Domains.....	7
5.3	QoS Classification at Service, Application, and Network Levels	8
5.3.1	Service & Application Levels.....	8
5.3.1.1	QoS Service Classes	8
5.3.1.2	Priority Levels.....	9
5.3.1.3	Application Factors.....	9
5.3.2	Packet Based Network Level	9
5.3.2.1	QoS Traffic Classes	9
5.3.2.2	QoS Network Impairment Parameters	9
5.4	QoS Budgets	10
5.5	Functional Entities and Reference Points	10
5.5.1	Definition of Reference Points	11
5.5.2	Definition of Functional Entities	11
5.5.2.1	QoS Service Manager (QoSM).....	11
5.5.2.2	QoS Policy Entity (QoSPE).....	12
5.5.2.3	Transport Functionality (TF)	12
5.5.2.4	Network Policy Entity (NPE)	12
5.5.2.5	Resource Manager (RM).....	12
5.5.2.6	Interconnect Function (ICF).....	12
6	QoS Control and Signalling Procedures	12

6.1	General Framework	12
6.1.1	Option 1: ASP Controlled Inter-Domain Routing	13
6.1.1.1	ASP Control: Option 1a	13
6.1.1.2	ASP Control: Option 1b	13
6.1.2	Option 2: Network Operator Controlled Inter-Domain Routing	14
6.2	Classification of QoS Signalling Types	14
6.2.1	QoS Signalling Type 1 (QST 1)	14
6.2.2	QoS Signalling Type 2 (QST 2)	15
6.2.3	QoS Signalling Type 3 (QST 3)	15
6.2.4	QoS Signalling Type 4 (QST 4)	16
6.2.5	QoS Signalling Type 5 (QST 5)	16
6.3	QoS Signalling Procedures	17

ITU-T Draft New Recommendation H.qos.arch

An Architecture for End-to-End QoS Control and Signalling

Summary

End-to-end quality of service (QoS) and service priority require co-ordination of resources and quality control mechanisms at all points in a multimedia system. Procedures for achieving this entail a combination of information flows and functionality at various levels in the system. This recommendation provides a reference architecture for defining and analysing mechanisms and procedures for achieving end-to-end QoS and service priority control.

1 Scope

This Recommendation contains a reference architecture for controlling the QoS and service priority of multimedia services in networks which are comprised of combinations of switched circuit and packet domains, wireless and wireline technologies, and conventional and packet-based terminals. The reference architecture is functionally defined. This Recommendation uses a domain-based approach which allows issues of administrative control and security also to be considered.

This Recommendation is concerned with end-to-end QoS control in multimedia systems made up of multiple and disparate administrative domains and QoS mechanisms. Detailed mechanisms for generic QoS control in individual networks are not described here but may be found in ITU-T Y-series Recommendations.

2 References

- ITU-T Recommendation Y.1540 (2002), Internet protocol data communication service - IP packet transfer and availability performance parameters
- ITU-T Recommendation Y.1541 (2002), Network performance objectives for IP-based services
- ITU-T Recommendation G.1010 (2001), End-user multimedia QoS categories
- ITU-T Recommendation M.2301 (2002), Performance objectives and procedures for provisioning and maintenance of IP-based networks

3 Definitions

This Recommendation defines the following terms:

Application Service: A network-based service involving the transmission and/or processing of multimedia information.

Application Service Provider (ASP): A Service Provider providing Application Services.
Note: The same business entity may act as both Network Operator and Application Service Provider.

End User: An entity employing Application Services.

End User Domain (EUD): A collection of physical or functional entities, including terminal equipment and network resources under the control of an End User.

Interconnect Function (ICF) A functional entity that interconnects Network Operator Domains. It provides a policy and/or administrative boundary and may police authorised media flows between two Network Operator Domains to ensure they are consistent with the QoS policies of the Network Operator of that domain.

Network Operator: An administrative entity operating a network.

Network Operator Domain (NOD): A collection of network resources sharing a common set of policies, QoS mechanisms and technologies under the control of a Network Operator.

Network Policy Entity (NPE): A functional entity residing in a Network Operator Domain that maintains the policies of the Network Operator.

Quality-of-Service Manager (QoSM): A functional entity residing in a Service Domain that mediates requests for end-to-end QoS in accordance with policies of the Application Service Provider controlling the Service Domain. It communicates with other QoSMs and with TRMs to determine, establish and control QoS.

Quality-of-Service Policy Entity (QoSPE): A functional entity residing in a Service Domain that manages the QoS policies of the Application Service Provider controlling the Service Domain. It provides authorisation of permitted and default QoS levels. It receives requests from and issues responses to QoSMs to establish the authorised end-to-end QoS levels.

Service Domain (SD): A collection of physical or functional entities offering Application Services under the control of an Application Service Provider which share a consistent set of policies and common technologies.

Resource Manager (RM): A functional entity residing in a Network Operator Domain that applies a set of policies and mechanisms to transport resources within the domain to enable specified QoS levels to be achieved within the domain.

Transport Functionality (TF): A functional entity representing the collection of transport resources within a Network Operator Domain.

User Equipment (UE): Equipment under the control of an End User

4 Abbreviations and Acronyms

This Recommendation uses the following abbreviations:

ASP	Application Service Provider
COPS	Common Open Policy Service
DiffServ	Differentiated Services
EUD	End User Domain
ICF	Interconnect Function
IntServ	Integrated Services
MM	Multi Media
MPLS	Multi-Protocol Label Switching
NOD	Network Operator Domain
NPE	Network Policy Entity
QoS	Quality of Service
QoS M	Quality-of-Service Manager
QoS PE	Quality-of-Service Policy Element
QST	QoS Signalling Type
RM	Resource Manager
RSVP	Resource ReSerVation Protocol
SD	Service Domain
TF	Transport Functionality
UE	User Equipment

5 Generic QoS Architecture

5.1 Functional Planes

To achieve end-to-end QoS control in multi-media (MM) systems, the QoS mechanisms operating in the multi-media application must operate together with the QoS mechanisms operating in the packet-based network (e.g., RSVP, DiffServ, MPLS, etc.) which are generic and independent of the application. Furthermore, network management mechanisms may also be involved in controlling and managing QoS. Figure 1 illustrates the relationship between a number of functional planes within which QoS mechanisms reside.

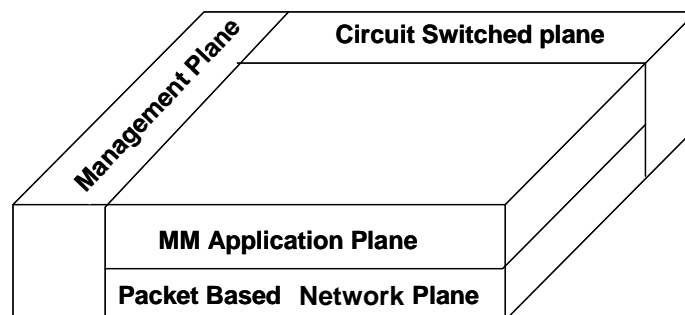

Figure 1 - Relationship between MM Application, Packet-Based Network, Management, and Circuit-Switched Planes

5.1.1 MM Application Plane

Within this plane, QoS parameters specific to the MM application (e.g., QoS service class) are requested, authorised, signalled, monitored, and controlled.

5.1.2 Packet-Based Network Plane

Within this plane, general non-application specific traffic parameters effecting QoS (e.g., end-to-end delay, delay variation (jitter), packet loss, and bandwidth) must be controlled and accounted to achieve the QoS requirements requested by the MM application. This plane may be based on IP, MPLS, or other technologies. With connection-oriented MPLS networks, it may be possible to support some QoS services with greater efficiencies than connectionless IP networks.

5.1.3 Circuit-Switched Plane

Within this plane, every call receives the same level of quality. Circuit-switched networks only provide a choice of call acceptance or non-acceptance depending upon the requested and available capacities. Once a call has been accepted, the capacity allocated is constant throughout the connection duration. Circuit-switched networks are engineered to provide acceptable quality levels for interactive communications. Transmission planning guidelines will determine the levels of quality achievable in circuit-switched environments.

5.1.4 Management Plane

Within this plane, QoS signalling statistics are exchanged with the MM Application Plane and Packet Based Network Plane. This signalling will include call statistics, network utilization information, network configuration, performance monitoring, and network resource allocation.

5.2 Decomposition of MM Systems into Administrative Domains

An MM system will in the general case be made up of a number of separate Administrative Domains, each representing the domain of control of an MM End-User, Application Service Provider or Network Operator.

5.2.1 End User Domains

An End User Domain is a collection of physical or functional entities, including terminal equipment and network resources under the control of an End User. The End User may be an individual or administrative entity employing Application Services.

5.2.2 Service Domains

A Service Domain is a collection of physical or functional entities offering Application Services under the control of an Application Service Provider which share a consistent set of policies and common technologies. An MM System will in the general case be made up of a number of separate Service Domains.

5.2.3 Network Operator Domains

A Network Operator Domain is a collection of network resources sharing a common set of policies, QoS mechanisms and technologies under the control of a Network Operator. An MM system will, in general, be made up of a number of separate Network Operator Domains. Network Operator Domains consist largely of transport-related functionality; this includes IP routers, ATM/MPLS switches, however may contain application-based elements such as NATs, firewalls, etc. Each Network Operator Domain may have its own QoS policies and/or differ from other domains in

terms of administrative control (e.g., Network Operator), QoS mechanisms (RSVP/IntServ, DiffServ, MPLS, etc.), access, metering, addressing schemes (global, local), network protocol (IPv4 or IPv6), etc.

5.3 QoS Classification at Service, Application, and Network Levels

A single application such as videoconferencing, telephony, or web browsing can be made of many unique media streams. To provide maximum flexibility and network optimisation not all media streams from one application have to be tagged with the same classifications. Each media stream of an application may be uniquely classified by a priority level as well as a QoS Service Class as shown in Figure 2.

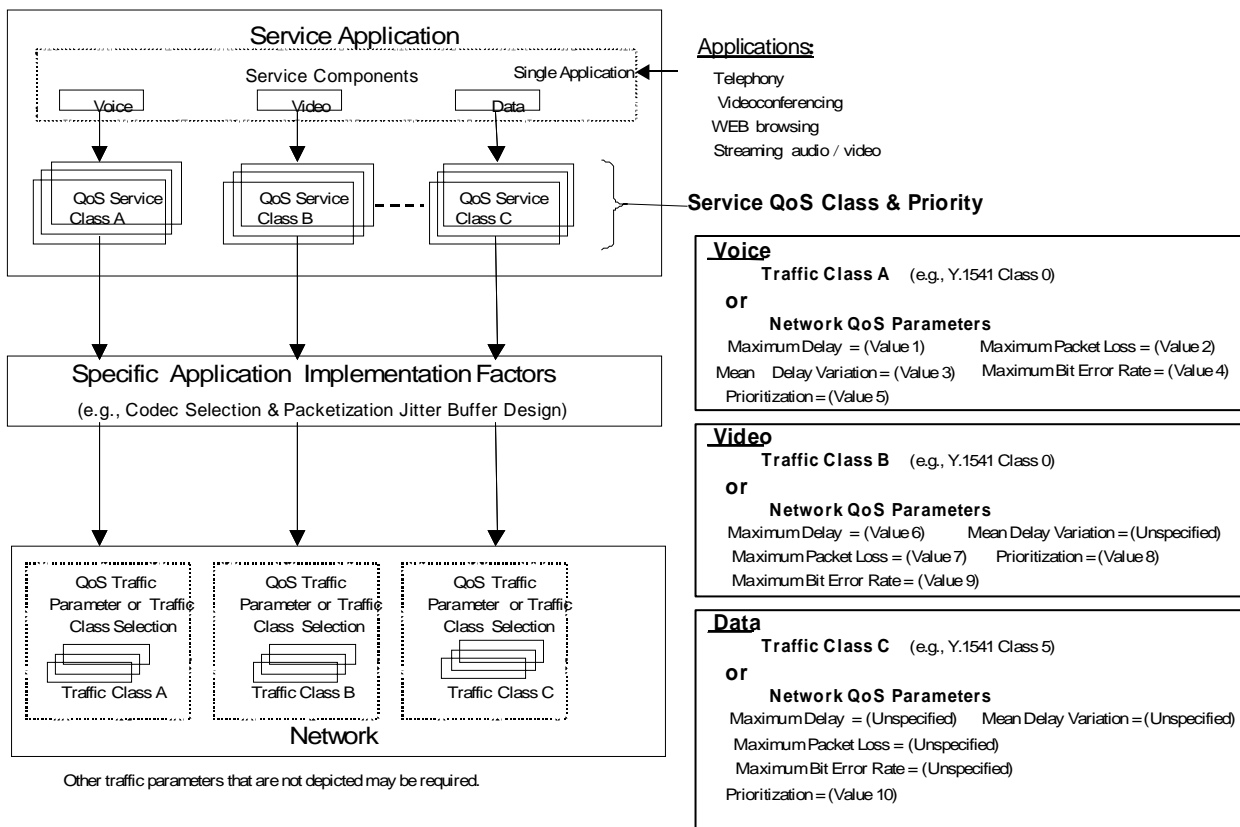

Figure 2 - QoS Classification at Service, Application, and Network Levels

5.3.1 Service & Application Levels

Any specific application can be broken down into multiple data streams. Each data stream or service component shall be classified into a QoS Service Class.

5.3.1.1 QoS Service Classes

When defining QoS service classes for multimedia applications, it may be useful to define these in terms of traffic characteristics required for different applications. ITU-T Recommendation G.1010 defines a number of multimedia application types in this way.

For a certain QoS service class, at least three parameters including delay, delay variation, and packet loss should have a defined value. For each QoS parameter, the values, when bounded, are restricted

on just one direction and can vary arbitrarily. For example, delay should not be larger than the agreed value, and IPDV in Y.1541 should not exceed the requested value. Note: the statistics of packet loss will need to be accurately defined in order to fully specify the performance of the packet based network. For example, there are two different types of packet losses: bursty and random packet losses. Two sets of statistics might be appropriate for characterization of bursty and random packet losses, and a clear definition of how to define the statistics is needed. This is for further study.

5.3.1.2 Priority Levels

To support service priority levels, it may be necessary to allocate network resources according to service priority levels. For example, a call with a high priority level can be treated preferentially by providing guaranteed network resources. Public or authorized emergency calls which need emergency service treatment can be given high priority levels. Even during times of congestion, such emergency calls should be allowed to use adequate network resources. To guarantee the use of adequate network resources for such high priority calls, it may be necessary to reserve a certain amount of buffer space in network elements such as IP routers or ATM/MPLS switches. The required buffer size can be determined by the agreed-upon traffic profile based on an agreement between a user and a service provider, and the reservation of buffer space can be achieved using a specific buffer occupancy threshold for a service class with a high priority level. To support multiple service priority levels (e.g., emergency calls, normal/best effort calls, etc.), resource allocation based on logical buffer partitioning may be used.

5.3.1.3 Application Factors

There are a number of implementation factors that determine the required QoS traffic classes or impairment parameters in the Packet Based Network Plane. These implementation factors should be chosen to optimise performance and will determine the specification of the required transport QoS classes or impairment parameters. For example, highly interactive speech with an MOS rating of 4.0 will require use of a G.711 codec or wideband codecs and will set tight bounds on end-to-end delay, delay variation (jitter), and packet loss.

5.3.2 Packet Based Network Level

Bounds must be placed on a number of impairment parameters to achieve the desired QoS Service Level. These bounds must be either specified numerically on a per-stream basis or may be selected from a number of predefined QoS traffic classes. ITU-T Recommendation Y.1541 specifies a number of such QoS traffic classes.

5.3.2.1 QoS Traffic Classes

Details of the recommended QoS traffic classes can be found in ITU-T Recommendation Y.1541.

5.3.2.2 QoS Network Impairment Parameters

The primary network parameters that impact QoS are:

- **End-to-End Delay:** End-to-end delay is the sum of the delays at the different network devices and across the network links through which multimedia traffic passes. End-to-end delay has a significant effect on the user's perception of the multimedia service.
- **Delay Variation (Jitter):** Delay variation is the variation in the inter-packet arrival time (leading to gaps, known as jitter, between packets) as introduced by the variable transmission delay over the network. Removing jitter requires collecting packets in buffers and holding them

long enough to allow the slowest packets to arrive in time to be played in correct sequence. Jitter buffers cause additional delay, which is used to remove the packet delay variation as each packet transits the network.

- **Packet Loss:** In general, IP-based networks do not guarantee delivery of packets. Packets will be dropped under peak loads and during periods of congestion. Note: in case of multimedia services, when a late packet finally arrives, it will be considered lost.

Definitions of these parameters are specified more fully in ITU-T Recommendation Y.1540.

5.4 QoS Budgets

To achieve the required end-to-end QoS for a particular media stream, mechanisms must exist within the system to ensure that the bounds on individual transport parameters, or the bounds implied by classification of the flow to a particular traffic class, are enforced across the system. The combined impairments introduced by all the Network Operator Domains in the system must be maintained within the specified bounds. This leads to the concept of an impairment budget for each domain traversed by the media flow. This is illustrated in Figure 3.

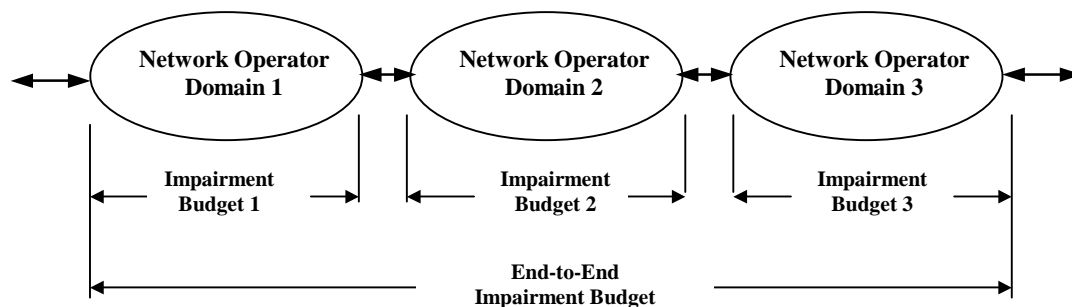

Figure 3 – End-to-End and Individual Network Operator Domain Impairment Budgets

Network planning rules, such as those specified in ITU-T Recommendation M.2301, may be used to ensure that the combined effects of impairments within each Network Operator Domain are within end-to-end budgets. Where such static provisioning is not practicable, the QoS control and signalling procedures detailed in Section 6 are intended to permit the signalling of individual impairment budgets to each Network Operator Domain traversed by the media flow. The algorithm and policies for allocating individual budgets to Network Operator Domains are outside the scope of this Recommendation.

5.5 Functional Entities and Reference Points

A number of Functional Entities within both Service and Network Operator Domains are defined as part of a generic end-to-end QoS control mechanism. The relationship between these Functional Entities is shown in Figure 4.

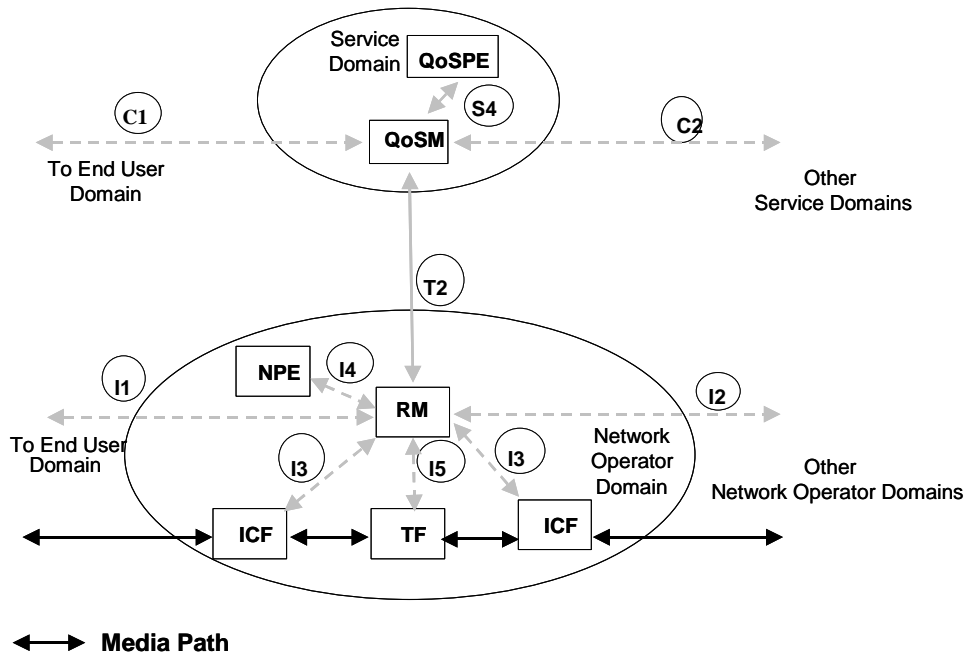

Figure 4 - Relationship between QoS Functional Entities

5.5.1 Definition of Reference Points

Reference points within a Network Operator Domain, between two Network Operator Domains, and between an End User Domain and a Network Operator Domain are labelled I. Reference points within a Service Domain are labelled S. Reference points between a Service Domain and a Network Operator Domain are labelled T. Reference points between two Service Domains, and between a Service Domain and an End User Domain are labelled C. The example reference points in Figure 4 are defined as follows:

- I1: the reference point between an End User Domain and a Network Operator Domain
- I2: the reference point between two Network Operator Domains
- I3: the reference point between a RM and an ICF within a Network Operator Domain
- I4: the reference point between a NPE and a RM within a Network Operator Domain
- I5: the reference point between a RM and a TF within a Network Operator Domain
- C1: the reference point between an End User Domain and a Service Domain
- C2: the reference point between two Service Domains
- S4: the reference point between a QoSM and a QoSPE within a Service Domain
- T2: the reference point between a Service Domain and a Network Operator Domain

5.5.2 Definition of Functional Entities

5.5.2.1 QoS Service Manager (QoSM)

The QoSM is a functional entity that mediates requests for end-to-end QoS in accordance with policy determined by the QoSPE. It communicates with other QoSMs and with RMs to determine, establish and control the offered QoS.

5.5.2.2 QoS Policy Entity (QoSPE)

The QoSPE is a functional entity that manages application policies and provides authorization of permitted and default QoS levels. It receives requests from and issues responses to QoSMs to establish the authorized end-to-end QoS levels.

5.5.2.3 Transport Functionality (TF)

The TF is a functional entity representing the collection of transport resources within a Network Operator Domain, which is capable of QoS control.

5.5.2.4 Network Policy Entity (NPE)

The NPE is a functional entity residing in a Network Operator Domain that maintains the policies of the Network Operator.

5.5.2.5 Resource Manager (RM)

The RM is a functional entity residing in a Network Operator Domain that applies a set of policies and mechanisms to transport resources within the domain to enable specified QoS levels to be achieved within the domain.

5.5.2.6 Interconnect Function (ICF)

The ICF is a functional entity that interconnects Network Operator Domains. It provides a policy and/or administrative boundary and may police authorised media flows between two Network Operator Domains to ensure they are consistent with the QoS policies of the Network Operator of that domain.

6 QoS Control and Signalling Procedures

6.1 General Framework

End-to-end QoS control is required to ensure that the desired QoS Service Class and Priority is achieved during an MM session. Each flow during a session may potentially have associated with it a different QoS Service Class and Priority so the mechanisms used must support this possibility. Furthermore, QoS control must be supported throughout the entire path that the media stream(s) traverses in order to achieve an end-to-end result.

The general case is illustrated in Figure 5. QoS control flows and media flows are shown separately. There are two primary options for end-to-end QoS control:

- Option 1 (Figure 5). Application Service Provider (ASP) Controlled Inter-Domain Routing involving QoS signalling between QoSMs, and between QoSMs and RMs.
- Option 2 (Figure 6). Network Operator Controlled Inter-Domain Routing involving QoS Signalling between RMs.

The detailed description of the signalling protocols used is outside the scope of this Recommendation.

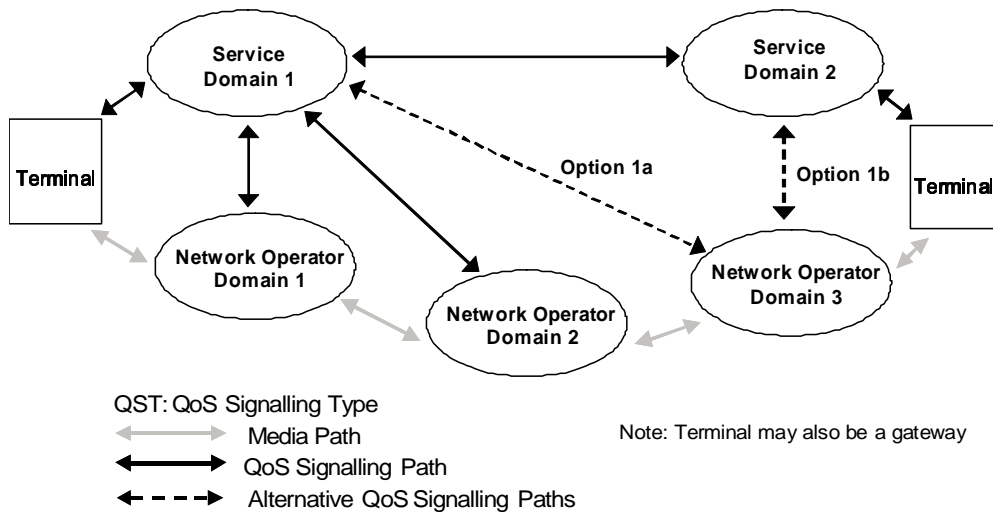

Figure 5 - Call involving Multiple Network Operator and Service Domains (Option 1)

6.1.1 Option 1: ASP Controlled Inter-Domain Routing

ASP Controlled Routing allows for the ASP initiating the call, possibly in conjunction with other ASPs, to select the sequence of Network Operators that will be involved in carrying the media flow. This arrangement permits a variety of business models involving multiple ASPs and multiple Network Operators. This option involves end-to-end QoS control signalling which takes place between Service Domains' QoSMs, and between a Service Domain's QoSM and a Network Operator Domain's RM. QoS Signalling to End User Domains is the responsibility of the initiating and terminating ASP.

6.1.1.1 ASP Control: Option 1a

In Option 1a, the entire end-to-end QoS control is with the initiating ASP. QoS control signalling takes place between the initiating ASP's QoSM and relevant RMs.

6.1.1.2 ASP Control: Option 1b

In Option 1b, the end-to-end QoS control is shared between the initiating ASP and other ASPs. QoS control signalling takes place between QoSMs of ASPs involved and relevant RMs.

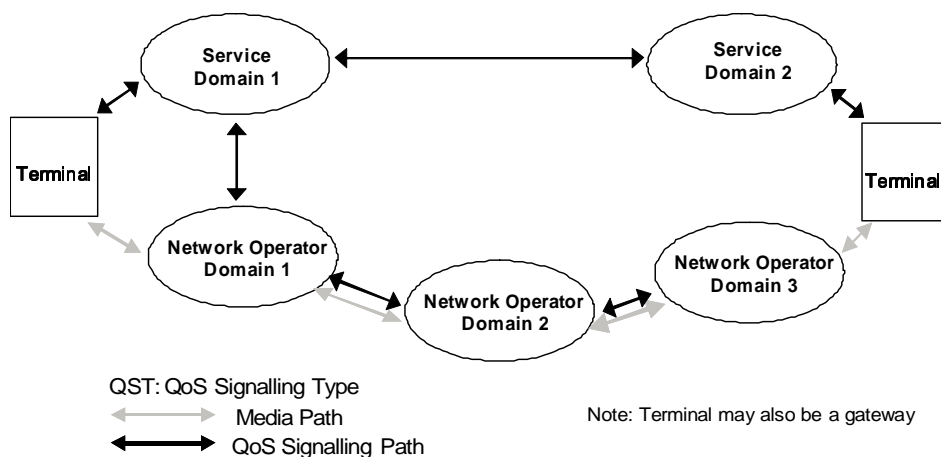

Figure 6 - Call involving multiple Network Operator and Service Domains (Option 2)

6.1.2 Option 2: Network Operator Controlled Inter-Domain Routing

With Network Operator Controlled Inter-Domain Routing, the selection of the sequence of Network Operators that will be involved in carrying the media flow lies with the Network Operators. This arrangement is the model which is most commonly used for circuit-switched networks. This option involves end-to-end QoS control signalling which takes place only between the initiating ASP and the first Network Operator. Signalling then takes place between Network Operator Domains' RMs to establish end-to-end QoS control. QoS Signalling to End User Domains, in general, will remain the responsibility of the initiating and terminating ASP.

6.2 Classification of QoS Signalling Types

QoS signalling can be classified into several QoS signalling types (QSTs) as shown in Figure 7.

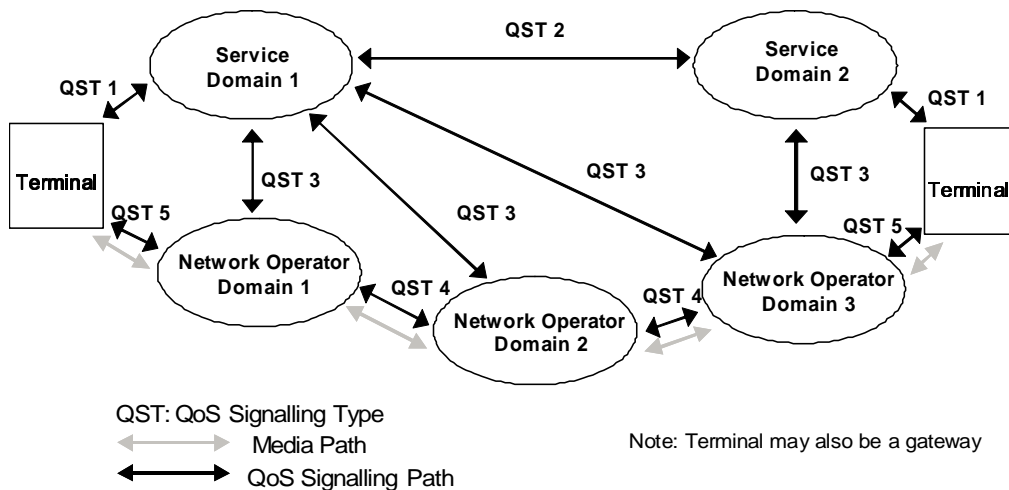

Figure 7 – QoS Signalling Types for Calls Involving Multiple Network Operator and Service Domains

6.2.1 QoS Signalling Type 1 (QST 1)

QST 1 describes QoS signalling between an End User and an ASP and corresponds to Reference Point C1. Figure 8 shows the functional relationships between the End User Domain, the (Access) Network Operator Domain, and Initiating Service Domain. A signalling protocol for QoS signalling initiation can be used at the application level in the End User and Service Domains. To initiate QoS signalling, the End User Domain first needs to communicate with the Initiating Service Domain via the (Access) Network Operator Domain.

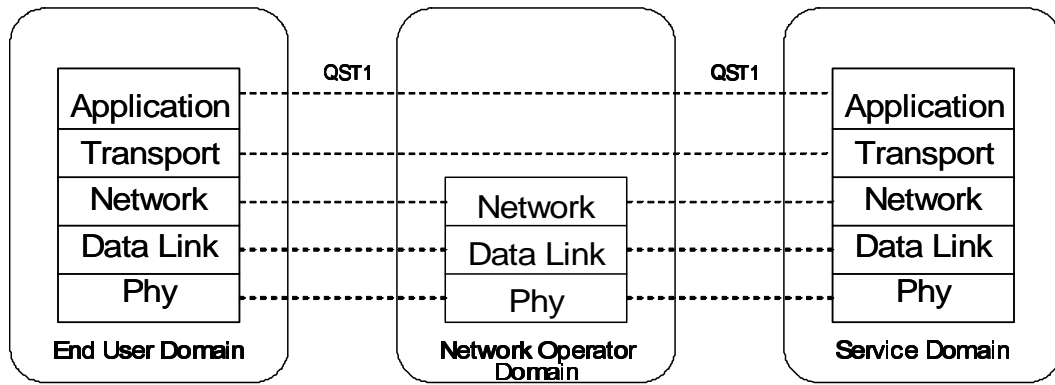

Figure 8 – Interactions between an End User Domain and a Service Domain via a Network Operator Domain

6.2.2 QoS Signalling Type 2 (QST 2)

QST 2 describes QoS signalling between two ASPs and corresponds to Reference Point C2. Figure 9 shows the functional relationships between two Service Domains and interconnecting Network Operator Domain(s). QoS signalling messages are exchanged between two Service Domains via the Network Operator Domain. A resource control function (e.g., QoSM, QoSPE, etc.) can be used at the application level in the Service Domain, and a policy protocol (e.g., COPS) can be used for policy decision in the Service Domain.

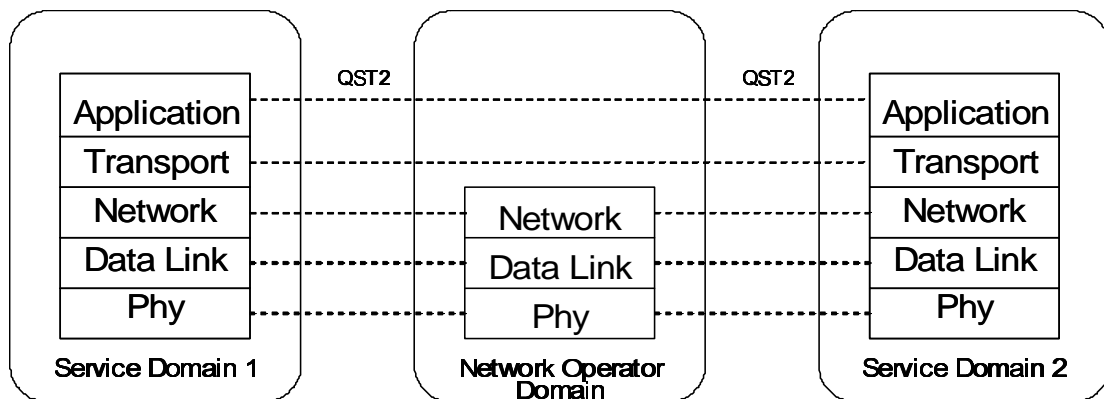

Figure 9 – Interactions between Service Domains via a Network Operator Domain

6.2.3 QoS Signalling Type 3 (QST 3)

QST 3 describes QoS signalling between an ASP and a Network Operator and corresponds to Reference Point T2. Figure 10 shows functional relationships between a Service Domain and a Network Operator Domain. The Service Domain needs to communicate with the Network Operator Domain for the reservation of necessary network resources. In Figure 10, different QoS technologies, for example, RSVP/IntServ, DiffServ, MPLS, etc., can be used at the network level in the Network Operator Domain, and a resource control function (e.g., QoSM, QoSPE, etc.) can be used at the application level in the Service Domain. A policy protocol, for example, COPS, can be used for policy decision and enforcement in the Service and Network Operator Domains. Various QoS technologies, for example, IEEE 802.1p, may also be used at the Data Link level in the Network

Operator Domain. All these technologies need to work cooperatively in various strategies to enable end-to-end QoS.

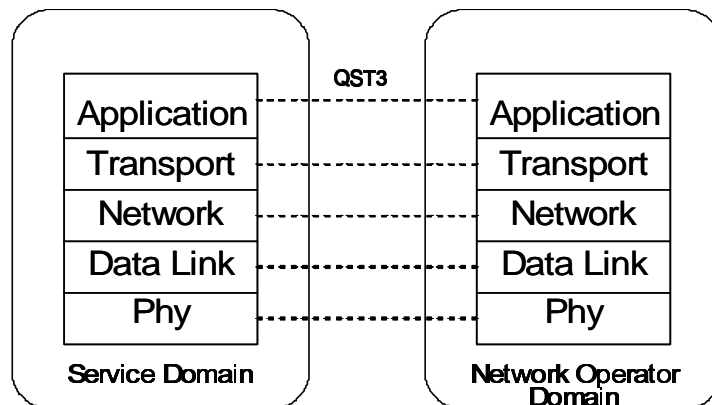

Figure 10 – Interactions between a Network Operator Domain and a Service Domain

6.2.4 QoS Signalling Type 4 (QST 4)

QST 4 describes QoS signalling between two Network Operators and corresponds to Reference Point I2. Figure 11 shows the functional relationships between two Network Operator Domains. Different QoS technologies, for example, RSVP/IntServ, DiffServ, MPLS, etc., can be used at the network level in the Network Operator Domain. Various QoS technologies, for example, IEEE 802.1p, may also be used at the Data Link level in the Network Operator Domain.

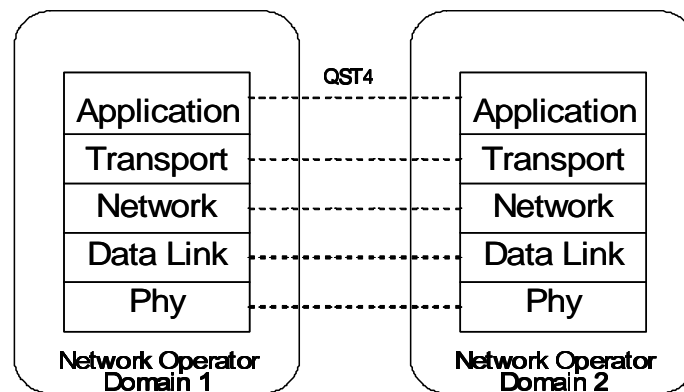

Figure 11 – Interactions between Network Operator Domains

6.2.5 QoS Signalling Type 5 (QST 5)

QST 5 describes QoS signalling between an End User and a Network Operator and corresponds to Reference Point I1. Figure 12 shows the functional relationships between an End User Domain and a Network Operator Domain. The End User Domain may communicate with the Network Operator Domain for the reservation of necessary transport resources. In this case, the Service Domain should be involved in the authorization of communication between the End User Domain and the Network Operator Domain.

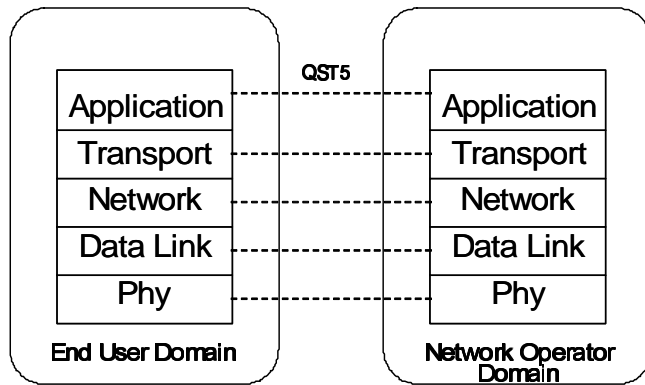

Figure 12 – Interactions between an End User Domain and a Network Operator Domain

6.3 QoS Signalling Procedures

Figures 13 – 15 illustrate the procedures for establishing end-to-end QoS control for an MM application. The QoS signalling may be independent of call or media stream establishment or control signalling or be combined with either of these. In the figures, the signalling required to reserve the necessary resources along the media path is shown. Additional signalling is required to confirm the resource reservation after the reservation phase. This is not shown in the diagrams.

- Option 1a

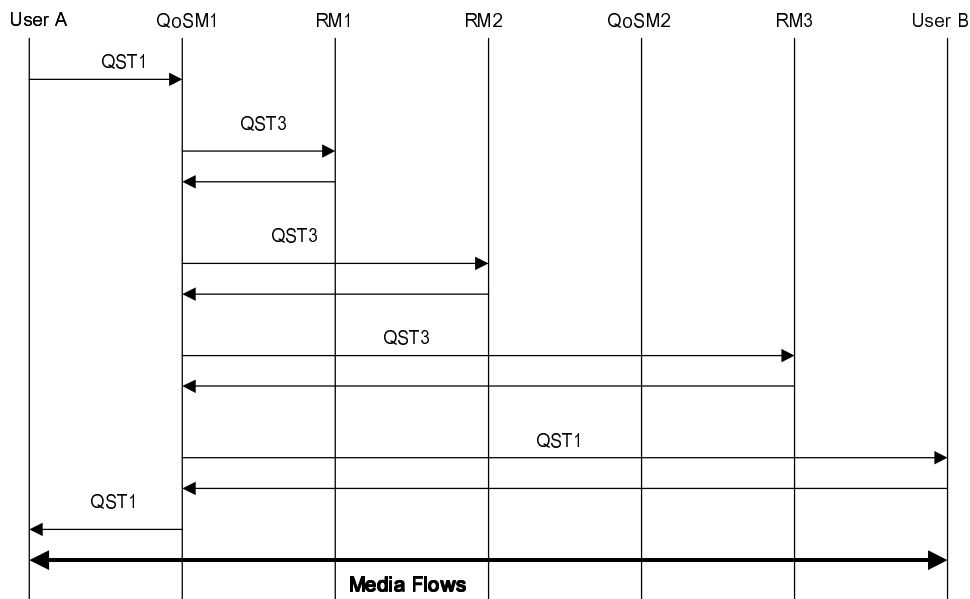

Figure 13 –QoS Signalling Option 1a

- Option 1b

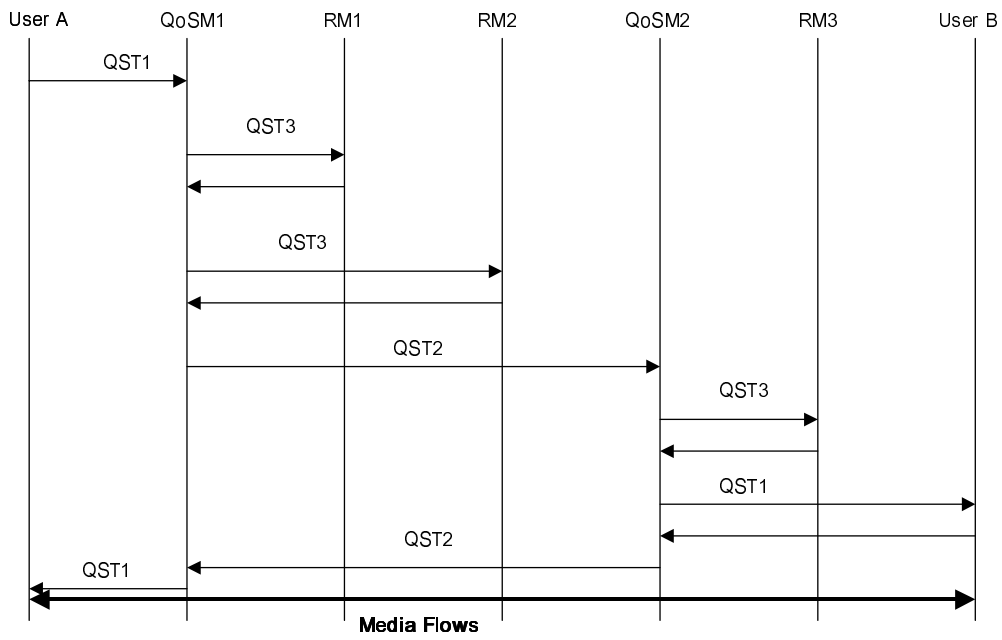

Figure 14 –QoS Signalling Option 1b

- Option 2

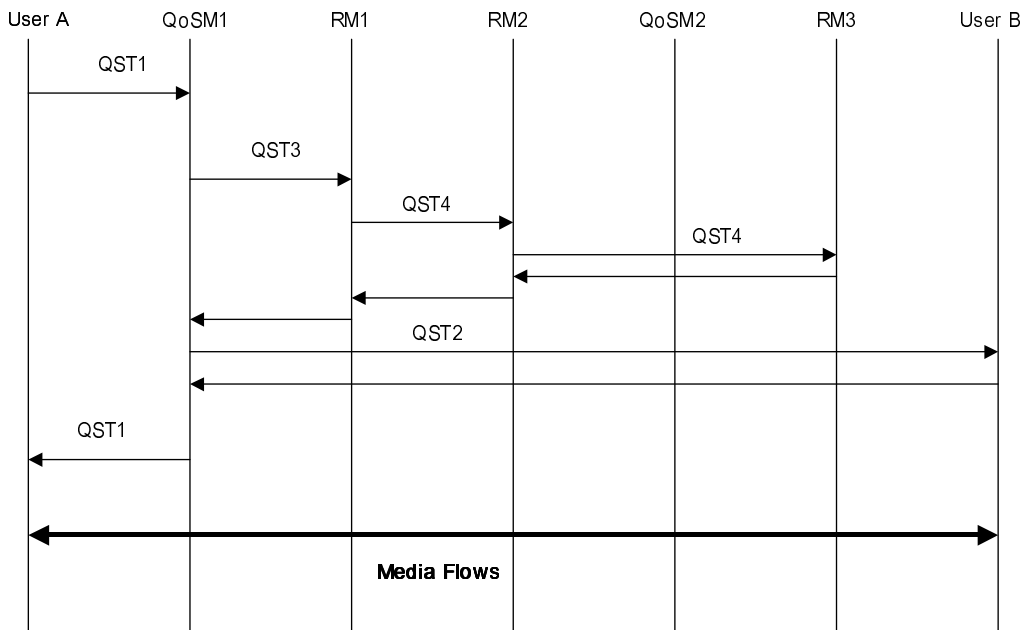

Figure 15 – QoS Signalling Option 2