

Overview of 3GPP Release 99

Summary of all Release 99 Features

v.1.0

**DRAFT FOR PRESENTATION AT TSG # 22
For ‘high-level’ review¹**

¹ Comments to be provided only on missing/incorrect Features. Comments should be addressed to alain.sultan@etsi.org with the following subject: “Comment to the REL-99 document”.

Credits

This document has been produced by the technical staff of ETSI MCC department, headed by Adrian Scrase, namely: Adrian Zoicas, Alain Sultan, Andrijana Jurisic, Cesar Gutierrez, Claude Arzelier (coordinator of the RAN aspects), David Boswarthick, Friedhelm Rodermund, John Meredith, Joern Krause, Kimmo Kymalainen, Michael Clayton, Paolo Usai, Per Johan Jorgensen, as well as Gert Thomasen, Tsukasa Sasaki, Claus Dietze, Maurice Pope and Sang Ui Yoon. The work was coordinated by Alain Sultan, who wishes to acknowledge all contributors for the high quality of their inputs.

Table of Content

1	INTRODUCTION	8
1.1	SCOPE	8
1.2	REFERENCES.....	8
1.2.1	<i>Specifications</i>	8
1.2.2	<i>Tdocs</i>	8
1.2.3	<i>Change Request database</i>	9
	PART 1 – UMTS FEATURES	10
2	ARCHITECTURE OF THE GSM-UMTS PLATFORM	10
3	THE UMTS TERRESTRIAL RADIO ACCESS NETWORK (UTRAN)	13
4	MANDATORY SPEECH CODEC FOR NARROWBAND TELEPHONY SERVICE	18
4.1	AMR - NS (NOISE SUPPRESSION).....	20
5	CODEC FOR LOW BITRATE MULTIMEDIA TELEPHONY SERVICE (H.324 M)	20
6	3G AUDIO-VISUAL TERMINAL CHARACTERISTICS	21
7	QUALITY OF SERVICE (QOS)	22
	PART 2 – UMTS AND GSM FEATURES	24
8	LOCATION SERVICES (LCS)	24
9	CAMEL PHASE 3	26
10	MULTIMEDIA MESSAGING SERVICE (MMS)	27
11	MULTIPLE SUBSCRIBER PROFILE (MSP) BASED ON CAMEL PH. 3	27
12	SHORT MESSAGE SERVICE (SMS) ENHANCEMENTS	28
13	MOBILE STATION EXECUTION ENVIRONMENT (MEXE)	28
14	MULTICALL	29
15	OPEN SERVICE ARCHITECTURE (OSA)	30
16	BILLING & CHARGING	31
17	OPERATIONS, ADMINISTRATION, MAINTENANCE AND PROVISIONING (OAM&P)	31
18	SUPER CHARGER	32
19	FOLLOW ME	34
20	ELECTRICAL SAFETY REQUIREMENTS AND REGULATIONS	35
21	MULTI-MODE UE ISSUES	35
22	SPECIFIC ABSORPTION RATE (SAR) REQUIREMENTS AND REGULATIONS IN DIFFERENT REGIONS	36

23	SYNCHRONISATION & OBJECT EXCHANGE	36
24	USER EQUIPMENT CAPABILITY REQUIREMENTS	36
25	TERMINAL INTERFACES	37
25.1	TERMINAL INTERFACES (AT COMMANDS FOR 3GPP).....	37
25.2	TERMINAL INTERFACES (PHYSICAL INTERFACES).....	37
25.3	TERMINAL INTERFACES (MULTIPLEXER).....	38
26	CIRCUIT SWITCHED BEARER SERVICES	38
27	FRAME TUNNELLING MODE (FTM)	39
28	ACCESS TO ISPS AND INTRANETS – WIRELESS/REMOTE ACCESS TO LANS	39
PART 3 – GSM FEATURES		41
29	THE DUAL TRANSFER MODE WITHIN GSM/GPRS	41
30	GENERAL PACKET RADIO SERVICE (GPRS) - RADIO PART	42
31	GSM ON 400 MHZ FREQUENCY BAND	42
32	ENHANCED DATA RATES FOR GSM EVOLUTION (EDGE)	44
32.1.1	<i>Phase 1 EDGE</i>	45
32.1.2	<i>Phase 2 EDGE</i>	45
33	ENHANCED GPRS (EGPRS)	45
34	GSM MOBILE NUMBER PORTABILITY EURO MNP/ NORTH AMERICAN MNP	47
35	ENHANCED CIRCUIT SWITCHED DATA (ECSD)	48
PART 4 - WIS APPLICABLE TO OTHER SYSTEM(S)		50
36	EDGE COMPACT	50
37	GPRS PHASE 2 FOR PCS1900	51
38	SUPPORT FOR EGPRS IN ANSI-136 NETWORKS	51
39	PHS INTERNET ACCESS FORUM SPECIFICATION (PIAFS)	52
PART 5 - FEATURES WITH NO IMPACT OR MINOR IMPACT ON THE SYSTEM		53
40	CELL BROADCAST SERVICE	53
41	SUPPORT OF LOCALIZED SERVICE AREA	53
42	AUTOMATIC ESTABLISHMENT OF ROAMING RELATIONS	53
43	ADVANCED ADDRESSING	54
44	QOS FOR SPEECH AND MULTIMEDIA CODEC	56
45	UMTS NUMBERING, ADDRESSING AND IDENTITIES	57

46	CC IMPROVEMENTS	57
47	L3 SEGMENTATION	57
48	SEPARATION OF RADIO RESOURCE AND MOBILITY MANAGEMENT SPECIFIC PARTS OF THE MOBILE SATION CLASSMARK	57
49	IDLE MODE CLASSMARK	57
50	FEASIBILITY STUDIES	58
50.1	CAMEL CONTROL OF VOIP SERVICES - FEASIBILITY STUDY.....	58
50.2	GATEWAY LOCATION REGISTER (GLR) - FEASIBILITY STUDY	58
50.3	STUDY ON COMBINED GSM AND MOBILE IP MOBILITY HANDLING IN UMTS IP CN	58
50.4	STUDY ON PROVISION OF FACSIMILE SERVICES IN GSM AND UMTS	58
50.5	TURBO-CHARGER: FEASIBILITY STUDY.....	58
PART 6 - FEATURES REMOVED FROM REL99		59
51	FEATURES REMOVED FROM REL99	59
51.1	CONNECTING AN OCTET STREAM TO A PORT ON AN INTERNET HOST	59
51.2	UNSTRUCTURED OCTET STREAM GPRS PDP TYPE	59
51.3	GPRS - POINT-TO-MULTIPOINT SERVICES.....	59
51.4	MODEM AND ISDN INTERWORKING FOR GPRS	59
51.5	REAL TIME FAX	59
51.6	HIGH SPEED CIRCUIT SWITCHED DATA	59
51.7	PROVISION OF TEXT TELEPHONY SERVICE IN GSM AND UMTS.....	59
51.8	SUPPORT FOR REAL TIME SERVICES IN THE PACKET DOMAIN FOR GSM/GPRS/UMTS R99	59
51.9	UMTS CORE BASED ON ATM TRANSPORT	59
51.10	IP-IN-IP TUNNELING IN GPRS BACKBONE FOR UMTS, PHASE 1.....	59
51.11	LAPDM PERFORMANCE ENHANCEMENT	59
51.12	TANDEM FREE OPERATION (TFO) IN 3G SYSTEMS AND BETWEEN 2G AND 3G SYSTEMS	60
51.13	NETWORK ASSISTED CELL CHANGE	60
51.14	INTERWORKING WITH MOBILE SATELLITE SYSTEMS.....	60
51.15	MS ANTENNA TEST METHOD	60
51.16	TANDEM FREE OPERATION (TFO) OF SPEECH CODECS IN MOBILE-TO-MOBILE CALLS (MMCs) (GSM 10.53)	60
51.17	OUT-OF-BAND TRANSCODER CONTROL	60
51.18	MS PROTOCOL/RF/EMC CONFORMANCE SPECIFICATION	60
51.19	THE CTS (CORDLESS TELEPHONY SYSTEM).....	60
51.20	SoLSA (SUPPORT OF LOCALISED SERVICE AREA).....	60
51.21	HARMONISED STANDARD UNDER R&TTE DIRECTIVE.....	60
LAST PART – UNSOLVED YET		61
52	UNSOLVED YET	61
52.1	MS AND NETWORK-RESIDENT EXECUTION ENVIRONMENTS (MS/N-RExE)	61
52.2	CALL FORWARDING ENHANCEMENTS (CFE).....	61
52.3	UNSTRUCTURED SUPPLEMENTARY SERVICE DATA (USSD) ENHANCEMENTS.....	61
52.4	ACCESS TO ISPs AND INTRANETS IN GPRS PHASE 2 – SEPARATION OF GPRS BEARER ESTABLISHMENT AND ISP SERVICE ENVIRONMENT SETUP.....	61
52.5	GENERIC SIGNALLING MECHANISM FOR SERVICE SUPPORT	61
52.6	IMPACT OF TELECOMMUNICATIONS DATA PROTECTION DIRECTIVE ON GSM STANDARDS	61
52.7	SERVICE TO GSM HANDPORTABLES IN TRAINS.....	61
53	STILL TO BE WRITTEN (BY MCC SA3 SUPPORT)	62
53.1	FRAUD INFORMATION GATHERING SERVICE (FIGS)	62

53.2	IMMEDIATE SERVICE TERMINATION (IST).....	62
53.3	FRAUD INFORMATION GATHERING SYSTEM APPLIED TO GPRS.....	62
53.4	IMMEDIATE SERVICE TERMINATION (IST) : CAMEL FREE SOLUTION.....	62
53.5	LAWFUL INTERCEPTION (LI)	62
53.6	SS7 SECURITY - INTEGRITY CHECKING.....	62
54	STILL TO BE WRITTEN (BY MCC T3 SUPPORT).....	62
54.1	DISPLAY OF SERVICE PROVIDER (SP) NAME BY THE MOBILE EQUIPMENT (ME).....	62
54.2	GSM-API FOR SIM-TOOLKIT	62
54.3	SIM TOOLKIT TEST SPECIFICATION	62
54.4	SPECIFICATION OF A BEARER INDEPENDENT PROTOCOL FOR SAT APPLICATIONS TO EXCHANGE DATA OVER THE GSM NETWORK	62
54.5	GENERIC LOGICAL AND PHYSICAL SPECIFICATION FOR IC CARD AND TERMINAL INTERFACE	62
54.6	SPECIFICATION OF ADMINISTRATIVE COMMANDS AND FUNCTIONS FOR IC CARDS.....	62
54.7	WAP WAE USER AGENT / SIM TOOLKIT INTERWORKING	62

1 Introduction

1.1 Scope

This document contains a high-level description of the Release 99 Features. It is part of a series of documents developed by MCC to provide a complete overview of the technical content of each Release.

A Feature is defined as new or substantially enhanced functionality which represents added value to the existing system. A feature should normally embody an improved service to the customer and / or increased revenue generation potential to the supplier.

Features are as independent as possible from each other, and relationships between features (if any) are clarified here.

The definition of Feature was introduced in Release 4, i.e. in the Release following Release 99. For elaborating this document, MCC has applied the “feature” concept to the work done in the release 99 time frame, so the “Release 99 Features” were not officially defined as such by 3GPP but are introduced for first time in this document. Also, the use of the 3GPP Work Plan was introduced in Release 4, i.e. there was no official tracking of the work progress in Release 99, so this document was written from a detailed review of all specifications, change requests, etc.

The features have been grouped in different parts: UMTS only features, GSM and UMTS features, GSM only features, features applicable to other system(s), and features with no impact or minor impact on the system [and UNSOLVED YET].

For each feature (or independent item), references are given to guide the reader on how to deepen the subject: the Work Item Description (WID) as well as the list of impacted specifications are provided in the beginning of the section describing the feature. Only the list of impacted specifications is provided here. The exact impact on a given specification due to a given feature is described in the Change Request (CR) list, which can be found at the end of the specification, or the CR database provides the full list of CRs for all 3GPP specifications.

The second part of this introduction contains global references, and provides links towards the 3GPP Specifications, the temporary documents (tdocs), the Work Item Descriptions (WIDs) and the CR database.

The main body of this document is structured according to the 3GPP Release 99 Features: each chapter corresponds to one Release 99 Feature.

1.2 References

1.2.1 Specifications

Global information on the Specifications (also called “specs”) can be found at:

<http://www.3gpp.org/specs/specs.htm>

The latest versions of all 3GPP specifications, containing the most recent corrections and additions, are available at:

<http://www.3gpp.org/ftp/Specs/latest/>

For specific purposes, older versions might be needed. These versions are available at:

<http://www.3gpp.org/ftp/Specs/Archive/>

where the specifications are sorted by series and then by folders containing all the available versions of a given spec (one folder per spec), for all Releases.

1.2.2 Tdocs

The Temporary Documents (tdocs) are mainly the original papers written by the 3GPP Members, and are the inputs for elaborating the specs. They are available (sorted by 3GPP technical groups (Technical Specification Groups (TSGs) and Working Groups (WGs)) at:

<http://www.3gpp.org/ftp/>

starting with 'tsg...!'.

1.2.3 Change Request database

A specification is originally drafted and maintained by a rapporteur, who compiles the contents from discussions in the WGs and TSGs. When it is considered to be 80% complete, it is brought under a so-called "change control" process. After this, changes to the specification can only be made using Change Requests that are usually agreed by consensus in the Working Group responsible for the specification, but then formally approved by the relevant Technical Specification Group².

The Change Request database contains all available information on Change Requests, including a Work Item code, a Change Request number that is unique within the specification (different versions are possible, but only one can ever be approved), the status of each Change Request and references to relevant temporary document numbers and meetings. This database is available in:

http://www.3gpp.org/ftp/Information/Databases/Change_Request/

Further information on CR is available at:

<http://www.3gpp.org/specs/CR.htm>

² For a complete description on the handling of Specs and CRs at 3GPP, see the presentation in:
http://www.3gpp.org/MCC/procedures/The_change_control_cycle.ppt

Part 1 – UMTS Features

2 Architecture of the GSM-UMTS Platform

Acronym: no acronym

References for WI " Architecture of the GSM-UMTS Platform "	
Document	Title/Contents
□	WI Sheet
Impacted Specifications	
TS 23.002	Network architecture
TS 23.060	General Packet Radio Service Service description; Stage 2
TS 23.008	Organisation of subscriber data
New Dedicated Specifications	
TS 23.101	General UMTS Architecture
TS 23.110	UMTS Access Stratum Services and Functions

UMTS (Universal Mobile Telecommunication System) refers to the interconnection of a new type of Access Network (AN), the UTRAN (UMTS Terrestrial Access Network) to the existing GSM/GPRS Core Network (CN) infrastructure. The UTRAN offers the new bearer services described in the next section.

A basic requirement on Release 99 UMTS was that the introduction of the UTRAN had to minimise the impacts on the Core Network. This principle was achieved to a great extent. However, the impacts were not null, as shown in this section: a new type of interface is created between core and access networks, the signalling is upgraded to take into account the new capabilities offered by the UTRAN, etc.

This section describes the UMTS network, using a top-down approach. The biggest cut is the concept of “domains” for the physical aspect and of “strata” for the protocol aspects. These cutting principles, introduced for first time for UMTS, could also apply to GSM as well and to whatever type of network. They were established mainly to organise the work as to allow different groups of people to work in parallel, each one being responsible for a (set of) domain(s) and/or stratum(a).

The domains are:

- the User Equipment domain, containing the elements the end-user carries with him, composed of:
 - o the Mobile Equipment domain (the “phone”), containing the radio transmitting device (in the Mobile Termination, MT) and the application (in the Terminal Equipment, TE), defined by 3GPP T2 group, and
 - o the USIM domain, typically embedded in an IC card, defined by 3GPP T3 group.
- the Infrastructure domain, i.e. the set of all the network entities, composed of:
 - o the Access Network domain, comprising all the entities closely related to the radio technology, defined by 3GPP RAN1 to RAN4 groups and
 - o the Core Network domain, defined by 3GPP CN1 to CN4 groups, composed of:
 - the Serving Network domain, composed of
 - the Circuit Switched (CS) domain
 - the Packet Switched (PS) domain
 - the Transit Network domain (potentially composed of CS and PS also), and
 - the Home Network domain, containing permanently all the user specific data and responsible for management of subscription information.

The domains are shown in the following figure:

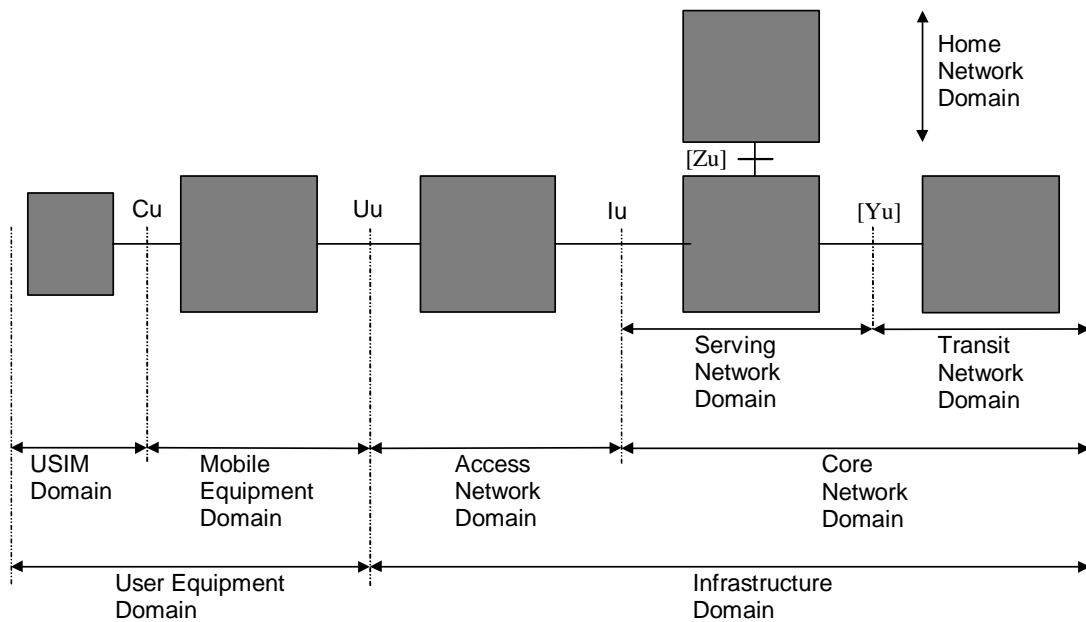

UMTS domains and reference points (the radio interface is Uu)

The strata are:

- the Transport stratum, supporting the transport of user data and network control signalling from other strata through UMTS. It encompasses the Access Stratum, which is the part of the transport stratum located between the edge node of the serving core network domain and the MT.
- the Home stratum, which contains the protocols and functions related to the handling and storage of subscription data and possibly home network specific services.
- the Serving stratum, which consists of protocols and functions to route and transmit data/information, user or network generated, from source to destination, and
- the Application stratum, which represents the application process itself, provided to the end-user. It includes end-to-end protocols and functions which make use of services provided by the home, serving and transport strata and infrastructure to support services and/or value added services.

The connection between domains is a network interface or a reference point³, the connection between strata is a service primitive or whatever process internal to a network node, subject or not to standardisation. Further definition of the domains and strata as well as their relationship is given in TS 23.101.

The next step in the network description is the cut in “entities” and “protocols”: a domain is a group of (potentially one) entity(ies), a stratum is a group of (potentially one) protocol(s) or contains the application data for the specific case of the Application Stratum.

UMTS introduces new entities⁴ in the AN -all the UTRAN entities are new, as described in the corresponding section- but not in the CN. The connection between entities is network interface or reference point. The following figure, extracted from 23.002, shows the UMTS and GSM Network Architecture.

³ “network interface” refers to a physical interface whereas a “reference point” can be physically composed of zero, one or several physical interface(s), as e.g. the Iu, which is a reference point composed of the Iu_CS and the Iu_PS interfaces.

⁴ With respect to entities definition, the standard assumes that an entity performs a given (set of) function(s) and offers a given (set of) interface(s) but the entity can also be further split into a group of non-standardised “smaller” entities, as long as the external interfaces are compliant to the ones defined in the standard.

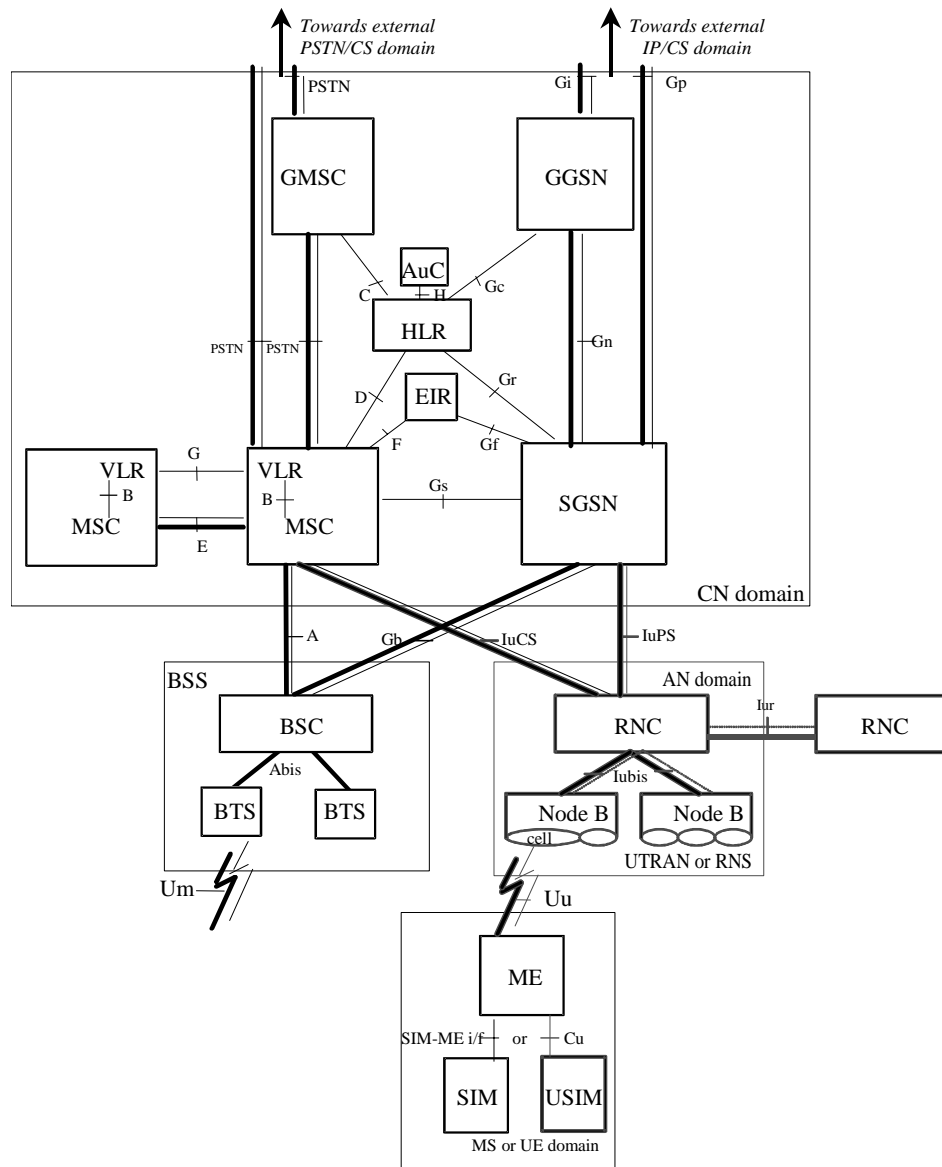

UMTS and GSM Network Architecture

Legend:

- Bold lines:** interfaces supporting user traffic;
- Dashed/thin lines:** interfaces supporting signalling.
- Red lines and boxes:** interfaces and entities specific to UMTS

With respect to protocols, again new protocols are introduced for the UTRAN (see corresponding section) but not for the CN, where the impacts are limited to modifications to the existing protocols, the most impacted one being MAP.

The functions performed by the UTRAN are different compared to the GSM BSS, in particular for the PS domain, so the nature of the interface between the CN and the AN is also different. The split of functions between CN and UTRAN, and a description of the transport services expected to be provided by the UTRAN to the rest of the network, are subject to a dedicated specification, 23.110. In CS domain, the changes between GSM and UMTS are not particularly relevant (GSM's A interface is quite similar to the UMTS' Iu_CS interface) whereas in PS domain, the UMTS' Iu_PS offers "connections" (called "Iu Bearers") contrarily to GSM's Gb interface. This is an important milestone for enabling future support of end-to-end Quality of Service in PS domain, although not supported in this Release.

3 The UMTS Terrestrial radio access network (UTRAN)

Affected specifications:

References for WI " UMTS Terrestrial radio access network (UTRAN)"	
Document	Title/Contents
	WI Sheet
	Impacted Specifications
New Dedicated Specifications	
UTRAN layer 1 (RAN1)	
TS 25.201	Physical layer - general description
TS 25.211	Physical channels and mapping of transport channels onto physical channels (FDD)
TS 25.212	Multiplexing and channel coding (FDD)
TS 25.213	Spreading and modulation (FDD)
TS 25.214	Physical layer procedures (FDD)
TS 25.215	Physical layer; Measurements (FDD)
TS 25.221	Physical channels and mapping of transport channels onto physical channels (TDD)
TS 25.222	Multiplexing and channel coding (TDD)
TS 25.223	Spreading and modulation (TDD)
TS 25.224	Physical layer procedures (TDD)
TS 25.225	Physical layer; Measurements (TDD)
TR 25.944	Channel coding and multiplexing examples
UTRAN layer 2 and layer 3 Radio Resource (RAN2)	
TS 25.301	Radio Interface Protocol Architecture
TS 25.302	Services provided by the physical layer
TS 25.303	Interlayer procedures in Connected Mode
TS 25.304	User Equipment (UE) procedures in idle mode and procedures for cell reselection in connected mode
TS 25.305	User Equipment (UE) positioning in Universal Terrestrial Radio Access Network (UTRAN); Stage 2
TS 25.306	UE Radio Access capabilities definition
TS 25.307	Requirements on UEs supporting a release-independent frequency band
TS 25.321	Medium Access Control (MAC) protocol specification
TS 25.322	Radio Link Control (RLC) protocol specification
TS 25.323	Packet Data Convergence Protocol (PDCP) specification
TS 25.324	Broadcast/Multicast Control (BMC)
TS 25.331	Radio Resource Control (RRC) protocol specification
TR 25.921	Guidelines and principles for protocol description and error handling
TR 25.922	Radio Resource Management Strategies
TR 25.993	Typical examples of Radio Access Bearers (RABs) and Radio Bearers (RBs) supported by Universal Terrestrial Radio Access (UTRA)
TR 25.925	Radio Interface for Broadcast/Multicast Services
TS 34.109	Terminal logical test interface; Special conformance testing functions
UTRAN interfaces (RAN3)	
TS 25.401	UTRAN Overall Description
TS 25.402	Synchronisation in UTRAN Stage 2
TS 25.410	UTRAN Iu Interface: General Aspects and Principles
TS 25.411	UTRAN Iu Interface Layer 1
TS 25.412	UTRAN Iu Interface Signalling Transport
TS 25.413	UTRAN Iu Interface RANAP Signalling
TS 25.414	UTRAN Iu interface data transport and transport signalling
TS 25.415	UTRAN Iu interface user plane protocols
TS 25.419	UTRAN Iu-BC interface: Service Area Broadcast Protocol (SABP)
TS 25.420	UTRAN Iur Interface General Aspects and Principles
TS 25.421	UTRAN Iur interface layer 1

TS 25.422	UTRAN Iur Interface Signalling Transport
TS 25.423	UTRAN Iur interface RNSAP signalling
TS 25.424	UTRAN Iur Interface Data Transport & Transport Signalling for Common Transport Channel Data Streams
TS 25.425	UTRAN Iur interface user plane protocols for Common Transport Channel data streams
TS 25.426	UTRAN Iur and Iub interface data transport & transport signalling for DCH data streams
TS 25.427	UTRAN Iub/Iur interface user plane protocol for DCH data streams
TS 25.430	UTRAN Iub Interface: General Aspects and Principles
TS 25.431	UTRAN Iub interface layer 1
TS 25.432	UTRAN Iub Interface: Signalling Transport
TS 25.433	UTRAN Iub interface NBAP signalling
TS 25.434	UTRAN Iub Interface Data Transport and Transport Signalling for Common Transport Channel Data Streams
TS 25.435	UTRAN Iub Interface User Plane Protocols for Common Transport Channel Data Streams
TS 25.442	UTRAN Implementation Specific O&M Transport
TS 29.108	Application of the Radio Access Network Application Part (RANAP) on the E-interface
TR 25.832	Manifestations of Handover and SRNS Relocation
TR 25.853	Delay Budget within the Access Stratum
TR 25.931	UTRAN Functions, Examples on Signalling Procedures
UTRAN RF parameters & performance requirements (RAN4)	
TS 25.101	User Equipment (UE) radio transmission and reception (FDD)
TS 25.102	User Equipment (UE) radio transmission and reception (TDD)
TS 25.104	Base Station (BS) radio transmission and reception (FDD)
TS 25.105	UTRA (BS) TDD: Radio transmission and reception
TS 25.113	Base station and repeater electromagnetic compatibility (EMC)
TS 25.123	Requirements for support of radio resource management (TDD)
TS 25.133	Requirements for support of radio resource management (FDD)
TS 25.141	Base Station (BS) conformance testing (FDD)
TS 25.142	Base Station (BS) conformance testing (TDD)
TR 25.941	Document structure
TR 25.942	RF system scenarios
TS 34.124	Electromagnetic compatibility (EMC) requirements for Mobile terminals and ancillary equipment

While looking into data rates, the first phase of GPRS (Releases '97/'98) was allowing a maximum of 171.2 kbits/s. That was, by using the eight timeslots available and in the best radio-traffic conditions. The radio interface used for UTRAN, a Wideband Code Division Multiple Access (WCDMA), was originally designed to allow for the Release'99 a maximum (theoretical) peak rate of around 2 Mbits/s.

For this, a Direct-Sequence Code Division Multiple Access scheme was chosen. The "Wideband" dimension of the frequency is created by multiplying in time the data sequence with a variety of CDMA spreading codes. The channel coding and multiplexing chain is variable and allows to "fit" the selected rate into the physical pipe, offering the flexibility to select a data rate versus the level of interferences created. In other words, this gives the possibility to achieve a trade-off between network capacity, coverage and data/speech rate. The speech codec chosen for UTRAN is suited to this flexibility and can use different (up to eight) source rates, as mentioned in the chapter on speech codec.

The chip rate is 3.84 Mcps. This reflects to an occupied bandwidth (99% of the total integrated power) which shall be less than 5 MHz. Hence, the "Carrier spacing" is of 5 MHz (compared to the 200kHz of GSM/GPRS).

The larger occupied bandwidth of 5 MHz allows to benefit from the multipath nature of the radio propagation. At 3.84 Mcps, a receiver can separate the multipath components and combine them in a constructive way if the time difference between the two multipaths is at least of 0.26µs (a chip duration), i.e. 78 cm. (For memory, the slot duration was equal to 577µs in GSM). This allows to optimise receivers to make the most of the diversity in the multipath propagation.

Two W-CDMA modes co-exist in UTRAN: the Frequency division duplex (FDD) mode and the Time division duplex (TDD) mode⁵. In the FDD mode, two different frequency bands are used for the uplink and downlink directions. The frequency separation between uplink and downlink, or duplex distance, is of 190 MHz or 80 MHz in regions 1 or 2 (the use of other duplex distances is not precluded). In the TDD mode, the same frequency is used for both the uplink and downlink directions. Intended to operate in an unpaired spectrum, the direction of the transmission is alternated in time in this latest mode which allows to provide asymmetric traffic in uplink and downlink depending on the number of timeslots that are configured for each link.

At higher layers, the definitions of the two modes converge.

The demodulation is coherent, in other words an internal time reference is used. Either the Common Pilot Channel (CPICH) (for FDD) or the Dedicated physical control channel (DPCCCH) can be used (as a result, the Base Station / User Equipment (UE) do not need to be synchronised to a third party system).

The frequency carrier is defined by (the exact spectrum available remains country-specific):

Frequency division duplex (FDD)		Time division duplex (TDD)	
Region 1 (e.g. Europe and Africa)		Region 1 (e.g. Europe and Africa)	
1920-1980 MHz	Uplink	1900 – 1920 MHz	(Uplink and Downlink).
2110-2170 MHz	Downlink	2010 – 2025 MHz	
Region 2 (e.g. America)		Region 2 (e.g. America)	
1850-1910 MHz	Uplink	1850 – 1910 MHz	(Uplink and Downlink).
1930-1990 MHz	Downlink	1930 – 1990 MHz 1910 – 1930 MHz	

While the R'97/R'98 specifications were allowing only a maximum of two simultaneous Packet-Switched connections (one in the uplink and one in the downlink direction), the Radio Resource Management (RRM) of UTRAN offers the possibility to multiplex services with different quality requirements on a single connection, e.g. video, packet data and speech.

Selection of the properties of a radio bearer is possible, with its associated throughput, transfer delay (from real-time to best-effort) and data error rate (from 10% on frame error rate to 10⁻⁶ bit error rate). This is aimed to fulfil different applications, with different Quality of Service (QoS) requirements. Furthermore, bearer reselection is possible when e.g. the system becomes overloaded (on a 10ms basis - frame duration). Bearer reselection is one side of the load controls, in effect a load-based packet scheduling correlated with interferences, given by the nature of the UTRAN interface.

Due to the intrinsic correlation between load and interferences within UTRAN, output powers and their variations are of prime essence for controlling/allowing the load/services within the cells. Hence, UTRAN has defined a power control, both in the uplink and downlink directions (e.g. in FDD it is controlled on a 1500Hz basis; it was of a maximum of 2Hz in GSM). The Network instructs the UE to go up/down in output power. The Base Station uses a target Signal to interference ratio (SIR) to adjust its output power. One of the prime goal of the power control is to compensate the "near-far" effect in the uplink direction: if a UE was not able to adjust rapidly its transmission it could cause for example undesirable noise rise at the base station receiver.

The overall architecture of the radio access network is shown in the red elements of the figure on UMTS and GSM Network Architecture (in section "2. Architecture of the GSM-UMTS Platform").

The architecture of this radio interface consists of a set of radio network subsystems (RNS) connected to the CN through the Iu interface. An RNS consists of a radio network controller (RNC) and one or more entities

⁵ Alternatively, W-CDMA is sometimes used only for the FDD mode. In this case, TDD is said to use the TD-CDMA technology (Time Division – Code Division Multiple Access). In this document, W-CDMA is said to be the technology both for FDD and TDD.

called Node B. Node B is connected to the RNC through the Iub interface. Each Node B can handle one or more cells. The RNC is responsible for the handover decisions that require signalling to the user equipment (UE). The RNCs of the RNS can be interconnected through the Iur interface. Iu and Iur are logical interfaces, i.e. the Iur interface can be conveyed over a direct physical connection between RNCs or via any suitable transport network.

The figure below, entitled Radio Interface Protocol Architecture of the RRC Sublayer, L2 and L1, shows the radio interface protocol architecture for the radio access network. On a general level, the protocol architecture is similar to the ITU-R protocol architecture as described in Rec. ITU-R M.1035. Layer 2 (L2) is split into the following sub-layers; radio link control (RLC), medium access control (MAC), Packet Data Convergence Protocol (PDCP) and Broadcast/Multicast Control (BMC). Layer 3 (L3) and RLC are divided into control (C-plane) and user (U-plane) planes. In the C-plane, L3 is partitioned into sub-layers where the lowest sub-layer, denoted as radio resource control (RRC), interfaces with L2. The higher-layer signalling such as mobility management (MM) and call control (CC) are assumed to belong to the CN. There are no L3 elements in this radio interface for the U-plane.

Each block in this figure represents an instance of the respective protocol. Service access points (SAPs) for peer-to-peer communication are marked with circles at the interface between sub-layers. The SAP between MAC and the physical layer provides the transport channels. A transport channel is characterized by how the information is transferred over the radio interface.

The general classification of transport channels is into two groups:

- Common transport channels where there is a need for explicit UE identification when a particular UE is addressed or a particular group of UEs are addressed.
- Dedicated transport channels where a UE is implicitly identified by the physical channel, i.e. code and frequency.

The SAPs between RLC and the MAC sub-layer provide the logical channels. A logical channel is characterized by the type of information that is transferred over the radio interface. The logical channels are divided into control channels and traffic channels.

In the C-plane, the interface between RRC and higher L3 sub-layers (CC, MM) is defined by the general control (GC), notification (Nt) and dedicated control (DC) SAPs. These SAPs are not further discussed in this overview.

Also shown in the figure below are connections between RRC and MAC as well as RRC and L1 providing local inter-layer control services (including measurement results). An equivalent control interface exists between RRC and the RLC sub-layer. These interfaces allow the RRC to control the configuration of the lower layers. For this purpose separate control SAPs are defined between RRC and each lower layer (RLC, MAC, and L1).

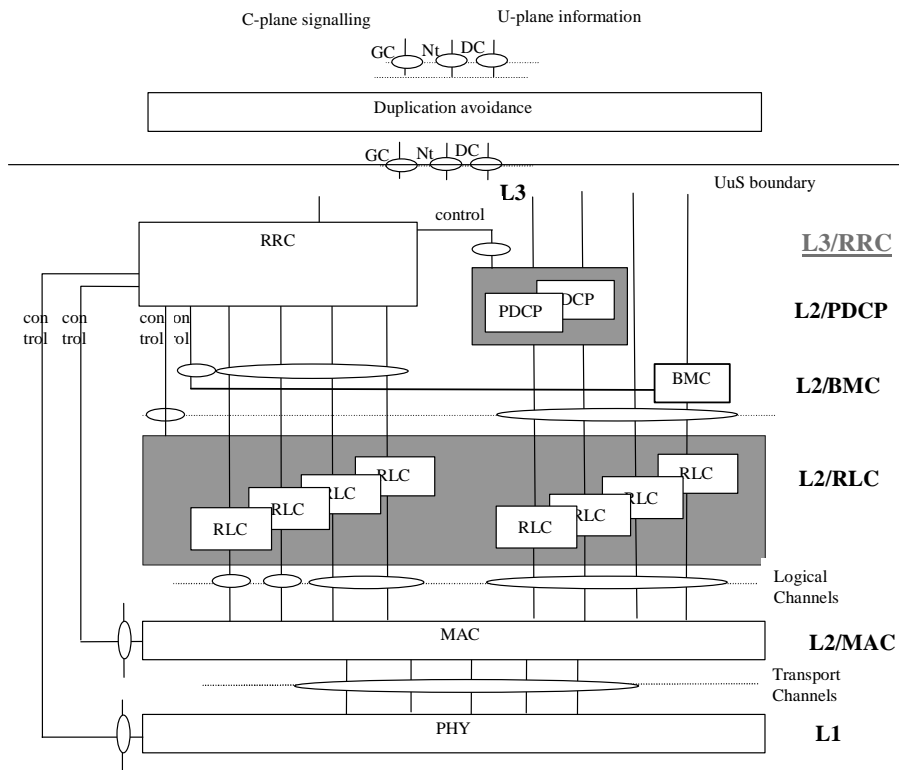

Radio Interface Protocol Architecture of the RRC Sublayer, L2 and L1

Within the Release 99 standards, a number of schemes are also available in order to improve the system (or simply allow it to work fully):

Transmission diversity:

That is mainly in order to improve the reception quality of the downlink direction (exploit diversity gain to reduce power consumption for radio links in the cell i.e. increase the downlink capacity). Two antennas are used at the Base Station, the UE combines the received signals. This is a form of spatial/antenna diversity (performance requirements on the final recombination are defined for the UE).

Soft handover used in the FDD mode:

In effect, the soft handover scheme is a form of macro diversity. Two sectors from two different base stations communicate simultaneously with the UE (i.e. two radio interface links are used, using two power control loops). Both signals are received and used by the UE. In the uplink direction, the Radio network controller (RNC) within the network selects the best frame, at each interleaving period (every 10-80 ms).

Softer handover used in the FDD mode:

In this case, the two sectors belong to the same base station. The two signals (using the same power control loop) can be combined within the receivers of the UE and the base station. Two separate codes are used in the downlink direction, so that the UE can separate the signals. The difference is that in the uplink direction, combining is performed within the same base station. This combining can be performed in the baseband received of the base station, by opposition to the more drastic selection in the RNC performed by the soft handover.

Compressed mode used in the FDD mode:

When parallel measurements to another UTRAN frequency or a GSM frequency is meant to be performed (for e.g. UE reporting, in order to allow handovers), a pure parallel measuring would require a dual receiver. A way to ease the parallel frequency measuring has been introduced, namely the compressed mode, which in essence is a slotted mode leaving some time for the UE to perform measurement on another frequency. The compressed mode is available in the uplink and downlink directions. Several transmission time reduction techniques are available to allow this creation of gaps: "spreading factor reduction by 2", "higher

layer scheduling" or "puncturing". The goal is to create "holes" in time, so that this can be used for measuring other frequencies. When this scheme is used, receiver and transmitter need to be clearly synchronised in time, so that they know exactly when the "holes" become available. That is why compressed mode patterns are clearly defined. Those compressed mode patterns define e.g. Transmission Gap Lengths (TGL).

Handovers between the two different modes, FDD and TDD, are possible.

As hinted by the previous paragraphs, handover to/from GSM radio access networks are also possible. The aim was to have the same requirements available than in the intra-GSM case. All handovers (in dedicated mode), network controlled cell-reselection from GPRS also applies to UTRAN as a target system. The user can expect a continuity of service⁶ between the two different systems (with the GSM limitations on e.g. the number of simultaneous connections). Dedicated messages have been introduced for the network to request handovers/cell-reselections between the different systems. Thresholds indicating values to take into account for autonomous UE inter-system cell-reselections have also been introduced (with the possibility to use different thresholds within each source system, to avoid ping-ping effects).

A scheme allowing a quicker implementation and fulfilling e.g. agreements between operators of different systems (GSM and UTRAN) was also introduced for the Release'99: the "equivalent PLMN" scheme. This allows an autonomous cell-reselection in (packet) idle modes for the UE, between different systems. In effect, a set of PLMN Identities are indicated by the networks, instead of one PLMN Identity. The UE can reselect between the systems, using the thresholds required for the decision, in effect as if it was roaming within the same PLMN.

4 Mandatory Speech Codec for Narrowband Telephony Service

Acronym: AMR-NB or AMR

References for WI " Mandatory Speech Codec for Narrowband Telephony Service "

Document	Title/Contents
SA4_Work_Items_History	WI Sheet
SP-99060	WID WI S4-1: Mandatory Speech Codec for Narrow band Speech Telephony Service
Impacted Specifications	
04.08	Mobile radio interface layer 3 specification
05.01	Physical layer on the radio path; General description
05.02	Multiplexing and multiple access on the radio path
05.03	Channel Coding
05.05	Radio transmission and reception
05.08	Radio subsystem link control
05.09	Link Adaptation
05.50	Background for Radio Frequency (RF) requirements
08.60	Inband control of remote transcoders and rate adaptors for Enhanced Full Rate (EFR) and full rate traffic channels
08.61	In-band control of remote transcoders and rate adaptors for half rate traffic channels
11.21	BSS Radio aspects
New Dedicated Specifications	
TS 05.09	Radio Access Network; Link Adaptation

⁶ This was once mentioned as a stand-alone item called "GSM/UMTS service continuity and equivalent PLMN".

TS 26.071	Mandatory Speech Codec speech processing functions AMR Speech Codec; General Description
TS 26.073	ANSI-C code for the Adaptive Multi Rate speech codec
TS 26.074	AMR speech codec test sequences
TS 26.090	AMR speech codec; Transcoding functions
TS 26.091	AMR speech codec; Error concealment of lost frames
TS 26.092	AMR Speech Codec; Comfort noise aspects
TS 26.093	AMR Speech Codec; Source Controlled Rate operation
TS 26.094	AMR speech codec; Voice Activity Detector (VAD)
TS 26.101	AMR Speech Codec Frame Structure
TS 26.102	AMR speech codec; Interface to lu and Uu
TS 26.103	Speech Codec List for GSM and UMTS
TS 26.104	ANSI-C code for the floating-point Adaptive Multi Rate (AMR) speech codec
TR 26.975	Performance characterization of the Adaptive Multi-Rate (AMR) speech codec

This scope of this feature, also known as “Mandatory Speech Codec for Narrowband Telephony Service”, is to define the default speech codec for UMTS (both for FDD and TDD). This definition was in fact limited to a selection of one among several existing codecs: the proposed codecs were GSM AMR, IS127 EVRC, ITU G.729 and MPEG-4 speech codec.

A comprehensive set of subjective tests was developed to compare the performance of the proposed candidates in different conditions: with and without background noise, with channel errors (using Error Patterns specifically developed by ARIB for this project), in tandeming⁷ and with music on hold. A number of organisations performed the required subjective tests with the proposed candidate speech codecs. The codec selection was completed by April 99 and the codec characterisation was completed at a later date, mainly in TR 26.975 but also left until Release 6 for the PS domain.

As a result of the selection, TSG-SA adopted the GSM AMR (narrowband) speech codec as the mandatory default 3G speech codec, for the following reasons:

- The GSM AMR includes multiple (8) codec modes providing the required flexibility to offer a toll quality speech service without compromising the system capacity;
- It includes the GSM EFR (at 12.2 kbps) and the IS136 EFR (at 7.4 kbps) offering a high level of compatibility with key 2G systems;
- No other candidate codec provides better performances than the GSM EFR (highest mode of GSM AMR). The GSM EFR was found to provide the best performance with respect to the requirements set by ARIB for the Mandatory Speech codec, often exceeding the required performance level;
- At equivalent source rate, the internal codec modes of AMR always provide equivalent or better performance than the other candidate speech codecs. For example the AMR codec modes at 7.95 kbit/s (and 7.4 kbit/s) were found equivalent or better than the IS127 EVRC (8.55 kbit/s mode) or the G.729 (8 kbit/s);
- The AMR speech codec specifications were already approved by ETSI SMG. The corresponding C-Code was released as part of the specifications. The completion of the 3GPP mandatory speech codec specifications in the time frame presented above would not be achievable if the selected codec specifications and C-Code was not already publicly available.
- It is equivalent to wireline speech codec (ADPCM - G.726) in No Errors conditions
- The degradation is limited under normal operational conditions (with channel errors, in tandeming)
- It offers a good trade off complexity/performances for low cost implementation in 3G systems.

⁷ “tandeming” is the use of two codecs in the transmission path, e.g. in GSM, the voice is AMR-encoded in the source terminal, then AMR-decoded in the source BTS, then transcoded to be transported in the core network, and is again AMR-encoded in the destination BTS and finally decoded in the destination terminal.

After the selection of the speech codec, the complete operation of the codec was defined on top of FDD and TDD channels, including the discontinuous transmission operation and/or variable rate operation. The definition of the best channel coding (based on existing bearers versus dedicated bearer with unequal protection) was defined in relation with the WGs RAN1 and RAN2.

Finally, the operation of the mandatory speech codec was fully characterized in multiple 3G operational environment, except for PS domain (left to Rel-6).

4.1 AMR - NS (Noise Suppression)

Acronym: AMR-NS

References for WI " AMR - NS"	
Document	Title/Contents
SA4_Work_Items_History	WI Sheet
Impacted Specifications	
New Dedicated Specifications	
TS 06.77	Minimum Performance Requirements for Noise Suppressor Application to the AMR Speech Encoder
TR 06.78	Results of the AMR Noise Suppression Selection Phase

After an extensive selection phase (described in TR 06.78 "Results of the AMR Noise Suppression Selection Phase") no candidate algorithm fulfilled ALL quality requirements set for this exercise, hence no standard Noise Suppressor Application to the AMR Speech Encoder was selected.

Nevertheless, TS 06.77 "Minimum Performance Requirements for Noise Suppressor Application to the AMR Speech Encoder" was approved, and can be utilised by those Companies willing to prove evidence that their product fulfils a "minimum set of requirements". Results from subjective and/or objective tests conducted by professional labs on behalf of a proponent Company can be provided to WG SA4 for endorsement of a proprietary AMR-NS algorithm. The endorsement means that, based on the test results presented to SA4, SA4 acknowledge the proposed proprietary algorithm meets the recommended minimum performance requirements as set in 3GPP TS 06.77. A statement of this acknowledgement is then included in the TSG SA meeting report. No AMR-NS algorithm itself is specified nor standardised in 3GPP, i.e. it must be stressed that the "endorsement" does not have such meaning. See TS 06.77 for details.

5 Codec for Low Bitrate Multimedia Telephony Service (H.324 M)

Acronym: H234M

References for WI " Codec for Low bit rate Multimedia Telephony Service "	
Document	Title/Contents
SA4_Work_Items_History	WI Sheet
SP-99060	WID WI S4-2: Codec for Low bit rate Multimedia Telephony Service
Impacted Specifications	
TS 26.110	Codec for Circuit Switched Multimedia Telephony Service; General Description
TS 26.111	Codec for circuit switched multimedia telephony service; Modifications to H.324
TR 26.911	Codec(s) for circuit switched multimedia telephony service; Terminal implementor's guide
TR 26.912	QoS for Speech and Multimedia Codec; Quantitative performance evaluation of H.324 Annex C over 3G
TR 26.915	Echo Control For Speech and Multi-Media Services
New Dedicated Specifications	
	none

The scope of the feature is to specify the default codec for multimedia telephony service for UMTS. In this release, multimedia telephony service is limited to low bitrate, circuit switched connections.

The specification of a default multimedia telephony codec enables terminals capable of low-cost, high-quality, real-time, two-way multimedia communications. It also allows interoperability of different manufacturers' equipment, thus broadening the potential market for such devices.

Here again, the specification was in fact just a selection. The results on the tests were included in the Technical Report 26.912 on the Quantitative Evaluation of Circuit Switched H.324 Based Multimedia codecs over 3G.

ITU-T H.324/ANNEX C (Multimedia Telephone Terminals Over Error Prone Channels) was chosen as the core of the protocol. Indeed, it makes an efficient use of the radio resources and takes into account the error prone nature of radio based networks. Where H.324/ANNEX C falls short, other relevant standards are used as follows:

- AMR speech codec is adopted as the only mandatory speech codec for CS Multimedia Telephony services to offer the same level of speech quality as the basic speech service. Note that the ITU H.324 mandates the support of the G.723.1 speech codec, which is considered by the experts as providing a lower quality level than the higher modes of AMR.
- H.263 was adopted as the only mandatory video codec. Note that H.324 also mandates terminals to support the less advanced H.321 video codec.
- H.223 Annex B (which includes Annex A) is specified as the minimum Multiplex Error Detection and Protection level. This level was considered to provide an acceptable performance/complexity trade-off.
- Additionally, call setup and termination are not defined in H.324/ANNEX C. 3GPP described it in TS 24.008 (and not in TS 26.112, withdrawn before its completion and replaced by 24.008).

The mandatory characteristics described above are far from removing any option in H.324. TSG-S4 believed that it was essential to complete this set of mandatory requirements with a number of "recommendations" to help in the implementation of 3G Terminals in order to guarantee enough error resilience and favor efficient terminal interworking. Some of the key "recommendations" are:

- To support the optional G.723.1 speech codec
- To support the optional MPEG-4 video codec

H.323 could also be used to satisfy the above requirements for packet switched connections. However, there are additional issues, relative to H.324 (such as IP over wireless network), that need to be addressed within 3GPP that would preclude consideration of H.323; however, this Work Item addressed also those H.323 issues.

The interoperability with other or existing systems was a low priority because of the low penetration of fixed access Multimedia Terminals and services. A consequence of this choice is that transcoding or gateway functions will be required when interoperability with existing Multimedia Terminals not supporting H.324 Annex C must be provided.

The related codec requirements were specified assuming that the 3G systems will carry the Multimedia data flow as one single data flow at the output of the H.223 Multiplex and not separate the different media flows before the H.223 Multiplex to send them over separate radio access bearers. This decision was essentially guided by time constraints for the completion of the corresponding specification and the well established performance of H.324 in this configuration.

6 3G audio-visual terminal characteristics

Acronym: 3G-AVT

References for WI " 3G audio-visual terminal characteristics "	
Document	Title/Contents
SA4_Work_Items_History SP-99129	WI Sheet WID TSG-S4 Work Item on 3G Audio-Visual Terminal Characteristics
Impacted Specifications	
TS 26.131	Terminal acoustic characteristics for telephony; Requirements
TS 26.132	Narrow band (3,1 kHz) speech and video telephony terminal acoustic test specification
New Dedicated Specifications	
	none

The scope of the feature “3G audio-visual terminal characteristics” is to specify the acoustic performance of terminals.

The provision of speech, multimedia (e.g. Video Telephony) and wideband audio services in 3G terminals requires the specification of certain terminal characteristics, notably acoustic and visual (display/camera) characteristics. This feature develops the acoustic and visual requirements and the test methods needed to support these requirements for 3G speech and multi-media terminals in support of the Mandatory speech service, the H.324 and H.323 narrowband video telephony service and wideband speech service work items. The set of requirements and test specifications were passed to 3GPP_TSG_T for inclusion in their terminal specification work.

These specifications detail the requirements for acoustic parameters, such as SLR (Sending Loudness Rating), and the test methods to assess terminal conformance and performance.

7 Quality of Service (QoS)

Acronym: QoS

References for WI " QoS"	
Document	Title/Contents
WIDs	
Impacted Specifications	
New Dedicated Specifications	
TS 23.107	Quality of Service (QoS) concept and architecture

This feature introduces a complete set of terms related to the transport of user information: the different types of “bearers” used in UMTS are defined here. It also specifies the Quality of Service (QoS) attributes for some of the bearer types, in particular for the "GPRS Bearer Service" (also called “UMTS Bearer”). In this sense, this feature is not strictly speaking a service offered to the end user nor to the network operator but is a framework to organise the work related to Quality of Service. A guaranteed end-to-end Quality of Service in the PS domain will not be provided before Release 5.

The terms introduced by this feature are shown in the following figure. Further definition can be found in TS 23.107.

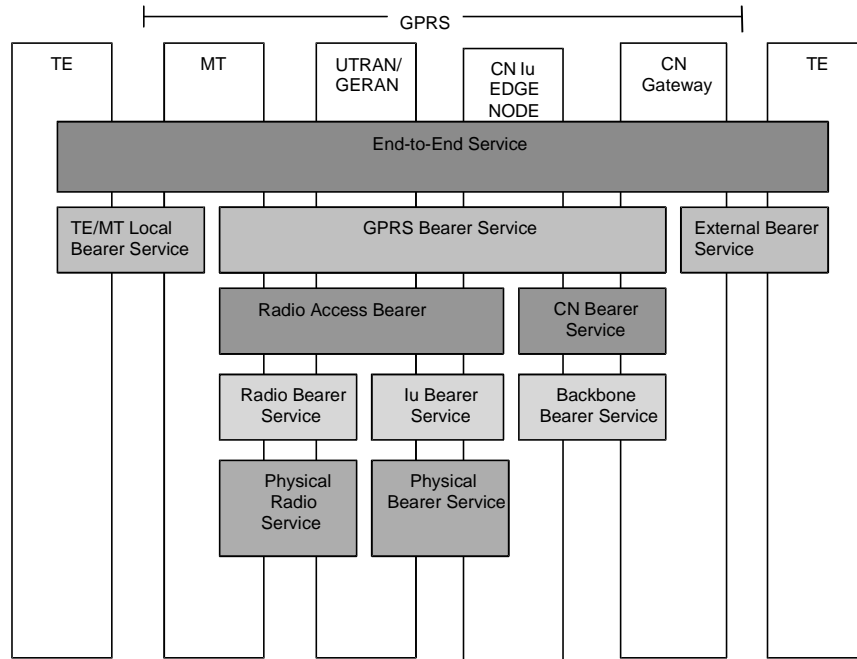

Terminology introduced by the “QoS” Feature

Four different classes of QoS are defined:

- Conversational class: a bearer of this QoS class guarantees the time variation between the incoming and the outgoing packets transported by the bearer, and offers stringent and low delay. It is typically used for conversational services (hence the name...), like (multimedia) telephony.
- Streaming class: the time variation is still guaranteed, but the delay is not as low as in the conversational class, and is typically used for streaming video.
- Interactive class: the request and response are guaranteed within a certain period, while the payload content is preserved. It is to be used e.g. for Web browsing.
- Background class, to be used when the destination is not expecting the data within a certain time, but where the payload content has to be preserved. It has to be used e.g. for background download of e-mails.

For each class, a given set of attributes applies. This set is chosen among a full list of attributes defined for each type of bearers, e.g. the attributes are different for the “GPRS/UMTS Bearer” and for the “Iu Bearer”. The attributes applicable to the “GPRS/UMTS Bearer” and to the “Radio Access Bearer”, defined extensively in this Release, are e.g.: the Maximum and Guaranteed bit rates, the Delivery order, the Residual BER, the Transfer delay, the Traffic handling priority, the Allocation/Retention priority, etc.

The mapping between attributes of different bearer types is partly defined in the standard, e.g. the mapping from GPRS/UMTS Bearer attributes to Radio Access Bearer attributes is defined whereas the mapping from end-to-end (Application) attributes to GPRS/UMTS Bearer attributes is not defined in this Release (only in Release 5). Also the mapping from GPRS/UMTS Bearer attributes to CN Bearer attributes is an operator's choice.

Part 2 – UMTS and GSM Features

8 Location Services (LCS)

Location Services is a Feature providing the ability to localise a phone, called MS (Mobile Station) in GSM and UE (User Equipment) in UMTS. This location information is used to provide services to the end-user (e.g. provide a local map with indication of closest restaurants, etc), for emergency services or for “internal clients”, i.e. a UMTS network entity, like an RNC to direct the beam when space diversity is used (not used at least up to Release 6).

LCS was introduced in GSM Release 98, and was enhanced for GSM Release 99. In this same Release, LCS was also adapted to UMTS.

The location relies on three key functions: the measurement of the radio signals, operated by the LMU (Location Measurement Unit), the calculation of the position and the global coordination, operated by the SMLC (Serving Mobile Location Center), and the dialogue between the network and the external LCS client, operated by the GMLC (Gateway MLC). The architectures, both for GSM and for UMTS, are shown below, extracted from 03.71 for the GSM (GERAN) aspects and from 23.171 for the UMTS (UTRAN) aspects.

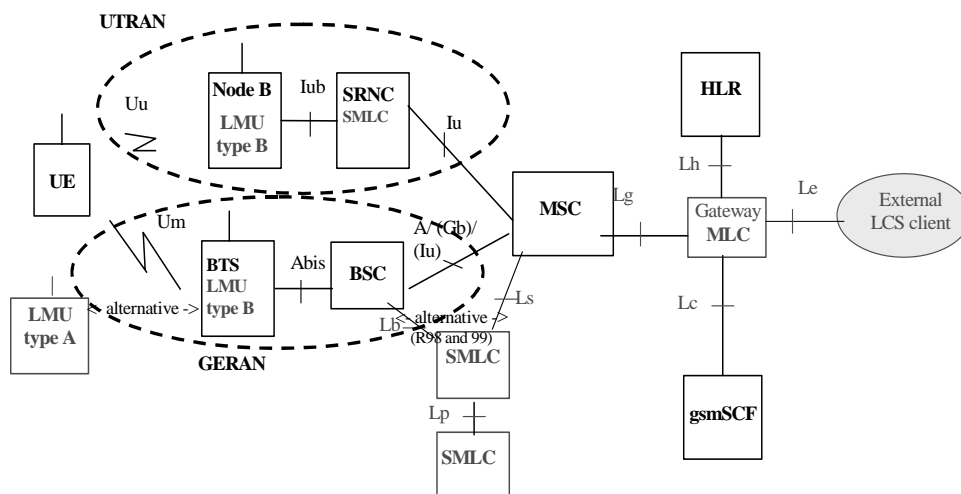

UMTS and GSM LCS Architecture

The entity being tracked is the MS/UE at the far left (shown as “UE” in the figure). The External LCS client at the far right is the entity using the location indication to provide the service to the User.

The “alternatives” mean that two options are possible:

- the LMU can be on the infrastructure side or can be a stand-alone entity, communicating with the infrastructure re-using the Radio interface (in this case, it has its own IMSI),
- the SMLC can be connected to the BSC or to the MSC.

Both options reflect lacks of decision at 3GPP in front of balanced advantages: in the first case, a type A LMU (stand-alone entity) is easier to deploy but consumes radio resources, contrarily to a type B LMU. With respect to the second option, connecting an SMLC connected to the MSC reduces the number of connections (there are less MSC than BSCs) but involves the MSC for relaying a user-access centric dialogue between the BSC and the SMLC (this options disappears in later releases).

The flows for the External Client to get the position of the User are the following:

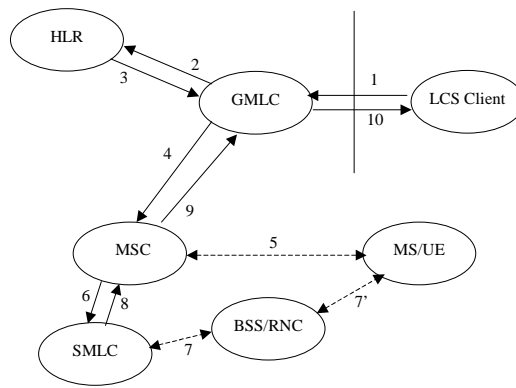

Flows for LCS

1. The LCS client requests to his allocated GMLC the location of the UE by sending the message « LCS Service Request » on the Le interface (fully defined only from Release 5 onwards: the dialogue is on a proprietary basis for previous releases).
2. The GMLC contacts the HLR to obtain the address of the current VLR/MSC of the subscriber.
3. The HLR answers, after having checked that the requesting GMLC is authorised to obtain the location of the subscriber (2 and 3: MAP messages *Send_Routing_Info_For_LS*, 09.02, 1A.1.2).
4. The GMLC then contacts the MSC/VLR in the visited network to obtain the location information. The VLR checks that the subscriber authorises the transmission of his location. (4 and 9: MAP messages *Provide_Subscriber_Location*, 09.02, 1A.2.2)
5. Once these checks have been made, the terminal is, if necessary, paged and authenticated, and encryption is potentially activated. The MS is then supposed to be reachable if LCS client asks for it (*Location_Notification_Invoke* and *Location_Notification_Return_Result* messages, presented in stage 2 but not defined in stage 3).
6. The MSC then starts the active phase of recovery of the location of the MS, soliciting the SMLC with BSSMAP LE Perform Location request (09.31) message. This message is sent directly from the MSC to the SMLC in the event of "NSS-based solution" or forwarded transparently by the BSC for the "BSS-based solution".
7. The radio location procedure is then triggered: several procedures are defined, which can imply or not the MS/UE. As a result of the radio location procedure, the SMLC knows the position of the MS.
8. The MS/UE position is then forwarded from the SMLC towards the LCS client. The payload of this message is the Information Element "Location Estimate" or "Geographic Location IE" (different names are used in different documents), which coding is given in 03.02.
9. The location information then reaches the requesting GMLC (in response to message 4: *Provide_Subscriber_Location*, 09.02, 1a.2.2).
10. Lastly, this information reaches its final recipient, the LCS client, by the message "LCS Service Response", which, as its homologue "LCS Request service" is mentioned in stage 2 but not in stage 3 for this Release.

The radio location procedure (step 7 in the above procedure) can be of four types in GSM and three types in UTRAN. The GSM procedures are:

- Timing Advance (TA). This method provides a location area of the shape of a ring centered on the BTS whose identity is returned by the TA Response message. The ray of the ring is the Timing Advance multiplied by the speed of the light.
- Uplink Time Of Arrival (TOA). It consists in determining times of arrival at three LMUs (with known geographical co-ordinates) of a signal emitted by the mobile. These times determine the distance from the mobile compared to each one of these point from where, by triangulation, the position of the mobile is deduced.
- Enhanced Observed Time Difference (E-OTD). The MS measures the moments of arrival of a burst sent by three visible BTSs. Two options are possible: calculation is performed either directly by the MS (MS Based E-OTD), or in the SMLC with the measurements provided by the MS (MS Assisted E-OTD).

- Assisted GPS: the coordinates of the MS are directly obtained by the GPS system (Global Positioning System), outside the GSM network.

The UMTS procedures are:

- Cell ID based. This is the simplest case, where the resulting location information is simply the serving cell identity (Node B) or a geographical area corresponding to this cell (a disk centred on the BTS/Node B), plus possibly some other indications like the RTT (Round Trip Time).
- OTDOA-IPDL (Observed Time Difference Of Arrival – Idle Period DownLink), where the MS measures the difference of time of arrival of a reference signal at two Node B, which makes it possible to locate the MS on a hyperbole based on these two Node Bs. The use of a third node B makes it possible to identify two other hyperboles and the intersection of these hyperboles locates the MS. One can thus speak about a solution inherited of the hyperbolic solution E-OTD.
- Network Assisted GPS, derived from the homonymous method in GSM.

A certain number of UMTS other methods were quoted during long in stage 2, but were finally removed, such as: AOA (Angle Of Arrival), OTOA (Observed Time Of Arrival), OTDOA-RNBP (OTDOA Reference Node-Based Positioning) and OTDOA-PE (OTDOA Positioning Elements).

In GSM, E-OTD and A-GPS request an active behaviour of the MS/UE, as well as OTDOA-IPDL and A-GPS in UMTS. These methods are more accurate than the other ones, but they need to have LCS-capable MS/UE, i.e. they will not work without changing the MS/UE.

All these options on architecture and on radio methods did not facilitate a fast and low cost introduction of LCS standard in the market, as one can see several years after the LCS feature was standardised.

Finally, not less than 5 new protocols are introduced for GSM LCS:

- RRLP (Radio Resource LCS Protocol), defined in 04.31, for the dialogue SMLC to target MS
- LLP (LMU LCS Protocol), defined in 04.71, for SMLC to LMU dialogues
- BSSLAP (BSS LCS Application Leaves), defined in 08.71, for SMLC to BSC dialogues
- SMLCPP (SMLC Peer Protocol), defined in 08.31, for SMLC to SMLC dialogues
- BSSAP LE defined in 09.31, for the needed DTAP and BSSMAP extensions to support LCS,

In UTRAN, the Stage 2 is defined in a dedicated specification: TS 25.305 entitled "Functional stage 2 specification of Location services in UTRAN". The Stage 3 is much more integrated into the existing protocols than in GSM. It is defined through "General" UTRAN Stage 3, namely mainly in 25.331 ("Radio Resource Control (RRC); protocol specification"), but also in the following specifications:

- TS 25.306: "UE Radio Access Capabilities".
- TS 25.413: " UTRAN Iu interfaces RANAP signalling".
- TS 25.423: " UTRAN Iur interfaces RNSAP signalling".

9 CAMEL phase 3

References for WI "CAMEL Phase 3"

Impacted Specifications	
TS 22.078	CAMEL - Stage 1
TS 23.078	CAMEL – Stage 2
TS 29.078	CAMEL – Stage 3

CAMEL feature (Customized Applications for Mobile network Enhanced Logic) is a network feature that provides the mechanisms to support services of operators which are not covered by standardised services even when roaming outside the HPLMN.

The third phase of CAMEL enhances the capabilities of phase 2. The following capabilities are added:

- Support of facilities to avoid overload: The purpose of this functionality is to control SCP (Service Control Point) overload situations within the HPLMN. It is possible for the CSE to suppress either all or some CAMEL interrogations from a V/IPLMN, when the V/IPLMN is the subscriber's HPLMN. If there is a bilateral agreement the operators may also apply congestion control between different networks. If congestion control prevents contact with the CSE, the V/IPLMN shall proceed in accordance with the Default Call Handling.

Congestion Control is applicable to CAMEL control of circuit switched call. It is not applicable to CAMEL control of GPRS session and PDP context, and to CAMEL control of short message.

- Capabilities to support Dialed Services: The purpose of these capabilities is to support HPLMN specific service numbers (Subscribed dialed services (D-CSI)) and VPLMN specific service numbers (Serving Network Dialed services (N-CSI))
- Capabilities to handle mobility events, such as (Not-)reachability and roaming: The SCP may whenever request HLR to provide subscriber status and/or location information.
- Control of GPRS sessions and PDP contexts: This functionality enables interworking with GPRS and is useful for GPRS- pre paid interworking (not content based).
- Control of mobile originating SMS through both circuit switched and packet switched serving network entities (not content based): This functionality enhances pre paid service and VPN. There is no control of MT SMS in CAMEL phase 3.
- Interworking with SoLSA (Support of Localised Service Area). Support for this interworking is optional;
- The CSE can be informed about the invocation of the GSM supplementary service CCBS: It is possible to mark for a subscriber that a notification shall be sent to the CSE when CCBS supplementary service is invoked (in addition to notification of supplementary services available in CAMEL phase 2).

10 Multimedia Messaging Service (MMS)

Acronym (if any): MMS

References for WI " Multimedia Messaging Service (MMS)"

Document	Title/Contents
TP-000022	WI Sheet
Impacted Specifications	
New Dedicated Specifications	
22.140	MMS stage 1
23.140	MMS stage 2/3

After SMS and EMS, the next stage of messaging evolution is MMS, which delivers an even richer messaging experience. Rel99 was the first Release which included MMS. MMS allows users to send and receive messages exploiting a large array of the media types available today e.g. text of almost unlimited length, images, audio and video clips, while also making it possible to support new content types as they become popular. MMS supports standard image formats such as GIF (Graphics Interchange Format) and JPEG (Joint Picture Expert Group), video formats such as MPEG 4 (Motion Picture Expert Group) and audio formats and MIDI (Musical Instrument Digital Interface). Multiple media elements can be combined into a composite single message. Messages can be sent either to a mobile phone or to an e-mail address, which offers the customer a wide range of users to communicate with.

11 Multiple Subscriber Profile (MSP) based on CAMEL ph. 3

References

Document	Title/Contents
WI	Roll-over WI from R98 (02.97)
TS 22.097	Advanced Addressing

Multiple Subscriber Profile is an optional service to enable mobile subscribers to have several profiles associated with a single IMSI, with each profile being a subscription option. Each profile may be used for mobile originated and mobile terminated calls.

Up to four different profiles can be provisioned against a subscriber using the MSP feature. This will allow the subscriber to separate her telecommunication service needs into different identities (e.g. business and home).

The charges accrued for services shall be associated with the appropriate profile, allowing separate charging for each profile.

A supporting visited network shall indicate (on the billing record) for charging purposes the profile used.

For R99, MSP Phase 2 was added in the form of a CR (002) and the interaction with Multicall was adapted.

12 Short Message Service (SMS) enhancements

Acronym (if any): SMS

References for WI " Short Message Service (SMS)"	
Document	Title/Contents
TP-000022	WI Sheet
Impacted Specifications	
TS 23.038	Alphabet and language specific information
TR 23.039	Interface protocols for the connection of SMSCs to SMEs
TS 23.040	Technical realization of SMS Point-to-Point
TS 23.042	Compression algorithm for text messaging services

This work items includes SMS for 3GPP terminals which is fully compatible with the GSM SMS service. Additional enhancements and improvements have been introduced e.g. Enhanced Messaging Service (EMS) allowing small pictures, sounds, animations to be transferred via SMS.

EMS (Enhanced Messaging Service) Rel-99 includes:

- Text formatting: Alignment, Font size, Style
- Basic pictures: small (16*16 pixels), large (32*32 pixels) or pictures of variable size, plain black and white
- Animations: Predefined, User Defined, 8*8 pixels and 16*16 pixels
- Sound: 10 different sounds Predefined, User Defined according to the iMelody format

13 Mobile Station Execution Environment (MExE)

Acronym (if any): MExE

References for WI " Mobile Station Execution Environment (MExE)"	
Document	Title/Contents
WI	Roll-over WI from R98 (02.57)
TP-000022	WI Sheet
Impacted Specifications	
TS 22.057	Mobile Station Application Execution Environment (MExE); Service requirements, Stage 1
TS 23.057	Mobile Station Application Execution Environment (MExE); Functional description; Stage 2
TS 22.057	Mobile Execution Environment (MExE) service description; Stage 1
TS 22.101	Service aspects; Service principles

MExE is a feature introduced in GSM Release 98, enhanced in GSM Release 99 to cover the following additional enhancements: SIM MExE certificate management, security clarifications and QoS aspects. This work item includes MExE for 3GPP terminals which is fully compatible with GSM MExE Release 99, providing a flexible API for the terminal for third party applications.

MExE provides a standardised execution environment in an MS, and an ability to negotiate its supported capabilities with a MExE service provider, allowing applications to be developed independently of any MS platform. The MS can then be targeted at a range of implementations for MExE from small devices with low bandwidth, limited displays, low processor speeds, limited memory, MMI etc., to sophisticated with a complete MExE execution environment.

A standardised means of negotiating the MSs' and network's capabilities is supported. This negotiation permits the mutual exchange of capabilities between the MS and the MExE server, and possibly includes the service profile of the user and capabilities of the network.

A network can be a transport bearer for the negotiation, interaction and transferring of applications, applets and content with the MS, however it need not necessarily be the provider of the MExE services with which the MS's execution environment is interacting with. The network may also be the intermediary between two MSs which are engaged in a MExE service with each other, with the network effectively supplying the "pipe" and not playing a MExE role in the connection.

Network nodes, nodes external to the network, or even MSs are the entities which can interact with the MS's execution environment.

[MExE Security in SP-000303 (T2 MCC still has to check this)]

14 Multicall

Acronym: Multicall

References for WI "Multicall"

Document	Title/Contents
NP-99549	Multicall as R99 Work Item
NP-000084	Release 1999 Submission form
NP-000348	Merged WG Status Report For WI R99 Multicall
Impacted Specifications	
TS 24.008	Mobile radio interface layer 3 specification; Core Network Protocols; Stage 3
TS 23.009	Handover procedures
TS 23.108	Mobile radio interface layer 3 specification, Core Network Protocols - Stage 2
TS 24.080	Mobile radio interface layer 3 supplementary services specification; Formats and coding
New Dedicated Specifications	
TS 22.135	Multicall; Service description; Stage 1
TS 23.135	Multicall supplementary service; Stage 2
TS 24.135	Multicall Supplementary Service - Stage 3

Multicall is to allow several simultaneous CS calls with dedicated bearers of independent traffic and performance characteristics, e.g. to allow several CS data bearers to be binded at application level resulting in higher than 64kbits/s data rates. Or this feature can allow simultaneous speech and data calls. The Multicall was defined as a supplementary service in Release 99 with limitation of only one CS bearer to be used for speech at any one times. A speech call is one of TS11 (Telephony), TS12 (Emergency Calls), and TS61 (Alternate speech/fax). If the bearer capability information is not available, e.g. the call is originated/transited by a PSTN, the basic service cannot be deduced and the network shall, for Multicall purposes, handle the call as telephony. A held call shall be regarded as using the bearer which was used while the call was active. With Multicall it is possible to release each active CS call independently of any other CS call. When the Multicall supplementary service is provisioned the maximum number of simultaneous CS bearers available to the subscriber (Nbr_SB) shall be defined as part of the subscription. The value for Nbr_SB shall in the range from 2 up to 7.

All of the radio signalling specific to Multicall is at the served mobile subscriber side. The radio signalling on the other side uses basic call signalling procedures only.

The mobile subscriber supporting Multicall shall include the stream identifier (SI) information element. The purpose of the stream identifier (SI) information element is to associate a particular call with a Radio Access

Bearer (RAB), and to identify whether a new traffic channel is requested for the call. 3GPP TS 24.008 defines the rules on allocating stream identifiers. MS capability (number of bearers and number of speech bearers) is included in Call Control IE (CR to 24.008, N1-000490). And since the MS shall be aware of NW capabilities, the NW indicates its Multicall capability to the MS by using CC message (CR to 24.008, N1-000560). When the MS is located in a NW not supporting Multicall, it shall not request multiple bearers (CR 24.008, N1-000489). The subject of inter-MS handover issues was solved in CR N1-000638. The concern was that MSC-A needs to know which one RAB has been selected in MSC-B in the subsequent handover from UMTS to GSM to release some calls not to be handed over after handover completion.

15 Open Service Architecture (OSA)

Acronym: OSA

References for WI "OSA"	
Document	Title/Contents
WIDs	
None	Historical information can be found in the meeting reports of SA#5, 6, 7, 8 as well as in the following documents SP-99416 (SA#5), SP-000095 and SP-000155 (SA#7),
Impacted Specifications	
None	None
New Dedicated Specifications	
TS 22.121	Service aspects; The Virtual Home Environment; Stage 1
TS 23.127	Virtual Home Environment (VHE) / Open Service Access (OSA); Stage 2
TS 29.198	Open Service Architecture (OSI) Application Programming Interface (API) - Part 1
TS 29.998	Open Services Architecture API part 2

These specifications were produced jointly by Parlay, ETSI SPAN (now TISPAN) and 3GPP WGs SA1 (Stage 1), SA2 (Stage 2) and CN5 (Stage 3), so that there is a single set of standard OSA APIs for the whole development community.

Open Service Architecture (now Access) - OSA - allows service development by operators and third parties. OSA enables service application developers to make use of network functionality through open, standardised, secure, extensible and scalable interfaces. Applications see the network functionality offered to them as a set of Service Capability Features (SCFs) in the OSA APIs. These SCFs provide access to the network capabilities on which the application developers can rely when designing their applications. The OSA APIs are independent of where or which network capabilities are implemented in the network, and of vendor-specific solutions and programming languages.

Two different types of SCFs can be distinguished:

- Framework SCF: this provides commonly used utilities, necessary for the non-framework service capability features to be accessible, secure, resilient and manageable;
- Non-Framework SCFs: these enable the applications to make use of the functionality of the underlying network capabilities (e.g. User Location service capability features).

The feature defines the OSA interface for the communication between Applications and SCFs:

Framework SCFs:

- Authentication
- Authorisation
- Registration
- Discovery
- Notification

Non-Framework SCFs:

- Session Control
- Security/Privacy
- User Location
- User Status
- Terminal Capabilities
- Information Transfer
- User Profile Management
- Charging

16 Billing & Charging

Acronym: OAM-CH

References for WI "Charging"

Document	Title/Contents
WIDs	
SP-99271	Charging and accounting
SP-99581	SA5 Year 2000 Work plan
Impacted Specifications	
None	None
New Dedicated Specifications	
22.115	Service Aspects Charging and billing
23.121	Architectural requirements for Release 1999
32.005	Telecommunications Management; Charging and billing; 3G call and event data for the Circuit Switched (CS) domain
32.015	Telecommunications Management; Charging and billing; 3G call and event data for the Packet Switched (PS) domain

This feature creates the Charging framework to be followed by the 3G Telecom Management standardisation. The main aspects of this work are the transfer of Circuit and Packet Switched Charging from GSM to UMTS/3G, accommodating the UMTS/3G-specific respectively Additional functionality.

17 Operations, Administration, Maintenance and Provisioning (OAM&P)

Acronym: OAM

References for WI "OAM&P"

Document	Title/Contents
WIDs	
SP-99272	Fault management
SP-99273	Configuration management
SP-99274	Performance management
SP-99581	SA5 Year 2000 Work plan
Impacted Specifications	
12.03	Security Management
12.04	Performance data measurements
12.71	Location Services (LCS); Location services management
New Dedicated Specifications	
32.101	Telecommunication management; Principles and high level requirements
32.102	Telecommunication management; Architecture
32.104	3G Performance Management
32.106-1	Telecommunication management; Configuration Management (CM); Part 1: Concept and

	requirements
32.106-2	Telecommunication management; Configuration Management (CM); Part 2: Notification Integration Reference Point (IRP): Information Service
32.106-3	Telecommunication management; Configuration Management (CM); Part 3: Notification Integration Reference Poin (IRP)t; Common Object Request Broker Architecture (CORBA) solution set
32.106-4	Telecommunication management; Configuration Management (CM); Part 4: Notification Integration Reference Poin (IRP); Common Management Information Protocol (CMIP) solution set
32.106-5	Telecommunication management; Configuration Management (CM); Part 5: Basic Configuration Management Integration Reference Point (IRP): Information model (including Network Resource Model NRM))
32.106-6	Telecommunication management; Configuration Management (CM); Part 6: Basic Configuration Management Integration Reference Point (IRP): Common Object Request Broker Architecture (CORBA) solution set
32.106-7	Telecommunication management; Configuration Management (CM); Part 7: Basic Configuration Management Integration Reference Point (IRP): Common Management Information Protocol (CMIP) solution set
32.106-8	Telecommunication management; Configuration Management (CM); Part 8: Name convention for Managed Objects
32.111-1	Telecommunication management; Fault Management; Part 1: 3G fault management requirements
32.111-2	Telecommunication management; Fault Management; Part 2: Alarm Integration Reference Point (IRP): Information Service
32.111-3	Telecommunication management; Fault Management; Part 3: Alarm Integration Reference Point (IRP): Common Object Request Broker Architecture (CORBA) solution set
32.111-4	Telecommunication management; Fault Management; Part 4: Alarm Integration Reference Point (IRP): Common Management Information Protocol (CMIP) solution set

This feature creates the OAM&P framework to be followed by the 3G Telecom Management standardisation and met by all other subsequent specifications - to be produced by all 3GPP TSGs (e.g. SA5, RAN O&M, GERAN O&M, etc. - pertinent to 3G Systems' Telecom Management).

- Telecom Mgmt - X.25 Decision; Add Security Section; IRP Framework
- Performance Mgmt – X.25 Consistency; synchronization; performance measurement parameter issues
- Configuration Mgmt
- Fault Mgmt
- Verify interoperation between S5 O&M and RAN O&M

18 Super Charger

Acronym: Super Charger

References for WI "Super Charger"

Document	Title/Contents
TP-000??	WI Sheet
Impacted Specifications	
21.905	3G Vocabulary
23.912	Technical Report on Super-Charger
23.007	Restoration Procedures
23.008	Organisation of Subscriber Data capabilities
23.012	Location Management Procedures
23.016	Subscriber Data Management: Stage 2
23.040	Technical Realisation of the Short Message Service (SMS); Point-To-Point (PP)
23.060	General Packet Radio Service; Stage 2
29.002	Core Network Protocols; Stage 3
New Dedicated Specifications	
22.140	MMS stage 1
23.140	MMS stage 2/3

The Super-Charger concept reduces the mobility management costs associated with inter-VLR and SGSN location updates.

The Super-Charger constitutes a change to the subscriber data management to reduce mobility management costs. However, the proposed enhancement does not require significant modifications of the GSM/UMTS standards.

The current subscriber data management philosophy is to cancel the subscriber data at the old MSC/VLR when the subscriber moves to a location area served by a different MSC/VLR. An alternative philosophy is to leave the subscriber data at the old MSC/VLR, which removes the need to use the cancel location procedure, figure 1. The HLR performs the normal insert subscriber data at the new MSC/VLR. The subscriber data at the old MSC/VLR is not maintained in any way. Therefore, no additional signalling is required.

The network benefits from this new philosophy when the subscriber roams to a previously visited MSC/VLR where the user's subscription data is already present. In this case, provided the subscription data is still valid then the need to perform the insert subscriber data procedure is removed, figure 2. Consequently, this philosophy reduces mobility management cost by reducing the volume of location update signalling.

The new philosophy is of most benefit in metropolitan areas where the density of MSC/VLRs is high to cope with the large number of subscriber and subscribers regularly commute between location areas served by different MSC/VLRs. Assuming the subscriber data has not been deleted or changed since the subscriber was last attached in the location area then the MSC/VLR has the option to use the subscriber data previously downloaded. However, the HLR will ultimately control data retention and updates in the MSC/VLR.

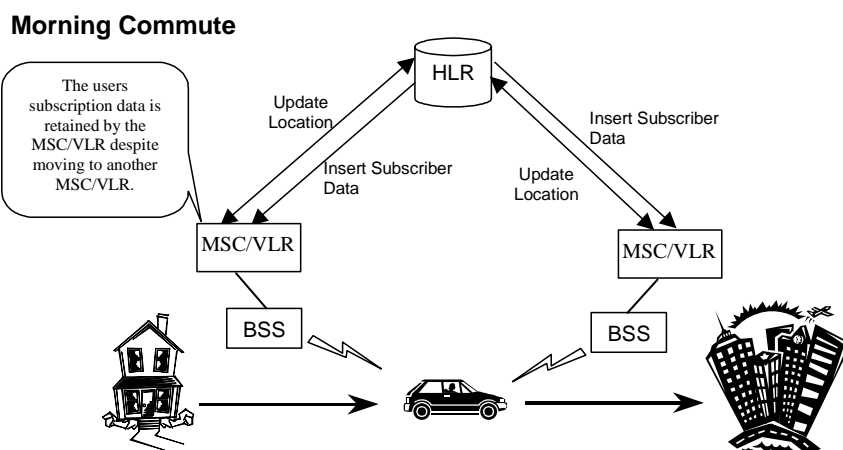

Figure 1: Morning Commute in a Super-Charged Network

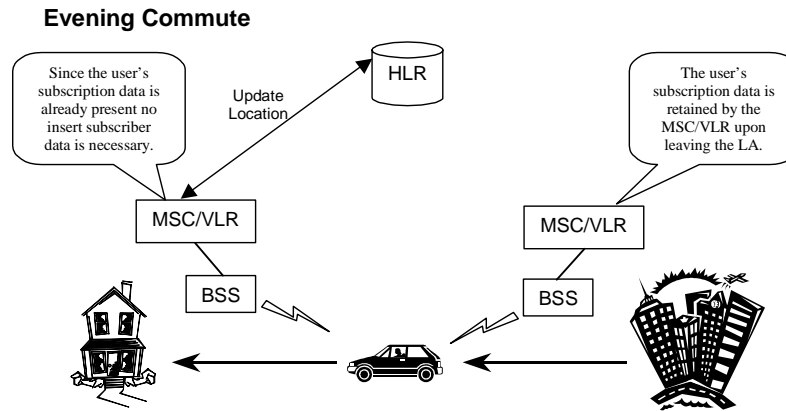

Figure 2: Evening Commute in a Super-Charged Network

In a Super-Charged network subscription data is retained by the previous network entity when the subscriber roams to a new network entity.

When a subscriber performs location updating in a Super-Charged network the HLR shall only cancel the subscription information at the previous network entity if it does not support the Super-Charger functionality. If the network entity to which the subscriber has roamed has retained subscription data from a previous visit then the HLR shall only send subscription data to the network entity if the retained subscription data is not consistent with the data stored by the HLR. If the HLR does not send subscription data to the serving network entity it shall treat the retained subscription data as valid.

The Super-Charger concept is equally applicable to packet services.

19 Follow me

Acronym: Follow me

References for WI "Follow me"

Document	Title/Contents
NP-000??	WI Sheet
Impacted Specifications	
TS 21.905	3G Vocabulary
TS 22.004	General on Supplementary Services
TS 22.030	Man-Machine Interface (MMI) of the Mobile Station (MS)
TS 22.082	Call Forwarding (CF) supplementary services - Stage 1
TS 22.090	Unstructured Supplementary Services Data (USSD)- Stage 1
TS 22.094	Follow Me (FM) feature - Stage 1
TS 23.011	Technical realisation of Supplementary Services - General Aspects
TS 23.015	Technical realisation of Operator Determined Barring (ODB)
TS 23.082	Call Forwarding (CF) supplementary services - Stage 2
TS 23.090	Unstructured Supplementary Services Data (USSD)- Stage 2
TS 24.090	Unstructured Supplementary Services Data (USSD)- Stage 3
TS 29.002	Mobile Application Part (MAP)
New Dedicated Specifications	
TS 22.140	MMS stage 1
TS 23.140	MMS stage 2/3

Follow Me enables an initiating mobile subscriber A to have control over the Follow Me data of a remote party B. The remote party B is characterised by the remote number which is defined in the numbering plan of a PLMN operator. Initiating Subscriber A shall be able to manipulate the Follow Me data of remote party B such that subsequent calls destined for remote party B are forwarded to initiating subscriber A. In the case of Forced Erasure by an FM service supervisor, the initiating subscriber is allowed to erase the Follow Me data of a remote party who has been registered to a different initiating subscriber for the Follow Me application.

Follow Me is a PLMN specific feature and the control operations of FM are based on USSD. All messages between the MS and the mobile network and internal to the mobile network are USSD messages.

The present document deals with the control operations of FM in HLRA and Follow me Function Node (FFN). If the FFN is an HLR, the control of the requests for both FM and CFU services is specified (see subclause 4.3.2).

The functionality of forwarding calls for remote party B to initiating subscriber A (after successful registration of FM) is out of the scope of the present document. This functionality is the same as the functionality of the Call Forwarding Unconditional Supplementary Service applied to all telecommunication services of remote party B for which CFU is applicable.

NOTE 1: the "served mobile subscriber" in TS 22.094 corresponds to the "remote party" in the present document and the "forwarded-to subscriber" in TS 22.094 corresponds to the "initiating subscriber" in the present document.

NOTE 2: The forwarding of calls for remote party B to initiating subscriber A can be achieved by invoking the Call Forwarding Unconditional Supplementary Service or by making use of an equivalent operator specific service (e.g. via CAMEL).

The functionality of the control of Follow Me (registration, erasure, forced erasure and interrogation) is split between the HLR of the initiating subscriber A (HLRA) and the FFN of the remote party B (FFNb).

20 Electrical safety requirements and regulations

Acronym (if any): no acronym

References for WI " Electrical safety requirements and regulations "	
Document	Title/Contents
TP-000022	WI Sheet
New Dedicated Specifications	
TR 34.907	Electrical safety requirements and regulations

Under this work item a Technical Report has been created which provides the information on electrical safety requirements for Information and Technical equipment including 3G mobile phones in each country and region. The document summarises the difference between international standards and national standards relevant to IEC60950 and also refers to regulations with regard to the conformity assessment because each country has different standards from other countries in current situation. The document does not define any new electrical safety requirements.

21 Multi-mode UE issues

Acronym (if any): no acronym

References for WI " Multi-mode UE issues "	
Document	Title/Contents
TP-000022	WI Sheet
Impacted Specifications	
New Dedicated Specifications	
TR 21.810	Report on multi-mode UE issues; ongoing work and identified additional work
TR 21.910	Multi-mode UE issues; categories, principles and procedures

The concept of Multi Mode UEs has been discussed and proposals developed in other Working Groups have been brought together and analysed in two Technical Reports.

Multi-mode User Equipments categories have been identified. A description is provided about the consequences on roaming capabilities and service availability (e.g. handover) of such multi-mode Ues while roaming in various regions implemented with various network configurations. The latter objective consists of case studies for each of the possible scenarios in reference to existing specifications. In these studies it has

been important to make sure that no duplication of text has been made or that inconsistencies have been created between specifications.

22 Specific Absorbtion Rate (SAR) requirements and regulations in different regions

Acronym (if any): no acronym

References for WI " Multi-mode UE issues "	
Document	Title/Contents
TP-000022	WI Sheet
New Dedicated Specifications	
TR 34.925	Specific Absorbtion Rate (SAR) requirements and regulations in different regions

Under this work item a Technical Report has been created describing the Specific Absorbtion Rate (SAR) requirements and regulations in different regions. One can note that the document is not setting the requirements and regulations, instead it is reporting existing requirements and regulations.

23 Synchronisation & Object exchange

Acronym (if any): no acronym

References for WI " Synchronisation & Object exchange "	
Document	Title/Contents
TP-000022	WI Sheet
Impacted Specifications	
New Dedicated Specifications	
TR 27.903	Discussion of synchronisation standards
TS 27.103	Wide Area Network Synchronisation

The concept of Wide Area Synchronisation for 3GPP has been developed to allow data stored in the ME/USIM to be synchronised with the outside world.

First, TR 27.903 was created providing information on existing synchronisation protocols. It summarises proprietary and standard protocols relevant to current and future mobile communication devices. The document covers only synchronisation between end-user devices, desktop applications, and server-based information services. It does not refer to replication or synchronisation between enterprise databases.

After the analysis done within the above TR, TS 27.103 was created. This specification provides a definition of a Wide Area Synchronisation protocols. The synchronization protocol was based upon IrMC level 4. The document covers Wide Area Network Synchronisation between current and future mobile communication end-user devices, desktop applications and server-based information servers. It was designed s as a living document and, as such, it will evaluate new technologies (e.g. XML) for inclusion as they become readily available. (Please note that from Rel-4 onwards the IrMC was removed from 27.103 and replaced by SyncML.)

24 User Equipment Capability Requirements

Acronym (if any): no acronym

References for WI " User Equipment Capability Requirements "	
Document	Title/Contents
TP-000022	WI Sheet
Impacted Specifications	
New Dedicated Specifications	
TR 21.904	User Equipment Capability Requirements (UCR)

The Requirements for UE Capability have been brought together from other Working Groups, to provide an assessment of the necessary capabilities for a UE to “exist” in a 3GPP network, and also to provide certain services (e.g. speech, fax, SMS).

This document defines a baseline set of capability requirements that enable all terminals to "register" with all applicable 3GPP networks (depending on the availability of a appropriate subscription). It describes all the functions that a terminal must perform in order to "exist" within a 3GPP network. These functions are used to derive requirements for all aspects of terminal baseline capability. This document also identifies different service capabilities and the functions that a terminal must perform in order to access a service. The actual capabilities that a terminal must possess to meet these requirements are listed in the Annexes to this document and described in the referenced implementation specifications. This document introduces the concept of "service-less terminal" which can exist in the network but provides no user service. Although this is not a marketable terminal type it describes from the standardisation viewpoint a baseline set of capabilities to which specific service-related terminal capabilities can then be added.

25 Terminal interfaces

25.1 Terminal interfaces (AT commands for 3GPP)

Acronym (if any): no acronym

References for WI " Terminal interfaces (AT commands for 3GPP)"	
Document	Title/Contents
TP-000022	WI Sheet
Impacted Specifications	
TS 27.005	Use of Data Terminal Equipment - Data Circuit terminating Equipment (DTE - DCE) interface for Short Message Service (SMS) and Cell Broadcast Service (CBS) AT command set for 3G User Equipment (UE)
TS 27.007	

This work item is about AT commands for control of 3GPP MEs via an external TE, fully compatible with GSM AT commands. Several new AT commands e.g. to control ASCII services have been added.

TS 27.005 defines three interface protocols for control of SMS functions within a GSM mobile telephone from a remote terminal via an asynchronous interface. This specification considers the mobile termination to be a single entity. Other TSs describe the split of functionality between the mobile equipment and SIM.

TS 27.007 specifies a profile of AT commands and recommends that this profile be used for controlling Mobile Equipment (ME) functions and GSM network services from a Terminal Equipment (TE) through Terminal Adaptor (TA). The command prefix +C is reserved for Digital Cellular in ITU-T Recommendation V.25ter. This TS has also the syntax details used to construct these extended GSM commands. Commands from ITU-T Recommendation V.25ter and existing digital cellular standards (TIA IS-99 and TIA IS-135) are used whenever applicable. Some of the new commands are defined such way that they can be easily applied to ME of networks other than GSM.

25.2 Terminal interfaces (physical interfaces)

Acronym (if any): no acronym

References for WI " Terminal interfaces (physical interfaces)"

Document	Title/Contents
TP-000022	WI Sheet
New Dedicated Specifications	
TR 27.901	Report on Terminal Interfaces - An Overview

Under this work item several options for physical terminal interfaces have been evaluated. Finally, 3GPP concluded that 3GPP should not produce any technical specification for terminal interfaces other than the radio interface and the USIM interface. The SDOs could develop their own optional physical connector specification based on their market requirements.

25.3 Terminal interfaces (multiplexer)

Acronym (if any): MUX MS-TE

References for WI " Terminal interfaces (multiplexer)"

Document	Title/Contents
TP-000022	WI Sheet
Impacted Specifications	
TS 27.010	Terminal Equipment to Mobile Station (TE-MS) multiplexer protocol

This work item is about a Multiplexing protocol to allow a number of simultaneous sessions over the terminal interface. The TS defines a multiplexing protocol between a mobile station and a terminal. The multiplexing protocol can be used to send any data, for instance voice, SMS, USSD, fax etc. The present document describes the protocol, but not the commands or data transported with it.

26 Circuit Switched Bearer Services

Acronym: CS Data Bearers

References for WI "Description for Circuit Switched Bearers in UMTS "

Document	Title/Contents
	WI Sheet
N3-99151 (contained in NP-99285)	TSG-CN3 Work Item on the "Description for Circuit Switched Bearers in UMTS"
Impacted Specifications	
TS 27.001	General on Terminal Adaptation Functions (TAF) for Mobile Stations (MS)
TS 22.002	Circuit Bearer Services (BS) supported by a Public Land Mobile Network (PLMN)
TS 29.007	General requirements on interworking between the Public Land Mobile Network (PLMN) and the Integrated Services Digital Network (ISDN) or Public Switched Telephone Network (PSTN)
New Dedicated Specifications	
TS 23.910	Circuit Switched Data Bearer Services

Circuit switched data services and "real time" data services are provided for interworking with the PSTN/ISDN so that the user is unaware of the access network used (UMTS and GSM access network or handover between access networks). Both transparent (constant delay) and non-transparent (zero error with flow control) services are supported. These data services are designed to operate with minimum loss of data on handover between the GSM access network and the UTRAN.

The CS Bearers are applicable for the support of real-time applications, e.g. Fax and Video and also the GSM General Bearer Services (GBS) and interworking scenarios as specified in TS 22.002 (R99).

Both Asynchronous and Synchronous access modes are supported (if applicable) for:

- 3.1kHz Audio modems up to V.90 (0.3kbit/s-56kbit/s)
- V.110 UDI (0.3kbit/s-56kbit/s)
- X.31 flag stuffing UDI (2.4 kbit/s-56kbit/s)
- V.120 (1.2kbit/s-56kbit/s)
- Bit Transparent Mode (56kbit/s and 64kbit/s)
- PIAFS (29.2kbit/s and 58.4kbit/s).

27 Frame Tunnelling Mode (FTM)

Acronym: FTM

References for WI "Frame Tunnelling Mode (FTM) in GSM and UMTS"

Document	Title/Contents
	WI Sheet
N3-99181 (contained in NP-99285)	TSG-CN3 Work Item on "Frame Tunnelling Mode (FTM) in GSM and UMTS"
Impacted Specifications	
07.01 / 27.001	General on Terminal Adaptation Functions (TAF) for Mobile Stations (MS)
09.07 / 29.007	General requirements on interworking between the Public Land Mobile Network (PLMN) and the Integrated Services Digital Network (ISDN) or Public Switched Telephone Network (PSTN)
27.007	AT command set for 3G User Equipment (UE)
22.002	Circuit Bearer Services (BS) supported by a Public Land Mobile Network (PLMN)
New Dedicated Specifications	
	None

Frame Tunnelling Mode (FTM) is a generic term for HDLC (High-level Data Link Control) and HDLC-related transmission protocols, FTM is a type of the asynchronous non-transparent CS bearer service (as described in TS 22.002).

The Work Item FTM was for the new service in GSM and UMTS that provides a conversion of the asynchronous non-transparent data stream towards the mobile side and the synchronous data stream using X.31 flag stuffing on the fixed network side. This service can be used by asynchronous terminals to access ISPs providing synchronous access via ISDN.

28 Access to ISPs and Intranets – Wireless/Remote access to LANs

Acronym: Interworking with PDN (DHCP)

References for WI " Access to ISPs and Intranets – Wireless/Remote access to LANs "

Document	Title/Contents
	WI Sheet
N3-99069	TSG-CN3 Work Item on " Access to ISPs and Intranets – Wireless/Remote access to LANs "
Impacted Specifications	
29.061	Interworking between the Public Land Mobile Network (PLMN) supporting packet based services and Packet Data Networks (PDN)
New Dedicated Specifications	
	None

This Work Item introduces the access to an Intranet or ISP by running DHCP between the TE and a server in the Intranet/ISP domain. The corresponding interworking with the PDN is described in a new clause of TS 29.061.

At PDP context activation the MS requests an APN offering the DHCP service. The IP address of the PDP context is provisionally set to 0.0.0.0 as no IP address is allocated at this moment.

The TE runs a DHCP client, after the PDP context has been successfully activated, to retrieve the IP address and other configuration parameters from a DHCP server located in the Intranet/ISP domain. The PDP context is then updated through the GGSN-initiated modification procedure to reflect the newly allocated IP address.

A Packet Domain-specific DHCP Relay Agent is needed in the GGSN to allow for the correct routing of broadcast DHCP messages.

Part 3 – GSM Features

29 The Dual Transfer mode within GSM/GPRS

“Dual Transfer Mode” (DTM) is also known as "BSS co-ordination of Radio Resource allocation for class A GPRS services - GSM Radio Access " and "BSS co-ordination of Core Network Resource allocation for class A GPRS services -GSM-UMTS Core Network".

References for Work Items on DTM

Document	Title/Contents
2-99-1780	WI Description
Impacted Specifications	
TS 04.18	Mobile radio interface layer 3 specification; Radio Resource Control Protocol.
TS 04.60	Mobile Station (MS) - Base Station System (BSS) interface; Radio Link Control/ Medium Access Control (RLC/MAC) protocol.
TS 23.060	General Packet Radio Service (GPRS); Service description; Stage 2.
TS 05.01	Physical layer on the radio path; General description.
TS 05.02	Multiplexing and multiple access on the radio path.
TS 05.08	Radio subsystem link control.
TS 03.64	Overall description of the GPRS radio interface; Stage 2.
TS 08.08	Mobile-services Switching Centre - Base Station System (MSC - BSS) interface; Layer 3 specification.
TS 24.007	Mobile radio interface signalling layer 3; General aspects.
TS 24.008	Mobile radio interface layer 3 specification; Core Network Protocols; Stage 3.
New Dedicated Specifications	
TS 03.55	Dual Transfer Mode; Stage 2.

The definition of GPRS class A mode of operation in Releases '97/'98 was done assuming a total independence between the CS and PS domains. Thus the direct implementation of the standards would have resulted in mobile stations required to operate in two different frequencies simultaneously. To overcome this and allow a simultaneous existence of circuit-switched connection and packet-switched sessions within GSM/GPRS, the dual transfer mode was introduced in the Release'99.

One of the aim was for the user to be able to see a "UMTS class A service" in GSM coverage.

This was done by "associating" one or more packet-switched timeslot(s) to the circuit-switched timeslot, or even by sending packet-switched data and circuit-switched voice in the same timeslot, i.e. when half-rate speech is used.

To perform this association, the (GSM) Base Station Controller (BSC) needs to know the IMSI of the Mobile Station. Consequently, in a similar manner to UMTS, the A interface was modified so that the BSC can be made aware of the IMSI associated with each SCCP connection towards the MSC. With this information, the BSC can do the co-ordination of resources allocated to the circuit-switched and packet-switched domains.

30 General Packet Radio Service (GPRS) - radio part

References for WI " General Packet Radio Service (GPRS) - radio part (R99)"

Document	Title/Contents
Impacted Specifications	
03.64	Overall description of the GPRS radio interface; Stage 2
04.08	Mobile radio interface layer 3 specification
04.60	MS-BSS Interface; Radio Link Control / Medium Access Control (RLC/MAC) protocol
05.02	Multiplexing and multiple access on the radio path
05.05	Radio transmission and reception
05.08	Radio subsystem link control
05.10	Radio subsystem synchronization
05.50	Background for Radio Frequency (RF) requirements
11.21	BSS Radio aspects

In the year 1999 a number of essential corrections were made on the GPRS feature already existent since Release 97 (e.g. on Downlink Power Control, Timing Advance procedure, Cell reselection delay time, PBCCH scheduling, PTCCCH mapping, etc.).

A number of specifications were impacted, the most important among them being listed in the following Table.

31 GSM on 400 MHz Frequency Band

References for WI " GSM on 400 MHz Frequency Band "

Document	Title/Contents
Work_Items_History	Updated WI Sheet
Tdoc SMG2 507/00	GSM in the 400 MHz bands
Impacted Specifications	
02.17	SIM Functional characteristics
03.22	Functions related to Mobile Station (MS) in idle mode and group receive mode
03.30	Radio network planning aspects
04.04	Layer 1; General requirements
04.18	Mobile radio interface layer 3 specification; RRC Protocol
04.60	MS-BSS Interface; Radio Link Control / Medium Access Control (RLC/MAC) protocol
05.01	Physical layer on the radio path; General description
05.02	Multiplexing and multiple access on the radio path
05.05	Radio transmission and reception
05.08	Radio subsystem link control
05.10	Radio subsystem synchronization
05.50	Background for Radio Frequency (RF) requirements
08.18	BSS SGSN - BSS GPRS Protocol (BSSGP)
08.58	(BSC - BTS) interface; Layer 3 specification
24.008	Mobile radio interface layer 3 specification; Core Network Protocols Stage 3
27.007	AT command set for User Equipment (UE)
11.21	BSS Radio aspects

At SMG#26 (Helsinki, 22-26 June 1998), a proposal was made to study the possibility of deploying GSM within frequency bands currently used for analogue cellular systems. ETSI TC SMG noted that operators who may wish to migrate from analogue cellular systems to GSM would be in both CEPT member countries and non-member countries. SMG#26 agreed that SMG2 would perform a feasibility study into this proposal. SMG2#29 (25 - 28 January 1999) completed the feasibility study, which proved that down banded GSM is technically a feasible solution and TC SMG#28 accepted GSM450 to be taken as a Work Item under TC SMG and to be included into GSM release 1999. In TC SMG#29, due to the clarified scope, the work item was renamed to be "GSM in the 400 MHz bands".

While 1800 was added to the base GSM specification some modifications were done to make the set of specifications less band dependent. As a continuation for this process the possibilities to further adapt the specifications toward band free format were considered where appropriate in this work item.

GSM 400 systems are targeted to offer large coverage in rural areas.

The work item GSM in the 400 MHz bands includes a support for cell ranges up to 120 km by enabling two more bits in Timing Advance Information Element.

GSM 400 systems are specified for two frequency allocations. Primary utilisation will be allocations around 450 MHz. For some countries allocations around 480 MHz is possible. Thus the systems are specified for operation in the following frequency bands:

GSM 450 Band

-450.5 – 457.5 MHz: mobile transmit, base receive;

-460.5 – 467.5 MHz: base transmit, mobile receive;

GSM 480 Band (this band is not discussed in this first draft further)

-479 – 486 MHz: mobile transmit, base receive;

-489 – 496 MHz: base transmit, mobile receive;

with a carrier spacing of 200 kHz.

Consequently, if we call $F_l(n)$ the n th carrier frequency in the lower band, and $F_u(n)$ the n th carrier frequency in the upper band, we have

$$- F_l(n) = 450.6 + 0.2*(n-125) \quad (\text{MHz}) \quad (125 \leq n \leq 159)$$

$$- F_u(n) = F_l(n) + 10 \quad (\text{MHz})$$

The value n is called the Absolute Radio Frequency Channel Number (ARFCN).

It is reasonable to assume that BTS heights in rural area are higher than in urban area thus minimum coupling loss (MCL) 65 dB is valid assumption in rural areas.

The adoption of GSM 900 or EGSM 900 radio frequency requirements to GSM 450 systems with minimal changes make it easy to adapt standard GSM technology.

It may be necessary to recommend to utilise lower output power at 450 band BTSs in dense urban area if MCL can be very small (i.e. low antenna heights).

There are two possible cases, i.e. coordinated and uncoordinated case.

Coordinated case

In coordinated case BTS wideband noise requirement are fulfilled with both GSM 900 and GSM 450 systems and thus there is no need to change the specification for BTS TX mask.

Worst case scenario requirements for MS wideband noise are tighter than for BTS. Since the table entries in GSM 05.05 are relative, as the level of the transmitter is reduced, the absolute specification becomes tighter. For coordinated MS to BTS interference it is to be noted that power control works and MS is powered down. For MS close to BTS it is relevant to expect that minimum MS TX power is used and thus introduced wideband noise is reduced accordingly down to -43 dBm at 600 kHz distance. Still there is a gap of 11 dB in GSM 900 scenarios and specification.

Probabilities of this scenario are low and actually allowing this to happen is not practical cellular planning. Users which operate with full power and still close to sensitivity level locate in the edge area of very large cells may be blocked by low power users operating very close to BTS. In other words blocking of some users at cell edge would require large cells in dense urban areas with very small handover margin. In sensible cellular planning these should be contradictory occurrences. Thus it was felt that there is no need to make specification too tight because of speculation of some unpractical occurrences.

Uncoordinated case

The theoretical worst case uncoordinated scenarios are missed quite a lot; this was situation also in higher bands even now the mismatch is about 6 dB worse than in GSM 900: in practice, this situation is very rare. Firstly it is improbable that uncoordinated scenario should happen in narrowband. Secondly the theoretical calculations are done while MS close to disturbing BTS operates at sensitivity level which is not a common situation.

If uncoordinated scenarios are planned it may be decided by the operators that in dense urban areas where MCL may reach low values maximum power level is reduced by 6 dB in respect to those used in GSM 900 case. Still due to link budget gain low powered GSM 450 systems would offer equal coverage than GSM 900 system. Down powering of system is a natural choice anyway in urban areas where cellular planning is capacity driven rather than targeting to large cells.

As a conclusion it is seen unnecessary to do any changes to existing GSM 900 modulation mask while it is adapted to GSM 450 systems.

[See Tdoc SMG2 190/99 and 595/99 for further info].

32 Enhanced Data rates for GSM Evolution (EDGE)

Since Dec 1996 SMG set up work item 184: "Improved data rates through optimized modulation".

In December 1997 a Feasibility study Version 1.0 was made available from SMG2, and approved at ETSI TC SMG#24, two new work items were approved, i.e. EDGE BSS, EDGE NSS.

EDGE Network sub system (NSS)

EDGE Basestation sub system (BSS)

In mid-1998 SMG2 #26 selected 8-PSK (Phase Shift Keying) as a new up and downlink modulation.

Within the end of 1998, EDGE specification GSM 10.59 "Enhanced Data rates for GSM Evolution (EDGE) Project scheduling and open issues for EDGE", a fundamental specification containing all the EDGE service requirements, was endorsed by ETSI TC SMG.

SMG1 approved CR for TS 02.34 and TS 02.60 introducing EDGE, with the requirement that Circuit Switched services should be provided with EDGE both for transparent and nontransparent mode.

EDGE Release 1999 work.

With the introduction of EDGE in GSM phase 2+ existing services like GPRS and HSCSD are enhanced by offering a new physical layer. The services itself are not modified; therefore, EDGE was introduced in the existing specifications and stage descriptions rather than creating new ones.

Enhanced Data Rates for GSM Evolution (EDGE) was developed in two phases, Phase 1 in Release 1999 and Phase 2 after Release 1999; Phase 1 EDGE includes EGPRS Phase 1, ECSD Phase 1, EGPRS COMPACT and Support for EGPRS in ANSI-136 networks.

Acronyms:

EDGE Enhanced Data rates for GSM Evolution

EGPRS Enhanced GPRS

ECSD Enhanced ECSD

COMPACT Deployment of services in spectrum below 1 MHz

GSM 10.59 "Project scheduling and open issues for EDGE"

This specification incorporates a rather complete set of requirements, references, provisions from other publications, etc., which are essential to understand the development of EDGE. EDGE Service requirements are given in Annex 4 of GSM 10.59. EDGE Radio requirements are given in Annex 5 of GSM 10.59.

See also in particular:

- TDOC SMG2 331/97: "EDGE feasibility study Version 1.0"
- TDOC SMG 1147/97: "Work item description for EDGE – NSS"
- TDOC SMG 1148/97: "Work item description for EDGE – BSS"
- TDOC SMG2 872/99: "EDGE Compact and support for E-GPRS in ANSI-136 networks"

EDGE uses new modulation techniques in order to evolve data services in GSM reusing as much of the physical layer as possible. Two work items were identified to introduce EDGE into the existing GSM system, i.e. EDGE Network sub system (NSS) and EDGE Basestation sub system (BSS).

The EDGE BSS work item provides a platform to employ new modulation techniques, whereas the EDGE NSS work item defines the network changes to facilitate the physical layer. According to the work item descriptions EDGE provides two phases:

32.1.1 Phase 1 EDGE

The first phase EDGE standards specify the Enhanced GPRS (EGPRS) and Enhanced CSD (ECSD) work items; the new physical layer based on 8-PSK modulation is introduced and EGPRS and ECSD will facilitate the new modulation in single and multi slot constellation.

For ECSD the maximum user rate will be limited to 64 kbps.

No tight link is defined between 8-PSK and GMSK classes.

Outstanding specifications for EDGE Ph 1 (EGPRS, ECSD) are:

TS number	Title
03.30	Radio Planning aspects
05.10	Radio Subsystem synchronization
05.50	Background for RF requirements
11.26	Repeaters

32.1.2 Phase 2 EDGE

Phase 2: provides real time services not included in phase 1 employing the new modulation techniques; due to the substantial changes required for EDGE phase 2, those issues were handled in a brand new project plan (GERAN).

EDGE phase 2 would provide:

Real time services Based on an IP network applications like voice over IP, mixed bearer with different QoS parameters and video

High quality / capacity speech

High quality speech using the AMR wide band codec or the usage of half rate channels using the existing AMR codecs.

Multi call / Multimedia call

The provision of a simultaneous data and voice connection

Integrated IP network with integrated radio access for voice and data, IP based call control and IP borne traffic bearers as far as practical.

Alignment of UMTS and GSM/EDGE RANs.

33 Enhanced GPRS (EGPRS)

Acronym: EGPRS

References for WI " Enhanced GPRS"

Document	Title/Contents
Impacted Specifications	
02.60	GPRS Service Description; Stage 1
03.60	GPRS Service Description; Stage 2
03.64	Overall description of the GPRS radio interface; Stage 2
04.08	Mobile radio interface layer 3 specification
04.18	Mobile radio interface layer 3 specification; RRC Protocol
04.60	MS-BSS Interface; Radio Link Control / Medium Access Control (RLC/MAC) protocol
05.01	Physical layer on the radio path; General description
05.02	Multiplexing and multiple access on the radio path
05.03	Channel coding
05.04	Modulation
05.05	Radio transmission and reception
05.08	Radio subsystem link control
11.21	BSS Radio aspects

With the introduction of EGPRS, bitrates approximately three times higher than for standard GPRS will be enabled.

The architectural impacts of EGPRS are related to the GPRS Packet Control Unit (PCU) and Channel Codec Unit (CCU). The GPRS specification allows the placement of the PCU either in the BTS, BSC or GSN, the CCU is always placed in the BTS. When the PCU is placed remote to the BTS, information between the CCU and the PCU is transferred in PCU frames. The CCU may control some of the functions in the remote PCU and vice versa through inband signalling using the PCU frames.

The functions of the CCU are the channel coding, including FEC and interleaving; and also the radio channel measurement functions, including received quality level, received signal level and information related to timing advance measurements. The PCU is responsible for LLC PDU segmentation and re-assembly, ARQ (Automatic Repeat reQuest) functions (including RLC block ACK/NACK), PDCH scheduling, channel access control, and radio channel management functions.

GPRS and EGPRS employ the same physical layer, except for the PDCH. In the case of EGPRS, the modulation format is inherently signalled by the rotation factor of the training sequences as specified in GSM 05.04 and GSM 05.02, enabling blind detection in the receiver. The Radio Block structure for data transfer is different for GPRS and EGPRS, whereas the same Radio Block structure is used for control messages. For detailed definition of radio block structure, see GSM 04.60. Other changes included the introduction of ARQ, Incremental Redundancy mechanism, new MCS (Modulation and Coding Schemes). Eight new modulation and coding schemes, MCS-1 to MCS-8, were defined for the EGPRS packet data traffic channels. For all EGPRS packet control channels the corresponding GPRS control channel coding is used. Coding schemes MCS-1 to MCS-8 are mandatory for MSs supporting EGPRS. A network supporting EGPRS may only support some of the MCSs. The selection of MCS is controlled by the network. Transmission and reception data flows are same for GPRS and EGPRS, except for EGPRS MCS-8 and MCS-7, where four normal bursts carry two RLC blocks (one RLC block within two bursts). Type II hybrid ARQ is mandatory in EGPRS MS receivers and the associated performance requirements are specified in GSM 05.05.

EGPRS shall support both a pure link adaptation mode and a combined link adaptation and incremental redundancy mode.

The incremental redundancy mode requires no extra signalling between the CCU and PCU compared to the link adaptation mode. The incremental redundancy mode however requires an enhanced CCU functionality. RLC/MAC protocol is the most affected by EDGE.

Introduction of EGPRS also has an impact on Radio Resource Management (RR), Mobility Management (MM), and Session Management (SM). Changes of RR, MM and SM affect GSM 04.08 and 04.60.

An extended Channel Coding Command (CCC) is required for EGPRS since there are 8 different MCSs. In addition to this, an extra 'retransmission resegment' field (1 bit) should be sent along with this command. This field tells the MS whether it should resegment retransmissions to an MCS close to the one indicated in the CCC (e.g. used in LA mode or when memory shortage in BS in IR mode), or stick to the initially used MCS (used in IR mode when memory is available).

EGPRS will also require a modified/extended link quality measurement report.

For services where delay is the most crucial quality parameter, but some errors are acceptable, e.g. for some real time services, the retransmissions associated with the acknowledged mode will simply be unacceptable,

since the delay would be too large. Therefore EGPRS shall also be able to operate in unacknowledged mode, i.e. without retransmissions. To achieve an acceptable BLER or BER without ARQ, the link adaptation switching points in the proposed scheme are moved to yield the desired robustness in the non-acknowledged mode.

There are two modulation modes for PDCH in EGPRS: Linear 8-PSK and GMSK. GMSK is used as fall back when 8-PSK is not appropriate for the current channel conditions. There will be two classes of mobiles:

- Class 1: The two modulation modes can be used in the downlink, while only GMSK is used in the uplink.
- Class 2: The two modulation modes can be used both on up- and downlink.

Other channels than PDCH is always modulated with GMSK.

The first downlink block in each multiframe must be modulated with GMSK if a GPRS terminal is allocated on the same timeslot.

GSM 05.03 changes were necessary for channel coding, puncturing, interleaving, CRC and burst mapping.

See Tdoc SMG2 657/99 "EDGE: Concept Proposal for Enhanced GPRS"

34 GSM Mobile Number Portability EURO MNP/ North American MNP

[ONLY REQUIREMENTS LISTED HERE. STAGES 2 AND 3 ASPECTS STILL NEED TO BE CHECKED]

Acronym: MNP

References for WI " MNP"

Document	Title/Contents
WI	Roll-over WI from R98 (02.66)
22.066 v 3.2.0	Support of Mobile Number Portability (MNP); Stage 1
CR 22.066-001	Editorial changes for alignment (Approved at SP-05)
CR 22.066-002	PCS-1900 Service Provider Number Portability impacts for Mobile Number Portability (Approved at SP-07)
CR 22.066-003	North American Service Provider Number Portability impacts for Mobile Number Portability (Approved at SP-08)

This feature consisted of the requirements for Mobile Number Portability (MNP), which comprises the ability for a mobile subscriber to change digital mobile subscription networks within the same country whilst retaining their original DN or DNs.

North American GSM Number Portability (NAGNP) is the ability for a subscriber to change subscription between North American GSM networks and other subscription networks within an FCC regulated geographical area within North-America.

The IMSI is not ported, hence the recipient mobile network of the porting process will issue a new IMSI for the ported subscription. The porting process may, but need not, include a change in service provider.

The ported subscriber can use exactly the same services as non-porting customers in the same subscription network. That is, whether the DN of a subscriber belongs to a subscription network or is ported to the subscription network shall have no influence on the services offered to the customer by that subscription network.

The services offered by the number range owner network and/or the donor network have no influence on the services offered by the subscription network. When a subscriber ports a DN to a new network then the donor network no longer provides support for the services of the ported number (this includes supplementary and value added services).

NOTE: This also implies that if a service supported in the donor network is not available on the recipient network then number portability mechanisms need not provide that service for the ported subscriber.

A network can be a donor of numbers and a recipient of numbers. A DN can be ported more than once; a ported number can be ported back to its number range owner network. Even after multiple portings, the technical solution shall involve only the number range owner network and recipient network.

The solution for MNP/NAGNP shall have a minimal adverse effect upon the quality of service offered to ported and non-ported subscribers. It may be the case that the quality of service for ported and non-ported subscribers differs slightly (e.g. due to additional call set-up delay).

Any additional delay in call set-up to ported numbers shall be minimised.

The process of porting a number may involve a disruption in service to the customer.

The technical implementation of the support of MNP/NAGNP in a network must not impede number availability and efficient use of numbers.

The technical implementation for the support of MNP/NAGNP shall not involve loss of functionality in the number range owner, donor or subscription network.

The technical implementation of MNP/NAGNP shall support optimisation of the use of network and inter-network resources so as to minimise costs associated with transport of traffic and/or appropriate signalling and/or processing activities (e.g. optimal routing).

In addition, for the porting process an efficient and effective way is needed to exchange porting information between all types of network operators.

The R99 work was based on the R98 TS 02.66. The only value added to R99 was the addition of requirements for North American Service Provider Number Portability impacts in CR 003. It should be noted that CR 002 is a mirror CR for one applied to R98.

35 Enhanced Circuit Switched Data (ECSD)

Acronym: ECSD

References for WI " Enhanced Circuit Switched Data"

Document	Title/Contents
Impacted Specifications	
04.04	Layer 1; General requirements
04.08	Mobile radio interface layer 3 specification
04.18	Mobile radio interface layer 3 specification; RRC Protocol
04.60	MS-BSS Interface; Radio Link Control / Medium Access Control (RLC/MAC) protocol
05.01	Physical layer on the radio path; General description
05.02	Multiplexing and multiple access on the radio path
05.03	Channel coding
05.04	Modulation
05.05	Radio transmission and reception
05.08	Radio subsystem link control
08.08	(MSC - BSS) interface; Layer 3 specification
08.58	(BSC - BTS) interface; Layer 3 specification
08.60	Inband control of remote transcoders and rate adaptors for Enhanced Full Rate (EFR) and full rate traffic channels

ECSD will support both transparent and non-transparent services, up to 64 kbps and 57.6 kbps respectively. The user data rates are limited in Phase 1 ECSD specifications to 64 kbps. This means that the maximum data rates are not increased from the rates supported in current GSM. On the other hand, the same services are achievable with smaller number of time slots and relatively simple MS implementation making them more attractive to various data applications.

ECSD will support interworking with audio modems and ISDN services on various rates. Group 3 fax services are not expected to be supported with ECSD, because existing GSM channels are adequate for G3

fax support. If the digital extension of G3 and G4 fax is more widely adopted in the future, the fax services can be reconsidered.

One of the main applications for ECSD are the video applications. Besides data rates there are other requirements for video transmission: video services usually include several components, each of them with varying QoS requirements. Figures below show two concepts in terms of QoS of providing video telephony service. The differences between the concepts are in the way of ensuring the QoS for different components: audio, video and data.

For non-transparent (NT) data, BER < 10⁻³ requirement is assumed. Corresponding value for transparent (T) data is BER < 10⁻⁴...10⁻⁵.

The ECSD architecture is largely based on HSCSD transmission and signaling. This ensures a minimum impact on existing specifications.

New parameters are required in signaling messages due to new modulation and channel coding schemes, but the signaling mechanism is the same as in HSCSD. Also fall back to existing HSCSD and single slot data services is supported in case the network/MS has no enhanced service support.

Link adaptation (LA) between channel coding schemes in 8-PSK modulation and between GSMK and 8-PSK coding schemes require new algorithms in BSC. Link adaptation is not a mandatory feature in current GSM, but particularly in high data rate call using transparent mode connection LA becomes essential in order to provide the good enough service over large coverage areas.

Link adaptation algorithms used depend on the service data rates supported in the network and they are not specified in GSM specifications.

The required C/I for both GSMK and 8-PSK modulation with different RX_QUAL values (0-7) shows that the step size between quality classes is about 2 to 4 dB and dynamic range is about 20 dB for both modulations. Link simulations show that even C/I of 25 dB is enough in 38.8 kbps service for coded BER of 10⁻⁵. In practice it is very difficult to achieve higher C/I values than 30 dB. On the other hand, in the lower end C/I of 10 dB does not provide good enough service for 29 kbps. This would imply that the dynamical range in current measurements is sufficient for 8-PSK and link adaptation to GSMK should be performed well before the quality of the connection falls as low as this.

In practice, the granularity with BER based reporting and use of three bits for RX_QUAL levels, as in current GSM, is enough for covering the operative quality range.

Basically it could be possible to improve the link adaptation performance by replacing BER with C/I based reporting and introducing new measurement metrics like C/I variance used in GPRS. Including RX_LEV reports from more than six neighboring cells could also improve the performance of the link adaptation particularly for multi-band mobiles. These enhancements, however, require more drastic changes in signaling and could be seen as a general improvement to circuit switched measurements rather than EDGE specific change.

See Tdoc SMG2 670/99 "ECSD Concept Evaluation".

Part 4 - WIs applicable to other system(s)

36 EDGE Compact

Acronym: EDGE Compact

References for WI "EDGE Compact"

Document	Title/Contents
Impacted Specifications	
03.22	Functions related to Mobile Station (MS) in idle mode and group receive mode
03.30	Radio network planning aspects
03.64	Overall description of the GPRS radio interface; Stage 2
04.03	MS - BSS interface; Channel structures and access capabilities
04.04	Layer 1; General requirements
04.08	Mobile radio interface layer 3 specification
04.18	Mobile radio interface layer 3 specification; RRC Protocol
04.60	MS-BSS Interface; Radio Link Control / Medium Access Control (RLC/MAC) protocol
05.01	Physical layer on the radio path; General description
05.02	Multiplexing and multiple access on the radio path
05.03	Channel coding
05.04	Modulation
05.05	Radio transmission and reception
05.08	Radio subsystem link control
05.10	Radio subsystem synchronization
05.50	Background for Radio Frequency (RF) requirements
08.08	(MSC - BSS) interface; Layer 3 specification
08.58	(BSC - BTS) interface; Layer 3 specification
08.60	Inband control of remote transcoders and rate adaptors for Enhanced Full Rate (EFR) and full rate traffic channels
11.11	Mobile Equipment (SIM - ME) interface
11.21	BSS Radio aspects
24.008	Core Network Protocols; Stage 3

In January 1998, the ANSI-1368 TDMA community through the Universal Wireless Communication Consortium (UWCC) and TIA TR45.3 evaluated and adopted EGPRS as a key part of its high speed data evolution. Consequently, a large part of EGPRS was incorporated as "136 High Speed (136HS)" into the TDMA IMT-2000 proposal called "UWC-136". There were two key characteristics that 136HS allowed; data rates up to 384 kbps, and initial deployment in less than 1 MHz of spectrum. The TDMA Community has studied how to further enhance 136HS such that it would be closer to ETSI-EGPRS to better facilitate global roaming, while also keeping the desire for initial deployment in less than 1 MHz of spectrum. The result of this effort is the "COMPACT" proposal.

COMPACT can be deployed in as little as 600 kHz (+guard) of spectrum, and looks as a pure overlay system to an existing ANSI-136 network. As such, COMPACT is independent of the ANSI-136 system, which facilitates roaming of EGPRS only mobile stations, as well as it allows operators to deploy different infrastructure vendors for their data solution from their voice network.

For operators, which are not as spectrally challenged, the TDMA Community also supports the development of ETSI-EGPRS, which is referred to as "EGPRS Classic", requiring 2.4 MHz of initial spectrum. The support of both COMPACT and EGPRS Classic under what is called EGPRS-136 represents a powerful solution towards the convergence of GSM and ANSI-136 systems worldwide.

⁸ In this document ANSI-41 and ANSI-136 are referring to the ANSI standards TIA/EIA-41 and TIA/EIA-136, respectively.

Integration of GPRS with ANSI-136 is logically accomplished by the addition of the GPRS network nodes SGSN and GGSN to the ANSI-41 circuit-switched network.

EGPRS (i.e. EGPRS Classic) terminals on the 850 or 1900 MHz band will also support COMPACT to facilitate roaming.

COMPACT terminals would also support EGPRS Classic to facilitate roaming.

The concept proposal for EDGE compact has been presented to SMG2 and the EDGE workshop in May and June 1999. The document TDOC SMG2 EDGE 322/99, "EDGE compact concept proposal" reflected the latest status of the discussion: strong interest existed for packet based services, to be implemented in the short term for the "compact mode".

The idea is that a mobile supporting TDMA band (850 and 1900) shall support both Compact and Classic EDGE (in USA).

EDGE Compact also includes specification information for mixed mode operation at 850 and 1900 MHz. (MXM 850 and MXM 1900).

850 MHz and 1900 MHz mixed-mode is defined as a network that deploys both 30 kHz RF carriers and 200 kHz RF carriers in geographic regions where the Federal Communications Commission (FCC) regulations are applied.

EDGE Classic : same as EDGE with 4x12 except BCCH on TN0

EDGE Compact: BS sync + modified control channel

EDGE Compact: PSCH is different due to 52 multiframe structure. Cell reselection is modified: new measurement method. New broadcast information info on 200 khz for 30 khz voice page.

Under 20-25% load Edge compact performs better than Edge classic because of DTX.

37 GPRS phase 2 for PCS1900

See EDGE

38 Support for EGPRS in ANSI-136 networks

See EDGE Compact

Tdoc SMG2 826/99 "Work Item: "EDGE Compact and support for E-GPRS in ANSI-136 networks"

This document contains a proposed Work Item Description for a Work Item to harmonise the SMG work and GSM specification with the ongoing work in Universal Wireless Communications Consortium (UWCC) to introduce the support of EDGE and GPRS in ANSI-136 networks. The purpose of the work item is to ensure that the evolution of EDGE and GPRS are synchronised in ETSI and UWCC.

The work item includes all necessary changes for the support of the so-called EDGE Compact concept, i.e. an EDGE implementation in a limited frequency band, and the interaction with the ANSI-41/136 network. It also includes the changes for the support of roaming between EDGE Compact and classic Edge (EDGE Classic) implementations.

Even if this work item is mainly proposed to meet the requirements by UWCC it also makes it possible for implementation of EDGE Compact in other frequency bands with limited spectrum, e.g. GSM400. Also the work item makes it possible to use GSM on 850 MHz, which is in the spirit of the band free operation.

The Universal Wireless Communications Consortium (UWCC) has decided to use EDGE and GPRS as basis for their packet data service in ANSI-41/136. Some of the operators have limited spectrum available (in 850 and 1900 MHz) for this and modifications to the EDGE technology, EDGE Compact, has been proposed. This proposal supports implementation of E-GPRS in less than 1 MHz spectrum.

The EDGE Compact concept was developed by UWCC for packet data service in 850 and 1900 MHz spectrum. However it is possible to implement it in any of the GSM frequency bands. Therefore it will be considered if a wider set of EDGE services could be provided, this does not delay the introduction of Edge Compact Release 99.

The work item includes the work on four different areas:

- Support of GSM on 850 MHz
- EDGE Compact
- Signalling support for interaction with the ANSI-41/136 network
- Support for roaming between E-GPRS and GPRS136HS EDGE

The work item is linked to the work items on GPRS and EDGE work, e.g. the EDGE NSS work on ANSI-41 tunnelling. Also the work item on GSM400 operation is linked since a new frequency band, 850 MHz, is introduced. The work in GSM400 work item is re-used for the work on 850 MHz support.

EDGE has been selected by ANSI 136 as high speed data extension. The EDGE radio interface has been designed as large extent as possible to achieve a common standard to be used in GSM and ANSI 136 high speed data.

39PHS Internet Access Forum Specification (PIAFS)

Acronym: PIAFS

References for WI " support of PIAFS in UMTS "

Document	Title/Contents
	WI Sheet
N3-991491 (contained in NP-99285)	TSG-CN3 Work Item on " support of PIAFS in UMTS "
Impacted Specifications	
07.01 / 27.001	General on Terminal Adaptation Functions (TAF) for Mobile Stations (MS)
09.07 / 29.007	General requirements on interworking between the Public Land Mobile Network (PLMN) and the Integrated Services Digital Network (ISDN) or Public Switched Telephone Network (PSTN)
27.007	AT command set for 3G User Equipment (UE)
22.002	Circuit Bearer Services (BS) supported by a Public Land Mobile Network (PLMN)
New Dedicated Specifications	
	none

PIAFS is one type of CS bearer data service (as described in TS 22.002).

The PIAFS service is the data communication system provided by the well known Personal Handy Phone System (PHS) in Japan. This service needs to be continuously serviced by the UMTS system because of the following reasons.

Connection between PHS-MS and UMTS-UE is required.

Connection between UMTS-UE and existing TA (Terminal Adapter) for PIAFS is required. (TA for PIAFS is also popular in Japan.)

PIAFS itself, is an asynchronous circuit switched transmission protocol over ISDN 64Kbps unrestricted digital line and was originally standardized by PHS Internet Access Forum in Japan. (<http://www.infopro.or.jp/piaf/>). In 1999 there were 578000 PHS users and 10% of those used PIAFS.

This scope of the 3GPP R99 PIAFS work item is to allow PIAFS to be supported by the 3GPP network.

Part 5 - Features with no impact or minor impact on the system

40 Cell Broadcast Service

Acronym (if any): CBS

References for WI " Cell Broadcast Service "

Document	Title/Contents
TP-000022	WI Sheet
Impacted Specifications	
TS 23.041	Technical realisation of Cell Broadcast Service (CBS)
New Dedicated Specifications	
	None

This work item includes the technical realisation of the Cell Broadcast Service. CBS has been made applicable to 3G networks.

41 Support of Localized Service Area

Acronym (if any): SoLSA

References for WI " Support of Localized Service Area "

Document	Title/Contents
WI	Roll-over WI from R98 (02.43)
02.43 v 8.0.0	Support of Localised Service Area (SoLSA); Service description; Stage 1

This feature consisted of a mechanism, which can be used as a platform for providing special tariffs and/or special set of service features for certain subscribers within a regionally restricted area or areas.

The motivation for this concept is to create means for network operators to build new service and tariff packages, which take into account subscriber groups and their needs.

The localised service area is both an optional network feature and an optional UE feature. Usage and implementation of the different SoLSA service features may vary according to operator's service packages.

This feature is not intended to replace the existing method of cell selection, cell indication and handover. "Support of Localised service area (SoLSA)" is renamed Phase 2+ item "Support of Home Area Priority"

There were no additional features for R99.

42 Automatic Establishment of Roaming Relations

Acronym (if any): no acronym

References for WI " Automatic Establishment of Roaming Relations "

Document	Title/Contents
22.71 v 3.1.0	Automatic Establishment of Roaming Relations
22.971 v 3.1.1	Automatic Establishment of Roaming Relations
22.01	UMTS Service Principles
22.101	Service aspects; Service principles

Like GSM the goal of UMTS is a multitude of mobile networks which can interwork. One of the problems of this is that the mechanisms used to setup and manage the interworking arrangements cannot handle this interworking in a cost-effective manner.

Prior to this WI, when two GSM networks wished to interwork, a roaming agreement was set up that was based on the standard GSM MoU agreement. This involved opening a signalling connection for C7 MAP messages between the networks, and a commercial settlement procedure to exchange billing records and net charges within set timeframes.

A standard set of tests has been written by MoU committees SERG and TADIG to checked the functions of basic operation and billing record formats.

Typically this procedure takes 2-4 weeks to setup, test and put online. Additional technical problems for some networks include:

- access to a C7 SCCP signalling link - where these are unavailable, X.25 links have been used;
- conversion between ANSI SS7 and ITU-T C7 message formats - a conversion box is required for these links;
- handling billing records in many different currencies and formats - a small number of clearing houses are able to process and pass on billing records between networks, settling net charges in one currency.

This new feature consisted of a framework for commercial and technical interworking between UMTS Home Environments and Serving Networks who have no direct prior commercial agreements with each other.

The report in 22.71 was applicable to UMTS standardisation within ETSI, and was produced with the intent to clarify the concepts involved, and identify those areas which require standardisation.

In particular:

- Each of the roles in the role model (see 22.01) must be able to setup a commercial agreement with any other party and obtain chargeable services up to the limit of his credit. This includes not only relationships between different roles such as user and home environment, but also between role peers such as between different serving network. Such agreements should be capable of being setup online, between parties which have not interworked before.
- There must not be any substantial overhead for any role to commercially interwork with any new role.
- There must be real-time credit control for the net charges incurred by any role.
- There must be good security to allow each role to authenticate each other prior to incurring charges.
 - Serving Networks and Home Environments shall have the capability to block or veto particular roaming agreements.

The work in R99 was based on TS 22.71 and some semantic changes to the wording were made; e.g. changing Service Provider to Home Environment. In the event, the report concluded that no special standardisation work was required to facilitate Automatic Establishment of Roaming Relationships because these can be implemented with current standards and procedures as discussed in this report.

43 Advanced addressing

[ONLY REQUIREMENTS LISTED HERE. STAGES 2 AND 3 ASPECTS STILL NEED TO BE CHECKED]

Acronym: no acronym

References for WI " Advanced addressing "

Document	Title/Contents
S1-99136	WI Sheet "Advanced Addressing" [TSGS1#2(99)]
22.75U v 3.0.0	Advanced Addressing
22.975 v 3.1.0	Advanced Addressing
CR 22.101-A019	UMTS Advanced Addressing (Approved at SP 04)

This feature consisted of the UMTS advanced addressing scheme requirements for numbering and addressing for UMTS, and example directory, application and translation mechanisms which could be used to enhance the service to the customer.

The work in R99 was based on the R98 TS 22.75U v 3.0.0. The only value added information was the deletion of the term International Mobile User Identifier (IMUI) and the change from International Mobile Station Identifier to International Mobile Subscriber Identidy.

A key requirement was the need for UMTS users to be able to interwork with users on legacy schemes. These would encompass telephony, data and multimedia.

The focus of work was the elaboration of the following requirements for UMTS numbering schemes, addressing schemes, and identification schemes:

- To be able to initiate communications with another party using a label to identify that party. This might be a logical label referring to a job function, and advertising response line etc. and would be resolved into a real terminal address by the UMTS system transparently to the user. Labels shall be capable of being stored in an address book which shall be accessible from any terminal that the user is registered on.
- To have requirements with regard to addressing for receipt of communications. The user shall be able to have a number of different persona (e.g. business and personal), each of which can be managed independently.
- When receiving communications, to be able to perceive the caller's label in the appropriate role. For example, when making a call as chairman of an ETSI committee, then that persona will be presented as the caller ID. When making a personal call, then the underlying persona would be presented.
- To be fully independent of the supporting serving network and the home environment, allowing users to transfer this label to another home environment.
- Serving networks need to be able to communicate with, authenticate and commercially deal with the home environment associated with any USIM being registered on their network. This shall require a USIM identity scheme which uniquely identifies each USIM, and a mapping scheme which allows the USIM identity to be used as a identifier with the "owning" home environment.
- Serving networks also require to be able to route efficiently any communication to and from USIMs (or rather the devices on which they are registered). An address scheme is therefore required for operators to access and map any outgoing or incoming communication to USIMs and thus devices on their networks.
- Operators will also require mapping functions at locations where interworking with legacy networks is provided.
- The home environment shall be able to Resolve the ownership of any USIM to his own, or another environment.
- The home environment shall be able to map a range of labels to any of his USIM. This shall include one or more labels of the same type, and one or more labels of different types.
- Name labels shall allow extended character sets.
- Labels may be used to identify groups as well as individual terminals or people.
- Support E.164 Number Portability, either directly or indirectly, in accommodation with fixed network number portability schemes is required.
- The UMTS system shall allow a end to end transparent application addressing of a large variety of different applications and services on a terminal.
- 3rd party services should be reached by a label. Based on the selected charging policy for this services the calling party or/and the home environment of the calling party needs to be uniquely identified.
- The possibility to address a terminal (rather than a subscriber) may be required for some applications and shall be supported.

- Although a called party may be addressable via different means, he should be reachable independent of the medium. This would require a new functionality which can map name (alpha numeric string) / number (digits) for call routing purposes. Networks might only support basic functionality while advanced databases might be offered by 3rd parties.
- Sequential label translation shall be supported.
- In order to permit interworking with legacy networks, address interworking with common legacy network addressing shall be supported. In principle, this shall include interworking with any networking addressing scheme, but the following schemes listed below shall specifically be supported:
 - E.164,
 - E.168,
 - E.212,
 - X.121
 - ASEA
 - Internet

The work in R99 was based on the R98 TS 22.75U v 3.0.0. The only value added information was the deletion of the term International Mobile User Identifier (IMUI) and the change from International Mobile Station Identifier to International Mobile Subscriber Identity.

44 QoS for Speech and Multimedia Codec

Acronym: QOS-SPEMC

References for WI "QoS for Speech and Multimedia Codec"	
Document	Title/Contents
SA4_Work_Items_History	WI Sheet
SP-99060	WID WI S4-3: QoS for Speech and Multimedia Codec
Impacted Specifications	
TR 26.912	QoS for Speech and Multimedia Codec; Quantitative performance evaluation of H.324 Annex C over 3G
New Dedicated Specifications	
	None

The scope of the feature “QoS for speech and multimedia codec” is to define the requirements on quality, bit rates, Bit Error Rates, Frame Erasure Rate, Delay etc for speech and multimedia services.

Successful provision of speech and multimedia services in UMTS requires knowledge of the requirements that intended applications and codecs set for the PLMN network (bearers, network architecture, etc.) must fulfil. The aim was to produce Technical Reports discussing the end-to-end QoS requirement issues and proposed solutions to provide adequate quality of service (QoS) for circuit switched and packet switched multimedia services within third generation mobile networks, and a Technical Specification for transmission planning aspects of speech (and multimedia) services on third generation mobile network.

Changes to developing 3GPP specifications were felt possible depending upon the output of the study. In particular, the Evaluation of requirements on quality, bitrates, bit error rates, frame erasure rate, delay etc. for speech and multimedia services were felt of relevance.

The output of the work item could be utilised by other 3GPP groups as guidance for setting requirements for satisfactory user-to-user service.

The technical requirements of speech and multimedia codecs found out in Technical Reports of this Work Item should be satisfied by the related QoS parameters and other system implications, and by the speech and/or multimedia codec implementations in mobile terminals. The scope includes speech and multimedia services both in circuit switched and packet switched environments.

The TS on Transmission planning aspects was not completed by SA4 for Release 99.

45 UMTS Numbering, Addressing and Identities

[ONLY REQUIREMENTS LISTED HERE. STAGES 2 AND 3 ASPECTS STILL NEED TO BE CHECKED]

Acronym: no acronym

References for WI " UMTS Numbering, Addressing and Identities "

Document	Title/Contents
CR 22.101-A019r1	UMTS Advanced Addressing (Approved in SP-04 SP-99225)
CR 22.101-A020	Numbering (Approved in SP-04 SP-99229)
CR 22.101-A021	Numbering Scheme (Approved in SP-04 SP-99229)

Work was done on this WI in R99 in SA resulting in a CRs to 22.101. The output from the work on the advanced addressing report 22.75 v 3.0.1 was included in the numbering section of 22.01 (19r1). Also new requirements for Single and Multiple Numbering scheme was added (CR 20 and 21).

46 CC improvements

This are minor improvements to 24.007 and to 24.008 with the intention to increase the number of simultaneous calls/sessions from the present 7, the TI value is increased (NP-99441).

47 L3 Segmentation

There are no CRs for R99, and the CN Plenary agreed to shift L3 segmentation to R2000 where it was later deleted as workitem.

48 Separation of Radio Resource and Mobility Management specific parts of the Mobile Station Classmark

3GPP TR 23.814 (Separating RR and MM specific parts of the MS Classmark) was approved in TSG_NP#6 with related CRs in NP-99447. Clear separation of radio access network technology and core network technology was one prime requirement of UMTS, but also improvement of signalling efficiency. This concept enabled the system to be developed independently from other sub-system technologies.

49 Idle mode classmark

These are minor improvements. CN Plenary #6 agreed in principle to the split of 03.22 and approved the 3GPP TS 23.122 v0.0.0 to become v3.0.0. NP-99455 contained the proposed TS 23.122 NAS Functions related to Mobile Station (MS) in idle mode (03.22 & 23.022 split). The contents of the proposed TS were copied over from 03.22 V 8.2.0, which was used as the template for the split. The intention was that no functional changes should result from the split, and the only modifications to the meaning of the text are cases where there has been a clear contradiction or redundant/incorrect text has existed in the specification. The principle has been that common CN related issues like PLMN selection and location registration procedures have been defined in 23.122, applicable to GSM and UMTS. GSM related cell selection issues are covered in 03.22, and 23.022 became redundant.

50 Feasibility Studies

50.1 CAMEL control of VOIP services - Feasibility Study

50.2 Gateway Location Register (GLR) - Feasibility Study

50.3 Study on Combined GSM and Mobile IP Mobility Handling in UMTS IP CN

One TR at SA2

50.4 Study on provision of facsimile services in GSM and UMTS

50.5 Turbo-Charger: Feasibility Study

NP-99457 contains the TR 23.913 V 1.0.0 on Turbo-charger presented to CN plenary for information and discussion only, since N1 did not agree to include the Turbo-charger for Release 99. It was later also deleted from Release 2000 as a workitem.

Part 6 - Features removed from Rel99

51 Features removed from Rel99

51.1 Connecting an octet stream to a port on an Internet host

CN3 did some work on that. [See IHOSS or OSP sections in 29.061]. In the meantime again removed. It was part of the WI on Modem and ISDN interworking for GPRS that was deleted later on.

51.2 Unstructured octet stream GPRS PDP Type

Same comment as for “Connecting an octet stream to a port on an Internet host”.

51.3 GPRS - Point-To-Multipoint Services

It refers to the CN3 part of an overall function which was already cancelled in SA2.

51.4 Modem and ISDN interworking for GPRS

It was deleted by SA#6 due to lack of requirements - old SMG 4 WI.

51.5 Real time Fax

Moved to Rel 4.

51.6 High Speed Circuit Switched Data

The R99 requirements are a direct lift from 02.57. There were no additional features for R99.

51.7 Provision of text telephony service in GSM and UMTS

Renamed to “Global Text Telephony”, which is a Release Independent Feature completed in Release 5 time frame.

51.8 Support for real time services in the Packet domain for GSM/GPRS/UMTS R99

In Release 5.

51.9 UMTS Core based on ATM Transport

Not done.

51.10 IP-in-IP tunneling in GPRS backbone for UMTS, phase 1

Not done.

51.11 LAPDm performance enhancement

?

51.12 Tandem free operation (TFO) in 3G systems and between 2G and 3G systems

It was moved to Rel-4 at the SA plenary in December 99

51.13 Network Assisted Cell Change

It was moved to Rel-4.

51.14 Interworking with Mobile Satellite Systems

Not done.

51.15 MS Antenna Test Method

Not done.

51.16 Tandem Free Operation (TFO) of speech codecs in Mobile-to-Mobile Calls (MMCs) (GSM 10.53)

Also called "Tandem free operation (TFO) in 3G systems and between 2G and 3G systems"

It was moved to Rel4.

51.17 Out-of-Band Transcoder Control

It was moved to Rel4.

51.18 MS Protocol/RF/EMC conformance specification

Still on-going.

51.19 The CTS (Cordless Telephony System)

Work Item was mostly developed in 1999 (R98).

51.20 SoLSA (Support of Localised Service Area)

Work Item was developed in 1998 as SoLSA is part of release 1998. Note that for some service features CAMEL support will be in release '99.

51.21 Harmonised standard under R&TTE directive

GSM 13.21 (Harmonised standard under R&TTED)

Tdoc SMG2 1449/99 Proposed work item description sheet

Last Part – Unsolved yet

52 Unsolved yet

52.1 MS and Network-Resident Execution Environments (MS/N-RExE)

52.2 Call Forwarding Enhancements (CFE)

(OWNED BY CN4)

seems to be a R99 Work item

SS Ad Hoc

52.3 Unstructured Supplementary Service Data (USSD) enhancements

(OWNED BY CN4)

SS Ad Hoc [SMG 511/96]

TS 04.90 / 24.090

52.4 Access to ISPs and Intranets in GPRS Phase 2 – Separation of GPRS Bearer Establishment and ISP Service Environment Setup

52.5 Generic signalling mechanism for service support

No info

52.6 Impact of Telecommunications Data Protection Directive on GSM Standards

SMG01

52.7 Service to GSM Handportables in trains

SMG02

53 Still to be written (by MCC SA3 support)

53.1 Fraud Information Gathering Service (FIGS)

53.2 Immediate Service Termination (IST)

53.3 Fraud Information Gathering System applied to GPRS

53.4 Immediate Service Termination (IST) : CAMEL free solution

53.5 Lawful Interception (LI)

53.6 SS7 Security - Integrity checking

54 Still to be written (by MCC T3 support)

54.1 Display of Service Provider (SP) name by the Mobile Equipment (ME)

54.2 GSM-API for SIM-Toolkit

54.3 SIM toolkit test specification

54.4 Specification of a bearer independent protocol for SAT applications to exchange data over the GSM network

54.5 Generic Logical and Physical specification for IC card and terminal interface

54.6 Specification of administrative commands and functions for IC cards

54.7 WAP WAE User Agent / SIM toolkit interworking